

UNIVERSIDAD DISTRITAL
FRANCISCO JOSÉ DE CALDAS**VISIÓN ELECTRÓNICA**

Algo más que un estado sólido

<https://doi.org/10.14483/issn.2248-4728>**VISIÓN ELECTRÓNICA****A CASE-STUDY VISION****Collaborative Pick and Place using industrial robots, simulation and deployment***Simulación e implementación de proceso de Pick and Place colaborativo con dos robots industriales***Camilo Alberto Pinzón-Quintero¹, Ángel Andrés Joya-Quintero²,
Felipe González-Roldán³, Pedro Fabián Cárdenas-Herrera⁴****PRELIMINARY PUBLICATION**

This article fulfilled the editorial phases of sending, receiving and accepting for publication in Special edition, Volume 2 Number 1 of the Revista Visión Electrónica, algo más que un estado sólido of the Universidad Distrital Francisco José de Caldas' Technological Faculty. The version evidences the modifications made by the authors from the concepts emanated from the evaluators. Consequently, the preliminary version of the article is visible for consultation and citation; however, it should be clarified that this document is provisional since it has not completed the stages of style correction, translation, layout, as well as details of form corresponding to the completion of the editorial process of the article. This version can be consulted, downloaded and cited as indicated below. Please note that the final document in PDF format -or its metadata- may be different.

PUBLICACIÓN PRELIMINAR

Este artículo cumplió con las fases editoriales de envío, recepción y aceptación para su publicación en la Edición Especial, Volumen 2, Número 1 de la Revista Visión Electrónica, algo más que un estado sólido de la Facultad Tecnológica de la Universidad Distrital Francisco José de Caldas. La versión evidencia las modificaciones realizadas por los autores a partir de los conceptos emanados de los evaluadores. En consecuencia, la versión preliminar del artículo es visible para consulta y cita; sin embargo, debe aclararse que este documento es provisional ya que no ha completado las etapas de corrección de estilo, traducción, diseño, así como detalles de forma correspondientes a la finalización del proceso editorial del artículo. Esta versión se puede consultar, descargar y citar como se indica a continuación. Tenga en cuenta que el documento final en formato PDF, o sus metadatos, puede ser diferente.

¹ BSc. in Mechatronic Engineering, Universidad Nacional de Colombia, Colombia. E-mail: capinzonq@unal.edu.co ORCID: <https://orcid.org/0000-0001-5468-7563>

² BSc. in Mechatronic Engineering, Universidad Nacional de Colombia, Colombia. E-mail: ajoyaq@unal.edu.co ORCID: <https://orcid.org/0000-0001-8395-1415>

³ BSc. in Mechatronic Engineering, MSc. in Industrial Automation, Universidad Nacional de Colombia, Colombia. E-mail: fegonzalezro@unal.edu.co

⁴ BSc. in Electronic Engineering, Specialist in Industrial Automation, Universidad Pedagógica y Tecnológica de Colombia, Colombia. MSc. in Industrial Automation, Universidad Nacional de Colombia, Colombia. MSc. in Automation and Robotics, Universidad Politécnica de Madrid, Spain. Current position: professor at Universidad Nacional de Colombia, Colombia. E-mail: pfcardenash@unal.edu.co ORCID: <https://orcid.org/0000-0002-5014-7268>

Abstract

In recent times, a fraction of industrial robotics has been oriented to a collaborative approach between different devices to achieve a specific task. This paper describes the simulation and deployment of a metallic beam pick a place process using tow industrial robots. At first, the tool design is presented; it used an electromagnet attached to the robot end effector to lift the load correctly. The communication sequence between the robot's controllers using the digital I/O modules is discussed. The software Robot Studio allowed the process simulation, in which the performance was validated. All the tasks were tested in two ABB IRB 140 industrial robots.

Keywords: end-effector design, industrial communications, industrial manipulator, robot programming, synchronized trajectories.

Resumen

En los últimos años la robótica industrial se ha orientado hacia la coordinación entre diferentes manipuladores para realizar una determinada labor. En este sentido, el presente documento expone la simulación e implementación de un proceso Pick and Place de una viga metálica haciendo uso de dos robots industriales. Para tal fin, se diseñó una herramienta de electroimán para levantar apropiadamente la carga. Además, se elaboró una secuencia de comunicación entre los dos robots haciendo uso de los módulos de I/O digitales de los controladores, para así sincronizar el movimiento de los robots de manera sencilla. Finalmente, se implementó el proceso y se verificó el funcionamiento correcto de todos los sistemas descritos anteriormente.

Palabras clave: diseño de efector final, comunicaciones industriales, manipulador industrial, programación de robots, trayectorias sincronizadas.

1. Introduction

Industrial robots have played a vital role in the development of automated factories over the past 50 years. The growth of robotic manipulators related to industrial applications has been

exponential, since 1961, when Unimation was installed at the General Motors assembly plant in Detroit. According to the IRF [1], in 2017, more than 2 million robots had been installed over the world. The number of industrial robots has allowed diversification of its uses; at the beginning, the main applications were welding, assembly, painting, and machining. Even though nowadays, it is common to find robots in such complex scenarios, like medical procedures and collaborative work cells with human workers [2].

The process of move an object from a first work station to a second work station, being both stations located in the robot's workspace, is commonly known as pick and place (P&P) [3]. It is worthy of mentioning that a P&P process implies a pose change, which means a position and orientation modification. In some industrial applications to solve the handling of heavy pieces, two approaches are employed. The first one consists of the use of high load manipulators, and secondly, the incorporation of multiple robots that executes tasks in a coordinated way.

The utilization of heavy-duty robots is the most common way to solve the handling of heavy pieces. Nevertheless, in recent times multiple industrial robot manufacturers have developed tools that allow the use of one or more robots in a collaborative way. Some recognized applications are Multimove by ABB [4] or RoboTeam by Kuka [5]. These tools enable the synchronized movement of multiple robots so that they can share a common reference frame; therefore, they can work on the same piece. It is relevant mentioning the main difference among coordinated and synchronized movement; the first one has to do with the reference system that a set of robots use for the task execution process [6]; while in the case of the second one, the movement of the robot is done at the same time [6].

Specialized applications such as Multimove and Roboteam requires specific hardware and software modules, which implies additional expenses in comparison to the cost of a traditional robotic solution. Colombian industry still is at an early stage regarding automated and robotic stations [7]. Therefore, companies interested in robotics need technological solutions at the

lowest cost possible. Also, robotic systems should be as flexible as possible; so, they can be used in different tasks in a factory. In this way, a couple of robots that performed separated roles in a production line can be employed in a cooperative task, such as the handling of a massive piece without purchasing new equipment. The processing of a rigid and heavy material, such a metallic beam implies an additional overload on the robot's actuators [8]; to prevent a premature failure on the robot, the load distribution among multiple robots is considered a feasible solution [9].

This paper aims to run a collaborative P&P process of a metallic beam using two industrial robots ABB IRB 140 located in the LabSIR (Laboratorio de Sistemas Inteligentes Robotizados) at the Universidad Nacional de Colombia. The process was implemented using the controllers I/O modules for each robot. Also, a specific work sequence was created to allow the synchronization of the robot's trajectories, without damages in the moving piece nor the robot's mechanisms.

This document is organized into three sections. At first, an introduction of automated and robotic solutions is stated, it is emphasized the need for collaborative tasks in the modern industry, especially in the Colombian context. In the second part, the methods used to accomplish the collaborative P&P are described, starting with the end effector design, followed by the simulation process done in Robot Studio and finishing with the deployment in the actual robots. The third section discusses the results obtained, and then the conclusions and future work are mentioned.

2. Methods

A set of steps was proposed to accomplish the simultaneous collaborative P&P using two industrial robots. Firstly, the tool design was performed; its calibration was made through two different methods to ensure its functionality as an end effector. Subsequently, the robot's motion

and communication routines were programmed in Robot Studio, which allowed a complete simulation of the process. As the final step, the simulation results were deployed and tested on the real industrial manipulators.

2.1. Tool design

2.1.1. Mechanical design and components selection

The main design parameters for the tool were the tool material and the piece weight. The selection process was accomplished by using a specialized catalog; finally, an electromagnet that met all the requirements was chosen, the component has the following technical specifications:

- Brand: Security Home.
- Power supply: 12-14 VDC
- Load capacity: 180 lbf (max).
- Dimensions: 72x31x27 mm.

An L shape plate was designed to couple the electromagnet to the robot's endpoint. The longest part of the plate is used to connect the robot's flange to the tool through M6 screws [10]; in the shortest side of the plate, the electromagnet is located, which is attached via a couple of M5 screws. In Figure 1 is presented the machine tool design.

Figure 1. Machine tool design intended for metallic pieces gripping.

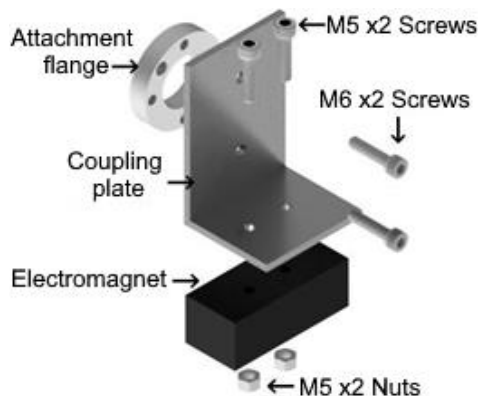

Source: own.

The P&P requires two processes related to the piece, attachment, and release; the first one was solved by using the electromagnet and the proposed tool as well, the second process demanded an additional component called antiremanent module, whose function is to demagnetize the tool, this effect was reached in an average time of 0.5 s.

2.1.2. Tool calibration

With the tool assembled and mounted in the manipulator, the calibration process was carried out. Two approaches may be used: through software or using a physical procedure. The first one requires the software Robot Studio, in which the CAD model of the tool is imported for its virtual calibration (Figure 2). Two coordinate frames are created, one located on the tool base and another on the TCP (Tool Central Point). Then both structures are linked through a transformation matrix, which is calculated by the data provided. The physical approach requires that the tool was mounted at the robot flange; the Teach Pendant offers a series of options to calibrate the robot tool. According to the electromagnet geometry, the most suitable one was the mode with 3 points and one axis; therefore, that method was selected. The electromagnet center is located at the same position with three different orientations. Next, using a vertical axis that crossed the fixed point, the tool approach axis is aligned with it, and an approximation process is made to the fixed point. The robot controller automatically computes a transformation matrix that represents the tool.

Figure 2. Virtualized tool calibrated in Robot Studio.

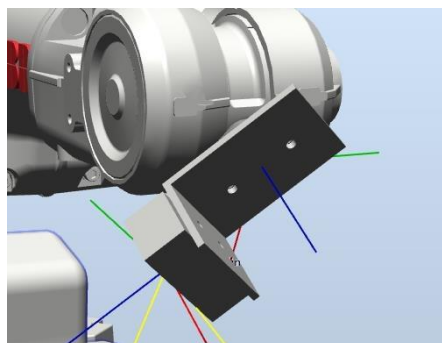

Source: own.

Table 1 shows information related to the tool calibration process. The position data in both procedures is relatively comparable. On the other hand, orientation results show a considerable difference, since the virtual process is no susceptible to human error, the data provided from this method was chosen. The most likely reason for the orientation difference has to do with the axis aligning process in the physical approach, which is human vision guided, hence highly subject of error.

Table 1. Comparison of the tool data calibration results. Position (X, Y, Z) expressed in (mm); orientation expressed in quaternions (Q1, Q2, Q3, Q4).

Calibration	X	Y	Z	Q1	Q2	Q3	Q4
Physical	-46.9	55.3	26	0.65	-0.27	-0.65	-0.27
Virtual	-42.6	54.63	25.1	0.36	-0.92	-0.05	0.12

Source: own.

2.2. Robot programming and simulation in Robot Studio

The robot's programming and simulation started by locating two ABB IRB 140 manipulators in the software Robot Studio, according to the layout in the LabSIR. An additional extruded prism was located to emulate the beam with which the process was going to be done.

A set of specialized coordinate systems called workobjects were located at the same point in the beam for each robot. The primary purpose of the workobjects is to guide the targets that control the robot's trajectories. It is worth mentioning that workobjects are easily changeable. If they are modified, all data associated with them is modified as well, so much work can be saved when path changes are required.

With the proper references specified, the robot's trajectories were created. In Robot Studio, the waypoints that each robot had to pass through were defined. Then those points were linked by a specific type of motion. Table 2 shows the required motion parameters for the ABB industrial robots.

Table 2. Motion parameters required to program an ABB industrial robot.

Motion parameter	Description
Motion type	The robot's end effector can be moved on a linear path (MoveL), circular path (MoveC), or free motion in the task space (MoveJ).
Tool speed	Represents the robot's end effector speed measured in mm/s.
Zone tolerance	Indicates the tolerance of the robot's end effector when passing through a target. It is expressed in mm.

Source: adapted from [4].

The motion sequences programmed for each robot are described as following:

- Approaching to the beam: MoveJ, speed v200, zone fine (the TCP passes precisely through the target).
- Beam lifting: MoveL, speed v600, zone z10 (the TCP passes to a max. distance of 100mm to the target).
- Beam translation: MoveL, speed v1000, zone z10.
- Beam orientation change: MoveL, speed v600, zone 10. This motion rotates the beam 90° without translation.
- Beam dropping: MoveL, speed v600, zone fine.
- Return to home: MoveJ, speed v200, zone fine.

Figure 3. Programmed trajectories for each robot.

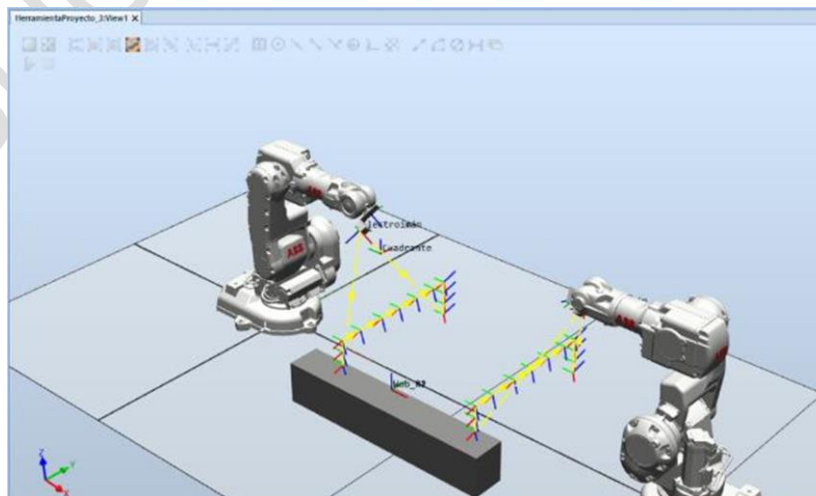

Source: own.

In general, the communication sequence consisted of each robot enabling a digital flag when the initial pose was reached. At the same time, each robot waited until the other robot arrived at the initial pose, and then start the motion. Figure 4 shows the graphical representation of the communication sequence. Although the two robots arrive at different times to the initial pose, each one waits to receive the other robot signal to start the process.

With each robot motion routine programmed, a simulation in Robot Studio allowed a validation procedure. Targets and motion parameters were adjusted in the same way for both robots; the simulation showed that the entire process was continuous, and it lasted approx. 12 s.

Figure 4. Communication sequence between industrial robots used in this application.

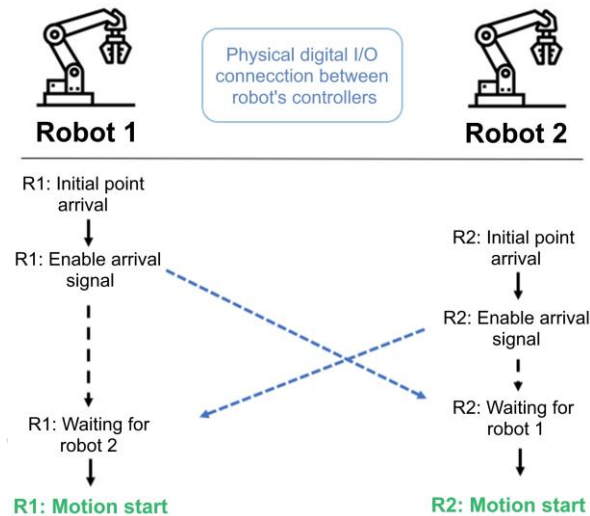

Source: own.

2.3. Deployment in industrial robots

After the simulation validated the results, the motion routines were implemented in the industrial robots ABB IRB 140. In section 2.1 was mentioned that the robot's tool used an antiremanent module to control its magnetization; this component has an integrated buzzer to indicate when it is enabled. The antiremanent module had a push-button as an original control method. A relay replaced this button, which can be activated from the robot controller using digital output; in this way, the magnetization process was controlled straightly by the robot.

Figure 5. Tool connections diagram.

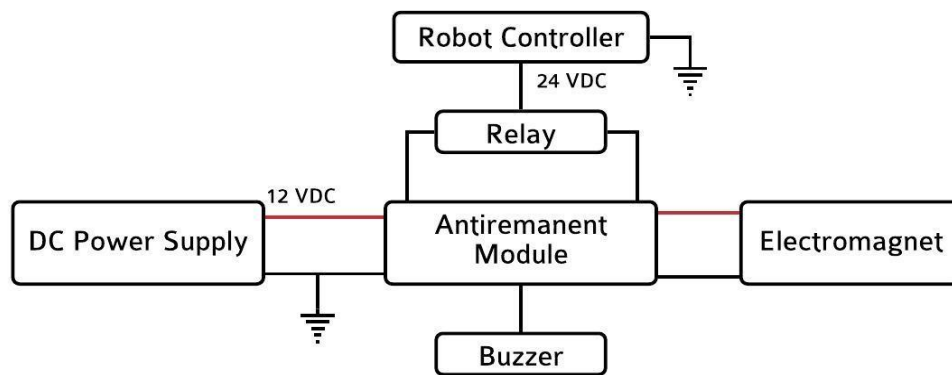

Source: own.

With the connections diagram done (Figure 5), the I/O pins on each IRC5 controller were assigned. Tables 3 and 4 present the pins assignation and the corresponding functions.

Table 3. Input/output assignation for robot controller number 1.

Pin	Type	Function
1	Output	Communication with robot number 2
8	Output	Electromagnet disable
10	Input	Process start
16	Input	Waiting for robot number 2

Source: own.

Table 4. Input/output assignation for robot controller number 2.

Pin	Type	Function
1	Output	Robot motion indicator
3	Output	Electromagnet enable
5	Output	Communication with robot number 1
8	Output	Robot availability indicator
10	Input	Waiting for robot number 1
16	Input	Process start

Source: own.

3. Results

The total time for the test using the real robots was 12.15 s. The approach motion lasted 4.24 s, 1.14 s for the communication sequence, 2.19 s of robot motion, and 3.15 s for the trajectory to the initial pose. The simulation time in Robot Studio was 12 s; therefore, the difference is barely existent. (See Figure 6)

Figure 6. Real implementation using two ABB industrial robots.



Source: own.

It is worth mentioning that by using the digital input/output module in the robot's controller, the motion synchronization between the two robots was satisfactory. Although the robots arrived at different times, the defined communication sequence allowed the simultaneous movement. A tiny time gap was present due to time that the robots use to send and receive the digital signals; nevertheless, this time did not affect the process execution. As a result, no delay in the motion was observed, nor the piece suffered any damage.

4. Conclusions and discussion

By utilizing the digital input/output modules, included in most of the industrial robot's controllers, the implementation of a collaborative P&P task was possible. Processes that require

synchronous motion can be done with ease, using basic communication sequences between multiple manipulators.

The previous idea served as the base to a real task, in which two robots handled a metallic beam. Usually, this task would have been required either a bigger robot or the use of specialized software.

A small-time difference was observed by comparing the times obtained in both the simulation and the real test. This time gap is the result of the procedures executed inside the robot's controller; nevertheless, it did not affect the actual task in any sense.

According to the obtained results, a comparison between the implemented solution and a task using the ABB Multimove option would be useful to identify the limitations of the approach developed in an industrial context. Also, the use of different communication protocols between robots is proposed to determine if better motion synchronization can be achieved.

Acknowledgments

Special thanks to the Universidad Nacional department of mechanical and mechatronic engineering, to the Laboratorio de Sistemas Inteligentes Robotizados (LabSIR) and all its personnel for having helped in the development of the present work. An acknowledgment to Brian Avila for all his contributions aided to finish this paper successfully.

References

- [1] IFR International Federation of Robotics, "Executive Summary World Robotics 2017 Industrial Robots", pp. 23–24, 2017. [Online]. Available at: https://ifr.org/downloads/press/Executive_Summary_WR_2017_Industrial_Robots.pdf
- [2] B. Siciliano, and O. Khatib, "Springer Handbook of Robotics", Springer, 2007. <https://doi.org/10.1007/978-3-319-32552-1>
- [3] C. V. Doan, "Pick and Place Machine", U.S. Patent 5564888A, September 27 1993.
- [4] ABB, "IRC5 Industrial Robot Controller". [Online]. Available at : <https://new.abb.com/products/robotics/controllers/irc5>

- [5] KUKA, “KUKA.RoboTeam”. [Online]. Available at: https://www.kuka.com/es-es/productos-servicios/sistemas-de-robot/software/tecnolog%C3%ADas-transversales/kuka_roboteam
- [6] A. Blomdell, I. Dressler, K. Nilsson, and A. Robertsson, “Flexible Application Development and High-performance Motion Control Based on External Sensing and Reconfiguration of ABB Industrial Robot Controllers”, in IEEE Int. Conf. Robot. Autom., pp. 62–66, 2010.
- [7] J. E. Pinzón-Varela, “Diseño de un sistema robotizado que permita paletizar el embalaje de jugos en presentación de cajas tetra pack de 200ML, en la empresa de Productos Alimenticios Alpina Cauca”, thesis, Universidad Autónoma de Occidente, Colombia, 2017.
- [8] I. B. Chelpanov, and S. N. Kolpashnikov, “Problems with the mechanics of industrial robot grippers”, *Mech. Mach. Theory*, vol. 18, no. 4, pp. 295–299, 1983. [https://doi.org/10.1016/0094-114X\(83\)90122-2](https://doi.org/10.1016/0094-114X(83)90122-2)
- [9] K. Tai, A.-R. El-Sayed, M. Shahriari, M. Biglarbegian, and S. Mahmud, “State of the Art Robotic Grippers and Applications”, *Robotics*, vol. 5, no. 2, p. 11, jun. 2016. <https://doi.org/10.3390/robotics5020011>
- [10] ABB, “Product specification Articulated robot IRB 140”, p. 19, 2004. [Online]. Available at: https://library.e.abb.com/public/603383cd889d40598d1d2bf993e0f503/3HAC9041-1_rev6_en_library.pdf