

Dakota State University  
**Beadle Scholar**

---

Faculty Research & Publications

College of Business and Information Systems

---

6-2020

## Mining User-generated Content of Mobile Patient Portal: Dimensions of User Experience

Mohammad al-Ramahi  
*Texas A&M - San Antonio*

Cherie Noteboom  
*Dakota State University*

Follow this and additional works at: <https://scholar.dsu.edu/bispapers>



Part of the [Databases and Information Systems Commons](#), [Data Science Commons](#), [Data Storage Systems Commons](#), and the [Health Information Technology Commons](#)

---

### Recommended Citation

Mohammad Al-Ramahi and Cherie Noteboom. 2020. Mining User-generated Content of Mobile Patient Portal: Dimensions of User Experience. *ACM Trans. Soc. Comput.* 3, 3, Article 15 (June 2020), 24 pages. <https://doi.org/10.1145/3394831>

This Article is brought to you for free and open access by the College of Business and Information Systems at Beadle Scholar. It has been accepted for inclusion in Faculty Research & Publications by an authorized administrator of Beadle Scholar. For more information, please contact [repository@dsu.edu](mailto:repository@dsu.edu).

# Mining User-generated Content of Mobile Patient Portal: Dimensions of User Experience

MOHAMMAD AL-RAMAHI, College of Business, Texas A&M-San Antonio, San Antonio, TX  
CHERIE NOTEBOOM, College of Business & Information Systems, Dakota State University,  
Madison, SD

Patient portals are positioned as a central component of patient engagement through the potential to change the physician-patient relationship and enable chronic disease self-management. The incorporation of patient portals provides the promise to deliver excellent quality, at optimized costs, while improving the health of the population. This study extends the existing literature by extracting dimensions related to the Mobile Patient Portal Use. We use a topic modeling approach to systematically analyze users' feedback from the actual use of a common mobile patient portal, Epic's MyChart. Comparing results of Latent Dirichlet Allocation analysis with those of human analysis validated the extracted topics. Practically, the results provide insights into adopting mobile patient portals, revealing opportunities for improvement and to enhance the design of current basic portals. Theoretically, the findings inform the social-technical systems and Task-Technology Fit theories in the healthcare field and emphasize important healthcare structural and social aspects. Further, findings inform the humanization of healthcare framework, support the results of existing studies, and introduce new important design dimensions (i.e., aspects) that influence patient satisfaction and adherence to patient portal.

CCS Concepts: • **Information systems** → **Data analytics**; • **Applied computing** → **Health care information systems**; **Consumer health**; **Health informatics**;

Additional Key Words and Phrases: Patient portal, user-generated contents, latent dirichlet allocation (LDA), sentiment analysis, explanatory analysis, predictive analytics

## ACM Reference format:

Mohammad Al-Ramahi and Cherie Noteboom. 2020. Mining User-generated Content of Mobile Patient Portal: Dimensions of User Experience. *ACM Trans. Soc. Comput.* 3, 3, Article 15 (June 2020), 24 pages.

<https://doi.org/10.1145/3394831>

## 1 INTRODUCTION

“The nation's expenditures for health care, already the highest among developed countries, are expected to rise considerably as chronic diseases affect growing numbers of older adults. Today, more than two-thirds of all health care costs are for treating chronic illnesses. Among health care

Author's addresses: M. Al-Ramahi, College of Business, Department of Computing and Cyber Security, Texas A&M-San Antonio, One University Way, San Antonio, TX 78224 (210) 784-2371; emails: mrahman1@tamusa.edu, mohammadarefaramahi@gmail.com; C. Noteboom, College of Business and Information Systems, Dakota State University, 820 N Washington Ave., Madison, SD 57042; email: cherie.noteboom@dsu.edu.

Permission to make digital or hard copies of all or part of this work for personal or classroom use is granted without fee provided that copies are not made or distributed for profit or commercial advantage and that copies bear this notice and the full citation on the first page. Copyrights for components of this work owned by others than ACM must be honored. Abstracting with credit is permitted. To copy otherwise, or republish, to post on servers or to redistribute to lists, requires prior specific permission and/or a fee. Request permissions from [permissions@acm.org](mailto:permissions@acm.org).

© 2020 Association for Computing Machinery.

2469-7818/2020/06-ART15 \$15.00

<https://doi.org/10.1145/3394831>

costs for older Americans, 95% are for chronic diseases. The cost of providing health care for one person aged 65 or older is three to five times higher than the cost for someone younger than 65. By 2030, health care spending will increase by 25%, largely because the population will be older” [1]. The United States spends 17.4% of its GDP on healthcare, more than any other country in the world [2]. Despite this \$2.9 trillion expenditure, the quality and efficiency of the U.S. healthcare system ranks last when compared with Australia, Canada, France, Germany, the Netherlands, New Zealand, Norway, Sweden, Switzerland, and the United Kingdom [3]. To reduce the huge costs in the healthcare sector, a concerted national effort to reform healthcare using information technology (IT) is well underway [2].

In this regard, *patient portals* hold promise for assisting with reducing healthcare cost and improve population health. Patient portals are consumer-centric tools that can strengthen consumers’ ability and behavior to actively manage their own health and healthcare. Patient portals generally capture information about an individual’s diagnoses, medications, allergies, lab-test results, immunization records, and other personal health information. In addition, patient portals provide convenient tools to manage appointment functionality, prescription support, and billing processes, and communication tools that can assist the consumer in connecting to various healthcare professionals [4]. Patient portals encourage patients to play a more active role in their healthcare by giving them more responsibility for maintaining a healthy lifestyle and managing chronic diseases, and thus they may provide a cost-effective way to improve quality of care [5].

Despite their potential benefits and growing popularity, patient portals still have not been used to their fullest potential. Health IT leaders point to a poor user experience as a significant reason for the low rates of use by patients [6]. As shown in previous research on use of the patient portal, patients experience common frustrations, such as difficulties in following up with healthcare providers [7], failures in personal reminder systems [8, 9], and gaps in attitudes between patients and healthcare providers about the use of technology in health management. Sadly, only 29% of patients would give their healthcare providers an “A” for use of technology to engage with them [10]. The bottom line is that 9 in 10 patients would like to be able to access their personal healthcare records more easily [10]. Developing patient portals that offer innovative user experiences is a challenging task. By definition, the concept of innovating with user experience goes beyond developing patient portals that merely satisfy users’ expectations of technology. Instead, portals must provide unexpectedly meaningful and delightful user experiences [11, 12]. The key challenge of integrating portals in patient care is to go beyond pure technology to contexts of daily life of users [13]. Understanding user task goals, user interactions and capturing appropriate context are some of the open issues that remain in supporting the design of patient portal [14]. Leveraging patient portals for self-care, self-management and patient empowerment will require anchoring designs in relevant theories and adopting a holistic socio-technical perspective [14]. The Social-Technical Systems model provides a comprehensive framework that can be applied to better guide the design and implementation of health information technology [15]. Therefore, in this study, we use the Social-Technical Systems theory to inform our findings.

Existing studies, e.g., References [16–18], have mainly relied on survey-based approaches to capture behavioral intent to accept or use the patient portal. With advances in data analytics, newer approaches that track and analyze actual use of systems can provide a much better indicator of system acceptance and use. Therefore, better understanding of the adoption and usage of patient portals requires studies that systematically analyze user feedback gathered from electronic word-of-mouth (eWOM). Advances in Web 2.0 technologies have enabled consumers to easily and freely exchange opinions on products and services on an unprecedented scale (volume) and in real time (velocity). Online user review systems are user-generated content systems that provide one of the most powerful channels for extracting user feedback that can help enhance Health

Information Technology (HIT) design. In the e-commerce domain, user-generated content as social media systems have long been widely recognized as a crucial factor that influences product sales, e.g., Reference [19], and shapes consumer purchase intention, e.g., References [20–22]. In the domain of patient portals, analyzing user-generated content (i.e., online user reviews) has the potential to greatly inform developers about patients’ actual experiences and provide a window into ways to improve care delivery and patient satisfaction.

This study extends our prior works [23–25] and focuses on analyzing and inferring *dimensions relating to the user experience of mobile patient portals* from online user reviews. First, we examine which dimensions (i.e., aspects) are expressed in the textual contents of users’ reviews of patient-portal mobile apps. We use MyChart reviews, as Epic has captured significant market share with at least partial health information for 51% of the U.S. population. It has been described as the default EHR choice, not for its superior performance, but because other systems are considered inferior [26]. Given the huge amounts of mobile app review data available, and to facilitate the analysis process, we utilize a text-mining approach, specifically topic modeling, to automatically analyze the contents of user reviews. Topic modeling technologies and techniques can effectively extract dimensions of user satisfaction from a large corpus of text data. A topic model is a type of probability model for discovering the abstract “topics” that occur in a collection of documents [27]. Although topic mining is traditionally applied to natural language documents, it has also been used to differentiate the topics in technical discussion forums such as Stack Overflow [28, 29] and SourceForge [30, 31]. It has also been applied to large software repositories such as Hadoop or Petstore [32–34]. The Latent Dirichlet Allocation (LDA) algorithm adopted for this study [35] is the most common method for topic modeling. Second, we investigate whether reviewers’ rating of the patient portal can be explained through the dimensions (i.e., aspects) extracted from online reviews. This explanatory analysis is particularly beneficial to patient portal providers in understanding which aspects are influencing consumer satisfaction. Third, the study builds on the results from the previous analysis to explore whether user’ rating of patient portal can be predicted using dimensions mentioned in online reviews. In building the predictive models, dimension-specific sentiments are examined and compared against a typical text-mining approach based on a bag-of-words model. The analysis is useful for both potential users as well as healthcare service providers from a decision support stance. Users can make informed decisions using the predicted rating scores, while service providers can attain performance indicators to better manage the service.

The main contributions of this study are summarized as follows:

- (1) From a theoretical perspective, the results of this research inform the Social-Technical Systems theory and Task-Technology Fit theory as well as contribute to the knowledge base of the nascent literature pertaining to the patient portal. Specifically, the findings foster integrating the patient portal into the health management work ecosystem. Further, the study provides more insights into adopting mobile patient portals. These insights could assist in providing new directions for progression of research in this area. Moreover, since these insights are extracted from user feedback that reflects user preferences, they are likely to influence user acceptance of these technologies. Therefore, the study also contributes to the literature of user acceptance of patient portals and patient satisfaction.
- (2) From a practical and applied research perspective, the study provides developers with insights into the user-reported issues of patient-portal mobile apps and suggestions to influence patient satisfaction. Further, the findings demonstrate the importance of social support design features like support groups to support the aspects of togetherness and agency in patient health care.

Table 1. Design Directives for Self-care Systems [14]

Reference Gap	Design Directives
Task-actor	System should help overcome user deficiencies in performing the self-care task
Task-structure	The system design should accommodate the supporting elements of the external structure in support of the Task and help overcome deficiencies in structural environment with which self-care processes are embedded.
Task-technology	The system design should incorporate use of reliable technology to support all critical components of a self-care task.
Actor-technology	Actors should be provided training on appropriate use of technology when required
Actor-structure	The system design should accommodate the supporting elements of the external structure in support of the Actor
Technology-structure	The system should fit well within the structure in which it is used

The remainder of the article is organized as follows. The next section provides theoretical background, followed by a summary of related work, a description of our research methodology, a presentation of our experimental results, and discussion and implications. The last section concludes the article.

## 2 THEORETICAL BACKGROUND AND RELATED WORK

### 2.1 Social-technical Systems Theory

A socio-technical system can be modeled as a collection of four components, namely, tasks, actors, structure, and technology and their inter-relationships [36, 37]. Tasks describe the goals and purpose of the system and the way work/activities is accomplished. Actors refer to users and stakeholders who perform and influence the work/activities. Structure denotes the surrounding project and institutional arrangements while technology refers to tools and interventions used to perform the work/activities. The socio-technical theory has been used by Lyytinen and Newman [37], where the socio-technical components and their connections are considered the general “lexicon” for describing the information system change.

Socio-technical considerations are also applicable to information systems for self-care, self-management, and patient empowerment such as patient portal [14]. Indeed, the design of self-care computing applications has emerged as a notable research area [38]. However, most research in healthcare systems design is oriented towards technological aspects and is not people focused [14]. The key challenge in self-care systems design is to move the focus from pure technology to contexts of daily life of patients and users [13]. The context or the social system where technology is applied is important when evaluating consumer health applications [39]. In this regards, El-Gayar, Sarnikar and Wahbeh [14] developed design directives for selfcare systems based on the socio-technical theory and provide illustrative examples of how such directives can be implemented for the design of self-care systems (see Table 1).

### 2.2 Task-technology Fit Theory

Task-technology fit (TTF) theory bears that IT is more likely to have a positive impact on individual performance and be utilized if the capabilities of the IT match the tasks that the user must

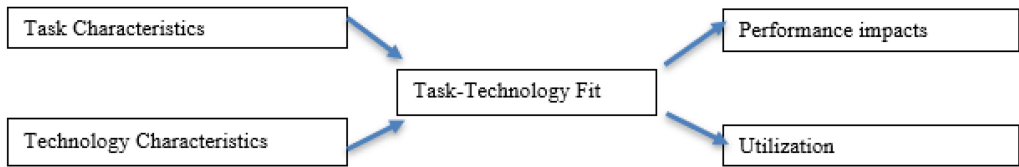

Fig. 1. Task-technology fit theory.

perform, that is, when a technology provides features and support that “fit” the requirements of a task [40] (see Figure 1). According to this theory, information systems have a positive impact on performance only when there is correspondence between their features and the task requirements of users [40].

### 2.3 Patient Health Records (Patient Portal)

Existing research on patient portals has primarily focused on examining their impact on health-service delivery, quality, and patient outcomes, e.g., References [41–44]. Other studies explored the factors (barriers and facilitators) that influence users’ intentions to utilize patient-portal systems, e.g., References [45–47]. For example, Brédart et al. [48] studied a number of characteristics that influence patient satisfaction such as patient-provider communication, technical quality, waiting time, factors related to payments, continuity of provider/location of care, physical environment, and availability of medical care resources. Ahmad et al. [49] studied factors influencing patient satisfaction and concluded that accessibility and availability of medical services influence patient satisfaction. Waters et al. [50] studied factors related to patient satisfaction using a cross-sectional, qualitative design and concluded that waiting/contact time, trust, empathy, communication, expectation, and relatedness influence patient satisfaction.

Table 2 summarizes findings from pertinent studies that have addressed patients’ potential for using portals, and their relationships with other relevant factors including patient-use intention and satisfaction. However, existing studies mainly focused on analyzing data collected from survey or interviews. It seems that the systematic analysis of user feedback gathered from electronic word-of-mouth (eWOM) has been ignored or rarely examined in the previous research.

### 2.4 Mobile Personal Health Records (m-PHRs)/Mobile Patient Portal

With the exponential growth of communications technologies with potential to reach more individuals regardless of their locations, new types of health intervention have emerged. Smartphone or mobile-based health apps can enhance patient engagement at a very low cost. While the results of HIT use by providers are mixed, it appears that motivated patients can achieve significant improvements in their health outcomes when they use mobile applications [52]. Due to the promising influence of these smartphone-based technologies on supporting healthy lifestyle and self-care practices, researchers have been inspired to explore the impact and use of mobile applications (apps) in different healthcare areas, e.g., References [53–59].

Mobile patient portals (M-patient portal) that use a smartphone or tablet device have also been developed to provide more accessibility and mobility for managing patient health. M-patient portal could be the hub of m-health, because it can put patient health information in the hands of patients and be directly connected to peripheral devices such as activity trackers and blood-sugar test devices [60]. Therefore, m-patient portal has the potential to better inform and engage patients in their care. Healthcare providers feel the information provided by a patient portal helps facilitate patient engagement in care and identification of errors [51]. However, little research has been done



Table 2. Pertinent Studies

Article	Methodology	Objective	Findings
<b>Factors (barriers and facilitators) that influence users' intentions to utilize patient-portal systems</b>			
[45]	Behavioral research/survey data	To explore the factors that influence users' intentions to utilize patient portal system using both a questionnaire survey and a log file analysis that represented the real use of the system.	Results indicate the influence of the factor of performance expectancy on the intention to use the patient portal system.
[46]	Survey study/ <i>systematic review</i>	To identify barriers and facilitators of using patient portal.	Barriers included a lack of patient capacity, desire, and awareness of portal/portal functions, patient capacity, lack of provider and patient buy-in to portal benefits, and negative patient experiences using portals. Facilitators of portal enrollment and utilization were providers and family members recommending and engaging in portal use.
[47]	Qualitative study/semi-structured interviews.	To identify barriers to and facilitators of using patient portal.	Five themes identified including limited knowledge, satisfaction with current care, limited computer and internet access, desire to learn more, and value of surrogates.
[51]	Qualitative study/semi-structured interviews.	To assess patients' and healthcare providers' perceptions of a hospital-based portal and identify opportunities for design enhancements.	Optimizing a hospital-based patient portal will require attention to type, timing and format of information provided, as well as the impact on patient-provider communication and workflow.
<b>The impact of patient portal on health-service delivery, quality, and patient outcomes</b>			
[41]	Survey study/ <i>systematic review</i>	To examine how patient portals contribute to health service delivery and patient outcomes.	Patient portals can lead to improvements in clinical outcomes, patient behavior, and experiences.
[42]	Experimental design	To assess whether patient portals influence patients' ability for self-management, improve overall health, and reduce healthcare utilization.	Portals may improve access to providers and health data that lead to improvements in patients' functional status and reduce high-cost healthcare utilization.
[43]	Survey study/ <i>systematic review</i>	To summarize results the effect of patient portals on quality, or chronic-condition outcomes, and its implications to Meaningful Use.	Very few studies associated use of the patient portal, or its features, to improved outcomes. Other studies reported improvements in medication adherence, disease awareness, self-management of disease, decrease of office visits, and increase in quality in terms of patient satisfaction and customer retention.
[44]	Survey study/ <i>systematic review</i>	To address the impact of electronic patient portals on patient care.	Insufficient evidence to support how portals empower patients and improve quality of care. Also, access to information is probably only one facet of patient satisfaction.

to connect the growing use of mobile applications by patients to access their healthcare data. The focus of previous studies includes providing access to the patient record and information on the care team through a mobile phone app [e.g., 61], a tablet computer app to view care-team profiles and hospital medication records, and a tablet app with the plan of care, and diet and safety information [62]. Providing patients real-time access to health information has been demonstrated as a positive force for change in the way care is provided [63]. In this regard, Lu et al. [64] developed an app to inspect controlled substances in patient-care units. Using a web-enabled smartphone, pharmacist inspection can be performed on site, and the inspection results can be directly recorded into the Health Information System (HIS) through the Internet, so that human error in data translation can be minimized, and work efficiency and data processing can be improved.

While previous studies report positive findings, including patient reports of enhanced engagement in the care process and satisfaction with care, none include patient-centered functionality such as the ability to send messages to the care team, or allowing patients to input information or record notes—elements that have been demonstrated to further enhance patient engagement [63]. This is especially true with the proliferation of wearable devices that can collect data about an individual's health state by real-time sampling and analysis of a few parameters, using noninvasive, inexpensive, and portable devices [65]. Neubeck et al. [66] adopted a collaborative user-centered design process to develop a patient-centered e-health tool. O'Leary et al. [51] concluded that optimizing a hospital-based patient portal will require attention to type, timing, and format of information provided, as well as the impact on patient-provider communication and workflow. Patients can identify areas of improvement that could enhance the design of portals. For example, patients suggested including a test-result feature [51]. Therefore, further research is needed to work in concert with patients to explore *patient-centered functionalities* that help develop a patient-centric portal to increase patients' engagement in their care.

Leveraging user feedback from the actual use of a mobile patient portal, this research contributes to an understanding of how the technology architecture can enable patients to interact with patient-portal functionality (technological adaptation) to work (work adaptation) together with their physicians and care providers (social adaptation) using the content available to them, and using collaboration media to provide patient-centered care.

Several researchers in the areas of social media and e-commerce have studied the effects of user-generated content, such as online users' reviews and rating systems, on product sales and consumers' purchase intention. The findings of the existing research demonstrate that analyzing and measuring these electronic word-of-mouth (eWOM) messages is quite valuable in product design, sales prediction, marketing strategy, and other decision-making tasks, e.g., References [19, 27, 67]. However, to our knowledge, no research to date has looked at online user reviews in the context of patient-portal systems. User reviews implicitly communicate satisfaction/dissatisfaction based on actual usage experience and may provide a good opportunity for extracting insights that can strongly influence user satisfaction that informs the design of these systems.

### 3 RESEARCH METHODOLOGY

This section describes the methodology used to systematically analyze the online-user reviews of a mobile patient portal. Figure 2 shows the framework of the text-mining-based method, adopted from Al-Ramahi et al. [68]. First, we collected and prepared the data set. Second, we propose to use an unsupervised topic model, Latent Dirichlet Allocation (LDA), to extract latent dimensions (i.e., hidden topics) from user-generated data. Third, we conducted dimension-specific-sentiment analysis. Then, we performed exploratory and predictive analysis. Below, we will explain each process in the framework.



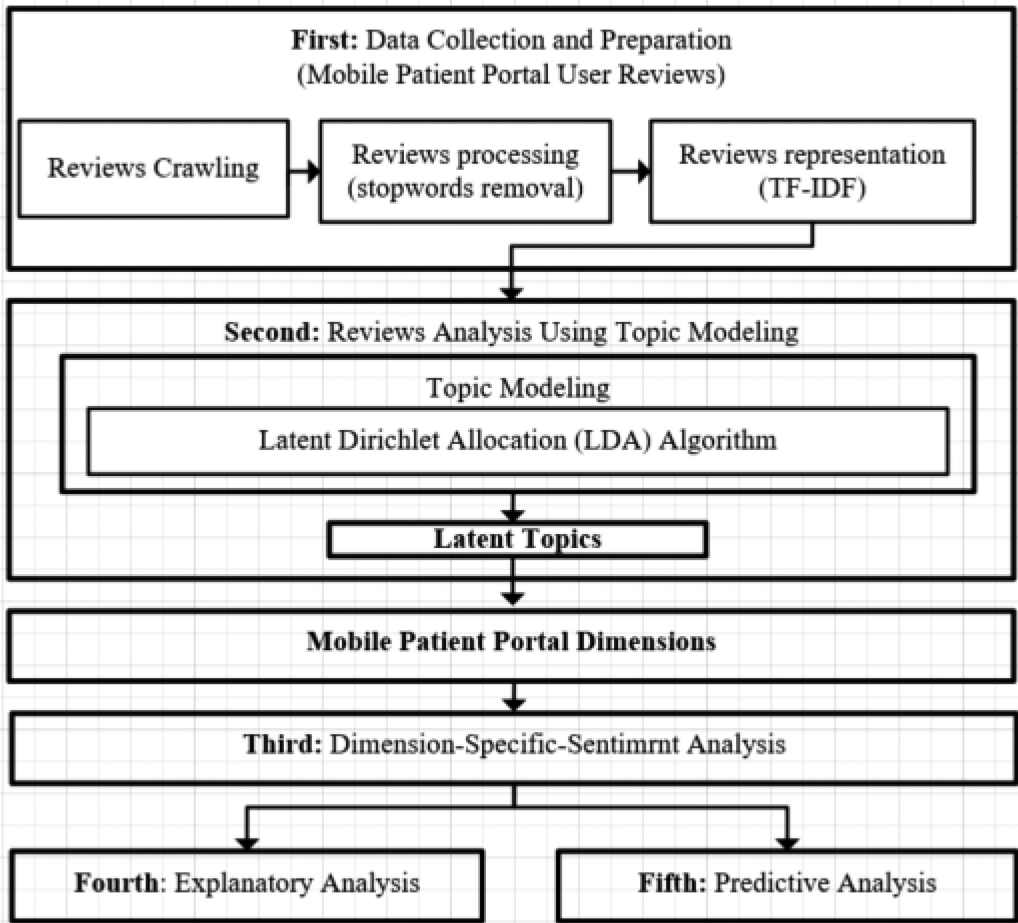

Fig. 2. Architecture of our text-mining-based method [68].

### 3.1 Data Collection and Preparation

In this study, the target population is mobile patient-portal users. The patient portal selected as the empirical setting for this research is Epic's MyChart, selected because Epic is replacing other vendors in the EHR market and beginning to establish a single-vendor landscape. Reportedly, Epic has at least partial health information for over 51% of the U.S. population [26]. The MyChart mobile app is available for Apple and Android devices. The data were collected from Apple iTunes store and Play store, where the online reviews posted by users were gathered using APIs. We developed a web crawler to collect data automatically. Through this process, we obtain our data set consisting of 3,475 reviews. When preprocessing the data, we removed stop words and represented each document using the well-known Term Frequency Inverse Document Frequency (TF-IDF) weighting scheme [69]. The TF-IDF<sub>*i,j*</sub> weighting scheme assigns to word *i* a weight in document *j* that is (1) highest when word *i* occurs many times within a small number of documents (thus lending high discriminating power to those documents), (2) lower when the word occurs fewer times in a document, or occurs in many documents (thus, offering a less pronounced relevance signal), and (3) lowest when the word occurs in virtually all documents [70]. Specifically,

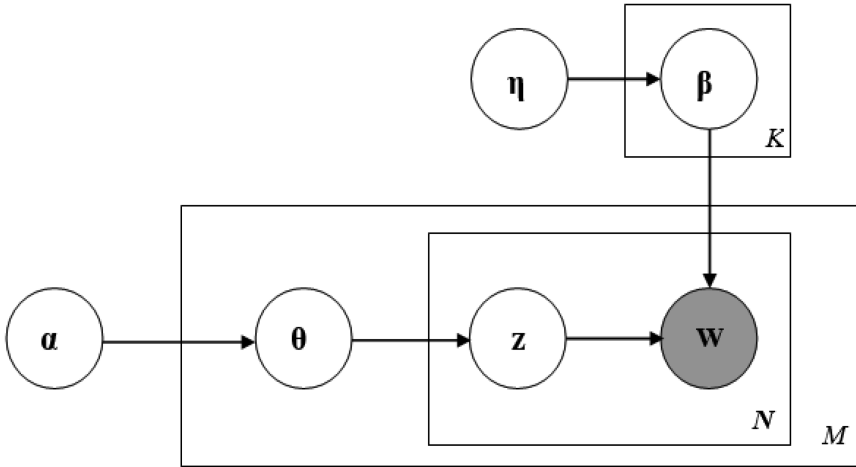

Fig. 3. Graphical model of LDA.

TF-IDF weight of a word  $i$  in a document  $j$  is

$$Fi, j * \log \left( \frac{N}{DF} \right), \quad (1)$$

where  $Fi, j$  is the frequency of the word  $i$  in the document  $j$ ,  $N$  indicates the number of documents in the corpus, and  $DF$  is the number of documents that contain word  $i$ .

### 3.2 Topic Modeling: LDA

Topic models are statistically based algorithms for discovering the main themes (i.e., set of topics) that describe a large and unstructured collection of documents. Topic models allow us to summarize textual data at a scale that is impossible to tackle by human annotation. We selected the Latent Dirichlet Allocation (LDA) model, the most common topic model currently in use, due to its conceptual advantage over other latent-topic models [35]. The model generates automatic summaries of topics in terms of a discrete probability distribution over words for each topic, and it also infers per-document discrete distributions over topics. The interaction between the observed documents and the hidden topic structure is manifest in the probabilistic generative process associated with LDA. This generative process can be thought of as a random process that is assumed to have produced the observed document [71]. To illustrate the results of LDA, let  $M$ ,  $K$ ,  $N$ , and  $V$  be the number of documents in a collection, the number of topics, the number of words in a document, and the vocabulary size, respectively. The first result is an  $M \times K$  matrix, where the weight  $w_{m,k}$  is the association between a document  $d_m$  and a topic  $t_k$ . In our case, the documents are user reviews for the patient portal MyChart app (i.e., we integrated the reviews of the app in a data file and treated each user review as a single document) ( $M = 3,475$ ). The second result is an  $N \times K$  matrix, where the weight  $w_{n,k}$  is the association between a word  $w_n$  and a topic  $t_k$ . The notations *Dirichlet*( $\cdot$ ) and *Multinomial*( $\cdot$ ) represent Dirichlet and multinomial distributions with parameter ( $\cdot$ ), respectively. The graphical representation of LDA is shown in Figure 3, and the corresponding generative process is shown below:

The notation  $\beta_t$  is the  $V$ -dimensional word distribution for topic  $t$ , and  $\theta_d$  is the  $K$ -dimensional topic proportion for document  $d$ . The notations  $\eta$  and  $\alpha$  represent the hyperparameters of the corresponding Dirichlet distributions.

**ALGORITHM 1:** Generative Process of LDA.

- 
- (1) For each topic  $t \in \{1, \dots, K\}$ ,
    - (a) draw a distribution over vocabulary words  
 $\beta_t \sim \text{Dirichlet}(\eta)$ .
  - (2) For each document  $d$ ,
    - (a) draw a vector of topic proportions  
 $\theta_d \sim \text{Dirichlet}(\alpha)$ .
    - (b) For each word  $w_n$  in document  $d$ , where  
 $n \in \{1, \dots, N\}$ ,
      - (i) draw a topic assignment  
 $z_n \sim \text{Multinomial}(\theta_d)$ ;
      - (ii) draw a word  $w_n \sim \text{Multinomial}(\beta_{z_n})$ .
- 

**3.3 Dimension-specific-sentiment Analysis**

After extracting the dimensions expressed in user feedback using topic mining, we conducted dimension-oriented sentiments analysis (see Tables 4 and 5 in Section 4 for the topics and dimensions extracted). For that purpose, we developed dimension-specific word lists based on the topics associated with each dimension. We then split a review into sentence level units and analyze whether at least one word related to a dimension is contained in the sentences. For each sentence of the review fulfilling this condition, we then calculate the sentiment polarity using the Harvard General Inquirer lexicon [72]. Particularly, we consider the word lists for positive (pos) and negative (neg) words in the lexicon to determine the sentiment polarity using Equation (2) [73]. As shown in Equation (2), sentiment polarity ranges from  $-1$  (negative) to  $1$  (positive). However, in this study, we normalized the output so that for negative sentiments polarity, we assign  $-1$  (negative sentiment) and for the positive ones, we assign  $1$ . If a specific dimension is not mentioned in a review, then we treat its sentiment as  $0$ .

$$\text{Polarity} = (\text{pos} - \text{neg}) / (\text{pos} + \text{neg}) . \quad (2)$$

**3.4 Explanatory Analysis**

Patient portal use in large part is based on patient satisfaction. According to the Technology Acceptance Model (TAM) theory, an individual's intention to use a system that in turn leads into actual system use is determined by user satisfaction (i.e., perceived usefulness and perceived ease of use) [74]. Therefore, to show the impact of the dimensions discovered on patient portal use, in this section, we empirically studied the relationship between these dimensions and patient satisfaction. Particularly, we conducted explanatory analysis study to explore the relationship between the dimensions discovered and user ratings. We intended to test the following: *Hypothesis (H1): Sentiments expressed about dimensions discovered are statistically correlated with user ratings (H1a), and some of the dimensions have stronger correlation with user rating than others (H1b)*. Users are more likely to be satisfied and perceive patient portal service is useful when their dimension-oriented sentiments are positive.

To test our hypothesis, we perform a multiple linear regression analysis as it is suitable for multicategory ordinal dependent variable (i.e., user ratings). We ran a linear regression model with the user ratings of the patient portal (i.e., the variable ReviewRate) as the dependent variable and the sentiments for the dimensions as independent variables. We also added the length of each review as a control variable (i.e., the variable length\_words).

Table 3. Model Configurations

Configuration	Description
Dimension-specific sentiment	Model that considers the different dimension-oriented sentiment variables
Bag-of-words (Base line)	Classical text-mining approach based on a bag-of-words model

### 3.5 Predictive Analysis

In the predictive analysis, we intended to test the following Hypothesis (H2): Sentiments expressed about dimensions have predictive power for user rating (i.e., user' satisfaction) (H2a), and this predictive power is higher compared to a classical text-mining approach (H2b). Toward that end, we conduct two experiments. In the first experiment, we adopt a linear regression model as it is suitable for the ordinal dependent variable with more than two categories (i.e., user rating variable). We ran the model but with two different configurations: Dimension-specific-sentiment and bag of words (as base line) configurations as shown in Table 3. To evaluate the models, we use Root-mean-squared Error (RMSE), R-2, and AIC metrics, three metrics commonly used to evaluate regression tasks.

In the second experiment, we reduce the number of categories in the dependent variable (i.e., user rating variable) into just two categories, satisfied and unsatisfied, so we can run the *logistic regression model*. To this end, we focus only on low rating (i.e., 1- and 2-star) and high rating (i.e., 4- and 5-star) user reviews. Thus, we remove those neutral reviews (i.e., 3-star) from the data set to end with 1,155 reviews distributed as 305 low rating reviews and 850 high rating reviews. Since users tend to write high rating reviews when they are satisfied and low rating reviews when they are not, we divide the data set into two classes, satisfied that corresponds 4- and 5-star user reviews and unsatisfied that corresponds 1- and 2-star reviews. When preprocessing the data, we removed stop words and represented user reviews using bag of worlds. Specifically, the weight of a word in a user review is the frequency of the word in the user review and is 0 otherwise.

A problem with representing user reviews as vectors of words is the large number of features obtained. In our case, the number of the words generated from our data set is 2,024. If we use all the words as features, then such a large number of features can potentially cause the issue of overfitting. We hence perform feature selection using the commonly used Chi-square ( $X^2$ ) method. The Chi-square method evaluates features individually by measuring their Chi-square statistic with respect to the classes of the target variable (i.e., user satisfaction). We use only the features that have a Chi-square test score that is statistically significant at the 0.05 level (i.e., p-value < 0.05). Since feature selection must be performed using only training data, we use only the training data set for feature selection and test data for evaluation. Like experiment 1, we created two configurations (see Table 3), *Dimension-specific-sentiment* and *bag of words*. To evaluate the models, we used two different arrangements. First, we randomly split our data set into 70% training and 30% testing partitions. Second, we performed 10-fold cross validation. In both arrangements, we chose four evaluation metrics, precision, recall, accuracy, and F1 Score. The precision metric evaluates the prediction accuracy by dividing the number of positive samples that correctly predicted as positive (TP) on the total number of both TP and those mistakenly classified as positive (FP). Note that the drawback of the precision is that it does not account for those who are incorrectly classified as negative samples.

$$Precision = TP / (TP + FP) . \quad (3)$$

However, the recall metric evaluates the prediction accuracy by dividing the number of TP on the total number of both TP and those are incorrectly classified as negative (FN).

$$Recall = TP / (TP + FN). \quad (4)$$

The accuracy metric measures the percentage of those correctly classified as positive or negative examples:

$$Accuracy = (TP + TN) / (TP + TN + FP + FN). \quad (5)$$

The last metric is F1 score. F1 Score is the weighted average of Precision and Recall. Therefore, this score takes both false positives and false negatives into account:

$$F1\ Score = 2 * (Recall * Precision) / (Recall + Precision). \quad (6)$$

## 4 RESULTS AND EMPIRICAL STUDY

In this section, we summarize the results of the extraction of the topics from user feedback using LDA analysis, discuss how these topics could be related to existing literature and higher-level concepts in theories, and discuss the results of the Explanatory and predictive analysis.

### 4.1 Topics Extracted

Table 4 presents the 25 topics learned by our LDA model, along with the assigned labels. The top 10 words in each topic are visualized using word clouds, where the font size corresponds to the probability of the word occurring in the topic. The first author conducted the initial labeling of topics, which was then confirmed by the second author. Labeling was initially based on the identification of a logical connection between these 10 most frequently occurring words for a topic. For example, in Table 4, the topic name *Sync with health apps* is based on the word *sync*, weighted 0.6%, *app* weighted 0.7%, and *health*, weighted 0.7%. Once specified, a candidate topic label was then further tested by investigating the reviews highly associated with that topic. To demonstrate the presence of these topics across the review dataset, we also show in Table 4 the frequency percentage of each topic (i.e., the total number of frequency of terms in the topic divided by the total number of frequency of terms in the data corpus). The results show that the most frequent topics in the dataset are *T11: Communication with doctors* (11.5%), *T8: Appointments* (10.5%), *T24: View test results* (9.3%), *T9: Appointments* (9.2%), *T3: Send messages* (9.1%), *T20: Push notifications* (8.9%), *T15: Appointments schedule* (8.8%), *T22: Notifications* (8.7%), *T18: Access results* (8.6%), *T13: User friendly app* (7.7%), *T12: Log in using touch id* (7.6%), *T23: Send messages* (7.2%), *T5: Visit summaries* (7%), *T17: App needs fix* (7%) and *T4: Update data* (6.9%).

To remove redundancy in topics obtained (i.e., T8, T9, T15, T21) and to aggregate related topics into a higher-level dimension, the topics obtained were then mapped into 11 dimensions, shown with descriptions and examples from user feedback in Table 5. The dimensions are listed by the descending order of their frequency to show the most important (frequent) dimensions. The mappings between the topics and the dimensions are often many-to-one. For example, technical-problem-related topics (*Fix app fast*, *Server connecting problems*, and *App needs fix*) were mapped to the *Technical problems* dimension. The *Send messages*, *Communication with doctors*, *View letters and messages from doctors*, and *Email health providers* topics related to communication with doctors were mapped to *Communication with health providers*. Likewise, *Appointments*, *Appointments schedule* topics were mapped to the *Appointments* dimension. For some topics, however, the mappings are one-to-one. For instance, the topic *Update data* was mapped to the dimension *Update medical data*, the topic *Visit summaries* to the dimension *Medical summaries (data to knowledge presentation)*, and *Sync with health apps* to *Integration with health apps*.

Table 4. Topics Extracted Using LDA

Topic	Top 10 words	Frequency Percentage
T1: Notifications	<b>ios, app, option, notifications, town, mychart, health, small, recently, reason</b>	6.1%
T2: Touch id	<b>touch, id, password, app, good, like, support, new, pretty, available</b>	6.7%
T3: Send messages	<b>app, feature, message, information, office, sent, schedule, new, messages, love</b>	9.1%
T4: Update data	<b>login, update, app, data, right, account, fix, error, away, latest</b>	6.9%
T5: Visit summaries	<b>app, msg, use, logon, innovative, practical, update, password, visit, summaries</b>	7%
T6: Sync with health apps	<b>app, manage, health, sync, ipad, push, love, care, point, password</b>	6.3%
T7: Fix app fast	<b>fix, app, update, crap, open, completely, fast, health, tried, plz</b>	6.6%
T8: Appointments	<b>says, app, available, appointments, chart, wish, great, able, information, like</b>	10.5%
T9: Appointments	<b>app, able, option, work, make, log, appointments, providers, appointment, making</b>	9.2%
T10: Server connecting problems	<b>server, problem, connect, saying, keeps, fix, communicating, app, worked, later</b>	6.7%
T11: Communication with doctors	<b>app, messages, doctors, doctor, medical, great, love, send, use, communicate</b>	11.5%
T12: Log in using touch id	<b>app, touch, id, health, medical, account, apple, log, fix, lets</b>	7.6%
T13: User friendly app	<b>log, app, ability, user, health, make, friendly, nice, needs, load</b>	7.7%
T14: ipad version	<b>ipad, updated, needs, way, app, version, work, especially, ihealth, fixed</b>	6.4%
T15: Appointments schedule	<b>app, use, called, update, doctor, schedule, star, care, appointments, really</b>	8.8%
T16: View letters and messages from doctors	<b>like, letters, organized, view, doctors, messages, password, love, use, update</b>	5.6%
T17: App needs fix	<b>app, new, let, read, time, happy, change, needs, fix, pls</b>	7%
T18: Access results	<b>log, app, mychart, safari, unable, hospital, provider, access, phone, results</b>	8.6%
T19: Touch id	<b>app, months, setting, card, able, id, everytime, touch, using, option</b>	6%
T20: Push notifications	<b>version, like, love, using, push, app, need, apple, use, older</b>	8.9%
T21: Appointments	<b>good, appointment, app, shuts, website, record, onpatient, sooner, document, looked</b>	5.9%
T22: Notifications	<b>like, notifications, doctor, update, medical, provider, app, good, fix, resolution</b>	8.7%
T23: Send messages	<b>conditions, terms, app, message, sent, login, loaded, warning, people, work</b>	7.2%
T24: View test results	<b>results, test, use, computer, appointments, app, nice, browser, doctor, view</b>	9.3%
T25: Email health providers	<b>touch, write, gone, providers, app, emails, health, setup, soon, activating</b>	5.5%



Table 5. Dimensions of users' experiences

Dimension	Description	Examples from users' feedback (as written)	Frequency Percent- age (aggregated topics)
Communication with health providers [T3, T11, T16, T23, T25]	Support communication with health providers so patients can send messages to physicians and medical staff.	<ul style="list-style-type: none"> <li>–No ability to send messages to your doctor with any kind of attachment.</li> <li>–Provides quick convenient communications with providers.</li> <li>–No ability to send messages to your doctor with any kind of attachment.</li> </ul>	38.9%
Appointments [T8, T9, T15, T21]	Patients' ability to request, schedule and view appointments with health providers.	<ul style="list-style-type: none"> <li>–I once was able to request; schedule appointments but I no longer have that capability.</li> <li>–Still can't make appointments.</li> </ul>	34.4%
Push notifications [T1, T20, T22]	Push notifications for when healthcare providers send messages and responses and when test results are ready to be viewed.	<ul style="list-style-type: none"> <li>–Push Notifications (for iOS) are not there for things like messages from my healthcare provider, test results, and other things.</li> <li>–Necessary improvements are push notifications for when test results are ready to be viewed, and notifications for when your doctor sends reply.</li> <li>–I can't believe that there has been another update and still no push notifications!</li> </ul>	23.7%
Log in using touch id [T2, T12, T19]	Touch ID support for logging into health provider instead of entering password to log-in.	<ul style="list-style-type: none"> <li>–I would really like Touch ID support for logging into my provider instead of entering my password every time.</li> <li>–I liked the app before and would had given it 4-5 stars with successful integration of the TouchID feature.</li> </ul>	20.3%
Technical problems [T7, T10, T17]	Technical issues like problems communicating with the server.	<ul style="list-style-type: none"> <li>–it can't communicate with the server.</li> <li>–I get a server error whenever I open the app. Works fine in a browser. Please fix.</li> </ul>	20.3%
Access and view data [T18, T24]	Give patient access to their medical records and information like lab results and prescriptions.	<ul style="list-style-type: none"> <li>–There is extremely limited access to your records and information.</li> <li>–One of the benefits is to be able to access your health information from any location and this has not been the case for me.</li> <li>–Does not allow you to view scanned lab results</li> </ul>	17.9%
User friendly app [T13]	Simple and friendly user interface.	<ul style="list-style-type: none"> <li>–Very user friendly to me. I really like it.</li> <li>–the UI is simple in appearance, which is user friendly</li> </ul>	7.7%
Medical summaries (data to knowledge presentation) [T5]	Providing patients with health summary about their health status.	<ul style="list-style-type: none"> <li>–It's already bad enough that I can't access ER summaries on the app.</li> <li>–The computer-based app allows you to see the office visit summaries but that is missing that feature.</li> <li>–I am able to get medical summaries.</li> <li>–This app is a perfect summary of all of my health issues.</li> </ul>	7%
Update medical data [T4]	Giving patients the ability to update and correct their medical information like vaccines and shots.	<ul style="list-style-type: none"> <li>–Giving us ability to update vaccines would be appreciated.</li> <li>–So it be great if I could update my shots and other medical issues.</li> <li>–Gives no ability to patient/user to correct/update data. Have to request medical personnel to make changes, which in my case they often don't do.</li> </ul>	6.9%

(Continued)

Table 5. Continued

Dimension	Description	Examples from users' feedback (as written)	Frequency Percent- age (aggregated topics)
ipad version [T14]	App version for iPad.	–I use MyChart on both my iPhone and iPad. –This would be a good app if worked on the iPad in Landscape mode.	6.4%
Integration with health apps [T6]	Support integration with health apps like apple app so patients can export/synchronize their health data to/with health apps.	–No sync with Apple Health. Without that, what is the point. –Completely outdated and lacks important features such as apple health app integration. –I should be able to export the relevant data straight to the Health app. –I really wish it would sync with the health app so we can see how stuff like our blood pressure has changed overtime.	6.3%

Table 6. Descriptive Statistics ( $N = 3,475$ )

Variable	Mean	Std. Dev.	First quartile	Median	Third quartile
Notification	0.0000	0.2173	0.0000	0.0000	0.0000
Touch_id	-0.0015	0.1352	0.0000	0.0000	0.0000
Communication_health_Provider	0.1918	0.5572	0.0000	0.0000	1.0000
Update_data	-0.0107	0.1456	0.0000	0.0000	0.0000
Medical_summaries	0.0030	0.2137	0.0000	0.0000	0.0000
Integration_health_apps	-0.0007	0.0617	0.0000	0.0000	0.0000
Appointment	0.1400	0.5030	0.0000	0.0000	0.0000
Technical problem	-0.1659	0.3742	0.0000	0.0000	0.0000
User_friendly	0.1499	0.4394	0.0000	0.0000	0.0000
ipad_version	0.0000	0.0390	0.0000	0.0000	0.0000
Access_data	0.2177	0.4482	0.0000	0.0000	0.0000
length_words	29.0928	26.7994	13.000	22.000	36.000

## 4.2 Explanatory Analysis

As explained in the research methodology Section 3.4, we ran a regression model to test the Hypothesis (**H1**) that *Sentiment expressed about dimensions discovered are statistically correlated with user ratings*. The descriptive statistics (Mean, Standard Deviation, first, Median, and third quartile) of the independent variables (i.e., dimensions extracted) and the control variable are shown in Table 6.

Table 7 shows the Pearson correlations between the variables. The correlations between the independent variables are low. Hence, there is absence of multicollinearity between the predictors in a regression model.

We developed the following regression model, Equation (7):

$$\begin{aligned}
 ReviewRate_i = & \alpha_i + \beta_1. Notification + \beta_2. Touch\_id + \beta_3. Communication\_health\_Pr ovider + \beta_4. \\
 & Update\_data + \beta_5. Medical\_summaries + \beta_6. Integration\_health\_apps + \beta_7. Appointment + \beta_8. \\
 & Technicalproblem + \beta_9. User\_friendly + \beta_{10}. ipad\_version + \beta_{11}. Access\_data + \beta_{12}. \\
 & length\_words + \epsilon_i.
 \end{aligned} \tag{7}$$

Results reported a significant positive effect of nine dimensions on the user ratings of the patient portal (see Table 8). These dimensions are *Notification*, *Touch\_id*, *Communication\_health\_Provider*,

Table 7. Variable Correlations

Variable	1	2	3	4	5	6	7	8	9	10	11	12	13
1 ReviewRate	<b>1.00</b>												
2 Notification	0.09	<b>1.00</b>											
3 Touch_id	0.05	0.05	<b>1.00</b>										
4 Communication_health_Provider	0.45	0.04	0.02	<b>1.00</b>									
5 Update_data	0.07	0.05	0.08	0.05	<b>1.00</b>								
6 Medical_summaries	0.15	-0.03	0.00	0.09	0.03	<b>1.00</b>							
7 Integration_health_apps	-0.03	0.00	0.00	0.03	0.00	0.00	<b>1.00</b>						
8 Appointment	0.40	0.13	0.03	0.26	0.05	0.07	0.00	<b>1.00</b>					
9 Technical problem	0.59	-0.01	-0.02	0.15	-0.05	0.01	-0.01	0.12	<b>1.00</b>				
10 User_friendly	0.37	-0.02	0.02	0.03	0.02	0.03	0.00	0.05	0.16	<b>1.00</b>			
11 ipad_version	0.01	0.00	0.00	-0.04	0.00	0.00	0.00	0.00	0.00	0.00	<b>1.00</b>		
12 Access_data	0.40	0.09	0.04	0.21	0.08	0.09	0.01	0.38	0.21	0.03	0.00	<b>1.00</b>	
13 length_words	-0.12	-0.03	0.01	0.00	-0.02	-0.03	0.09	0.03	0.02	-0.14	-0.01	0.03	<b>1.00</b>

Table 8. Linear Regression Results, Explaining User Rating by Means of Textual Review Dimensions

	Coefficient	Standard Error	t	P-value
Constant	3.7563	0.044	86.091	0.000
<b>Notification</b>	0.3313	0.114	2.910	0.004
<b>Touch_id</b>	0.4044	0.181	2.231	0.026
<b>Communication_health_Provider</b>	0.7781	0.046	16.868	0.000
<b>Update_data</b>	0.4083	0.169	2.413	0.016
<b>Medical_summaries</b>	0.5805	0.115	5.041	0.000
Integration_health_apps	-0.6275	0.397	-1.581	0.114
<b>Appointment</b>	0.5867	0.054	10.879	0.000
<b>Technical problem</b>	1.8350	0.068	26.907	0.000
<b>User_friendly</b>	0.9189	0.057	16.157	0.000
ipad_version	0.8531	0.625	1.365	0.173
<b>Access_data</b>	0.4860	0.061	8.010	0.000
length_words	-0.0055	0.001	-5.974	0.000
Number of observations	1314			
<b>R-square</b>	0.664			
<b>Adj R-square</b>	0.661			

*Update\_data*, *Medical\_summaries*, *appointment*, *Technical problem*, *User\_friendly*, and *Access\_data*. While the impact of the other two variables (*Integration\_health\_apps* and *ipad\_version*) on user ratings is statistically insignificant, the regression results in an  $R^2$  of 0.664, suggesting the significant correlation of the nine dimensions with user ratings (*H1a*). Results also revealed that the dimensions *Notification*, *Communication\_health\_Provider*, *Medical\_summaries*, *appointment*, *Technical problem*, *User\_friendly*, and *Access\_data* have stronger correlation with user rating than *Touch\_id* and *Update\_data* (*H1b*).

### 4.3 Predictive analysis

Table 9 shows the results of the predictive analysis using linear regression. Both RMSE and R-2 values indicate that *dimension-specific-sentiment model* (0.88, 0.67) has a better prediction

Table 9. Linear Regression Prediction Results

Model	Root Mean Squared Error (RMSE)	R-2	AIC
Dimension-specific-sentiment	0.88	0.67	2408
Base line: bag of words	3177789447404	-4.38	2728

Table 10. Logistic Regression Prediction Results

Configuration	Satisfied				Unsatisfied			
	Accuracy	Precision	Recall	F1	Precision	Recall	F1	
70% training and 30% testing partitions								
Dimension-specific-sentiment	0.92	0.97	0.91	0.94	0.81	0.94	0.87	
Base line: bag of words	0.84	0.85	0.93	0.89	0.79	0.61	0.69	
10-fold cross validation								
Dimension-specific-sentiment	0.94	0.98	0.83	0.95	0.88	0.94	0.90	
Base line: bag of words	0.86	0.89	0.94	0.91	0.92	0.65	0.7	

performance compared with the base line, bag-of-words model (3177789447404, -4.38). Additionally, AIC metric shows that *dimension-specific-sentiment model* (2408) is better than the base line model (2728) (i.e., a model with lower AIC score is better). Likewise, the results of logistic regression (see Table 10) shows that dimension-specific-sentiment configuration (accuracy 0.92 and 0.94, respectively, when splitting data into 70% training and 30% testing and when using 10-fold cross validation), outperforms the bag-of-words model (accuracy 0.84 and 0.86). Therefore, sentiments expressed about dimensions extracted are useful in predicting user rating (i.e., user' satisfaction) (*H2a*) and have a better prediction power against traditional text-mining model (*H2b*).

## 5 DISCUSSION AND IMPLICATIONS

As healthcare providers transition to population health management, they recognize that engaging patients is essential to success. So far, they have largely relied on elementary patient portals to do this. These basic, single-source portals do little to engage patients in their care. Next-generation patient portals are needed to gain the attention of patients and move toward effective population health management.

### 5.1 Managerial Implications

The findings of this study have implications for practice that can help design more successful patient portal app that promotes user self-care and sustainable use. *Improved communications with health providers, integration with health apps, giving patients full access to their records and health information* (such as lab results, prescription, and patient's information), *providing patients with medical summaries of all their health issues*, as well as *allowing patients to correct/update medical data* such as vaccines are important features and support that fit the requirements of the self-care task (i.e., enable patients to take responsibility for their care). Thus, keep patients as healthy as possible (i.e., improving the health of the population), and minimize healthcare expenditures, which will assist with achieving key goals of Triple Aim.

Findings, specifically *Access and view data, Update medical data, and Medical summaries (data to knowledge presentation)* dimensions, confirm that current patient portals do not fit the requirements of self-care task. In essence, current patient portals do not present a unified view of patients' medical information, depicting patient improvement trends and historical patterns, but

offering little or no opportunity for patients to update or add relevant follow-up information on their current condition, response to drugs or treatment, or other indicators of their health status. In this regard, current patient-portal technology must be adapted to match the tasks that the user must perform (task-technology fit). The technology must create a *one-stop shopping experience* for patients, so they can enter one portal and access all their medical, laboratory, insurance, and related information [75]. In essence, future portals need to *organize and summarize patient data from multiple health providers and consumer devices such as fitness trackers* (i.e., Task-structure and Task-technology design directives [14]). For example, users stated that “*Great to be able to access information from most of my doctors in one place.*” This matches the findings by Ammenwerth, Schnell-Inderst and Hoerbst [76] who stated that access to information is one facet of patient satisfaction. The users also reported the ability to check test results as an important feature of patient portal. This is consistent with literature where patients reported higher level of satisfaction with patient portals that allow patients to view their test results [77, 78]. The ability to view medication and related information is related to patient satisfaction. For example, users stated “*I love this app it’s important to keep track of all medications*” and “*Love this app it’s so easy to find my daughter medication and all info.*” The ability to order prescription/medication refills has also been reported as one of the features related to patient satisfaction with patient portal as stated in the following reviews: “*very useful for accessing health info, prescriptions, and requesting refills*” and “*I love this cause I don’t have to wait for an appointment for refills are wait to see results.*” This finding matches the existing literature where portal users reported highest satisfaction for medication refills [78, 79].

Further, our findings for *Integration with health apps* show that it is crucial to view the patient-portal app as a component within a holistic health system. In this system, the app should be integrated with other health apps (e.g., fitness apps). Patient portal users expressed their need to have patient portal app integrated with health apps as stated by this user review: “*The MyChart app should integrate with Health on iOS. Ideally, lab results would be sourced from MyChart and feed into Apple’s Health iOS.*” This could be mapped to the design directives *Task-Technology*, “The system design should incorporate use of reliable technology to support all critical components of a self-care task,” and *Task-structure*, “The system design should accommodate the supporting elements of the external structure in support of the Task and help overcome deficiencies in structural environment with which self-care processes are embedded” [14].

Additionally, results indicate that patient-portal systems need to notify patients of their health status during the use of the app, *Push notifications*. It is critical that patient portal provides the ability to set reminders and receive notification regarding different aspects of care delivery. Likewise, and consistent with literature, *communication with health providers* has been reported as one of the most important factors related to patient satisfaction with patient portal [48, 50, 80]. The ability to *schedule appointments* has been also reported as an important dimension of patient portal use as stated in this user feedback: “*It’s very helpful it’s easy to use for making appointment.*” Last but not least, our findings report that some dimensions (i.e., Notification, Touch\_id, Communication\_health\_Provider, Update\_data, Medical\_summaries, appointment, Technical problem, User\_friendly, and Access\_data) have more influence on user satisfaction than others.

## 5.2 Methodological and Theoretical Implications

*Methodologically*, this study exploits users’ feedback in form of online reviews. In essence, the design of patient portals as health behavioral change support systems requires understanding of user context [81]. In this regard, user involvement is key in patient portal, which can help shift the focus of innovation from pure technology to the context of daily life [13]. We hence used unique data set collected from the actual use of patient portal. Instead of manually analyzing and coding

the reviews, which is time-consuming and subjective, we used text mining, more specifically the LDA algorithm for topic modeling, to automatically extract dimensions about users' experience from large amounts of text data. Additionally, we conducted a sentiment-based explanatory and predictive analysis to show the impact of the dimensions extracted on user rating.

*Theoretically*, our dimensions extracted intersect with pertinent literature in the following dimensions: *Communication with health providers* (e.g., Ralston et al. [79], Neuner et al. [82], Abanes and Adams [83], Wade-Vuturo et al. [84]), *Technical problems* (e.g., Liu et al. [85]), and *Access and view data* (e.g., Ralston et al. [79], Sorondo et al. [42]). Grounding these dimensions in users' feedback helps provide another empirical basis and further demonstrates their importance for patient-portal systems. While the other dimensions may not directly be mentioned in literature, they could be related to higher level concepts in information systems theories. For example, *User-friendly*, *log in using touch id*, *ipad\_version*, and *Integration with health apps* could be related to "perceived ease of use" and "effort expectancy" concepts in Technology acceptance model (TAM) [86] and Unified theory of acceptance and use of technology (UTAUT), respectively [87]. Allowing users to log in using their fingerprint, having an ipad version from the app, and integrating the app with other health apps so patients can export/synchronize their relevant health data to/with the patient portal app will let them feel that the app is easy to use, and less effort is needed to enter their medical data like glucose level to the app.

Further, *Integration with health apps*, push notification, update medical data, medical summaries (data to knowledge presentation), and appointments are critical components and requirements of a self-care task. These dimensions could be related to the Socio-Technical design theory-based design directives proposed by El-Gayar et al. [14] and Task-Technology fit theory [40] (see Sections 2.1 and 2.2). In essence, these dimensions have the potential to improve the correspondence between patient portal functionality as a healthcare consumer centric tool and the self-care task requirements of users (i.e., Self-care Task-Patient Portal Technology Fit).

Therefore, our findings inform the Socio-Technical design theory (see Section 2.1) and Task-Technology Fit Theory (see Section 2.2). The findings indicate that the current practice in developing patient portal as a self-care enhancement tool stresses a techno-centric approach, focusing primarily on the technical aspects, while neglecting other important structural and social ones. The findings of the study highlight the importance of the usage context (i.e., structural aspects of the task) beside the technical aspects in implementing patient portal apps. Especially in the era of *the Internet of Things (IoT)* and with the advancement of modern medical and wearable systems, integrating mobile patient portals with medical devices and other health apps has become an essential requirement for the design of mobile patient portal. It is thus paramount to view patient portal app as a component within a holistic health system. In this system, the app should enable patients to export and communicate their readings and information with physicians, and it should be integrated with other health apps (i.e., Apple health apps), medical devices such as glucose meters and insulin pumps, and other information systems such as mobile devices and servers.

Further, the results inform the humanization of healthcare framework, specifically *Togetherness/isolation* and *Agency/passivity* dimensions [88]. In particular, the findings confirmed that current patient portals lack social support aspects. Future patient portals need to offer more social-related aspects including connections to support groups or communities focused on their specific health conditions or wellness concerns. Such connection can strengthen consumers' ability and behavior to actively manage their own health as they are more likely to perform better when they perceive social support and observe others' performance. Moreover, such special support groups can help achieve *togetherness* dimension of humanization of healthcare and mitigate *isolation*, "user feel themselves separated from their sense of belonging with others" [88]. For example, portals can help connect patients to others with the same chronic conditions so they can share experience and



support. This in turn helps motivate patients to stay on track with their care programs and get more involved in their healthcare management. As a result, increase their sense of *agency* in which they do not experience themselves as merely passive or totally determined but have the possibility of freedom to be and act within certain limits, *Agency/passivity* dimension [88]. Therefore, patient portals should be designed to provide patients with a humanizing care that is actively facilitating participation in their health process “*enhancing agency through increased patient participation.*”

## 6 CONCLUDING REMARKS

This study aims to systematically analyze user-generated contents of patient portal and discover the dimensions of user experience. We adopt a text-mining-based approach to leveraging online user reviews as a primary data source. Given the importance of Epic patient portal, we use MyChart mobile application as a problem domain. To demonstrate the importance of the dimensions discovered, we empirically examined the relationship between these dimensions and patient satisfaction. Overall, the findings indicated that nine dimensions are significantly correlated with user satisfaction. Moreover, results reported that *Notification, Communication\_health\_Provider, Medical\_summaries, appointment, Technical problem, User\_friendly, and Access\_data* dimensions have stronger influence on user rating compared with *Touch\_id* and *Update\_data*. Thus, this research contributes to existing knowledge of patient portal by (1) providing insights into adopting mobile patient portals that can help advance the research in this area and (2) informing the literature of user acceptance of patient portals and patient satisfaction by supporting some of the dimensions found in the previous research studies and inferring new ones that influence patient satisfaction.

Overall, results indicated that MyChart implementations burden the user by requiring different registrations, access requirements, and user interfaces for each provider and patient (i.e., each provider has its own MyChart system, which requires creating a login for each). Improving the patient-care experience (one of the Triple Aim goals) requires a single-source technology solution for patient portals, enabling users to access all their information in one presentation. Patient portals needs to become more patient-centered and user-friendly technology that put a patient’s whole health history into one easy-to-navigate online portal. Engaging patients and integrating their health data from multiple sources will enable them to contribute to their health maintenance and help to achieve the Triple Aim goals of improving the health of a population at reduced cost. Results also show consistent participation from treatment providers and being proactive in keeping all the MyChart information updated are essential pieces of the equation to improve the quality of healthcare provided.

Transformative health technologies are innovations that fundamentally change care (including self-care) and care delivery in ways that add substantial value for individuals and society (Detmer [4]). For patient portals to gain this type of power, they will need the enhanced functionality identified by the patients and users of the technology. Multiple stakeholders, including patients, providers, and government, will play key roles in developing mobile patient portal technology, to overcome the barriers to fully enabling this technology to support population health, and assist in achieving the goals of healthcare’s Triple Aim. This research contributes the patient perspective to considering the vision of future m-patient portal development and increased usage. When patient portals allow *iterative communication between patients and health providers, notify patients regarding health issues, allow patients to schedule and track appointments, integrate patients with health apps, and transform clinical measurements and observations into meaningful and actionable information*, fundamental changes in health technology usage, healthcare delivery, and self-care by patients become possible.

To enhance the generalizability of the research findings to other brands of patient portals, we selected Epic’s MyChart patient portal as the empirical setting of the study. MyChart is considered

one of the leading patient portal solutions on the market. It comes in as a top performer in the Best in KLAS 2019 rankings [89]. Moreover, data were collected from two sources, *Apple* and *Google Play Stores*. To further explore the generalizability of our results, as a future research, we aim to extend the dataset to include reviews from other mobile patient portal applications. As a limitation of the study, we acknowledge narrow framings of portal use in future work, investigating, for instance, the role of specific geographic regions, device types, or medical conditions that might further impact patterns of use and perceived experiences.

## REFERENCES

- [1] Centers for Disease Control and Prevention. 2013. The State of Aging and Health in America. Retrieved from <https://www.cdc.gov/aging/pdf/state-aging-health-in-america-2013.pdf>.
- [2] N. Yaraghi. 2015. The benefits of health information exchange platforms: Measuring the returns on a half a billion dollar investment. *Center for Technology Innovation at Brookings*.
- [3] K. Davis, K. Stremikis, D. Squires, and C. Schoen. 2018. Mirror, mirror on the wall, 2014 update: How the U.S. health care system compares internationally. Retrieved from <http://www.commonwealthfund.org/publications/fund-reports/2014/jun/mirror-mirror>.
- [4] D. Detmer, M. Bloomrosen, B. Raymond, and P. Tang. 2008. Integrated personal health records: Transformative tools for consumer-centric care. *BMC Med. Inform. Decision Making* 8, 1 (2008), 45.
- [5] G. L. Gaskin, C. A. Longhurst, R. Slayton, and A. K. Das. 2011. Sociotechnical challenges of developing an interoperable personal health record: Lessons learned. *Appl. Clin. Inform.* 2, 4 (2011), 406–419.
- [6] M. Pratt. 2018. The future of patient portals. *Medical Economics*. MJH Life Sciences.
- [7] J. Eschler, L. S. Liu, L. M. Vizer, J. B. McClure, P. Lozano, W. Pratt, and J. D. Ralston. Designing asynchronous communication tools for optimization of patient-clinician coordination. In *AMIA Annu Symp Proc*. 543–52. PMID: 26958188; PMCID: PMC4765629.
- [8] J. Eschler, L. Kendall, K. O’Leary, L. M. Vizer, P. Lozano, J. B. McClure, W. Pratt, and J. D. Ralston. Shared calendars for home health management. In *Proceedings of the 18th ACM Conference on Computer Supported Cooperative Work and Social Computing (CSCW’15)*. 1277–1288. <https://doi.org/10.1145/2675133.2675168>
- [9] L. Kendall, J. Eschler, P. Lozano, J. B. McClure, L. M. Vizer, J. D. Ralston, and W. Pratt. Engineering for reliability in at-home chronic disease management. *AMIA Annu Symp Proc*. 777–86. PMID: 25954384; PMCID: PMC4419963.
- [10] D. Halo. 2018. Patients Grow Comfortable With Digital Health Tools, CDW Finds. Retrieved from <http://www.healthit.myindustrytracker.com/en/article/170850>.
- [11] S. Djamasbi, W. Li, M. Traietti, L. C. T. Tran, V. Valcour, J. Wyatt, and F. Yuan. 2015. Web Experience and Growth. In *Twenty First Americas Conference on Information Systems (AMCIS’15)*. AIS.
- [12] V. Wilson, and S. Djamasbi. 2015. Human-computer interaction in health and wellness: Research and publication opportunities. *AIS Trans. Hum.-Comput. Interact.* 7, 3 (2015), 97–108.
- [13] J. Thackara. 2001. The design challenge of pervasive computing. *Interactions* 8, 3 (2001), 46–52.
- [14] O. El-Gayar, S. Sarnikar, and A. Wahbeh. 2013. On the design of IT-enabled self-care systems: A socio-technical perspective. In *2013 46th Hawaii International Conference on System Sciences*. 2484–2493. DOI : [10.1109/HICSS.2013.425](https://doi.org/10.1109/HICSS.2013.425)
- [15] D. B. Wesley, L. Schubel, C.-J. Hsiao, S. Burn, J. Howe, K. Kellogg, A. Lincoln, B. Kim, and R. Ratwani. 2019. A socio-technical systems approach to the use of health IT for patient reported outcomes: Patient and healthcare provider perspectives. *J. Biom. Informat.: X* 4 (2019), 100048.
- [16] S. Qureshi, M. Liu, and D. Vogel. 2005. A grounded theory analysis of e-collaboration effects for distributed project management. In *Proceedings of the 38th Annual Hawaii International Conference on System Sciences*. 264c–264c. DOI : [10.1109/HICSS.2005.18](https://doi.org/10.1109/HICSS.2005.18)
- [17] S. Qureshi, and P. Keen. 2005. Activating knowledge through electronic collaboration: Vanquishing the knowledge paradox. *IEEE Trans. Profess. Commun.* 48, 1 (2005), 40–54.
- [18] S. Qureshi and C. Noteboom. 2006. Adaptation in distributed projects: Collaborative processes in digital natives and digital immigrants. In *Proceedings of the 39th Annual Hawaii International Conference on System Sciences (HICSS’06)*. 202c–202c. DOI : [10.1109/HICSS.2006.36](https://doi.org/10.1109/HICSS.2006.36)
- [19] J. A. Chevalier, and D. Mayzlin. 2006. The effect of word of mouth on sales: Online book reviews. *J. Market. Res.* 43, 3 (2006), 345–354.
- [20] J. Yang, R. Sarathy, and J. Lee. 2016. The effect of product review balance and volume on online Shoppers’ risk perception and purchase intention. *Decis. Supp. Syst.* 89, (2016), 66–76.
- [21] Y. Yu, W. Duan, and Q. Cao. 2013. The impact of social and conventional media on firm equity value: A sentiment analysis approach. *Decis. Supp. Syst.* 55, 4 (2013), 919–926.

- [22] M. Al-Ramahi, Y. Chang, O. El-Gayar, and J. Liu. 2015. Predicting big movers based on online stock forum sentiment analysis. In *Twenty-First Americas Conference on Information Systems (AMCIS'15)*.
- [23] M. Al-Ramahi and C. Noteboom. 2018. A systematic analysis of patient portals adoption, acceptance and usage: The trajectory for triple aim? In *Hawaii International Conference on System Sciences (HICSS-51)*.
- [24] C. Noteboom and M. Al-Ramahi. 2018. What are the gaps in mobile patient portal? Mining users feedback using topic modeling. In *Hawaii International Conference on System Sciences (HICSS-51)*.
- [25] A. Wahbeh, M. Al-Ramahi, C. Noteboom, and T. Nasrallah. 2019. Discovering patient portal features critical to user satisfaction: A systematic analysis. In *Hawaii International Conference on System Sciences (HICSS-52)*.
- [26] R. Koppel, and C. U. Lehmann. 2014. Implications of an emerging EHR monoculture for hospitals and healthcare systems. *J. Amer. Med. Inform. Assoc.* 22, 2 (2014), 465–471.
- [27] Y. Guo, S. J. Barnes, and Q. Jia. 2017. Mining meaning from online ratings and reviews: Tourist satisfaction analysis using latent dirichlet allocation. *Tourism Manage.* 59, (2017), 467–483.
- [28] M. Allamanis and C. Sutton. 2013. Why, when, and what: Analyzing stack overflow questions by topic, type, and code. In *2013 10th Working Conference on Mining Software Repositories (MSR'13)*. 53–56. DOI : [10.1109/MSR.2013.6624004](https://doi.org/10.1109/MSR.2013.6624004)
- [29] K. Bajaj, K. Pattabiraman, and A. Mesbah. 2014. Mining questions asked by web developers. In *Proceedings of the 11th Working Conference on Mining Software Repositories*. 112–121. <https://doi.org/10.1145/2597073.2597083>
- [30] M. Linares-Vásquez, C. McMillan, D. Poshyvanik, and M. Grechanik. 2014. On using machine learning to automatically classify software applications into domain categories. *Empir. Softw. Eng.* 19, 3 (2014), 582–618.
- [31] E. Linstead, C. Lopes, and P. Baldi. 2008. An application of latent Dirichlet allocation to analyzing software evolution. In *Seventh International Conference on Machine Learning and Applications*. 813–818. DOI : [10.1109/ICMLA.2008.47](https://doi.org/10.1109/ICMLA.2008.47)
- [32] S. Grant, J. R. Cordy, and D. B. Skillicorn. 2011. Reverse engineering co-maintenance relationships using conceptual analysis of source code. In *18th Working Conference on Reverse Engineering*. 87–91. DOI : [10.1109/WCRE.2011.20](https://doi.org/10.1109/WCRE.2011.20)
- [33] G. Maskeri, S. Sarkar, and K. Heafield. 2008. Mining business topics in source code using latent dirichlet allocation. In *Proceedings of the 1st India Software Engineering Conference*. 113–120. <https://doi.org/10.1145/1342211.1342234>
- [34] K. Tian, M. Reville, and D. Poshyvanik. 2009. Using latent dirichlet allocation for automatic categorization of software. In *6th IEEE International Working Conference on Mining Software Repositories*. 163–166. DOI : [10.1109/MSR.2009.5069496](https://doi.org/10.1109/MSR.2009.5069496)
- [35] D. M. Blei, A. Y. Ng, and M. I. Jordan. 2003. Latent dirichlet allocation, *J. Mach. Learn. Res.* 3 (Jan. 2003), 993–1022.
- [36] H. Leavitts. 1964. Applied organisation change in industry: Structural, technical, and human approaches. *New Perspectives in Organisational Research*. John Wiley.
- [37] K. Lyytinen, and M. Newman. 2008. Explaining information systems change: A punctuated socio-technical change model. *European J. Information Systems* 17, 6 (2008), 589–613.
- [38] L. Tang, Z. Yu, X. Zhou, H. Wang, and C. Becker. 2011. Supporting rapid design and evaluation of pervasive applications: Challenges and solutions. *Person. Ubiq. Comput.* 15, 3 (2011), 253–269.
- [39] M. Rigby, A. Georgiou, H. Hyppönen, E. Ammenwerth, N. de Keizer, F. Magrabi, and P. Scott. 2015. Patient portals as a means of information and communication technology support to patient-centric care coordination—The missing evidence and the challenges of evaluation. *Yearbook Med. Inform.* 24, 01 (2015), 148–159.
- [40] D. L. Goodhue and R. L. Thompson. 1995. Task-technology fit and individual performance. *MIS Quart.* 19, 2 (1995), 213–236.
- [41] T. Otte-Trojel, A. de Bont, T. G. Rundall, and J. van de Klundert. 2014. How outcomes are achieved through patient portals: A realist review. *J. Amer. Med. Inform. Assoc.* 21, 4 (2014), 751–757.
- [42] B. Sorondo, A. Allen, S. Fathima, J. Bayleran, and I. Sabbagh. 2016. Patient portal as a tool for enhancing patient experience and improving quality of care in primary care practices. *eGEMS* 4, 1 (2016), 1262.
- [43] C. S. Kruse, K. Bolton, and G. Freriks. 2015. The effect of patient portals on quality outcomes and its implications to meaningful use: A systematic review. *J. Med. Internet Res.* 17, 2 (2015), e44.
- [44] E. Ammenwerth, P. Schnell-Inderst, and A. Hoerbst. 2012. The impact of electronic patient portals on patient care: A systematic review of controlled trials. *J. Med. Internet Res.* 14, 6 (2012), e162.
- [45] S. Kim, K.-H. Lee, H. Hwang, and S. Yoo. 2015. Analysis of the factors influencing healthcare professionals' adoption of mobile electronic medical record (EMR) using the unified theory of acceptance and use of technology (UTAUT) in a tertiary hospital. *BMC Med. Inform. Decis. Making* 16, 1 (2015), 12.
- [46] D. J. Amante, T. P. Hogan, S. L. Pagoto, and T. M. English. 2014. A systematic review of electronic portal usage among patients with diabetes. *Diabetes Technol. Therap.* 16, 11 (2014), 784–793.
- [47] R. G. Mishuris, M. Stewart, G. M. Fix, T. Marcello, D. K. McInnes, T. P. Hogan, J. B. Boardman, and S. R. Simon. 2015. Barriers to patient portal access among veterans receiving home-based primary care: A qualitative study. *Health Expect.* 18, 6 (2015), 2296–2305.
- [48] A. Brédart, J. L. Kop, F. Efficace, A. Beaudreau, T. Brito, S. Dolbeault, N. Aaronson, and E. Q. O. L. Group. 2015. Quality of care in the oncology outpatient setting from patients' perspective: A systematic review of questionnaires' content and psychometric performance. *Psycho-Oncol.* 24, 4 (2015), 382–394.

- [49] A. M. K. Ahmad, M. A. S. Alghamdi, S. A. S. Alghamdi, O. Z. Alsharqi, and H. M. Al-Borie. 2016. Factors influencing patient satisfaction with pharmacy services: An empirical investigation at king fahd armed forces hospital, Saudi Arabia. *Int. J. Bus. Manage.* 11, 9 (2016), 272.
- [50] S. Waters, S. J. Edmondston, P. J. Yates, and D. F. Gucciardi. 2016. Identification of factors influencing patient satisfaction with orthopaedic outpatient clinic consultation: A qualitative study. *Manual Ther.* 25 (2016), 48–55.
- [51] K. J. O’Leary, R. K. Sharma, A. Killarney, L. S. O’Hara, M. E. Lohman, E. Culver, D. M. Liebovitz, and K. A. Cameron. 2016. Patients’ and healthcare providers’ perceptions of a mobile portal application for hospitalized patients. *BMC Med. Inform. Decis. Making* 16, 1 (2016), 123.
- [52] J. M. García-Gómez, I. de la Torre-Díez, J. Vicente, M. Robles, M. López-Coronado, and J. J. Rodrigues. 2014. Analysis of mobile health applications for a broad spectrum of consumers: A user experience approach. *Health Inform. J.* 20, 1 (2014), 74–84.
- [53] L. Guerra-Reyes, V. M. Christie, A. Prabhakar, A. L. Harris, and K. A. Siek. 2016. Postpartum health information seeking using mobile phones: Experiences of low-income mothers. *Maternal Child Health J.* 20, 1 (2016), 13–21.
- [54] M. W. Zhang, R. Ho, S. E. Cassin, R. Hawa, and S. Sockalingam. 2015. Online and smartphone-based cognitive behavioral therapy for bariatric surgery patients: Initial pilot study. *Technol. Health Care* 23, 6 (2015), 737–744.
- [55] S. Moore, and D. Jayewardene. 2014. The use of smartphones in clinical practice: Sally Moore and Dharshana Jayewardene look at the rise in the use of mobile software at work. *Nurs. Manage.* 21, 4 (2014), 18–22.
- [56] X. Liang, Q. Wang, X. Yang, J. Cao, J. Chen, X. Mo, J. Huang, L. Wang, and D. Gu. 2011. Effect of mobile phone intervention for diabetes on glycaemic control: a meta-analysis. *Diabetic Med.* 28, 4 (2011), 455–463.
- [57] B. B. Green, A. J. Cook, J. D. Ralston, P. A. Fishman, S. L. Catz, J. Carlson, D. Carrell, L. Tyll, E. B. Larson, and R. S. Thompson. 2008. Effectiveness of home blood pressure monitoring, web communication, and pharmacist care on hypertension control: A randomized controlled trial. *J. Amer. Med. Assoc.* 299, 24 (2008), 2857–2867.
- [58] A. G. Logan, M. J. Irvine, W. J. McIsaac, A. Tisler, P. G. Rossos, A. Easty, D. S. Feig, and J. A. Cafazzo. 2012. Effect of home blood pressure telemonitoring with self-care support on uncontrolled systolic hypertension in diabetics: Novelty and significance. *Hypertension* 60, 1 (2012), 51–57.
- [59] N. Shah, J. Jonassaint, and L. De Castro. 2014. Patients welcome the sickle cell disease mobile application to record symptoms via technology (SMART). *Hemoglobin* 38, 2 (2014), 99–103.
- [60] G. Lee, J. Y. Park, S.-Y. Shin, J. S. Hwang, H. J. Ryu, J. H. Lee, and D. W. Bates. 2016. Which users should be the focus of mobile personal health records? Analysis of user characteristics influencing usage of a tethered mobile personal health record. *Telemed. e-Health* 22, 5 (2016), 419–428.
- [61] L. Pfeifer Vardoulakis, A. Karlson, D. Morris, G. Smith, J. Gatewood, and D. Tan. 2012. Using mobile phones to present medical information to hospital patients. In *Proceedings of the SIGCHI Conference on Human Factors in Computing Systems*. 1411–1420. <https://doi.org/10.1145/2207676.2208601>
- [62] P. C. Dykes, D. L. Carroll, A. C. Hurley, A. Benoit, F. Chang, R. Pozzar, and C. A. Caligian. 2013. Building and testing a patient-centric electronic bedside communication center. *J. Gerontol. Nurs.* 39, 1 (2013), 15–19.
- [63] A. S. McAlearney, C. J. Sieck, J. L. Hefner, A. M. Aldrich, D. M. Walker, M. K. Rizer, S. D. Moffatt-Bruce, and T. R. Huerta. 2016. High touch and high tech (HT2) proposal: Transforming patient engagement throughout the continuum of care by engaging patients with portal technology at the bedside. *JMIR Res. Protocols* 5, 4 (2016), e221.
- [64] Y.-H. Lu, L.-Y. Lee, Y.-L. Chen, H.-I. Cheng, W.-T. Tsai, C.-C. Kuo, C.-Y. Chen, and Y.-B. Huang. 2017. Developing an app by exploiting web-based mobile technology to inspect controlled substances in patient care units. *BioMed Res. Int.* 2017, Article 3195369 (2017), 6 pages. <https://doi.org/10.1155/2017/3195369>
- [65] P. Pierleoni, L. Pernini, A. Belli, and L. Palma. 2014. An android-based heart monitoring system for the elderly and for patients with heart disease. *Int. J. Telemed. Appl.* 2014, Article 625156 (2014), 11 pages. <https://doi.org/10.1155/2014/625156>
- [66] L. Neubeck, G. Coorey, D. Peiris, J. Mulley, E. Heeley, F. Hersch, and J. Redfern. 2016. Development of an integrated e-health tool for people with, or at high risk of, cardiovascular disease: The Consumer Navigation of Electronic Cardiovascular Tools (CONNECT) web application. *Int. J. Med. Inform.* 96, (2016), 24–37.
- [67] K.-Y. Goh, C.-S. Heng, and Z. Lin. 2013. Social media brand community and consumer behavior: Quantifying the relative impact of user-and marketer-generated content. *Inform. Syst. Res.* 24, 1 (2013), 88–107.
- [68] M. A. Al-Ramahi, J. Liu, and O. F. El-Gayar. 2017. Discovering design principles for health behavioral change support systems: A text mining approach. *ACM Trans. Manage. Inform. Syst.* 8, 2–3 (2017).
- [69] E. Haddi, X. Liu, and Y. Shi. 2013. The role of text pre-processing in sentiment analysis. *Procedia Comput. Sci.* 17, (2013), 26–32.
- [70] C. D. Manning, P. Raghavan, and H. Schütze. 2008. *Introduction to Information Retrieval*. Cambridge University Press.
- [71] Y. Bao, and A. Datta. 2014. Simultaneously discovering and quantifying risk types from textual risk disclosures. *Manage. Sci.* 60, 6 (2014), 1371–1391.

- [72] P. J. Stone, D. C. Dunphy, and M. S. Smith. 1966. *The General Inquirer: A Computer Approach to Content Analysis*. MIT Press, Oxford, UK.
- [73] P. C. Tetlock, M. Saar-Tsechansky, and S. Macskassy. 2008. More than words: Quantifying language to measure firms' fundamentals. *J. Finance* 63, 3 (2008), 1437–1467.
- [74] F. D. Davis. 1989. Perceived usefulness, perceived ease of use, and user acceptance of information technology. *MIS Quart.* 13, 3 (1989), 319–340.
- [75] S. Bouchard. 2018. Next-generation patient portals: Making population health management work. Retrieved from <http://www.healthcareitnews.com/news/next-generation-patient-portals-making-population-health-management-work>.
- [76] E. Ammenwerth, P. Schnell-Inderst, and A. Hoerbst. 2012. The impact of electronic patient portals on patient care: A systematic review of controlled trials. *J. Med. Internet Res.* 14, 6, (2012).
- [77] J. D. Ralston, J. Hereford, D. Carrell, and M. Moran. 2006. Use and satisfaction of a patient Web portal with a shared medical record between patients and providers. In *AMIA Annu Symp Proc. 2006*, 1070. PMID: 17238689; PMCID: PMC1839721.
- [78] C. L. Goldzweig, G. Orshansky, N. M. Paige, A. A. Towfigh, D. A. Haggstrom, I. Mlake-Lye, J. M. Beroes, and P. G. Shekelle. 2013. Electronic patient portals: Evidence on health outcomes, satisfaction, efficiency, and attitudes: A systematic review. *Ann. Internal Med.* 159, 10 (2013), 677–687.
- [79] J. D. Ralston, D. Carrell, R. Reid, M. Anderson, M. Moran, and J. Hereford. 2007. Patient web services integrated with a shared medical record: Patient use and satisfaction. *J. Amer. Med. Inform. Assoc.* 14, 6 (2007), 798–806.
- [80] C. Y. Osborn, L. S. Mayberry, S. A. Mulvaney, and R. Hess. 2010. Patient web portals to improve diabetes outcomes: A systematic review. *Curr. Diabetes Rep.* 10, 6 (2010), 422–435.
- [81] H. Oinas-Kukkonen, and M. Harjumaa. 2009. Persuasive systems design: Key issues, process model, and system features. *Commun. Assoc. Inform. Syst.* 24, 1 (2009), 28.
- [82] J. Neuner, M. Fedders, M. Caravella, L. Bradford, and M. Schapira. 2015. Meaningful use and the patient portal: Patient enrollment, use, and satisfaction with patient portals at a later-adopting center. *Amer. J. Med. Qual.* 30, 2 (2015), 105–113.
- [83] J. J. Abanes, and S. Adams. 2014. Using a web-based patient-provider messaging system to enhance patient satisfaction among active duty sailors and Marines seen in the psychiatric outpatient clinic: A pilot study. *Nurs. Clin. North Amer.* 49, 1 (2014), 91–103.
- [84] A. E. Wade-Vuturo, L. S. Mayberry, and C. Y. Osborn. 2012. Secure messaging and diabetes management: Experiences and perspectives of patient portal users. *J. Amer. Med. Inform. Assoc.* 20, 3 (2012), 519–525.
- [85] J. Liu, L. Luo, R. Zhang, and T. Huang. 2013. Patient satisfaction with electronic medical/health record: A systematic review. *Scand. J. Caring Sci.* 27, 4 (2013), 785–791.
- [86] F. D. Davis. 1989. Perceived usefulness, perceived ease of use, and user acceptance of information technology. *MIS Quart.* 13, 3 (1989), 319–340.
- [87] V. Venkatesh, M. G. Morris, G. B. Davis, and F. D. Davis. 2003. User acceptance of information technology: Toward a unified view. *MIS Quart.* 27, 3 (2003), 425–478.
- [88] L. Todres, K. T. Galvin, and I. Holloway. 2009. The humanization of healthcare: A value framework for qualitative research. *Int. J. Qual. Studies Health Well-being* 4, 2 (2009), 68–77.
- [89] S. Heath. 2020. Epic MyChart Patient Portal Snags Best in KLAS 2019 Ranking. Retrieved from <https://patientengagementthit.com/news/epic-mychart-patient-portal-snags-best-in-klas-2019-ranking>.

Received March 2019; revised February 2020; accepted April 2020