



UWS Academic Portal

Impact of hardware impairments on the performance of millimeter-wave massive MU-MIMO systems with distributed antennas

Belaoura, Widad; Ghanem, Khalida ; Shakir, Muhammad Zeeshan; Qaraqe, Khalid A.

Published in:

Proceedings of the 8th IEEE International Conference on Communications and Networking

DOI:

[10.1109/ComNet47917.2020.9306107](https://doi.org/10.1109/ComNet47917.2020.9306107)

Published: 11/01/2021

Document Version

Peer reviewed version

[Link to publication on the UWS Academic Portal](#)

Citation for published version (APA):

Belaoura, W., Ghanem, K., Shakir, M. Z., & Qaraqe, K. A. (2021). Impact of hardware impairments on the performance of millimeter-wave massive MU-MIMO systems with distributed antennas. In *Proceedings of the 8th IEEE International Conference on Communications and Networking: ComNet 2020* (IEEE Conference Proceedings). IEEE. <https://doi.org/10.1109/ComNet47917.2020.9306107>

General rights

Copyright and moral rights for the publications made accessible in the UWS Academic Portal are retained by the authors and/or other copyright owners and it is a condition of accessing publications that users recognise and abide by the legal requirements associated with these rights.

Take down policy

If you believe that this document breaches copyright please contact pure@uws.ac.uk providing details, and we will remove access to the work immediately and investigate your claim.

Belaoura, W., Ghanem, K., Shakir, M. Z., & Qaraq, K. A. (2021). Impact of hardware impairments on the performance of millimeter-wave massive MU-MIMO systems with distributed antennas. In *Proceedings of the 8th IEEE International Conference on Communications and Networking: ComNet 2020* (IEEE Conference Proceedings). IEEE. <https://doi.org/10.1109/ComNet47917.2020.9306107>

“© © 2020 IEEE. Personal use of this material is permitted. Permission from IEEE must be obtained for all other uses, in any current or future media, including reprinting/republishing this material for advertising or promotional purposes, creating new collective works, for resale or redistribution to servers or lists, or reuse of any copyrighted component of this work in other works.”

Impact of Hardware Impairments on the Performance of Millimeter-Wave Massive MU-MIMO Systems with Distributed Antennas

Author 1, Author 2, Author 3, and Author 4

Abstract—The impact of hardware impairments play an crucial role in any practical communication systems, yet they are generally omitted when investigating the performance of distributed massive multiple input multiple output (MIMO) systems. In particularly, for millimeter-Wave (mm-Wave) bands, no study has been addressed yet. To overcome this limitation, in this paper a mm-Wave distributed massive multi-user (MU) MIMO system based-hybrid beamforming structure, in which the residual hardware impairments have been incorporated in the transmitter processing, is presented. At each base station (BS), a zero-forcing (ZF) baseband processing is designed over the effective channel to efficiently remove the multi-user (MU) interference. The results show that, relative to the co-located mm-Wave massive MIMO with the same antenna configurations, mm-Wave distributed MIMO achieves a significantly higher performance while reducing the impingement of hardware practical defects.

Index Terms—mm-Wave band, hardware impairments, distributed antennas array, MU-MIMO, hybrid beamforming.

I. INTRODUCTION

Nowadays, wireless communication networks faces a growing demand of multimedia data traffics. The migration towards high-frequency bands, such as the millimeter-Wave (mm-Wave), has been highlighted a possible solutions to mitigate the issue at hand [1]. The utilization of the mm-Wave band has greatly attracted attention from the research community since its can provide huge bandwidth and hold the possibility of incorporating multiple antennas, which can lead to rates of multiple Gbps (gigabit-per-second) [2].

The need for higher data rate for next generation wireless systems has driven researchers to propose an emerging technology known as massive Multiple-Input Multiple-Output (MIMO) to compensate for the greater path loss at the mm-Wave bands [3]. In massive MIMO systems, a large number of antennas at the base station (BS) is simultaneously serving many tens of users by spatial multiplexing [4]. A major challenge in realizing massive MIMO is the co-location of many antennas on a single BS. In addition to the technological issue, placing numerous antennas close together creates a high degree of correlation between the channels [5], [6]. The aforementioned issue as well as the need to attain high gain in spectral efficiency (SE) has lead to the adoption of distributed antenna arrays (DAAs). DAAs have been successfully applied to cutting-edge technologies, such as the Cloud Radio Access Network (CRAN) [7], [8].

Recently, DAA massive MIMO communication was proposed as a way to achieve large performance gains for future

5G wireless communication systems [9], [10], in which the BS antennas are geographically distributed within a cell instead of being co-located in a single array in the cell center. In such architectures, the capacity and the coverage can be dramatically improved, as the users are closer to the antenna arrays [11]. Unfortunately, massive MIMO systems comes with the major disadvantage of sensitivity to hardware impairments in practical implementation such as in-phase/quadrature-phase (I/Q) imbalance, oscillator phase noise (PN), and power amplifier non-linearity at the transmitter [12]. In addition, with the availability of large bandwidth, mm-Wave systems also encounter issues in the large real-time baseband signal processing. The performance of mm-Wave MIMO systems is severely limited due to such issues and there exists a great need for the thorough analysis of its practical scenarios [13].

In mm-Wave massive MIMO systems, the full digital beamforming techniques usually require the same number of radio frequency (RF) chains as the number of antenna elements, while purely analog beamforming solutions suffer severe performance limitations [4], [14]. Therefore, to compromise between system performance and hardware limitations, hybrid beamforming architectures were proposed in [15] as a promising solution to significantly reduce the number of required RF chains without a major performance loss. Beamforming operations are decomposed into two cascaded stages, namely, the low-dimensional baseband beamforming and the high dimensional phase-only processing at the RF domain.

In this paper, for the first time in literature, we investigate the performance of the downlink distributed mm-Wave massive MU-MIMO system based on hybrid beamforming structure with the presence of hardware imperfections. Each antenna array is connected to a central processing unit (CPU) through a backhaul link, which enables coherent processing of the signal transmitted from the arrays. To the best of our knowledge, the impact of hardware impairments on the achievable rate of mm-Wave massive MIMO system with distributed antennas has not been studied before. The numerical results provided in the paper indicate two major insights. First, the largest number of distributed antenna gives the best overall performance, i.e. in a co-located antennas, distributing the antennas is better. Second there is a higher robustness against hardware imperfections of the proposed system especially at large number of transmit antennas.

The remainder of the paper is organized as follows. In Section II, we introduce the distributed mm-Wave massive

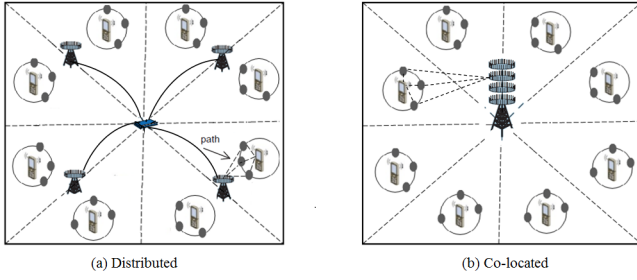

Fig. 1. Distributed and co-located mm-Wave massive MU-MIMO systems.

MU-MIMO system model, followed by Section III, in which we detail the hybrid beamforming design of the proposed system. Numerical experiments are presented in Section IV. Finally, the conclusions are given in Section V.

II. SYSTEM MODEL

We consider a single-cell, downlink mm-Wave massive MU-MIMO system, consisting of an array of M antennas, which can be either co-located at a macro BS or geographically distributed, as illustrated in Fig. 1. For the distributed scenario, it is assumed that the BSs uniformly located within an area of $A \times A m^2$ which is divided into 8 virtual sectors, where each sector contains one user. We assume a distributed massive MIMO scenario with N_{BS} sub-arrays of N_t antenna uniformly distributed across the cell at distances of d_c from the cell center, as shown in Fig.1 (a). This system is based on a hybrid beamforming architecture where each BS simultaneously communicates to K single-antenna users. In order to transmit a signal, each BS applies two consecutive beamforming operations $\mathbf{F}_T^j = \mathbf{F}^j \mathbf{W}^j$, where $\mathbf{W}^j \in C^{N_{RF} \times K}$ represents a digital beamforming performed in the baseband and $\mathbf{F}^j \in C^{N_t \times N_{RF}}$ is an analog beamformer. We assume $N_s \leq N_{RF}$ and the total number of streams is $N_s = K$. The received signal at the k^{th} user can be represented as

$$y_k = \sum_{j=1}^{N_{BS}} \mathbf{H}_k^j \mathbf{F}_k^j \mathbf{W}_k^j s_k^j + \sum_{k' \in K, k' \neq k} \sum_{j=1}^{N_{BS}} \mathbf{H}_k^j \mathbf{F}_k^j \mathbf{W}_k^j s_{k'}^j + n_k, \quad (1)$$

where s_k^j is the transmitted symbol from the j^{th} BS to the k^{th} user with unit power i.e $E[|s_k^j|^2]=1$, $\mathbf{H}_k^j \in C^{1 \times N_t}$ is the channel between the j^{th} BS and the k^{th} user, and n_k is the additive white Gaussian noise (AWGN) at the k^{th} user with zero mean and variance σ_k^2 . This model implicitly assumes ideal hardware. To consider the impact of transmit impairments which has been discussed in massive MIMO systems in [16], equation (1) can be modified as

$$y_k = \sum_{j=1}^{N_{BS}} \mathbf{H}_k^j (\mathbf{F}_k^j \mathbf{W}_k^j s_k^j + \boldsymbol{\eta}_t^j) + \sum_{k' \in K, k' \neq k} \sum_{j=1}^{N_{BS}} \mathbf{H}_k^j (\mathbf{F}_k^j \mathbf{W}_k^j s_{k'}^j + \boldsymbol{\eta}_t^j) + n_k, \quad (2)$$

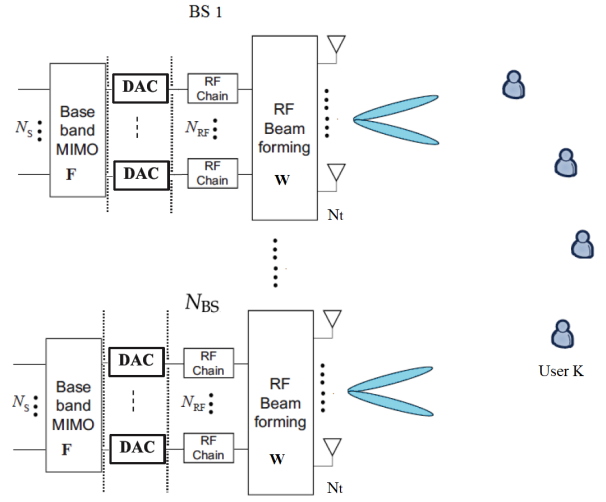

Fig. 2. Hardware impaired distributed MIMO transmitter based-hybrid beamforming structure.

where $\boldsymbol{\eta}_t^j$ refer to the impairments residue in the transmitter hardware for the j^{th} BS, which is assumed to be independent of the transmitted signal. This term is modeled as

$$\boldsymbol{\eta}_t^j \sim CN(0, (\mathbf{k}_t^j)^2 \text{diag}(|q_1^j|^2, \dots, |q_{N_t}^j|^2)), \quad (3)$$

where the coefficients \mathbf{k}_t^j are characterizing the level of impairments at the transmitter, with q_i denoting the i^{th} diagonal element of the signal covariance matrix \mathbf{Q}^j , where the covariance matrix is given as $\mathbf{Q}^j = \mathbb{E}[(\mathbf{F}_k^j \mathbf{W}_k^j)(\mathbf{F}_k^j \mathbf{W}_k^j)^H]$.

A. Channel model

In our proposed system, we adopt the widely used sparse mm-Wave channel model based on the extended Saleh-Valenzudela model [17], [18]. Each scatter contributes to only one path of propagation between the transmitter and the receiver which makes the number of paths equal to the number of scatters. Under this model, the channel between the j^{th} BS and k^{th} user, \mathbf{H}_k^j , can be given as

$$\mathbf{H}_k^j = \sqrt{\beta_k^j} \mathbf{G}_k^j \quad (4)$$

where β_k^j accounts for the large-scale channel coefficient and \mathbf{G}_k^j represents the small scale fading. The large scale fading factor can be defined as

$$\sqrt{\beta_k^j} = \left(\frac{d_0^j}{d_k^j}\right)^\nu \quad (5)$$

where d_k^j is the distance from the j^{th} BS to the k^{th} user, d_0^j is the minimal distance between the user and each BS, and ν is the path loss exponent. Under the Saleh-Valenzudela model, the channel \mathbf{G}_k^j could be expressed by

$$\mathbf{G}_k^j = \sqrt{N_t} \sum_{l=0}^{L-1} \alpha_l^j \mathbf{a}^j(\theta_l^j, \phi_l^j) \quad (6)$$

where α_l^j is the complex gain of the l^{th} path, L is the number of multi-paths components, $\mathbf{a}^j(\theta_l^j, \phi_l^j)$ stands for the transmit array steering vector, and θ_l^j, ϕ_l^j represent the azimuth and elevation angles of the l^{th} path, respectively. For simplicity, we use uniform planar arrays (UPAs), $\mathbf{a}^j(\theta_l^j, \phi_l^j)$ can be defined as:

$$\mathbf{a}^j(\theta_l^j, \phi_l^j) = \frac{1}{\sqrt{N_t}} [1, \dots, e^{j \frac{2\pi d}{\lambda} (N_t-1) \sin(\theta_l^j) \cos(\phi_l^j)}]^T \quad (7)$$

where λ represents the wavelength at the operating frequency, while d represents the inter-element antenna spacing. According to (2), the achievable rate of the network pertaining to the k^{th} user when incorporating the transmit impairments is defined as

$$R = \sum_{k=1}^K \log_2 \left(1 + \frac{|\sum_{j=1}^{N_{\text{BS}}} \mathbf{H}_k^j \mathbf{F}_k^j \mathbf{W}_k^j|^2 (\Phi^j)^{-1}}{\sigma_k^2 + \sum_{k' \neq k}^K |\sum_{j=1}^{N_{\text{BS}}} \mathbf{H}_k^j \mathbf{F}_{k'}^j \mathbf{W}_{k'}^j|^2 (\Phi^j)^{-1}} \right) \quad (8)$$

The hardware impairments are defined as

$$\Phi^j = \gamma (k_t^j)^2 (\mathbf{H}_k^j \mathbf{F}_k^j \mathbf{W}_k^j) (\mathbf{H}_k^j \mathbf{F}_k^j \mathbf{W}_k^j)^H \quad (9)$$

with γ is the signal-to-noise ratio (SNR).

III. HYBRID BEAMFORMING DESIGN

To alleviate the hardware constraints while realizing full potentials of mm-Wave massive MU-MIMO systems, we incorporate the hybrid beamforming in the proposed system. The digital zero forcing (ZF) beamforming is designed to maximize the data rate of the users as follows.

- The RF beamsteering at each BS \mathbf{F}^j is generated to maximize the desired signal power of each user, where each BS j selects the set of array response vectors pointing the AoAs of the L multi-trajets

$$\mathbf{F}^j = \mathbf{A}_t^j = [\mathbf{a}^j(\theta_1^j, \phi_1^j), \dots, \mathbf{a}^j(\theta_L^j, \phi_L^j)]^T. \quad (10)$$

- The BS digital beamforming \mathbf{W}^j is designed such that the MU interference is canceled. User k estimates its effective channel as $\mathbf{H}_e^j = \mathbf{H}_k^j \mathbf{F}^j$. Based on this effective channel, the ZF digital beamformer is given as

$$\mathbf{W}^j = (\mathbf{H}_e^j)^H (\mathbf{H}_e^j (\mathbf{H}_e^j)^H)^{-1}, \quad (11)$$

To satisfy the transmit power constraint, we normalize the columns of the BS digital beamforming \mathbf{W}^j such that

$$\mathbf{W}^j = \frac{\mathbf{W}^j}{\|\mathbf{F}^j \mathbf{W}^j\|_F}, \quad (12)$$

Hence, the hybrid beamforming matrix \mathbf{F}_T^j can be expressed as $\mathbf{F}_T^j = \mathbf{F}^j \mathbf{W}^j$.

IV. SIMULATION RESULTS

In this section, the achievable performance is investigated for the distributed and the co-located mm-Wave massive MU-MIMO system based-hybrid beamforming structure in the presence of hardware impairments. We assume an area of $200 \times 200 \text{ m}^2$ which is divided into 8 virtual sectors, where each sector contains one user with a minimum distance of 60 m from the cell center. We assume a distributed massive MIMO scenario with $N_{\text{BS}} = 4$ sub-arrays of $N_t = 32$ antennas. The BS are assumed to be uniformly distributed across the cell at distances of 50 m from the cell center. The sub-arrays are equipped with an equal number of antennas and $N_{\text{RF}} = 8$. Furthermore, we assume mm-Wave channel where the number of path is $L = 3$, the path loss component $\nu = 2$, and the carrier frequency is 28 GHz.

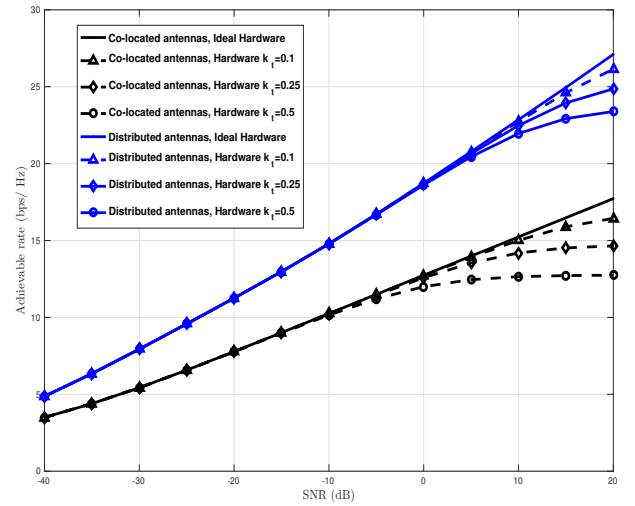

Fig. 3. Performance comparison of distributed and co-located mm-Wave massive MU-MIMO systems with different levels of impairments.

As illustrated in Fig. 3, the achievable rate of the distributed BS antennas configuration of mm-Wave massive MU-MIMO system is compared with co-locating antennas alternative with different levels of transmit impairments. In adopting distribution antennas, no correlation between the distributed arrays is assumed and each BS incorporates a hybrid beamforming structure, as previously mentioned. From Fig. 3, it is observed that, the gain in achievable rate brought from retaining distribution antennas configuration in mm-Wave massive MU-MIMO is significant over the co-located antennas counterpart. Furthermore, the presence of the practical imperfections induces a saturation phenomena in the achieved rate at relatively high SNR values. By contrast, the proposed system has higher robustness to such hardware deviations than the system with a co-located configuration. This validates the robustness of the distributed massive MIMO configuration for mm-Wave communications.

Fig. 4 shows the performance comparison of distributed and co-located mm-Wave massive MU-MIMO systems using

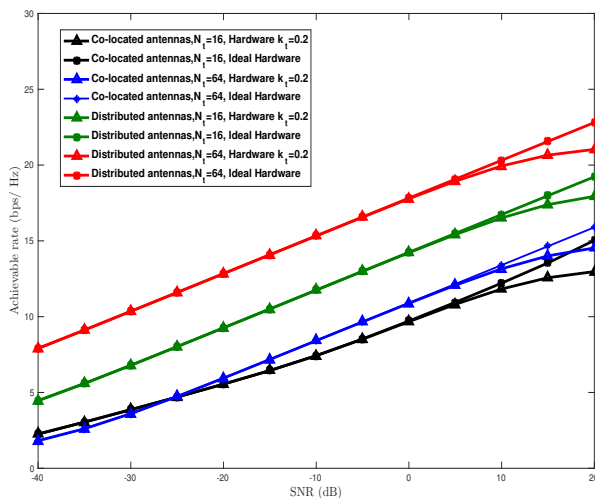

Fig. 4. Achievable rate performance comparison of distributed and co-located mm-Wave massive MU-MIMO systems with different antennas configurations.

either ideal hardware or imperfect hardware with $k_t = 0.2$ under different system configurations for $N_t = \{16, 64\}$. From the Fig. 4, it can be observed that the achievable rate of both systems is enhanced with increasing number of antennas but bring considerable gains for distributing antennas over cell areas, due to the spatial correlation arising from co-localizing antennas in mm-Wave massive MIMO, which substantiates the efficacy the distribution of antennas for mm-Wave MIMO system. Moreover, it is also observed that hardware imperfections cause small performance losses when the number of antennas large (i.e., $N_t = 64$). We note that an increment in the number of transmitted antennas can reduce the impact of hardware imperfections.

V. CONCLUSION

Although mm-Wave MIMO systems promise to offer larger bandwidth and unprecedented peak data rates, their implementation in realistic scenarios faces some important issues that need to be solved. The inevitable imperfections, emerging from the transceiver hardware, make the mm-Wave massive MIMO systems more challenging. In this paper, we investigated the impact of transmit hardware impairments on the performance of mm-Wave massive MU-MIMO systems using distributed BS antennas, by adopting hybrid beamforming architecture. The results have shown that the system with distribution configuration offers a higher data rate which scales linearly with SNR increase. The performance superiority of distributed massive MIMO over co-located counterpart, although confirmed, might be more difficult and more expensive to implement. Furthermore, the higher performance and robustness against hardware imperfections of the proposed solution with massive MIMO configurations has been demonstrated for mm-Wave communications.

ACKNOWLEDGMENT

“This publication was made possible in parts by Ooredoo Research Sponsorship 2015 and TAMUQ RRSRG 2019 internal funds. The statements made herein are solely the responsibility of the author[s].”

REFERENCES

- [1] S. Rangan, T. S. Rappaport, and E. Erkip, “Millimeter-wave cellular wireless networks: Potentials and challenges,” *Proceedings of the IEEE*, vol. 102, no. 3, pp. 366–385, 2014.
- [2] A. L. Swindlehurst, E. Ayanoglu, P. Heydari, and F. Capolino, “Millimeter-wave massive mimo: The next wireless revolution?” *IEEE Communications Magazine*, vol. 52, no. 9, pp. 56–62, 2014.
- [3] F. Rusek, D. Persson, B. K. Lau, E. G. Larsson, T. L. Marzetta, O. Edfors, and F. Tufvesson, “Scaling up mimo: Opportunities and challenges with very large arrays,” *IEEE Signal Processing Magazine*, vol. 30, no. 1, pp. 40–60, 2013.
- [4] T. L. Marzetta, “Noncooperative cellular wireless with unlimited numbers of base station antennas,” *IEEE Transactions on Wireless Communications*, vol. 9, no. 11, pp. 3590–3600, 2010.
- [5] K. T. Truong and R. W. Heath, “The viability of distributed antennas for massive mimo systems,” in *2013 Asilomar Conference on Signals, Systems and Computers*. IEEE, 2013, pp. 1318–1323.
- [6] W. Belaoura, K. Ghanem, and H. Bousbia-Salah, “Effect of spatial correlation on the ergodic capacity for downlink massive mu-mimo systems,” in *2017 6th International Conference on Systems and Control (ICSC)*. IEEE, 2017, pp. 183–186.
- [7] K. Chen and R. Duan, “C-ran the road towards green ran,” *China Mobile Research Institute, white paper*, vol. 2, 2011.
- [8] H. Q. Ngo, A. Ashikhmin, H. Yang, E. G. Larsson, and T. L. Marzetta, “Cell-free massive mimo versus small cells,” *IEEE Transactions on Wireless Communications*, vol. 16, no. 3, pp. 1834–1850, 2017.
- [9] E. Björnson, M. Matthaiou, A. Pitarokoilis, and E. G. Larsson, “Distributed massive mimo in cellular networks: Impact of imperfect hardware and number of oscillators,” in *2015 23rd European Signal Processing Conference (EUSIPCO)*. IEEE, 2015, pp. 2436–2440.
- [10] N. Akbar, E. Björnson, E. G. Larsson, and N. Yang, “Downlink power control in massive mimo networks with distributed antenna arrays,” in *2018 IEEE International Conference on Communications (ICC)*. IEEE, 2018, pp. 1–6.
- [11] W. Belaoura, K. Ghanem, and H. Bousbia-Salah, “Hybrid precoding for dl massive mu-mimo systems with distributed antenna deployments,” in *2017 IEEE International Symposium on Antennas and Propagation & USNC/URSI National Radio Science Meeting*. IEEE, 2017, pp. 1173–1174.
- [12] C. Studer, M. Wenk, and A. Burg, “Mimo transmission with residual transmit-rf impairments,” in *Smart Antennas (WSA), 2010 International ITG Workshop on*. IEEE, 2010, pp. 189–196.
- [13] X. Yang, M. Matthaiou, J. Yang, C.-K. Wen, F. Gao, and S. Jin, “Hardware-constrained millimeter-wave systems for 5g: Challenges, opportunities, and solutions,” *IEEE Communications Magazine*, vol. 57, no. 1, pp. 44–50, 2019.
- [14] L. Liang, W. Xu, and X. Dong, “Low-complexity hybrid precoding in massive multiuser mimo systems,” *IEEE Wireless Communications Letters*, vol. 3, no. 6, pp. 653–656, 2014.
- [15] A. Alkhateeb, O. El Ayach, G. Leus, and R. W. Heath, “Hybrid precoding for millimeter wave cellular systems with partial channel knowledge,” in *2013 Information Theory and Applications Workshop (ITA)*. IEEE, 2013, pp. 1–5.
- [16] E. Björnson, J. Hoydis, M. Kountouris, and M. Debbah, “Massive mimo systems with non-ideal hardware: Energy efficiency, estimation, and capacity limits,” *IEEE Transactions on Information Theory*, vol. 60, no. 11, pp. 7112–7139, 2014.
- [17] O. El Ayach, R. W. Heath, S. Rajagopal, and Z. Pi, “Multimode precoding in millimeter wave mimo transmitters with multiple antenna sub-arrays,” in *2013 IEEE Global Communications Conference (GLOBECOM)*. IEEE, 2013, pp. 3476–3480.
- [18] O. El Ayach, S. Rajagopal, S. Abu-Surra, Z. Pi, and R. W. Heath, “Spatially sparse precoding in millimeter wave mimo systems,” *IEEE transactions on wireless communications*, vol. 13, no. 3, pp. 1499–1513, 2014.