

Parametrising Historical Chinese Courtyard-Dwellings: An Algorithmic Design Framework for the Digital Representation of Siheyuan Iterations Based on Traditional Design Principles

Abstract. Many Beijing Siheyuan, a type of Chinese vernacular housing with significant cultural value, have been lost in recent years. Preserving the few remaining has become a necessity, but many contemporary architects lack an understanding of their design principles. Based on a historical analysis deriving from Fengshui theory, the *Gongcheng Zuofa Zeli* ancient construction manual, and craftsmen's experience, this paper describes a parametric algorithm capable of producing Siheyuan variants within a 4D CAD environment which by transforming the original design principles into an algorithm contributes to an understanding of Siheyuan typology and their preservation. This algorithm was implemented in a virtual scripting environment to generate accurate virtual counterparts of historical or extant Siheyuan houses revealing the tacit computational rules underlying traditional Chinese architecture.

Keywords. Digital heritage; parametric design; Siheyuan; Fengshui; *Gongcheng Zuofa Zeli*; algorithmic design; computational design.

1. Introduction

Constrained by many traditional Chinese social and cultural factors, the form of Beijing Siheyuan embodies significant elements of Chinese culture. This paper employs an algorithmic approach to propose an interactive tool for parametrically generating Siheyuan variants based on its traditional design principles.

Today, the few Siheyuan houses that remain are facing oblivion. Being timber frame structures, they are particularly vulnerable to ageing and problems such as fire, humidity, and

pests. During the period 1949 to 2009, more than eighty per cent of Beijing Siheyuan were destroyed (Ni, 2009), to the extent that it has become hard to find good examples to study.

Not only are they vanishing but an understanding of their design is not being passed on to the new generation. Recent studies (Zhang, 2015; Li, 2016) highlight the problem of contemporary architects not understanding traditional Chinese tectonic principles and spatial qualities. Although both Chinese and international clients are willing to build and live in Siheyuan houses, most contemporary Siheyuan buildings can hardly be considered genuine, since features such as the proper proportions and symmetry are incorrect. The Beijing Cathay View Courtyard Residence project is a typical case of a 'fake' Siheyuan. A single villa of this project, as shown in Fig.1, is supposed to be designed in the traditional Beijing Siheyuan style, but it lacks an axial plan and has incorrectly proportioned rooms. This project might be said to lack the heart and soul of a real Siheyuan (Li, 2016), even though the developers claim that traditional architectural features recorded in *Gongcheng Zuofa Zeli (Structural Regulations, Qing Department of Qing Dynasty, 1733)* had been incorporated. It is no more a real Siheyuan than an English Tudor Ethan house of the late nineteenth century onwards is real Tudor.

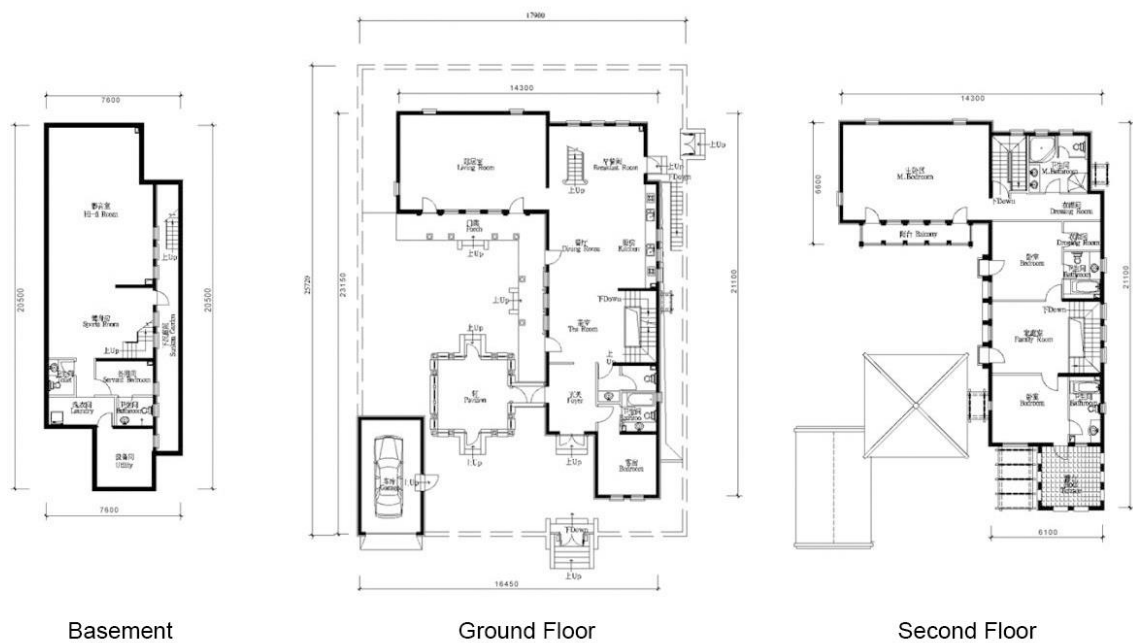

Fig 1. The rendering picture and floor plans of a showroom of The Beijing Courtyard Residence project.

Although there has been plenty of research on Siheyuan, the traditional design principles for generating Siheyuan variants have been little studied. Over the past decades, scholars such as Lu and Wang (1996, 2013), Ma (1999), Deng (2004), Chan and Xiong

(2007), Zhao (2013), and Zhang (2015) have dedicated themselves to understanding Chinese courtyard housing's cultural connotations as seen in the literature of history, most of which focused on its symbolism, beliefs, materials, and spaces using methods originating in the humanities.

More interesting for us, are the few researchers who have investigated traditional Chinese architecture using typological approaches, such as compositional analysis, shape grammar, and space syntax. Inspired by J.N.L Durand's simplified geometric scheme of classical architecture (Villari, 1987), Ni (2009) and Li (2010) respectively investigated Beijing Siheyuan's compositional rules by setting a set of criteria to categorize variants of Beijing Siheyuan examples. Their studies revealed the large variety of Siheyuan forms and proved the flexibility of its design principles, but perhaps failed to show the core principles to generate variants. Shape grammars have been developed for some Chinese traditional designs (Stiny, 1977, 2006). Stiny's followers such as Chiou and Krishnamurti (1995, 1996), presented the grammar of vernacular Taiwanese courtyard dwellings based on the traditional local design principles. By successfully presenting the generation of many house examples using shape grammar, their studies grasped the essence of vernacular Taiwanese courtyard housing's design principles using computational approaches. Li (2001) revealed the grammar of standard Chinese building types recorded in *Ying Zao Fa Shi* (Li, 1103). Xiong et al. (2013) investigated the grammar of Gulou, a wooden tower building type in south China, and implemented this grammar computationally. Huang et al. (2019) employed space syntax techniques to study Beijing Siheyuan's cultural connotations, which computationally explored spatial configuration of Chinese courtyard housing, but it focused on a

representative building example rather than varied individuals without considering how houses respond to different contexts. Moreover, Chiou and Krishnamurti (1997) investigated the computational consideration underlying Fengshui, a kind of Chinese geomancy, which constrains the design of Chinese courtyard housing. The algorithm presented in that study focused on building orientation and auspicious construction dates but overlooked the rules of site selection which in fact dominates the design of Siheyuan, as governed by Fengshui.

Rule-based approaches to architecture are old. Even *De Architectura* by Vitruvius (Murphy et al., 2013), can be seen as a rule-based description of classical architecture. Similarly, *A Pattern Language* by Christopher Alexander et al. (1977), lists architectural tropes that can be composed to shape buildings and communities. In recent years, parametric design techniques have been employed by architects to design ‘computationally generated complexities’ (Agkathidis, 2015). Scholars, on the other hand, have used the same idea to find the simple principles that underlie complexity. Brown and Steadman (1987) used Flemming’s “DIS” program (1987) to generate variants of three types of British housing plans based on a set of constraints shaping rooms composition, which revealed their history and social meaning. Duarte (2005) developed a recursive grammar for designing plans like those of Alvaro Siza’s houses at Malaguera leading to a program, that could generate 2816 variants in the “Siza style”. Liu and Wu (2015) produced a computer program to parametrically generate Beijing Siheyuan examples based on its constructional rules, however, as their focus was to study the modular system underlying ancient Chinese architecture, they did not display Siheyuan’s traditional design principles.

Studies like these have demonstrated the usefulness of computer-aided tools in architectural design. However, the software described here, such as *Shape Grammar Interpreter*, *DepthmapX*, is not widely used by architects in design practice, but only by academic researchers. On the other hand, although researchers such as Chiou and Krishnamurti (1997), Liu and Wu (2015) are developing their own software by using coding in C/C++ and Python programming languages, such approaches remain inaccessible for architects as they lack knowledge of such skills. *Grasshopper*, a visual scripting application (Tedeschi, 2011) embedded in *Rhinoceros* 3D modelling software, allows architects and students, with limited programming knowledge, to explore algorithmic design. Li (2016) used *Grasshopper* to parameterize the design rules in the ancient manual *Ying Zao Fa Shi* (Li, 1103), in order to clarify the details of Song dynasty buildings. Although her examination was limited to the examples recorded in the manual, she demonstrated that algorithms could integrate architectural design rules in a tool that could have a wider application.

Computational approaches offer a new way to access the literature and drawings of traditional Chinese designs that are otherwise difficult to understand. With this aim in view, we translated the design rules underlying Siheyuan design into a *Grasshopper* algorithm, an interface with which many architects are familiar. We then verified our tool by comparing the models it created to existing drawn examples, and thus, we hope to answer the following questions:

- Could we embed the tacit Siheyuan design rules in an algorithm?

- Could such an algorithm be used as an interactive tool for designing traditional Beijing Siheyuan houses and generating models?
- Could such a tool deal with traditional Siheyuan variants corresponding to the different contexts of a real-life project?

Two limitations of this work should be highlighted. First, we only focused on common Siheyuan types as they emerged in Beijing, thus rare cases such as parallel-grouped Siheyuan and Siheyuan with a garden have not been considered. Second, this paper focuses on the Siheyuan form down to the scale of the timber frame, we have not (yet) considered decorative details.

2. Materials and Methodology

2.1 Materials

Many forces, such as feudalism, Confucianism, Taoism, clans, cosmology, construction law, and geographic location, have shaped Siheyuan. Although the logic of these forces has been clarified in anthropology (Chan and Xiong, 2007), they do not necessarily account for significant differences between examples. In our view, the variation in Beijing Siheyuan is the result of Fengshui and construction rules, both explicit and implicit.

- Fengshui provides guidance to geomancers and craftsmen. Specifically, the “*Xing Shi* (observing context)” method helps householders select an auspicious site and the “*Li Qi* (regulating vital energy)” method based on the concept of “cosmic resonance” helps craftsmen and householders predict and select auspicious orientations, qualitative space, and appropriate dimensions of rooms.

- Chinese buildings were governed by construction laws, which imposed a modular system for the dimensions of building components. Beijing Siheyuan reached its peak during the Qing dynasty (1616-1912) and most remaining Siheyuan houses from this period follow the *Gongcheng Zuofa Zeli* compiled by the Qing government. As this work is linguistically difficult to understand, we used Liang's study *Qing Shi Yingzao Zeli (Qing Style Building Regulation, Liang, 2006c)*, which referred to *Gongcheng Zuofa Zeli* supplemented with interviews with craftsmen in order to describe the modular system. Although the government required householders to follow the construction law strictly, many house variants occurred, based on the experience of the old craftsmen passed from each generation to the next. This tradition provides tacit and unwritten codes underlying Siheyuan form.

2.2 Methodology

Beijing Siheyuan design principles were conventionally represented in text supplemented with drawings of prototypical examples on an ideal site that did not reflect the flexibility of Siheyuan design. All Siheyuan houses are variants of these ideal examples (Ni, 2009). We extracted the design principles using the previously named sources to clarify design procedures and parameters to make our algorithm. We then implemented the algorithm by using *Grasshopper* scripting components. The models we generated were then verified by comparing them with the corpus of historical examples. Over many iterations, we revised our algorithm to eliminate discrepancies between our models and the historical variants.

3. Developing the Siheyuan algorithm

3.1 Phase one: selecting a site

Once a householder has decided on a site, its suitability and potential are assessed by a section of Fengshui called “observing context”, which considers its shape and environment.

3.1.1 Site shape

Fengshui geomancers compare the length of edges on each side (north, south, east, and west) of the site. Although the Beijing grid had been mainly rectangular since the Song dynasty, some irregular polygon sites still existed. We found seven common site plan types, which are categorized as auspicious or ominous according to their shape (Fig 2).

In the algorithm, each edge of the site is measured and lengths compared. The closest corresponding pattern in Fig 2. is identified. This determines the fortune of the site. The generative process is as follows:

Identifying each edge of the site (length, location) → identifying site shape pattern → identifying shape fortune.

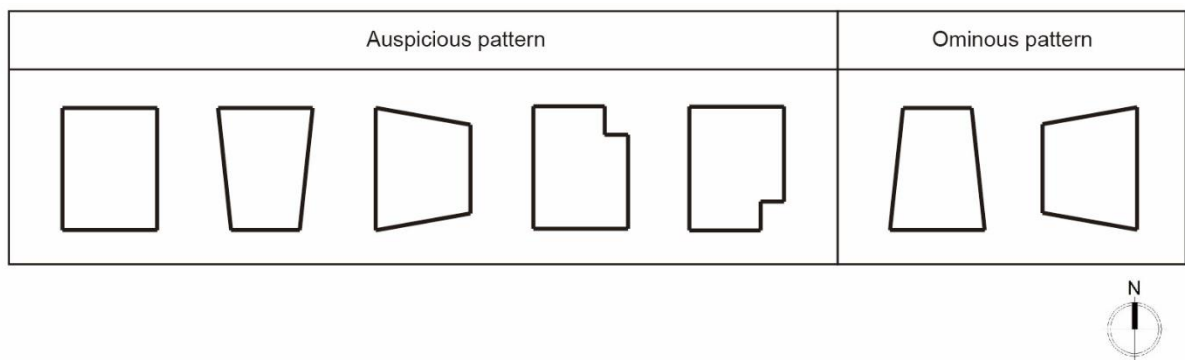

Fig. 2 Seven types of auspicious/ominous site shape patterns.

3.1.2 Site environment

Ancient geomancers looked for a relationship to local landmarks. The surrounding area was divided into octants (east; northeast; north; northwest; west; southwest; south; southeast, Fig

3). How far away landmarks could be to count as significant is uncertain. We assume that ancient geomancers defined this distance based on their own preference, rather than using a unified standard, and took this distance to be a parameter in our algorithm.

For Siheyuan in rural areas, geomancers considered five types of landmarks to be significant: the tree, the pond, the river, the hill or the mountain. In Beijing, some of these landmarks found their counterparts to urban objects, hills and mountains for instance, were analogized to surrounding buildings especially any tall and large buildings. Rivers were analogized to streets and alleys because rivers in Fengshui, in one aspect, are seen as symbols of circulation enabling the delivery of the necessities of life. However, although rivers, streets, and alleys all exist in Beijing city, it is noted, as mentioned by Yi et al. (1996) and Zhang (2009), that streets and alleys are defined as one type and rivers should be a different one, rather than categorizing all of them as one type in the assessment of the site. We guess the reason for this is that rivers could also be analogized to other objects, whose meanings may differ from circulation and it leads to significantly different results in site assessment. Therefore, the types of elements to be assessed for the Siheyuan design are the tree, the pond, the river, the street or the alley, the neighbouring building (or the hill or the mountain if present), and the street junction or the alley junction (Fig 3).

Geomancers also had to identify the comprehensive pattern of the site's environment (CPSE). In each octant, the existence or non-existence of each of the six types of landmarks was recorded. In Fengshui, the huge number of possible combinations fall into just three categories: auspicious, ominous, and non-auspicious and non-ominous. According to historical literature (Zhao, 2011), we counted 28 auspicious and 25 ominous patterns (Fig 3).

The other CPSEs are considered as non-auspicious and non-ominous. In practice, if the CPSE of a site is not auspicious, geomancers usually advise the householder to artificially reform the environment in order to make it auspicious. The exact site reformation process remains unknown, however, after the reformation having been completed, the site should fit within one of the 28 auspicious patterns, which is used for computation in our algorithm.

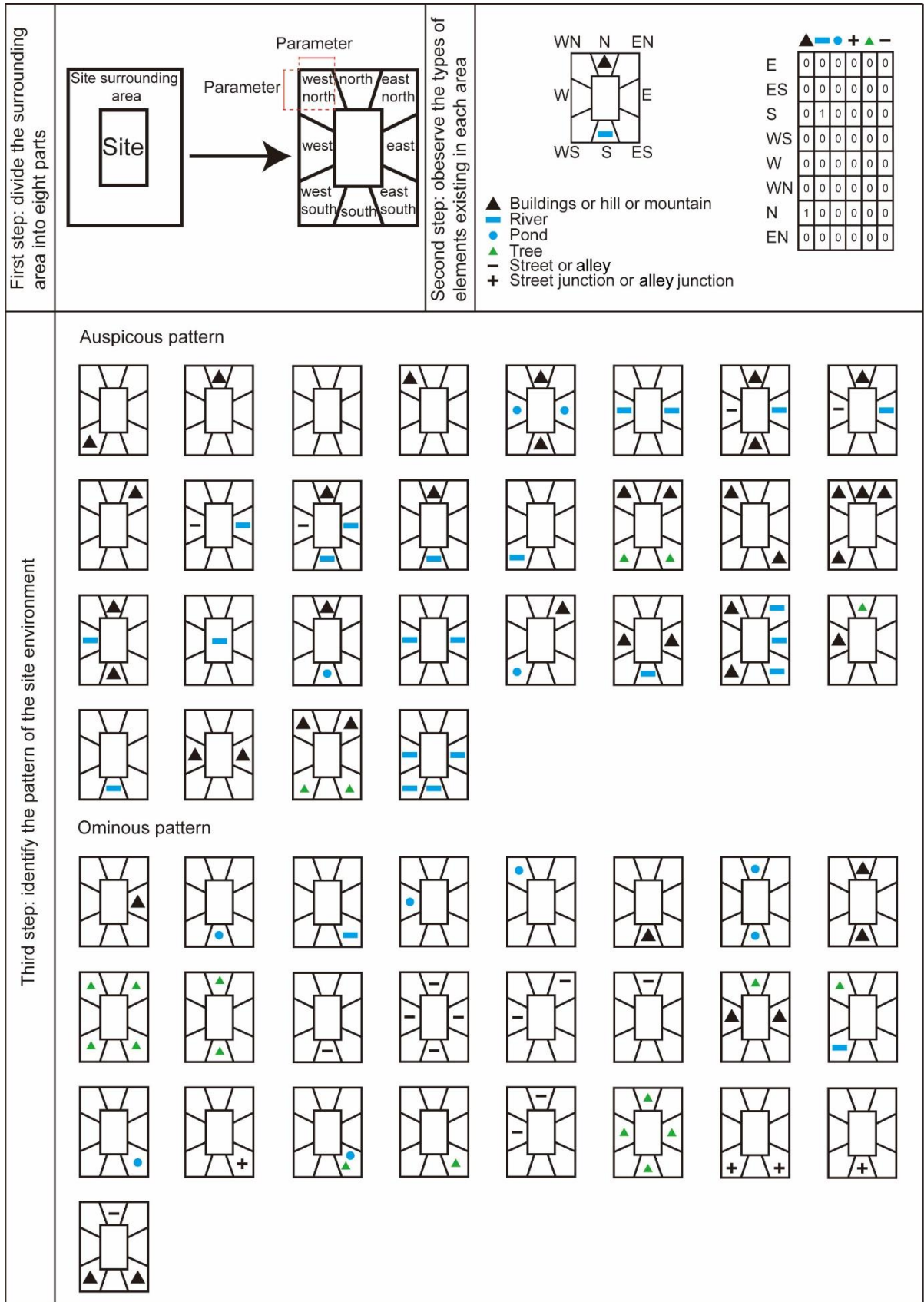

Fig. 3 Assessment process of the site environment to determine its fortune.

We encoded a site's CPSE as a binary string 48 characters long, representing the eight surrounding areas from east to northeast clockwise in blocks of six digits. In each block, each digit represents one type of the six environmental elements, 1 indicates existing, otherwise 0. We identified the 53 codes in representing the auspicious or ominous CPSEs. Meanwhile, to simplify the computation, for the non-rectangular sites, an outer rectangle of the site plan is generated by our algorithm and assumed as the site for the computation in this step.

3.1.3 Site size

Another factor that defines the quality of a site is its size. By observing the historical Beijing map, *Qianlong Jingcheng Quantu* (*Qianlong Capital Map*, 1748-1750), it is noted that the range of sizes of an available site for Siheyuan construction is broad, depending on the number of courtyards it contains. When describing the word 'courtyard' in Siheyuan context, it usually means the outdoor space enclosed by walls, which includes the open courtyard space and all the buildings surrounding that space. In many cases, some parts of the 'courtyard' are not completely enclosed by walls, instead, the rear boundary of a building is extended to define the boundary of a courtyard. In olden times the determination of the proper size of a Siheyuan was affected by the household's budget, social status, living demands, personal preference, and so on. To simplify, the value of the proper site size is set as an inputting parameter $S_{desired\ size}$ in this algorithm, which is decided by the householder's circumstances. A criterion, $D_{site\ size}$, represented as a numeric value, to evaluate the degree of the size difference between the actual site and the one desired by the

householder is set. The D value is defined by calculating the absolute size difference per cent to the desired one, whose equation is shown below.

$$D_{site\ size} = \frac{|S_{desired\ size} - S_{actual\ size}|}{S_{(desired\ size)}}$$

Although this factor doesn't influence the fortune of Siheyuan, it is an important factor taken into account in real projects.

In the algorithm, the three factors were given numeric values. For the site shape and the site environment, the criterion is its fortune, entered as 1 if auspicious or as -1 if ominous. For the site size, it is important to identify the size of the difference between the desired site and the actual site, the smaller the difference the more likely the householder is to proceed. Therefore, the larger the value of the $D_{site\ size}$ is, the less the possibility for the site to be selected. We assume the householder would tend to select a site when the value of the $D_{site\ size}$ is smaller than 0.2. The site size parameter value is given as 1 when $D_{site\ size} < 0.2$, -1 otherwise. The relative importance of the three criteria depended on geomancers' preferences, thus we added weighting to these values, so it could be set by users. The comprehensive assessment is defined by the summation of the three weighted values: the higher the result value, $A_{assessment}$, the fitter the site.

$$\begin{aligned} A_{assessment} &= f(C_{site\ shape}, C_{site\ environment}, C_{site\ size}, W_{site\ shape}, W_{site\ environment}, W_{site\ size}) \\ &= C_{site\ shape}W_{site\ shape} + C_{site\ environment}W_{site\ environment} + C_{site\ size}W_{site\ size} \end{aligned}$$

In many practical situations, where householders had more than one site to choose from, geomancers could compare them by using this assessment method. We have integrated this formula into our algorithm to find the most suitable site. The algorithm compares the results

of the iterative solutions of different sites using the same values of the parameters, such as $S_{desired\ size}$, $W_{site\ shape}$, $W_{site\ environment}$, $W_{site\ size}$, and the distance from the site edge to the surrounding area's outside boundary, which can be initially inputted by the users. It then indicates the site with the highest $A_{assessment}$ value. Each of the parameters in this phase affects the assessment result, but the weighting ratio between the three above aspects is the most significant one, which is freely decided by users. The value of the parameter corresponding to the range of influence of local landmarks, the distance from the site edge to the surrounding area's outside boundary, is usually around the width of the site. The value of another parameter, the householder desired site size, should be within a reasonable range (up to 2800 m²), which was the size range of Siheyuan according to Duan's survey (2016).

3.2 Phase two: designing the floor plan pattern

Once the site had been selected, craftsmen would design the floor plan pattern taking into account the householder's preferences, his budget, and status, incorporating the correctly sized rooms, walls, verandas, front gates, back gate, and festooned gate. According to traditional principles, we divided this process into four stages: defining the central axis, defining location pattern of the front gate and back gate, dividing the site into courtyards, and determining the floor plan pattern of each courtyard. Previous studies on the traditional design principles by Lu and Wang (1996, 2013), Ma (1999), Zhao (2013) were used to derive the rules. However, in practice, the plan pattern of each courtyard seems to have been flexible and there is no direct historical material to explain its principles, or anything to be found in these studies. Additionally, we examined plans of extant Siheyuan by Duan (2016),

survey data by Ni (2009), and referred to Li's (2010) studies on the *Qianlong* Capital Map to inform our constraints.

3.2.1 Defining the site's central axis

The site's central axis is a key parameter, not only are many components aligned to it, but it also determines the orientation of the primary room (*Zheng Fang*, in the form of an individual building, is the core space of a courtyard, and for Siheyuan with multiple courtyards, there is a most important primary room (MIPR), which is thought as the core space of the Siheyuan). To define the site's central axis, the geomancer had to determine a key point (which is the central point of the MIPR's floor plan) on the site by observing the underground soil texture to find the proper area to construct the MIPR which then created the central axis crossing the key point. We simplified the orientation of the central axis into two principles. The first, and more significant principle fixes the MIPR's front elevation according to the site orientation and its access to the outer urban fabric. Since the orientation of the central axis is the same as the orientation of the MIPR's front elevation, this principle forces the site central axis to be south-north or east-west. In fact, it was traditional in a north-south oriented site, to make the central axis, as well as the MIPR's front elevation, seven degrees anti-clockwise off the south. A site longer in the east-west oriented direction will have an east-west central axis. If its main access to the urban fabric is on the east edge, the MIPR's front elevation will also be to the east, and if it is on the west edge, the orientation of the MIPR's front elevation is west. The second principle requires the MIPR's front elevation to face natural water elements such as a river or a lake but have its back to any hill or mountain.

To transfer these rules into our algorithm, we employed the force vector algorithm. We created the algorithm to identify the actual site orientation and the main access to the urban fabric that detects the accessible urban space adjacent to the site, thus determining the MIPR's front elevation. To simulate the three patterns shaped by site orientation and urban fabric in the first principle, we set three vectors on the key point correspondingly: one vector to seven degrees contra-clockwise off the south-oriented, one east oriented, and one west oriented, and created the corresponding algorithm to decide the selection of the application of the vector determined by identifying site orientation and urban fabric. To simulate the natural elements' effect in the second principle, we set two types of vectors. One derives from the key point to the geometrical centre of a river or a lake on plan, while the other from the geometrical centre of a hill or a mountain to the key point. For each natural element, the force vector can be calculated that is inverse proportional to the distance of the natural element from the key point, which is based on detecting the location of these elements surrounding the site. The MIPR's orientation is the vectorial calculation of the forces on the key point from the three vector types. As the first principle is much more influential than the second, we have assigned a weight ratio between the vector derived from the first principle and from the second principle as a parameter (*A: B: C*) to enable the site orientation and urban fabric vector larger than the other two. The vectorial calculation follows the below formula:

$$\begin{aligned}
 & \overrightarrow{F(\textit{orientation})} = A \\
 & \overrightarrow{F(\textit{site orientation and urban fabric})} + B \overrightarrow{F(\textit{water's attractive line force})} + \\
 & C \overrightarrow{F(\textit{hill or mountain's repulsive point force})}
 \end{aligned}$$

The location of the key point, set by the user, is represented by a coordinate point (x, y) on a two-dimensional plane where the site plan is positioned, whose value is constrained by the requirement that the key point is located within the site plan. The surrounding area defined for considerable natural elements is determined by a square plan with two hundred metres long sides, whose centre point is positioned on the geometrical centre of the site. The surrounding natural elements and the location of the key point affect the orientation of the MIPR, but their effects are slighter than the site orientation and the site outer urban fabric, which is pre-decided by site context. Therefore, the orientation of the site's central axis is always parallel to, or few degrees off the site orientation. The orientation of the MIPR's front elevation and the central axis can be generated using our algorithm (See the example in Fig 4).

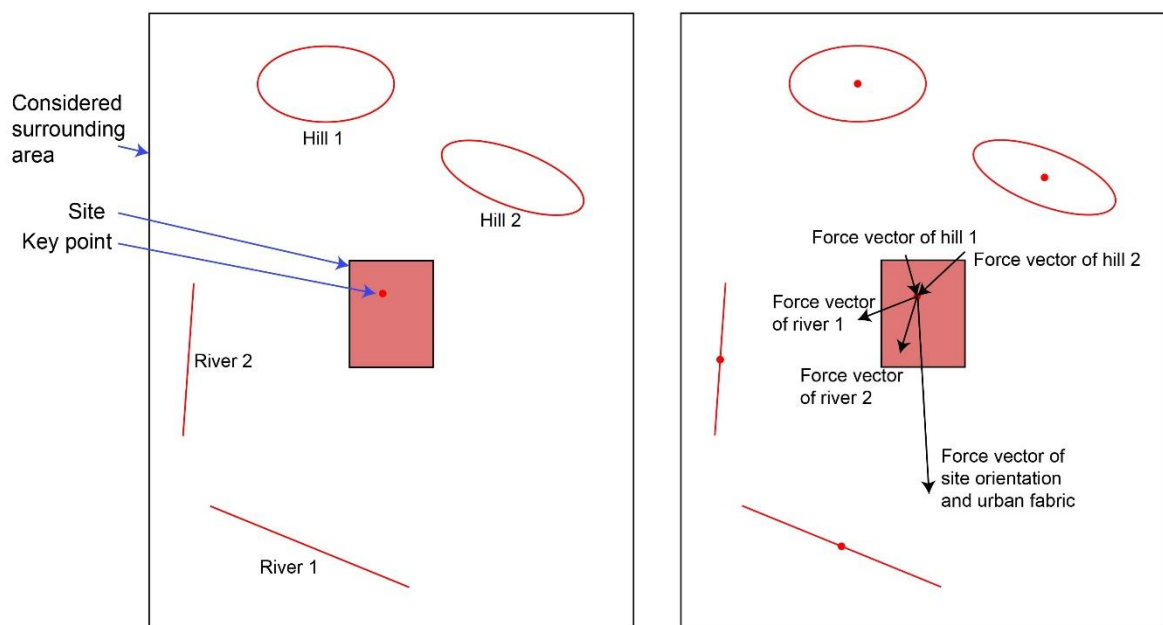

Fig. 4 An example of generating the central axis using force vectors based on the two defining principles.

3.2.2 Defining the location pattern of the front and back gates

The location of the gates is defined by two factors: the site's orientation and the neighbourhood's context. First, the site's orientation is categorized into two types: east-west oriented, or north-south oriented. Second, for the neighbourhood's context, we identify the adjacent area on the four sides of the site's rectangle by observing if it is occupied by neighbouring buildings or accessible urban spaces, such as streets or alleys. The two parameters comprehensively determine the front gate's location as shown in Fig 5:

For a south-north oriented site, there are three patterns:

- First pattern: when a street or an alley is on the south of the site, the gate is located at, or close to the east end of the south side of a Siheyuan.
- Second pattern: when there is a street or alley on the east or west of the site but not on the south, the gate is located at, or close by, the southern end of the boundary between the street and the site.
- Third pattern: if a street or an alley can only be found on the north, the gate is to be located at, or close to the end of the north edge. Remarkably, in Siheyuan with multiple courtyards it is common for a north-south corridor to allow for a gate at the south end of the site, so the circulation starts with the courtyard on the south. See the two-courtyard example in Fig 6.

For an east-west oriented site, there are two patterns:

- First pattern: when there is a street or an alley next to the east or west of the site, the front gate is located at, or close to the south end or north end of the boundary to the street.

- Second pattern: when there is no street or alley to the east or west but only to the north or the south, the front gate is located at the east end (when primary rooms face east) or the west end (when primary rooms face west) of the boundary to the street.

Siheyuan houses with a back gate are rare. The back gate is usually located at, or close to, the end of an edge of the last courtyard, where it enables the circulation connecting from the Siheyuan interior to the exterior space. Usually, the front gate and the back gate cannot be located on the same edge of a Siheyuan.

Accordingly, in our algorithm, the identification of available pattern(s) is fixed by the two factors: the site's orientation and the neighbourhood's context, of which both are predetermined upon site selection. This process is as follows:

Identifying site context (site orientation, neighbourhood context) → identifying available gate location pattern (s).

We produced the algorithm to identify the site context by defining four areas (east, south, west, north) adjacent to the site and then detecting whether any street or alley was existing in each area. Based on this identification and the determination of site orientation, the algorithm to give then gives the pattern of the front gate and back gate. Since the back gate is infrequent, a parameter for users to decide if it exists is defined. Since the locations of a gate given in Fig 5 are rough, and it is noted that gates were moved and rotated slightly on the edges of Siheyuan in many cases, one parameter is defined to enable users to slightly move and rotate to gates on the plan.

south-north oriented site	first pattern		
	second pattern		
	third pattern	<p>one courtyard</p>	<p>multiple courtyards</p>
east-west oriented site	first pattern		
	second pattern	<p>MIPR east oriented</p>	<p>MIPR west oriented</p>



h: Hutong alley or street n: neighbor building

Fig. 5 Patterns of front gate location

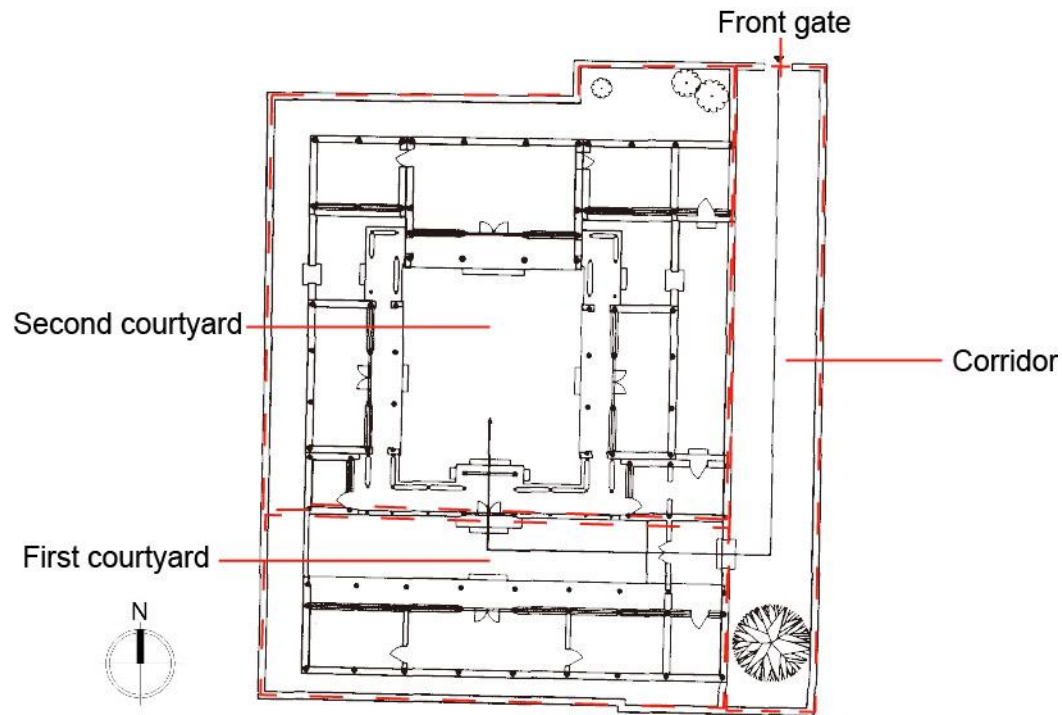

Fig. 6 A two-courtyards Siheyuan with a south-north oriented corridor connecting the front gate to the south courtyard (after Ma, 1999).

3.2.3 Dividing the site into courtyards

For most Siheyuan housings, the courtyards lie on the site in a row, and consequently, the sum of edges of all courtyards of a Siheyuan are the edges of the actual site and the boundaries of each two adjacent courtyards. In most cases, a boundary of two adjacent courtyards is a segment, whose orientation is perpendicular to the site orientation.

Two constraints shape the division of a site: the site size, and the ratio between width and depth of each courtyard. The site size was constrained by the urban grid system of Beijing, which consequently fixed the number of courtyards in Siheyuan, most commonly between one and five. According to Ni's (2009) statistic measuring survey data on historical Siheyuan examples, we inferred the relationship between the site area of a Siheyuan and its number of courtyards (Table 1).

Number of courtyard	1	2	3	4	5
Area(m ²)	100-400	300-800	500-1200	1000-1900	1700-2800

Table. 1 Number of courtyards in relation to Siheyuan sizes.

Another division constraint is the ratio between the width and depth of each courtyard. Normally Beijing Siheyuan sites are rectangular, or nearly rectangular, and courtyards are in the row along the site orientation, consequently, the courtyards it contains are, or close to rectangular as well. For a non-rectangular site, we use the outer rectangle of the site plan for computation. The size of a courtyard contains two parameters: the dimension parallel to the short edges of the site, called courtyard width, and the dimension parallel to the long side, called courtyard depth. The width of each courtyard is easy to be identified by measuring the actual site, as it is the same with its short edges. However, the dimension of each courtyard depth varies. It is noted that once the site width and the ratio between the width and depth of each courtyard are identified, the courtyard depth can be determined. Since both a site and its courtyards are rectangles, and the site area is pre-determined once a site is selected, and the site width and courtyard width are pre-determined as the same, each courtyard's size and location could be identified once the number of courtyards and each courtyard's depth has been decided.

Based on the above analysis, we defined two types of parameters: the number of courtyards ($X_{courtyard\ number}$) and the ratio between the width and depth of each courtyard (X_{ratio}). The first parameter is constrained by the area of the site, as illustrated in Table 1. The second one is a set of numbers ($X_{ratio\ 1}, X_{ratio\ 2}, \dots, X_{ratio\ N}$). Since the site and its courtyards are rectangles, the sum of all (X_{ratio})s is a pre-determined value linked to the site

selection. This relationship constrains both values of the two parameters. The value range of each ratio between the width and depth of each courtyard is constrained by the type of the courtyard (standard, non-standard). As shown in Fig 7, courtyards in the middle are standard courtyards, while courtyards at the front or back can be either standard courtyard or non-standard courtyard. The ratio (X_{ratio}) between the width and depth of a standard courtyard is $X_{ratio} \leq 0.5$, and the one of a non-standard courtyard is $X_{ratio} > 0.5$. The two types of parameters interactively affect the plan form of each courtyard. The formula indicating the relationship between the two parameters is set, as shown below, in which both the $L_{site\ depth}$ and $L_{site\ width}$ are pre-determined value once a site is selected and the $X_{courtyard\ number}$ and X_{ratio} are variables inputted by users.

$$L_{site\ depth} = \sum_{N=1}^{X_{courtyard\ number}} X_{ratio\ N} \times L_{site\ width}$$

To divide a site into courtyards, the algorithm operates in the following steps:

Defining site area, site width, and site depth → defining the available number of courtyards
 → determining the number of courtyards → determining of the depth of each courtyard.

Three examples of dividing the same site into courtyards with different values of the number of courtyards ($X_{courtyard\ number}$) and the ratio between the width and depth of each courtyard (X_{ratio}) are shown in Fig 8.

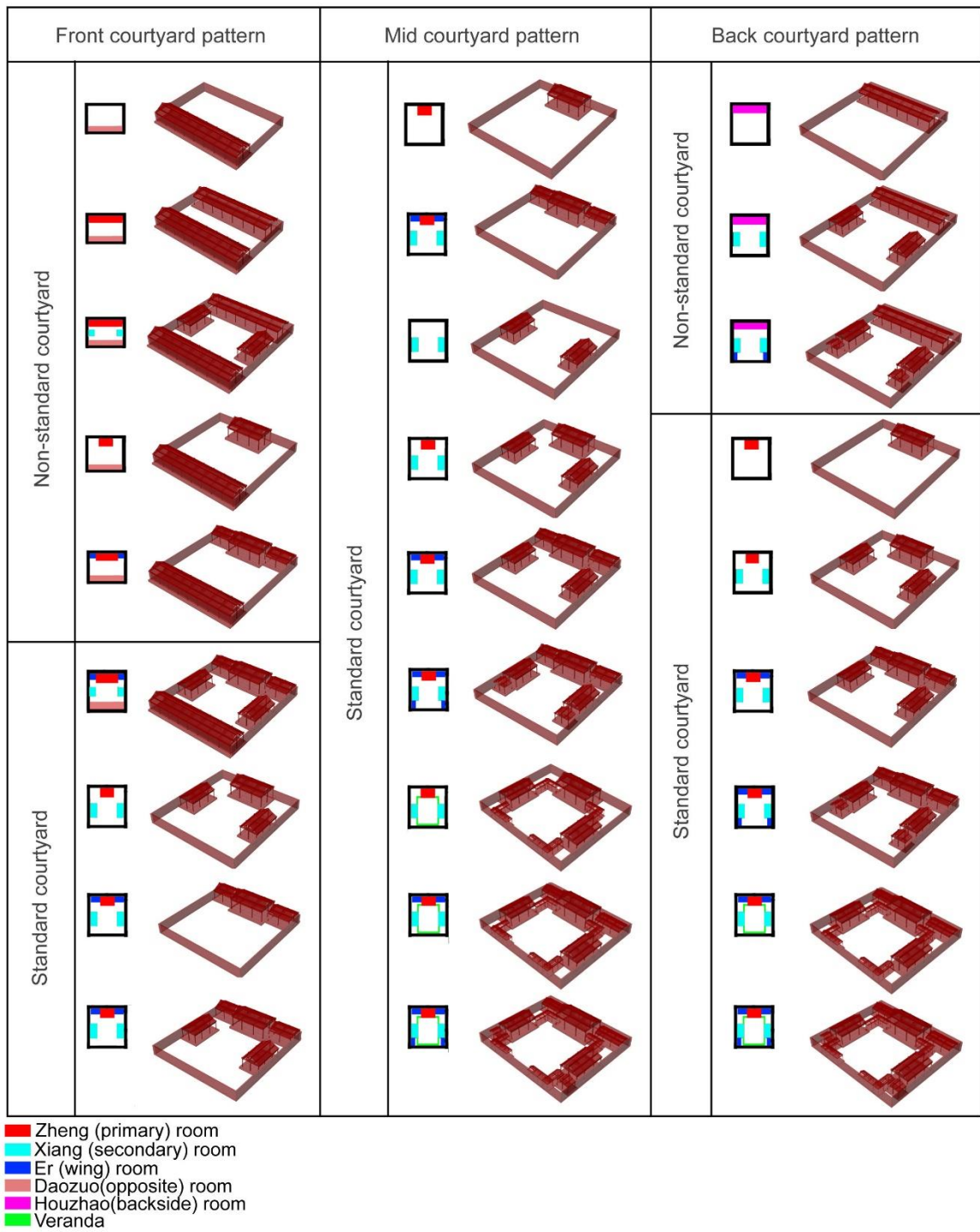

Fig. 7 Floor plan patterns categorized by location of the courtyard (at the front, middle, or rear), and type of the courtyard (standard or non-standard).

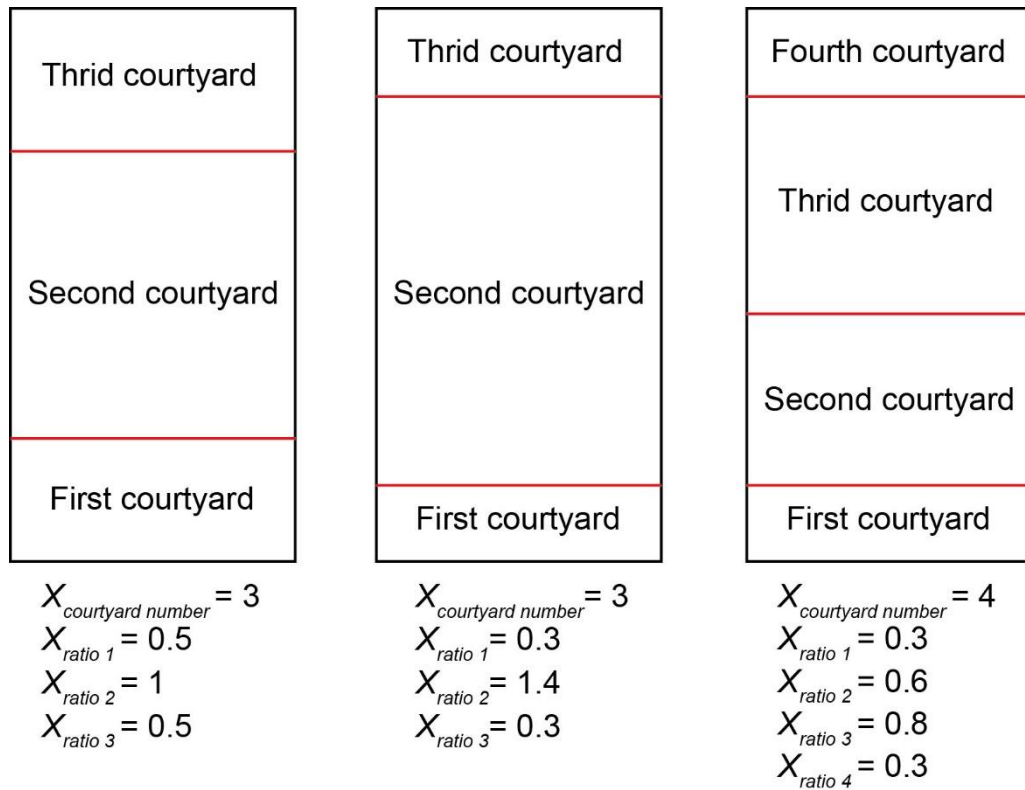

Fig. 8 An example of dividing a site into courtyards with different values of the number of courtyards ($X_{courtyard\ number}$) and the ratio between the width and depth of each courtyard

$$(X_{ratio})$$

3.2.4 Determining the floor plan pattern of each courtyard

As previously mentioned, there is no historical evidence for any rules concerning the floor plans of courtyards, therefore, we investigated the relevant statistical and historical studies to categorize floor plan pattern types based on two criteria: location of the courtyard (at the front, middle, or rear of the Siheyuan), and type of the courtyard (standard or non-standard). The floor plan patterns of standard courtyard could contain any components of the veranda, the primary room, the east secondary room (*Dong Xiang Fang*), the west secondary room (*Xi Xiang Fang*), the east wing room (*Dong Er Fang*), the west wing room (*Xi Er Fang*), the east secondary wing room (*Dong Xiang Er Fang*), the west secondary wing room (*Xi Xiang Er Fang*), the festoon gate (*Chuihua Men*, usually only in the first mid courtyard),

and the floor plan patterns of the non-standard courtyard must contain the opposite rooms (*Dao Zuo Fang*) or the backside rooms (*Hou Zhao Fang*) and may have some other components the same with standard courtyard or not. There must be a front gate in the front courtyard and maybe a back gate in the back courtyard (or a corridor connecting the gate and the front courtyard). A non-standard courtyard at the front must contain the opposite rooms. If a non-standard courtyard is located at the back, besides its back gate, it must contain the backside rooms. We have categorized the common floor plan patterns by courtyard location and courtyard type (Fig 7).

Meanwhile, another tacit rule derived from Confucianism requires that in each courtyard, the primary room is generally located at the middle of the backside edge on the plan with the courtyard's central axis crossing its floor plan centre, and most other components such as wing rooms, secondary rooms, secondary wing rooms, and verandas, are pairwise axisymmetric about the courtyard's central axis. For the courtyard where the MIPR is located, the courtyard axis is the same as the site central axis. For the other courtyards, the way of determining the courtyard central axis is not being described in historical materials. According to our observation on extant Siheyuan examples, we inferred it is defined to be parallel to the site central axis and crossing the primary room of the courtyard or the midpoint of the boundary between the courtyard and the adjacent rear courtyard (when the courtyard does not contain a primary room). Since the orientation of the site central axis is parallel to, or a few degrees off the site orientation, the location of rooms and verandas shown in Fig 7 could be slightly moved and rotated when the site central axis is not parallel to the site orientation.

In this step, our algorithm identifies the location and type of each courtyard, which have been decided in the previous step, and also enables users to decide the type of each courtyard if applicable. Finally, users can choose from one of the available floor plan patterns. After the location and type are determined, the algorithm can correspondingly move the location and rotate the orientation of individual rooms and verandas, as they are illustrated in Fig 7. In our algorithm, we defined the location of the central point of the floor plan of each room and verandas with a two-dimensional coordinate on the plane where the site plan is positioned. The movement of each room and verandas is defined as a line vector and their rotation is measured in degrees. The algorithm of movement and rotation enables the primary room crossing the courtyard central axis and other individual rooms and verandas generally pairwise axisymmetric about the courtyard central axis. Therefore, the values of the line vector and the rotation degree are determined by the location of the courtyard central axis. The generation process is the following:

Defining courtyard location → deciding courtyard type → identifying available floor plan patterns → deciding the floor plan pattern → moving and rotating each room and verandas

3.3 Phase three: designing the individual architectural components

The main types of architectural components that may exist in a Siheyuan are the veranda, the primary room, the secondary room, the wing room, the secondary wing room, the opposite room, the backside room, the festoon gate, the front gate, the back gate, and the edge wall.

Once the floor plan pattern is determined, craftsmen design them using rules from *Gongcheng Zuofa Zeli* and Fengshui, adjusted according to their experience. Liang's findings (Liang, 2006c) from his *Gongheng Zuofa Zeli* study were used to derive the rules

constraining these components. In parallel to this, a section of Fengshui called “regulating vital energy (*Li Qi*)” method and other ancient social forces, such as Confucianism and ancient clans, fixed their dimensional relationship.

3.3.1 Individual buildings

Aside from the festoon gate, veranda, and edge wall, the rooms in a Siheyuan, and the gates were constructed as individual buildings without any structural connection between them.

The most important components of these buildings are the carpentry structural frame and podium, the design of which was based on a modular method recorded in *Gongcheng Zuofa Zeli*, which results in similar forms that differ only in terms of scale, orientation, and exquisiteness of craftsmanship.

Normally an individual building has a rectangular plan composed of rows of columns. The space between two neighbouring columns is called a bay (*Jian*), with many rafters in each bay (See three examples in Fig 9.). The four corners of each bay could be occupied by a column. For convenience, it is assumed that there is a column on every corner point when calculating the height of an individual building, although it never happens in practice. In fact, as shown in Fig 9, there are three variations of the vertical side section of individual buildings corresponding to three types of the layout of columns: a) when the number of columns in the vertical side section view is 7, columns exist on the first and second outmost rows of the bay corner points on the long side of the building plan and the middlemost row’s outmost points; b) when the number of columns in the vertical side section view is 6, the columns exist on the first and second outmost rows on the front side, the outmost rows on the rear side, and the fourth row’s outmost points on the front side; c) when

the number of columns in the vertical side section view is 5, columns exist on the outmost rows on the long side and the middlemost row's outmost points. The outmost columns on the front in the vertical side section view are called eave columns (*Yan Zhu*). It is noted that, on the plan of an individual building, the length of the carpentry structural frame in the front view, called 'building width', is the sum of all lengths of bays in the front view. Similarly, its length in the side view, called 'building depth', is the sum of all lengths of horizontal projections of rafters (See Fig 9.). The ratio between lengths of bays in the front view varies, but the lengths of horizontal projections of the rafters are the same. According to *Gongcheng Zuofa Zeli*, the important parameters are the number of bays in the front view, the number of rafters in the side view, and the diameter of an eave column. The value of the three parameters varies, depending on the type of the room. The available values of the first two parameters are constrained by the type of the room, as shown in Table 2. The value of the diameter of an eave column is the basic unit to calculate dimensions of other components. This value should not exceed the size of the available timber. It is noted that the height of an eave column equals the length of the middlemost bay(s) in the front view multiplied by 0.8, and the length of the rest of the bays, from the middlemost to the outmost, are pairwise symmetrical around the middlemost bay(s). In practice, craftsmen would decide the building width first, and then calculate the diameter of the eave columns based on the ratio between lengths of bays in the front view, the number of bays in the front view, and the ratio of an eave column's diameter to its height. Once the diameter of the eave column is obtained, the length of the horizontal projection of a rafter and the building depth could also be calculated based on the number of rafters in the side view, and the ratio of an eave column's diameter to

the length of horizontal projections of a rafter in the vertical side section view. The building width and building depth are constrained by the rule that the individual building has to be smaller than the courtyard it is located in. By using a calculation method, called "raising truss method (*Ju Jia*)", the heights of the other columns are determined. There are three types of compositions of columns of individual buildings in the vertical side section view. The "raising truss method" gives ratios from the length of horizontal projections of rafters to the height difference of two adjacent columns in the vertical side section view, as shown in Fig 9.

	Primary room	Secondary room	Primary wing room	Secondary wing room	Opposite room	Backside room
Number of bays x number of rafters	3x4	3x4	1x4	1x4	1x4	3x4
	3x5	3x5	2x4		2x4	4x4
	3x6		0.5x4		3x4	5x4
	5x6				4x4	6x4
					5x4	7x4
					6x4	8x4
						9x4

Table 2. Common values combinations of the number of bays in front view and the number of rafters in flank view

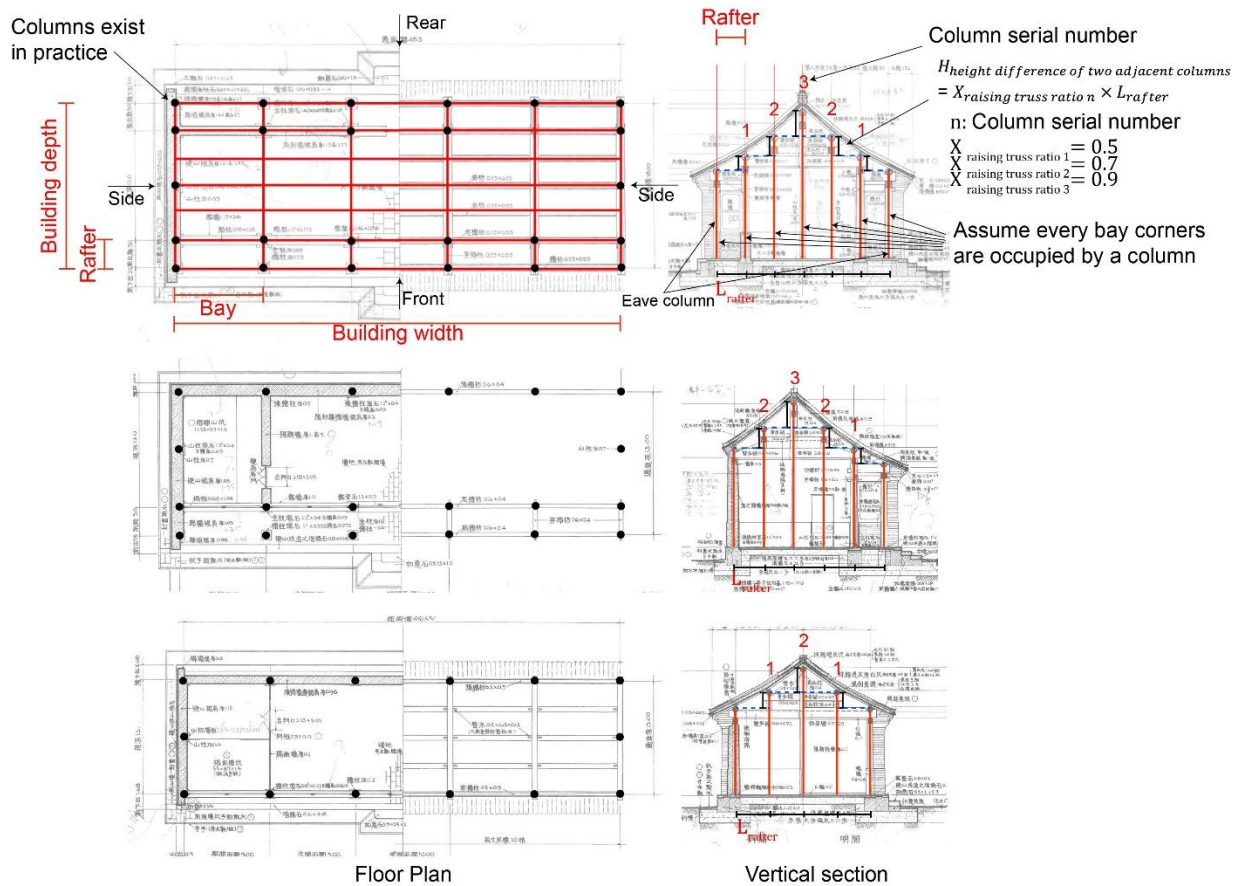
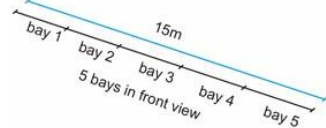

Fig 9. Three examples of individual rooms corresponding to three types of vertical side sections (after Liang, 2006b)

In later checks, we found out that the dimensions of the individual buildings generated by our algorithm based on Liang's work are inconsistent with the historical ones. By re-studying *Gongcheng Zuofa Zeli*, we noted that the differences are caused by the fact that the values of some constants in calculation formulas in Liang's *Qing Shi Yingzao Zeli* are different from the original ones underlying *Gongcheng Zuofa Zeli*. We note that these values were flexibly decided by craftsmen in practice rather than by strictly following rules from *Gongcheng Zuofa Zeli*. These values also shape the dimensions of individual buildings. The most influential two are the ratio between lengths of bays in front view and the ratio of an eave column's diameter to its height.

Based on the above analysis, the algorithmic logics to define the geometrical dimensions of an individual building and the height and location of each column are clarified. They depend on five parameters: the building width, the number of bays in the front view, the number of bays in the side view, the ratio between the length of bays in the front view, and the ratio of an eave column's height to the length of the horizontal projection of a rafter in the vertical side section view, all of which are set as parameters in our algorithm. The algorithmic process to generate an individual building example is shown in Fig 10. The dimensions and positions of the remaining components of a building's structural frame are mathematically determined by the five parameters. The calculation of the sizes of the structural carpentry components and the podium is illustrated in Table 3, and the compositional relationships of these components are demonstrated in Fig 11 by an example of individual building, from which their positions are explicated. The numbers in Fig 11 correspond to the numbers in table 3, which are the different structural components. Eighteen variations with different values of the five parameters are shown in Fig 12.

Step 1: define bays in front view.



Parameter inputted by users:

number of bays in front view: $X_{bay\ number} = 5$

ratio between lengths of bays in front view:

$X_{ratio\ bay\ 1} : X_{ratio\ bay\ 2} : X_{ratio\ bay\ 3} : X_{ratio\ bay\ 4} : X_{ratio\ bay\ 5}$
 $= 0.8:0.9:1:0.9:0.8$ (the middlemost bay length is set as the unit)

building width: $X_{width} = 17.6m$

Formula:

$$X_{width} = \sum_{n=1}^{X_{bay\ number}} X_{ratio\ bay\ n} \times L_{middlemost\ bay}$$

$$L_{middlemost\ bay} = H_{eave\ column}$$

Calculation result:

height of eave columns: $H_{eave\ column} = 4m$

length of the middlemost bay in front view: $L_{middlemost\ bay} = 4m$

Step 3 define columns in vertical side section view.

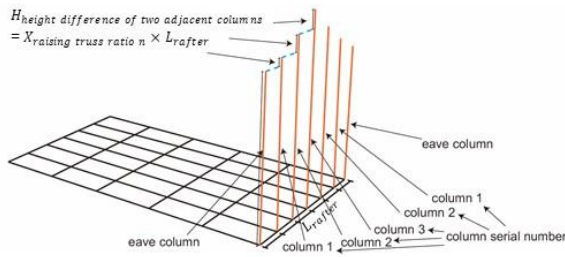

Formula:

$$H_{column\ n} = \sum_{n=1}^{X_{column\ serial\ number}} X_{raising\ truss\ ratio\ n} \times L_{rafter} + H_{eave\ column}$$

$$X_{raising\ truss\ ratio\ 1} = 0.5 \quad X_{raising\ truss\ ratio\ 2} = 0.7 \quad X_{raising\ truss\ ratio\ 3} = 0.9$$

Calculation result:

Height of each column: $H_{column\ 1} = H_{column\ 5} = 4.8m$, $H_{column\ 2} = H_{column\ 4} = 5.92m$, $H_{column\ 3} = 7.36m$

Step 2: define rafters in side view.

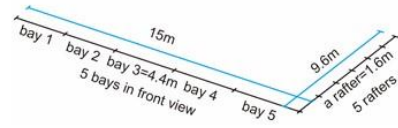

Parameter inputted by users:

number of rafters in side view: $X_{rafter} = 6$

ratio of an eave column's height to the length of horizontal projection of a rafter in vertical side section: $X_{ratio\ column\ to\ rafter} = 0.4$

Formula:

$$L_{rafter} = H_{eave\ column} \times X_{ratio\ column\ to\ rafter}$$

$$X_{depth} = \sum_{n=1}^{X_{rafter\ number}} L_{rafter}$$

Calculation result:

length of horizontal projections of a rafter in vertical side section: $L_{rafter} = 1.6m$

building depth: $X_{depth} = 9.6m$

Result: room height, depth, width, and all column locations, heights are derived.

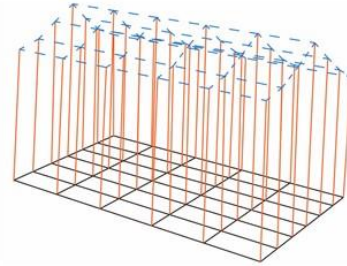

Fig 10. The algorithmic process to generate an individual building example. (Units in metres)

	name	code	translation	width	height	depth	diameter
column	eave column	1	yanzhu檐柱		11D or 8/10 width of the central bay width		D
	gold column	2	jinzhu金柱		raising truss method		D+1
	mountain column	3	shanzhu山柱		raising truss method		D+2
beam	embracing head beam	4	baotouliang抱头梁	4~5D+1/10D	1.4D or 1.5D	1.1D or D+1 or 1.2D	
	five frame beam	5	wujialiang五架梁	length of middlemost two bays in flanked view+2D	1.5D	1.2D or D+2	
	three frame beam	6	sanjialiang三架梁	length of middlemost two bays in flanked view+2D	1.25D	0.95D	
fang (tie beam)	crossing fang	7	chuanchafang穿插枋	4~5D+2D	D	0.8D	
	eave fang	8	yanfang檐枋	width of room	D	0.8D	
	down gold fang	9	jinfang金枋	width of room	D or 0.8D or D-2	0.8D or 0.65D or 4/5D-2	
	up gold fang	10	shangjinfang上金枋				
	ridge fang	11	jifang脊枋	width of room	0.8D	0.65D	
purlin	eave purlin	12	yanlin檐檩	width of room			D or 0.9D
	down gold purlin	13	shangjinlin上金檩	width of room			D or 0.9D
	up gold purlin	14	xiajinlin下金檩	width of room			D or 0.9D
	ridge purlin	15	jilin脊檩	width of room			D or 0.9D
underboarding panel and short column	eave underboarding panel	16	yandianban檐垫板	width of room	0.8D	0.25D	
	down gold underboarding panel	17	shangjindianban上金垫板	width of room	0.65D	0.25D	
	up gold underboarding panel	18	xiajindianban下金垫板	width of room	0.65D	0.25D	
	ridge underboard panel	19	jidianban脊垫板	width of room	0.65D	0.25D	
	gold short column	20	jinguazhu金瓜柱	D	distance between five frame beam and three frame beam	D	
	ridge short column	21	jiguazhu脊瓜柱	D-0.8D	distance between three frame beam and ridge purlin	D	
rafter, connecting eave, roof boarding panel, tile edging	circle rafter	22	yuanchuan圆椽			distance between eave purlin and down gold purlin (in oblique direction)	1/3D
	square rafter	23	fangchuan方椽	1/3D	1/3D or 3/10D	distance between eave purlin and down gold purlin (in oblique direction)	
	flying rafter	24	feichuan飞椽	1/3D	1/3D or 3/10D	up extension method	
	flower frame rafter	25	huajiachuan花架椽	1/3D	1/3D	distance between the top point of down gold purlin and the top point of up gold purlin (in oblique direction)	
	brain rafter	26	naochuan脑椽	1/3D	1/3D	distance between the top point of up gold purlin and the top point of ridge purlin (in oblique direction)	
	big connecting eave	27	dalianchuan大连椽	width of room	0.4D or 3/10D	1/3D or 3/10D	
	small connecting eave	28	xiaolianchuan小连椽	width of room	1/3D or 3/10D	3/10D	
podium	base floor	29	tajitai基		2.2D		
	hard moutain base extension	30	yingshanchushan硬山出山	1.8 D+ 3.6			

Table 3. Mathematical calculation of dimensions of components of structural carpentry and podium (Units: in cuns).

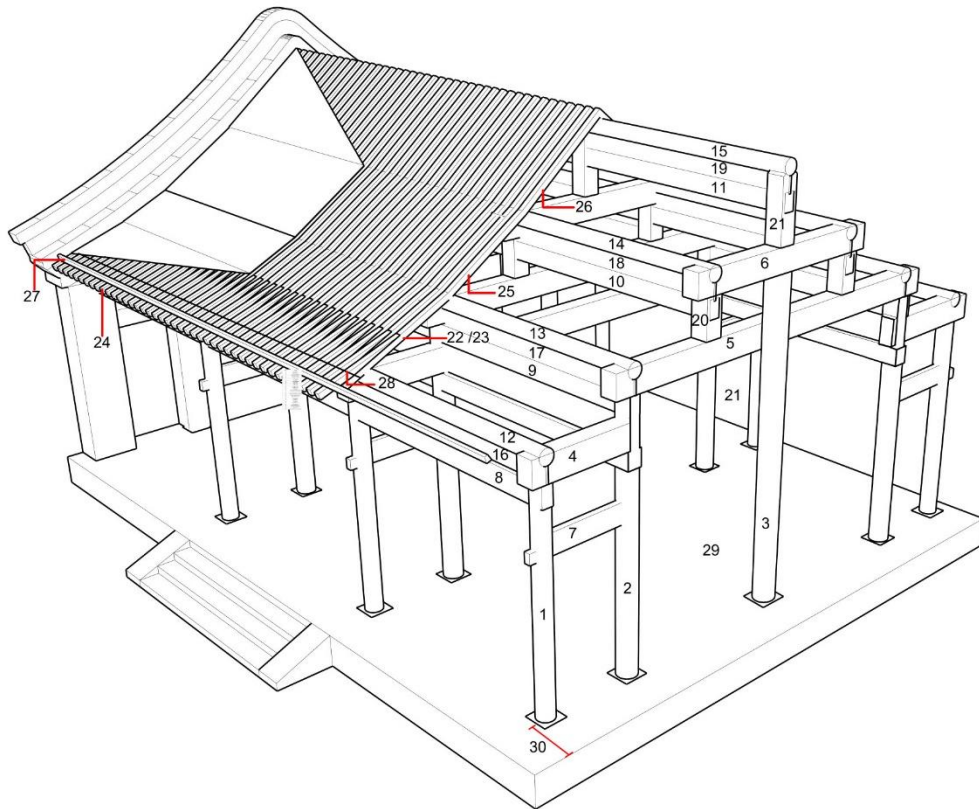

Fig. 11 Relationship of an individual building's components' positions.

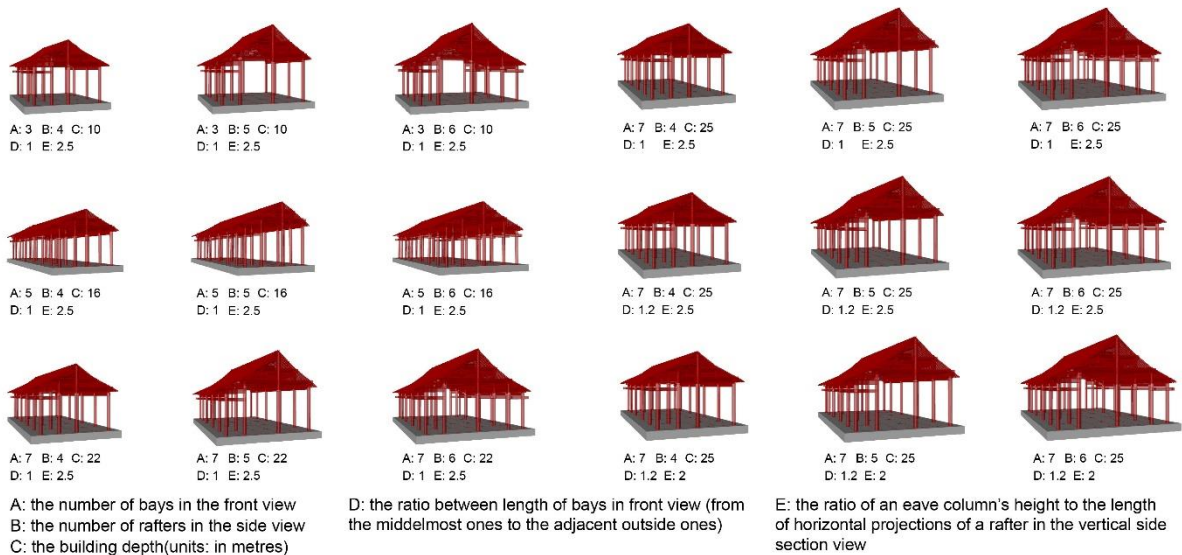
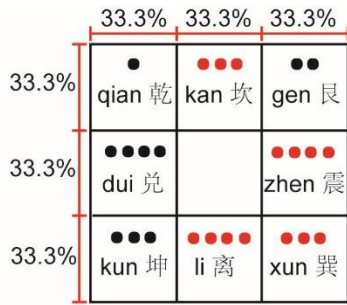

Fig. 12 Eighteen variations of the individual building with different values of five parameters

What is the order of sizes of rooms? Supplementary to the seven parameters two rules were used. The first, influenced by Confucianism and ancient clans, requires a hierarchy of rooms. One way to embody this is to make rooms follow a sequence from large to small such

as primary room > secondary rooms > wing rooms > secondary wing rooms. Second, in the “regulating vital energy” method of Fengshui, there is a rule predicting the householder’s fortune by defining auspicious areas and ominous areas of a courtyard, called *ba gua qi zheng da you nian* (eight trigrams seven politics big tour calendar). This rule divides a courtyard into nine areas with different degrees of fortune for each area. We transformed this rule into an algorithm, whose parameter is the householder’s birthday. We noted there are eight patterns of the results indicating the fortune of each area, which constrain scale relationships between the individual buildings in a courtyard. The constraint is that the most auspicious part of the site is used for the largest individual building and so in ranking order, and vice-versa for the ominous spaces. Therefore, the eight patterns of fortune are eight patterns of sequences of the scale of individual buildings in a courtyard (Fig 13). The constraint derived from Confucianism and ancient clans is much more influential than the other one from Fengshui. Therefore, when the two rules conflict, the Confucian rule takes precedence.



Origin of fortune: qian 乾

Room scale in areas from large to small :
 dui>kun>gen>qian>kan=xun>=zhen>li

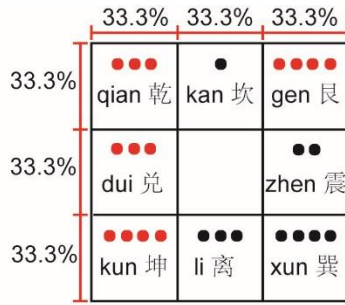

Origin of fortune: kan 坎

Room scale in areas from large to small:
 xun>li>zhen>kan>qian=dui>gen=kun

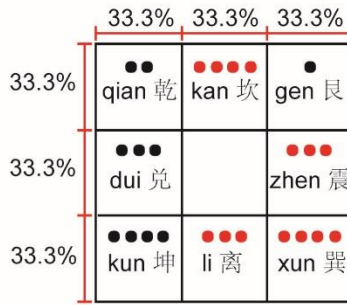

Origin of fortune: gen 艮

Room scale in areas from large to small:
 kun>dui>qian>gen>zhen=li>xun=kan

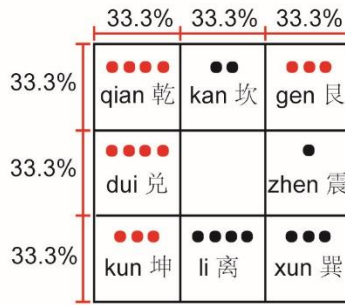

Origin of fortune: zhen 震

Room scale in areas from large to small:
 li>xun>kan>zhen>kun=gen>dui=qian

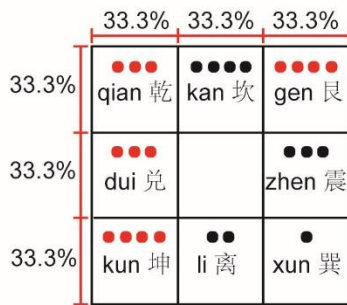

Origin of fortune: xun 巽

Room scale in areas from large to small :
 kan> zhen>li>xun>dui=qian>gen=kun

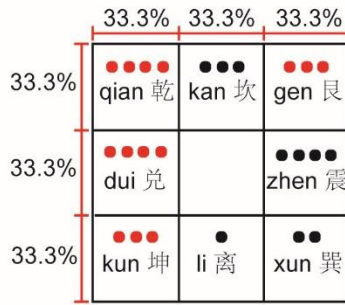

Origin of fortune: li 离

Room scale in areas from large to small:
 zhen>kan>xun>li>kun=gen>qian=dui

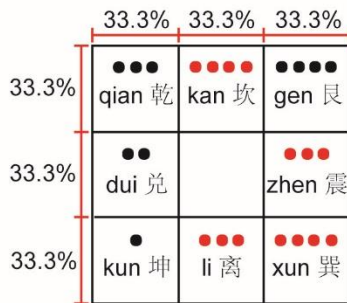

Origin of fortune: kun 坤

Room scale in areas from large to small:
 gen>qian>dui>kun>li=zhen>kan=xun

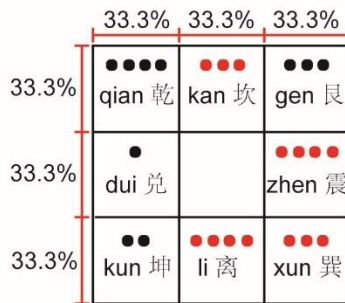

Origin of fortune: dui 兑

Room scale in areas from large to small:
 qian>gen>kun>dui>kan=xun>li=zhen

- Ominous area
- Auspicious area

The number of dot indicates the degree of the fortune



Fig. 13 Eight patterns of determining the fortune of each area in a courtyard.

The design principles of individual buildings were transformed into an algorithm directly. The complete algorithm uses six input-parameters from the *Gongcheng Zuofa Zeli*, plus two constraints governing the size hierarchy of the parts. Additionally, for Fengshui related version, the householder's birth year is set as a parameter to obtain the constraint of the individual buildings' scale relationship.

3.3.2 Veranda

One obvious feature distinguishing a veranda from other parts of the buildings is its curved rooftop. For the most part, however, an algorithm for verandas, based on the modular system to determine the size and location of components is similar to that for individual buildings. However, rather than an individual building shaped by the seven parameters, a veranda is fixed by two factors. The first is the location of the primary room and secondary rooms of the courtyard where the veranda is placed. These are fixed by determination of courtyard size in the second phase and of users' preferences in the fourth phase. The second is the side length of a veranda column in plan view, whose value is chosen by craftsmen between 4.8 and 6 cuns. In our algorithm, the locations of these rooms are measured once these parameters are inputted, and, for simplification, the side length is defined as a constant in the value of 6 cuns.

3.3.3 Gates

There are two gate types: the front/back gate and festoon gates. Constructed as individual buildings, the form of front gates and back gates is similar to rooms. The difference is that a gate doesn't have an enclosed partition for defining the interior, but a single partition defining the outside and inside of a Siheyuan. This partition is usually a wall containing a

door. The design principles of the structural carpentry frame of the gates and individual buildings are the same, whose differences are the available value of parameters. For the gates, the value of the number of bays in the front view and of the number of rafters in the vertical side section view is set as 1 and 5 respectively. The principles of festoon gates are different and will be the subject of further research.

3.3.4 Edge wall

The form of the wall is not parametrically constrained but is defined by the division of the courtyard edge. Wall usually exists on the edge of each courtyard, but in many cases, some parts of the courtyard edge are occupied by buildings so no wall is needed. The wall's form can vary in detail, and in our cases, for convenience, we assume it is in a cuboid. The thickness of the wall is usually between 11 and 16 cuns and the height between 70-120 cuns. For convenience, our algorithm set them as constant values, 11 and 90 cuns respectively.

3.4 Phase four: relocating architectural components

Although the location of each architectural component is fixed once each courtyard's floor pattern is decided, we note that in some Siheyuan examples supplied by Duan (2016) and recorded on the *Qianlong* Capital Map individual rooms and verandas are additionally moved or rotated. They are located freely within the courtyard but generally pairwise axisymmetric about the central axis. It is noted that in these cases the courtyard axis does not correspondingly change even if the primary room moves in this phase. Similar to the algorithm in the step of determining the floor plan pattern of each courtyard, we define the location of the central point of the floor plan of each individual room and verandas in a two-dimensional coordinate (x, y coordinate axis) on the plane where the site plan is positioned. The movement of each individual room and verandas is defined as a function of a line vector

represented by variable x, y . The distance and direction of the movement are represented by the values of x and y , which is defined as a parameter and its values range is constrained that the movement limits the individual rooms and verandas to be within the plan of the courtyard. The rotation of each individual room and veranda is defined as a parameter measured in degrees, which positions the room or veranda rotated clockwise. According to our observation of built Siheyuan examples, the rotation is small. Therefore, the value of the degree is defined between -20° and $+20^\circ$.

3.5 The algorithm's structure/ design framework

The parametric logic attenuates Siheyuan design to just twenty-four types of parameter. The workflow (Fig 14) shows the algorithm in *Grasshopper*, enabling users to generate a Siheyuan by inputting these parameters.

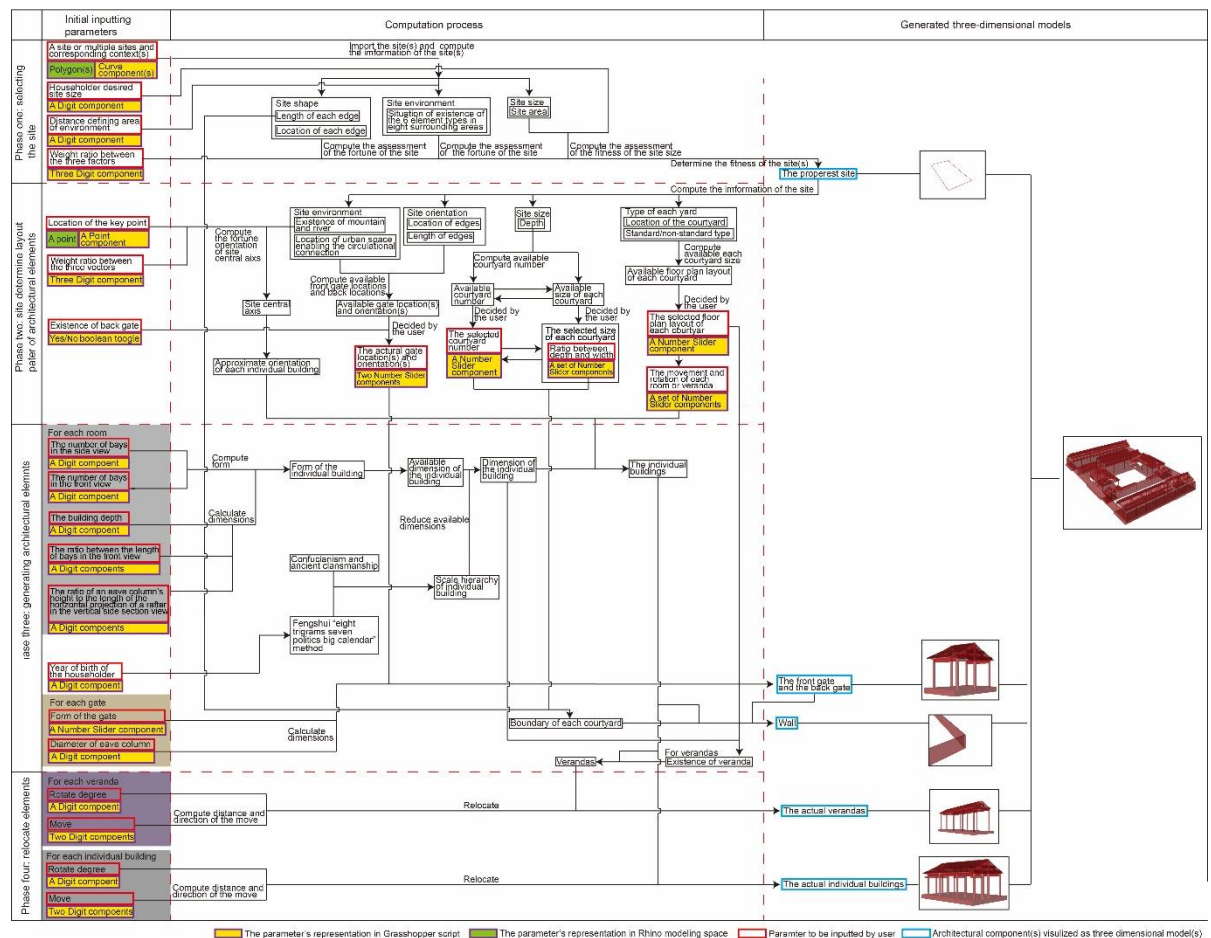

Fig. 14 Flow chart of the design framework.

4. Verifying the algorithm

To verify our Siheyuan algorithm, we generated models by setting the same parameters' values in our tool as the ones observed in historical examples and then comparing the results with reality. Due to the difficulty in collecting information from a complete Siheyuan, the comparison is conducted using data of different Siheyuan fragments from different sources. In particular, we examined the fortune of 24 representative site examples given by Yi et al. (1996), to see if they followed the “observing context” method in Fengshui to assess their fortune. Since our produced results are the same as their assessment, our site selection algorithm is confirmed.

To verify the floor plan pattern, we collected Siheyuan plans from Duan's measured survey (2016) and Ma's work (1999). We then applied our algorithm to re-produce the same floor plan patterns. We have successfully re-produced a typical three-courtyard Siheyuan, as presented by Ma (1999). However, we have noted there are some floor plan patterns that cannot be created by our tool, as evident in the example given by Ma (1999) (Fig 15), whose orientation of each courtyard central axis varies from each other, resulting in a pathological composition of architectural components.

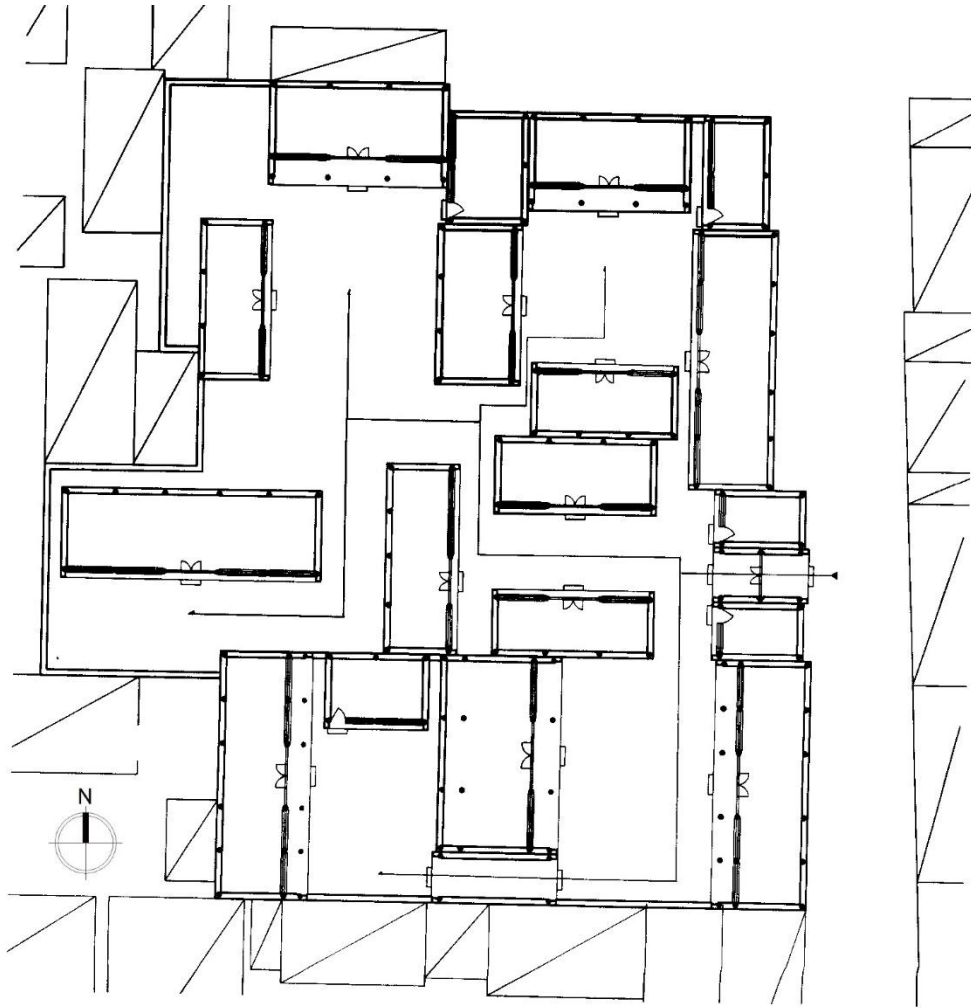

Fig. 15 An abnormal and inauspicious Siheyuan example that cannot be generated by our tool (after Ma, 1999).

We note that it is impossible to verify the room-scale relationship, since the essential data for historical Siheyuan examples, such as the householder's birth year, are not recorded. However, according to our observation of plans of extant examples, the constraint deriving from Confucianism and ancient clans are inferred to be much more influential than the one from Fengshui, which embodies on obvious differences between room scales. Therefore, in this study, we ignored the Fengshui constraint.

To verify whether the algorithm produced valid architectural components or not is challenging because most Siheyuan components existing today are badly damaged or

reconstructions of original buildings built after the Qing dynasty, and measuring materials about historical examples are very few and limited in detail. Alternatively, we examined architectural components from Liang's drawings (Liang, 2006b), which contains detailed component dimensions. Liang produced the drawings referring to the *Gongcheng Zuofa Zelite* and interviews with the successors of ancient craftsmen. Consequently, the buildings in his drawings are believed to be following the rules of the Qing dynasty. To verify this, we compared the structural component dimensions produced by our tool with their counterparts on Liang's drawings. The two versions are consistent. (For example, a building drawn by Liang is selected to derive values of parameters and used to generate the counterpart by our tool. The two examples were overlapped to observe, as shown in Fig 16.). By controlling the seven parameters for each room, it could be ensured that the relationship of scales of the generated rooms in a courtyard stratifies the constraint from Confucianism and ancient clans.

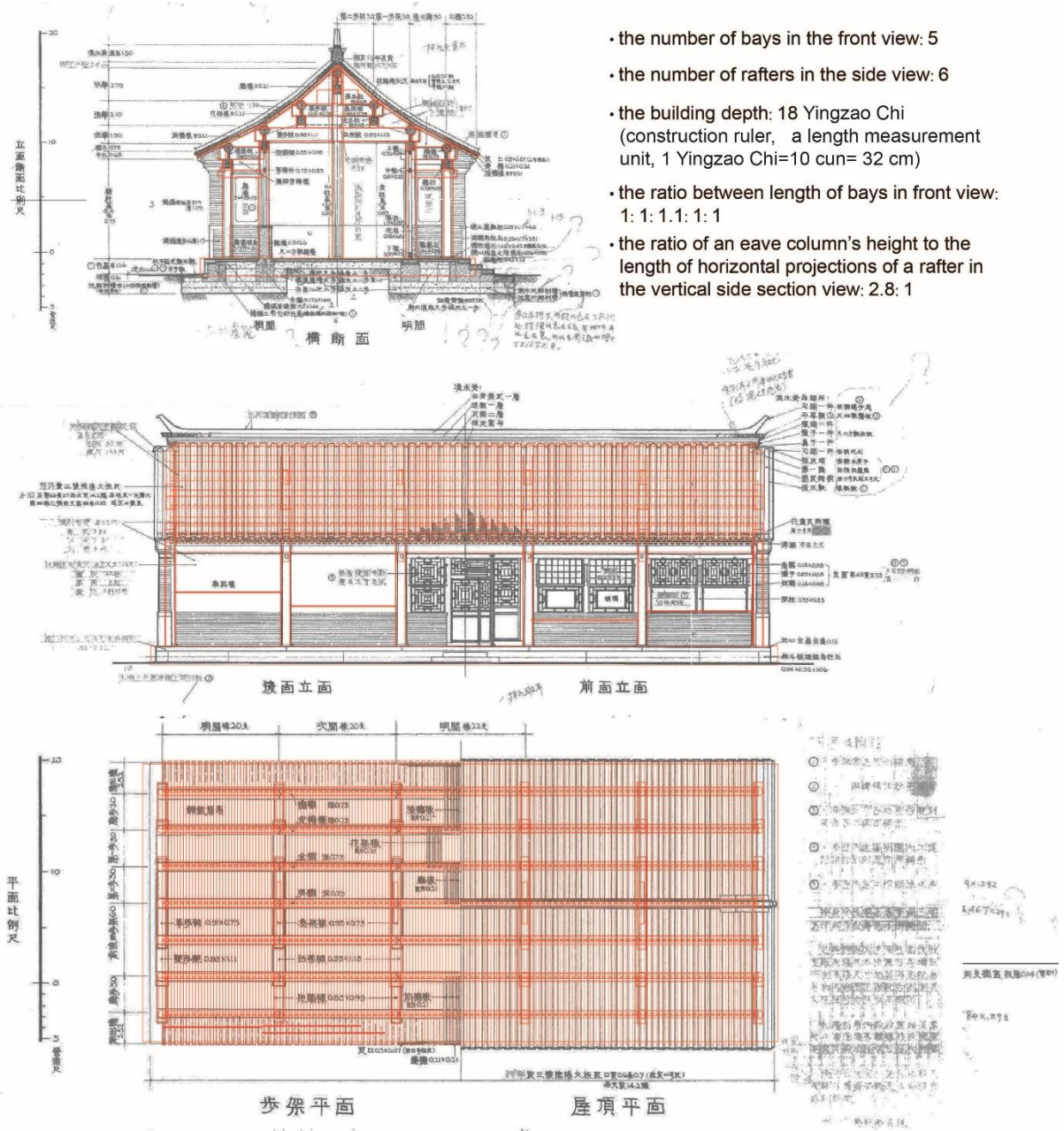

Fig. 16 The comparison of an individual building of Siheyuan represented by Liang (2006b) and the corresponding example generated by our tool, overlapped in red colour.

Despite the discrepancy between Liang's study (Liang, 2006c) and our algorithm on the four parameters, we successfully generated many Siheyuan houses. Some of Duan's plan drawings (2016) from his measuring survey on extant Siheyuan and corresponding models generated by our tool in top view have been overlapped, thus we can test potential discrepancies (See two examples in Fig 17). Evidently, our tool can reproduce Siheyuan

housings with high accuracy, if compared to drawings, photos, and text in Duan's measuring survey. However, it has to be noted, that these drawings lack detailed dimensional data, and consequently, we cannot verify our tool in terms of its ability to reproduce the architectural components in every detail.

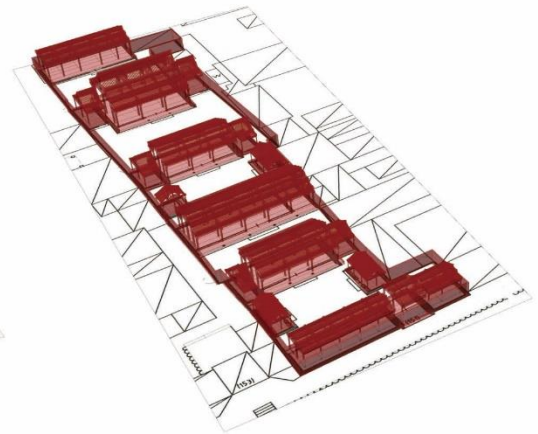
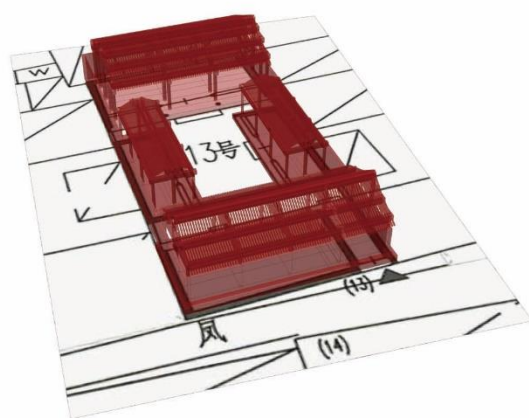
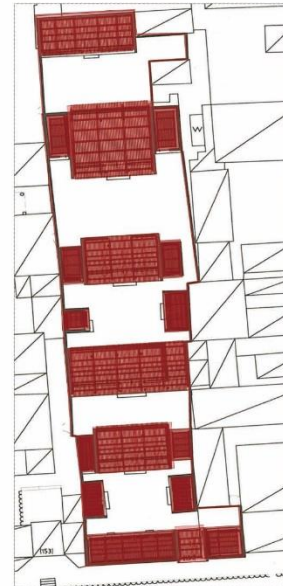
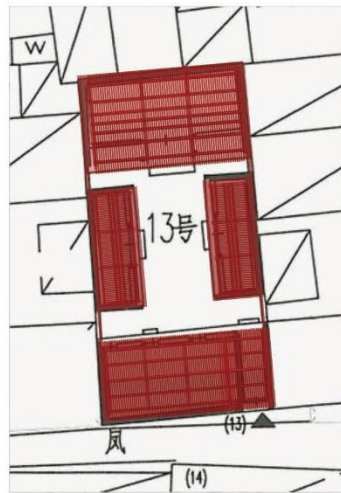
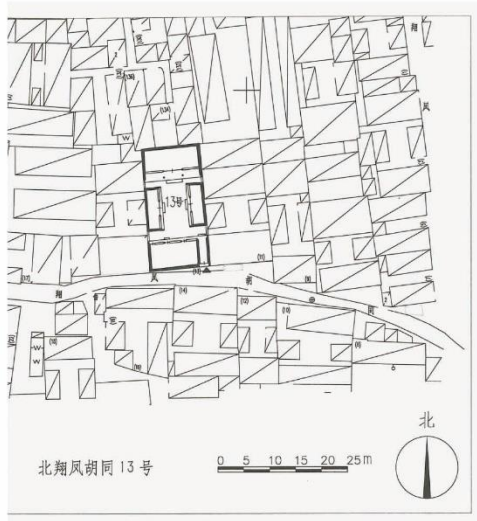

Fig. 17 Two comparisons of algorithmically generated Siheyuan overlapped with Duan's survey on extant examples (2016).

5. Conclusions

With this research, the tacit design rules have been revealed and transformed into an algorithm in coherence with the Fengshui, *Gongcheng Zuofa Zeli*, and the craftsmen's experience. The proposed algorithmic tool proved capable of producing Siheyuan types with high accuracy, which replicate key features of traditional Siheyuan since we successfully verified it by producing examples consistent with examples given by other scholars.

Siheyuan, the most common dwelling type of Beijing during the Qing dynasty, is much sought after today. Previously, to design a Siheyuan, architects needed to follow the design principles to determine locations and dimensions of each component by complicated computing and calculating manually, however, using this tool, they just need to input the required parameters and the three-dimensional representations will be created automatically. Compared with the conventional method of design and modelling, our tool takes only a few seconds to generate models by inputting parameters. The formulated algorithm is easy to use and saves time to design models and modify Siheyuan, thus it will be useful for today's architects who wish to work in the Siheyuan idiom.

The discrepancy between Liang's study (Liang, 2006c) and our algorithm on the four constants resulted in the inconsistencies of the size of individual buildings and its carpentry structural frame and podium. We noted, using the values of the four constants given by Liang, that the algorithm can neither generate the buildings recorded in Liang's drawings (Liang, 2006b) nor the extant Siheyuan examples with the same sizes. This discrepancy is caused by two factors. First, it is possible that Liang mistakenly recorded these constant, since we found self-contradiction in his studies. Liang has published two books (Liang,

2006b, 2006c) introducing design principles of architecture of the Qing dynasty. One explains the design principles using text and photos, including the calculation of dimensions of construction components in the form of a pithy formula, and the other illustrates these principles by developing architectural drawings of building and construction component examples complete with dimensions. We have noted that these dimensions of components on the drawings of *Qing Gongbu Gongcheng Zuofa Zeli Tujie* (Liang, 2006b) are not consistent with the calculation of them in *Qing Shi Yingzao Zeli* (Liang, 2006c). Therefore, as Liang (2006a) stated, “over the past decade I have found many mistakes”, his data are not entirely reliable, despite the fact that both books are widely accepted by scholars. Second, by studying built Siheyuan examples, we found that these values varied case by case. Consequently, even if we apply the original values of these constants in *Gongcheng Zuofa Zeli* to our algorithm, it is impossible to correctly generate counterparts of every built Siheyuan. It is noted by many scholars (Ma, 1999; Zhao, 2013; Lu and Wang, 2013) that Siheyuan, as the most common dwellings in Beijing constructed by residents rather than official buildings constructed by the government, did not strictly follow the rules from *Gongcheng Zuofa Zeli*. We speculate that craftsmen, who used formulas to pass the design principles from each generation to the next based on their individual experience rather than the rulebook, changed the values of some constants. Nevertheless, by parameterising these constants, we still can use this tool to generate Siheyuan designs the same with extant examples that emerged in Duan’s (2016), Ma’s (1999), and Ni’s (2009) studies once we obtain the necessary inputting parameters. While we are alert to the possibility that there might be more tacit rules than we are aware of, we view these pathological cases as

illuminating the normal: since the shapes of these sites are usually irregular and many other uncertain factors are shaping the results, craftsmen often improvised but always tried to be as close as possible to what would occur with no constraint, so that even in irregular circumstances something approximating an ideal form was produced. This explains the common view that Siheyuan is based on some ideal models.

We noted that the rules for Siheyuan are a way of controlling the standard of buildings, and those rules were applied more rigorously in Beijing than further afield in China. The fact that an algorithmic model of a house is even possible is a reflection of an attempt to control houses by means of rules, which is then reflected in their typology.

References

- Agkathidis, A., 2015, Generative Design Methods - Implementing Computational Techniques in Undergraduate Architectural Education. In *Proceedings of the 33rd Europe Computer Aided Architectural Design* 47-55.
- Alexander, C., Ishikawa, S., & Silverstein, M., 1977. *A pattern language: Towns, buildings, construction*. New York: Oxford University Press.
- Brown, F., & Steadman, J., 1987. The analysis and interpretation of small house plans: some contemporary examples. *Environment and Planning B: Planning and Design* 14 (4): 407–438.
- Chan, C., & Xiong, Y. 2007. The features and forces that define, maintain and endanger Beijing courtyard housing. *Journal of Architectural and Planning Research* 24(1): 42-64.
- Chiou, S., & Krishnamurti, R., 1995. The grammar of Taiwanese traditional vernacular dwellings. *Environment and Planning B: Planning and Design*, 22 (6): 689-720.
- Chiou, S., & Krishnamurti, R., 1996. Example Taiwanese traditional houses. *Environment and Planning B: Planning and Design*, 23(2), 191-216.
- Chiou, S., & Krishnamurti, R., 1997. Unravelling fēng-shuǐ. *Environment and Planning B: Planning and Design* 24(4): 549-592.
- Deng, Y., 2004. *Beijing Siheyuan*. Hebei: Hebei Education Press.
- Duan, B., 2016. *Beijing Siheyuan Zhi [Beijing Siheyuan Chronicle]*. Beijing: Beijing Press.
- Duarte, J., 2005. Towards the Mass Customization of Housing: The Grammar of Siza's

- Houses at Malagueira. *Environment and Planning B: Planning and Design* 32(3): 347-380.
- Flemming, U., 1987. The role of shape grammar in the analysis and creation of designs. In *Computability of Design*, ed. Y.E. Kalay, 245-272. New York: Wiley-Interscience.
- Huang, B., Chiou, S., & Li, W. 2019. Study on courtyard residence and cultural sustainability: Reading Chinese traditional Siheyuan through Space Syntax. *Sustainability* 11(6): 1-15.
- Li, A., 2001. A shape grammar for teaching the architectural style of the Ying Zao Fa Shi. PhD diss., Massachusetts Institute of Technology.
- Li, D., 2016. Computational re-interpretation of heritage architecture, PhD thesis, University of Liverpool.
- Li, J., 1103. *Ying Zao Fa Shi*. Dongjing: Song Dynasty of China.
- Li, J., 2010. Qianlong Jingcheng Quantu Zhong de Heyuan Jianzhu Yu Hutong Jiefang Kongjian Tanjiu [Research of Courtyard Building and Hutong Block Modes on the Qianlong Capital Map]. *Journal of Chinese Architecture History*, 2010(00):317-346.
- Liang, S., 2006a, Zhongguo jianzhu zhi liangbu “wenfa keben” [Chinese Architecture’s Two “Grammar Book”], *Architectural Digest*, Sanlian Bookstore, Beijing.
- Liang, S., 2006b. *Qing Gongbu Gongcheng Zuofa Zeli Tujie* [Diagrams of Structural Regulations by Qing Work Ministry]. Beijing: Tsinghua University Press.

- Liang, S., 2006c. *Qing Shi Yingzao Zeli* [*Qing Style Building Regulation*]. Beijing: Tsinghua University Press.
- Liu, J., & Wu, Z. 2015. Rule-based generation of ancient Chinese architecture from the Song dynasty. *Journal on Computing and Cultural Heritage* 9 (2): Article 7.
- Lu, X. & Wang, Q., 1996. *Beijing Siheyuan*. Beijing: China building industry press.
- Lu, X. & Wang, Q., 2013. *Beijing Siheyuan Human Settlements Environment*. Beijing: China building industry press.
- Ma, B., 1999. *Beijing Siheyuan Jianzhu* [*Beijing Siheyuan Building*]. Tianjin: Tianjin University Press.
- Murphy, M., McGovern, E., & Pavia, S., 2013. Historic building information modelling- adding intelligence to laser and image-based surveys of European classical architecture. *ISPRS Journal of Photogrammetry and Remote Sensing* 76: 89-102.
- Ni, Y., 2009. *Study on Typology of Beijing Hutong Siheyuan*. Beijing: China Building Industry Press.
- Qing Department of Qing Dynasty. 1733. *Gongcheng Zuofa Zeli* [*Structural Regulations*]. Beijing: Qing Dynasty of China.
- Stiny, G., 1977. Ice-Ray: A Note on the Generation of Chinese Lattice Designs. *Environment and Planning B: Planning and Design* 4(1): 89-98.
- Stiny, G., 2006. *Shape: talking about seeing and doing*. Cambridge: The MIT Press.
- Tedeschi, A., 2011. *Parametric Architecture with Grasshopper*. Brienza: Le Penseur.
- Villari, S., 1987. *J.N.L. Durand: 1760-1834: Art and science of architecture*. New York:

Rizzoli.

Xiong, L., Xiong, W. & Zhang, H., 2013. Gulou Structure Grammar and its Computer Implementation. In *Proceedings of the 31st International Conference on Education and research in Computer Aided Architectural Design in Europe* 725-734

Yi, D., Yu, L. & Hong, Y., 1996, *Zhongguo Gudai Fengshui Yu Jianzhu Xuan Zhi* [Geomancy and the selection of architecture replacement in ancient China]. Shijiazhuang: Hebei Science Press.

Zhang, D., 2015. Classical Courtyard Houses of Beijing: Architecture as Cultural Artifact. *Journal of Space and Communication* 1(1): 47-68.

Zhang, S., 2009. *Huang Di Zhai Jing Fengshui Xinde* [Discoveries in Fengshui from Dwelling Canon of the Yellow Emperor]. Beijing: Tuanjie Press.

Zhao, J., 2011, *Huitu Dili Wu Jue* [Five Tips for Geographic Mapping]. Beijing: Hualing Press

Zhao, Y., 2013. *Beijing Siheyuan traditional constructional technique*. Hefei: Anhui Science and Technology Press.