

Association for Information Systems

AIS Electronic Library (AISeL)

ICEB 2002 Proceedings

International Conference on Electronic Business
(ICEB)

Winter 12-10-2002

The Feasibility and Method of News Mass Customization (NMC)

Youqin Zhu

Yongxian Wang

Follow this and additional works at: <https://aisel.aisnet.org/iceb2002>

This material is brought to you by the International Conference on Electronic Business (ICEB) at AIS Electronic Library (AISeL). It has been accepted for inclusion in ICEB 2002 Proceedings by an authorized administrator of AIS Electronic Library (AISeL). For more information, please contact elibrary@aisnet.org.

The Feasibility and Method of News Mass Customization (NMC)

Youqin Zhu

School of Economics&Management
Tsinghua University
Beijing, China
zhuyq@langchao.com.cn

Yongxian Wang

School of Economics&Management
Tsinghua University
Beijing, China

Abstract

Mass Customization (MC) is a new production mode developed from the combination of Mass Production (MP) and single customization. News businesses putting the News Mass Customization (NMC) in force has its inherent advantages and NMC is a new way to get competence. The paper firstly analyzes two problems—notation of MC and NewsML which have strong relation with NMC. Secondly, Compared with the MC rules in manufacturing industry, we draw the feasibility of NMC in News Businesses. Finally, according to the usage of Petri nets, we describe the NMC process and provide a detailed implement method.

Keywords: News Mass Customization (NMC); NewsML; Personalized News

1. Introduction

With the rapid development of society and civilization, the post-industrial era characterized by information technology (IT) and cybernation [4] is coming. While the traditional industrial economics has been replaced by knowledge economics, the useful information has been noted as a new and rare resource. At the same time, with the development of Internet, the emergence of all kinds of Websites like the bamboo shoots in the spring rain, and the electric commerce is gradually recognized as a new model of transaction. Any coin has two sides, we are now locating at a situation that we can not get the rapid and exact information even if the total number is enormous, as the saying goes “Rich data, Poor information”. How to provide the exact information for special customers is always to make the researches confused [1][2].

The word of Mass Customization (MC) stems from

the manufacturing industry, its core is to provide the personalized and customized products or/and services for customers with low cost and high efficiency of Mass Production (MP)[3][4]. On one hand, in the fields of news, the number of documents in database of news media is becoming more and more enormous, and the volume of the data is increasing exponentially. The news issuing and transmitting format is complex, the incompatibility is exist between them as well. On the other hand, while it is becoming more critical for customers to the news quality, the traditional standard has been replaced by a new mode which has open, interfacing, free and equal properties. The news with normalized, varied and personalized attributes is the tendency, and a new technology criteria as the basic platform is needed which can organize and issue colossal news information.

2. The notation of MC and the criteria of news—NewsML

Changing market, global competition and customized demand are severely challenging the traditional production modes. There are two elementary modes—Mass Production and single customization in recent years. The MP can provide the monotony product with low costing and high efficiency while single customization provides variable handmade products with high costing and low efficiency. Both of them have their merits and defects. Getting an efficient production mode is a seeking object for businesses to combine their merits and discard their defects. In the past decades, with the development of network and computers and the emergency of management modes such as Concurrent Engineering (CE), Supply Chain Management (SCM) and Customer Relationship Management (CRM), it is possible

that business produce customized production with the costing and efficiency of Mass Production (MP). In 1992, the master piece *Mass Customization: the New Frontier in Business Competition* [3] by an American scholar B. Joseph Pine II symbolizes the birthday of MC theory.

MC is that businesses use advanced technology such as Computer Aided Technology (CAD/ CAM/ CAPP), Flexible Manufacturing System(FMS), Group technique(GT) and advanced management modes such as CE,SCM,Business Process Reengineering (BPR) and CRM. to provide customized products and/or services for customers and put all or partial product process reengineering in force to produce products which costing and efficiency is the same or similar to that of MP[3][4][5]

Generally, Mass Customization has the following attributes:

(1) MC is a push/pull mixed production mode oriented to customers' demand.

(2) MC is a kind of Agile manufacturing mode to improve the adaptive ability of environment.

(3) MC emphasizes the customization in different levels. The similarity to the variety strategy is to satisfy the personalized demands.

(4) On the base of the standard, reasonable and generalized parts, MC tries to design modularized product so as to provide cheap and customized product in rapid speed.

(5) MC design is divided into new product development and distorted design. They have the sequent relation. The first part is to satisfy the low costing and the second is to satisfy the customized demands.

(6) MC emphasizes the support of IT and flexible manufacturing technology.

From the point of notation of MC, if a news business wants to provide NMC for customers, it must have a new technology criteria to organize and issue colossal news information. International Press Telecommunications Council (IPTC) issued a news logo language (NewsML version 1.0) in October, 2000. It gives a new lease to news sharing and issuing, and it is important for news businesses to satisfy customized demands.

NewsML is not only a terse, extensible and flexible standard as a news treatment framework, but also a

format standard for the uniform description, package, storage and transmission of media news [1]. It is convenient for computer to handle. The news with different contents supplier can be shared and exchanged on the base of it.

In sum [2], NewsML document always has three parts, DTD or Schema for defining the NewsML document logic structure, XSL for defining NewsML document display format and News document file which is written according to the DTD or schema .In addition, DTD(Document Type Definition) is a new series of syntax rules for news information marker sign. It defines the element contained, element attributes and relationship among these elements .XSL(extensible Stylesheet Language) is responsible for the display format of document in user's look through terminals. Different format of the same news are displayed with different stylesheet . NewsML document file is the main of NewsML document which refers to the file contents on the base of DTD or schema [7][8].

3.The feasibility of NMC

In the fields of news businesses, news is its products .The concerning and valuable customized news maybe regarded as a type of MC. From the analyzed attributes of MC, NMC also has these related attributes.

News occurs at all the time and the number is enormous. When a reader prints concerned keywords, network may arrange the related news from enormous databases to meet the reader's requirement.

A good Websites and corresponding news institution must focus on the social situations and issue the messages and policies to readers in time, so we must issue news with agile model.

While news contents are varied and can be classified, readers may look through interested news, at the same time, almost all the news agencies issue concerned news corresponding special events, thus embody the variety of news.

In order to get exact and valuable information and ensure the issued channel straightaway, we must get the rapid transmitted measure by using the standard, reasonable and generalized issue format.

In manufacturing fields, the design process of MC

has two stages. And maybe there are two stages in NMC. For example, a news group may have several kinds of newspaper, the core content concerned with domestic and foreign may be similar, but in order to reflect respective characteristic of different newspaper, the exact content is different.

The news issuing is supported by computer and IT in itself, the intention of flexible manufacturing is to manufacture customized products and/or services in rapid speed. While news itself needs to record the occurred and occurring matters ,the flexibility totally depends on the reporters and the editors' ability

Although there are several successful cases with MC in foreign such as DELL computer corporation, Motorola corporation and Anderson door and window corporation. Seldom businesses take the MC in our country. The essential reason is that our business can not implement the three steps as a seamless whole from product specification to product logistics [6].

(1)Elicitation: a mechanism for interacting with the customer and obtaining specific information

(2)Process: flexibility: production technology that manufacture the product according to the information.

(3)logistics: subsequent processing stages and distribution that are able to maintain the identity of each item and to deliver the right one to the right customer

Generally speaking, the customers are often amazed at deciding what they want. They are easily overwhelmed by too many selections on a store shelf or a Web page. Business may make use of identification, customers' selections from menus of alternative, physical measurements and reactions to prototypes to complete, but all these measures are expensive in China .In news fields, business may list a questionnaire through network, customer may leave names and preference, and then use the special database to store them, and either customer or business itself may accept the method.

As for the flexible manufacturing, businesses must put into much of human, material and financial resources for the advanced equipment characterized computer and network communication. The situation is not prevailing even abroad. Because of the peculiarity of product in news fields, news business may not invest these expensive equipments and only depends on the human and network

intelligence to provide news for customers.

After the product is manufactured with customers' specific information, here may be several additional processing and transportation tasks. It is not easy to transport the special products to special customer, it depends on the developed logistic system. But for the news business, it is easy to achieve , It may use network to fulfill them without any waste of human, material and financial resource. Customer may open his own mailbox to get the special products.

According the analysis mentioned above, we may conclude that it is feasible to accomplish NMC in news business.

4.NMC process description based on Petri nets[9][10]

. As mentioned above, we emphasize that NewsML is a general platform for news issuing and sharing, NMC process is the application of the NewsML.

In the full description, we take Petri nets as a tool. Place means information status represented by circle. Transition means the handling of concerned data represented by box.

As Fig.1 shows, the NMC process mainly contains three components, requirement interface process, information integrated process and data mining and issuing process. Place p5 is the customers' database recording customers' characteristic, when customer print keywords, we may analyze customers' characteristic according to the keywords and the special database. After getting the required information , we renew and store new records. Places p7, p8, p9 are the representatives of all kinds of databases, news business integrate these databases by an agent mechanism and get the integrated information which provides operation objects for data mining. According the mined data, we divide them into two parts and store in places p12 and place p13.

5.Conclusions

NMC is a new way for news businesses to provide top-quality and customized news for readers. It can win competency and customers' appeal. Based on the market situation and news issuing and sharing faults, we firstly analyzed notation of MC and NewsML, which are

strongly related to NMC, and explained the attributes of MC in manufacturing industry and the attributes and components of NewsML as well. Secondly, the feasibility of NMC is analyzed by the comparison of news businesses and manufacturing ones. At last, we use Petri nets as a tool to described the NMC process based on the NewsML, as figure 1 shows that the combined measure is

taken of requirement characteristic and data mining. And agent mechanism is used to integrate all kinds of database and then provide customized news for customers. As we know the concept of NMC is proposed as a new thing, there is still a long way to go. In this paper we just explored the feasibility and method in theory, the full application is to be studied in the future.

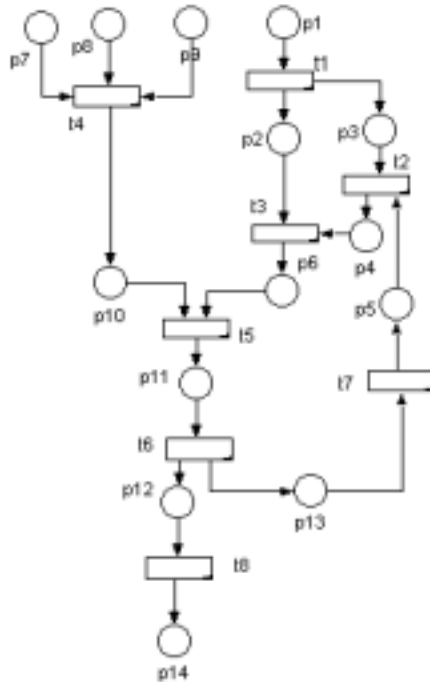

Fig.1 NMC process description based on Petri nets

Table 1 The notation of places and transitions

p1	customer's request	p12	mined information satisfied with customers
p2	wanted keywords	p13	new characteristic of customers
p3	customer data	p14	information sent to customers
p4	customer characteristic,	t1	input requirement
p5	customer database	t2	analyze customer's characteristic
p6	information satisfied with customers' requirement	t3	analyze information
p7	DataBase A	t4	integrate DataBase
p8	DataBase B	t5	data mining based on DataBase
p9	DataBase C	t6	analyze mined data
p10	integrated information of Database	t7	renew customers' DataBase
p11	mined information	t8	send valuable information to customers

References

- [1] *NewsML V1.0 Functional Specification* at <http://www.iptc.org>, Dec.2001
- [2] <http://www.newsml.org/NewsMLweb/webpage.xml>, Dec,2001
- [3] David.M.Anderson,B.Joseph Pine II. *Agile Product Development for Mass Customization*, Niche Market, JIT, *Built-to-Order and flexible Manufacturing*, McGrew-Hill, 1997
- [4] B.Joseph Pine II. *Mass Customization: The new Frontier in Business Competition*. Boston, Massachusetts, Harvard Business School Press.1993.
- [5] Giovanni Da Silveira, Denis Borenstein, Flavio S.Fogliatto," Mass customization: Literature review and Research directions". *International Journal of Production Economics*.2001,72:1-13
- [6] Paul Zipkin. "the limit of mass customization," *MIT Sloan Management Review*, Spring, 2001: 81-87
- [7] Liu DeGui, " Overview about XML development," *Microcomputer & its application*. 2000, 19(5): 1-6. (刘德贵, XML 发展综述.微型机与应用,2000,19(5):1-6)
- [8] Michael Erdmann ,Rudi Studer "How to structure and access XML documents with ontologies, " *Data&Knowledge Engineering* , 2001,36: 317-335
- [9] Ying Yan,Bai QingHua,Qing Geng. " Research of Information mining Based on multi Agents, ". *Application research of Computer*.1999,16(12): 20-22 (殷燕,白庆华,秦耕等.基于 Multi Agent 技术的信息挖掘系统研究.计算机应用研究 1999,16(12):20-22)
- [10] Pan JinGui,Hu XueLian, Li Jun, Zhang LingLing. " Design and Implementation of a personalized Information Retrieval Agent," *Journal of Software*.2001,12(7):1074-1079. (潘金贵,胡学联,李俊,张灵玲.一个个性化的信息搜集 Agent 的设计与实现.软件学报, 2001, 12(7) :1074-1079)