

The University of Southern Mississippi
The Aquila Digital Community

Master's Theses

Spring 2020

Tonal Expectations Defining Narrative Archetypes

Seth Weesner

Follow this and additional works at: https://aquila.usm.edu/masters_theses

 Part of the [Music Theory Commons](#)

TONAL EXPECTATIONS DEFINING NARRATIVE ARCHETYPES

by

Seth Weesner

A Thesis

Submitted to the Graduate School,
the College of Arts and Sciences
and the School of Music
at The University of Southern Mississippi
in Partial Fulfillment of the Requirements
for the Degree of Master of Music

Approved by:

Dr. Douglas Rust, Committee Chair
Dr. Danny Beard
Dr. Joseph Brumeloe
Dr. Edward Hafer

Dr. Douglas Rust
Committee Chair

Dr. Jay Dean
Director of School

Dr. Karen S. Coats
Dean of the Graduate School

May 2020

COPYRIGHT BY

Seth Weesner

2020

Published by the Graduate School



THE UNIVERSITY OF
SOUTHERN
MISSISSIPPI®

ABSTRACT

This thesis examines the contributions of tonal analysis to narrative readings of three nineteenth-century pieces. The method used originates from the work of two theorists, Byron Almén and Fred Lerdahl. Almén's 2008 book, *A Theory of Musical Narrative*, outlines narrative archetypes. Lerdahl's 2004 book, *Tonal Pitch Space*, provides a sophisticated approach to tonal analysis. These methods are combined to analyze striking modulations in Robert Schumann's "Dein Angesicht" Op. 127, no. 2, tonal ambiguity in Johannes Brahms's "Der Kranz" Op. 84, no. 2, and the lack of tonal closure in Gabriel Fauré's "Hymne" Op. 7, no. 2. These striking features and their changes are tracked over the course of each piece. This creates the narrative analysis and allows a narrative archetype to be applied to the piece.

ACKNOWLEDGMENTS

I gratefully acknowledge Dr. Douglas Rust, my advisor, for his patience, insightfulness, and encouragement during the thesis process. During my first year in the program, Dr. Rust introduced me to narrative analysis. Conversations with Dr. Rust during and outside of class allowed me to explore narrative analysis and develop my thesis topic.

I acknowledge my entire committee – Dr. Douglas Rust, Dr. Joseph Brumeloe, Dr. Danny Beard, and Dr. Edward Hafer – for their guidance and support making me develop as a music theorist and teacher during my time at The University of Southern Mississippi.

DEDICATION

This thesis is dedicated to Sarah Jenkins who blesses me with her unyielding support and unconditional love every day.

I also recognize my parents, Jeff Weesner and Karen Weesner, for allowing me to pursue my passions.

TABLE OF CONTENTS

ABSTRACT	ii
ACKNOWLEDGMENTS	iii
DEDICATION	iv
LIST OF ILLUSTRATIONS	vi
LIST OF MUSICAL EXAMPLES	vii
CHAPTER I - INTRODUCTION	1
CHAPTER II – A THEORY OF MUSICAL NARRATIVE	7
CHAPTER III – ROBERT SCHUMANN’S “DEIN ANGESICHT” OP. 127 NO. 2	15
CHAPTER IV – JOHANNES BRAHMS’S “DER KRANZ” OP. 84, NO. 2	32
CHAPTER V – GABRIEL FAURÉ’S “HYMNE” OP. 7, NO. 2	46
WORKS CITED	64

LIST OF ILLUSTRATIONS

Figure 1. Lerdahl's Basic Space – C Major	2
Figure 2. Justifying C Major on Different Levels	3
Figure 3. Lerdahl's Region — Major Key	4
Figure 4. Difference between C major to D minor harmonic with one region and multiple regions	5
Figure 5. mm. 1-9 analyzed in the Basic Spaces Eb Major and Bb Major	20
Figure 6. Tonal Regions (a) Eb major and (b) Bb major with arrows showing harmonic progression	21
Figure 7. Diagram of Keys in the B Section of Robert Schumann's "Dein Angesicht" ..	25
Figure 8. Tonal Regions of "Dein Angesicht's" B Section	26
Figure 9. Tonal regions diagram of "Dein Angesicht's" A' section (a) mm. 18-21 (b) 22-26.....	29
Figure 10. Basic Spaces D major and G minor in "Der Kranz" mm. 1-6.....	35
Figure 11. Regions D major, G minor, and Bb major in "Der Kranz" mm. 1-6.....	36
Figure 12. Regions D major and Bb major from "Der Kranz" mm. 7-12	37
Figure 13. Region Bb major in "Der Kranz" mm. 13-16.....	38
Figure 14. Regions D major and D minor in "Der Kranz" mm. 17-28.....	39
Figure 15. Regions G major and G minor in "Der Kranz" mm. 29-50.....	42
Figure 16. Regional Analysis of Fauré's "Hymne" Op. 7 no. 2	49

LIST OF MUSICAL EXAMPLES

Musical Example 1 Text to Schumann’s “Dein Angesicht” with Translation	15
Musical Example 2 Roman Numeral Analysis of Robert Schumann’s “Dein Angesicht” Op. 127, no. 2, mm. 1-9	18
Musical Example 3 Form Diagram of Robert Schumann’s “Dein Angesicht” Op. 127, no. 2.....	18
Musical Example 4 Harmonic progression of the antecedent phrase in Roman numerals	21
Musical Example 5 Bach, Chorale No. 298, Weg, mein Herz, mit den Gedanken	22
Musical Example 6 Roman Numeral Analysis of Robert Schumann’s “Dein Angesicht” Op. 127, no. 2, mm. 9-17	24
Musical Example 7 Roman Numeral Analysis of Robert Schumann’s “Dein Angesicht” Op. 127, no. 2, mm. 17-31.....	28
Musical Example 8 Form Diagram of Schumann’s “Dein Angesicht” with Poetic Plot..	30
Musical Example 9 Hans Schmidt’s Poem “Der Kranz”	32
Musical Example 10 A Form Diagram of Johannes Brahms’s “Der Kranz” Op. 84, no. 2	33
Musical Example 11 Roman Numeral Analysis of Johannes Brahms’s “Der Kranz” Op. 84, no. 2, mm. 1-6	34
Musical Example 12 Roman Numeral Analysis of Johannes Brahms’s “Der Kranz” Op. 84, no. 2, mm. 7-15	37

Musical Example 13 Roman Numeral Analysis of Johannes Brahms’s “Der Kranz” Op. 84, no. 2, mm. 16-28	39
Musical Example 14 Roman Numeral Analysis of Johannes Brahms’s “Der Kranz” Op. 84, no. 2, mm. 29-39	41
Musical Example 15 Roman Numeral Analysis of Johannes Brahms’s “Der Kranz” Op. 84, no. 2, mm. 40-50	42
Musical Example 16 Form Diagram of Brahms’s “Der Kranz” with Poetic Plot	43
Musical Example 17 Claude Baudelaire’s poem “Hymne”	46
Musical Example 18 Stanza’s Three and Five to Baudelaire’s “Hymne”	47
Musical Example 19 Form Diagram of Fauré’s “Hymne”	48
Musical Example 20 Roman Numeral Analysis of Gabriel Fauré’s “Hymne” Op. 7, no. 2, mm. 1-8.....	50
Musical Example 21 Roman Numeral Analysis of Gabriel Fauré’s “Hymne” Op. 7, no. 2, mm. 9-18.....	51
Musical Example 22 Roman Numeral Analysis of Gabriel Fauré, “Hymne” Op. 7, no. 2, mm. 19-27	53
Musical Example 23 Roman Numeral Analysis of Gabriel Fauré’s “Hymne” Op. 7, no. 2, mm. 28-36.....	54
Musical Example 24 Roman Numeral Analysis of Gabriel Fauré’s “Hymne” Op. 7, no. 2, mm. 37-44	56

Musical Example 25 Roman Numeral Analysis of Gabriel Fauré’s “Hymne” Op. 7, no. 2, mm. 45-52	57
Musical Example 26 Roman Numeral Analysis of Gabriel Fauré’s “Hymne” Op. 7, no. 2, mm. 53-60	59
Musical Example 27 Roman Numeral Analysis of Gabriel Fauré’s “Hymne” Op. 7, no. 2, mm. 61-68	60
Musical Example 28 Roman Numeral Analysis of Gabriel Fauré’s “Hymne” Op. 7, no. 2, mm. 69-76	61

CHAPTER I - INTRODUCTION

This thesis explores how nineteenth-century art songs can use the tonal system to express very different meanings. As will be seen in the following analyses, tonality can elicit different expectations in a song, depending upon how it is structured. These expectations are not the same across the pieces, nor do they share a common resolution. A composer's harmonic choices can significantly affect musical interpretation, even amongst songs that share the same form and phrasing. For this reason, this thesis will appropriate vocabulary from narrative analysis and demonstrate how it can aid interpretation. To illustrate this point, three nineteenth-century songs that share the same rounded binary form will be analyzed: Robert Schumann's "Dein Angesicht" Op. 127, no. 2, Johannes Brahms's "Der Kranz" Op. 84, no. 2, and Gabriel Fauré's "Hymne" Op. 7, no. 2. The similar form between pieces allows for the comparison of expectations arising from the tonal implications — resulting in three distinct musical narratives.

Narrative analysis is a new method in the theory community offering innovative approaches but requiring further development. This thesis focuses on narrative archetypes outlined by Bryon Almén in his 2008 book, *A Theory of Musical Narrative*. These archetypes — romance, comedy, tragedy, and irony — gain depth when combined with a sophisticated approach to tonal analysis. Fred Lerdahl's *Tonal Pitch Space* offers the needed approach to read the tonal implications of melodies and harmonies. With an understanding of the tonal implications, pieces can be categorized by narrative archetype. Before the thesis continues to its first analysis in Chapter 3, the rest of Chapter 1 will outline Lerdahl's methods to clarify his approach. Chapter 2 will assess the state of narrative analysis and Almen's methods. Lerdahl's methods start with melodic analysis.

According to Lerdahl, the pitches used in a melody can suggest a tonal center, but, in cases where the melody does not include all notes of a diatonic collection, more than one tonal interpretation may be possible. Step one in determining a tonic involves listing the pitches in alphabetical order to determine a diatonic collection. Lerdahl prefers diatonic collections that emphasize scale degrees 1 and 5 or outline the tonic triad.¹ This preference originates from Lerdahl’s division of tonal pitch space into five levels — root (a), fifth (b), triadic (c), diatonic (d), and chromatic (e).² Lerdahl uses the levels to construct a chart where the hierarchy of scale degrees tonic and dominant, and the tonic triad can be visualized (see Figure 1 in C major). Justifying a diatonic collection with pitches that only occur on the diatonic or chromatic level is not preferred because it does not emphasize the root, fifth, or triadic levels. Lerdahl’s approach allows for the dissection of tonally ambiguous music by giving preference to one of the diatonic collections present.

level a :	0											0	
level b :	0						7					0	
level c :	0			4			7					0	
level d :	0	2		4	5		7		9		11	0	
level e :	0	1	2	3	4	5	6	7	8	9	10	11	0

Figure 1. *Lerdahl’s Basic Space – C Major*

¹ Lerdahl, Fred, *Tonal Pitch Space*, (Oxford, UK: Oxford University Press, 2004), 47.

² *Ibid*, 47.

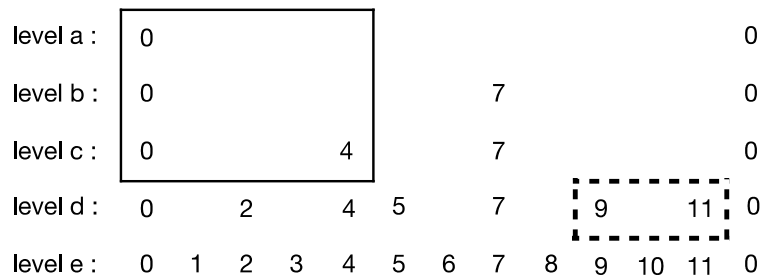

Figure 2. *Justifying C Major on Different Levels*³

Figure 2 demonstrates one application of Lerdahl’s preferences when justifying C major. The pitches C (0) and E (4) establishing C major are preferred because they involve tonic and another note within the tonic triad. Using pitches A (9) and B (11) would not be a preferred justification of C major because they only occur at level d (the diatonic level).⁴ These preferences limit melodic tonal interpretations and help clarify tonally ambiguous melodies. After this brief coverage of Lerdahl’s melodic approach, similar preferences are used when analyzing harmonic progressions.

Harmonic progressions that follow a Schenkerian phrase model, tonic - predominant — dominant during a phrase, may have a straight-forward analysis, but not all phrases are harmonized in this manner.⁵ Some ambiguous progressions become clearer with Lerdahl’s analytical techniques. Following his method, the triads built on each pitch of a diatonic collection constitute a region.⁶ Figure 3 displays Lerdahl’s

³ Lerdahl, *Tonal Pitch Space*, 195. Figure 5.1e.

⁴ *Ibid*, 194.

⁵ Laitz, Steven G., *The Complete Musician: An Integrated Approach To Tonal Theory, Analysis, and Listening*, 3rd edition, (Oxford, UK: Oxford University Press, 2012), 200.

⁶ Lerdahl, *Tonal Pitch Space*, 53-59.

notation of a major region — the top row contains iii, V, and viio, the middle row contains vi, I, and iii, and the bottom row contains ii, IV, and vi.

iii	V	vii ^o
vi	I	iii
ii	IV	vi

Figure 3. *Lerdahl's Region — Major Key*

Based on the chords in a progression, one should decide what regions or tonalities are possible for the progression. Depending on the harmonic progression, not every triad from the region must be used; the preferred analysis emphasizes tonic and dominant (I and V) and follows the circle of fifths. If the progression requires an interpretation with more than one region, preferred interpretations are the shortest around the circle of fifths and feature tonic and dominant in the new and old regions.⁷ In the Figure 4, interpretation (a) demonstrates a progression from C major to D minor within the key of C major and interpretation (b) shows the progression as two separate tonics. (a) is preferred because it involves tonic and remains within a region. (b) is not preferred because both chords are tonics with no dominant support and more than one region involved. With an understanding of Lerdahl's approach to tonal melodic and harmonic content, this thesis turns its attention to narratology.

⁷ Lerdahl, *Tonal Pitch Space*, 204.

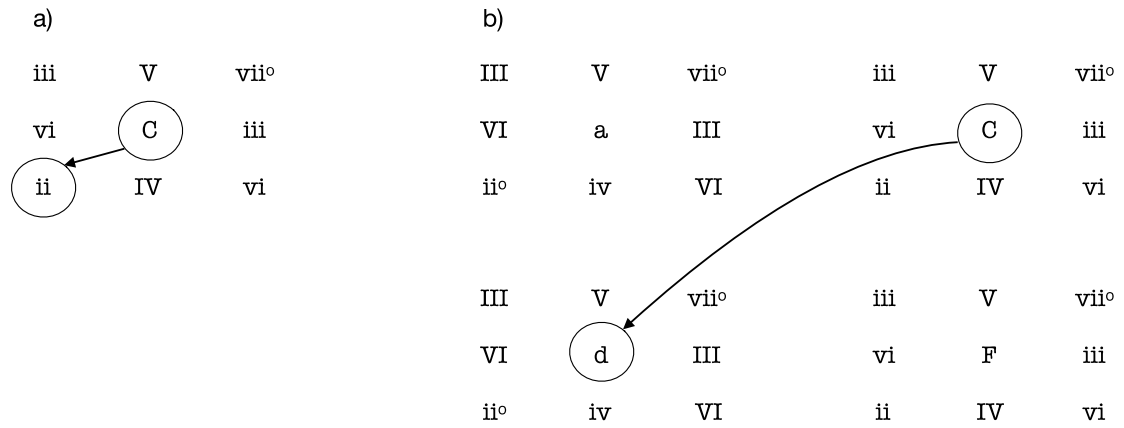

Figure 4. *Difference between C major to D minor harmonic with one region and multiple regions*⁸

This thesis explores how the tonal analysis of Fred Lerdahl informs the narrative analysis of Byron Almén. After a discussion of the piece's poetic text, the song is formally and harmonically analyzed illustrating the composer's incorporation of the written narrative into the music. This compositional strategy allows the listener to hear the narrative, but what does the listener hear? Simple characterizations of mood — happy v. sad — as concomitant with major and minor modes do not work in contexts such as Schumann's "Dein Angesicht", where the piece tells a tragic story, but remains in major the entire time. Bridging the gap between traditional form and Roman numeral analysis methods on the one hand and the meanings a listener might perceive on the other hand leaves a lot of territory to explore. This thesis aspires only to take the first few steps in a new direction by adopting some initial ideas from Byron Almén's *A Theory of Musical Narrative*. This thesis includes one chapter for each of the three songs chosen. Each

⁸ Lerdahl, *Tonal Pitch Space*, 197. (a) Figure 5.2a (b) Figure 5.2c

chapter provides a discussion of the text used, sample analyses of form and harmony in the song, and concludes with assigning a narrative archetype. The next chapter defines terms and concepts from narrative music theory.

CHAPTER II – A THEORY OF MUSICAL NARRATIVE

In 2001 Fred E. Maus wrote an article for the *New Grove Dictionary of Music and Musicians* on narratology. A style of music analysis beginning in the 1980s, the study of narrative is associated historically with east European formalism and European structuralism, intellectual movements that borrowed tools from social science, focused on studying myth and literary fiction to discover recurring patterns. Formalism and structuralism emphasized that story-telling follows norms of which the story-teller and audience may not be conscious. Beginning in the late 20th century, music theorists and critics often explored the possibility of narrative in non-texted, non-programmatic music from European concert traditions by combining historical interpretation, technical music theory, philosophical study of expression and representation, and semiotics. In narrative analysis, instrumental music requires identification of agents or actors in the form of themes or instruments. Plot is a central issue within narratology, and while Maus identifies Todorov, McClary, and Newcomb as theorists proposing different plot archetypes, the greatest improvements to plot description would not arise until after Maus's article. Another area of interest for narratologists is historically based identification called topics, started by Ratner and later used by Agawu, Allenbrook, and Hatten. Maus saw topics as an important aspect to narrative leading him to state, "the succession of topics in a piece must affect the narrative interpretation of that piece." In the final paragraphs of the entry, Maus reflects that progress in narratology was inhibited by poor timing of the rise of the field, by the 1980s formalism and structuralism seemed dated to many literary and cultural scholars. Several writers challenged the ability for instrumental music to have narrative qualities. Kivy believed that music could only

illustrate a story not tell, Kramer believed music could not contain reflexive self-commentary, and Nattiez saw an issue with a lack of distinction between subject and predicate. The failures in analogies led Kerman, Maus, and Newcomb to suggest that instrumental music is closer to drama than prose narrative.⁹

In 2004, Michael Klein contributed to narratology with his article “Chopin’s Fourth Ballade as Narrative”, tackling the possibility of narrating in the past tense through music. The issue of past tense narration is answered with Klein’s relation to poetic ballade narrators, who are detached from the tale. Klein assumes the existence of a musical persona as the implicit narrator in his analysis of Chopin’s Fourth Ballade. Robert Hatten’s description of expression found in topics and theory of markedness and correlation allows Klein to define the musical persona in the ballade. Klein notes that traditionally Chopin’s four ballades are analyzed in sonata form, but analysis through the expressive lens proves more productive.¹⁰ One of the expressive qualities Klein illuminates is that of the apotheosis or climax. As Klein compares and contrasts the sections of the ballade, a description of the plot unfolds. After the plot has been described, Klein remarks that the narrator in “the Fourth Ballade idealizes the pastorale in opposition to the waltz, which stands as a synecdoche for the urban life of the salon.”¹¹ In

⁹ Fred E. Maus, “Narratology” In *New Grove Dictionary of Music and Musicians*, ed. Stanley Sadie, (Oxford: Oxford University Press, 2001).

This paragraph is a summary of Maus’s article.

¹⁰ Michael, Klein, “Chopin’s Fourth Ballade as Musical Narrative”, *Music Theory Spectrum* 26.1 (Spring 2004) 31.

While difficult to refute the expressive qualities that Klein identifies, one wonders what insights Hepokloski’s 2006 *Elements of Sonata Theory: Norms, Types, and Deformations in the Late Eighteenth Century* would have offered when analyzing the “unruly sonatas.”

¹¹ *Ibid*, 49.

addition to providing an insightful analysis of Chopin's Fourth Ballade, Klein contributes to the broader discussion of musical narrative.

While not responding directly to Maus, Klein attempted to answer issues plaguing the field of narratology by using topics in conjunction with form diagrams to illustrate the plot, a component Maus saw as vital in his 2001 article. While used by Hatten and others to identify the expressive qualities of a piece, topics had not been used to systematically define the musical narrative or plot. Klein pairs topics such as waltz, sublime, pastorale, canon learned style, apotheosis, and tragic with a form diagram to reveal the expressive logic. This expressive logic is directed towards apotheosis, "a special kind of recapitulation that reveals unexpected harmonic richness."¹² At the end of the article, doubt about the field surfaced with Klein stating, "intuition tempered by semiotic and musical structures gets us only so far in narrative analysis" and "with so many variables in history and intertext, semiotics and hermeneutics, ideology and subjectivity, hopes seem dim in arriving at interpretations that might foster agreement among competent listeners."¹³ Narratology still required a system that would yield consistent results. The most notable system would arrive in Byron Almén's 2008 book *A Theory of Musical Narrative*.

In his review of *A Theory of Musical Narrative* by Almén, Douglass Seaton states that the book contains "the most important contributions to this area of scholarship and presents musical narrativity in a synthetic and original framework."¹⁴ In his book, Almén is introducing defined narrative archetypes — romance, tragedy, comedy, and irony — to

¹² Michael, Klein, "Chopin's Fourth Ballade as Narrative", 31.

¹³ Ibid, 52.

¹⁴ Douglass, Seaton, "A Theory of Musical Narrative", *Journal of Musicological Research* 30 (2011) 72.

better identify the discourse of a given piece. The methodology used in the book relies on the work of James Lizska and Northrop Frye, combining to form three levels of analysis: agential, actantial, and narrative.¹⁵ The three narrative levels are similar in terms of scale to the three levels in Schenkerian analysis, the foreground, middle ground, and background. The agential level, the smallest level, identifies the minute musical elements and characterizes them. The actantial level is characterized by the smaller agential elements grouped into sections. After the different sections are defined on the actantial level, the narrative archetype, the broadest level, can be defined by examining the interactions occurring on the actantial level. While there were significant developments and insights regarding musical semiotics in the 1990s, there was not a consensus. Almén provided, as David Bretherton notes, a “solid theoretical framework.”¹⁶

While there is praise for Almén’s work on musical narrative, there are two common criticisms — too many new terms and subjectivity in the methodology — in the reviews of Kofi Agawu (2009), Arnold Whittall (2010), Douglass Seaton (2011), and David Bretherton (2012). The first common critique is the abundance of terminology creating a “barrier in comprehension.”¹⁷ Seaton disagreed with the term narrative to the degree that by the end of his review he has discarded the term narrative and replaced it with plot. The second common critique amongst the scholars is the lack of a methodology that systematically categorizes a piece in one of the narratives; Agawu noted, “...as long as members of certain interpretive communities firmly subscribe to notions of more or

¹⁵ James, Lizska, *The Semiotic of Myth: A Critical Study of the Symbol*. (Bloomington: Indiana University Press, 1989)

Northrop, Frye, *Anatomy of Criticism: Four Essays*, (Princeton, N.J.: Princeton University Press, 1957)

¹⁶ David, Bretherton, “A Theory of Musical Narrative”, *Music Analysis* 31.3 (October 2012) 414.

¹⁷ *Ibid*, 415.

less sophisticated ways of reading tonal works, such disagreeing will be unavoidable.”¹⁸ Stemming from the second critique, Arnold Whittall criticized the lack of musical function — “Almén's notion of 'hierarchy', in thrall to his literary model gives too little weight to its musical function within the tonal system, as demonstrated most richly by Heinrich Schenker.”¹⁹ With these critiques in mind, this thesis focuses on defining Almén’s narrative archetypes with less subjective methodology.

Even with these strong critiques, Almén’s work on narrative remains one of the most important works in the field. The exploration of narrative continued in a collection of essays titled *Music and Narrative Since 1900*. In the nineteen different essays, theorists examine the narrative or discourse in music after 1900. In 2013, Seth Monahan contributed the article “Action and Agency Revisited” where he posed a hierarchical system of agencies. Toward the end of the article, Monahan reflected that agency shares many characteristics with the musical narrative Byron Almén proposed in his 2008 work. This led to the question — can music have narrative without agency or vice versa?²⁰ Through the newer prose on narrative music some of the adages remain — is there a defined methodology accompanying the system and can the system incorporate musical function? I believe so. Presented in the next chapters is my original approach; combining Lerdahl’s approach to tonality with Almén’s narrative archetypes creates a system with methodology incorporating musical function.

Throughout the examples in this thesis, musical meaning emerges through expectations created on the melodic and harmonic levels measured using Lerdahl’s

¹⁸ Kofi, Agawu, “A Theory of Musical Narrative” *Notes* 66.2 (December 2009) 277.

¹⁹ Arnold, Whittall, “A Theory of Musical Narrative” *Music and Letters* 91.2 (May 2010) 300.

²⁰ Seth, Monahan, “Action and Agency Revisited” *Journal of Music Theory* 57.2 (Fall 2013) 365.

approach. In Schumann's "Dein Angesicht", the melody and harmonies create the expectation that Eb is the tonal center; then the listener is blindsided by a sudden transition to G major, because of the previous expectations. The piece comes to a close in Eb major, but utilizes a modally-borrowed chord that recolors the tonality. In Brahms' "Der Kranz", the beginning of the lied is tonally ambiguous and explores multiple tonal regions throughout the piece. While Bb major, D major, and D minor are utilized early, the piece ends in G major in stark contrast to the suggestion of G minor connecting the early sections. In Fauré's "Hymne", G major is the tonal center for the majority of the piece, but avoidance of perfect authentic cadences in G major builds anticipation resolved only in the final measures of the piece. For an approach that accounts for these expectations and tracks them over the course of the entire piece, this thesis uses narrative analysis which is particularly suited to interpret these kinds of situations.

The musical narrative of a piece relies on the order or start to the piece. What does the listener hear first and how would they expect that music to continue? What striking musical contrasts later challenge those expectations? Are these conflicting impressions reconciled before the end of the composition? These are the kinds of questions explored in a musical narrative analysis. They help the analyst put together musical facts into an interesting account of a composition. Narrative analysis utilizes four archetypes from Northrop Frye — romance, tragedy, irony, and comedy — to describe music in terms of dramatic trajectory.²¹ These terms are broad descriptions of the composition's expectations and resolutions. The expectations are categorized as either order (the expected continuation of conditions at the outset of the piece) or transgression

²¹ Almén, *A Theory of Musical Narrative*, 64.

(musical contrasts that challenge the initial order). At the end of piece, the order or transgression is judged in terms of victory and defeat resulting in four pairs:²²

Romance: the victory of order.

Tragedy: the defeat of the transgression.

Irony: the defeat of order.

Comedy: the victory of the transgression.

Two clarifications must be added to these narrative archetype definitions — preference and chronological. When comparing definitions of romance and tragedy or comedy and irony, a problem surfaces because preference is not stated; if order is victorious in a romance, then the transgression was consequently defeated and vice versa. Romance and tragedy are equivalent in definition, when they should not be. The same problem exists between irony and comedy. To clarify the narrative archetypes, one must establish a preference for the transgression or order yielding four independent archetypes.

Romance: the victory of order. (Order is preferred)

Tragedy: the defeat of the transgression. (Transgression is preferred)

Irony: the defeat of order. (Order is preferred)

Comedy: the victory of the transgression. (Transgression is preferred)

²² Almén, *A Theory of Musical Narrative*, 225.

Chronologically, order is the initial musical syntax and a transgression is musical syntax that surfaces later and opposes the order. The chronological tracking of the order and the transgression generates a set of expectations, melodically or harmonically, that can be evaluated allowing for the four different narrative archetypes. Demonstrating this approach, this thesis will label the analyzed pieces with narrative archetypes.

The following analysis chapters apply the tonal approach of Fred Lerdahl to inform the narrative analysis of Byron Almén. First an analysis of the poem used in each art song will be supplied. Then the piece will be analyzed following Lerdahl's approach to melodies and harmonies. The chapter concludes by labeling each piece as one of the four narrative archetypes. With the thesis's methodology explained, an analysis of the three nineteenth-century songs may be conducted — beginning with Robert Schumann's "Dein Angesicht" Op. 127, no. 2.

CHAPTER III – ROBERT SCHUMANN’S “DEIN ANGESICHT” OP. 127 NO. 2

Published as a part of a collection of lieder “Fünf Lieder und Gesänge” Op. 127 in 1854, Robert Schumann’s “Dein Angesicht” Op. 127, no. 2 was originally composed as part of “20 Lieder und Gesänge”. Heinrich Heine’s “Lyrisches Intermezzo” provided the lyrics for “20 Lieder und Gesänge”, but after the removal of four songs became Schumann’s Op. 48, “Dichterliebe”, published in 1844.²³ “Dichterliebe” was dedicated to Wilhelmine Schröder-Devrient, a famous operatic singer of the time.²⁴ While published in Schumann’s later years, “Dein Angesicht” originally comes from the middle of his life.

Dein Angesicht so lieb und schön, Das hab' ich jüngst im Traum gesehn, Es ist so mild und engelgleich, Und doch so bleich, so schmerzenbleich.	Your face so lovable and fair: I saw it recently in a dream. It is so mild and angelic, and yet so pale, so pale with pain!
Und nur die Lippen, die sind rot; Bald aber küßt sie bleich der Tod. Erlöschen wird das Himmelslicht, Das aus den frommen Augen bricht.	And only your lips are red; but soon Death will kiss them pale. Out will go the heavenly light that reflects out from your innocent eyes.
Dein Angesicht so lieb und schön, Das hab' ich jüngst im Traum gesehn, Es ist so mild und engelgleich, Und doch so bleich, so schmerzenbleich.	Your face so lovable and fair: I saw it recently in a dream. It is so mild and angelic, and yet so pale, so pale with pain!

Musical Example 1 Text to Schumann’s “Dein Angesicht” with Translation ²⁵

²³ Daverio, John, and Eric Sams, “Robert Schumann”, Oxford Music Online, (Oxford, UK: Oxford University, 2001).

²⁴ Miller, Richard, *Singing Schumann: An Interpretive Guide for Performers*, (Oxford: Oxford University, 2005) 96-100.

²⁵ Eric, Sams, “Dein Angesicht,” *The Songs of Robert Schumann*, (London: Faber and Faber Ltd., 2011), ebook.

Heinrich Heine's poem, "Dein Angesicht", features an ironic narrative created by a dramatic breaking of mood at the end of the first stanza.²⁶ The opening two lines of the text create a mood of admiration dreamt by the poet as he describes the face of his beloved. Continuing the mood, the next line describes the beloved as angelic. Heine breaks the mood in the last line of the opening stanza as he informs us that the beloved is pale with pain. The tragic nature of the poem is intensified by the ironic twist from first stanza to second. In the second stanza, the poet fully commits to the change by informing the reader that Death will soon kiss the beloved's red lips pale and the heavenly light in her eyes will go out. Schumann musically incorporates Heine's breaking of mood at two different points in his setting, occurring first at the end of the opening stanza and second at Schumann's added repetition of the beginning stanza.²⁷ With the added repetition, Schumann adds another ironic layer. The first time the listener hears the stanza they are deceived. The second time the listener hears it they have knowledge of Heine's beloved's fate.

Eric Sams and Benjamin Binder provide two interpretations of Schumann's "Dein Angesicht." Sams identifies the three sections of the piece with separate characteristics. Musically the first section, paired with the first stanza, gives no indication of grieving. The middle section, Heine's second stanza, creates an eerie mood; the music remains in a major modality but repeated melodic phrases sound different. Schumann's return to the

²⁶ Benjamin, Binder, "Robert, Clara and the Transformation of Poetic Irony in Schumann's Lieder: The Case of 'Dein Angesicht,'" *Nineteenth-Century Music Review* 10 (Cambridge, MA: Cambridge University Press, 2013) 14.

In this article Binder is particularly interested in Heine's use of *Stimmungsbruch* or breaking of mood.

²⁷ Eric, Sams, "Dein Angesicht."

first stanza mourns the lost beloved. Binder's perspective is created by the analysis of the letters and relationship of Robert and Clara Schumann. Robert often asked Clara for portraits and other images of herself during times when the two were apart. Robert then struggled with his idealized version of Clara which conflicted with the real version of Clara captured in the portraits. The plot of "Dein Angesicht" represents this dilemma: Robert first looks at the images remembering his idealized Clara but, as he finds blemishes, he realizes that his idealized Clara is not in the images.²⁸ In their separate analyses, Sams and Binder both identify musical qualities that change with the stanzas, but does the poetic narrative persist without the text? To further explore the issues referenced in that question, a narrative analysis inspired by Almén (2008) will be developed for this lied to demonstrate ways that the musical structure can communicate irony independently from the poetic text.

²⁸ Binder, "The Case of 'Dein Angesicht,'" 18-20.

Half Cadence

Dein An - ge sicht, so lieb und schön, das hab' ich jüngst im Traum _ geseh'n. Es

Eb: I ii ⁹ — ⁸ / ₇ — ₆ V⁷ vii⁰ 7/ vi V⁷/ V⁷

Perfect Authentic Cadence

ist so mild und en - gel - gleich, und doch so bleich, so schmerzlich. Und

I V/ii ii⁶ V⁷ vii⁰ 7/ vi V⁷/ G major

Musical Example 2 Roman Numeral Analysis of Robert Schumann’s “Dein Angesicht”
Op. 127, no. 2, mm. 1-9

	A	B	A
	Eb Major m. 1-9	G Major m. 9-11	Eb Major m. 18-31
Eb:	I — V I — III	III	I — V V — I

Musical Example 3 Form Diagram of Robert Schumann’s “Dein Angesicht” Op. 127,
no. 2

Robert Schumann’s “Dein Angesicht” has two features that sound particularly striking — a surprising change in tonality, and a cadential motion that takes on motivic significance before it is reinterpreted later via modal borrowing. The piece has a rounded

binary form (shown in Musical Example 3) where the B section modulates to chromatic-third related keys. The first of the chromatic-third related keys has a striking sound and is paired with unexpected information in the text.

The opening parallel period (analyzed in Musical Example 2) features melodic content in Eb major that also hints at Bb major creating the surprise of G major at the end of the period. Following the method outlined in Tonal Pitch Space, we begin by analyzing the pitches from the melody. The antecedent's melody, measures 1-5, contains the pitch classes Bb, C, F, Eb, D, G, A, and Ab. Setting aside the pitch classes Ab and A for a moment, the diatonic collections of Bb major or Eb major are present because of the notes Bb, C, D, Eb, F, and G. Due to the harmonic support, the tonality of this section is Eb major but it is interesting that without the harmonic support, Lerdahl's approach would prefer Bb major. In Eb major, the melody begins and ends on scale degree 5 with little emphasis on the tonic pitch. Lerdahl would give preference to Bb major because the melody starts and ends on Bb; Lerdahl believed that the first sound heard would be assumed to be tonic.²⁹ The difference between interpretations is illustrated by the basic space charts of Eb major and Bb major (Figure 5). The pitch classes A and Ab help to decipher the best diatonic collection. Ab suggests the tonality as Eb major, while the A natural in measure 5 supports the tonality as Bb. With the A natural acting as the leading tone and appearing after the Ab, Bb major makes the strongest case for tonal center. The consequent phrase repeats the antecedent phrase but ends on G4 as the piece suddenly modulates to G major. Before continuing to explain the unexpected modulation to G major, the harmonies must be examined.

²⁹ Lerdahl, Tonal Pitch Space, 194.

(a) Basic Space Eb Major

level a :	3		
level b :	3		10
level c :	3	7	10
level d :	0 2 3 5	7 8	10
level e :	0 1 2 3 4 5	6 7 8 9	10 11

(b) Basic Space Bb Major

level a :			10
level b :	5		10
level c :	2 5		10
level d :	0 2 3 5	7 9	10
level e :	0 1 2 3 4 5	6 7 8 9	10 11

Figure 5. *mm. 1-9 analyzed in the Basic Spaces Eb Major and Bb Major*

Same as the melodic content, the harmonies in the piano hide the eventual change to G major but establish Eb major as the prevailing tonality. The chords from the antecedent phrase and consequent phrase are identical until the last two chords where antecedent cadences on Bb major, a half cadence, and the consequent phrase cadences on G major. The harmonic analysis (Musical Example 2) is analyzed in Eb major because, between Bb major and Eb major, Eb major is the best tonal interpretation. The tonal regions (pictured in Figure 6) illustrate the difference in analysis. Eb major is contained within the region but does use secondary dominants. Bb major requires an explanation that uses the F minor region and begins on IV. Lerdahl would prefer Eb major because it relies on only one region, begins on tonic, and ends on the dominant. Interestingly, the

last three chords of the analysis in Bb major resemble a typical structural close (ii - V - I) in Bb major. The last three chords push the listener towards Bb major tonicization.

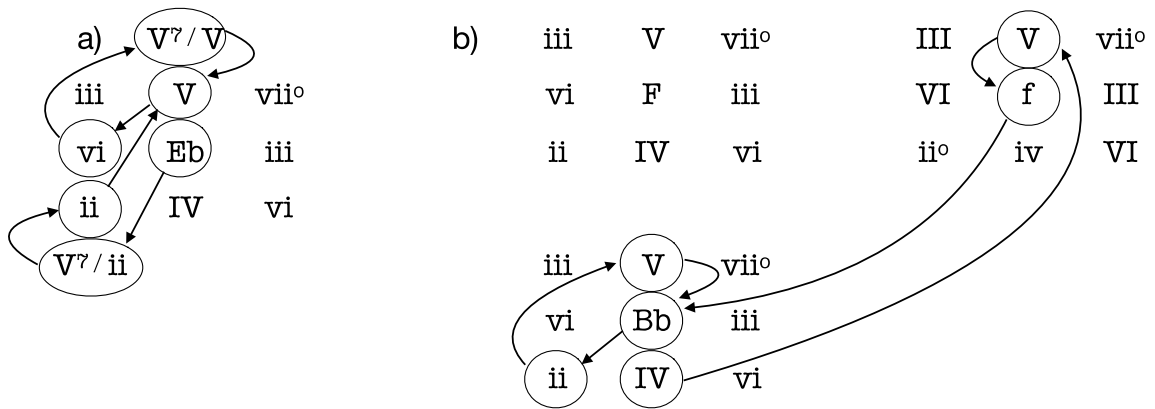

Figure 6. *Tonal Regions (a) Eb major and (b) Bb major with arrows showing harmonic progression*

Eb : I - V⁷/ ii - ii⁶ - V⁷ - vi - V⁷/ V - V⁷

Musical Example 4 Harmonic progression of the antecedent phrase in Roman numerals

In order to analyze the motion to Bb major, three terms must be explained — secondary dominant, tonicization, and modulation. Lerdahl approaches a secondary dominant as a “momentary regional shift”; the resolution of the secondary dominant is under the control of the prevailing key.³⁰ A “tonicization” is a Schenkerian term referring to the “establishment of a diatonic triad as a temporary tonic.”³¹ Modulation is used to

³⁰ Lerdahl, *Tonal Pitch Space*, 59.

³¹ Forte, Allen, and Steven E. Gilbert, *Introduction to Schenkerian Analysis*, (New York: W.W. Norton, 1982), 104.

describe global shifts in region or a change of key. Allen Forte demonstrates the difference between secondary dominants and modulating dominants in Bach’s Chorale No. 298, *Weg, mein Herz, mit den Gedanken* (Musical Example 5). The D major chords in measures 2 and 3 are secondary dominants because the resolution to the dominant is under the control of C major. The D major chord in measure 4 is a modulating dominant because of the “cadential motion II-V-I” in G major.³²

C: I V I [V] P V
G: I II V I

Musical Example 5 Bach, Chorale No. 298, *Weg, mein Herz, mit den Gedanken*³³

The tonal drama in the opening phrases of Schumann’s “Dein Angesicht” may be illustrated using the defined terms — secondary dominant, tonicization, and modulation. The last three chords of the antecedent phrase follow the same “cadential motion” that Forte uses to claim that Bach’s chorale modulates to G major. Instead of modulating, the piece returns to Eb major in the consequent phrase — a tonicization of Bb takes the place of a modulation. The tonicization creates expectations for the end of the consequent phrase. Either the piece needs to modulate fully to Bb major or cadence on Eb major, a

³² Forte, *Introduction to Schenkerian Analysis*, 107.

³³ *Ibid.*, 107. Example 111.

confirmation of one of the two keys present. The ambiguity and expectations arising from the melodic and harmonic content make G major unexpected when the consequent phrase ends with a quick cadence on G major. Furthermore, there is no preparation for G major; a tonicization of Bb ends the antecedent phrase, but a secondary dominant of and resolution to G major ends the consequent phrase. This unexpected modulation to a distant key has a profound impact on the direction of this song — one that will be discussed later. It is the first of two striking features that contribute to the song's interpretation. Next, the second feature will be explained — cadential motion establishing tonal centers and acting as connective material between sections.

9

schmerzenreich. — Und nur die Lip - pen, die sind roth; bald aber küsst sie

G: V⁷ I V⁷ I V⁷ I vii^{0 6}₅/VI
 Ab m: vii^{0 6}₅/V Gr⁺⁶ i⁶₄
 Gb: ii⁶₄

13

bleich der Tod, — er lö - schen wird das Himmels licht das aus den frommen Augen bricht. Dein

Gb: V⁷ I IV ii⁶ V⁷ vii^{0 4}₂
 Eb: ii^{0 4}₂ V⁶₅ 7 4
 2

Musical Example 6 Roman Numeral Analysis of Robert Schumann's "Dein Angesicht"

Op. 127, no. 2, mm. 9-17

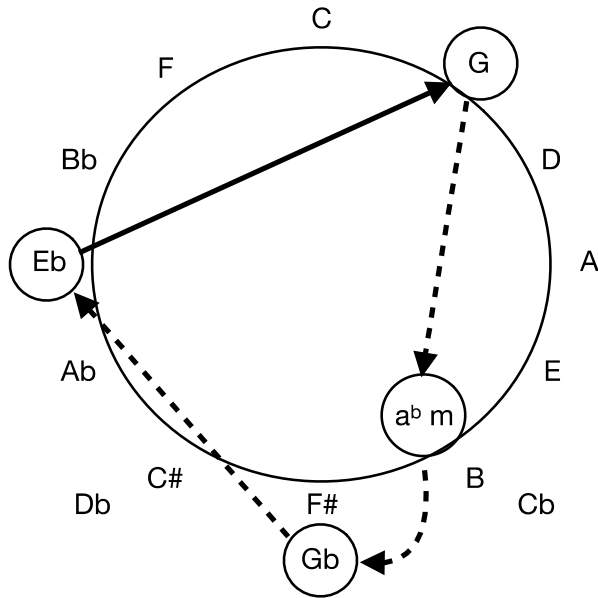

Figure 7. *Diagram of Keys in the B Section of Robert Schumann's "Dein Angesicht"*

The B section of the piece travels through distant keys that are held together by tenuous chromatic connections. As demonstrated in Figure 7, these keys are not close on the circle of fifths, creating the unstable quality of the B section. However, there are subtle connections between the keys allowing for quick modulations. The transition from G major to Gb major is complicated by a brief passage implying Ab minor. G major is established in measures 10-11 by repeating the dominant-to-tonic harmonic motion (V - I) and melodic line (3-2-1: B-A-G) that ends the A section. At the end of measure 11 in Musical Example 5, a fully diminished seventh chord, DFAbCb, begins the suspension of tonality. This chord could resolve to Eb, the original tonic of the piece, or Gb, a key that will be reached in measure 14. An unexpected destination of the chord would be to Ab minor as a new tonic. Schumann is able to allude to Ab minor by lowering the F in the bass voice to Fb, creating the Gr⁺⁶ in Ab minor, and subsequently resolving to a cadential

six-four chord. The cadential six-four chord is reinterpreted as $ii_6/4$ in Gb major, proceeding to a V7 and I in Gb major. Figure 8 illustrates the connections between regions starting in measure 11. Schumann ends the B section with a return to Eb major by exploiting the relative minor of Gb major. Shown with a dotted line in Musical Example 13, $vii^{\circ 7}$ from the key of Gb major is reinterpreted as $ii\emptyset 7$ a modally borrowed chord in Eb major, from the parallel minor. This $ii\emptyset 7$ begins a modally altered cadential motion transitioning the piece back to Eb major.

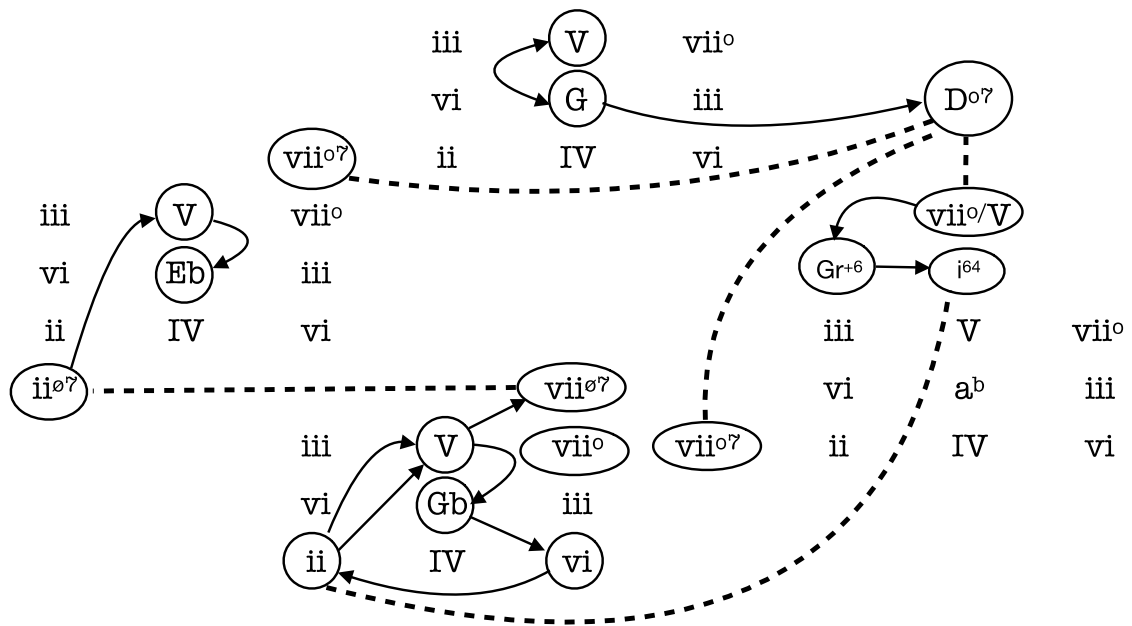

Figure 8. Tonal Regions of “Dein Angesicht’s” B Section

The unstable B section uses familiar elements from the A section to ease the tonal turbulence between G major, Ab minor, Gb major, and the transition back to Eb major. The first familiar element is the repeated use of cadential motion progressions (ii - V - I) which can be heard in regions Eb major and Gb major of Figure 8. Cadential motion was

used throughout the A section of the piece to establish Eb major and Bb major. The second element harmonically emphasizes scale degree six. In the A section, before the vi there is a secondary leading tone chord, but in the B section there are similar secondary diminished chords being utilized in a different way. The D^{o7} chord in top right of Figure 8 could lead to an Eb major chord, a modally borrowed VI in G major, which would mimic the vii^o/vi in the A section. As discussed, the fully diminished seventh chord alludes to Ab minor through emphasis of the dominant. The third element is modulating between chromatic-third related keys. Getting into the B section begins with a sudden change from Eb major to G major, and the B section ends with a transition from Gb major to Eb major via a Bb major chord. Why does the transition from Gb major to Eb major, through Bb major, sound different than Eb major to G major? The answer is in the preparation.

More than the A section, the B section prepares the audience's ear for the A' section's new tonic. In Figure 8, the G major region features only the chords I and V and the Ab minor region never confirms an Ab tonic. Of the keys in the figure, Gb major is the only region in the B section that features Forte's cadential motion, which secures the tonic status of Gb and settles the instability preceding it; Gb major should be expected to continue in measure 17, and a Bb major chord leading back to Eb major should be a surprise. The Ab minor region's chords all allude to an Eb major chord as dominant, but the listener does not receive the Eb major chord because the i6/4 in Ab minor is reinterpreted as a ii^{6/4} pivot chord to Gb major. While allusion to Eb major prepares the listener for the shift back to Eb major in the A prime section, remarkably, an Eb major chord is interpreted as dominant instead of tonic. The modulation to Eb major in the

transition to the A prime section is different than the shift to G major at the end of the A section because Eb major is reached through cadential motion (illustrated in Figure 8).

The allusion to Eb major in the B section and the altered cadential motion in the transition to the A prime section prepare Eb major while G major lacks preparation in the A section.

17

bricht. Dein An - gesicht, so lieb und schön, das hab' ich jüngst im Traum - - - - - geseh'n, es

Eb: I ii $\begin{matrix} 9 & 8 \\ 7 & 6 \end{matrix}$ V⁷ vii⁰⁷/ vi V⁷ / V⁷

22

ist so mild und en - - - - - geteilt, und doch so bleich, so schmer - - - - - zen - - - - - reich.

V⁴/₂ I⁶ V⁴/₂ ii⁰⁶/₅ I⁶/₄ V⁷ I

27

vii⁰⁷ vi ii⁰⁴/₃ I⁶/₄ vii⁰⁷/ V I

Musical Example 7 Roman Numeral Analysis of Robert Schumann’s “Dein Angesicht”
Op. 127, no. 2, mm. 17-31.

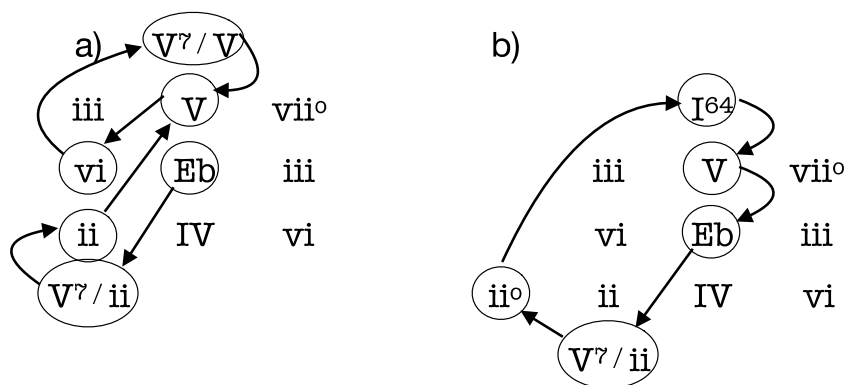

Figure 9. Tonal regions diagram of “Dein Angesicht’s” A’ section (a) mm. 18-21 (b) 22-26

The A prime section of “Dein Angesicht”, measures 18-31 and pictured in Musical Example 7, begins with an exact repetition of the A section’s antecedent phrase and ends with several changes to the consequent phrase including the striking reinterpretation of an important motive: modally-altered cadential motion. Figure 9 shows the contrasting period in a tonal regions diagram. The consequent phrase (b) follows what the listener expects from the antecedent phrase (a); the piece ends in Eb major, one of two options set up by the antecedent phrase. Even though the consequent phrase cadences in Eb major, the cadential motion to Eb major features a borrowed chord, ii^{ø6/5}. Seen in Figure 8, the borrowed chord comes from the end of the B section — serving as the connection between Eb major and Gb major regions — which explains the purpose of this modal alteration.

The analysis set out to explain two features of the piece: a surprising change in tonality, and a cadential motion that gains motivic significance before it is reinterpreted through modal borrowing. The A section’s melodic and harmonic content reside in Eb major making the tonal shift to G major startling. During the piece, cadential motion (ii -

V - I) is used to establish tonal centers and acts as connective material between sections. In the A prime section, the cadential motion changes as the result of a modally-borrowed half-diminished seventh chord. A theoretical explanation of the lied has revealed the striking features occurring from tonal expectations. These features are paired with critical moments in Heinrich Heine’s poem.

	A	B	A	
	Eb Major m. 1-9	G Major m. 9-11	Gb Major m. 12-17	Eb Major m. 18-31
Eb:	I – V I – III	III	bIII – V	I – V ii ^{o7} – V – I
	Text describes the poet’s love.	The love is dying.	Repeated text from A, but the love is dead.	

Musical Example 8 Form Diagram of Schumann’s “Dein Angesicht” with Poetic Plot

In Schumann’s “Dein Angesicht”, represented in Musical Example 8, the musical narrative and poetic plot mirror each other with a sudden shift in the expectations that began this work and a resolution to the beginning with a change. The best label for “Dein Angesicht” is irony. Almén describes irony as the defeat of order — the expectations of order will not be met. Based on the initial phrase, order establishes the expectation of Eb major. The piece ends in Eb major, but the iio from the parallel minor references the tonal region of Gb major: the relative major and the final tonal region of the B section of the piece. The final cadence in Eb major carries great weight as the previous cadences emphasized Bb major, G major, and Gb major. Instead of cadencing using only chords from the Eb major region, it sneaks the ii^o. Order prevails but not completely victorious. In the text, Schumann adds a repeat of the opening stanza, but now the listener carries the knowledge of the love’s looming death. This knowledge changes the perspective from

which the audience hears the repeated stanza — admiration becomes mourning. These elements represent defeat. If the final cadence in Eb major represents a victory of order, then it is a victory tinged with irony and a changed perspective. Now the lied may be described as having a rounded binary form with an irony musical narrative.

CHAPTER IV – JOHANNES BRAHMS’S “DER KRANZ” OP. 84, NO. 2

Johannes Brahms’s “Der Kranz” Op. 84, no. 2, comes from a collection of songs titled “Romanzen und Lieder” Op. 84 composed in 1882 during Brahms’s late period in Vienna.³⁴ Hans Schmidt was the poet of “Der Kranz” which originally appeared in *Gedichte und Übersetzungen*. The only addition Brahms makes to the poem are the words “Mother” and “Daughter” which are not meant to be sung: they only clarify the character of each stanza.

Daughter

Mutter, hilf mir armen Tochter,
Sieh' nur, was ein Knabe tat:
Einen Kranz von Rosen flocht er,
Den er mich zu tragen bat!

Mother

Ei, sei deshalb unerschrocken,
Helfen läßt sich dir gewiß!
Nimm den Kranz nur aus den Locken,
Und den Knaben, den vergiß!

Daughter

Dornen hat der Kranz, o Mutter,
Und die halten fest das Haar!
Worte sprach der Knabe, Mutter,
an die denk' ich immerdar!

Daughter

Mother, help me, your poor daughter,
Look at what some boy has done:
He's woven a wreath of roses,
which he told me to wear!

Mother

Ah, don't be frightened by that;
it can certainly be helped!
Just remove the wreath from your hair,
and the boy: forget him!

Daughter

The wreath has thorns, o Mother,
And they're holding tightly to my hair!
The boy spoke some words, Mother,
and I keep thinking of them!

Musical Example 9 Hans Schmidt’s Poem “Der Kranz”³⁵

³⁴ Bozarth, George S., and Walter Frisch, “Johannes Brahms”, Oxford Music Online, (Oxford: Oxford University, 2001).

³⁵ Eric, Sams, *The Songs of Johannes Brahms* (New Haven: Yale University Press, 2000), 247-8.

Schmidt's "Der Kranz" features a straightforward plot requiring deeper examination to understand the complexity. In the opening stanza, the daughter comes to the mother complaining about a wreath that a boy has given her. The mother responds in the second stanza by telling the daughter not to worry, throw the wreath away, and forget the boy. In the final stanza, the daughter restates that the thorns on the wreath are hurting her, but the boy told her some words that she continues to think about. Based on the surface level of text reading, it is unclear whether the girl viewed the wreath in a negative or positive light, but insights from Eric Sams clarify this conflict.

Sams reveals the complex nature of the poem by explaining the symbolic wreath. The wreath given to the daughter by the boy could be a marriage proposal.³⁶ Before understanding the symbol for marriage, the wreath appeared to cause the daughter physical pain. Now the first stanza shows the daughter's indecision on whether or not to accept the offer. The idea of marriage further clarifies the final stanza when the daughter states that she continues to think of the words the boy told her, his proposal. The daughter comes to her mother with a decision to make, the mother suggests she forget the boy, and the daughter decides to keep the wreath. Brahms is able to capture this conflict in his musical setting of Schmidt's "Der Kranz" primarily with his manipulation of tonality.

	A	B	A
	G minor m. 1-16	D major/minor m. 17-27	G minor, then major m. 28-32
g:	i – V V – III III ... i	V – v	i – I

Musical Example 10 A Form Diagram of Johannes Brahms's "Der Kranz" Op. 84, no. 2

³⁶ Eric, Sams, *The Songs of Johannes Brahms* (New Haven: Yale University Press, 2000), 248.

Johannes Brahms's "Der Kranz" Op. 84, no. 2, has a rounded binary form (shown in Musical Example 10) with striking tonal ambiguity heard early in the piece between the keys of G minor, D major, and Bb major. The tonality is not confirmed until the end of the piece when it settles in G major. Ultimately, the tonal evolution from ambiguity to confirmation follows the poetic narrative of "Der Kranz". Before analyzing the musical narrative, this thesis analyzes the piece using Lerdahl's concepts to understand Brahms's use of tonal stability.

The image shows a musical score for Johannes Brahms's "Der Kranz" Op. 84, no. 2, measures 1-6. It features a voice line and a piano accompaniment. The voice part has the lyrics: "Mut - ter, hilf mir ar - men Toch - ter, sieh nur, was ein Kna - be tat:". Below the piano part, Roman numeral analysis is provided: g: V V i i III ii V.

Musical Example 11 Roman Numeral Analysis of Johannes Brahm's "Der Kranz"

Op. 84, no. 2, mm. 1-6

In the A section of "Der Kranz", tonal uncertainty is created by harmonies in the piano and the melodic content of the voice, such that none of the consonant triads of the opening phrase — Bb major, D major, nor G minor — make a convincing case for

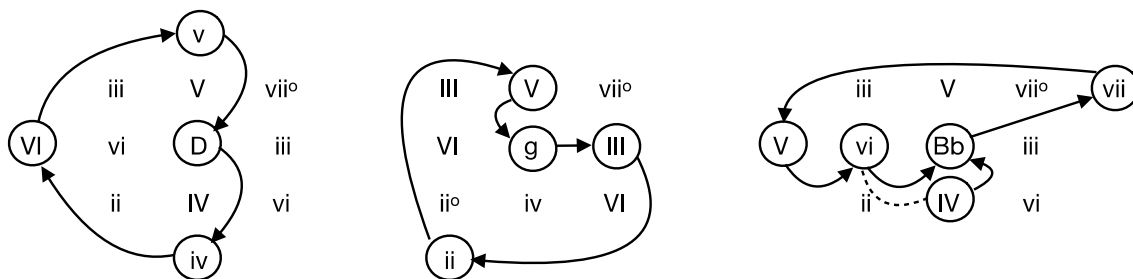

Figure 11. *Regions D major, G minor, and Bb major in “Der Kranz” mm. 1-6*

Similar to the melodic content, the harmonies from the beginning six measures add to the tonal uncertainty with a lack of cadential motion in any possible region: Bb major, D major, or G minor. During the first phrase, the piano has multiple non-chord tones that decorate the progression: V - i - III - ii - V. Eb’s appear in the same measure as G minor, giving the chord the possibility of being heard as an Eb major or G minor chord with non-chord tones. In Figure 11, this conflicting possibility is shown by a dotted line connecting vi and IV in the Bb region. A less preferred option by Lerdahl’s standards, but by the end of the A section the piece will feature cadential motion in Bb major. D major chords beginning and ending the opening six measures could be understood as tonic, but the use of three borrowed chords to justify the region is not a strong interpretation. The best region for the opening section is G minor, but even this region requires borrowed chords, see the ii in the G minor region of Figure 11. The possibility of three different regions and no cadential motion in any region create instability in the opening phrase.

7

ei - nen Kranz von Ro - sen - flocht er, den er

g: V V iv III

11

mich zu tra - gen bat, mich zu tra - gen bat!

g: III v⁷ / v⁷ / III

Bb: I v⁷ / v⁷ I

Musical Example 12 Roman Numeral Analysis of Johannes Brahms's "Der Kranz"

Op. 84, no. 2, mm. 7-15

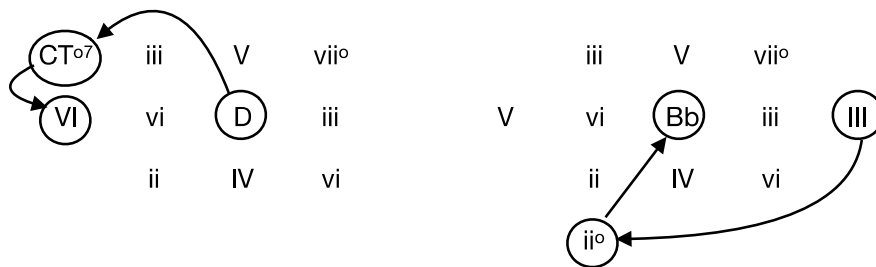

Figure 12. Regions D major and Bb major from "Der Kranz" mm. 7-12

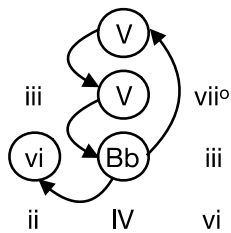

Figure 13. *Region Bb major in “Der Kranz” mm. 13-16*

The second phrase of the A section, measures 8-16 shown in Musical Example 12, makes a concerted effort to confirm Bb major as the tonal base. Beginning with the III chord in measure 10, the harmonies would be better analyzed in Bb major, as opposed to G minor. Figures 12 and 13 demonstrate how, in measures 7-12, there is still a lack of regional stability, but in measures 13-16, Bb major becomes the only option. The melody begins in the same vein as the first phrase, tonally centered on D, by leaping from A4 up to D5. The difference in this phrase is that the melody conforms to Bb major emphasizing Bb's and F's, as do the harmonies — finally giving the piece stability. The emergence of Bb raises questions about the intended tonality of the piece. If Bb major was intended tonally, and the one G minor chord is meant to be a vi or IV with the inclusion of Eb, why are there so many D major chords? D major could be used as a secondary dominant of vi, a G minor chord, but not every D chord goes to G minor. Bb major has created stability, but does not retroactively answer any questions. The stability of Bb major is a fleeting moment as the next section predominantly features D major and minor.

16

Ei, sei des - halb un - er - schro - cken, hel - fen läßt sich

g: i V V V V

21

dir ge - wiß! Nimm den Kranz nur aus den Lo - cken, und den Kna - ben,

g: V / V d: ii⁶/₅ V ii⁶/₅ V i

D: I I I I

25

den ver - giß, den Kna - ben, den ver - biß!

d: ii⁶/₅ V i VI ii⁶/₅ V i

Musical Example 13 Roman Numeral Analysis of Johannes Brahms's "Der Kranz"

Op. 84, no. 2, mm. 16-28

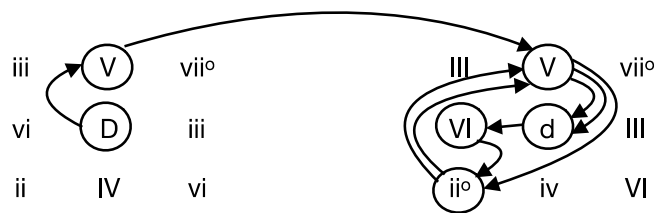

Figure 14. Regions D major and D minor in "Der Kranz" mm. 17-28

The B section of “Der Kranz” (Musical Example 13) spans measures 17-28 and shifts from D major to D minor, but both tonal areas are stable. In measure 16, a G minor chord is used as a transition between the Bb major in measure 15 and the D major in measure 17. This use of G minor is consistent with the beginning of the piece — Bb major and D major were connected by G minor, but G minor does not control the tonality. Measures 17-21 all support D major as the tonal center with A and D major chords. During this section, the voice conforms to D major, ridding itself of Eb’s and Bb’s while adding F#’s. In measure 22, the Bb’s and F’s return, moving the piece to D minor and adding cadential motion to confirm D minor, the strongest cadential confirmation thus far. (Figure 14 illustrates the consistent use of the ii-V-I cadential motion in D minor.) At the end of the A section, Bb major follows cadential motion with a secondary dominant replacing the usual ii chord. The stability of the B section is a welcome contrast to the unstable A section. When the piece returns to the A section, will the harmony regain its uncertainty?

29

Dor - nen hat der Kranz, — o Mut - ter,

g: V V i i III

33

und die hal - ten fest — das Haar!

g: ii V V⁷

36

Wor - - te sprach — der Kna - be, Mut - ter Mut - ter,

G: I ii V V

Musical Example 14 Roman Numeral Analysis of Johannes Brahms's "Der Kranz"

Op. 84, no. 2, mm. 29-39

40

an die denk ich im mer - dar

G: vii°_3 I^6 $V^7 /$ V $V^7 /$ vi

44

an die denk ich im mer - dar!

G: vii I $V^7 /$ V^7 I

48

G: I I

Musical Example 15 Roman Numeral Analysis of Johannes Brahms's "Der Kranz"

Op. 84, no. 2, mm. 40-50

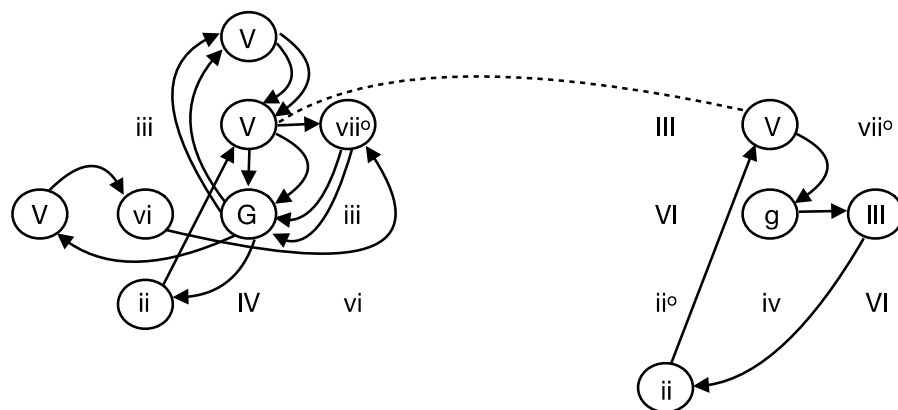

Figure 15. Regions G major and G minor in "Der Kranz" mm. 29-50

The A prime section of the piece (Musical Examples 14 and 15) begins the same as the opening section, but the once-ambiguous G minor is later replaced with a convincing G major tonality. Measures 29-35 are mostly a repetition of the opening six measures, but with the melody beginning and ending on D5 and the presence of a V⁷, the music sounds more centered on G. In measure 36, there is a key change from G minor to G major with the dominant being used as a connector (dotted line in Figure 15); however, G major does not immediately seize complete control. In measures 36, 38, and 39, common-tone diminished seventh chords delay the expected harmony. Compared to the original A section, the A prime section contains more tonic chords and remains relatively within one region. Seen in the Lerdahl analysis of the section, the cadential motion that became prominent in the B section only happens once in the A prime section, but there are plenty of dominant functioning chords that emphasize G major as tonic. The section ends with the voice landing on G4 and the piano repeating G major chords during the final three measures. The closing of the piece is the antithesis of the beginning, ending with stable G major.

	A	B	A
	G minor m. 1-16	D major/minor m. 17-27	G minor, then major m. 28-32
g :	i – V V – III III ... i	V – v	i – I
	The daughter is in pain because of the boy's wreath.	The mother tells her not to wear it.	The daughter decides to wear the wreath.

Musical Example 16 Form Diagram of Brahms's "Der Kranz" with Poetic Plot

Similar to the analysis of Schumann's "Dein Angesicht," In Brahms's "Der Kranz" the musical narrative is reflective of the poetic plot, seen in Musical Example 16. The piece begins with tonal ambiguity, the order of the piece. The transgression is represented by tonal stability, which the listener receives beginning in the B section with D major and minor. The music ends with G major triumphing over the tonal ambiguity. The audience wants G major, because the harmonic expectations lead us to believe that a tonal region around G is preferred. The indecisiveness of the daughter is represented in the tonal ambiguity (order), the mother's advice is represented by tonal stability (transgression), and the daughter's decision is characterized by tonal stability (transgression) in G major. The best archetype for this piece is comedy — the victory of the transgression. The piece may be described as a lied in rounded binary form with a comedy musical narrative.

The comedic narrative relies on the transgression of the piece being preferred. The A section establishes the order because it is the first music the listener hears. In the A section, D major, Bb major, and G minor are present. Melodically D major is emphasized in the first phrase and Bb major in the second phrase. By the end of the A section, the piece appears to be modulating to Bb major but slips into D major via a G minor chord, an unconvincing modulation because of the regressive harmonic motion (D: bIV – iv – I). In the B section, the melodic content and the harmonic content both center around D, first major and then minor. D minor is more appealing to the listener because of the cadential motion. Until the latter part of the B section, there is little cadential motion leading the listener to distrust any tonality that may surface. The A' section begins with a repetition of the opening six measures but adds a D⁷ chord in a seventh measure to

modulate the piece to G major. Common-tone fully diminished seven chords delay G major, but the section ends with a perfect authentic cadence. The delay of tonal confirmation is important because it allows the listener time to anticipate. The initial tonal ambiguity of the piece, the gradual expectation of tonal stability, and finally achieving tonal stability in G major defines the comedy narrative — the victory of the transgression.

CHAPTER V – GABRIEL FAURÉ'S "HYMNE" OP. 7, NO. 2

À la très chère, à la très belle, Qui remplit mon cœur de clarté, À l'ange, à l'idole immortelle, Salut en immortalité, Salut en immortalité!	To the dearest one, the fairest one, Who fills my heart with light, To the angel, the immortal idol, I pledge undying love, I pledge undying love!
Elle se répand dans ma vie, Comme un air imprégné de sel, Et dans mon âme inassouvie, Verse le goût de l'Eternel.	She pervades my life Like a salt-filled breeze, And into my unsatisfied soul Pours the taste of the eternal.
Comment, amour incorruptible, T'exprimer avec vérité? Grain de musc, qui gît invisible, Au fond de mon éternité!	How, incorruptible love, Can I express you faithfully? Grain of musk, lying unseen In the depths of my eternity!
À la très chère, à la très-belle, Qui remplit mon cœur de clarté, À l'ange, à l'idole immortelle, Salut en immortalité, Salut en immortalité!	To the dearest one, the fairest one, Who fills my heart with light, To the angel, the immortal idol, I pledge undying love, I pledge undying love!thinking of them!

Musical Example 17 Claude Baudelaire's poem "Hymne"³⁷

Gabriel Fauré's "Hymne" Op. 7, no. 2, set to the poetry by Claude Baudelaire and dedicated to Félix Lévy, was composed in 1870 and represents Fauré's early style.

"Hymne" would later join "Après une rêve" and "Barcarolle" in Fauré's Op. 7 "Trois melodies."³⁸ The original poem contains five stanzas, but stanza three was removed in Fauré's setting, and the fifth stanza is a repetition of the first. The original third and fifth stanzas with translations are provided in Musical Example 18.

³⁷ Graham, Johnson, *Gabriel Fauré: The songs and their poets*, Richard Stokes trans. (Famfam: Ashgate, 2009) 70.

³⁸ Jean-Michel, Nectoux, "Gabriel Fauré", In *New Grove Dictionary of Music and Musicians*, ed. Stanley Sadie, (Oxford: Oxford University Press, 2001).

Sachet toujours frais qui parfume L'atmosphère d'un cher réduit, Encensoir oublié qui fume En secret à travers la nuit,	Sachet, ever fresh, that perfumes The atmosphere of a dear nook, Forgotten censer smoldering Secretly through the night,
À la très bonne, à la très belle Qui fait ma joie et ma santé, À l'ange, à l'idole immortelle, Salut en l'immortalité!	To the dearest, fairest woman Who is my health and my delight To the angel, the immortal idol, Greetings in immortality!

Musical Example 18 Stanza's Three and Five to Baudelaire's "Hymne"

Claude Baudelaire's poem "Hymne" passionately expresses his faithfulness to his beloved. In the opening stanza, Baudelaire pledges his undying love. The second stanza describes how this woman permeates through the poet's life and provides anything he needs. The third stanza, omitted by Fauré, describes the always pleasant aroma of the woman. The fourth stanza questions how the poet can remain faithful. In response to the doubt of the fourth stanza, the closing stanza exclaims that the poet will be faithful saluting immortality.³⁹

Graham Johnson disagrees with Fauré's musical setting, finding it underwhelming compared to the text and "the poet's passionate sentiments."⁴⁰ First Johnson points to the "gentle tremolos" in the piano that are too subtle for the grand concepts Baudelaire uses. Second, Johnson would have preferred the inclusion of the third stanza and no alteration to the final stanza.⁴¹ The third stanza does prove important with its description of the

³⁹ Charles, Baudelaire, "Hymne," trans. William Aggeler, Roy Campbell, Jacques LeClercq, Eli Siegel, Lewis Piaget Shanks, Geoffrey Wagner, <https://fleursdumal.org>.

⁴⁰ Johnson, Gabriel Fauré, 70.

⁴¹ Ibid. 70.

beloved's perfume, fresh and atmospheric, that is contrasted by the "grain of musk" in the fourth stanza. Symbolically Baudelaire uses "grain of musk" in the fourth stanza to question his loyalty. The woman's perfume should permeate completely throughout the room but the grain of musk remains; the perfect woman should be enough for Baudelaire, but something remains making him doubt his loyalty. The alteration in the final stanza is to the second line but ultimately remains the same sentiment. In contrast to Johnson's first issue, Fauré musically captures the essence of Baudelaire's poem with his manipulation of tonality. This thesis analyzes Fauré's "Hymne" demonstrating how tonality can be used to faithfully express Baudelaire's immortal devotion.

	A	B			A
	G major m. 1-18	C major m. 19-27	G Major and B major m. 28-44	D major 45-52	G major m. 53-76
G:	I – I	IV	III	V	I – I

Musical Example 19 Form Diagram of Fauré's "Hymne"

unequivocally in G Major. By using Lerdahl's analytical techniques, there will be common ground to compare the pieces and discuss the implications of tonal expectations.

The image displays a musical score for Gabriel Fauré's "Hymne" Op. 7, no. 2, measures 1-8. It features a voice line and a piano accompaniment. The key signature is G major (one sharp) and the time signature is 6/8. The piano part begins with a piano (*p*) dynamic. The voice part has lyrics in French. Below the score, Roman numeral analyses are provided for both the G major and E minor keys.

Chords in G Major:

G:	I		I	vi	V / vi
			e:	i	V

Chords in E Minor:

G:	V^6 / IV	V^4 / IV	IV	VI	V / vi	VI	V / ii
E:	I	V	I	V	I	V / iv	

Musical Example 20 Roman Numeral Analysis of Gabriel Fauré's "Hymne" Op. 7, no. 2, mm. 1-8

There are several elements in the opening phrase of the A section (Musical Example 20) that establish G major as tonic. The phrase encompasses measures 1-8 with the harmonies supporting G major with chords: I - vi - I - IV in measures 1-5. In measure 4, there is a B major chord that is best explained as the dominant of E minor but does not resolve to an E minor chord. Perhaps this brief modulation was a precursor to the end of the phrase where E major arrives in measure 7. Similar to Brahms's "Der Kranz", the

opening phrase is open to interpretation, but in contrast “Hymne” is relatively stable in G major, with three measures of G major chords beginning the piece, until the last two measures where E major takes over. The melody begins with a linear chromatic ascent to begin the phrase, but starting in measure 5, the voice moves by step and skips conforming to G major. The melody ends on B4 which is shared between G major and the new E major. The phrase ends with a $V^{4/2}$ of A minor; however, as shown in the next example, there are different tonalities that require consideration. G major is the best key for analysis in the opening phrase. E major may end the phrase, but there is no cadential motion used to establish E major resulting in a brief tonicization instead of a modulation.

9 À l'ange, à l'i-dole im - mor - tel - le, Sa - lut

9 G: ii⁶ V⁶ / ii V I⁶ V I V / ii
 E: iv⁶ I⁶ iv V / iv
 a: i⁶ V⁶ i V

14 — en im - mor - ta - li - té, Sa - lut en im - mor - ta - li - té!

14 G: V I V / IV

Musical Example 21 Roman Numeral Analysis of Gabriel Fauré’s “Hymne” Op. 7, no. 2, mm. 9-18

The second phrase of the A section (Musical Example 21) follows the same theme as the first — while there are other keys present, G major remains the best key for analysis. To start the phrase, G major, E major, and A minor are all possibilities in measure 9. The use of G#4 in measure 10 suggests that A minor is the strongest contender. Analogous to E major in the first phrase, A minor does not last more than a few measures. In measure 11, there are D and G major chords that prevent the piece from modulating. As a method of disrupting the tonality, an E major chord is used in measure 13, but the following chord is D major. In the piano part, the use of F natural in favor of F# in measure 16, our tonic in G major becomes the dominant of C major, possibly nothing more than a secondary dominant as most of the other deviations have been. The answer is revealed in the B section.

G major is the tonality of the A section, both melodically and harmonically; however, the melody has an aversion to the pitch G. All of the G's in the voice amount rhythmically to 7 eighth notes. Another notable feature is the absence of a cadence in G major. The first phrase ends on E major, while the end of the second phrase slips into C major preparing the start of the B section.

19

El - le se ré - pand dans ma vi - e

19

pp

G: IV IV IV IV

C: I I I I

24

Comme un air im - pré - gné de sel

24

G: IV IV IV V

C: I I I

Musical Example 22 Roman Numeral Analysis of Gabriel Fauré, “Hymne” Op. 7, no. 2, mm. 19-27

The first phrase of the B section is primarily in C major (Musical Example 22), although there is no cadential motion that confirms or denies the harmonic center of C major. If this section was graphed using Lerdahl’s basic space, there are two notes that would determine the basic space — F# and F natural. In measure 22, the voice alters the F# to F natural encouraging the shift to C major, but in measure 26 F# reappears in the voice, spurring the piano to change the harmony to a D major chord. Illustrated in the Roman numerals of Musical Example 2w, the entire phrase could be in C major, but could also be explained in G major as a prolongation of the subdominant, which

ultimately moves to the dominant. Interestingly, the pitch G4 is held for the duration of a dotted quarter note in the voice — the longest duration throughout the piece thus far. The G4 appears on beat 2 and is approached by an appoggiatura in measure 23. While this phrase contains the longest G4 in the piece so far, the piece has not cadenced with the voice singing G4.

28 Et dans mon âme in - as - sou - vi - e,

28 Ver - se le goût de l'É - ter - nel. Com -

G: V iv⁷ iv⁷ I

G: bVI I⁶₄ vi VII

B: VI iv V

Musical Example 23 Roman Numeral Analysis of Gabriel Fauré's "Hymne" Op. 7, no. 2, mm. 28-36

The second phrase of the B section flirts with a return to G major, keeping the opening tonic close, but transitions to B major. Heard in Musical Example 23, there are hints of G major again, the dominant begins the phrase, but in the second measure of the phrase, a C minor seven chord appears — lasting for two measures before moving to a G major chord in measure 31. This harmonic embellishment helps to destabilize G major in addition to the Eb's and F naturals appearing melodically in measures 29 and 30. Melodically measures 31-36 better fit the basic space of G major rather than B major, but the phrase ends melodically on F#4 and harmonically on an F# major chord, suggesting B major or minor. Again, during the phrase, the melody seems to intentionally avoid G — the pitch G has yet to be articulated on the first beat of a given measure and in total rhythmic value the pitch G is sung a little more than four beats in the thirty-six measures thus far. While G major never appears far away from the listener's ear, the absence of the melodic pitch G is curious.

and the left hand begin on F# and ascend their way up to B. The right hand repeats this pattern starting at measure 41 before the bass has reached B. Beginning and ending on F# and B respectively helps establish B major by focusing on scale degrees 5 and 1. In measure 42, the piano plays the notes B, D#, and A — enharmonically Cb, Eb, and A forming an Italian augmented sixth chord in Eb. In measure 43, the piano resolves to I6/4, but instead of moving to a Bb major chord, the dominant of Eb, German augmented sixth chord from G major appears. The two augmented chords allow the piece to quickly move from B major through Eb major back to G major. Throughout this phrase, the melody does not feature any G's.

45
muse, qui gis in - vi - si - ble, Au

45
fond, de mon é - ter - ni - té?

G: I⁴ 6

G: V

Musical Example 25 Roman Numeral Analysis of Gabriel Fauré's "Hymne" Op. 7, no. 2, mm. 45-52

In the final phrase of the B section (Musical Example 25), both the melody and the harmony make a decisive effort to return to G major. Melodically all of the pitches in the voice are from the G major basic space, and, harmonically, $I^{6/4}$ and V act as dominant prolongations in the key of G major. The chromatic ascent in the piano, originally F# up to B in the third phrase of the B section, now appears from D up to G, emphasizing the return of G major. As the dominant prolongation prepares the listener for G major, the melody continues to hint at G but never reaches its destination. Starting in measure 45 of Musical Example 25, the voice descends stepwise from B4 to G4 and repeats the pitches with an appoggiatura skipping to F#4 before reaching G4. The phrase ends melodically on D5 and G4's total rhythmic value is only one beat. Contrasting the other analyses, tonal centers are not where the drama in this analysis lies — reaching G4 melodically on a downbeat is the goal.

53

À la très chère, à la très belle,

G: V I vi V / vi
e: i V

57 *mf*

Qui remplit mon cœur de clarté,

G: V⁴ / IV V⁴ / IV IV III V / III V /
E: I V I V /

Musical Example 26 Roman Numeral Analysis of Gabriel Fauré's "Hymne" Op. 7, no. 2, mm. 53-60

61

À l'ange, à l'i - dole im - mor - tel - - - le,

G: ii V / ii V I V
 E: iv V / iv
 a: i V i

65

Sa - lut en im - mor - ta - li - té, Sa - lut en im - mor - ta - li -

G: I V / ii V I V / IV
 E: V / iv C: V
 a: V

Musical Example 27 Roman Numeral Analysis of Gabriel Fauré's "Hymne" Op. 7, no. 2, mm. 61-68

69 *f*
 tél Sa - - - lut en im-mor - ta - li - tél
 69
 G: IV vii I⁶/₄ V I
 C: I

74
 74
 G: I

Musical Example 28 Roman Numeral Analysis of Gabriel Fauré's "Hymne" Op. 7, no. 2, mm. 69-76

In the A' section of "Hymne" (Musical Examples 26-28), Fauré yields his avoidance of G4, allowing the voice to rest on G4 on the downbeat of measure 73, an achievement heralded by a perfect authentic cadence in the piano. In addition to the G4 in measure 73 of Musical Example 28, there is a G5 sung on the downbeat of measure 70 over a vii. The G's both being sung on the downbeat of their respective measures and being held for the entirety of the measure relieve the tension built during the piece. G4 carries more importance being sung with a PAC opposed to vii. Fauré has dramatized the melody in a piece where G major never completely disappears. We turn our attention to

the text by Charles Baudelaire to examine the relationship between musical and textual drama.

The eternal love of the poet is represented by G major being present for the majority of the piece, but the piece is not without conflict. Melodically G4 is avoided throughout, being reserved for the final moments of the piece. Harmonically a perfect authentic cadence is saved for the ending of the piece as well. These elements punctuate G major just as the poet emphasizes his love with an extra “Salut en immortalité” in the final stanza. The best archetype to describe the piece is romance, the victory of order. In this *mélodie*, G major represents order, while the transgression is the aversion to G4 melodically and PAC’s harmonically. By the end of the piece, G major is victorious over the transgressions. Fauré’s “Hymne” is described as rounded binary with a romance musical narrative.

Again, the musical narrative of the piece is reliant on the order or start to the piece. The piece begins firmly in G major even with secondary dominants and chromaticism in the melodic line. The missing piece from the A section is a perfect authentic cadence. The search for an authentic cadence drives the listener through the rest of the piece. The B section of the piece explores many keys — C, B, and D major — but all lack cadences to establish a new tonic. The missing cadences leave the listener unconvinced of the modulations. The A’ section is an exact repeat of the A section until measure 70 where the voice reaches up to G5. Three measures later, the piece finally completes a perfect authentic cadence in G major. The order of the piece is never truly questioned by the listener, but the piece is not without transgressions. The avoidance of G melodically and the lack of a perfect authentic cadence in G major represent the

transgressions. Ultimately, order is victorious over the transgressions resulting in the formation of the romantic narrative.

In conclusion, the works used in this thesis were analyzed using Lerdahl's approach and from that analysis striking musical features arose. These features were then tracked throughout the pieces and categorized as elements of the transgression or of the order-imposing hierarchy. Finally, the pieces were categorized as having a musical narrative, romance, tragedy, comedy, or irony, based on the interactions between the transgression and order-imposing hierarchy. The narrative archetypes are metaphors illustrating musical expectations — a feature deserving more emphasis in music theory

WORKS CITED

- Agawu, Kofi. "A Theory of Musical Narrative". *Notes* 66.2 (December 2009): 277.
- Almén, Byron. *A Theory of Musical Narrative*. (Bloomington: Indiana University, 2008).
- Binder, Benjamin. "Robert, Clara and the Transformation of Poetic Irony in Schumann's Lieder: The Case of 'Dein Angesicht,'" *Nineteenth-Century Music Review* 10 (Cambridge, MA: Cambridge University Press, 2013).
- Bozarth, George S. and Walter Frisch, "Johannes Brahms". *Oxford Music Online*. (Oxford: Oxford University, 2001).
- Daverio, John, and Eric Sams. "Robert Schumann". *Oxford Music Online*. (Oxford: Oxford University, 2001).
- Ezust, Emily. "Dein Angesicht". www.lieder.net (accessed August 2017).
- _____. "Der Kranz", www.lieder.net (Accessed August 2017).
- Forte, Allen, and Steven E. Gilbert. *Introduction to Schenkerian Analysis*. (New York: W.W. Norton, 1982).
- Frye, Northrop. *Anatomy of Criticism: Four Essays*. (Princeton, N.J.: Princeton University Press, 1957).
- Johnson, Graham. *Gabriel Fauré: The Songs and Their Poets*. Richard Stokes trans. (Famfam: Ashgate, 2009).
- Klein, Michael. "Chopin's Fourth Ballade as Musical Narrative". *Music Theory Spectrum* 26.1 (Spring 2004): 23-56.
- Laitz, Steven G. *The Complete Musician: An Integrated Approach to Tonal Theory, Analysis, and Listening*. 3rd edition. (Oxford: Oxford University Press, 2012).
- Lerdahl, Fred. *Tonal Pitch Space*. (Oxford: Oxford University Press, 2004).
- Lizska, James. *The Semiotic of Myth: A Critical Study of the Symbol*. (Bloomington: Indiana University Press, 1989).
- Maus, Fred E. "Narratology" In *New Grove Dictionary of Music and Musicians*, ed. Stanley Sadie. (Oxford: Oxford University, 2001).

- Miller, Richard. *Singing Schumann: An Interpretive Guide for Performers*. (Oxford: Oxford University, 2005).
- Monahan, Seth. "Action and Agency Revisited" *Journal of Music Theory* 57.2 (Fall 2013): 321-71.
- Nectoux, Jean-Michel. "Gabriel Fauré". In *New Grove Dictionary of Music and Musicians*, ed. Stanley Sadie, (Oxford: Oxford University Press, 2001).
- Sams, Eric. *The Songs of Johannes Brahms*. (New Haven: Yale University Press, 2000).
- _____. *The Songs of Robert Schumann*. (London: Faber and Faber Ltd., 2011).
- Seaton, Douglass. "A Theory of Musical Narrative." *Journal of Musicological Research* 30 (2011) 72.
- Whittall, Arnold. "A Theory of Musical Narrative" *Music and Letters* 91.2 (May 2010) 300.