

NUMERICAL SIMULATION OF PARTIALLY PREMIXED COMBUSTION USING A FLAME SURFACE DENSITY APPROACH

Ezequiel J. López^a, Horacio J. Aguerre^b, César I. Pairetti^c and Norberto M. Nigro^b

^a*Instituto de Investigación en Tecnologías y Ciencias de la Ingeniería, Universidad Nacional del Comahue-CONICET, Buenos Aires 1400, 8300 Neuquén, Argentina
ezequiel.lopez@fain.uncoma.edu.ar*

^b*Centro de Investigación en Métodos Computacionales, Universidad Nacional del Litoral-CONICET, Predio CONICET “Dr. Alberto Cassano”, Colectora RN 168 s/n – Paraje El Pozo, 3000 Santa Fe, Argentina
aguerrehoracio@gmail.com, norberto.nigro@cimec.santafe-conicet.gov.ar*

^c*Escuela de Ingeniería Mecánica, Facultad de Ciencias Exactas, Ingeniería y Agrimensura Universidad Nacional de Rosario, Berutti 2109, 2000 Rosario, Argentina
paire.cesar@gmail.com*

Keywords: Partially premixed turbulent combustion, Flame Surface Density, Mixture fraction, DISI engine combustion, OpenFOAM[®].

Abstract. Partially premixed combustion is characterized by a variable equivalence ratio of the mixture in space and time, and where there are both lean and rich mixture zones. Thus the reaction evolves along with a turbulent mixture process, which modifies the composition of reactants and products. In this situation a so-called triple flame could be encountered, in which a rich and a lean premixed flame front as well as a diffusion flame are present. The diffusion flame develops behind the premixed flame front due to turbulent mixing in the hot combustion products. This kind of combustion could be found in Direct Injection Spark Ignition (DISI) engines when they are operated in the stratified charge mode. The model considered in this work assumes a simplified one-step irreversible chemical reaction in which fuel and oxidant react together in stoichiometric proportions giving products with the composition corresponding to a complete combustion. A transport equation is solved for the oxidant and fuel, from which the amount of products and the combustion progress are computed, while the turbulence is modeled with RANS (Reynolds-Average Navier-Stokes). The reaction rate is assumed in the model as proportional to the product of the Flame Surface Density (FSD) by the local laminar flame speed. Aside from the state and composition of the mixture, the local laminar flame speed is affected by the turbulent mixing process. This mixing process is taken into account by means of the classical β -PDF (Probability Density Function), which is a function of the mixture fraction and its variance. A transport equation is solved for both, the mixture fraction and its variance, and the FSD is computed through a transport equation where several models are available for the source terms. The model is implemented in the open-source toolkit OpenFOAM[®]. Computational results are obtained for partially premixed combustions inside constant-volume vessels with several initial configurations, which are compared with numerical results available in the literature.

1 INTRODUCTION

Combustion problems where the reactant species are not homogeneously mixed can be classified in two types, inhomogeneous combustion and partially premixed combustion. Inhomogeneous combustion characterizes by an unburned mixture equivalence ratio, defined as the actual fuel-to-oxidant ratio relative to the stoichiometric fuel-to-oxidant ratio, below one in space and time. On the other hand, in partially premixed combustion the equivalence ratio of the unburned mixture can take values greater than one in space as well as in time. In partially premixed combustion a triple flame can develop in regions where the mixture composition changes from lean to rich, as sketched in Fig. 1. The structure of a triple flame is composed by a lean and a rich premixed flames and a diffusion flame which develops in the zone of the products of the premixed flames. The diffusion flame is formed because of turbulent mixing of relatively hot products, which contain oxidant and fuel from the lean and rich premixed flames, respectively. The flame front propagation is fastest in the region close to the stoichiometric line, thus leading to the nose-shaped structure shown in Fig. 1.

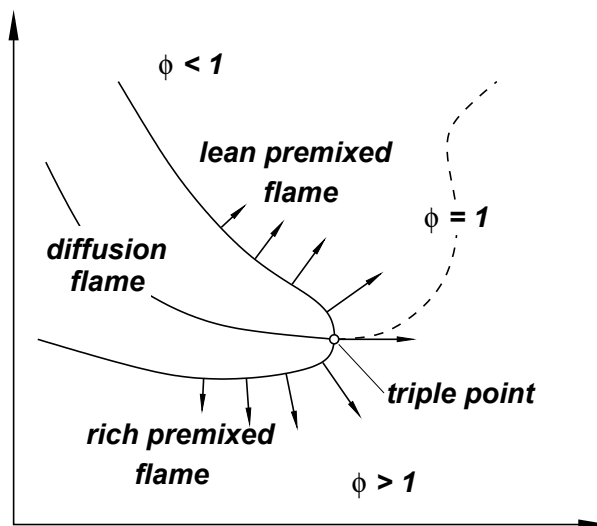

Figure 1: Sketch of the structure of a triple flame in a partially premixed combustion. Adapted from [Kech et al. \(1998\)](#).

Partially premixed combustion can be found in Direct Injection Spark Ignition (DISI) engines operating in the stratified charge mode, because in this case the aim is to generate an inflammable mixture (with composition close to the stoichiometric one) near the spark plug position, while away from this region the mixture is increasingly lean. In DISI engines the combustion process is initiated with a spark which generates an ignition kernel which, once it reaches a critical size, gives place to a self-sustained premixed flame front.

Since partially premixed combustion involves both premixed (typical of spark-ignited engines operating with homogeneous mixture) and diffusion (as in non-premixed diesel combustion) flames, its modelling generally relies on proposals from those types of combustion. [Stiesch and Merker \(2002\)](#) use two separated sub-models, where the premixed flame fronts are modeled using discrete marker particles which track the flame front position, while the secondary diffusion flame is modeled by an eddy-breakup (or characteristic time scale) model. A formulation based on the G -equation model ([Karpov et al., 1996](#)) was proposed by [Kech et al. \(1998\)](#) for modelling combustion in DISI engines. Actually the model by [Kech et al. \(1998\)](#) considers a transport equation for a regress combustion variable with the mean reaction term computed

with a semi-empirical correlation for the turbulent flame speed. Besides, the model includes transport equations for the species mass fractions of fuel, O₂, N₂, CO₂ and H₂O. The model proposed in this work is similar to the one used by Kech et al. (1998), but the turbulent combustion speed is computed with the laminar burning velocity and the Flame Surface Density (FSD) instead of an experimental correlation.

The article is organized as follows. In section §2 the mathematical models are presented, including the transport equations for mass fractions of the considered species and for the FSD. Next section includes a brief description of the numerical implementation. Results for two- and three-dimensional cases are displayed in the following section. Finally, some conclusions are drawn.

2 MATHEMATICAL MODEL

The governing equations of the problem are the Navier-Stokes, continuity and energy equations for compressible flows, where the variables are mass-weighted or Favre averaged. For a variable φ , $\bar{\varphi}$ represents its Reynolds-average while $\tilde{\varphi} = \overline{\rho\varphi}/\bar{\rho}$ stands for the Favre-average, where ρ is the flow density.

The reaction is assumed to take place in a thin sheet and occurs immediately when reactants meet. Then, the concept of Flame Surface Density (FSD) used for premixed combustion is kept in the proposed model for partially premixed combustion. In this work, a one-step irreversible chemical reaction is assumed with the following general form



where F , O and P stand for fuel, oxidizer and products, respectively, and ν_O and ν_P are the stoichiometric coefficients of O and P per unit mol of F , respectively.

Since only three species are considered, two transport equations are to be solved for the mass fraction of two of them. Favre-averaged mass fractions of fuel (\tilde{Y}_F) and oxidizer (\tilde{Y}_O) are transported with the following equations

$$\begin{aligned} \frac{\partial(\bar{\rho}\tilde{Y}_F)}{\partial t} + \frac{\partial(\bar{\rho}\tilde{u}_i\tilde{Y}_F)}{\partial x_i} - \frac{\partial}{\partial x_i} \left(\frac{\bar{\rho}\nu_t}{\sigma_{\tilde{Y}_F}} \frac{\partial\tilde{Y}_F}{\partial x_i} \right) &= -\Omega_F \\ \frac{\partial(\bar{\rho}\tilde{Y}_O)}{\partial t} + \frac{\partial(\bar{\rho}\tilde{u}_i\tilde{Y}_O)}{\partial x_i} - \frac{\partial}{\partial x_i} \left(\frac{\bar{\rho}\nu_t}{\sigma_{\tilde{Y}_O}} \frac{\partial\tilde{Y}_O}{\partial x_i} \right) &= -\Omega_F\lambda_s \end{aligned} \quad (2)$$

where the turbulent transport is modeled with a classical gradient transport assumption. In eq. (2), \tilde{u}_i is the i -th component of the Favre-averaged flow velocity, ν_t is the kinematic turbulent viscosity, $\sigma_{\tilde{Y}_F}$ and $\sigma_{\tilde{Y}_O}$ are the turbulent Schmidt numbers of fuel and oxidizer, respectively, Ω_F is the fuel consumption rate and λ_s is the stoichiometric oxidizer/fuel ratio. Under the hypothesis of reaction confined in very thin sheets, the fuel consumption rate can be computed as

$$\Omega_F = \min \left[\bar{\rho}_u \bar{s}_L \Sigma \tilde{f}_t, \frac{\bar{\rho}}{\Delta t} \min \left(\tilde{Y}_F, \frac{\tilde{Y}_O}{\lambda_s} \right) \right] \quad (3)$$

where $\bar{\rho}_u$ is the density of the unburnt gas, \bar{s}_L is the mean laminar flame velocity (see eq. (7) below), Σ is the FSD, and

$$\tilde{f}_t = \tilde{Y}_F + \frac{1 - \tilde{Y}_F - \tilde{Y}_O}{1 + \lambda_s} \quad (4)$$

The source term Ω_F is defined with a limiter in order to account for the termination of some reactant during the computational time step Δt .

The FSD is computed through a transport equation with the following general form (Choi and Huh, 1998)

$$\frac{\partial \bar{\rho} \Sigma}{\partial t} + \frac{\partial \bar{\rho} \tilde{u}_i \Sigma}{\partial x_i} = \frac{\partial}{\partial x_i} \left(\frac{\bar{\rho} \nu_t}{\sigma_\Sigma} \frac{\partial \Sigma}{\partial x_i} \right) + \bar{\rho} \kappa_m \Sigma + \bar{\rho} \kappa_t \Sigma - \bar{\rho} D - \frac{\partial \tilde{u}_i}{\partial x_i} \bar{\rho} \Sigma \quad (5)$$

where σ_Σ is a turbulent Schmidt number, κ_m and κ_t correspond to the flame surface strain rate induced by the mean flow and the turbulent motions, respectively, and D is a destruction term. Different models for the source terms in eq. (5) were proposed in the literature (Poinsot and Veynante, 2012). Table 1 includes some models which were used to model premixed combustion in closed vessels and in internal combustion engines. The combustion regress needed in the transport equation for the FSD is computed once the mass fractions of fuel and oxidizer are known

$$\tilde{b} = \frac{\min(\tilde{Y}_F, \tilde{Y}_O / \lambda_s)}{\min(\tilde{Y}_F, \tilde{Y}_O / \lambda_s) + (1 - \tilde{Y}_F - \tilde{Y}_O) / (1 + \lambda_s)} \quad (6)$$

The local consumption velocity of reactant species was approximated with the mean laminar burning velocity (see eq. (3)). The laminar burning velocity depends on the type of fuel, oxidizer, the equivalence ratio ϕ or the mixture fraction Z , and the mixture temperature and pressure (Metghalchi and Keck, 1982; Gülder, 1984). Nevertheless, in partially premixed combustion the mixture composition varies in general from point to point. In a turbulent field this lack of homogeneity in the mixture could alter the actual consumption velocity, as pointed out by Kech et al. (1998). Therefore, the mean laminar burning velocity is computed as described in Peters (1997) considering the laminar burning velocity as a stochastic variable depending on the mean mixture fraction \tilde{Z} and the Favre-averaged mixture fraction variance $\widetilde{Z''^2}$, as follows

$$\bar{s}_L(\tilde{Z}) = \int_0^1 s_L(Z) P_Z(\tilde{Z}, \widetilde{Z''^2}) dZ \quad (7)$$

where $P_Z(\tilde{Z}, \widetilde{Z''^2})$ is a Probability Density Function (PDF) and $s_L(Z)$ corresponds to the laminar burning velocity provided by the correlation considered (which is function of the type of fuel, oxidizer, temperature and pressure, besides Z). A classical model for $P_Z(\tilde{Z}, \widetilde{Z''^2})$ is the β -PDF, given by

$$P_Z(\tilde{Z}, \widetilde{Z''^2}) = \frac{Z^{a-1} (1-Z)^{b-1}}{\beta(a, b)} = Z^{a-1} (1-Z)^{b-1} \frac{\Gamma(a+b)}{\Gamma(a)\Gamma(b)} \quad (8)$$

where

$$a = \tilde{Z} \left[\frac{\tilde{Z}(1-\tilde{Z})}{\widetilde{Z''^2}} - 1 \right], \quad b = (1-\tilde{Z}) \left[\frac{\tilde{Z}(1-\tilde{Z})}{\widetilde{Z''^2}} - 1 \right] \quad (9)$$

and $\Gamma(\cdot)$ is the function Gamma defined as

$$\Gamma(\alpha) = \int_0^\infty t^{\alpha-1} e^{-t} dt \quad (10)$$

Equation (7) must be evaluated in each cell for each iteration of the solver at each each time step, thus implying a significant computational cost. Kech et al. (1998) propose to approximate

Model	$\kappa_m \Sigma$	$\kappa_t \Sigma$	D
CPB (Cant et al., 1990)	$A_{ik} \frac{\partial \tilde{u}_k}{\partial x_i} \Sigma$	$\alpha_0 \sqrt{\frac{\tilde{\epsilon}}{\nu}} \Sigma$	$\beta_0 \bar{s}_L \frac{2 + \exp(-aR)}{3\tilde{b}} \Sigma^2$ $R = \frac{\tilde{b}\tilde{\epsilon}}{\Sigma \bar{s}_L \tilde{k}}$
CFM1 (Duclos et al., 1993)	$A_{ik} \frac{\partial \tilde{u}_k}{\partial x_i} \Sigma$	$\alpha_0 \frac{\tilde{\epsilon}}{\tilde{k}} \Sigma$	$\beta_0 \frac{\bar{s}_L + C\sqrt{\tilde{k}}}{\tilde{b}} \Sigma^2$
CFM2a (Duclos et al., 1993)	$A_{ik} \frac{\partial \tilde{u}_k}{\partial x_i} \Sigma$	$\alpha_0 \Gamma_{\tilde{K}} \frac{\tilde{\epsilon}}{\tilde{k}} \Sigma$	$\beta_0 \frac{\bar{s}_L + C\sqrt{\tilde{k}}}{\tilde{b}} \Sigma^2$
CFM2b (Duclos et al., 1993)	$A_{ik} \frac{\partial \tilde{u}_k}{\partial x_i} \Sigma$	$\alpha_0 \Gamma_{\tilde{K}} \frac{\tilde{\epsilon}}{\tilde{k}} \Sigma$	$\beta_0 \frac{\bar{s}_L + C\sqrt{\tilde{k}}}{\tilde{b}(1-\tilde{b})} \Sigma^2$
CFM3 (Veynante et al., 1996)	$A_{ik} \frac{\partial \tilde{u}_k}{\partial x_i} \Sigma$	$\alpha_0 \Gamma_{\tilde{K}} \frac{\tilde{\epsilon}}{\tilde{k}} \Sigma$	$\beta_0 \bar{s}_L \frac{b^* - \tilde{b}}{\tilde{b}(1-\tilde{b})} \Sigma^2 + \bar{s}_L \nabla^2 \tilde{b}$
CD (Cheng and Diringer, 1991)		$\alpha_0 \frac{\tilde{\epsilon}}{\tilde{k}} \Sigma$ if $\kappa_t \leq \alpha_0 K_c \frac{\bar{s}_L}{\delta_L}$	$\beta_0 \frac{\bar{s}_L}{\tilde{b}} \frac{\bar{\rho}_u}{\bar{\rho}} \Sigma^2$
CH1 (Choi and Huh, 1998)		$\alpha_0 \sqrt{\frac{\tilde{\epsilon}}{15\nu}} \Sigma$	$\beta_0 \frac{\bar{s}_L}{\tilde{b}(1-\tilde{b})} \Sigma^2$
CH2 (Choi and Huh, 1998)		$\alpha_0 \frac{u'}{l_{tc}} \Sigma$	$\beta_0 \frac{\bar{s}_L}{\tilde{b}(1-\tilde{b})} \Sigma^2$

Table 1: Different proposed models for the source terms of the transport equation for the FSD. A_{ik} is an orientation factor, \tilde{k} is the turbulent kinetic energy per unit mass, $\tilde{\epsilon}$ is the dissipation of turbulent kinetic energy per unit mass, \tilde{b} is the combustion regress, $\Gamma_{\tilde{K}}$ is the efficiency function in the ITNFS (Intermittent Turbulent Net Flame Stretch) model (Meneveau and Poinso, 1991), K_c is the critical Karlovitz number and δ_L is the laminar flame thickness. In the CH2 model, $u' \approx \sqrt{\tilde{k}}$ and l_{tc} is an arbitrary length scale. α_0, β_0, a, C and b^* ($0 < b^* < 1$) are models parameters.

the computation of the mean laminar burning velocity with the following expression

$$\bar{s}_L(\tilde{Z}) \approx s_{L,Z_{st}} \left[P_{Z_{st}}(\tilde{Z}, \widetilde{Z''^2}) \right]^{2/3} C_{Z_{st}} \tag{11}$$

where $P_{Z_{st}}(\tilde{Z}, \widetilde{Z''^2})$ is the discrete probability to find stoichiometric mixture (represented by Z_{st}), $s_{L,Z_{st}}$ is the laminar burning velocity for stoichiometric mixture, and $C_{Z_{st}} \approx 0.09$.

The mean mixture fraction \tilde{Z} is equal to \tilde{f}_t , defined by eq. (4), and $\widetilde{Z''^2}$ is computed as solution of the following transport equation (Stiesch, 2003)

$$\frac{\partial(\bar{\rho}\widetilde{Z''^2})}{\partial t} + \frac{\partial(\bar{\rho}\tilde{u}_i\widetilde{Z''^2})}{\partial x_i} = \frac{\partial}{\partial x_i} \left(\frac{\bar{\rho}\nu}{Sc_{\widetilde{Z''^2}}} \frac{\partial \widetilde{Z''^2}}{\partial x_i} \right) + \frac{2\bar{\rho}\nu}{Sc_{\widetilde{Z''^2}}} \left(\frac{\partial \tilde{Z}}{\partial x_i} \right)^2 - \bar{\rho}\tilde{\chi} \tag{12}$$

where $Sc_{\widetilde{Z''^2}}$ is a turbulent Schmidt number for $\widetilde{Z''^2}$ and $\tilde{\chi}$ is the mean scalar dissipation rate, which can be modeled as (Jones and Whitelaw, 1982)

$$\tilde{\chi} = C_\chi \frac{\tilde{\epsilon}}{\tilde{k}} \widetilde{Z''^2} \tag{13}$$

with $C_\chi = 2.0$.

2.1 Ignition

The ignition is represented with a very simple model expressed as

$$(\bar{\rho}\Sigma)_c = \bar{\rho}_u \frac{4\pi r_0^2}{V_c} \quad (14)$$

where r_0 is the initial kernel radius and V_c is the cell volume where the ignition takes place. This equation is applied in order to give an initial value for Σ , which is later transported using eq. (5).

3 IMPLEMENTATION

The model was implemented in the Finite Volume program OpenFOAM[®]. The pressure/velocity coupling is solved by means of the combination of the PISO (Pressure-Implicit with Splitting Operators, Versteeg and Malalasekera (2007)) and the SIMPLE (Semi-Implicit Method for Pressure-Linked Equations, Patankar (1980)) algorithms. This combination is termed PIMPLE in OpenFOAM[®]. The PISO algorithm is a predictor-corrector method that iterates, at each time step, a fixed amount of times through the equations by performing an external iteration (momentum predictor) and two or more internal iterations for the pressure/velocity corrector. Both the momentum predictor and the pressure corrector step give rise to a system of linear equations resulting from the discretization of the corresponding differential equations, while the correcting step for velocity is explicit. The PIMPLE strategy, in comparison to the PISO algorithm, allows to use a greater number of external iterations with sub-relaxation factors for each time step, render it similar to the SIMPLE scheme.

The equations added to the compressible solver are those corresponding to the fuel and oxidant mass fractions, the FSD, and the mixture fraction variance. These equations are solved in a decoupled fashion between the momentum predictor step and the corrector step. The discretization of these equations give rise to systems of linear equations with sparse matrices, which are solved for each time step as many times as the number of external iterations specified by the user.

4 RESULTS

The model described in section §2 is applied to solve partially premixed combustion in constant-volume vessels in both two- and three-dimensions. Two-dimensional cases were taken from the literature but due to the lack of detailed results, comparison is performed qualitatively only.

For the whole set of cases, the temporal derivatives were discretized using the Crank-Nicolson scheme and gradients were discretized by means of central differences. Regarding divergence operators, for velocity a second order upwind-biased was applied (`Gauss linearUpwindV grad(U)` option in OpenFOAM[®]), while for the remaining fields central differences with Sweby (1984) limiter was employed (`Gauss limitedLinear 1` option in OpenFOAM[®]).

The initial flame radius in eq. (14) was $r_0 = 0.5$ mm in all tests. In addition, the laminar burning velocity is computed with the correlation proposed by Gülder (1984), while the Sutherland law is used to correct the dynamic viscosity with temperature. Turbulence is modeled with the standard $k - \epsilon$ model and the CFM2a model (see Table 1) is used for the FSD equation with $\alpha_0 = 6.2$, $\beta_0 = 0.25$ and $C = 0.5$.

4.1 Two-dimensional combustion bomb with linear distribution of the equivalence ratio

This test consist in a partially premixed combustion inside a two-dimensional (2D) closed vessel with rectangular shape. The initial distribution of mixture is such that the equivalence ratio varies linearly with the vessel height. Two versions of the test were found in the literature, both of which are presented in the following sections.

4.1.1 Case 1

This first case was proposed by [Stiesch and Merker \(2002\)](#) and is sketched in Fig. 2. Because the dimensions of the vessel are missed in the original work, the following values are adopted here: $h = 100$ mm and $L = 200$ mm. The position of the ignition is estimated as shown in Fig. 2. The fuel is iso-octane and the oxidizer is air, which are initially mixed as indicated by the equivalence ratio profile shown in Fig. 2. The initial distribution of equivalence ratio depends on the vessel height only. Initially, the fluid is at rest. In addition, the initial pressure is $p_0 = 101$ kPa, the initial mixture temperature is $\tilde{T}_0 = 700$ K, the initial turbulent kinetic energy is $\tilde{k}_0 = 9$ m²/s², and its initial dissipation rate is $\tilde{\epsilon}_0 = 1627.5$ m²/s³.

Regarding the boundary conditions, the no-slip condition over the bomb wall is imposed for velocity and zero normal gradient for the remaining variables. The problem domain is discretized with a homogeneous mesh with 81×41 cells. The time step is computed based on the maximum CFL (Courant-Friedrichs-Levy) number, limited to 0.5.

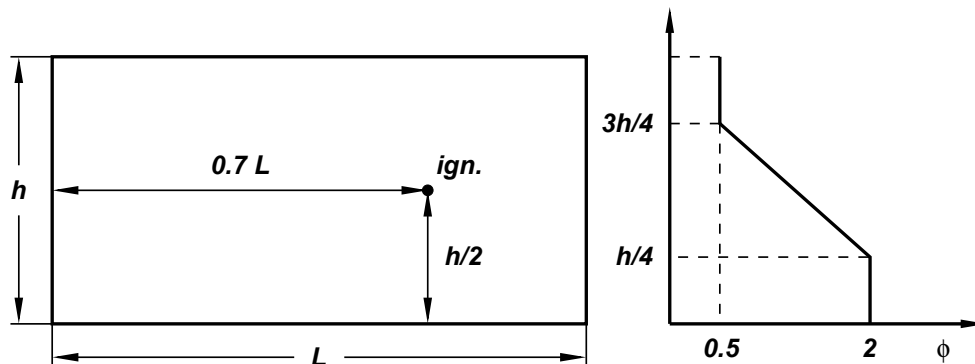

Figure 2: Sketch of the geometry and the initial equivalence ratio distribution in the case 1 of the two-dimensional combustion bomb test.

Figures 3 and 4 show the mass fraction distribution of fuel and oxidant for several simulation times. For the same time instants, figures 5 and 6 present the FSD and temperature fields. A premixed flame is initially observed, where the upper part is a lean premixed flame and the bottom part is a rich one. In the region occupied by the combustion products a diffusive flame develops, which is clearly visible from $t = 4$ ms. Since the laminar burning velocity is higher for mixtures close to the stoichiometric compositions and decreases as the mixture becomes lean or rich, the premixed flame front exhibits an oval-shape until its interaction with the wall.

At $t \approx 4$ ms a similar flame configuration to the one presented in [Stiesch and Merker \(2002\)](#) is observed, but they reach the result for $t = 1$ ms. This difference could be due to the turbulence levels considered in this work, since [Stiesch and Merker \(2002\)](#) do not explicitly state them.

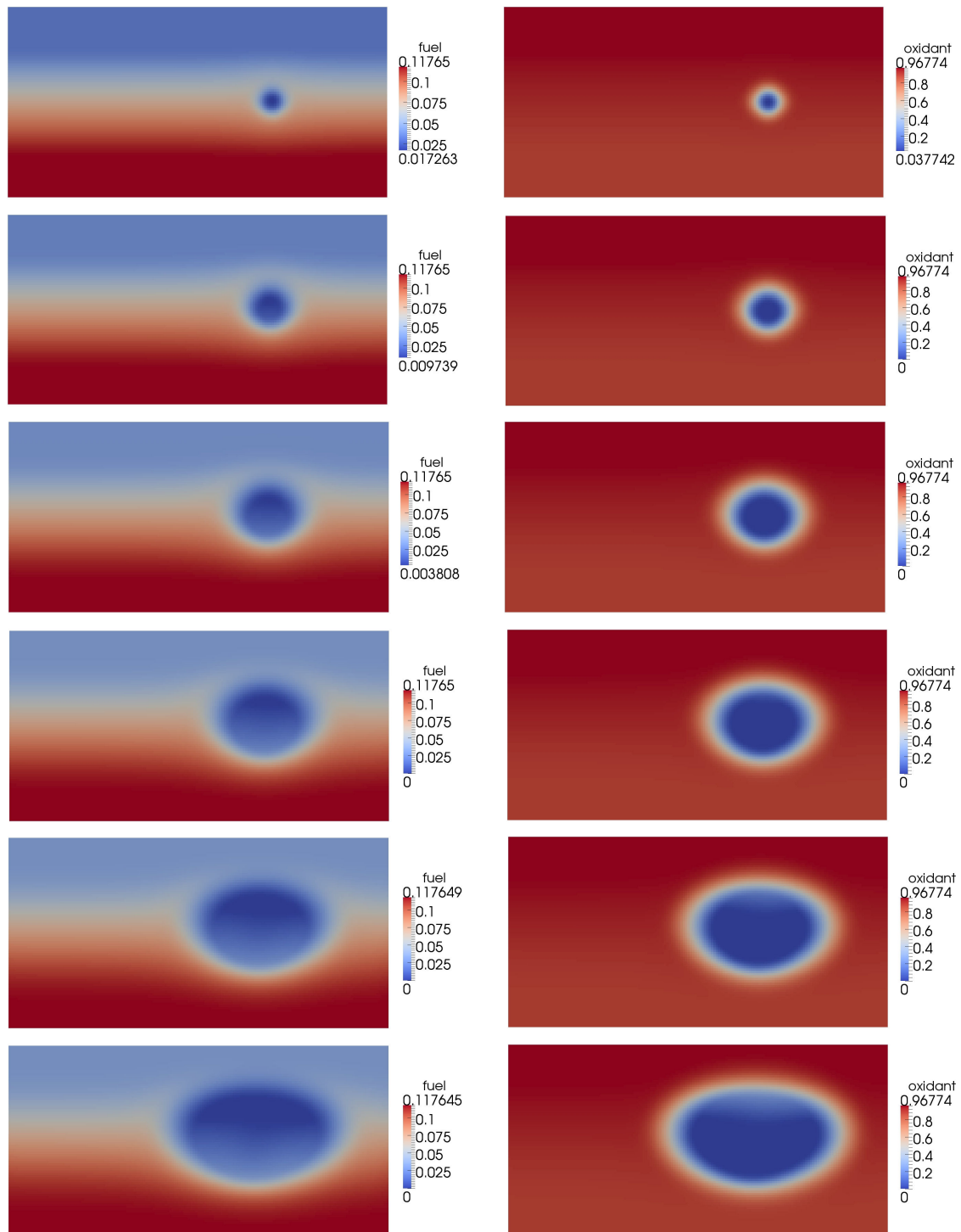

Figure 3: Partially premixed combustion in a two-dimensional closed vessel with an initial equivalence ratio distribution which varies linearly with the vessel height, case 1. Left: field \tilde{Y}_F . Right: field \tilde{Y}_O . From top to bottom, $t = 1, 2, 3, 4, 5, 6$ ms.

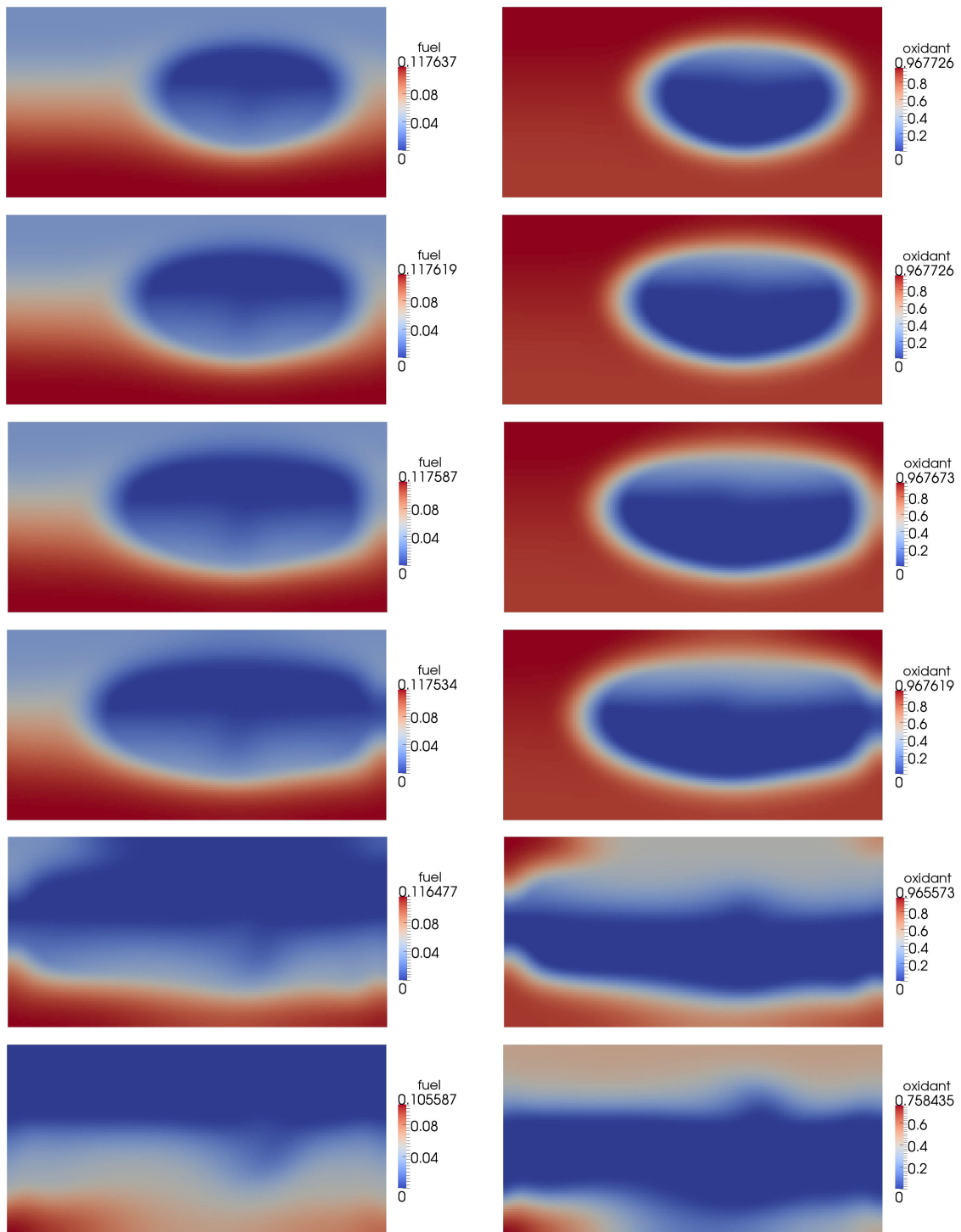

Figure 4: Partially premixed combustion in a two-dimensional closed vessel with an initial equivalence ratio distribution which varies linearly with the vessel height, case 1. Left: field \tilde{Y}_F . Right: field \tilde{Y}_O . From top to bottom, $t = 7, 8, 9, 10, 15, 20$ ms.

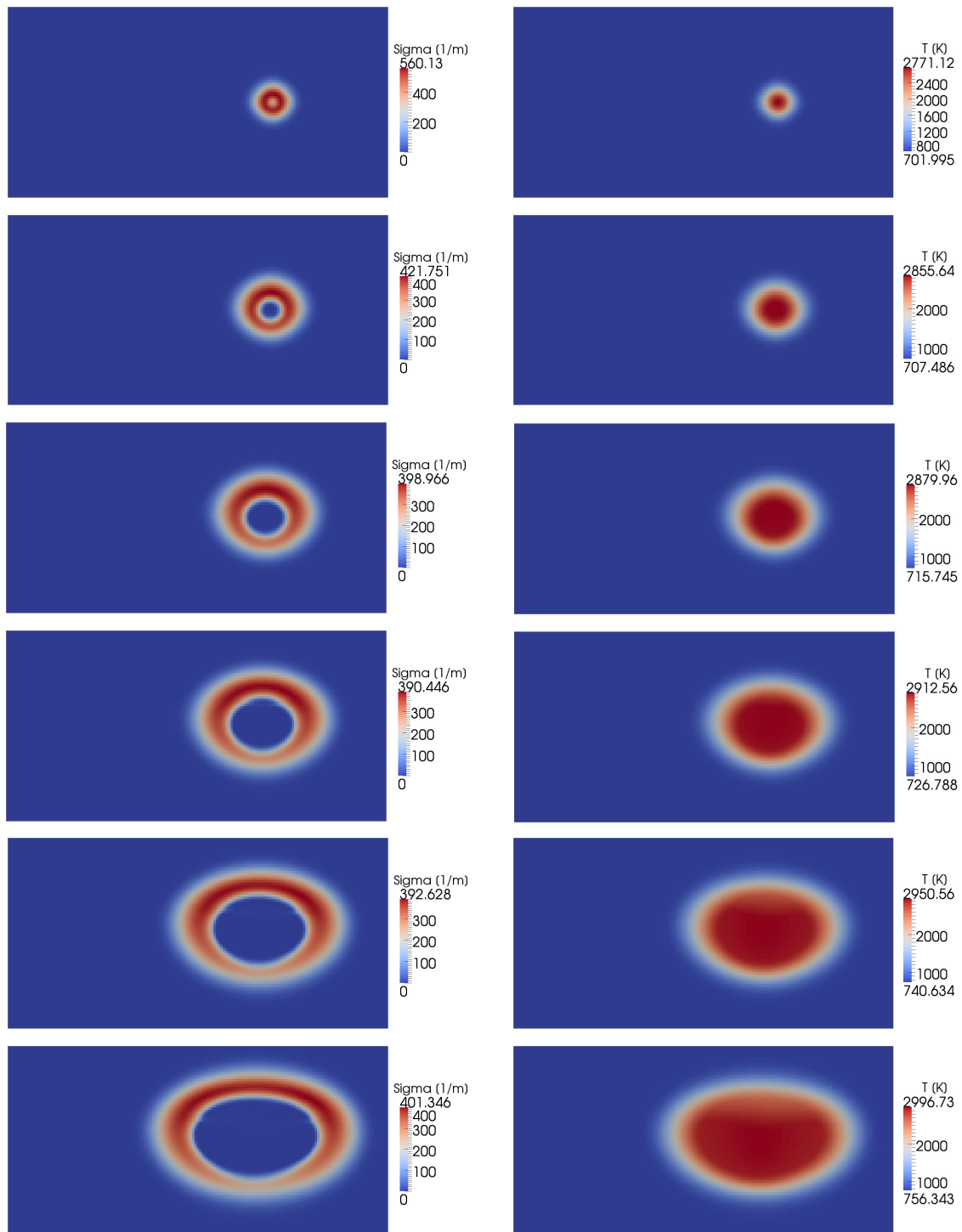

Figure 5: Partially premixed combustion in a two-dimensional closed vessel with an initial equivalence ratio distribution which varies linearly with the vessel height, case 1. Left: field Σ . Right: temperature. From top to bottom, $t = 1, 2, 3, 4, 5, 6$ ms.

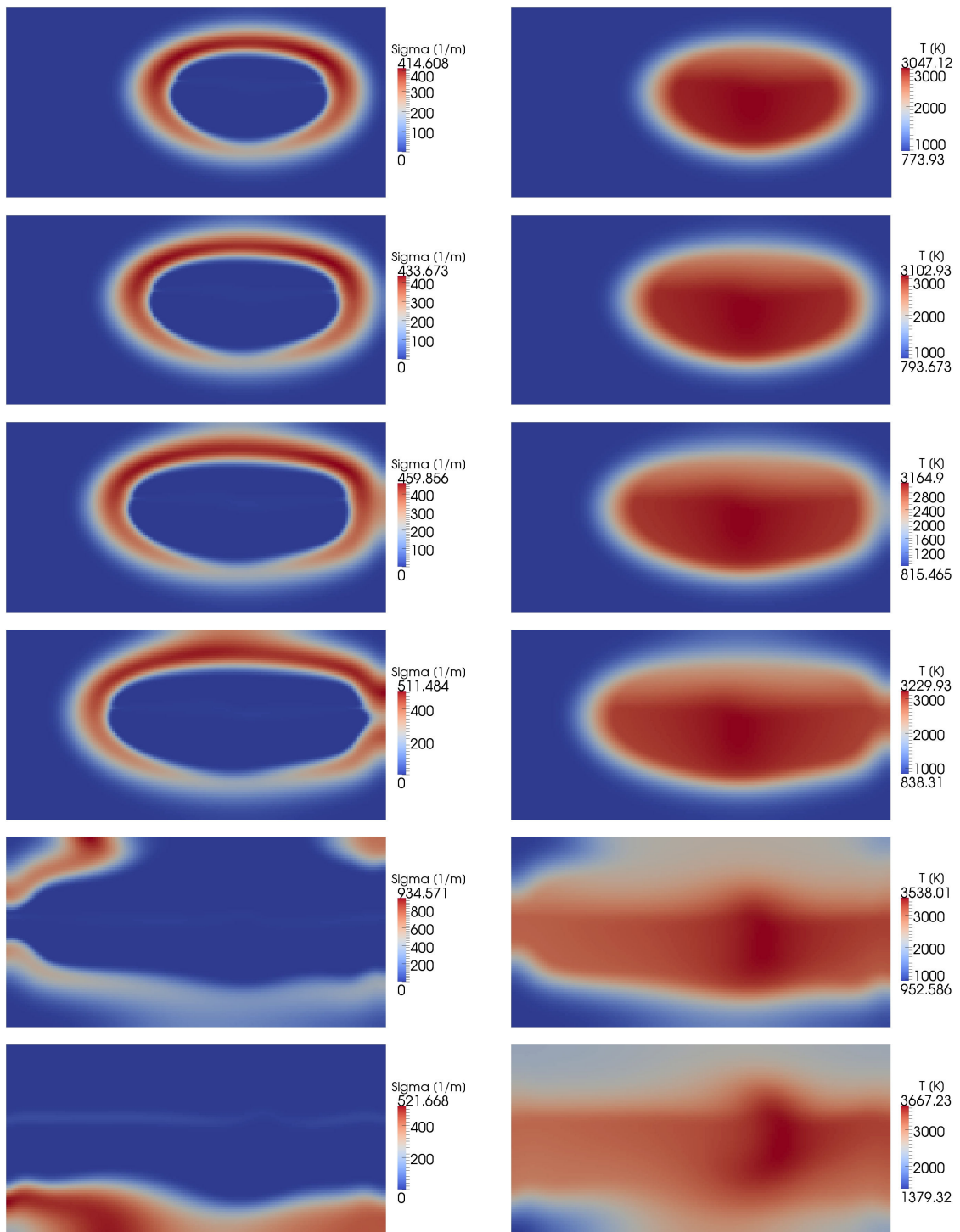

Figure 6: Partially premixed combustion in a two-dimensional closed vessel with an initial equivalence ratio distribution which varies linearly with the vessel height, case 1. Left: field Σ . Right: temperature. From top to bottom, $t = 7, 8, 9, 10, 15, 20$ ms.

4.1.2 Case 2

Figure 7 shows an outline of this version of the test, which was proposed by Kech et al. (1998). The ignition takes place at a position where the mixture has stoichiometric composition. Again, the fuel is iso-octane, the oxidizer is air, and the initial mixture composition is indicated in Fig. 7. Others variables have the same initial values as in case 1.

The mesh has 161 cells in the horizontal direction and 121 cells in the vertical one, with a homogeneous distribution. The remaining configuration of the case is the same as in case 1.

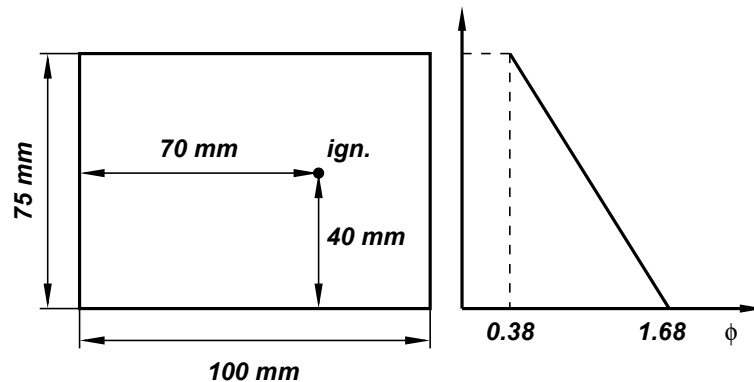

Figure 7: Sketch of the geometry and the initial equivalence ratio distribution in the case 2 of the two-dimensional combustion bomb test.

Fields of FSD, fuel and oxidant for some time instants during the simulation are shown in Fig 8. Figure 9 presents the temperature distribution at these time instants. These results are qualitatively similar to the ones obtained in the case 1, with lean and rich premixed flames and a diffusion flame developed on the products side.

In this case, the shape of the flame is different from the result presented by Kech et al. (1998), even when both models are very similar. The main difference between the model proposed by Kech et al. (1998) and the one presented in this work is the computation of the fuel consumption rate, where in the former it is assumed as

$$\Omega_F = \bar{\rho}_u s_T \|\nabla \tilde{b}\| \tilde{f}_t \quad (15)$$

with s_T a turbulent velocity taken from the correlation given by Maly and Herweg (1992).

4.2 Three-dimensional combustion bomb

This three-dimensional test was proposed as a modification of the cubic combustion bomb case solved by Choi and Huh (1998), who used the test as validation of premixed combustion models. The problem domain has 12 cm in side and the ignition is at the center of the cube. Initially the fluid is at rest, the pressure is $p_0 = 1$ atm, the temperature is $\tilde{T}_0 = 355.77$ K, the turbulent kinetic energy is $9 \text{ m}^2/\text{s}^2$ and its dissipation rate is $1627.5 \text{ m}^2/\text{s}^3$. Following the setting of the original case, the turbulence is assumed frozen. The fuel is iso-octane and the oxidant is air, where half of the cube has a lean mixture and the other half a rich mixture, as shown in Fig. 10.

The bomb is discretized with a homogeneous mesh with 41 cells per side. On the walls of the bomb the no-slip condition is imposed for the fluid velocity while a zero gradient condition is imposed for the remaining variables.

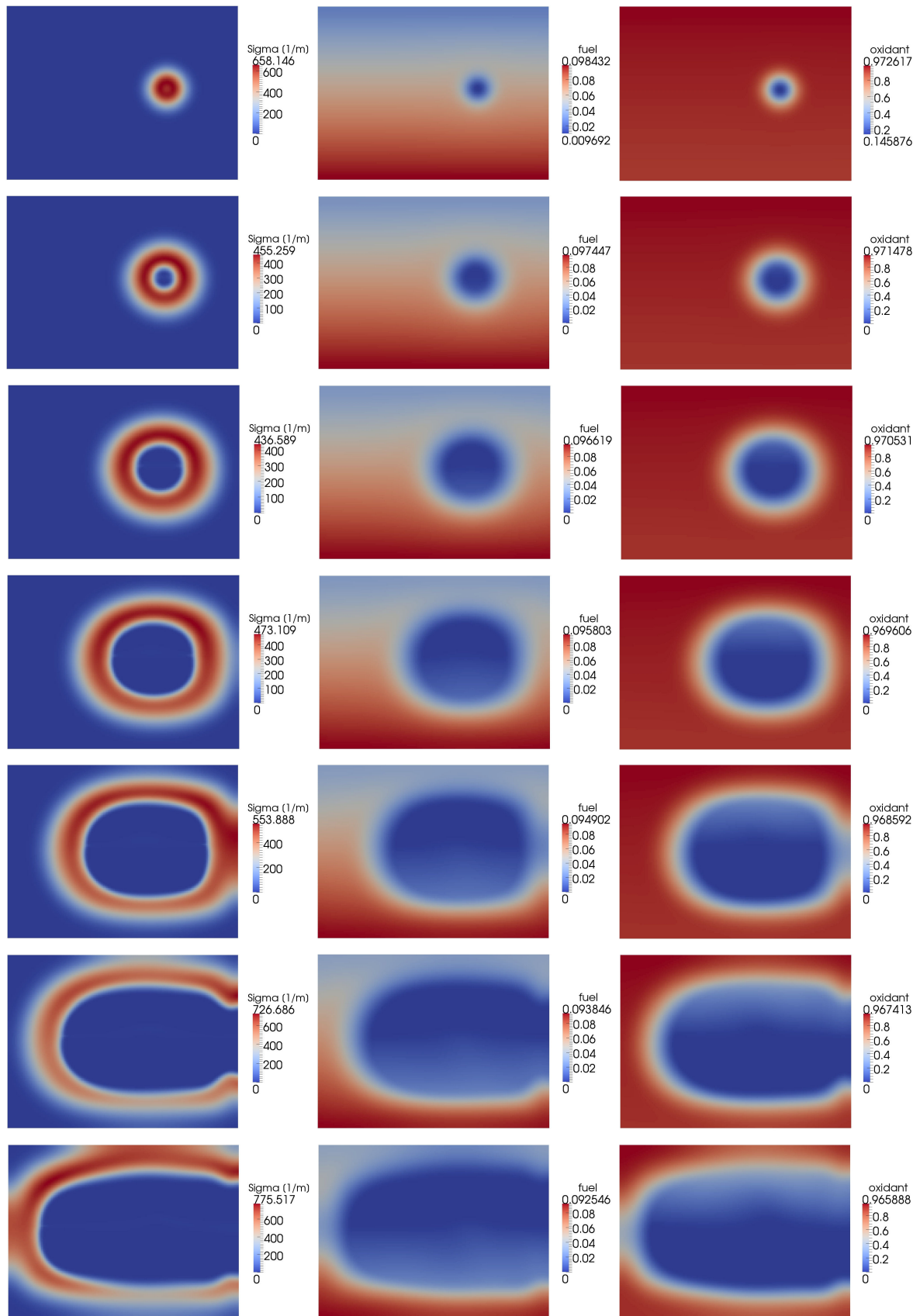

Figure 8: Partially premixed combustion in a two-dimensional closed vessel with an initial equivalence ratio distribution which varies linearly with the vessel height, case 2. Left: field Σ . Center: field \tilde{Y}_F . Right: field \tilde{Y}_O . From top to bottom, $t = 1, 2, 3, 4, 5, 6, 7$ ms.

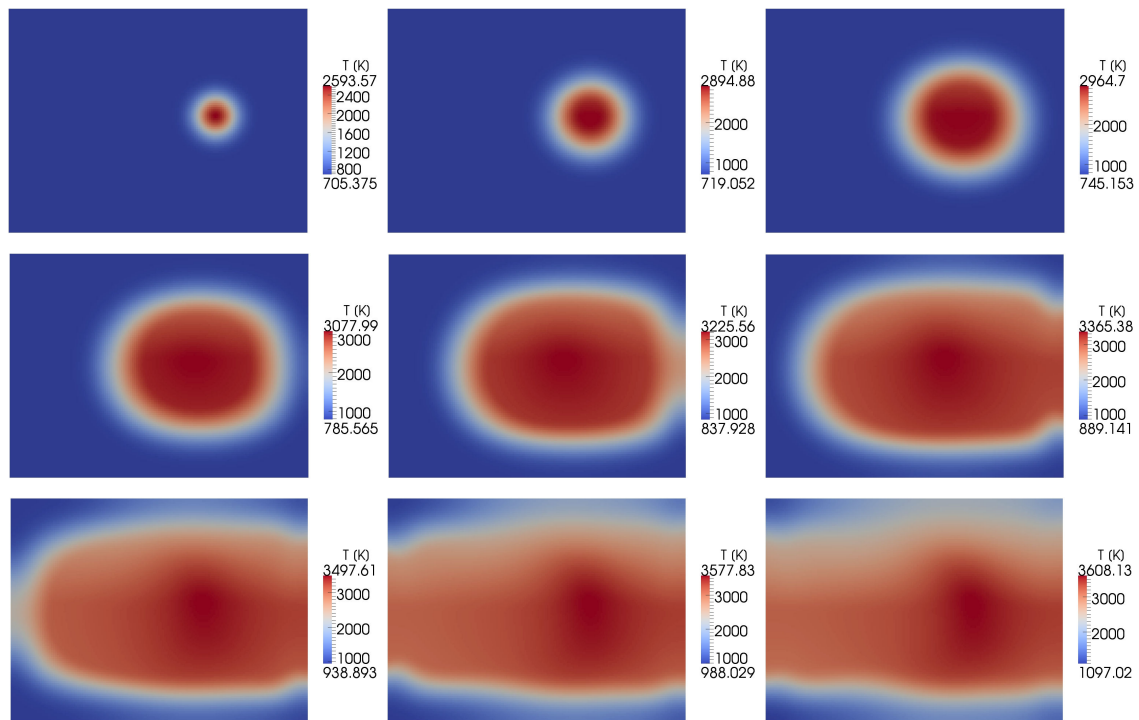

Figure 9: Partially premixed combustion in a two-dimensional closed vessel with an initial equivalence ratio distribution which varies linearly with the vessel height, case 2. Temperature field. From left to right and from top to bottom, $t = 1, 2, 3, 4, 5, 6, 7, 8, 9$ ms.

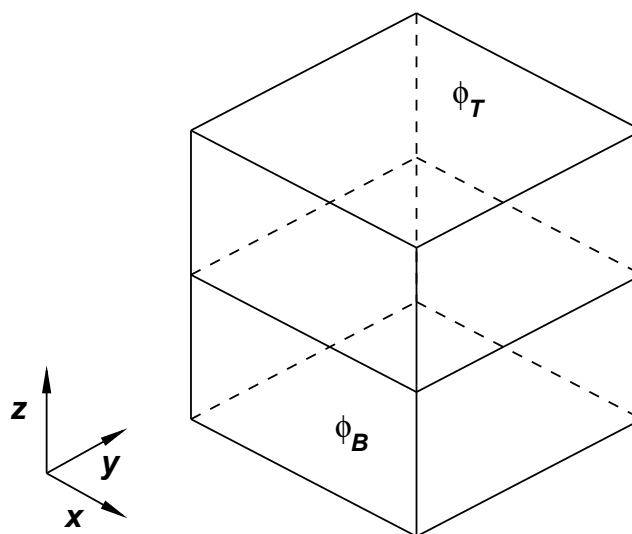

Figure 10: Partially premixed combustion inside a cubic closed vessel. Scheme of the domain geometry. Top half: rich mixture ($\phi_T = 1.216$), bottom half: lean mixture ($\phi_B = 0.789$).

Figures 11 to 13 show the distribution of fuel, oxidant and FSD on a plane crossing the center of the vessel for several time instants during the simulation. As observed, two premixed flames develop in the top and bottom halves of the cube. These flames have an approximate hemispherical shape while they do not reach the walls. A diffusion flame develops in the products side and is perfectly visible from $t = 5$ ms onwards. At $t = 9$ ms, approximately, the premixed flames are extinguished and the reaction continues thanks to the diffusion flame.

Figure 14 presents the temperature distribution on the same middle plane as previous figures. Until $t = 6$ ms the highest temperatures are reached in the ignition zone. Later, due to the fluid movement, this region displaces to the bottom of the bomb.

5 CONCLUSIONS

A model able to solve partially premixed combustion was presented for turbulence represented with RANS models. The Favre-averaged reaction rate was assumed proportional to the mean laminar burning velocity and the Flame Surface Density (FSD). The FSD is transported by an equation whose source terms are modeled using proposals from the premixed combustion case. Since the laminar burning velocity is assumed a stochastic variable, the mean laminar burning velocity is computed using a probability density function, in particular the β -PDF, depending on the mean mixture fraction and its mean variance. A simplified chemical reaction between two reactants, fuel and oxidant, to give combustion products was adopted. The model was applied to combustion cases in closed vessels, being able to capture the triple flame structure. Validation of the model remains incomplete, since comparison with numerical solutions from the literature was qualitative and in one case the results obtained did not match the presented by the authors of that test. As future work a comprehensive validation of the model is proposed, as well as the inclusion of more precise models for the chemical scheme, the ignition process and the quenching of the flame at solid walls.

ACKNOWLEDGMENTS

This work has received financial support from Consejo Nacional de Investigaciones Científicas y Técnicas (CONICET, Argentina), Universidad Nacional del Comahue (UNCo, Argentina, grant PI 04/I215), and Agencia Nacional de Promoción Científica y Tecnológica (ANPCyT, Argentina, grants PICT 2014-2460, PICT 2015-2904), and was partially performed with the Free Software Foundation GNU-Project resources as GNU/Linux OS, GCC compilers, GNU/Octave, and GNU/GIMP, as well as other Open Source resources as OpenFOAM[®], ParaView, Xfig, and L^AT_EX, among many others.

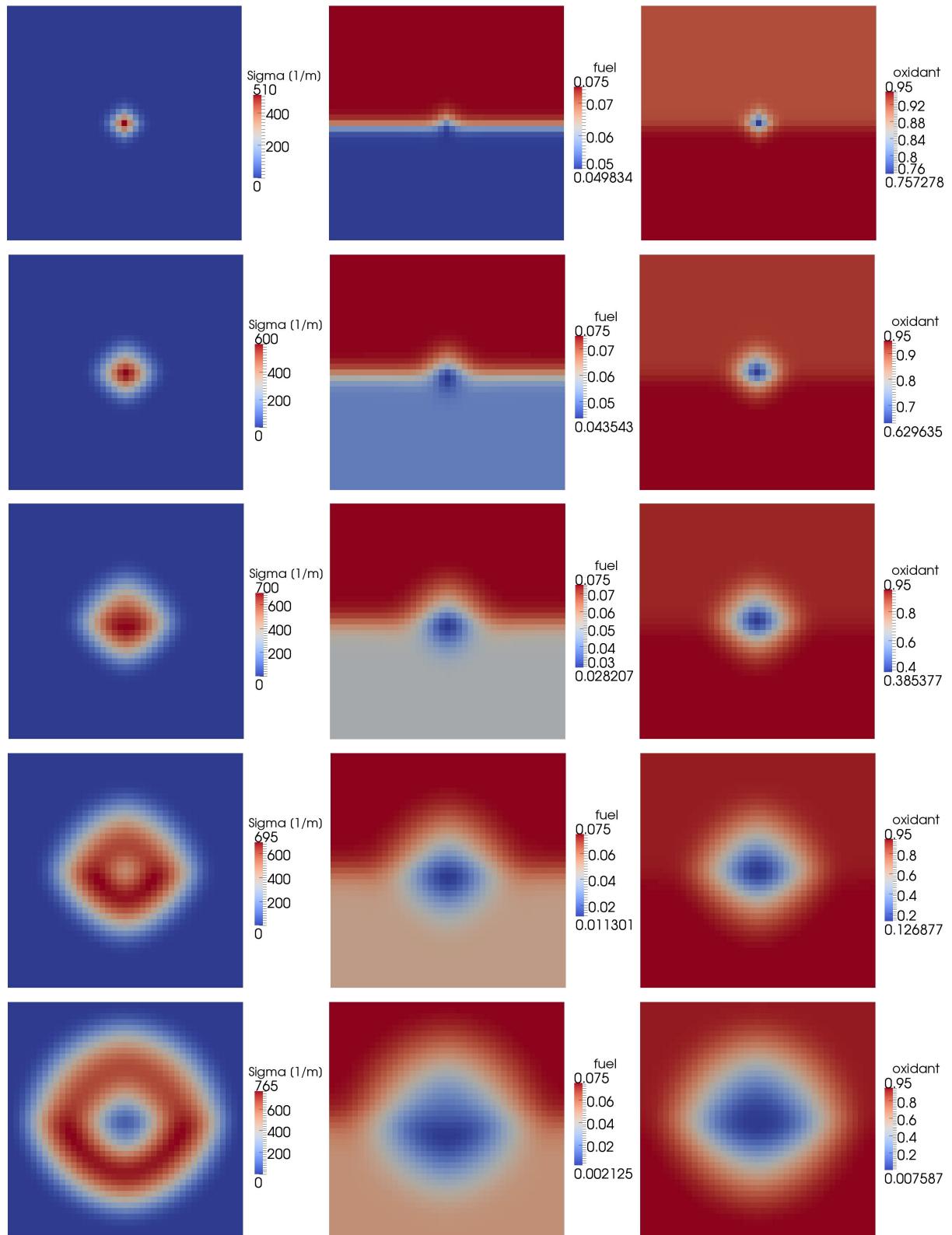

Figure 11: Partially premixed combustion inside a cubic closed vessel. Top half: rich mixture ($\phi_T = 1.216$), bottom half: lean mixture ($\phi_B = 0.789$). Fields on a plane crossing the center of the combustion bomb. Left: field Σ . Center: field \tilde{Y}_F . Right: field \tilde{Y}_O . From top to bottom, $t = 1, 2, 3, 4, 5$ ms.

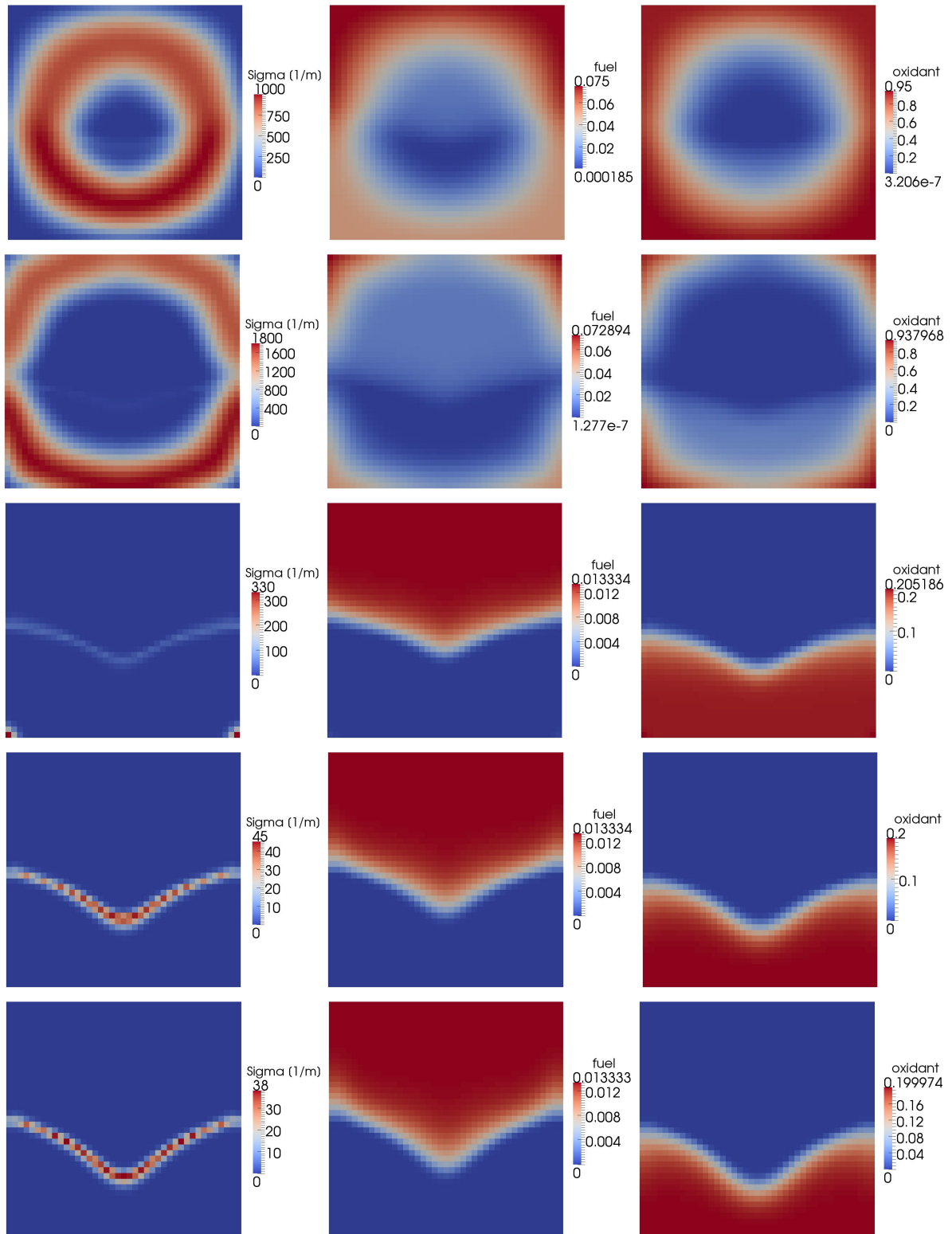

Figure 12: Partially premixed combustion inside a cubic closed vessel. Top half: rich mixture ($\phi_T = 1.216$), bottom half: lean mixture ($\phi_B = 0.789$). Fields on a plane crossing the center of the combustion bomb. Left: field Σ . Center: field \tilde{Y}_F . Right: field \tilde{Y}_O . From top to bottom, $t = 6, 7, 8, 9, 10$ ms.

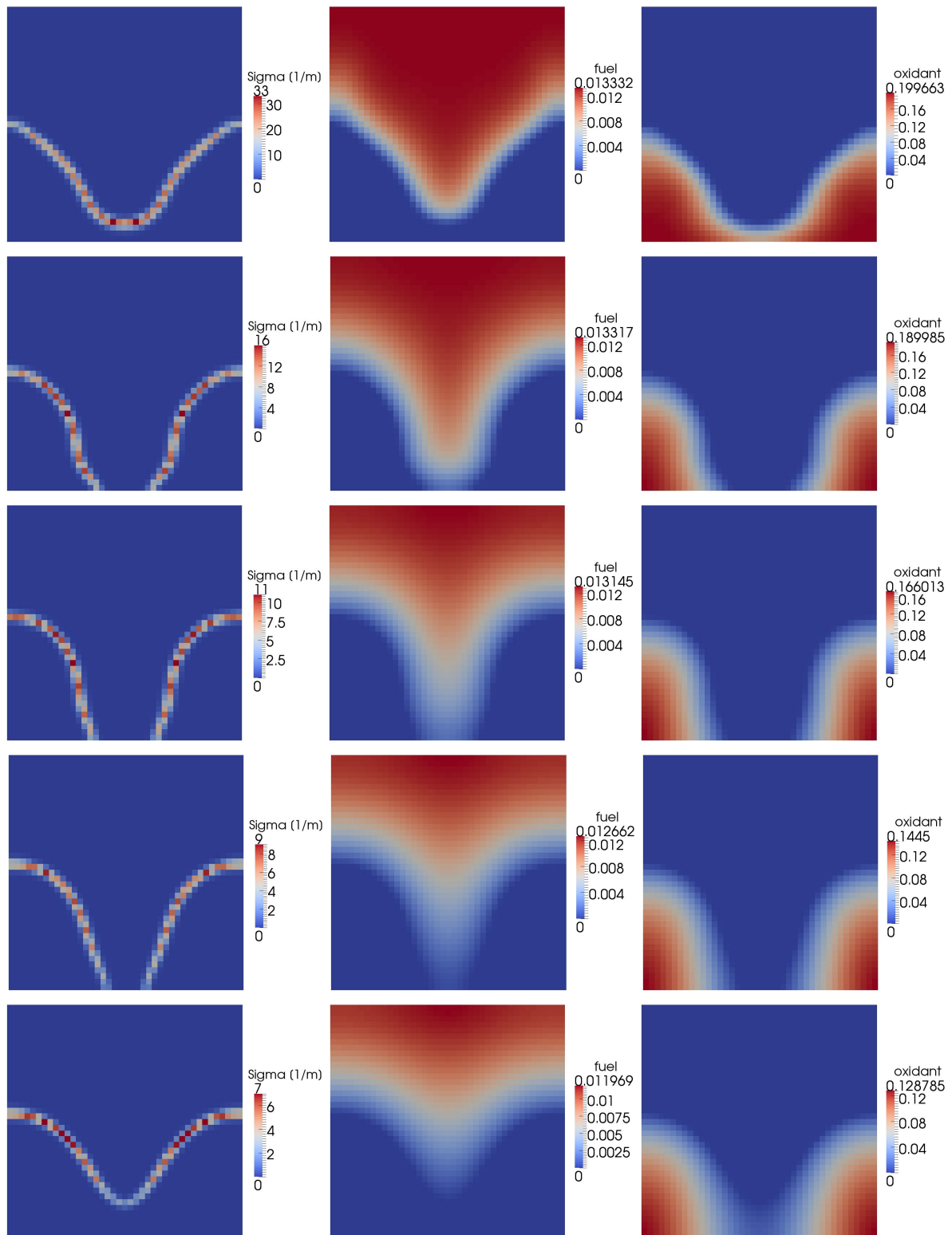

Figure 13: Partially premixed combustion inside a cubic closed vessel. Top half: rich mixture ($\phi_T = 1.216$), bottom half: lean mixture ($\phi_B = 0.789$). Fields on a plane crossing the center of the combustion bomb. Left: field Σ . Center: field \tilde{Y}_F . Right: field \tilde{Y}_O . From top to bottom, $t = 20, 40, 60, 80, 100$ ms.

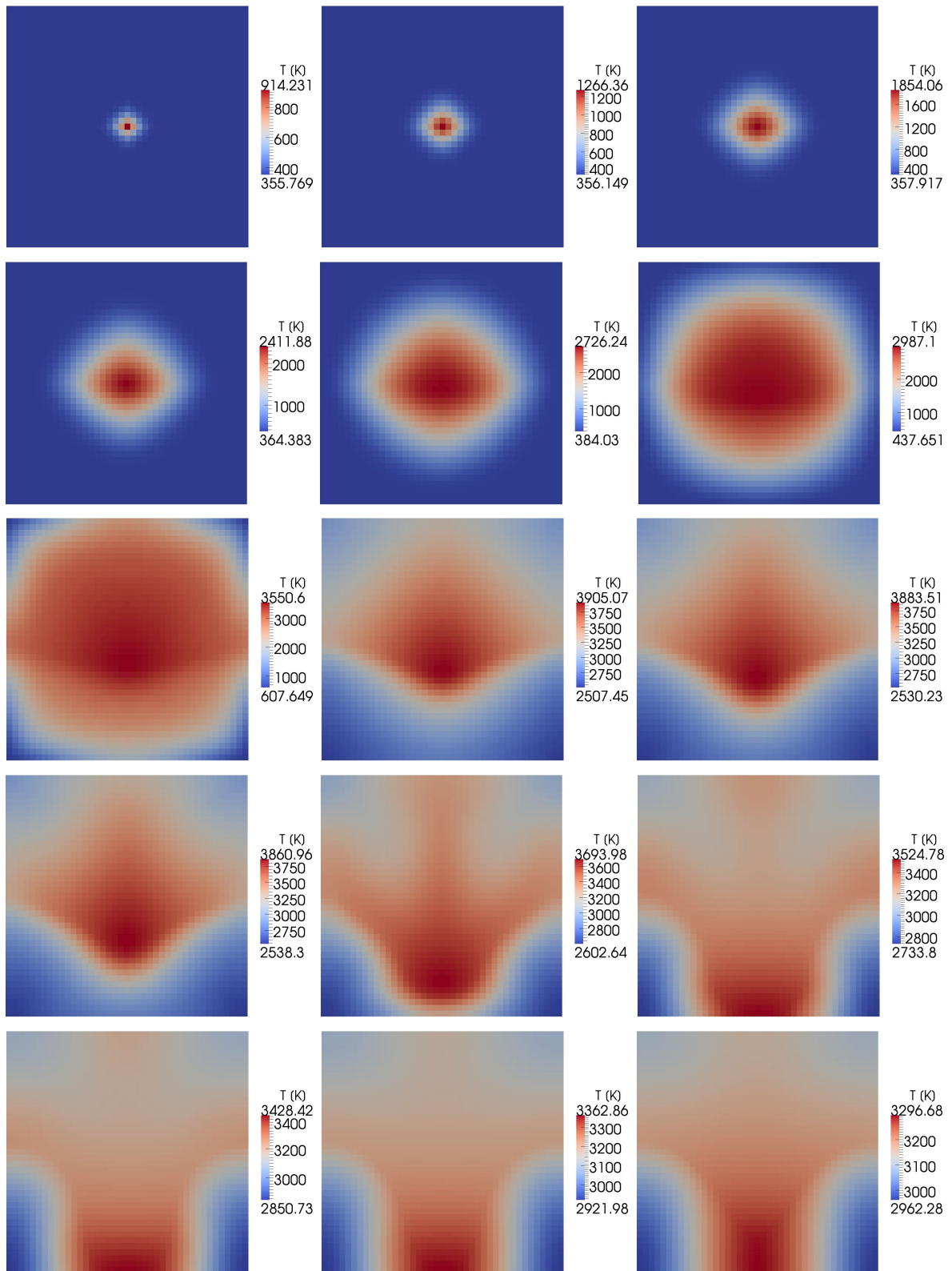

Figure 14: Partially premixed combustion inside a cubic closed vessel. Top half: rich mixture ($\phi_T = 1.216$), bottom half: lean mixture ($\phi_B = 0.789$). Distribution of temperature on a middle plane. From left to right and from top to bottom, $t = 1, 2, 3, 4, 5, 6, 7, 8, 9, 10, 20, 40, 60, 80, 100$ ms.

REFERENCES

- Cant R., Pope B., and Bray K. Modelling of flamelet surface-to-volume ratio in turbulent premixed combustion. In *Twenty-Third Symposium (International) on Combustion/The Combustion Institute*, pages 809–815. 1990.
- Cheng W. and Diringer J. Numerical modelling of SI engine combustion with a flame sheet model. *SAE Technical Paper*, 910268, 1991.
- Choi C. and Huh K. Development of a coherent flamelet model for a spark-ignited turbulent premixed flame in a closed vessel. *Combustion and Flame*, 114:336–348, 1998.
- Duclos J., Veynante D., and Poinso T. A comparison of flamelet models for premixed turbulent combustion. *Combustion and Flame*, 95:101–117, 1993.
- Gülder O. Correlations of laminar combustion data for alternative SI engine fuels. *SAE Technical Paper*, 841000, 1984.
- Jones W. and Whitelaw J. Calculation methods for reacting turbulent flows: a review. *Combustion and Flame*, 48:1–26, 1982.
- Karpov V., Lipatnikov A., and Zimont V. A test of an engineering model of premixed turbulent combustion. In *26th Symposium (International) on Combustion*, pages 249–257. The Combustion Institute, Pittsburg, 1996.
- Kech J., Reissing J., J. G., and Spicher U. Analyses of the combustion process in a direct injection gasoline engine. In *The Fourth International Symposium COMODIA*, pages 287–292. 1998.
- Maly R. and Herweg R. A fundamental model for flame kernel formation in SI engines. *SAE Technical Paper*, 922243, 1992.
- Meneveau C. and Poinso T. Stretching and quenching of flamelets in premixed turbulent combustion. *Combustion and Flame*, 86:311–332, 1991.
- Metghalchi M. and Keck J. Burning velocities of mixtures of air with methanol, isooctane, and indolene at high pressure and temperature. *Combustion and Flame*, 48:191–210, 1982.
- Patankar S. *Numerical Heat Transfer and Fluid Flow*. Taylor & Francis, 1980.
- Peters N. Four lectures on turbulent combustion. ERCOFTAC Summer School, Aachen, 1997.
- Poinso T. and Veynante D. *Theoretical and Numerical Combustion*. Poinso T. and Veynante D., 3 edition, 2012.
- Stiesch G. *Modeling Engine Spray and Combustion Processes*. Springer-Verlag, Berlin, 2003.
- Stiesch G. and Merker G. A simplified model for description of triple flames in stratified charge gasoline engines. In *12th Int. Multidim. Engine Modeling Users Group*. Detroit, MI, 2002.
- Sweby P. High resolution schemes using flux limiters for hyperbolic conservation laws. *SIAM Journal on Numerical Analysis*, 21:995–1011, 1984.
- Versteeg H. and Malalasekera W. *An Introduction to Computational Fluid Dynamics: The Finite Volume Method*. Pearson, 2 edition, 2007.
- Veynante D., Piana J., Duclos J., and Martel C. Experimental analysis of flame surface density models for premixed turbulent combustion. In *Twenty-Sixth Symposium (International) on Combustion/The Combustion Institute*, pages 413–420. 1996.