

A research agenda for life cycle assessment of electromobility

Final report for *Pre-study regarding a nexus for life cycle assessment of electromobility*

A project associated with the *Electromobility in Society* theme of the Swedish Electromobility Centre
Funded by the Swedish Energy Agency (Project no. 47915-1)

Anders Nordelöf & Rickard Arvidsson
Chalmers University of Technology

English project title: Pre-study regarding a nexus for life cycle assessment of electromobility

Swedish project title: Förstudie avseende ett nexus för livscykelanalys av elektromobilitet

Project manager: Anders Nordelöf

Researchers:

Anders Nordelöf, Chalmers University of Technology, principal investigator

Rickard Arvidsson, Chalmers University of Technology, principal investigator

Collaborating industry:

PowerCell Sweden AB

Vattenfall AB

Volvo Car Corporation

Scania CV AB

Stena Bulk AB

Year: 2019

Keywords: Life cycle assessment; electromobility; electric vehicle; battery; literature review; nexus

Contents

Sammanfattning 3
Summary 3
Background 4
General project description 8
Method 9
Results 13
Discussion 18
Research agenda for LCA of electromobility..... 21
Utilization of results 21
SEC targets and research program relevance 22
References 23

Sammanfattning

Detta är en förstudie, finansierad av Energimyndigheten, med syfte att presentera en forskningsagenda för livscykelanalys (LCA) av elektromobilitet. Elfordon målas ofta upp som en möjlig lösning på olika miljöproblem, framför allt global uppvärmning. Samtidigt visar utförda LCA-studier att elfordon även kan försämra vissa miljöproblem genom ökad abiotisk resursanvändning och emissioner av toxiska ämnen. Huruvida elfordon verkligen minskar påverkan på global uppvärmning beror dessutom på hur produktionen av el går till. Denna typ av tvetydiga resultat pekar på vikten av systematisk utvärdering av miljö- och resursprestandan hos elektromobilitet, till exempel med hjälp av LCA. Med tanke på de många överlapp som finns mellan LCA och elektromobilitet kan det betraktas som ett *nexus* innehållande dels olika teknologier (batterier, bränsleceller, elektronik, elmotorer, med mera) och dels olika miljöaspekter (resursanvändning, deras kritikalitet, energirelaterade emissioner, med mera). För att avgöra vilka delar av detta *nexus* som är intressantast att studera ytterligare samlades information från följande tre källor in: (1) möten med relevanta industriintressenter, (2) intervjuer med forskare inom fältet och (3) en litteraturstudie av nyckeldokument inom LCA av elektromobilitet. Resultatet presenteras i form av en forskningsagenda för LCA av elektromobilitet som består av tio forskningsfrågor. Sju av dessa handlar om olika teknologier inom elektromobilitet som är viktiga att studera (till exempel nya batterikemier och elflyg) och tre handlar om metodfrågor (till exempel bedömning av abiotiska resurser). Två forskningsprojekt har formulerats där avsikten att redan under 2019 ansöka om finansiering, och dessa täcker tillsammans en majoritet av forskningsfrågorna.

Summary

This is a pre-study, financed by the Swedish Energy Agency, with the aim of presenting a research agenda for life cycle assessment (LCA) of electromobility. Electric vehicles are often portrayed as potential remedies for numerous environmental problems, most notably global warming. At the same time, LCA studies already conducted have shown that electric vehicles can also worsen some environmental problems through increased use of abiotic resources and emissions of toxicity substances. Whether electric vehicles truly do reduce global warming impacts also depends on the production technology for the electricity. This type of ambiguous result calls for a systematic assessment of the environmental and resource performance of electromobility, such as by LCA. Considering the many overlapping issues related to LCA and electromobility, it can be thought of as a *nexus*, involving different technologies (batteries, fuel cells, electronics, electric motors, different vehicles, etc.) and different environmental issues (resource use, criticality thereof, energy-related emissions, etc.). In order to investigate which parts of this *nexus* are most interesting to study further, information was obtained from three sources: (1) workshops with relevant industry stakeholders, (2) interviews with researchers in the field, and (3) a literature study of key documents in the area of LCA of electromobility. The result is formulated into a research agenda for LCA of electromobility, which consists of ten research questions. Seven of these regard electromobility technologies important to study (e.g. future battery chemistries and electric aviation), whereas three regard methodological issues (e.g. impact assessment of abiotic resources). Two near-term research projects have been formulated, for which funding applications will be submitted during 2019, and together they cover a majority of the research questions.

Background

The electrification of vehicles (i.e. electromobility) has the potential to lead to considerable reductions of greenhouse gas emissions and other pollutants from transport because of the termination of direct dependence on combustion of fossil fuels. Electric propulsion is more energy efficient than combustion-based propulsion and an electric vehicle gives off no tailpipe emissions (although possible wear and tear on roads and tires for land-based vehicles). However, in order to truly reduce greenhouse gases as well as other emissions, and not just ‘export’ them to other sectors, an electricity production with low environmental impacts is required. This can be achieved through flow-type renewable energy sources, such as solar and wind power (Nordelöf et al. 2014). At the same time, large-scale implementation of electric vehicles could require increased electricity production. Furthermore, the electric powertrain consists of components that are complex from a material point of view and electrification of vehicles might lead to an increased use of scarce and/or critical materials. Although recycling has been pointed out as a possible potential remedy for such material use, the recovery of other metals besides that of steel, aluminum, copper and platinum is negligible in current recycling of cars (Andersson et al. 2017). The main environmental and resource impacts of a vehicle might thus unintentionally become shifted from the use phase (for combustion engines) to the production of components and materials (for electric vehicles) in the vehicle’s life cycle.

Trade-offs related to environmental impact and resource use, such as those described in the previous paragraph, might thus arise during the implementation of electric vehicles in society. Such trade-offs can be fruitfully addressed by applying a life-cycle perspective, specifically through life cycle assessment (LCA) (see description below). Since the technological area of electromobility undergoes continuous change and upscaling, often based on environmental arguments, there is a corresponding need for continuous environmental and resource guidance. Guidance by LCA can be used for a number of purposes, including as a basis for technology development, product development, policy making and regulation. For companies, such guidance may reduce risks connected to the availability of critical materials, and at the societal level, it may contribute to a more circular economy.

This work is inspired by the concept of a *nexus*, as for example in the *nexus* between bioenergy and water use (Gheewala et al. 2011). A *nexus* can be described as a number of different domains interconnected into a central or focal point. Considering the many linkages between LCA and electromobility, an initial *nexus* between these two entities was envisioned. It contains aspects related to technology domains relevant to study (such as batteries and fuel cells), important stages in the life cycle (such as recycling and energy production) and environmental issues (such as emissions and resource use). Figure 1 provides a schematic illustration of this *nexus*. In this report, the idea is to provide more content to substantiate the picture and eventually formulate a research agenda for how to study this *nexus* in more detail and where to focus efforts. Before the project is described in more detail however, the reader is introduced to the two main entities of the *nexus*: electromobility and LCA.

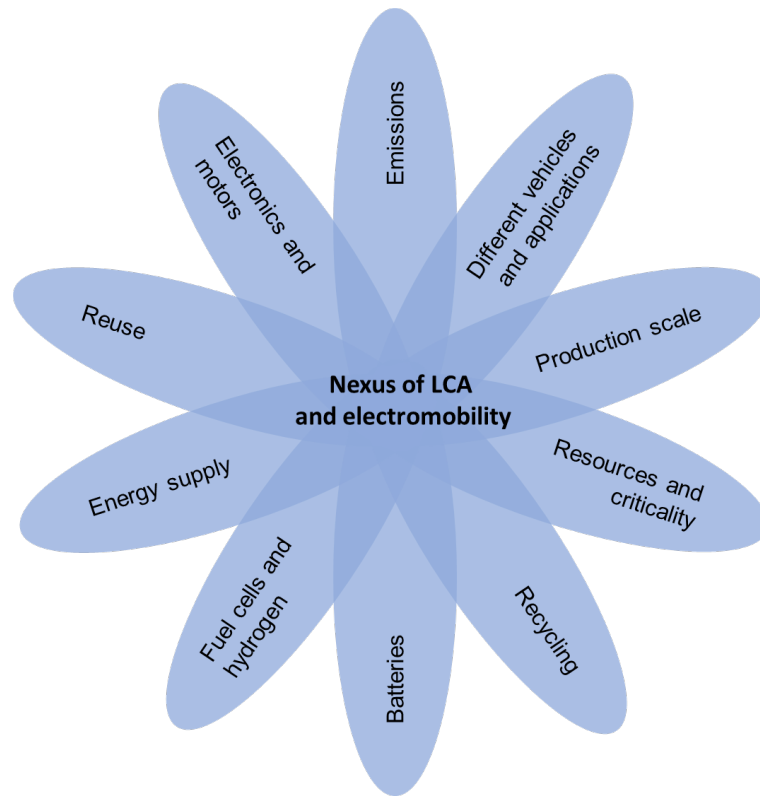

Figure 1. Illustration of the *nexus* between LCA and electromobility.

Electromobility

Electric propulsion of road vehicles, as well as other vehicle types such as boats and aircrafts, can be realized through several different powertrain configurations. Regardless of the exact solution, the powertrain must contain a set of components that includes at least one electrical machine to provide motoring and generating capacity. As in conventional powertrains, there is often a mechanical power path to the wheels, including gears and shafts. There is also a need for portable energy storage to provide electricity, most commonly a battery (Husain 2011). Batteries can be made to facilitate external charging using electricity from the grid, referred to as ‘plug-in’, or by charging only within the vehicle itself, for example by brake energy recovery. Among several different types of rechargeable batteries, lithium-ion technology has grown to become the dominating type for the electrification of vehicles (Zubi et al. 2018). The choice of specific battery size and design (including the selection between different chemistries) depends on the desired operating range, as well as on how it is charged and used (Corrigan and Masias 2011).

Fuel cells, which generate electricity electrochemically from a fuel stored in a tank, typically hydrogen, are another solution for providing the required on-board energy, either for charging the battery or for direct use in propulsion (Husain 2011). As with batteries, there are several different types available, but polymer-electrolyte membrane (PEM) cells are often judged as most suitable for mobile applications (Husain 2011). Two critical factors for the deployment of fuel cells are the production and storage of hydrogen. Common methods for producing hydrogen include steam reforming of natural gas and electrolysis of water using electricity (Cetinkaya et al. 2012).

As indicated by Figure 2, a schematic overview of the main components of the electric powertrain, different power electronic converters play an important role in the electric powertrain. The term ‘converter’ refers to an electronic circuit containing

semiconductor switches that can convert electrical energy from one voltage level and frequency to another. In vehicles, converters are used to control electrical machines, to modify voltages and to shift between different types of current, i.e. from alternating current (AC) to direct current (DC) and vice versa. Inverter units, one of three converter types used in electrically propelled vehicles, are primarily used for controlling electrical machines, but also enable storage of brake energy by rectifying AC from the motor. The other two types are DC/DC converters and on-board chargers. Externally-charged electric vehicles contain at least one converter of each type, often more (Çağatay Bayindir et al. 2011; Emadi et al. 2008), but the final number of converter units depends on how many motors are installed, auxiliary demands and whether the electric powertrain is combined with a conventional powertrain in a hybrid system.

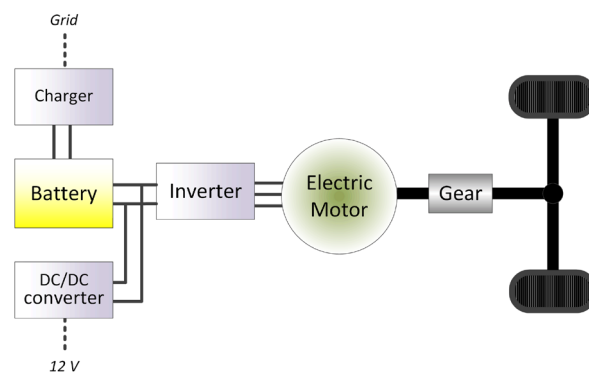

Figure 2. Schematic drawing of a basic setup for an automotive electric powertrain. Obtained from Nordelöf (2017).

Power electronic converters also play a key part in charging infrastructure for electric vehicles, both in typical home charging units and in fast-charging stations, for common static conductive power transfer. Together with large coils or conductor rails and new road design, they are also functioning in more advanced charging solutions under development, with Sweden as a global frontrunner. For example, a static wireless (inductive) power transfer is being tested for city buses in Södertälje (Scania 2016). Various dynamic electric road systems are also under development within Sweden, with ongoing tests of (conductive) overhead catenaries (Sandviken), and various in- or on-road tracks (Gothenburg, Arlanda, Lund) (Alaküla and Márquez-Fernández 2017) and a wireless (inductive) test site in Visby (SmartRoad Gotland 2019).

Life cycle assessment

LCA is a framework for assessing environmental and resource impacts of products and services, and consists of four phases (ISO 2006). The first phase is the goal and scope definition, in which the reason for conducting the study and the expected audience are described. These aspects will then influence methodological choices throughout the LCA study (Tillman 2000). The definition of a so-called system boundary delimits the studied product system to include a specific set of processes, which may represent a part of, or the full life cycle of a product. This is illustrated by the two dashed boxes in Figure 3. The different life cycle scopes that these system boundaries define are referred to as cradle-to-grave (the larger box) and cradle-to-gate

(the smaller box), respectively. Cradle-to-gate includes raw material extraction and production of a product, whereas cradle-to-grave also includes the use and end of life of the product. Furthermore, the functional unit is defined in the goal and scope definition. This being a unit to which all environmental and resource impacts are related. In the context of electromobility, a typical functional unit could be 1 km driven by an electric vehicle or 1 kWh energy stored in a battery.

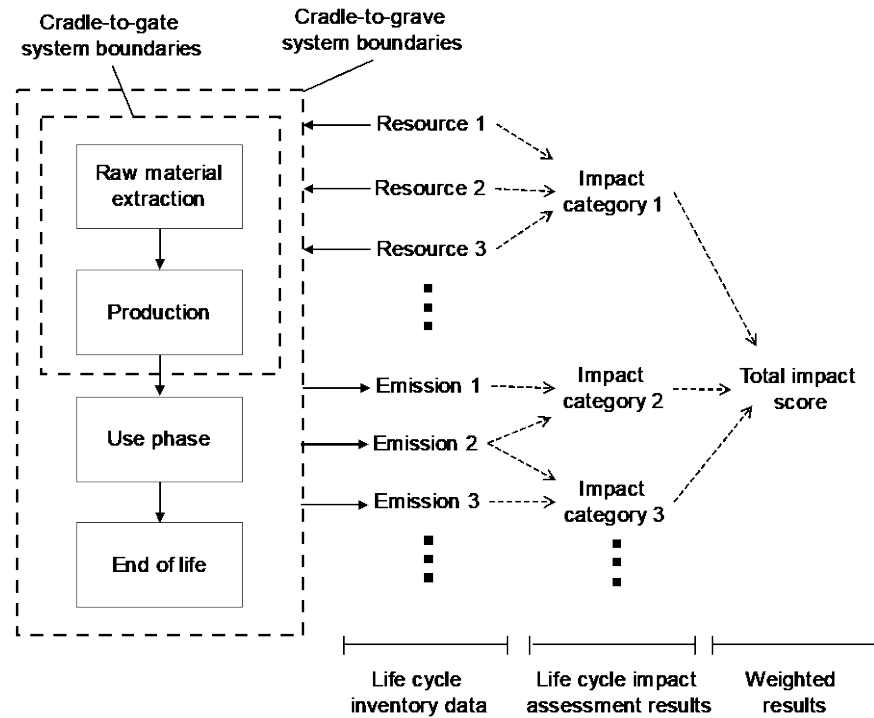

Figure 3. Graphical representation of some key concepts in LCA. Solid arrows represent material and energy flows, while dashed arrows illustrate the impact assessment procedure. Solid boxes represent processes and dashed boxes illustrate two possible system boundaries. Obtained from Arvidsson (2017).

The second phase of the LCA framework is the inventory analysis, in which data on input and output flows for the system defined in the goal and scope definition is gathered (Suh and Huppel 2005). These input and output flows are then related to the functional unit of the study. In general, the inventory analysis is the most time-consuming part of an LCA study. The outcome of this stage is an inventory table containing all identified inputs (e.g. water, energy and minerals), emissions (e.g. methane and particles), by-products (e.g. gallium from aluminum mining) and waste (e.g. mining overburdens and tailings). Such flows included in the inventory table are called elementary flows, whereas flows occurring within the product system are called product flows.

The third phase of the LCA framework is called life cycle impact assessment, in which the inventory data gathered is ‘translated’ into impact categories according to the following equation (Hauschild and Huijbregts 2015):

$$IS_j = \sum_{i,k,l} Q_{i,k,l} \times CF_{i,j,k,l}$$

In this equation, IS is the impact score, Q is the quantity of emissions or resources (i.e. an elementary flow), CF is the characterization factor relating the quantity to an impact category, i is a certain contributor to the impact category j , k is the location of the emission or resource use and l is the environmental compartment to which the emission occurs or from which the resource is extracted. Impact categories often considered in LCAs include climate change, acidification, eutrophication, ground-level ozone formation, depletion of the ozone layer, as well as human toxicity and ecotoxicity. Other commonly included impact categories, which are related to resource use rather than emissions, include energy use, land use and water use and sometimes, the use of abiotic resources such as metals and minerals.

The CF in the equation above determines how much a certain quantity of emission, or resource, contributes to an impact category. As illustrated in Figure 3, some emissions and resources can contribute to several impact categories, an example being nitrogen oxides, which cause both acidification and eutrophication. Although not commonly applied in LCA studies, different impact categories included in the impact assessment phase can also be aggregated into a total impact score, which is called weighting. Such weighting is always based on some kind of values, such as how the impact categories relate to policy goal or the economic value destroyed by the emissions and resource use (Finnveden et al. 2009).

The fourth phase of the LCA framework is called interpretation. Here, the inventory analysis and impact assessment results are put into context, a sensitivity analysis is conducted and conclusions are drawn from the study.

General project description

This project is financed by the Swedish Energy Agency (project number 47915-1) with the overarching purpose of meeting the need for continuous guidance and assessment regarding environment and resource impacts of electromobility. Specifically, the four aims of the project are:

1. To outline a nexus between LCA and electromobility
2. To investigate the state of knowledge for the different parts of the outlined nexus
3. Identify particularly interesting research questions within the nexus
4. Formulate a long-term research project that investigates and can answer the identified research questions, while also being able to consider new issues emerging over time

The first three aims will be addressed and fulfilled in this report. This will lead to a research agenda, which will provide a platform for the formulation of long-term research projects on LCA and electromobility, thereby also contributing to the fulfillment of the fourth aim. The time scope of this pre-study project has been January-August 2019.

Method

The three methods applied to fulfill the aims of the project are:

- Literature survey
- Interviews with researchers at the division of Environmental Systems Analysis, Chalmers University of Technology
- Workshops with industry stakeholders

These three methods are described in more detail in the following.

Literature survey

The literature survey departed from six acknowledged *key documents* discussing common issues related to LCA and electromobility, in particular methodological issues (Table 1). A clear focus on *both* LCA and electromobility, not just one of these topics, was a requirement for selection. The book chapter by Cerdas et al. (2018) is part of a prominent textbook on LCA. The two review papers by Hawkins et al. (2012) and Nordelöf et al. (2014) (the latter being previous work by one of the authors of this report) are frequently cited within the field. The two papers by Egede et al. (2015) and Ellingsen et al. (2017) are less cited but still discuss general issues related to LCA and electromobility. The paper by Frischknecht and Flury (2011) report findings and insights from a discussion forum on electromobility. These six documents were read carefully and issues of specific importance for LCA of electromobility were identified.

In addition, in order not to overlook any other significant documents, a wider search applying the search engine Scopus was also conducted the 4th of June 2019, using the following search string:

```
TITLE-ABS KEY ((electromobil* OR "electric vehicles" OR "electric vehicle") AND (LCA OR "life cycle assessment"))
```

This search resulted in a total of 468 documents identified, indicating a reasonably sized research field. The six pre-selected key documents were among these. Most of the others were LCA case studies, e.g. of specific electric vehicles or of specific regions. Such detailed studies are of limited relevance here, since they typically discuss issues related to the specific case.

However, despite their seemingly broad scopes, the six key documents are highly focused on cars. In fact, although a ‘vehicle’ technically may refer to any means of transportation, the term ‘electric vehicle’ has largely become synonymous with ‘electric car’. Therefore, in order to capture relevant literature about other types of vehicles, the following search string was also used:

```
TITLE-ABS KEY (electric AND (bus* OR truck* OR (heavy vehicle*) OR lorr* OR aviation* OR aircraft* OR ship* OR ferr* OR boat*) AND (LCA OR "life cycle assessment"))
```

This resulted in fewer (231) hits, with only a limited number of LCA case studies on different electric vehicles, such as electric buses (Cooney et al. 2013; Bi et al. 2015; Xu et al. 2015; Ercan and Tatari 2015; Bi et al. 2017; Song et al. 2018), electric trucks

(Lee et al. 2013; Liu et al. 2015; Lee and Thomas 2017; Zhou et al. 2017; Zhao and Tatari 2017; Yang et al. 2018) as well as, somewhat surprisingly considering the search string, an electric forklift (Fuc et al. 2016) and electric bicycles (Liu et al. 2015; Elliot et al. 2018). No case studies on electric aircrafts or ships/boats were found. A few studies of electrified roads were found, covering only certain parts of a complete electrified road system, such as the construction of electrified roads (Balieu et al. 2019). In addition, no additional documents covering general issues for LCA concerning electromobility were found from the second search string.

Table 1. Key documents selected for detailed reading in the literature survey.

Authors	Year	Title	Journal /Source
Cerdas et al.	2018	LCA of electromobility	Life Cycle Assessment: Theory and Practice
Egede et al.	2015	Life cycle assessment of electric vehicles – a framework to consider influencing factors	22 nd CIRP conference on Life Cycle Engineering
Ellingsen et al.	2017	Identifying key assumptions and differences in life cycle assessment studies of lithium-ion traction batteries with focus on greenhouse gas emissions	Transportation Research Part D
Frischknecht and Flury	2011	Life cycle assessment of electric mobility: answers and challenges	International Journal of Life Cycle Assessment
Hawkins et al.	2012	Environmental impacts of hybrid and electric vehicles – a review	International Journal of Life Cycle Assessment
Nordelöf et al.	2014	Environmental impacts of hybrid, plug-in hybrid, and battery vehicles – what can we learn from life cycle assessment?	International Journal of Life Cycle Assessment

Interviews with researchers

Two researchers from the division of Environmental Systems Analysis, Chalmers University of Technology, were interviewed together: Matty Janssen (associate professor) and Maria Ljunggren Söderman (PhD, researcher). They are involved in projects related to environmental assessment of electromobility and experts on environmental assessment in general (including LCA). Dr Janssen is currently involved in the following relevant project:

- “Second-use of Li-ion batteries from hybrid and electric vehicles,” financed by the Swedish Energy Agency, where he will assess the environmental performance of using spent lithium-ion batteries (LIBs) from electric cars for stationary energy storage in grids.

Dr Ljunggren Söderman is currently involved in the following relevant projects:

- “Electric traction motors in a circular economy,” where she uses LCA to provide guidance on how electric vehicle components can be adapted to circularity.
- “Mistra EXPLORE – Exploring the opportunities for advancing vehicle recycling industrialization,” where she will suggest ways to reach increased functional recycling of materials in vehicles.

In addition, a separate interview with Bengt Steen (professor emeritus) was held. Professor Steen has a long (~20 years) track record of involvement in projects related to LCA and electromobility, in particular focusing on environmental assessment of batteries and fuel cells. Recent examples include:

- “Integrated sustainability assessment of tomorrow’s battery concepts”, financed by the Swedish Energy Agency, where he assessed the environmental costs of emerging batteries.
- “Lithium sulfur superbattery exploiting nanotechnology” (LISSEN), financed by the European Commission’s FP7 program, where he assessed the environmental cost of nanostructured electrode and electrolyte materials for lithium-sulfur batteries.
- “Advanced, high performance, polymer lithium batteries for electrochemical Storage” (APPLES), financed by the European Commission’s FP7 program, where he assessed the environmental cost of a novel lithium-ion battery concept.

The first interview was carried out at the department and the second on Skype on the 22nd of August 2019, both in an informal, semi-structured fashion, with the initial question being “what are the most interesting issues related to research on LCA and electromobility?”

Workshops with industry stakeholders

Four workshop sessions were carried out with managers and specialists having strategic responsibility for electromobility within five different companies, constituting stakeholders in the areas of passenger cars (Volvo Car Corporation), heavy duty vehicles (HDVs) for commercial road applications (Scania CV AB), fuel cell systems (PowerCell Sweden AB), transoceanic shipping (Stena Bulk AB) and public utility of electric power (Vattenfall AB). These sessions were organized as guided discussions where the participants were asked to describe the company’s view on knowledge gaps regarding the sustainability of electromobility. Three different questions, with each of these allotted to a set of suggested focus areas for future research, were taken as a starting point:

1. Which life cycle phases are most important to investigate?
 - (a) Materials extraction
 - (b) Manufacturing (including effects of upscaling)
 - (c) Use or reuse
 - (d) Waste handling and recycling

2. Which technologies or applications are most important to investigate?
 - (a) Complete vehicles (which types?)
 - (b) Charging infrastructure (static)
 - (c) Batteries
 - (d) Fuel cells
 - (e) Electric road system (dynamic)

3. Which environmental impact is most important to focus on?
 - (a) Climate change
 - (b) Resource use
 - (c) Air pollution
 - (d) Other

Each question and area were then discussed, as well as additional questions and research topics proposed during the workshop, and in the end judged in terms of importance. Table 2 reports the details of workshops with the industry stakeholders, in terms of dates, meeting format, participants and their titles, as well as the company they represent.

Table 2. Summary of participants and sessions for the industry workshops.

Date	Format	Name and title	Company
8 th of May 2019	Skype meeting	Fernanda Marzano, <i>Technology Leader Electrification</i> Dora Burul, <i>Development Engineer Sustainability</i>	Scania CV AB
20 th of May 2019	Face to face meeting	Hans-Göran Milding, <i>Strategy Director</i> Hanna Persson, <i>HV Battery Program and Strategy Manager</i> Hanna Bryngelsson, <i>Senior Strategist Electrification</i>	Volvo Car Group
14 th of June	Face to face meeting	Per Ekdunge, <i>Chief Technical Officer</i>	PowerCell Sweden AB
		Erik Möller, <i>Business Intelligence Manager</i>	Stena Bulk AB
26 th of June	Skype meeting	Gustav Frid, <i>Strategic Environmental Advisor</i>	Vattenfall AB

Results

Results from literature survey

In a book chapter about LCA of electromobility, Cerdas et al. (2018) provides an introduction to the field. They also highlight the challenges of defining a relevant functional unit for comparing electric vehicles and conventional vehicles. For urban, short-distance transportation, the two technologies can be considered roughly equal, whereas for long-distance transport, the more limited driving range of electric vehicles influences their function, presumably experienced as a limitation by users.

Furthermore, they highlight the importance of the electricity production mix for charging, exemplifying the notable difference in environmental impact from applying either solar or coal power. Arguing that comparability between studies is important, they recommend that studies conducted within the European Union should apply an average European electricity mix, in line with the eLCAr guidelines (Del Duce et al. 2013). Finally, the challenges of modelling recycling are highlighted, in particular for emerging technologies such as vehicle batteries, since recycling processes might not yet exist.

Egede et al. (2015) present a framework for considering influencing factors in LCAs of electric vehicles. It consists of (1) the vehicle's energy consumption, (2) internal factors such as the production of the vehicle and its components, and (3) external factors, which are put in focus in the paper. In turn, the external factors can be divided into three subcategories: (1) surrounding condition (climate, topography and type of road), (2) user (comfort, driving style, charging behaviour) and (3) infrastructure (electricity production mix, charging system, smart charging). Most of these factors exert a major influence on the electricity demand for operation and subsequent environmental impacts from electricity production. The charging infrastructure is also highlighted, both in terms of environmental burden from its production and use, as well as how it might facilitate the technology diffusion of electric vehicles.

The review by Ellingsen et al. (2017) is focused on LCA of LIBs for use in electric vehicles. They highlight that the reviewed studies report highly varying energy requirements for battery production and related climate change impacts. Cell production ranged from less than 1 to more than 1000 MJ/kWh, pack assembly from less than 1 to 400 MJ/kWh and the combined production energy requirement (cell + pack) from less than 1 to more than 1300 MJ/kWh. Such profound differences point at the importance of improving and consolidating inventory data sources for battery production. Since some recent studies have been based on industry data rather than estimates, the authors report a tendency towards improved data quality over time. Furthermore, they report large uncertainties associated with the modelling of battery recycling due to lack of industry data.

Frischknecht and Flury (2011) provide a report from the 43rd Discussion Forum on LCA held in Zurich, which focused on electromobility. Hence, it represents relatively early insights into the *nexus* and the main output was a short list of aspects important to the environmental burden of vehicle electrification:

- Weight of the car
- Battery production and performance
- Electricity production mix for charging the battery
- Technology dynamics
- Societal dynamics

With ‘technology dynamics’, they refer mainly to improvements in battery production and performance but also to improvements in traditional combustion engines. With ‘societal dynamics’, they refer to reduction in the demand for mobility, shift to alternative and combined mobility concepts as well as shift from cars as status symbols to clean cars.

Hawkins et al. (2012) conducted the first major review on LCAs of electric and hybrid vehicles. They noted that the completeness of scope is limited for most LCA studies of electric vehicles and, in particular, the production of electronics and recycling are excluded from a significant share of the studies. Similarly to Ellingsen et al. (2017), they also found a considerable variation in the climate change impacts of battery production between studies. Similar to previous key documents, the paper also highlights additional topics: the energy demand of the use phase, the electricity production mix for charging and the end-of-life stage, including recycling. In addition, a number of steps towards improving the understanding of the environmental impacts of electric vehicles are provided:

- Obtain good estimates for use-phase electricity requirement
- Improved data on vehicle lifetimes and battery replacement schedules
- Develop transparent, rigorous and publicly available LCIs for electric vehicles
- Quantify the influence of different end-of-life scenarios

Finally, they recommend tracking the fate of toxic materials contained in the batteries of electric vehicles.

The third review by Nordelöf et al. (2014) brings up the importance of the goal and scope definition, pointing out that differences in purposes might rightfully result in, and partly explain, different numerical results. They also highlight three important aspects for the environmental impacts of electric vehicles: degree of electrification (e.g. battery, plug-in, hybrid), the electricity production mix and driving mode (city, suburban, highway). Another issue pointed out is the use of different functional units in the reviewed studies. While these issues are in line with the previous key documents, the review by Nordelöf et al. (2014) then puts more focus on the LCIA phase, thus going beyond climate change and energy use. In particular, they discuss the challenges of assessing mineral (or abiotic) resource use in LCA, for which there are several different methods, some lacking characterization factors for important metals such as rare earth elements. They also comment that toxicity impacts, where electric vehicles might have higher impacts than combustion engine vehicles, is an impact category associated with high uncertainty. Finally, they note that in 100% of the reviewed studies the modelling of recycling was a key factor for the result, while real-world recycling remains a challenge.

Results from interview with researchers

Professor Steen brought up the following issues related to LCA of electromobility:

- The sensitivity and uncertainty of inventory data, characterization factors and weighting factors should be considered.
- Regarding inventory data, the net extraction of resources is most uncertain due to uncertainties in open-loop recycling and material downgrading.
- Regarding characterization factors, a main uncertainty lies in the climate change impact of carbon dioxide due to the unknown effect of low clouds.

- Regarding weighting factors, the main uncertainty lies in how to evaluate abiotic resources, such as lithium.
- There are three major electromobility trade-offs to be investigated with LCA: electric vs fossil fuel vehicles, electric vs bio fuel vehicles and electric vs other electric vehicles.
- Regarding life-cycle phases, recycling is a particularly important subject to study further.
- Considering the resource-related issues of LIBs, it is particularly important to evaluate emerging battery technologies (based on more abundant metals).
- Regarding environmental impacts, it is important to develop improved impact assessment methods for abiotic resources. And it is important to monitor progress in the field of climate change research continuously.

A number of other issues were highlighted by Dr Janssen and Dr Ljunggren Söderman:

- The importance of second use for batteries when assessing their environmental impacts.
- The importance of the battery life time and thus the importance of obtaining accurate data for that parameter in LCAs of electric vehicles.
- The increased use of lightweight materials occurring in parallel with electrification.
- The importance of also considering other environment assessment tools for assessment electromobility, such as material flow analysis.

Results from workshops with industry stakeholders

The discussion points and environmental areas of concern that the industry participants declared to be most important for the future development of electromobility are summarized in bullet form per session in this section.

Session 1, Scania CV AB:

- The overall most important issue is to understand the long-term potential for the sustainability of different technology pathways for HDVs.
- Climate change is the key driver for electrification, and especially for this impact category it is also important to continuously monitor the short-term effects of improvements in material extraction, more efficient manufacturing and new recycling procedures, for all powertrain components, but foremost for batteries.
- Among promising technology pathways for HDVs, the largest knowledge gaps exist in comparisons between:
 - Different types of electric road solutions, especially on the transport system level where possibly both HDVs and passenger vehicles could be included.
 - Different battery solutions and hydrogen production routes combined with fuel cells for HDVs.

Session 2, Volvo Car Group:

- Reducing environmental impact is “as important as the safety belt” for the car industry. Current environmental issues are of global scale and coming research and knowledge dissemination must support a route towards technical solutions with potential to achieve countermeasures on a similar scale, i.e. sort out the technologies that have both sufficient mitigation effect and will work on all markets.
- It is important to monitor the development of electromobility in order to:
 - Provide feedback to policy makers about the effects of environmental legislation.
 - Promote charging with, and purchasing of, low-carbon electricity, to show benefits and effects of progress in electricity generation.
 - Communicate progress in battery production, learn about specific energy-demanding steps, such as the formation process (the final step of cell manufacturing), and obtain well-informed answers.
- Specific research areas for LCA of high interest are:
 - How do battery electric vehicles (BEVs, i.e. all-electric cars) and plug-in hybrid electric vehicles (PHEVs) compare on different markets?
 - What should be the strategy for recycling of LIBs – directly after vehicle life or after a shorter use in the vehicle combined with a second life in a stationary application (taking into account rapid technical development, vehicle upgrading, etc.)?
 - How do new in-vehicle energy consumers and new driving patterns by automation (with a shift towards more commercial routes and driving patterns) influence the environmental effects of electrification?
 - What are the benefits and drawbacks of aiming for electric road solutions that allow for the connection of passenger cars along with HDVs, compared to HDVs only?
- There is a need for more in-depth understanding of the environmental impacts of electrical machines and power electronics.
- Fuel cells are currently not in focus at the moment, but remain interesting in the long term.
- Climate change mitigation is the driver for electrification, resource availability is a possible constraint and the reduction of local air pollution is a benefit.

Session 3, PowerCell Sverige AB and Stena Bulk AB:

- Areas of specific relevance for fuel cell systems are:
 - Resource availability (platinum), material production and recycling of stacks.

- What would be the effect of electrode material substitution from platinum to carbon-based nanomaterials?
 - LCA of different pathways for hydrogen production.
 - LCA of different storage options for hydrogen, for example liquid organic hydrogen carriers.
- The shipping industry must develop zero-emission propulsion systems over a period of the three next decades. An initial research agenda addressing the specific knowledge gaps for trans-oceanic ships should aim to screen different candidate technologies and search for trade-offs, for example by comparing a fuel cell system using hydrogen to flow batteries.
 - At this stage, well-to-wheel studies can be expected to be useful both for fuel cell systems and ship applications when complete LCA is too time consuming or lacks data, for example when investigating carbon capture during hydrogen production for fuel cell systems.

Session 4, Vattenfall AB:

- Batteries play a central role in the strategy of utilities and some of the key areas of interest for electromobility are:
 - Projections of future emissions from the complete battery production chain for different options in terms of capacity and life length.
 - Potential sustainability of different battery chemistries.
 - The effect of second life usage on the environmental burden of LIBs assigned to the first life in a mobility application.
 - Investigation of material extraction impacts, including societal impacts as assessed by social LCA, and the availability of critical materials for batteries, with specific focus on copper, cobalt and nickel.
- Grid storage and buffering can enable increased availability of renewable electricity for charging electric vehicles, both in the short term and in the seasonal. But more knowledge is needed when prioritizing between options, for example flow batteries or hydrogen production combined with fuel cell systems.
- Loss of biodiversity is an important environmental problem, which must be evaluated alongside effects of climate change.

Discussion

The results described in the section above touch upon a number of common themes within the *nexus*. Figure 4 aims to capture most of these reoccurring themes using the life-cycle model. One frequently mentioned theme is batteries, specifically LIBs, where current research efforts both in terms of technology development and assessments have been relatively large. Even so, due to rapid changes of battery design and processing technology (IEA 2016), more detailed and updated LCA studies surveying emissions caused by the complete battery production chain and different recycling schemes are continuously needed in order to monitor and guide this development. This was pointed out by several of the industry representatives (foremost Scania, Volvo Cars and Vattenfall). Thus, while some knowledge gaps related to the use phase that were pointed out in the early literature (i.e. electric vehicle energy consumption and the need for battery replacements) have seen the state of knowledge becoming improved, other life-cycle stages remain comparatively unstudied and challenging for the *nexus* of LCA and electromobility. For batteries, these other life-cycle stages include, in particular, material extraction, cell manufacturing, which is facing upscaling, and the end of life, where new processes are under constant development (Dunn et al. 2015). In this respect, it is notable that an electrification of construction equipment vehicles in mining can contribute to a reduction of emissions for the extraction of metals for electromobility. At the same time, better knowledge of actual battery life length has opened up opportunities for new questions of reusing the batteries in second-life applications, i.e. extending the use phase. The need for addressing the environmental burden of different such reuse scenarios, which have so far been studied in a few LCA studies only, see for example Vandepaer et al. (2019), was pointed out both by industry representatives and researchers. One example could be the reuse of car batteries in stationary energy storage, as in an ongoing project by Dr Janssen (“Second-use of Li-ion batteries from hybrid and electric vehicles”).

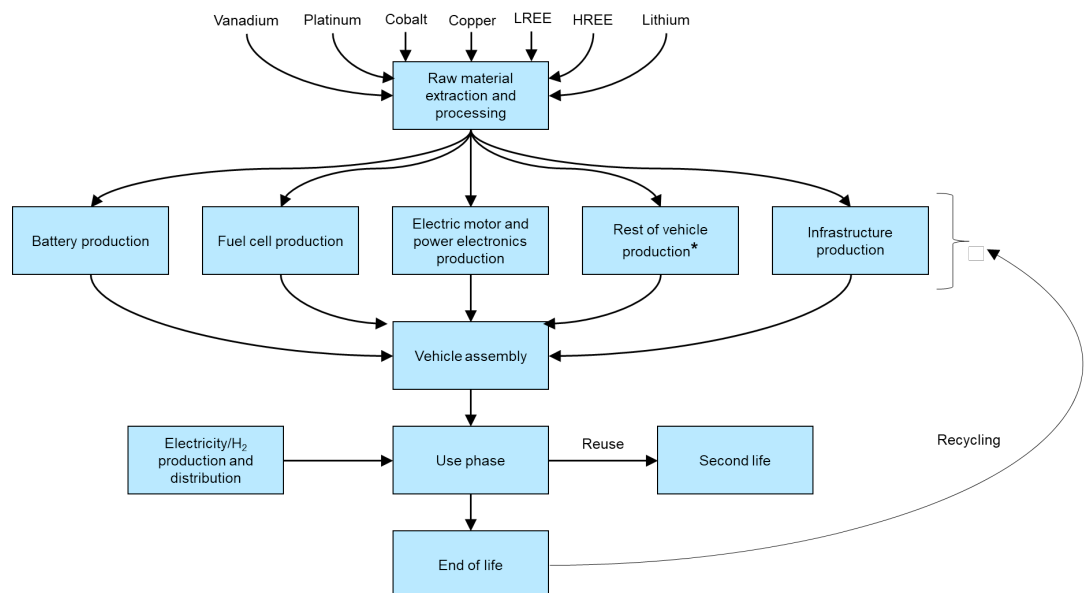

Figure 4. Illustration of the life cycle of a generic electric vehicle with the environmentally most important processes and flows shown. LREE=light rare earth elements, HREE=heavy rare earth elements. *Note that ‘vehicle’ here includes cars, trucks, aircrafts, ships, etc.

Several of the reviewed key documents point to the GREET (Greenhouse gases, Regulated Emissions, and Energy use in Transportation) model, i.e. an LCA model created and updated by the Argonne National Laboratory under the United States Department of Energy, as being ‘state of the art’ in terms of inventory data for LCA of electromobility. In competition (or together) with the largest commercially available and well-documented international LCA database, the Swiss Ecoinvent database (Weidema et al. 2013; Wernet et al. 2016), the GREET model is used in many LCAs of electromobility (Cerdas et al. 2018; Hawkins et al. 2012). However, both these two leading data sources have limitations. GREET is a ready-to-use model which is regularly updated, but a downside is that the user must operate in a partly predefined technology context and methodological setup. The Ecoinvent database, on the other hand, provides a large amount of unit process datasets, which can be used to create LCA models in any area of technology (Wernet et al. 2016), including electromobility. However, the purpose is to provide generic background-system data, while the foreground system in LCA studies of specific technology, including electromobility (e.g. of LIB manufacturing or recycling), should preferably be modeled using technology-specific and more detailed data in order to provide accurate results and relevant guidance for involved stakeholders. In fact, our own previous research has exemplified inconsiderate and uncritical use of technically invalid data both for electric motors and power electronics within the research field, with a linked risk of presenting misleading results (Nordelöf and Tillman 2018; Nordelöf et al. 2019a). Consequently, even with these two key data sources available, i.e. the GREET model and the Ecoinvent database, there is a need for research going beyond their limitations with in-depth technical studies to provide continuous updated information about the environmental burden of explicit powertrain components, charging equipment, and complete vehicles of various different types, as well as methodology development aimed specifically at LCA of electromobility, to properly monitor the ongoing development in the area (Hawkins et al. 2012; Del Duce et al. 2014).

Resource scarcity is another theme brought up by the researchers and all industry representatives interviewed as key areas for research in connection to electromobility. Relevant metals include lithium (e.g. for LIBs), copper (e.g. for electric road conductors), cobalt (e.g. for LIBs), nickel (E.g. for LIBs), heavy and light rare earth elements (H- and LREEs) (e.g. for electric motors), platinum (e.g. for fuel cell electrodes) and vanadium (e.g. for redox-flow battery electrolyte). The long-term demand for and availability of different metals relate to both their geochemical scarcity and to the diffusion and setup of different technology pathways; for example the metal content of electric road infrastructure, future batteries and fuel cells. This is strongly linked to the possibility of substituting rare for more abundant materials and the ability of the recycling system to recover the material back to original quality at a minimum of loss. Indeed, a number of battery chemistries are currently under development, where arguments of lower metal scarcity issues are a main driver, including for example aluminium (Jayaprakash et al. 2011) and calcium (Ponrouch et al. 2015) batteries. For the *nexus* of LCA and electromobility, this involves a number of research topics of high relevance for the future. These are either sparsely researched or rapidly changing due to ongoing development. One topic is comparisons between different battery types regarding their resource impacts, as highlighted by professor Steen in particular. Another is trade-offs between benefits in the use phase of electric vehicles *versus* resource impacts of different battery chemistries, or electrode materials for fuel cells. Yet another topic of high relevance, which is largely unaddressed in existing LCA studies, is the long-term sustainability of different electric road technologies in terms of metal use, for example depending on the amount of copper needed to provide proper functionality for different solutions. Common to all these questions are their prospective nature and the need for framing LCA studies in the context of different scenarios for the future transport system, which in terms of

research requires both advanced scenario modelling and the development of methods suitable for prospective LCA. Prospective LCA approaches that can be applied when assessing electromobility have been proposed by the authors of this report (Arvidsson et al. 2018) and also by others (Villares et al. 2017; Cucurachi et al. 2018), but these approaches require further development. Also, in the context of unresolved methodological issues, it is important to mention that there is no consensus in the broader LCA research community on how to best evaluate abiotic (e.g. metal) resource depletion, only that further research is needed (Sonderregger et al. 2017).

Furthermore, related to potential recycling, if circular flows of materials are to become a dominating source of input for the production of future electromobility technologies, currently emerging recycling procedures should be evaluated by LCA in order to minimize their emission burden and ensure a net resource benefit. At the same time, there are indications that the LCA of electromobility research field has been outpaced by recycling technology progress – current challenges for recycling are exaggerated by recent claims that recycling processes for electric vehicles do ‘not exist’ (Cerdas et al. 2018). However, sources from outside the LCA field suggest there is ongoing and rapid development of recycling activities for LIBs, in particular in China and South Korea (Melin 2019). Research conducted by the authors of this report indicates that a main challenge is instead methodological: how to model such existing (although still developing) recycling procedures in a manner which leads to relevant and easily interpreted LCA results (Nordelöf et al. 2019b). This is especially important since the interdependence and dynamics between more efficient production of LIB cells and improved recycling is an area where several of the interviewed industry representatives expressed a need for more knowledge.

It is notable that the key documents reviewed regarding electric vehicles have such a strong focus on road-bound vehicles, i.e. foremost electric cars and to some extent electrified buses and trucks. Some of the industry representatives feel that the *nexus* of LCA and electromobility must be broadened to answer relevant questions for the entire transport system. For example, there is an increasing interest in electric aviation, often with the hope of environmental improvements relative to today’s conventional, fossil-driven aircrafts. Consequently, there is a need for information about the environmental performance of electric aircraft. Also, ongoing electrification of short-distance ferries and boats based on batteries is likely to overlap with research results for land-based vehicles, but these overlaps remain to be shown. Similar to aviation, transoceanic shipping is an area which is technically very challenging to electrify, but which nevertheless must reduce emissions and is an area where industry actors now actively search for technology pathways that can be implemented in the future. For all these non-car vehicles, LCA can make important contributions to guiding their electrification.

Finally, fuel cells constitute a technological pathway that is different from, and partly complementary to that of batteries and which has now re-entered the discussion on sustainable transportation system after a period of less interest. This was illustrated by the fact that all industry representatives expressed interest in fuel cells, although batteries represent the most discussed energy provision technology in the reviewed literature. Different technology developments related to electrode materials and hydrogen storage would benefit from environmental guidance by LCA. In addition, at a more over-arching level, environmental comparisons between fuel cell-based solutions and batteries for different applications (e.g. HDVs, aviation and transoceanic shipping) would provide valuable new knowledge and reveal the environmental and resource potential of fuel cells in an electrified transportation system.

Research agenda for LCA of electromobility

Based on the results and discussion above, a research agenda for LCA of electromobility can be formulated. The agenda consists of a list of ten broad research questions that can be answered by continued LCA efforts:

1. What is the impact on climate change, resource use, and local and regional pollution of LIB production, in particular considering upscaling of factory size and continuous cell design development?
2. What is the impact on climate change, resource use, and local and regional pollution impacts of LIB recycling, in particular of the ongoing recycling in leading markets but also technologies under development?
3. What is the impact on climate change and resource use of novel, promising battery chemistries, such as calcium and aluminum batteries?
4. What is the impact on climate change and resource use of electric aviation, depending on if this is based on LIBs or fuel cells fueled with hydrogen?
5. What is the impact on climate change and resource use of electric propulsion of ships, depending on if this is based on flow batteries or fuel cells fueled with hydrogen?
6. What is the impact on climate change, and which are the resource constraints of different conductive and inductive implementations of electric roads?
7. What is the impact on climate change and resource use of different fuel cell designs aimed for electrified vehicles, in comparison to LIBs, including the different pathways for energy transfer (i.e. direct electricity use and producing and storing hydrogen)?
8. How should the abiotic resource performance of electromobility technologies preferably be assessed in LCA, and in particular for important enabling metals such as lithium, copper, cobalt, nickel, HREEs, LREEs, platinum and vanadium?
9. How should recycling and reuse in second life of batteries preferably be modeled in LCA to provide useful guidance for stakeholders?
10. How should novel electromobility technologies, such as novel battery chemistries and recycling processes, preferably be prospectively modeled in LCA?

The seven first research questions concern different electromobility technologies of high relevance to assess in LCA studies. The three last questions are methodological issues that need to be addressed in order to conduct relevant LCA studies of the seven technologies. Based on the research questions in the agenda, various research projects can be formulated. In the section below, a number of such projects are described.

Utilization of results

The purpose of this project has been to formulate a research agenda for the *nexus* of LCA and electromobility, where the knowledge sought will support and guide future research and innovation within the electromobility area, thereby accelerating an electrification of the transport sector, which can be sustainable in the long term. Consequently, the primary utilization of project results will be to use the agenda as a

basis for formulating specific research projects and to apply for funding for their execution.

In the near term, i.e. during the remainder of 2019, the aim is to write and submit two applications:

1. PhD student project within the Swedish Electromobility Centre which aims to:
 - a. Investigate the impact on climate change, resource use, and local and regional pollution of LIB production for different factory scales and different cell geometries (1st half of project). This will make a substantial contribution to research question 1.
 - b. Investigate the impact on climate change, resource use, and local and regional pollution of LIB recycling, focusing on existing and upcoming recycling technologies with high potential for material recovery (2nd half of project). This will make a substantial contribution to research question 2.

2. A main project application for “A *nexus* for life cycle assessment of electromobility” within the “Uppdrag att stödja forskning och innovation inom elektromobilitet” program – the same program that has funded this pre-study project. It will involve work on three separate tracks with a further aim to formulate PhD student and post-doc projects within one or two of these tracks when further in-depth questions have been identified:
 - a. Investigate the impact on climate change and resource use of electric aviation based on LIBs. This will make a substantial contribution to research question 4.
 - b. Investigate the impact on climate change, resource use and constraints of at least two selected technologies for conductive or inductive implementations of electric roads. This will make a substantial contribution to research question 6.
 - c. Investigate the impact on climate change and resource use of electric propulsion of transoceanic ships, depending on if this is based on flow batteries or fuel cells fuelled with hydrogen, including screening of different pathways for storing and producing hydrogen. This will make a substantial contribution to research question 5.

Intertwined within these two applications will be methodological contributions related to research questions 8-10 concerning abiotic resource assessment, recycling/reuse and prospective LCA, respectively.

An additional application related to climate change, resource use and local and regional pollution impacts of novel battery chemistries (research question 3) is also planned for 2020 or beyond. This will make a substantial contribution to research question 3.

SEC targets and research program relevance

Contribution to Swedish Electromobility Centre targets

The mission of the Swedish Electromobility Centre (SEC) is to develop strategically important knowledge and expertise in the areas of electric propulsion for hybrid and electric vehicles and the infrastructure required for electricity supply and charging. One particular aim is to act as a support and partner to the Swedish automotive

industry, both original equipment manufacturers and their suppliers. Another primary purpose is to present a holistic view of the benefits and challenges of different technology pathways in order to meet the demands of a future society.

More specifically, ‘Electromobility in Society’, i.e. the theme that this project has been associated with, is based on the life-cycle perspective. Not only in studies of environmental impact, but more broadly. The research questions presented in the previous section are well aligned with the scope of this theme because they include the full life cycle of the components or subsystems fundamental to particular electromobility applications, covering both design requirements for circular material flows and monitoring the impacts of manufacturing, use, reuse and eventually recycling.

Research program relevance

The “Uppdrag att stödja forskning och innovation inom elektromobilitet” program supports projects that can contribute to a rapid electrification of the transport sector. Among the program’s designated research areas, the following have been taken into account in this pre-study of the *nexus* between LCA and electromobility: batteries, fuel cells, electrical machines, charging infrastructure, power electronics, system solutions, material recycling and LCA, this being the best-established tool in the environmental systems analysis toolbox (Ness et al. 2007).

When formulating the reported research agenda, and with the aim to step-by-step work through and further develop these questions in forthcoming projects, we argue to strongly support and provide important guidance for a fast development and deployment of new technology in the electromobility area. More specifically, studies of specific components, such as different chemistries and production methods for batteries, support knowledge building for many types of electrified vehicles, including road-based cars, trucks and buses, as well as construction equipment. Furthermore, pioneering LCA studies of aircrafts and trans-oceanic ships will address industry and technology areas not yet supported by any sustainability guidance.

Looking closer at the different types of projects that the program aims to support, addressing the *nexus* of LCA and electromobility will contribute to the goals of both “syntheses” and “modelling”. LCA studies build knowledge about current state-of-the-art technologies while also pointing out knowledge gaps and important areas for improvement in line with the goals of syntheses. However, it is important to point out that LCA inherently implies modelling, where the rigor and quality of the model determines how it can be used. Thus, systematic data collection for electromobility technologies and development of new methodology are necessary steps in order to build LCA models that can provide relevant information for guidance towards sustainable electromobility.

References

- Alaküla, M. and F. J. Márquez-Fernández. 2017. Dynamic charging solutions in Sweden: An overview. Paper presented at 2017 IEEE Transportation Electrification Conference and Expo, Asia-Pacific (ITEC Asia-Pacific), 7-10 Aug. 2017.
- Andersson, M., M. Ljunggren Söderman, and B. A. Sandén. 2017. Are scarce metals in cars functionally recycled? *Waste Management* 60(Supplement C): 407-416.
- Arvidsson, R. 2017. Review of environmental life cycle assessment studies of graphene production. *Advanced Materials Letters* 8(3): 187-195.

- Arvidsson, R., A.-M. Tillman, B. A. Sandén, M. Janssen, A. Nordelöf, D. Kushnir, and S. Molander. 2018. Environmental Assessment of Emerging Technologies: Recommendations for Prospective LCA. *Journal of Industrial Ecology* 22(6): 1286-1294.
- Balieu, R., F. Chen, and N. Kringos. 2019. Life cycle sustainability assessment of electrified road systems. *Road Materials and Pavement Design* 20(sup1): S19-S33.
- Bi, Z., R. De Kleine, and G. A. Keoleian. 2017. Integrated Life Cycle Assessment and Life Cycle Cost Model for Comparing Plug-in versus Wireless Charging for an Electric Bus System. *Journal of Industrial Ecology* 21(2): 344-355.
- Bi, Z., L. Song, R. De Kleine, C. C. Mi, and G. A. Keoleian. 2015. Plug-in vs. wireless charging: Life cycle energy and greenhouse gas emissions for an electric bus system. *Applied Energy* 146: 11-19.
- Çağatay Bayındır, K., M. A. Gözüküçük, and A. Teke. 2011. A comprehensive overview of hybrid electric vehicle: Powertrain configurations, powertrain control techniques and electronic control units. *Energy Conversion and Management* 52(2): 1305-1313.
- Cerdas, F., P. Egede, and C. Herrmann. 2018. LCA of Electromobility. In *Life Cycle Assessment - Theory and Practice*, edited by M. Hauschild, et al. eBook: Springer.
- Cetinkaya, E., I. Dincer, and G. F. Naterer. 2012. Life cycle assessment of various hydrogen production methods. *International Journal of Hydrogen Energy* 37(3): 2071-2080.
- Cooney, G., T. R. Hawkins, and J. Marriott. 2013. Life cycle assessment of diesel and electric public transportation buses. *Journal of Industrial Ecology* 17(5): 689-699.
- Corrigan, D. A. and A. Masias. 2011. Batteries for Electric and Hybrid Electric Vehicles. In *Linden's Handbook of Batteries*, edited by T. B. Reddy. New York: McGraw Hill.
- Cucurachi, S., C. van der Giesen, and J. Guinée. 2018. Ex-ante LCA of Emerging Technologies. *Procedia CIRP* 69: 463-468.
- Del Duce, A., M. Gauch, and H.-J. Althaus. 2014. Electric passenger car transport and passenger car life cycle inventories in ecoinvent version 3. *The International Journal of Life Cycle Assessment*.
- Del Duce, A., P. Egede, G. Öhlschläger, T. Dettmer, H.-J. Althaus, T. Büttler, and E. Szczechowicz. 2013. *eLCar - Guidelines for the LCA of electric vehicles*. Reprint to the European Union's Seventh Framework Programme.
- Dunn, J. B., L. Gaines, J. C. Kelly, C. James, and K. G. Gallagher. 2015. The significance of Li-ion batteries in electric vehicle life-cycle energy and emissions and recycling's role in its reduction. *Energy & Environmental Science* 8(1): 158-168.
- Egede, P., T. Dettmer, C. Herrmann, and S. Kara. 2015. Life Cycle Assessment of Electric Vehicles – A Framework to Consider Influencing Factors. *Procedia CIRP* 29: 233-238.
- Ellingsen, L. A.-W., C. R. Hung, and A. H. Strømman. 2017. Identifying key assumptions and differences in life cycle assessment studies of lithium-ion traction batteries with focus on greenhouse gas emissions. *Transportation Research Part D: Transport and Environment* 55: 82-90.
- Elliot, T., S. J. McLaren, and R. Sims. 2018. Potential environmental impacts of electric bicycles replacing other transport modes in Wellington, New Zealand. *Sustainable Production and Consumption* 16: 227-236.
- Emadi, A., L. Young Joo, and K. Rajashekara. 2008. Power Electronics and Motor Drives in Electric, Hybrid Electric, and Plug-In Hybrid Electric Vehicles. *IEEE Transactions on Industrial Electronics* 55(6): 2237-2245.
- Ercan, T. and O. Tatari. 2015. A hybrid life cycle assessment of public transportation buses with alternative fuel options. *International Journal of Life Cycle Assessment* 20(9): 1213-1231.
- Finnveden, G., M. Z. Hauschild, T. Ekvall, J. Guinée, R. Heijungs, S. Hellweg, A. Koehler, D. Pennington, and S. Suh. 2009. Recent developments in Life Cycle Assessment. *Journal of Environmental Management* 91(1): 1-21.
- Frischknecht, R. and K. Flury. 2011. Life cycle assessment of electric mobility: answers and challenges—Zurich, April 6, 2011. *The International Journal of Life Cycle Assessment* 16(7): 691-695.

- Fuc, P., P. Kurczewski, A. Lewandowska, E. Nowak, J. Selech, and A. Ziolkowski. 2016. An environmental life cycle assessment of forklift operation: a well-to-wheel analysis. *International Journal of Life Cycle Assessment* 21(10): 1438-1451.
- Gheewala, S. H., G. Berndes, and G. Jewitt. 2011. The bioenergy and water nexus. *Biofuels, Bioproducts and Biorefining* 5(4): 353-360.
- Hauschild, M. Z. and M. A. J. Huijbregts. 2015. Life Cycle Impact Assessment. In *LCA Compendium - The Complete World of Life Cycle Assessment*, edited by W. Klöpffer and M. A. Curran. Dordrecht: Springer.
- Hawkins, T. R., O. M. Gausen, and A. H. Strømman. 2012. Environmental impacts of hybrid and electric vehicles—a review. *The International Journal of Life Cycle Assessment* 17(8): 997-1014.
- Husain, I. 2011. *Electric and Hybrid Vehicles: Design Fundamentals*. Second ed: CRC Press, Taylor & Francis Group.
- IEA. 2016. *Global EV Outlook 2016 – Beyond one million electric cars*. Paris, France: International Energy Agency.
- ISO. 2006. *Environmental Management - Life Cycle Assessment - Principles and framework*. Geneva, Switzerland: International Organisation for Standardization.
- Jayaprakash, N., S. K. Das, and L. A. Archer. 2011. The rechargeable aluminum-ion battery. *Chemistry Communication* 47: 12610-12612.
- Lee, D. Y. and V. M. Thomas. 2017. Parametric modeling approach for economic and environmental life cycle assessment of medium-duty truck electrification. *Journal of Cleaner Production* 142: 3300-3321.
- Lee, D. Y., V. M. Thomas, and M. A. Brown. 2013. Electric urban delivery trucks: Energy use, greenhouse gas emissions, and cost-effectiveness. *Environmental Science and Technology* 47(14): 8022-8030.
- Liu, W., J. Sang, L. Chen, J. Tian, H. Zhang, and G. Olvera Palma. 2015. Life cycle assessment of lead-acid batteries used in electric bicycles in China. *Journal of Cleaner Production* 108: 1149-1156.
- Melin, H. E. 2019. Forskningsöversikt om återvinning och återbruk av litiumjonbatterier (Eng. Review of recycling and reuse of lithium ion batteries). <http://www.energimyndigheten.se/globalassets/forskning--innovation/overgripande/forskningsoversikt-om-atervinning-och-aterbruk-av-litiumjonbatterier-2019.pdf>: Swedish Energy Agency.
- Ness, B., E. Urbel-Piirsalu, S. Anderberg, and L. Olsson. 2007. Categorising tools for sustainability assessment. *Ecological Economics* 60(3): 498-508.
- Nordelöf, A. 2017. Using life cycle assessment to support the development of electrified road vehicles. Thesis, Graduate School of Energy and Environment, Division of Environmental Systems Analysis, Department of Technology Management and Economics, Chalmers University of Technology, Gothenburg, Sweden.
- Nordelöf, A. and A.-M. Tillman. 2018. A scalable life cycle inventory of an electrical automotive traction machine—Part II: manufacturing processes. *The International Journal of Life Cycle Assessment* 23(2): 295-313.
- Nordelöf, A., M. Alatalo, and M. Ljunggren Söderman. 2019a. A scalable life cycle inventory of an automotive power electronic inverter unit—Part I: design and composition. *The International Journal of Life Cycle Assessment* 24(1): 78-92.
- Nordelöf, A., M. Messagie, A.-M. Tillman, M. Ljunggren Söderman, and J. Van Mierlo. 2014. Environmental impacts of hybrid, plug-in hybrid, and battery electric vehicles—what can we learn from life cycle assessment? *The International Journal of Life Cycle Assessment* 19(11): 1866-1890.
- Nordelöf, A., S. Poulidikou, M. Chordia, F. Bitencourt de Oliveira, J. Tivander, and R. Arvidsson. 2019b. Methodological Approaches to End-Of-Life Modelling in Life Cycle Assessments of Lithium-Ion Batteries. *Batteries* 5(3): 51.
- Ponrouch, A., C. Frontera, F. Bardé, and M. R. Paalacín. 2015. Towards a calcium-based rechargeable battery. *Nature Materials* 15: 169-172.

- Scania. 2016. Scania tests fast wireless charging in urban traffic. <https://www.scania.com/group/en/scania-tests-fast-wireless-charging-in-urban-traffic/>. Accessed 19 August 2019.
- SmartRoad Gotland. 2019. The world's first wireless electric road charging an e-bus and an e-truck. <https://www.smartroadgotland.com/>. Accessed 19 August 2019.
- Sonderegger, T., J. Dewulf, P. Fantke, D. M. de Souza, S. Pfister, F. Stoessel, F. Verones, M. Vieira, B. Weidema, and S. Hellweg. 2017. Towards harmonizing natural resources as an area of protection in life cycle impact assessment. *The International Journal of Life Cycle Assessment* 22(12): 1912-1927.
- Song, Q., Z. Wang, Y. Wu, J. Li, D. Yu, H. Duan, and W. Yuan. 2018. Could urban electric public bus really reduce the GHG emissions: A case study in Macau? *Journal of Cleaner Production* 172: 2133-2142.
- Suh, S. and G. Huppes. 2005. Methods for Life Cycle Inventory of a product. *Journal of Cleaner Production* 13(7): 687-697.
- Tillman, A.-M. 2000. Significance of decision-making for LCA methodology. *Environmental Impact Assessment Review* 20(1): 113-123.
- Vandepaer, L., J. Cloutier, C. Bauer, and B. Amor. 2019. Integrating Batteries in the Future Swiss Electricity Supply System: A Consequential Environmental Assessment. *Journal of Industrial Ecology* 23(3): 709-725.
- Weidema, B. P., C. Bauer, R. Hirschler, C. Mutel, T. Nemecek, J. Reinhard, C. O. Vadenbo, and G. Wernet. 2013. The ecoinvent database: Overview and methodology, Data quality guideline for the ecoinvent database version 3. www.ecoinvent.org. Accessed 2014-2017.
- Wernet, G., C. Bauer, B. Steubing, J. Reinhard, E. Moreno-Ruiz, and B. Weidema. 2016. The ecoinvent database version 3 (part I): overview and methodology. *The International Journal of Life Cycle Assessment* 21(9): 1218-1230.
- Villares, M., A. Işıldar, C. van der Giesen, and J. Guinée. 2017. Does ex ante application enhance the usefulness of LCA? A case study on an emerging technology for metal recovery from e-waste. *The International Journal of Life Cycle Assessment* 22(10): 1618-1633.
- Xu, Y., F. E. Gbologah, D. Y. Lee, H. Liu, M. O. Rodgers, and R. L. Guensler. 2015. Assessment of alternative fuel and powertrain transit bus options using real-world operations data: Life-cycle fuel and emissions modeling. *Applied Energy* 154: 143-159.
- Yang, L., C. Hao, and Y. Chai. 2018. Life cycle assessment of commercial delivery trucks: Diesel, plug-in electric, and battery-swap electric. *Sustainability (Switzerland)* 10(12).
- Zhao, Y. and O. Tatari. 2017. Carbon and energy footprints of refuse collection trucks: A hybrid life cycle evaluation. *Sustainable Production and Consumption* 12: 180-192.
- Zhou, T., M. J. Roorda, H. L. MacLean, and J. Luk. 2017. Life cycle GHG emissions and lifetime costs of medium-duty diesel and battery electric trucks in Toronto, Canada. *Transportation Research Part D: Transport and Environment* 55: 91-98.
- Zubi, G., R. Dufo-López, M. Carvalho, and G. Pasaoglu. 2018. The lithium-ion battery: State of the art and future perspectives. *Renewable and Sustainable Energy Reviews* 89: 292-308.