



A wideband 3-dB directional coupler in GGW for use in V-Band communication systems

Downloaded from: <https://research.chalmers.se>, 2020-07-11 06:29 UTC

Citation for the original published paper (version of record):

Nasri, M., Zarifi, D., Uz Zaman, A. (2020)

A wideband 3-dB directional coupler in GGW for use in V-Band communication systems

IEEE Access, 8: 17819-17823

<http://dx.doi.org/10.1109/ACCESS.2020.2968609>

N.B. When citing this work, cite the original published paper.

©2020 IEEE. Personal use of this material is permitted.

However, permission to reprint/republish this material for advertising or promotional purposes or for creating new collective works for resale or redistribution to servers or lists, or to reuse any copyrighted component of this work in other works must be obtained from the IEEE.

A Wideband 3-dB Directional Coupler in GGW for Use in V-Band Communication Systems

MARZIEH NASRI¹, DAVOUD ZARIFI¹, AND ASHTAF UZ ZAMAN², (Member, IEEE)

¹Electrical and Computer Engineering Department, University of Kashan, Khashan 8731753153, Iran

²Department of Signals and Systems, Chalmers University of Technology, SE-412 96 Göteborg, Sweden

Corresponding author: Davoud Zarifi (zarifi@kashanu.ac.ir)

ABSTRACT In this article, a broadband 3-dB directional coupler is proposed using groove gap waveguide (GGW) structures. Gap waveguide technology has been introduced to overcome manufacturing and assembling challenges of different millimeter-wave components and devices. The presented coupler has wideband coupling flatness with low return loss in 60-GHz frequency band and can be easily adapted to other frequency ranges. Experimentally, a sample prototype of the proposed 3-dB coupler has been designed and fabricated. The measured return loss and isolation are better than 20 dB and the power-split unbalance within ± 0.5 dB is obtained over the frequency range from 57 to 74 GHz (26% BW). The proposed structure has the capability of easily integrating with other millimeter-wave components.

INDEX TERMS Gap waveguide technology, directional coupler, branch-guide.

I. INTRODUCTION

Directional couplers are widely used in different microwave components and networks. These components can be implemented based on different kinds of traditional planar technologies as microstrip lines [1], striplines [2] and substrate integrated waveguides (SIWs) [3]. In all of these substrate based structures, low power handling capacity, high substrate and ohmic losses and undesired radiations may be of concern especially for millimeter-wave frequencies.

In low loss waveguide directional couplers, by making holes in the common wall between two adjacent waveguides, energy is coupled through the holes from the main to the coupled guide. At the design frequency band, couplings to the waveguide cancel in one direction while add in the other direction. Examples are single, multi and continuous aperture coupling [4], [5]. In the branch-guide directional couplers, the coupling region consists of a number of series branch lines connecting the two waveguides [6]. Generally, these types of couplers are broadband with an appropriate coupling flatness and especially applicable for couplers with the 3- to 10-dB coupling values. In the last decades, some synthesis techniques based on equivalent circuit representations have been presented for design of branch-guide directional couplers [6]–[8]. In most of these methods, simplified models

are considered and it is not easy to accurately quantify the capacitance or inductance in waveguide junctions. This usually leads to considerable disagreement with measurement. In addition, a number of field theory based techniques have been studied in [9], [10], though they are suitable only for the conventional simple structures for which analytical expressions exist. For complex new structures such as gap waveguides, due to mathematical complexity, it is not possible to use analytical solutions in the synthesis procedure. The high design accuracy required can only be obtained by numerical and optimization techniques [10].

Gap waveguide technology is one of the new suitable guiding structures for millimeter-wave applications [11]. This technology offers low-cost and high-performance contactless H-plane waveguide split-block solution where joint between the adjacent metal plates is not an issue. In addition, GW guiding structures benefit from relatively low loss, broad frequency bandwidth, manufacturing flexibility, cost effectiveness and high power handling at millimeter-wave frequencies. As a result, during the past few years, this technology has been successfully applied to design and fabrication of various antenna arrays and millimeter-wave passive and active components [12]–[15].

More recently, broadband GGW based directional couplers with coupling values between 10 and 30 dB have been introduced for 60-GHz frequency band applications [16]. Design procedure for achieving 3-dB coupling value and broadband

The associate editor coordinating the review of this manuscript and approving it for publication was Haiwen Liu.

coupling flatness in this type of couplers requires using many coupling apertures that increases the structure length dramatically. In the other hand, to the authors' knowledge, V-band waveguide 3-dB couplers are rarely found in the literature. To overcome these issues, this paper presents a wideband GGW based 3-dB coupler for V-band applications. The design is performed in a waveguide branch-guide coupler by using five rectangular apertures in the common wall of two parallel GW guiding structures.

II. GGW STRUCTURE

The configuration of GGW is illustrated in Fig. 1. In this structure, perfect electric conductor and perfect magnetic conductor are employed to make desired frequency band-stop. The artificial magnetic surface can be realized by periodic metallic pins on bottom metal plate. By removing several rows of the periodic pins, a guiding wave mode can propagate in the structure. Consequently, good electrical contact between the metal plates is not needed in this guiding structure. The pin dimensions and groove width need to be designed correctly for appropriate stop bandwidth. Here, we consider $w = 3.7$ mm, $a = 0.5$ mm, $p = 1.5$ mm, $h = 1.35$ mm, and $g = 0.2$ mm to achieve a stop-band from 40 to 80 GHz [16].

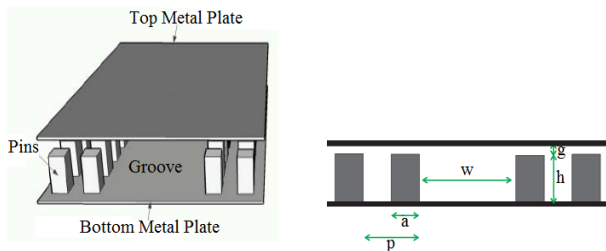

FIGURE 1. Configuration of groove gap waveguide structure.

III. COUPLER DESIGN AND SIMULATION RESULTS

The schematic of a conventional waveguide branch-guide coupler is illustrated in Fig. 2. Two parallel adjacent rectangular waveguides are coupled by N branch guides connected along the broad walls. Additional degrees of freedom are obtained by allowing the main wave guide sections between the branches to have different heights, thus different impedances. The frequency bandwidth can be improved by increasing the number of branches [7]. The detailed design and optimization procedure of conventional waveguide branch-guide couplers has been discussed in [10].

The proposed structure for GGW coupler and detailed description of its 3-D model are depicted in Fig. 3. Ports #1, #2, #3, and #4 are the input, through, coupled, and isolated ports, respectively. As shown in Fig. 3, the coupler is constructed of two groove gap waveguides coupled along the broad walls by 5-branches of different widths. It is important to note that optimization procedure depends heavily on the initial values. The detailed design procedure of waveguide

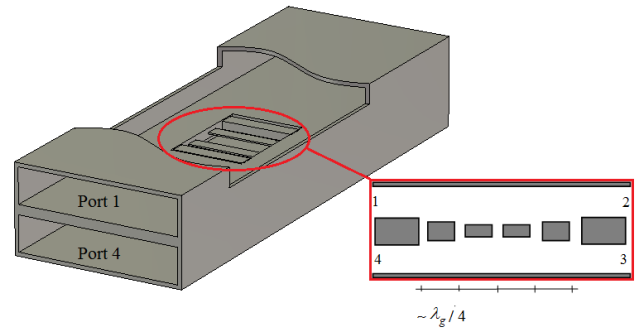

FIGURE 2. Schematic of a waveguide branch-guide coupler.

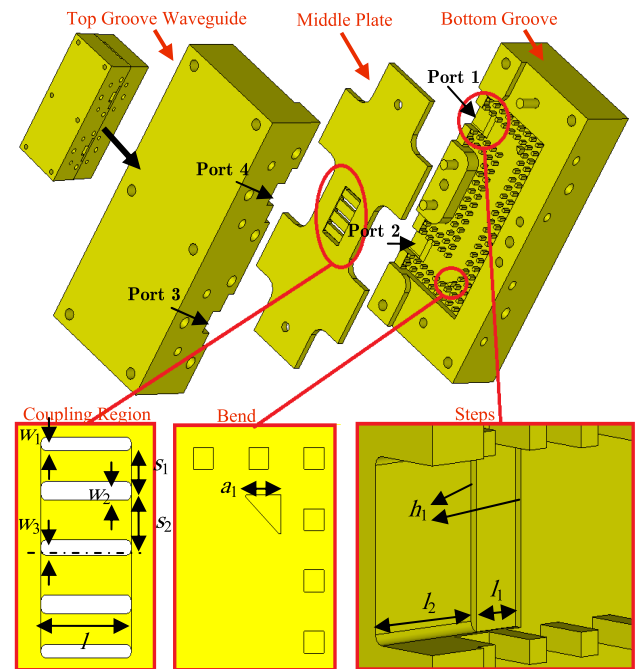

FIGURE 3. Exploded perspective view of the proposed 3-dB directional coupler. The optimized values in mm are $w_1 = 0.57$, $w_2 = 0.70$, $w_3 = 0.54$, $l = 3.70$, $s_1 = 1.77$, $s_2 = 2.10$, $a_1 = 0.88$, $h_1 = 0.17$, $l_1 = 1.14$, $l_2 = 2.77$, thickness of coupling holes = 0.9 and thickness of middle metal plate = 1.3.

branch-guide coupler discussed in [6] is used as the starting guideline for the design based on gap waveguide structure. Here, in the design and optimization procedure, the lengths of branches and spacing between them are initially considered quarter-guide wavelength at 60 GHz. According to the design specifications, the minimization of an error function defined as

$$Error = \left(\frac{1}{N} \sum_{n=1}^N \left(|S_{11}(f_n)|^2 + |3(dB) - S_{31}(f_n)|^2 \right) \right)^{0.5} \quad (1)$$

determines the optimized values for design parameters. Note that S_{11} and S_{31} are input reflection and coupling coefficients of the coupler over the desired frequency bandwidth from 50 to 75 GHz. The designed structure is simulated by using the full-wave electromagnetic solver CST Microwave Studio.

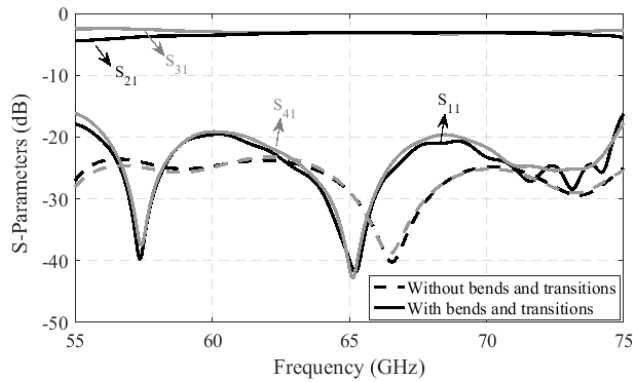

FIGURE 4. Simulation results of proposed 3-dB directional coupler.

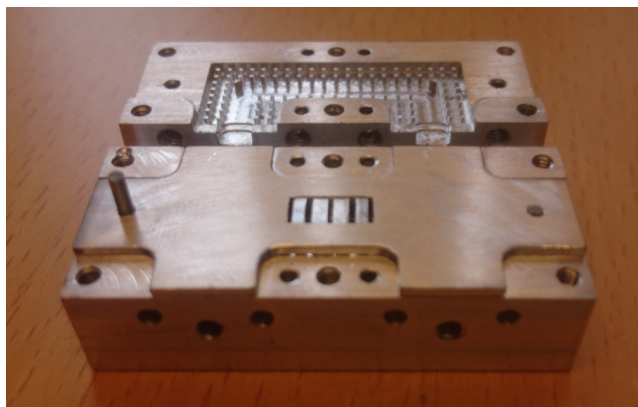

FIGURE 5. Photograph of fabricated directional coupler prototype.

For measurement purpose, transitions of GGW to WR-15 (standard V-band rectangular waveguide) should be designed. The proposed transition is composed of a H-Plane corner and two steps. For changing the direction of guides through 90° angle, corners are used. By tuning the position of chamfered pin in the corner, the direction of electromagnetic wave propagation can effectively change with negligible reflection throughout the frequency range the coupler are to be used. Because of different height of WR-15 and GGW, two quarter-wavelength steps are inserted in the bottom plate in order to decrease reflection. Finally, after connecting these parts to the coupler and for achieving low input return loss, the parameters of the steps and corners are optimized. Fig. 4 illustrates the frequency response of proposed coupler with and without transitions. Observe that the return loss and isolation are better than 20 dB and the coupling value is 3 ± 0.5 dB over frequency range of 56 GHz to 75 GHz.

It is possible to scale the introduced 3-dB directional coupler to other operating frequencies. Briefly, the design process of coupler can be summarized as follows:

- The design frequency is determined as center point of the desired operating bandwidth.
- The number of branches is determined with considering space constraints and desired electrical performance.

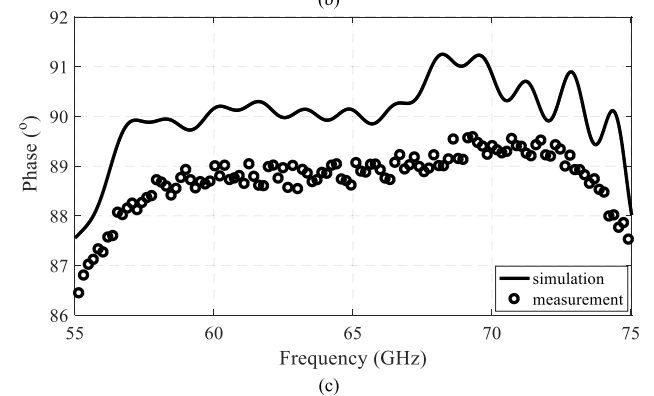
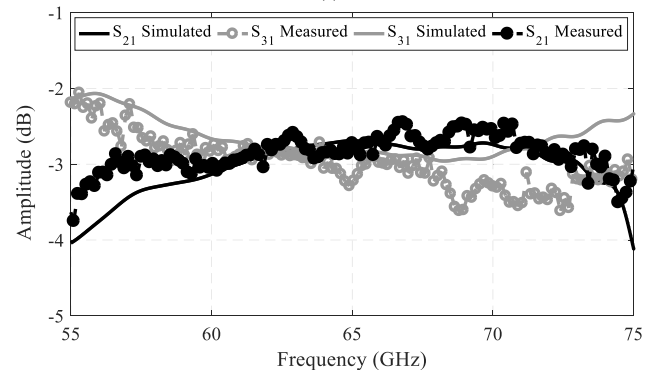
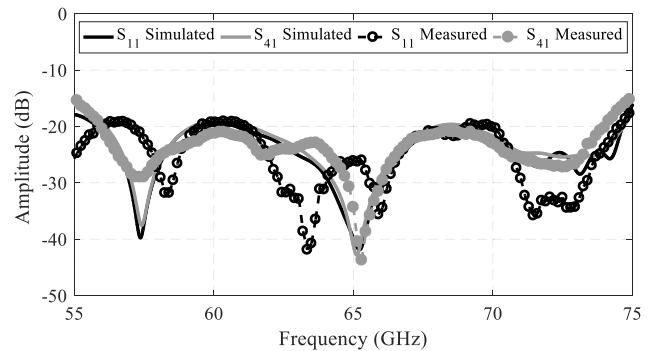

FIGURE 6. (a) Measured and computed return loss ($|S_{11}|$) and isolation ($|S_{41}|$), (b) measured and computed $|S_{21}|$ and $|S_{31}|$ values, and (c) measured and computed relative phases of S_{21} and S_{31} of the proposed geometry.

- The lengths of branches and spacing between them are assumed initially as $\lambda_g/4$.

To satisfy the desired specifications including input matching requirements and balanced outputs with coupling flatness, an optimization procedure should be employed.

IV. FABRICATION AND MEASUREMENT

To illustrate the operation of proposed structure, a sample prototype is constructed by standard computer numerical control milling techniques in aluminum material. The fabricated 3-dB directional coupler is shown in Figure 5 before performing the assembly to illustrate the details of its different layers. The overall size of assembled coupler is $45 \times 24 \times 19$ mm³.

TABLE 1. Comparison between reported and present proposed couplers.

Type	Freq. (GHz)	B.W (%)	Coupling (dB)	Isolation (dB)
Rectangular Waveguide [5]	6.6 - 10	41	3 ± 0.6	> 26
Ridge Gap Waveguide [15]	13.8 - 15.8	14	3 ± 0.5	> 15
Rectangular Waveguide [8]	31 - 36	15	3 ± 1	> 36
Rectangular Coaxial Lines [17]	57 - 63	10	3.6 ± 0.5	> 18
IPD-Based Branch Line [18]	57 - 64	11.6	3 ± 0.6	> 17
E-plane Branch Line Bridge [19]	85 - 96	12	3.3 ± 0.6	> 20
This Work	57 - 74	25	3 ± 0.5	> 20

The scattering parameters of the fabricated coupler are measured using a vector network analyzer through WR-15 waveguide flanges. Fig. 6 shows the simulated and measured frequency response of the coupler which agree with each other. The discrepancies between the results may be attributed to extra loss due to metal conductivity degradation owing to surface roughness, the fabrication inaccuracies in the computer numerical control (CNC) milling and assembling tolerances. The experimental results show that the $|S_{11}| < -20$ dB bandwidth is 27% covering 56-74 GHz, and the isolation is better than 20 dB. Also, the power-split unbalance is within ± 0.5 dB and phase difference of output ports is $89 \pm 0.5^\circ$ from 57 to 74 GHz. Since the GW structures have more details with respect to the conventional rectangular waveguides, usually some frequency shifts is seen in simulation and measurement results due to the fabrication inaccuracies.

In Table 1, specifications and performances of different kinds of reported couplers are compared with the present work. To the best knowledge of the authors, no such V-band waveguide 3-dB directional coupler with acceptable coupling flatness has ever been proposed in the literature before.

V. CONCLUSION

The design of a wideband 3-dB directional coupler based on GGW for 60 GHz frequency band is studied numerically and experimentally. With the presented geometry, no physical contact is needed between the different layers of the H-plane guiding structures. Over the frequency band of 57-74 GHz, the 3-dB coupler has a return loss of better than 20 dB. With transitions designed in the structure, the coupler can directly be connected to standard rectangular waveguide. Experiments confirm the design and basic operation of fabricated 3-dB coupler. The results serve as a reference for designing other wideband millimeter-wave passive components.

REFERENCES

[1] H.-L. Ting, S.-K. Hsu, and T.-L. Wu, "A novel and compact eight-port forward-wave directional coupler with arbitrary coupling level design using four-mode control technology," *IEEE Trans. Microw. Theory Techn.*, vol. 65, no. 2, pp. 467–475, Feb. 2017.

[2] W. Fathelbab, "The synthesis of a class of branch-line directional couplers," *IEEE Trans. Microw. Theory Techn.*, vol. 56, no. 8, pp. 1985–1994, Aug. 2008.

[3] A. Doghri, T. Djeraji, A. Ghiotto, and K. Wu, "Substrate integrated waveguide directional couplers for compact three-dimensional integrated circuits," *IEEE Trans. Microw. Theory Techn.*, vol. 63, no. 1, pp. 209–221, Jan. 2015.

[4] W. Shelton, "Compact multi-hole waveguide directional couplers," *Microw. J.*, vol. 4, pp. 89–92, Jul. 1961.

[5] Y. Zhang, Q. Wang, and H. Xin, "A compact 3 dB E-plane waveguide directional coupler with full bandwidth," *IEEE Microw. Wireless Compon. Lett.*, vol. 24, no. 4, pp. 227–229, Apr. 2014.

[6] R. Levy and L. Lind, "Synthesis of symmetrical branch-guide directional couplers," *IEEE Trans. Microw. Theory Techn.*, vol. MTT-16, no. 2, pp. 80–89, Feb. 1968.

[7] L. Young, "Synchronous branch guide directional couplers for low and high power applications," *IRE Trans. Microw. Theory Techn.*, vol. 10, no. 6, pp. 459–475, Nov. 1962.

[8] R. Levy, "Analysis of practical branch-guide directional couplers (correspondence)," *IEEE Trans. Microw. Theory Techn.*, vol. MTT-17, no. 5, pp. 289–290, May 1969.

[9] F. Arndt, B. Koch, H.-J. Orlok, and N. Schroder, "Field theory design of rectangular waveguide broad-wall metal-insert slot couplers for millimeter-wave applications (correction)," *IEEE Trans. Microw. Theory Techn.*, vol. MTT-34, no. 9, p. 985, Sep. 1986.

[10] F. Alessandri, G. Bartolucci, and R. Sorrentino, "Admittance matrix formulation of waveguide discontinuity problems: Computer-aided design of branch guide directional couplers," *IEEE Trans. Microw. Theory Techn.*, vol. MTT-36, no. 2, pp. 394–403, Feb. 1988.

[11] P.-S. Kildal, E. Alfonso, A. Valero-Nogueira, and E. Rajo-Iglesias, "Local metamaterial-based waveguides in gaps between parallel metal plates," *IEEE Antennas Wireless Propag. Lett.*, vol. 8, pp. 84–87, 2009.

[12] D. Zarifi, A. Farahbakhsh, and A. U. Zaman, "A gap waveguide-fed wideband patch antenna array for 60-GHz applications," *IEEE Trans. Antennas Propag.*, vol. 65, no. 9, pp. 4875–4879, Sep. 2017.

[13] B. Ahmadi and A. Banai, "Direct coupled resonator filters realized by gap waveguide technology," *IEEE Trans. Microw. Theory Techn.*, vol. 63, no. 10, pp. 3445–3452, Oct. 2015.

[14] D. Sun and J. Xu, "A novel iris waveguide bandpass filter using air gapped waveguide technology," *IEEE Microw. Wireless Compon. Lett.*, vol. 26, no. 7, pp. 475–477, Jul. 2016.

[15] S. I. Shams and A. A. Kishk, "Design of 3-dB hybrid coupler based on RGW technology," *IEEE Trans. Microw. Theory Techn.*, vol. 65, no. 10, pp. 3849–3855, Oct. 2017.

[16] D. Zarifi, A. Farahbakhsh, and A. U. Zaman, "Design and fabrication of wideband millimeter-wave directional couplers with different coupling factors based on gap waveguide technology," *IEEE Access*, vol. 7, pp. 88822–88829, 2019.

[17] J. Reid and R. Webster, "A 60 GHz branch line coupler fabricated using integrated rectangular coaxial lines," in *IEEE MTT-S Int. Microw. Symp. Dig.*, Nov. 2004, pp. 441–444.

[18] I. Haroun, C. Plett, Y.-C. Hsu, and D.-C. Chang, "Compact 60-GHz IPD-based branch-line coupler for system-on-package V-band radios," *IEEE Trans. Compon., Packag., Manuf. Technol.*, vol. 2, no. 7, pp. 1070–1074, Jul. 2012.

[19] P. Zheng, H.-J. Sun, M.-J. Luo, Z.-L. Wen, and H. Deng, "W-band waveguide 3 dB directional coupler based on E-plane branch line bridge," in *Proc. Asia-Pacific Microw. Conf. (APMC)*, Nov. 2013, pp. 279–281.



MARZIEH NASRI was born in Kashan, Iran, in 1994. She received the B.Sc. degree in electrical engineering from the University of Kashan, Kashan, in 2016, where she is currently pursuing the M.Sc. degree in electrical engineering. Her current research interests include gap waveguide technology, electromagnetic wave propagation, and metamaterials.



DAVOUD ZARIFI was born in Kashan, Iran, in 1987. He received the B.S. degree from the University of Kashan, Kashan, in 2009, the M.S. degree from the Iran University of Science and Technology (IUST), Tehran, Iran, in 2011, and the Ph.D. degree from IUST, in 2015, all in electrical engineering. He is currently an Assistant Professor with the School of Electrical and Computer Engineering, University of Kashan. His research interests are electromagnetic waves in complex

media, inverse problems in electromagnetic, applications of metamaterials, microwave passive components, slot array antennas, and gap waveguide technology.



ASHTAF UZ ZAMAN (Member, IEEE) was born in Chittagong, Bangladesh. He received the B.Sc. degree in electrical and electronics engineering from the Chittagong University of Engineering and Technology, Chittagong, and the M.Sc. and Ph.D. degrees from the Chalmers University of Technology, Gothenburg, Sweden, in 2007 and 2013, respectively. He is currently an Associate Professor with the Communication and Antenna Systems Division, Chalmers University of Technology. His

current research interests include millimeter-wave planar antennas in general, gap waveguide technology, frequency-selective surfaces, microwave passive components, and packaging techniques, and integration of MMICs with the antennas.

...