

**The effects of growth factors and antiproliferative agents  
on ocular fibroblasts and wound healing after  
glaucoma filtration surgery**

Peng Tee Khaw  
Institute of Ophthalmology and  
Moorfields Eye Hospital  
London

Thesis submitted for the degree of  
Doctor of Philosophy  
University of London  
June 1994

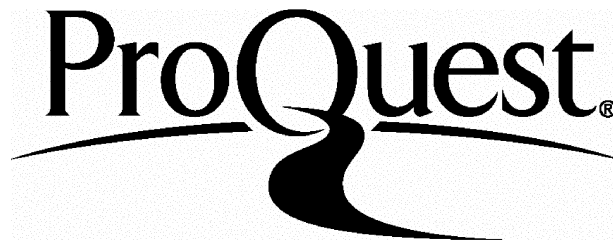
ProQuest Number: 10105196

All rights reserved

INFORMATION TO ALL USERS

The quality of this reproduction is dependent upon the quality of the copy submitted.

In the unlikely event that the author did not send a complete manuscript and there are missing pages, these will be noted. Also, if material had to be removed, a note will indicate the deletion.



ProQuest 10105196

Published by ProQuest LLC(2016). Copyright of the Dissertation is held by the Author.

All rights reserved.

This work is protected against unauthorized copying under Title 17, United States Code.  
Microform Edition © ProQuest LLC.

ProQuest LLC  
789 East Eisenhower Parkway  
P.O. Box 1346  
Ann Arbor, MI 48106-1346

To my parents, wife and daughter who have sacrificed  
so much to support my research.

## Abstract

Glaucoma (visual damage associated with raised intraocular pressure) is a major cause of worldwide blindness. The most effective treatment for glaucoma is filtration surgery, but the major cause of failure and suboptimal lowering of the intraocular pressure is scarring at the site of the surgery. In this thesis, I investigated the role of stimulatory molecules found in aqueous humour, and the effects of antiproliferative agents on ocular fibroblasts.

Fibronectin levels were found to be significantly raised in the aqueous of patients with glaucoma, but the chemoattractant activity of the aqueous was not. All growth factors tested stimulated proliferation, migration and collagen production, but transforming growth factor- $\beta$ 1 stimulated proliferation, migration and proline uptake at much lower concentrations than the other growth factors (epidermal, basic fibroblast and insulin-like growth factor-1). Following treatments with antiproliferative agents ocular fibroblasts could be growth arrested for periods much longer than previously thought, suggesting that single short treatments with these agents would inhibit fibroblast proliferation in the long term. The animal model results confirmed the *in vitro* findings with 5 minute applications of antiproliferative agents. Long term titratable effects on wound healing were shown in an experimental model of wound healing after glaucoma filtration surgery. The effects were focal and confined to the treated areas. Cells growth arrested by treatment could still be stimulated to increase RNA levels after stimulation with TGF- $\beta$ 1.

The experiments in this thesis have shown that growth factors present in the aqueous can have profound effects on the proliferation, migration and collagen production of ocular fibroblasts. In addition, the studies have led to a new understanding of the long term effects of short exposures to antiproliferative agents *in vitro* and *in vivo*, particularly that long term growth arrest can be induced and this effect can be localised, and can be varied to some degree. Finally, fibroblasts can still respond to growth factors despite being growth arrested.

## Publications arising during the course of this Thesis

- 1) 5-Fluorouracil and beyond (Editorial)  
P T Khaw I Grierson R A Hitchings N S C Rice  
**British Journal of Ophthalmology** 1991; 75: 577-588
- 2) The effects of beta-radiation on proliferating human Tenon's capsule fibroblasts  
P T Khaw S Ward I Grierson N S C Rice  
**British Journal of Ophthalmology** 1991; 75: 580-583
- 3) Experimental models of wound healing after glaucoma filtration surgery  
P T Khaw I Grierson M Miller J Joseph R A Hitchings  
In "**Applied pharmacology of glaucoma**" Drance SM Van Buskirk EM Neufeld EH,  
eds. Baltimore MD USA  
Williams and Wilkins. 1992
- 4) Chemoattractant qualities and fibronectin levels in patients with proliferative vitreoretinopathy  
N Wilson-Holt P T Khaw F Savage I Grierson  
**British Journal of Ophthalmology** 1992; 76: 159-162
- 5) The migratory response of corneal epithelium, fibroblasts and endothelium to growth factors  
M B Grant P T Khaw G S Schultz J Adams R Shimizu  
**Investigative Ophthalmology and Visual Science** 1992; 33: 3292-3301
- 6) Human corneal epithelium: autocrine production of TGF- $\alpha$  RNA and protein  
P T Khaw G S Schultz S L D MacKay N Chegini J Adams R Shimizu  
**Investigative Ophthalmology and Visual Science** 1992; 33: 3302-3306
- 7) Growth factors and ocular wound healing  
G S Schultz N Chegini M Grant P Khaw S L D MacKay  
**Acta Ophthalmologica** 1992; 70: 60-66.
- 8) Long term effects of sodium butyrate and 5-fluorouracil on ocular fibroblast proliferation  
P T Khaw S Ward A Porter I Grierson N S C Rice  
**Investigative Ophthalmology and Visual Science** 1992; 33: 2043-2052
- 9) Five minute exposures to 5-fluorouracil, mitomycin-c and 5-fluorouridine have long term effects on human Tenon's capsule fibroblasts  
P T Khaw M B Sherwood G S Schultz S L D MacKay M Rossi  
**Archives of Ophthalmology** 1992; 110: 1150-1154

- 10) Tissue effects of intraoperative vs post operative treatments with antiproliferative agents  
P T Khaw J W Doyle M B Sherwood M F Smith I Grierson S McGorray G S Schultz  
**International Ophthalmology** 1992; 16: 381-385
- 11) Short exposures to mitomycin-c and 5-fluorouracil prolong survival of rabbit filtration surgery  
P T Khaw J W Doyle M B Sherwood M F Smith S McGorray  
**Ophthalmology** 1993; 100: 367-372
- 12) Long term effects on conjunctival and sclera tissues after single dose intraoperative treatments with mitomycin-C or 5-fluorouracil  
P T Khaw J W Doyle M B Sherwood M F Smith S McGorray  
**Archives of Ophthalmology** 1993; 111: 263-267
- 13) Intra operative 5-fluorouracil and filtration surgery in the rabbit  
J W Doyle M B Sherwood P T Khaw S McGorray M F Smith  
**Investigative Ophthalmology and Visual Science** 1993; 34: 3313-3319
- 14) Growth factors and corneal wound healing  
G S Schultz P T Khaw N Chegini S MacCawley N Kerr  
**Eye** 1994; 8: 184-187
- 15) Activation and suppression of fibroblast function  
P T Khaw N L Occeleston I Grierson M B Sherwood G Larkin G Schultz  
**Eye** 1994; 8: 188-195
- 16) The effects of epidermal growth factor, basic fibroblast growth factor, transforming growth factor- $\beta$ 1 and insulin-like growth factor on fibroblast proliferation, migration and collagen production.  
P T Khaw N L Occeleston I Grierson G Schultz M B Grant  
**Investigative Ophthalmology and Visual Science (Suppl)** 1994; 35: 1898 (and submitted)

All the experiments in this thesis were carried out personally. The experiments were also conceived and designed by myself, after discussion and guidance from my supervisors.

<b>Table of contents</b>	<b>Page</b>
Title	1
Dedication	2
Abstract	3
List of Publications	4
Table of Contents	6
List of Figures	11
List of Abbreviations	16
Acknowledgements	17
<b>Chapter 1. Introduction</b>	<b>18</b>
1.1 The glaucomas and current treatments	18
1.11 The glaucomas	18
1.12 Maintenance of normal intraocular pressure	18
1.13 Reduction of intraocular pressure	19
1.14 Surgical reduction of intraocular pressure	19
1.2 Healing after glaucoma filtration surgery	23
1.21 Summary of events after filtration surgery	23
1.22 Healing after filtration surgery in man	27
1.23 The role of blood and the clotting system	28
1.24 The role of aqueous humour	31
1.25 Stimulatory factors found in aqueous humour	32
1.26 The role of inflammation and inflammatory cells	43
1.27 The role of the fibroblast:	46
Proliferation	46
Migration	49
Extracellular matrix synthesis and modelling	50
1.3 Modulation of healing after glaucoma filtering surgery	52
1.31 Anti-inflammatory agents	52
1.32 Thrombolytic agents	56
1.33 Anti-proliferative agents	59

1.34	Anti-contractile agents	66
1.35	Anti-collagen cross-linking agents	67
1.4	Justification and aims	68
<b>Chapter 2.</b>	<b>Materials and Methods</b>	<b>69</b>
2.1	Cell culture techniques	69
2.11	Primary culture of human Tenon's capsule fibroblasts	69
2.12	Maintenance of cell cultures	69
2.12	Aqueous collection	70
2.2	Fibronectin assay	70
2.3	Migration assays	72
2.31	Migration assay (modified Boyden chamber)	72
2.32	Modifications for growth factor migration assay	75
2.33	Addition of fibronectin antibody	76
2.4	Collagen production ( <sup>3</sup> H proline uptake assay)	76
2.5	Assays of cell proliferation and viability	77
2.51	Manual counting	77
2.52	Coulter counting	79
2.53	BrDu Uptake	80
2.54	Thymidine uptake	81
2.54	Trypan blue uptake	82
2.6	Pharmacokinetics of drug in the eye	83
2.7	Experimental model of filtration ("fistulising") surgery	84
2.71	Operative technique and study design	84
2.72	Assessment of intraocular pressure and bleb grading	86
2.73	Histology	87



2.8	Fibroblast tissue outgrowth assay	88
2.81	Tissue Biopsy technique	88
2.82	Explant outgrowth culture and quantification	88
2.9	Fibroblast RNA levels after growth factor treatment	90
2.91	Cell treatment with TGF- $\beta$	90
2.92	RNA extraction and quantification	90
2.93	P <sup>32</sup> DNA Probe preparation	91
2.94	Preparation of RNA, gel electrophoresis and blotting	92
2.95	Northern blot prehybridisation and hybridisation	93
2.96	Washing and autoradiography	93
2.97	Quantitation of hybridised RNA	94
<b>Chapter 3. Results</b>		<b>95</b>
3.1	Fibroblast cell culture	95
3.2	Migration of ocular fibroblasts to aqueous from patients with cataract, primary and secondary glaucomas.	95
3.21	Migration to aqueous	95
3.22	Fibronectin levels in aqueous	97
3.23	Correlation of migration and fibronectin levels	97
3.24	Effect of fibronectin antibody on migration to aqueous	97
3.3	Effects of transforming growth factor- $\beta$ 1, epidermal growth factor and basic fibroblast growth factor on <sup>3</sup> H thymidine uptake, migration and <sup>3</sup> H proline uptake of ocular fibroblasts.	103
3.31	<sup>3</sup> H Thymidine uptake	103
3.32	Migration	106
3.33	<sup>3</sup> H Proline uptake	106
3.4	Effects of antiproliferative agents on ocular fibroblasts	111
3.41	1-14 day exposure to sodium butyrate and 5-fluorouracil	111
3.42	Single exposures to beta-irradiation	120
3.43	Single exposures to 5-fluorouracil, 5-fluorouridine and mitomycin-c	124

3.5	Pharmacokinetics of subconjunctival <sup>3</sup> H sodium butyrate	129
3.6	Effects of antiproliferative agents on experimental filtering surgery	129
3.61	Intraocular pressure	135
3.62	Drainage bleb	139
3.63	Histology	139
3.64	Complications	141
3.7	Long term effects of short single dose antiproliferatives on local and distant tissue fibroblasts	145
3.71	Subconjunctival tissue outgrowths	145
3.72	Scleral tissue outgrowths	148
3.73	Corneal tissue outgrowths	151
3.8	Effects of transforming growth factor-β1 on RNA levels of collagen, lysyl oxidase, and transforming growth factor-β1 and effects of growth arresting drug treatment	151
<b>Chapter 4. Discussion</b>		<b>155</b>
4.1	The role of aqueous and stimulatory factors	155
4.11	Role of aqueous in the healing process	155
4.12	Aqueous from eyes with glaucoma and cataract	155
4.13	Role of fibronectin component	156
4.2	Stimulatory effects of growth factors found in aqueous humour	158
4.21	Epidermal growth factor	158
4.22	Basic fibroblast growth factor	161
4.23	Transforming Growth Factor-β	163
4.24	Summary of effects of growth factors	165
4.25	Significance of growth factor levels <i>in vitro</i> and <i>in vivo</i>	165
4.26	Interaction of growth factors	170

4.3	Effects of antiproliferative agents on ocular fibroblasts <i>in vitro</i>	171
4.31	Growth arrest after exposures to antiproliferative agents	172
4.32	Previous data on growth arrest	172
4.33	Long term effects after very short term exposures to antiproliferative agents	174
4.34	Mechanism of growth arrest	174
4.35	<i>In vitro</i> and <i>in vivo</i> effects of antiproliferative agents	177
4.4	Effects of short single applications of antiproliferative agents <i>in vivo</i>	177
4.41	Duration of effect	177
4.42	Localisation of effect	179
4.43	Relevance to different healing profiles: a new model	180
4.5	Effects of transforming growth factor- $\beta$ 1 on RNA levels of collagen, lysyl oxidase, and transforming growth factor- $\beta$ 1 and effects of growth arresting drug treatment.	181
4.6	Conclusions	186
	References	187
	Appendix (equipment suppliers)	219

## List of Figures

<b>Page</b>	<b>Figure No</b>	<b>Description</b>
20	Fig 1	Diagram of fornix based glaucoma filtration surgery (anterior view).
21	Fig 2	Diagram of fornix based glaucoma filtration surgery (cross sectional view).
22	Fig 3	Photographs of successful and failed glaucoma filtration surgery.
24	Fig 4	Risk factors for failure of glaucoma filtration surgery due to scarring
25	Fig 5	Sequence of events in wound healing
33	Fig 6	Stimulatory biological molecules detected in intraocular fluids
37	Fig 7	Mechanism of TGF- $\beta$ enhancement of the extracellular matrix
44	Fig 8	Arachidonic acid metabolism and synthesis pathways for prostaglandins and leukotrienes
47	Fig 9	Competence and progression factors required for cellular proliferation
53	Fig 10	Sequence of events in wound healing and potential areas of modification after glaucoma filtering surgery
55	Fig 11	Arachidonic acid metabolism and points of inhibition
57	Fig 12	Extrinsic, intrinsic, and exogenous activation of plasmin.
60	Fig 13	Cell cycle and the effects of antineoplastic agents
61	Fig 14	Biochemical mechanism of action of the fluoropyrimidines
63	Fig 15	Table of different groups of antiproliferative agents
73	Fig 16	Modified Boyden migration chamber
85	Fig 17	Photographs of technique used to deliver single applications of antiproliferative agents in an experimental model of fistulising surgery.
89	Fig 18	Diagram of sites of tissue samples taken for explant outgrowth experiment.
96	Fig 19	Tenon's capsule fibroblasts in culture
98	Fig 20	Graph of fibroblast migration to aqueous humour from patients with cataracts (controls) and patients with glaucoma.
99	Fig 21	Chequerboard analysis of aqueous humour from patients with cataract (controls) and glaucoma.
100	Fig 22	Enzyme linked immunoassay standard curve for fibronectin with curves from aqueous specimens.

- 101 Fig 23 Graph of fibronectin levels in aqueous humour from patients with cataract and glaucoma.
- 102 Fig 24 Graph of number of fibroblasts migrated versus fibronectin levels.
- 104 Fig 25 Graph of fibroblast migration to human aqueous humour and fibronectin before and after addition of fibronectin antibody.
- 105 Fig 26 Graphs of thymidine uptake in fibroblasts after exposure to EGF, bFGF and TGF- $\beta$ 1.
- 107 Fig 27 Graphs of fibroblast migration after exposure to different concentrations of EGF, bFGF and TGF- $\beta$ 1.
- 108 Fig 28 Chequerboard analysis of fibroblast migration to EGF, bFGF and TGF- $\beta$ 1.
- 109 Fig 29 Graphs of fibroblast  $^3\text{H}$  Proline uptake after exposure to different concentrations of EGF, bFGF and TGF- $\beta$ 1.
- 110 Fig 30 Table summarising the effects of EGF, bFGF and TGF- $\beta$ 1 on human Tenon's fibroblast proliferation, migration and collagen production.
- 112 Fig 31 Fibroblast cell counts for 30 days after treatment with different concentrations of 5-fluorouracil over different treatment periods.
- 113 Fig 32 Fibroblast cell counts for 30 days after treatment with different concentrations of sodium butyrate over different treatment periods.
- 115 Fig 33 Table of calculated  $\text{ID}_{50}$  values for 5-Fluorouracil and sodium butyrate treated fibroblasts.
- 116 Fig 34 Graph of percentage of BrDU positive fibroblasts over 30 days after treatment with different concentrations of 5-fluorouracil over different treatment periods.
- 117 Fig 35 Graph of percentage of BrDU positive fibroblasts over 30 days after treatment with different concentrations of sodium butyrate over different treatment periods.
- 118 Fig 36 Photographs of untreated and treated fibroblasts after incubation with BrDU and immunostaining for cellular BrDU incorporation.
- 119 Fig 37 Photographs of fibroblasts treated with 5-fluorouracil and sodium butyrate for 3 days and then washed and stimulated with serum up to 24 days without treatment. Incubated with BrDU and immunostained for cellular BrDU incorporation.
- 121 Fig 38 Graph of percentage of Trypan blue positive fibroblasts over 30 days after treatment with different concentrations of 5-fluorouracil over different treatment periods.

- 122 Fig 39 Graph of percentage of trypan blue positive fibroblasts over 30 days after treatment with different concentrations of sodium butyrate over different treatment periods.
- 123 Fig 40 Graph of fibroblast cell counts over 14 days after treatment with different doses of  $\beta$ -radiation
- 125 Fig 41 Graphs of a)  $^3\text{H}$ -thymidine uptake and b) percentage trypan blue positive fibroblasts after treatment with different doses of  $\beta$ -radiation
- 127 Fig 42 Graph of fibroblast counts over 36 days after treatment with different concentrations of 5-fluorouracil, 5-fluorouridine and mitomycin-c for 5 minutes.
- 128 Fig 43 Table of  $\text{ID}_{50}$  concentrations at different time points over 36 days after 5 minute treatments with 5-fluorouracil, 5-fluorouridine and mitomycin-c for 5 minutes.
- 130 Fig 44 Photographs of fibroblasts 12 days after a five minute treatment with different concentrations of 5-fluorouracil, 5-fluorouridine and mitomycin-c for 5 minutes.
- 131 Fig 45 Photographs of fibroblasts 36 days after a five minute treatment with different concentrations of 5-fluorouracil, 5-fluorouridine and mitomycin-c for 5 minutes.
- 132 Fig 46 Graphs of  $^3\text{H}$  sodium butyrate pharmacokinetics in aqueous and cornea after subconjunctival injection.
- 133 Fig 47 Graphs of  $^3\text{H}$  sodium butyrate pharmacokinetics in conjunctiva and sclera after subconjunctival injection.
- 134 Fig 48 Concentrations of  $^3\text{H}$  butyrate in the eye after subconjunctival injection.
- 136 Fig 49 Photographs of rabbit eyes 5 days following "fistulising" surgery with single peroperative treatments with either distilled water or 5-fluorouracil.
- 137 Fig 50 Photographs of rabbit eyes 30 days after "fistulising" surgery combined with single peroperative treatments with either mitomycin-c or distilled water.
- 138 Fig 51 Graphs of 1) intraocular pressure in different treatment groups over 30 days following "fistulising" surgery. 2) Kaplan-Meier survival curves for intraocular pressure (failure = return of IOP to baseline).

- 140 Fig 52 Graphs of 1) mean bleb grade in different treatment groups over 30 days following "fistulising" surgery. 2) Kaplan-Meier survival curves for blebs (failure = flat bleb).
- 142 Fig 53 Histology of rabbit eyes 5 days after fistulising surgery and peroperative treatment with distilled water or 5-fluorouracil.
- 143 Fig 54 Histology of rabbit eyes after fistulising surgery and peroperative treatment with mitomycin-c 0.4 mg/ml (5 days previously) or 5-fluorouracil 50 mg/ml (10 days previously).
- 144 Fig 55 Histology of rabbit eyes 30 days after fistulising surgery and peroperative treatment with distilled water or mitomycin-c 0.4 mg/ml.
- 146 Fig 56 Graphs of fibroblast outgrowths from conjunctival biopsies taken one hour, 5 days and 30 days after surgery with intraoperative water (control), 5-fluorouracil 50 mg/ml and mitomycin-c 0.4 mg/ml at the site of treatment, 90° and 180° from centre of treated area.
- 147 Fig 57 Photographs of fibroblast outgrowths from subconjunctival tissues treated with distilled water, 5-fluorouracil 50 mg/ml and mitomycin-c 0.4 mg/ml.
- 149 Fig 58 Graphs of fibroblast outgrowths from scleral biopsies taken one hour, 5 days and 30 days after surgery with intraoperative water (control), 5-fluorouracil 50 mg/ml and mitomycin-c 0.4 mg/ml at the site of treatment, 90° and 180° from centre of treated area.
- 150 Fig 59 Graphs of fibroblast outgrowths from corneal biopsies taken one hour, 5 days and 30 days after surgery with intraoperative water (control), 5-Fluorouracil 50 mg/ml and mitomycin-c 0.4 mg/ml at the site of treatment, 90° and 180° from center of treated area.
- 152 Fig 60 Effects of TGF- $\beta$ 1 on untreated fibroblasts. RNA levels of collagen  $\alpha$ 2, lysyl oxidase and TGF- $\beta$ 1. Autoradiograms after Northern blotting and hybridisation with P<sup>32</sup> cDNA probes.
- 153 Fig 61 Effects of TGF- $\beta$ 1 on fibroblasts growth arrested with 5-fluorouracil. RNA levels of collagen  $\alpha$ 2, lysyl oxidase and TGF- $\beta$ 1. Autoradiograms after Northern blotting and hybridisation with P<sup>32</sup> cDNA probes.
- 166 Fig 62 Growth factors and ocular fibroblast proliferation relative to levels in aqueous humour.

- 167 Fig 63 Growth factors and ocular fibroblast migration relative to levels in aqueous humour.
- 168 Fig 64 Growth factors and ocular fibroblast collagen production relative to levels in aqueous humour.
- 182 Fig 65 Different healing profiles after glaucoma filtration surgery
- 183 Fig 66 Postulated effect of a single five minute application of 5-fluorouracil on different healing profiles
- 184 Fig 67 Postulated effect of a single five minute application of mitomycin-c on different healing profiles



## List of Abbreviations

ABC	:	Avidin biotin complex
AEC	:	3-Amino-9-ethylcarbazole
BSA	:	Bovine serum albumin
BSS	:	Balanced salt solution
CGy	:	CentiGrays
CsCL	:	Caesium chloride
DAB	:	3',3'-Diaminobenzidine tetrachloride
DEPC	:	Diethylpyrocarbonate
DMEM	:	Dulbecco's modified Eagle's medium
DNA	:	Deoxyribonucleic acid
EDTA	:	Ethylenediaminetetraacetic acid
EGF	:	Epidermal growth factor
ELISA	:	Enzyme-linked immunosorbent assay
aFGF	:	acidic fibroblast growth factor
bFGF	:	basic fibroblast growth factor
5-FU	:	5-fluorouracil
5-FUrd	:	5-fluorouridine
FCS	:	Foetal calf serum
HBSS	:	Hank's balanced salt solution
Hepes	:	N-2-hydroxyethyl;piperazine-N'-2-ethanesulfonic acid
HTF	:	Human Tenon's fibroblast
MOPS	:	3-[N-morpholino] propanesulphonic acid, sodium acetate, EDTA
NaB	:	Sodium butyrate
NCS	:	Newborn calf serum
NGS	:	Normal goat serum
PBS	:	Phosphate buffered saline
PCNA	:	Proliferating cell nuclear antigen
RNA	:	Ribonucleic acid
RTF	:	Rabbit Tenon's fibroblast
SEM	:	Standard error of the mean
SD	:	Standard deviation
SSC	:	Saline-sodium citrate buffer
TGF- $\alpha$	:	Transforming growth factor alpha
TGF- $\beta$	:	Transforming growth factor beta

## Acknowledgements

I would like to thank my supervisor Professor Ian Grierson for his tremendous help, guidance and support throughout the course of the work for this thesis. I would also like to thank Professor Gregory Schultz PhD for his help and guidance during my time at the Institute for Wound Research at the University of Florida. Professor Alec Garner and Professor Susan Lightman very kindly provided me with the facilities of their departments. I would also like to acknowledge the scientists in their research groups who took so much time to teach and explain the various scientific techniques which I subsequently carried out for this thesis. They include Helen Robey, Dr Andrea Porter PhD, Shona Ward, Madelaine Nobbs, Bob Alexander MPhil, Dr Ghassan Sheraidah PhD, Dr Sally MacKay PhD, Dr Michael Rossi PhD, and Dr Nasser Chegini PhD. I would also like to acknowledge the help given to me by the other members of the groups including Bill Doyle MD PhD, Fran Smith MD, Vicki Scott and Sue McGorray PhD, whose statistical advice was invaluable.

My clinical colleagues have also been very supportive of my work and their discussion of projects has been essential for the development of my work. I would like to thank my mentor Mr Noel Rice for his unfailing support and advice and the privilege of working with the children with glaucoma. The children with glaucoma provide the inspiration to continue laboratory research in the search for new and better treatments, and an improved understanding of scarring. I would also like to thank Mr Roger Hitchings from Moorfields Eye Hospital and Professor Mark Sherwood from the University of Florida. Mr Peter Watson very kindly supplied samples of aqueous humour from patients with glaucoma.

This thesis would not have been possible without the financial support and encouragement of the Wellcome Trust through their Vision Research Fellowship scheme: they have supported me in every way throughout the course of this research. Their support gave me the opportunity to explore the power of laboratory science in advancing clinical medicine, and to devise new treatments for our patients now and in the future. I would also like to thank the International Glaucoma Association, the Oxford Ophthalmological Congress (Scholarship 1990), the Violet M Richards Charity, the Moorfields Locally Organised Research Scheme, Action Research, the Iris Fund (Prize 1993) and the Peel Trust, who have supported components of my research.

Finally, I would like to thank my parents, my wife Peggy and my daughter Ruth for the many sacrifices they have endured, so that I have been able to carry out my research. Without them, none of this would have been possible.

## CHAPTER 1 INTRODUCTION

### 1.1 The Glaucomas: current treatments

#### 1.11 The glaucomas

The glaucomas are a group of disorders characterised by optic nerve head damage, visual field loss and an intraocular pressure sufficiently raised to affect the functioning of the optic nerve head. Glaucoma is not a single disease process but rather a large group of diseases, which have in common a characteristic type of damage to the optic nerve head. It is estimated that this group of diseases will be the second most common cause of blindness worldwide, behind cataracts, by the year 2000, affecting people in both developed and developing countries (Leske, 1983; Foster and Johnson, 1990). There are estimated to be at least 250,000 people in the United Kingdom with glaucoma (Crick, 1982), and nearly 2 million in the United States of America, with an estimated annual direct and indirect health care cost of \$2 billion (Guzman et al, 1992). These figures will increase as the proportion of elderly increase in the population, since the prevalence of glaucoma rises sharply with increasing age.

Although many theories for the pathogenesis of optic nerve damage have been postulated, the major risk factor for glaucomatous optic nerve damage is the level of intraocular pressure. The higher the intraocular pressure, the greater the risk of optic nerve damage (Armaly et al, 1980; Sommer, 1989). Most treatment is aimed at reducing the intraocular pressure.

#### 1.12 Maintenance of normal intraocular pressure

The eyeball is filled with fluid (aqueous humour) which is produced by the ciliary body. The aqueous then flows from the posterior chamber between the lens and the iris into the anterior chamber and via the trabecular meshwork into draining vessels. In the commonest form of glaucoma in western communities - known as primary open angle glaucoma - the intraocular pressure rises due to an increase in outflow resistance at the level of the trabecular meshwork and beyond. The trabecular meshwork is populated by cells (trabeculocytes) which can phagocytose material that builds up in the trabecular meshwork (Grierson and Lee, 1973). In primary open angle glaucoma, it is thought that the number of these cells is reduced leading to an accumulation of extracellular material which gradually obstructs trabecular outflow (Grierson et al,

1982; Grierson and Howes, 1987; Alvarado et al, 1984). Intraocular pressure can be lowered by reducing aqueous production or increasing the outflow.

### **1.13 Reduction of intraocular pressure**

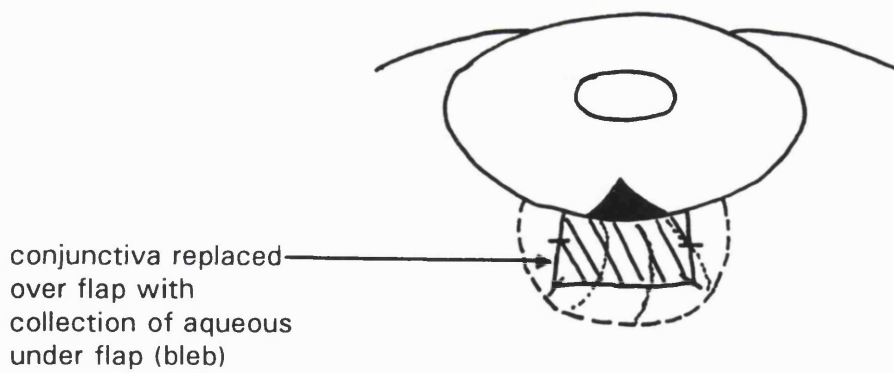
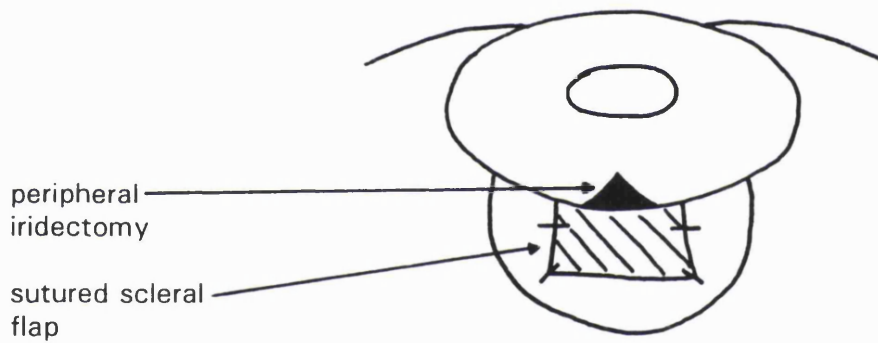
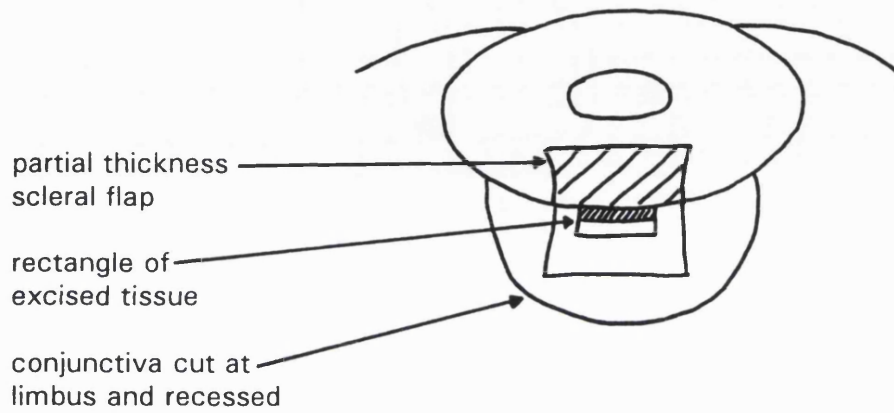
There are three main categories of treatment, medical, laser and surgery. Medical treatment includes topically applied and systemic drugs. Topical drugs include  $\beta$ -blockers which reduce aqueous secretion, parasympathetic agonists, such as pilocarpine, which increase aqueous outflow and sympathetic agonists, such as adrenaline, which primarily increase outflow. Oral drugs include acetazolamide, which reduces aqueous secretion by inhibiting carbonic anhydrase. Laser trabeculoplasty, in which laser burns are applied to the trabecular meshwork, increases the aqueous outflow. Finally, surgical treatment works by creating a new channel for aqueous outflow.

In recent years, evidence has been accumulating that surgery is superior to either laser or medical treatment in lowering the intraocular pressure (Watson and Grierson, 1981) and preserving vision (Jay, 1992; Jay and Allan, 1989; Jay and Murray, 1988; Migdal et al, 1993). In addition, successful surgery results in a better quality of life for patients compared to medical treatment (Lichter et al, 1991), and the use of topical medication (eyedrops) increases the chance of subsequent surgical failure (Lavin et al, 1990). Furthermore, in many developing countries of the world, surgery is the only practical treatment to prevent blindness from glaucoma. New methods of creating the surgical fistula are now in development, which may make surgery much quicker and more readily available and accessible.

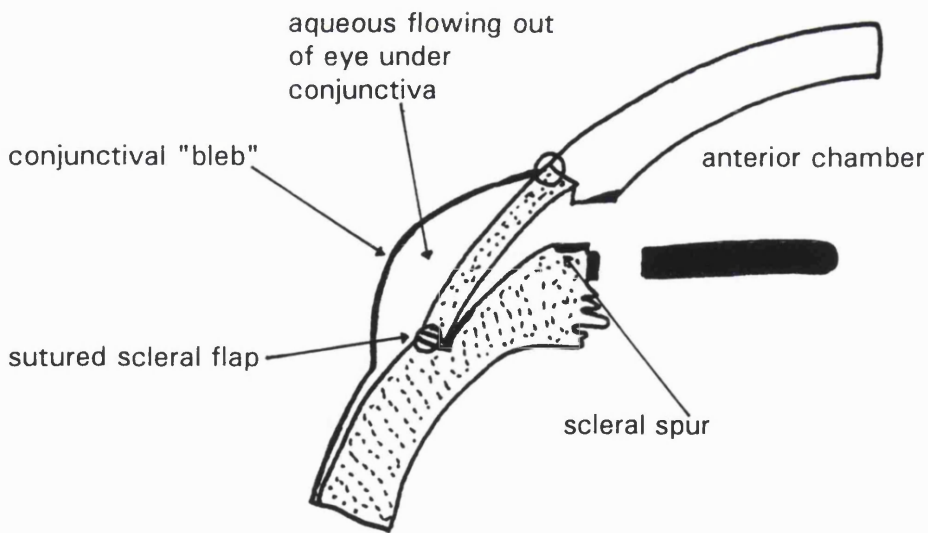
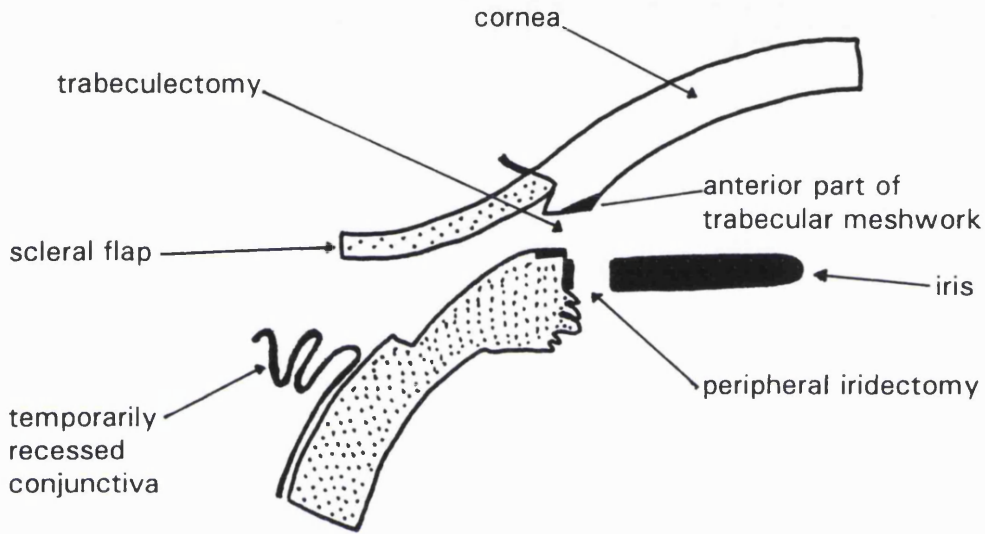
### **1.14 Surgical reduction of intraocular pressure: glaucoma filtration surgery**

Glaucoma filtration surgery essentially involves the creation of a new drainage channel for the aqueous humour. The commonest form of the procedure (Cairns, 1968) (Watson modification 1972) involves making an incision in the conjunctiva, dissecting open the subconjunctival space and making a trapdoor incision in the sclera up to the junction between the cornea and the sclera. (Figure 1,2 and 3) The eye is entered and a block of corneo-scleral tissue removed to create a new channel for aqueous outflow, then the trapdoor is sutured down to create a valve mechanism. The conjunctival incision is then closed and the aqueous allowed to flow out under the conjunctiva. The aqueous may then flow away subconjunctivally,

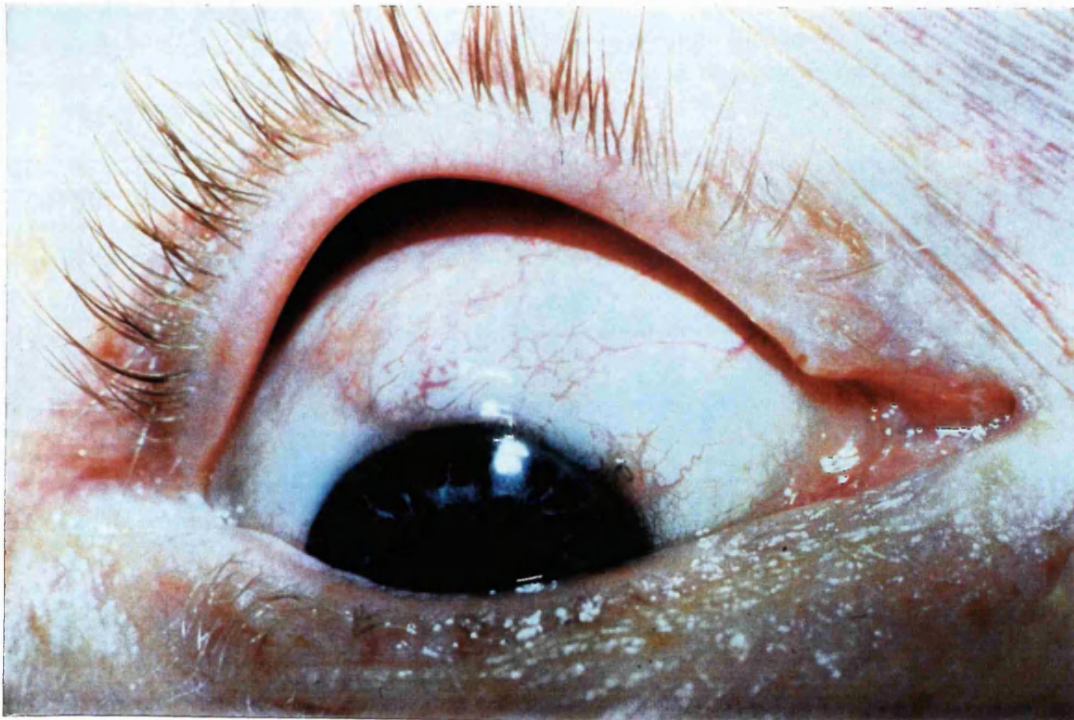
**Figure 1** Diagram of fornix based glaucoma filtration surgery anteriorly viewed. Technique based on Watson modification of Cairn's trabeculectomy (Watson, 1972) (original diagram design courtesy of Broadway,D). The conjunctival incision can also be made in the fornix with the base at the limbus (limbus based flap).



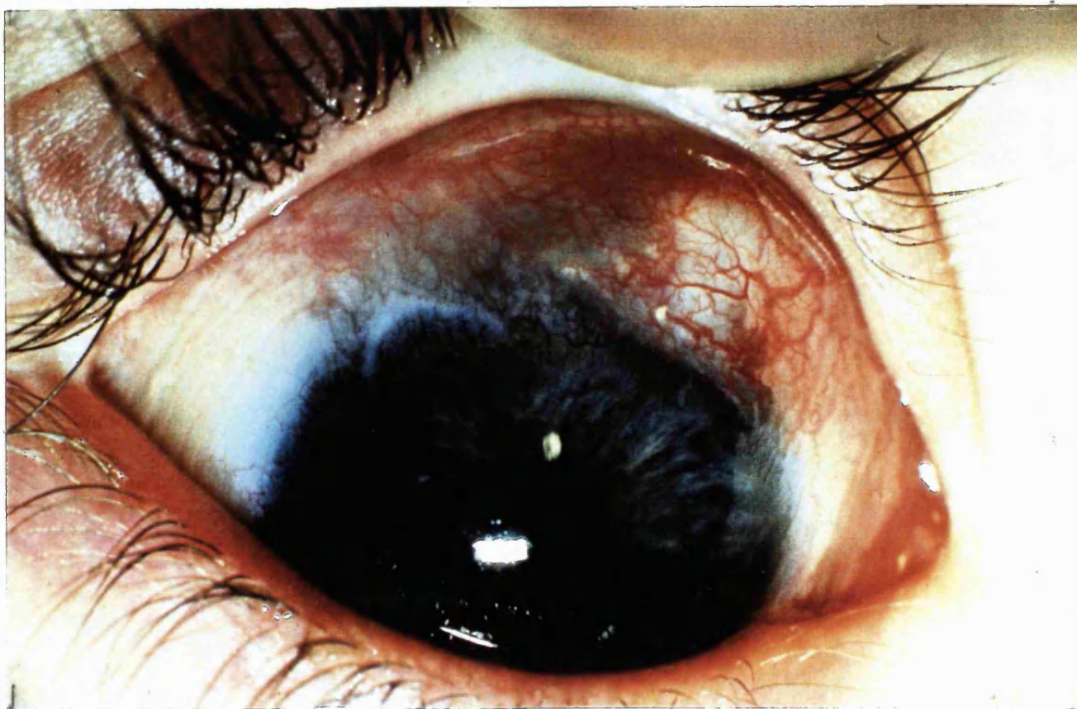
**Figure 2** Diagram of fornix based glaucoma filtration surgery (cross sectional view). Technique based on Watson modification of Cairn's trabeculectomy (Watson, 1972) (original diagram design courtesy of Broadway,D). The conjunctival incision can also be made in the fornix with the base at the limbus (limbus based flap).



**Figure: 3 Successful and failed glaucoma filtration surgery.**



Successful glaucoma filtration surgery. There is a diffuse collection of aqueous under the conjunctiva (bleb) and the intraocular pressure is 15 mmHg off all medications.



Failed glaucoma filtration surgery. The conjunctiva is stuck down to the underlying sclera with scar tissue and there is no collection of aqueous under the conjunctiva.

through aqueous veins, through lymphatics channels, transconjunctivally or via the suprachroidal space (Benedikt, 1979).

## **1.2 Healing after glaucoma filtration surgery**

The successful lowering of intraocular pressure after filtering surgery relies heavily on the nature of the healing response following the surgery. New scar tissue, mainly in the subconjunctival space, blocks the flow of fluid through the conjunctival tissues and subconjunctival planes (**Figure 3**) (Addicks et al, 1983; Hitchings and Grierson, 1983). It is variations in this healing response that result in the majority of failed filtering procedures. Several risk factors are associated with an increased risk of surgical failure due to scarring and these are shown in **Figure 4**. The reasons for the increased risk of post-operative scarring in association with these risk factors is still not fully clear.

Furthermore, just as important as absolute failure is the suboptimal lowering of the intraocular pressure. There is evidence that the lower final intraocular pressure after surgical rather than medical treatment is associated with a better visual prognosis. (Migdal et al, 1993) The concept of pressure as a risk factor for visual impairment suggests that aiming for as low as possible an intraocular pressure reduces the risk of visual damage (Sommer, 1989; Anderson, 1989). The healing response is the major determinant of the final intraocular pressure. In terms of the entire glaucoma population undergoing surgery, this is probably a much more important problem epidemiologically than the far smaller but highly visible group that completely fail surgery. Thus, the healing response is probably the single most important modifiable factor determining outcome in every patient undergoing glaucoma filtration surgery.

### **1.21 Summary of events after filtration surgery**

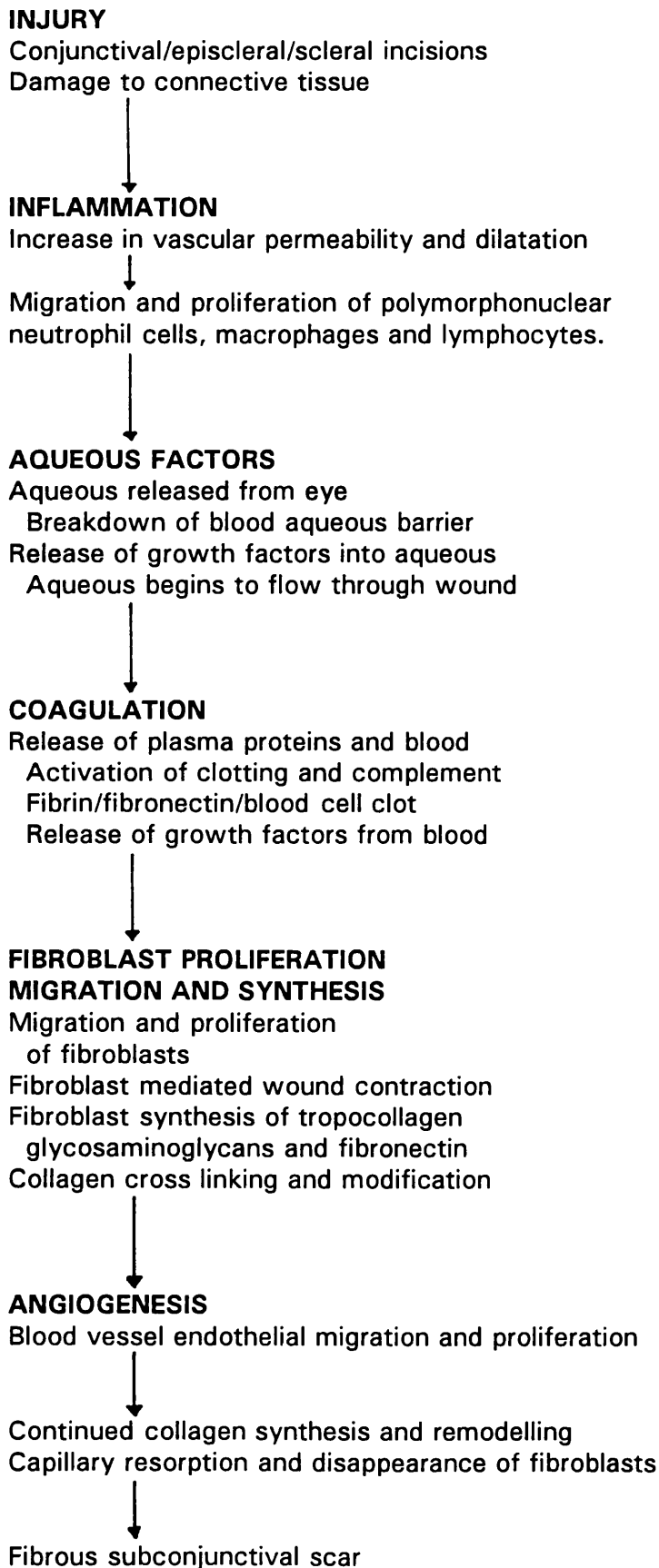
The sequence of events following glaucoma filtering surgery can be illustrated in a diagrammatic form, although many of the events obviously occur concurrently (**Figure 5**). Most of the events are similar to dermal wounding, except in specific areas which are outlined below. When incisions are made in the conjunctiva and sclera, connective tissue and blood vessels are damaged. This results in the release of blood cells and plasma proteins into the damaged site, and also inflammatory mediators such as bradykinin and complement derived anaphylotoxins. The clotting system is activated,



**Figure 4 Risk factors for failure due to scarring after glaucoma filtration surgery**

- Topical medications > 3 years  
(Lavin et al, 1990; Longstaff et al, 1990; Miller and Rice, 1991)
- Age < 40  
(Schwartz and Anderson, 1974; Stewart et al, 1979; Inaba, 1982; Heuer et al, 1984; Sturmer et al, 1993)
- Afro-Caribbean  
(Ilf, 1944; Berson et al, 1969; Merritt, 1980; Miller and Barber, 1981)
- Previous failed filtration surgery  
(The Fluorouracil Filtering Surgery Study Group, 1989)
- Uveitis  
(Heuer et al, 1986)
- Neovascularisation  
(Heuer et al, 1986)
- Aphakia/pseudophakia  
(The Fluorouracil Filtering Surgery Study Group, 1989)

**Figure 5**      **Sequence of events in wound healing after glaucoma filtration surgery.**  
**(simplified) Events have overlapping time duration**



including the aggregation of platelets, and a blood clot forms around the damaged areas. The platelets also release biologically active components into the wound area (Bode et al, 1981; Clemmons et al, 1983; Deuel et al, 1981; Deuel et al, 1982a; Deuel and Huang, 1984; Assoian and Sporn, 1986). When the eye is entered, some degree of blood aqueous barrier breakdown occurs, which also brings in serum factors to the wound site. Aqueous then begins to flow through the wound site, and this is where the filtration surgery wound is fundamentally different to the dermal wound. The aqueous can have significant modulating effects on the cellular components of the healing process.

Polymorphonuclear cells move into the wound area and accumulate, and phagocytose any contaminating bacteria and digest blood clot material. Some neutrophils lyse and release proteolytic enzymes including collagenases that break down collagen, the fibrin network and tissue debris (Horowitz et al, 1977). The polymorphonuclear cells are followed by lymphocytes and monocytes within 24 hours, and are brought there by a variety of stimulatory factors, including components of the complement system such as C5, C5a, C6, C7 (Robbins et al, 1984), fibronectin and platelet-derived chemotactic factors (Tzeng et al, 1984; Norris et al, 1982). Monocytes transform into macrophages and begin ingesting tissue debris and lysed neutrophils. Macrophages in turn release a variety of biologically active substances. Quiescent fibrocytes in the connective tissue become activated so becoming fibroblasts. The fibroblasts then subsequently migrate into the wound area, stimulated by a variety of substances, and begin proliferating. Fibroblasts are relatively late arrivals, appearing after inflammatory cells are well established. They reach optimal numbers within the first 1-2 weeks, plateau then slowly decrease in numbers over a period extending up to several months (Grierson et al, 1988). As they migrate they probably cause wound contraction. The mechanism of this contraction is still controversial (McCarthy et al, 1988). The fibroblasts also begin synthesizing the extracellular materials that are the components of scar tissue including glycosaminoglycans, glycoproteins such as fibronectin, and procollagen molecules which are then linked together. Endothelial cells proliferate and migrate into the wound area resulting in new vessel formation. The end result is fibrovascular granulation tissue. Re-epithelialisation occurs over the incision site, but this is not a major component of the healing process after glaucoma filtration surgery.

This tissue is then remodelled continuously with continued synthesis and breakdown of the extracellular matrix, a process which can extend over months and years. The scar tissue becomes less cellular and the matrix components become

increasingly prominent. This remodelling process is mediated by the synthesis of extracellular matrix and the breakdown of the matrix with matrix metalloproteinases such as collagenase. Eventually, most of the active cellular processes cease and the final result is subconjunctival scar. It is variations within this process that lead to the success or failure of a filtering bleb. The different components of this balance will now be considered.

## 1.22 Healing after filtration surgery in the human

Successful filtering surgery in man is usually associated with a subconjunctival accumulation of aqueous humour, or a bleb (**Figure 3**). The conjunctiva over the bleb may be thin (more commonly after full thickness procedures without a valve flap made from sclera) or thick. This influences to some degree whether the aqueous escapes transconjunctivally (Kronfeld, 1952; Seidel, 1921) or through the subepithelial vessels and lymphatics (Kronfeld, 1952; Benedikt, 1979). The histology available from blebs in humans is inevitably very limited and there have only been a few studies on post mortem eyes or biopsies taken from failed blebs. In a functioning bleb, Addicks described loosely arranged connective tissue under the conjunctival epithelium (Addicks et al, 1983). Microcystic spaces, seen clinically using the slit lamp, corresponded to subconjunctival microcysts which are probably channels for the passage of aqueous humour and indicate a clinically functioning bleb. Electron microscopy revealed normal collagen fibrils with 50 to 200  $\mu\text{m}$  spaces throughout the stroma. There were no junctions between conjunctival epithelium that would impede fluid flow.

Teng and colleagues (Teng et al, 1959) examined six post mortem eyes that had had successful filtration surgery with full thickness procedures. They described loose perivascular degeneration of episcleral and subconjunctival capillaries, which they thought facilitated filtration by increasing aqueous absorption directly through the vessel wall, although this was not confirmed by Addicks study (Addicks et al, 1983). In addition, they felt the proliferating endothelium of cut capillaries contributed to the formation of anastomotic channels which could communicate directly with the deep scleral venous plexus. In contrast to this, failed or failing blebs showed abnormally thickened dense collagenous connective tissue beneath the conjunctival epithelium (Addicks et al, 1983). However, the epithelium was relatively normal. Occasionally, blebs become encapsulated, these being described as 'cysts of Tenons capsule' (van Buskirk, 1982). The walls of these cysts are fibrous and avascular, consisting of sheets of fibrous connective tissue with areas of active proliferation of fibroblasts.

Unlike a true cyst, these cysts are not lined by epithelium, but by a cellular material which includes fibrin. Unlike totally failed blebs, these encapsulated blebs may be treated medically with some success (Sherwood et al, 1987).

Early onset failures (less than six months post surgery) from Moorfields Eye Hospital showed a marked inflammatory response in the conjunctival dermis and Tenons capsule (Hitchings and Grierson, 1983). The infiltrates consisted mainly of macrophages and lymphocytes. Myofibroblasts were abundant and some of the fibroblasts had well developed rough endoplasmic reticulum, suggesting an actively metabolizing cell. Many fibroblasts had plentiful microfilaments, their appearance being associated with active scar formation (Montandon et al, 1973). This tissue was thickened with the deposition of new collagen, which consisted mainly of thin fibrils. Normal but leaky blood vessels were evident. Late onset failures (greater than six months post surgery) surprisingly showed a thick lining of fibrin. The lining showed only an occasional fibroblast. The bleb was encapsulated in part by hypocellular fibrous tissue which consisted of irregular bundles of collagen. This capsule separated the bleb from a relatively normal conjunctiva and Tenon's capsule. Only the occasional mononuclear inflammatory cell was present in the dermis.

Although useful, these studies only give us a limited window into the cellular processes underlying wound healing after glaucoma filtration surgery. Hence, a variety of animal and cell culture models have been used to increase the understanding of the cellular events following glaucoma filtering surgery and to test the efficacy of a variety of techniques and chemotherapeutic agents. The information available from these studies is reviewed in the subsequent sections of this thesis.

### **1.23 The role of blood and the clotting system**

The blood clotting system is an essential component of the healing process. The clotting cascade is activated after vascular damage and this results in the formation of a clot containing fibrin, fibronectin and blood cells which line the wound and particularly the wound edges. Fibrin is derived from plasma fibrinogen which, upon contact with coagulation factors, platelet-derived molecules or tissue procoagulants, cross-links and clots to fill the injured area (Clark et al, 1983). Fibronectin is also covalently linked to the fibrin polymer, forming a fibrin-fibronectin matrix (Grinnell, 1984; Kurkinen et al, 1980). Fibronectin and fibrin probably serve as a framework on which collagen is laid down (Grinnell, 1984; McDonald et al, 1982), and they play an important role in determination of the scar size.

Platelets and extravascular coagulation promoting factors (Dvorak et al, 1985; Maynard et al, 1975) promote rapid clotting of trapped plasma and blood proteins. Platelets are derived from non-nucleated megakaryocytes in the bone marrow. They cannot synthesise protein and function as storage units for various mediators. When exposed to agents such as damaged collagen, thrombin and adenosine diphosphate (ADP), platelets release soluble clotting factors and molecules which stimulate cellular activity, including migration and proliferation in variety of cell types (Ross et al, 1986). Platelets attach to the damaged endothelial surfaces of blood vessels through direct interaction with polymerized collagen fibrils and von Willebrand factor (factor VIII), which is synthesized by endothelial cells. Thromboxane A<sub>2</sub> is released by the platelets enhancing platelet aggregation and attachment to the vascular endothelium (Hamberg et al, 1975), and is then followed by platelet degranulation (Samuelsson et al, 1978).

In normal, undamaged vascular tissue, the cyclooxygenase pathway leads to in the production of prostacyclin and thromboxane A<sub>2</sub>. In undamaged vessels, there is a higher ratio of prostacyclin to thromboxane A<sub>2</sub> concentration, which inhibits platelet attachment to the endothelium. Prostacyclin prevents platelet aggregation and degranulation, and vasodilation through a mechanism involving adenylyl cyclase (Samuelsson et al, 1978; Kulkarni and Srinivasan, 1983). When vessels are damaged by surgery, the production of prostacyclin by the local vascular endothelial cells is reduced which, results in a fall in the prostacyclin/thromboxane A<sub>2</sub> ratio. This promotes platelet attachment. Other agents including neurotransmitters, adrenaline, noradrenaline and acetylcholine also enhance platelet attachment to the vascular tissue through induction of endothelial cell changes (Boucek, 1984).

A variety of factors are released including platelet-derived growth factor, epidermal growth factor, transforming growth factor  $\beta$  and fibroblast growth factor (Ross, 1986). These have effects which include the stimulation of proliferation and chemotaxis of monocytes (Deuel et al, 1982b), fibroblasts (Seppa et al, 1982) and vascular smooth muscle cells (Ross, 1989; Heldin and Westermark, 1984). If the blood aqueous barrier is impaired, or the blood vessels continue to leak at the site of injury, there may be a continued inflow of stimulatory factors and clotting factors. Evidence of leaking blood vessels has been found in failing blebs examined histologically (Hitchings and Grierson, 1983).

A fibrin based clot is the result of activation of the clotting system. In models of general wound healing, the greater the amount of fibrin scaffold in the wound, the greater the amount of scar formation (Dvorak, 1986). A delay of fibrinolysis promotes fibroblast proliferation and fibrosis (Soshan and Gross, 1974). Fibrin clots have the

potential to hold active compounds in the fluid phase of the fibrin gel and shield them from inhibitors and metabolic turnover (Senior et al, 1986). Substantial amounts of active thrombin can become sequestered within the fibrin gel, which is a potent growth factor for chick embryo fibroblasts (Perdue et al, 1981). Fibrin also stimulates the proliferation of embryonic rat fibroblasts (Kittlick, 1979), but the effects on Tenon's capsule fibroblasts have not been studied. It may be that a microenvironment of many mediators can be established within the fluid phase of fibrin clots, from which many biological activities such as chemotaxis and growth stimulation can be expressed. Inhibitors of fibrinolysis enhance the formation of connective tissue, with increased tensile strength of the wound tissue in a rat model of wound healing (Kwaan and Astrup, 1969). Aqueous humour contains promoters of fibrinolysis (Tripathi et al, 1988) and fibrinolytic factors are found in the anterior segment of the eye (Tripathi et al, 1987), including the trabecular meshwork cells (Shuman et al, 1988).

Fibrin is a prominent feature of filtering surgery failure in animal models, where healing is very aggressive. Miller et al found fibrin in the aqueous filling the bleb, and it also lined the bleb in rabbits after experimental filtering surgery (Miller et al, 1989). This fibrin appeared to form a scaffold which contained erythrocytes, inflammatory cells and fibroblasts. Adjacent to the fibrin was new collagen in the bleb wall. The fibroblasts formed layers on the fibrin. Desjardins found some evidence of fistula blockage by fibrinous material in a monkey model of filtration surgery (Desjardins et al, 1986). Using antibodies against fibrin/fibrinogen, Jampel and coworkers confirmed the identity and abundant presence of fibrin/fibrinogen in the monkey after experimental filtration surgery (Jampel et al, 1988). This is not entirely applicable to the situation in man, as the blood aqueous barrier in animals is much more fragile (Bito, 1984), but may be one of the reasons for the rapid failure of drainage surgery in animal models.

Despite the differences between man and animals, fibrin is also found in failing or failed filtering surgery in man. Failure of trabeculectomies may be characterised by the formation of a cyst of Tenon's capsule, which may occur several weeks after surgery. Histology of these cysts has revealed fibrin (van Buskirk, 1982) in the failing bleb. In a histological study of blebs undergoing revision for failed fistulising surgery at Moorfields Eye Hospital, fibrin was found lining some of the blebs even more than nine months after surgery (Hitchings and Grierson, 1983).

## 1.24 The role of aqueous humour

The glaucoma filtration procedure differs from other surgical wounds in that the site of filtering surgery is bathed with aqueous humour. Indeed, it is the continued flow of this fluid through the wound that is essential and part of the definition of successful surgery. Fluid around a wound has been shown to have a direct bearing on the healing process (Lawrence et al, 1986a). Conjunctiva dissected from the underlying sclera rapidly scars down, unless there is aqueous under the conjunctiva and Tenons capsule. So, the cellular effects of the aqueous would seem to be crucial to the success of filtering surgery.

The role of normal aqueous humour (primary aqueous) is controversial. Albrink and Wallace (Albrink and Wallace, 1951) and Kornblueth and Tenenbaum (Kornblueth and Tenenbaum, 1956) found that normal aqueous did not appear to be stimulatory to fibroblast cells in culture. In addition, it has been postulated that aqueous may have a degenerative effect. Chi, Teng and Katzin (Chi et al, 1960) noted collagen degeneration in non-encapsulated pieces of sclera implanted into the anterior chamber of rabbits eye. They also reviewed the post-mortem histology in six eyes that had undergone successful filtration surgery. The presence of thin atrophic conjunctiva over certain blebs, the lack of fibroblasts and the paucity of collagen with perivascular degeneration led them to postulate that aqueous had a degenerative effect on collagen (Teng et al, 1959). However, more recent studies with use of electron microscopy have been unable to support the finding of collagen degeneration (Addicks et al, 1983). Herschler postulated the presence of an inhibitory factor in the aqueous humour, which prevented fibroblast proliferation. He felt this inhibitory factor was present in normal aqueous humour, but was absent in some patients with glaucoma (Herschler, 1981; Herschler et al, 1980). He attempted to correlate the presence or absence of this inhibitory behaviour with the final outcome of the filtering procedure with some success (Herschler et al, 1980). As yet, no inhibitor has been isolated or identified biochemically in the aqueous humour.

On the other hand, Joseph and colleagues also showed that primary aqueous humour stimulated mitogenic activity of human Tenon's capsule fibroblasts at concentrations from 2% to 100% (Joseph et al 1988), but with reduced survival of the fibroblasts at high aqueous concentrations (Burke et al, 1982). Jiang and coworkers noted both a promotion and inhibition of cell proliferation (Jiang et al, 1983). Apart from the effects on fibroblast proliferation, aqueous also stimulates fibroblast chemotaxis. Joseph and colleagues (1989a) also found that human aqueous humour



taken before surgery (primary aqueous) from patients undergoing cataract surgery was also chemoattractant to human ocular fibroblasts. However, the nature of the chemoattractant(s) have only been partially characterized (Joseph et al, 1989b).

Normal aqueous humour contains a variety of growth factors including Fibroblast Growth Factor (FGF), Transforming Growth Factor  $\beta$  (TGF- $\beta$ ), Insulin-like Growth Factor (IGF) and possibly Epidermal Growth Factor (EGF) (Figure 6). The role of these growth factors in the aqueous on the healing process after glaucoma filtration surgery is uncertain. The aqueous from patients undergoing trabeculectomy, either as a primary procedure or after failed medical treatment, was more chemoattractant than a control cataract group, but this did not reach statistical significance (Joseph et al, 1989a). Aqueous taken from patients who had undergone previous failed glaucoma surgery was significantly more chemoattractant to human ocular fibroblasts. Radius and colleagues found that monkey aqueous humour did not normally support fibroblast proliferation. However, after experimental filtering surgery, the proliferation of fibroblasts was still supported by the post-operative aqueous (secondary aqueous) at two months in some cases (Radius et al, 1980).

From the study of Joseph and colleagues, it was uncertain whether the increased chemotactic activity seen in the aqueous humour of the patients who had undergone failed surgery predated the unsuccessful surgery or occurred subsequently (Joseph et al 1988). However, the stimulatory effect of secondary aqueous may be due in part to the breakdown in the blood aqueous barrier, which may be damaged by ocular surgery (Campochiaro and Conway, 1981) such as cataract extraction, for at least a month afterwards (Miyake et al, 1984), and procedures such as cyclocryotherapy (Jacomina et al, 1985) and probably the increasingly popular procedure of Neodymium-YAG cyclophotocoagulation. Aqueous humour from traumatized eyes stimulates cell division in the lens epithelium (Reddan et al, 1979) and vitreous from animal eyes with induced blood retinal barrier breakdown stimulates cellular chemotaxis and proliferation (Campochiaro et al, 1986). Certain agents used to inhibit wound healing after filtering surgery, such as steroids (Miller et al, 1989), may help to stabilize this barrier while others, such as radiation, may destabilise it (Miller et al, 1990).

### **1.25 Characteristics of stimulatory factors found in human aqueous humour**

**Fibroblast Growth Factor:** The fibroblast growth factors are a group of heparin-binding

**Figure 6 Stimulatory biological molecules detected in intraocular fluids**

Growth factor	Concentration	Fluid	Reference
Fibroblast Growth Factor (basic) (bFGF)	0.70-1.40 ng/ml Undetectable to 54ng/ml	Aqueous Vitreous	Tripathi et al 1988 1990 Sivalingam et al 1990
Epidermal Growth Factor (EGF)	not detectable 0.62-1.4 ng/ml	Aqueous	Ohashi et al 1989 Watanabe et al, 1989 Tripathi et al, 1990 Parelman et al, 1990
Transforming Growth Factor- $\beta$ (TGF- $\beta$ ) Mostly $\beta_2$ isoform	0.2-1ng/ml 2.3-8.1ng/ml	Aqueous Vitreous	Granstein et al, 1990 Jampel et al 1990 Knisley and Granstein, 1990 Connor et al, 1989
Insulin-like Growth Factor (IGF)	24 + /-7mU/ml 1.0-45.6ng/ml	Aqueous Vitreous	Castro et al, 1990 Beebe et al, 1980,1987 Meyer-Schwickerath, 1993
Transferrin (Tf)	0.4-2.8mg/dl	Aqueous Vitreous	Dernouchamps, 1982 Tripathi et al, 1989, 1990,1990 Yu and Okamura, 1988
Interleukin-6	< 10 units/ml	Aqueous	Murray et al, 1990
Fibronectin	2.46 $\mu$ g/ml	Conditioned media from meshwork cells Aqueous	Polansky et al 1984 Worthen 1982 Zetter et al 1978 Reid et al 1982 Kenney et al 1986

\* ND = not determined

growth factors. The best characterised are two closely related forms: acidic FGF (aFGF), a 146 amino acid polypeptide with an apparent molecular weight (MW) of 15,000 (Esch et al, 1985), and basic FGF (bFGF), which is a 140 amino acid polypeptide with an approximate MW of 16,000 (Esch et al, 1985). They are also known as FGF-1 and FGF-2 respectively. At least three other related forms also exist (FGF 3, 4 and 5). The FGFs affect cell proliferation and differentiation (Gospodarowicz et al, 1977; Gospodarowicz et al, 1986). In addition, the family probably share a common receptor (Olwin and Hauschka, 1989). The FGFs enhance corneal epithelial (Steinmann et al, 1990) and endothelial (Gospodarowicz et al, 1986) healing, and are highly angiogenic (Folkman and Klagsbrun, 1987). Acidic FGF (aFGF) and basic FGF (bFGF) have a 55% amino acid sequence homology.

In the eye, an important role for basic FGF has been documented in the processes of tissue repair, wound healing and angiogenesis (Gospodarowicz et al, 1985; Tripathi et al, 1990). Tripathi and colleagues identified a polypeptide that is indistinguishable from bFGF in the aqueous humour of patients undergoing cataract surgery (Tripathi et al, 1988; Tripathi et al, 1989; Tripathi et al, 1990a). Using radioimmunoassay, the same authors determined levels of bFGF in aqueous humour from normal human eyes ranging from 700 to 1,400 pg/ml. It is probable that bFGF is derived from the eye, as extracts of the iris choroid lens and vitreous body have a stimulatory effect on the epithelium of the bovine lens (Barritault et al, 1981). Northern analysis of mRNA from cell extracts of iris melanocytes corneal epithelium, and lens epithelium have demonstrated the presence of the transcripts of the bFGF gene (Schweigerer et al, 1988; Plouet and Gospodarowicz, 1990). Basic FGF stimulates a variety of ocular cells. Human trabecular meshwork cells are stimulated to mitose, at FGF concentrations of 1 ng/ml, increase in the rate of mitoses occurs with a 10 ng/ml concentration of basic FGF (Tripathi et al, 1990). Basic FGF also stimulates the proliferation *in vitro* of corneal endothelial cells and lens epithelial cells at concentrations as low as 5 pg/ml and 10 pg/ml respectively (Gospodarowicz et al, 1977; Gospodarowicz et al, 1985). Concentrations as low as 0.3 ng/ml induce profuse capillary formation in the rabbit cornea (Gospodarowicz et al, 1979). These levels of bFGF are significantly lower than the levels present in the aqueous humour (700-1,400 pg/ml). Folkman has postulated that the great affinity of bFGF for the extra cellular matrix molecule heparin limits its availability to adjacent cells (Folkman et al, 1988).

Epidermal Growth Factor: EGF is a single chain acidic polypeptide containing 53 amino acid residues, with an approximate MW of 6,000 (Savage et al, 1972). EGF was first

described by Cohen as a protein from the submaxillary glands of male mice that caused premature eyelid opening and tooth eruption in neonatal mice (Cohen, 1962). The EGF receptor is a single chain glycoprotein with an extracellular domain, a transmembrane domain and an intracellular domain (Ullrich et al, 1984). Other growth factors also bind the EGF receptor and these include TGF- $\alpha$  and vaccinia virus growth factor. It stimulates mitogenesis and maturation responses in a variety of ectoderm- and mesoderm-derived tissues (Gospodarowicz, 1981; Cohen, 1987; Fisher et al, 1989; Tripathi et al, 1991b). Within the eyeball, EGF evokes proliferative responses in the corneal epithelium, corneal endothelium and lens epithelium (Gospodarowicz et al, 1977; Reddan and Wilson-Dziedzic, 1983; Tripathi et al, 1990). Application of EGF to the corneal surface induces cellular hypertrophy and stimulates cell division, increasing the rate of re-epithelialisation, and improves wound strength (Burstein, 1987; Rich et al, 1979). EGF increases the production of fibronectin by a range of cells types (Chen et al, 1977). It also stimulates the production of plasminogen activator by various cells (Lee and Weinstein, 1978). It is present in human tear fluid and bathes the conjunctiva (van Setten et al, 1989; Ohashi et al, 1989), although its presence in aqueous humour is uncertain.

There is controversy regarding the level of EGF in aqueous humour. Various levels from undetectable up to 1.4 ng/ml have been reported in aqueous humour from animal and human eyes (Shinoda et al, 1988; Ohashi et al, 1989; Watanabe et al, 1989; Parelman et al, 1990; Tripathi et al, 1991b). The detection of EGF in aqueous may be related to the breakdown of the blood aqueous barrier as Tripathi only detected levels of EGF in aqueous when the iris had been damaged during paracentesis (Tripathi et al, 1991a). Specific binding sites or receptors are present in a variety of structures in the anterior and posterior chambers of the eye including the corneal endothelium, the pigmented epithelium of the iris and the lens epithelium (Gospodarowicz et al, 1977; Couch et al, 1987; Tripathi et al, 1989). Epithelial cells respond to EGF by increasing DNA synthesis (Reddan and Wilson-Dziedzic, 1983). EGF, at a concentration of 10 ng/ml, stimulates rabbit corneal epithelial cells to increase their mitotic rate (Raymond et al, 1986).

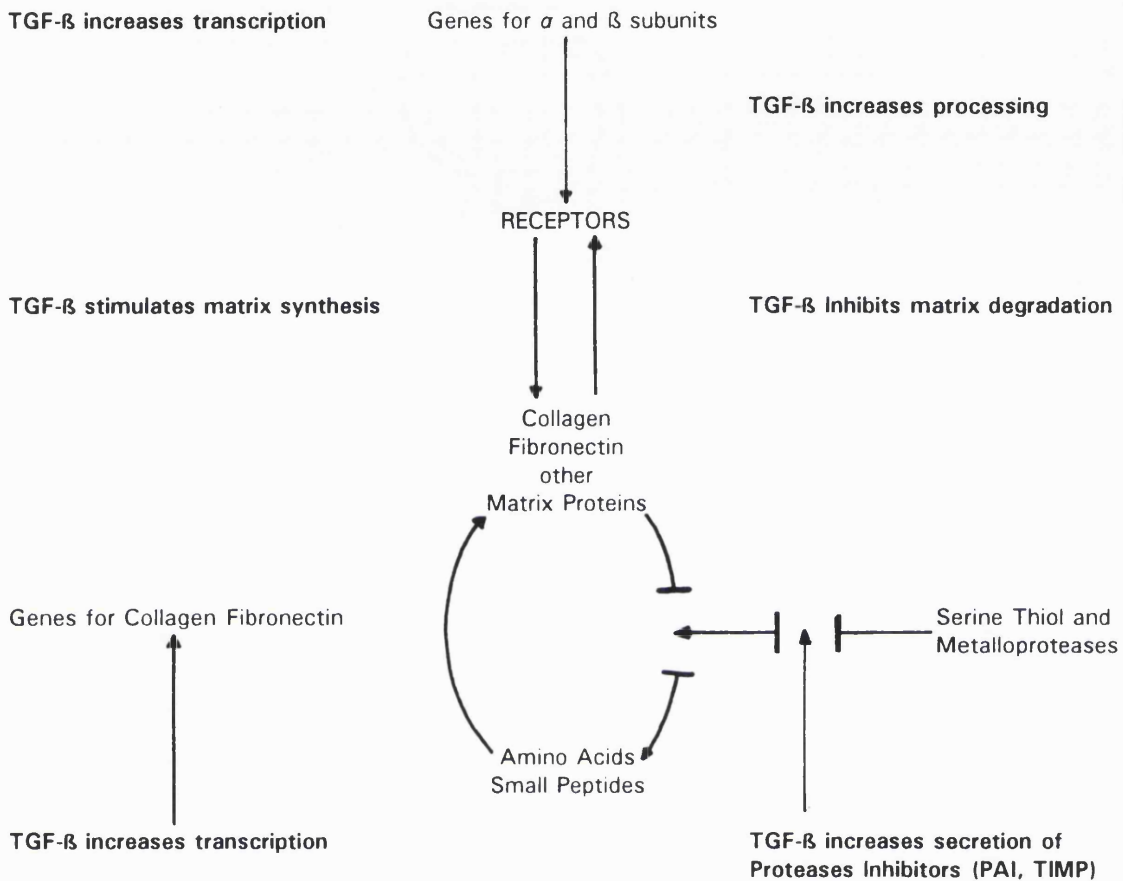
Transforming Growth Factor  $\beta$ : The Transforming growth factor  $\beta$  family consists of five isoforms TGF- $\beta$ 1, TGF- $\beta$ 2, TGF- $\beta$ 3, TGF- $\beta$ 4, and TGF- $\beta$ 5 (Sporn and Roberts, 1990). The first three have been found in mammalian tissue and appear to have similar biological activities. All members of the TGF- $\beta$  family can act as potent growth inhibitory compounds for a wide variety of cells types. Initially isolated from platelets,

TGF- $\beta$ 1 was the first member of this family to be discovered. Therefore, TGF- $\beta$ 1 is the best characterised and is a good prototype for the group. TGF- $\beta$ 1 is composed of two identical chains of 112 amino acids each with a MW of approximately 2,500. It is derived from a large precursor molecule of 390 amino acids, with TGF- $\beta$ 1 being located at the C-terminus. This molecule is processed by cleavage of the proregion, which remains associated with the TGF- $\beta$  prototype forming an inactive complex. In some cells, for instance platelets, a third protein, called latent TGF binding protein (LTBP) is also associated with the inactive TGF- $\beta$  complex (Sporn and Roberts, 1990). TGF- $\beta$ 1 is almost always secreted from cells in the latent form (Sporn and Roberts, 1990). *In vitro* studies suggest that the proteases cathepsin D or plasmin may be involved (Lyons et al, 1988). TGF- $\beta$  is thought to be involved in a wide variety of biological functions, including control of cell proliferation, synthesis of extra cellular matrix components, chemotaxis of inflammatory cells, and angiogenesis. In general, TGF- $\beta$  is thought to be a potent inhibitor of normal epithelial cell proliferation *in vitro*, but is a weak stimulator of mesenchymal cell proliferation (Sporn and Roberts, 1990; Massague, 1990). TGF- $\beta$  has been reported to increase the accumulation of extra cellular matrix *in vitro* by increasing cellular synthesis of protein such as collagen, thrombospondin, fibronectin and elastin (Sporn and Roberts, 1990; Massague, 1990). In addition, TGF- $\beta$  decreases the synthesis of proteases, which degrade the extra cellular matrix, such as collagenase, stromelysin, and plasminogen activator, and increases production of protease inhibitors, such as plasminogen activator inhibitor-1 (PAI-1) and tissue inhibitor of metalloprotease (TIMP) (Massague, 1990) (Figure 7).

TGF- $\beta$  is an extremely potent chemotactic factor for macrophages and fibroblasts, with a peak response *in vitro* in the subpicomolar range (Wiseman et al, 1988). TGF- $\beta$  also inhibits the proliferation of T and B lymphocytes at femtomolar concentrations (Kehrl et al, 1986). The long term effects on the immune system following exposure to elevated or reduced levels of TGF- $\beta$  have not been vigorously explored, but preliminary results suggest that elevated levels of TGF- $\beta$  may act to severely suppress T and B cell levels and functions.

TGF- $\beta$  also has biphasic actions in that it stimulates the proliferation of normal smooth muscle cells at low concentrations, probably through induction of PDGF, whereas higher concentrations of TGF- $\beta$  inhibit proliferation (Moses et al, 1990). Furthermore, many of the *in vitro* effects of TGF- $\beta$  appear to directly oppose its action *in vivo* (Sporn and Roberts, 1990; Massague et al, 1991). Endothelial cell mitosis and

**Figure 7** Mechanism of TGF- $\beta$  enhancement of both the accumulation of extracellular matrix proteins and integrins, including enhancement of synthesis of matrix proteins, inhibition of the degradation of matrix proteins and enhanced synthesis of the receptors for matrix proteins.



**TIMP = tissue inhibitor of matrix metalloproteinases.**  
**PAI = plasminogen activator inhibitor.**

capillary sprouting are inhibited by TGF- $\beta$  *in vitro*, but TGF- $\beta$  induces angiogenesis *in vivo*, probably by an indirect mechanism involving chemotaxis of other target cells such as macrophages, which secrete angiogenic growth factors. TGF- $\beta$  inhibits keratinocytes *in vitro*, but accelerates epidermal regeneration *in vivo*, probably by increasing keratinocyte migration (Jones et al, 1991).

TGF- $\beta$  activity is present in serum and is derived from platelets (Wiseman et al, 1988). Direct examination of platelets shows that they contain particularly high concentrations of the growth factor (Assoian et al, 1983). The TGF- $\beta$  concentration in platelets is 10-1,000 fold higher than that of other sources. TGF- $\beta$  is released from human platelets which have been degranulated by exposure to thrombin. The concentrations of thrombin required to release TGF- $\beta$  are identical to those concentrations that release the  $\alpha$ -granule marker  $\beta$ -thromboglobulin (Assoian and Sporn, 1986). Other cells types with established roles in inflammation and repair are sources of TGF- $\beta$ . These include lymphocytes (Kehrl et al, 1986) also macrophages. TGF- $\beta$  enhances wound healing *in vivo*. Wound chambers implanted subcutaneously in the back of rats show greater collagen deposition and fibroblast numbers after the addition of TGF (Sporn et al, 1983). TGF- $\beta$  can also reverse the effect of cancer chemotherapy-induced wound healing impairment, as judged by collagen and protein content, and cellular proliferation rate (Lawrence et al, 1986b). TGF- $\beta$  is more effective than EGF and PDGF in reversing repair wound healing, but the effect of TGF- $\beta$  could also be potentiated by the presence of PDGF and EGF.

TGF- $\beta$  has been detected and quantified in aqueous humour obtained at elective cataract surgery (Granstein et al, 1990; Jampel et al, 1990). A large percentage of this TGF- $\beta$  is in a latent form, which is not accessible to TGF- $\beta$  receptors and the isoform that is predominant in the aqueous is TGF- $\beta$ 2. Latent TGF- $\beta$  is not available to receptors. Activation of TGF- $\beta$  occurs in extreme cases of pH proteolytic activation with plasminogen and cathepsin-D (Lyons et al, 1988). These conditions may occur in the damaged area after glaucoma filtration surgery, and it is possible that latent TGF- $\beta$  is transformed to active TGF- $\beta$  after wounding.

Transforming growth factor- $\beta$  in the aqueous humour is probably synthesized within the eye, but it may also be derived from the serum (Connor et al, 1989; Knisely and Granstein, 1990). Jampel and colleagues (Jampel et al, 1990) measured levels at 2.3-8.1 ng/ml, with TGF- $\beta$ 2 being the predominant form and the majority being active. Ocular sources of TGF- $\beta$ 2 include the iris and ciliary body (Knisely and Granstein, 1990) as well as the vitreous humour (Connor et al, 1989). Some of the transforming factor- $\beta$  in aqueous may be derived from the posterior segment of the eye because

retinal pigment epithelial cells synthesize TGF- $\beta$  *in vitro* (Connor et al, 1988). Eyes with intraocular fibrosis in association with proliferative vitreoretinopathy contain mainly TGF- $\beta$ 2, rather than TGF- $\beta$ 1 (Connor et al, 1989).

TGF- $\beta$  in the aqueous humour is of a high enough concentration to have biological effect in ocular tissues. It is of interest that the anterior chamber of the eye is in an immunologically privileged site (Medawar, 1984). TGF- $\beta$  in the aqueous humour may contribute to this immuno suppressive environment by suppressing lymphocyte proliferation (Granstein et al, 1990). TGF- $\beta$  controls the expression of matrix metalloproteases, such as gelatinases, stromelysin and collagenase, by the fibroblast in the cornea (Girard et al, 1991). TGF- $\beta$  may be important in the wound healing response of Tenon's capsule fibroblasts after glaucoma filtration surgery.

Insulin-like Growth Factor: The insulin-like growth factors are polypeptide hormones with a MW of approximately 7,500. They share about 50% homology with pro-insulin, and they have insulin-like activity and therefore are called Insulin-like Growth Factors. They circulate in plasma in an inactive state bound to a large carrying protein and are recognised as the mediators of the growth promoting effects of growth hormones (Humbel, 1990). There are two forms called IGF-1, which is a basic peptide, and IGF-2, which is a neutral peptide. The insulin-like growth factors are anabolic hormones with wide ranging effects including cell replication, synthesis of glycogen, protein and glycosaminoglycans. They also transport glucose and amino acids across the cell membranes. There are high affinity receptors for the IGFs, which have been identified in many cell types, including fibroblasts and endothelial cells. Wound fluid contains a significant amount of IGF, which seems to be synthesized locally by fibroblasts as an autocrine regulator (Spencer et al, 1994). In adult fibroblast cultures, IGF stimulates DNA, RNA and protein synthesis, protein degradation and cell replication (Conover et al, 1985). It's mitogenic effect has been shown to be additive with EGF and PDGF in culture (Conover et al, 1986). The fact that fibroblast synthesized IGF requires PDGF for a maximum biologic response is consistent with the postulated role of IGF as a progression factor (see section on fibroblast proliferation). IGF seems to stimulate collagen synthesis by cultured fibroblasts. It has been suggested that this capability, and the ability to stimulate endothelial cells, make IGF a logical target for investigation in healing where there is excessive proliferation, such as in keloid formation.



Recent investigations have shown that the level of IGF-I in aqueous humour at cataract surgery was  $24 \pm 7$  mU/ml (SD). The level in diabetic patients was  $25 \pm 9$  mU/ml (SD) (Castro et al, 1990). The source of IGF-I in aqueous humour is unknown, but serum maybe the source (Tripathi et al, 1989). This is based on the observation that only members of the family of insulin-like growth factors or serum can stimulate differentiation of lens epithelium cells in chicken embryo's (Beebe et al, 1987). The lens differentiation factor lentropin may actually be closely related or even identical to IGF-I (Beebe et al, 1980; Beebe et al, 1987). The IGFs may be important in the growth and differentiation of lens epithelium *in vivo* (Danielpour et al, 1989; Basnett and Beebe, 1990). However, the other roles of IGF-I in aqueous humour are unknown.

Platelet Derived Growth Factor: The molecules known as platelet derived growth factor (PDGF) are dimers of A (17 kd) and B (16 Kd) chains (AA, AB and BB). As the name suggests, this growth factor is derived from platelets (Ross et al, 1974) and is localised to the  $\alpha$  granules (Kaplan et al, 1979). During the haemostatic response to injury, PDGF is released when degranulation occurs, either after exposure to thrombin or fibrillar collagen. Human blood monocytes, when activated by a variety of stimuli, release molecules similar to PDGF in biochemical and immunologic properties (Martinet et al, 1986). Cultured endothelial cells also secrete a PDGF like molecule, the release of which can be enhanced by treatment with thrombin (DiCorleto and Bowen-Pope, 1983). PDGF is a chemoattractant for inflammatory cells, including neutrophils and monocytes (Deuel et al, 1982b). Smooth muscle cells and fibroblasts are also attracted to low concentrations of PDGF (Seppa et al, 1982). PDGF is a mitogen in serum for cells of mesenchymal origin, including fibroblasts and smooth muscle cells (Deuel and Huang, 1983).

Platelets influence cellular migration into wounds by releasing PDGF. These are either membrane bound or secreted (Ross et al, 1986; Tzeng et al, 1984). These growth factors have direct chemotactic effects on connective tissue cells such as fibroblasts, due to high affinity PDGF-specific receptors on these cells (Ross et al, 1986). This chemotactic ability, shared by all cell types that secrete PDGF, draws connective tissue cells into the wound and promotes their proliferation (Ross et al, 1986). The levels of PDGF in aqueous have not been determined. Levels in the undisturbed aqueous would not be expected to be significant, but it is probable that levels would rise in conditions where blood entered the anterior chamber of the eye.

**Transferrin:** Transferrin is a iron binding glycoprotein with a MW of 79,550 that is found in serum and other body fluids (Parker and Bearn, 1962; Tripathi et al, 1989; Tripathi et al, 1989). Transferrin is essential for mitosis and maturation for a variety of cells (Weller et al, 1990), although it is not a classic growth factor. The concentration of transferrin in aqueous humour in the studies of one group ranged from 0.4 to 2.8 mg/dl (Inada et al, 1984; Inada et al, 1988). There are several isoforms of transferrin (Yu and Okamura, 1988; Tripathi et al, 1990b). Sources other than serum include the vitreous structures of the posterior segment of the eye, particularly retina, ciliary body and a few anterior segment structures (Yu and Okamura, 1988). Retinal capillary endothelium expresses the transferrin receptor and carrier system, therefore this could deliver the transferrin ion complex to the retina and vitreous, and then in the long term to the aqueous humour (Vadot et al, 1988). The vitreous humour contains large amounts ( $7.37 \pm 0.66$  ml/dl) of transferrin (Weller et al, 1990). The addition of insulin, transferrin and high density lipoproteins stimulate stromal fibroblasts to undergo cell division (Hyldahl, 1985). This mitogenic activity may also be a stimulatory factor to Tenon's capsule fibroblasts after glaucoma filtration surgery (Tripathi et al, 1989; Smyth et al, 1990). The number of receptors as the cells reach confluence decrease directly in proportion related to the proliferative activity of the cells (Weller et al, 1990).

**Interleukin-6:** Interleukin-6, which is also called B cell stimulating factor 2 (BSF-2), is a phosphoglycoprotein with a MW of 19,000-30,000, which evokes a variety of physiological and immunological response. This cytokine is made by a variety of cells, including monocytes, endothelial cells, activated T cells and fibroblasts (Mizel, 1989). IL-6 is probably present in small amounts (less than 10 units/ml) in aqueous humour from cataract patients, but there is an increase in its presence in Fuch's heterochromic cyclitis, uveitis and other conditions characterised by a disturbance of immunological control (Murray et al, 1990). The main role of IL-6 may be immunological control in the anterior segment of the eye (Hooks et al, 1988; Abi-Hanna et al, 1989).

**Fibronectin:** Fibronectin is a high molecular weight adhesive glycoprotein which is found in a soluble form in plasma and an insoluble form in tissues (Furcht, 1983; Yamada and Kennedy, 1985). Fibronectin exists as a protein with a MW of 440,000, which has two disulphide bonded units, with a MW of approximately 220,000 in size. Fibronectin is an extremely 'sticky' molecule in biological terms and is a very important component of many cell matrix interactions in the human body. It has multiple binding

sites which bind to a wide variety of substances, including type I-IV collagen, thrombospondin (Lahav et al, 1984), fibrin, dermatan and chondroitin sulphate, heparan and heparin sulphate proteoglycans (Ruoslahti et al, 1981). The cellular form of fibronectin binds hyaluronic acid (Yamada et al, 1980). Fibronectin also binds to the surface of fibroblasts, endothelium and macrophages (Hynes and Yamada, 1982; Furcht, 1983). The cellular adhesion of fibronectin to cells is mediated through a glycoprotein complex (Wylie et al, 1979; Damsky et al, 1985). There is a direct transmembrane link between fibronectin and the cell interior, and the integrins are the group of molecules which mediate this link. The sites of cell matrix adhesion can be identified ultrastructurally as regions of cell surface thickening adjacent to extracellular components. These adhesion sites contain the surface receptor complex, linking intracellular cytoskeletal elements to extracellular fibronectin (Heggeness et al, 1978; Kleinman et al, 1981). It is via these complex transmembrane structures that the extracellular matrix can exert influence on the cellular cytoskeleton. Inevitably, for a molecule with so many binding sites, fibronectin is known to play a role in cellular adhesion, migration, growth and differentiation (Ruoslahti, 1988). At wound healing sites, fibronectin is present in the matrix surrounding cells and on the cell surface. Cellular fibronectin is assembled into an insoluble matrix under and around matrix-secreting cells (McDonald, 1988). It may arise from local production by cells, as well as by deposition from plasma.

Fibronectin is secreted by a variety of cell types including fibroblasts, endothelium and macrophages (Bowersox and Sorgente, 1982; Tsukamoto et al, 1981; Aaberg, 1988). Production is increased in blood vessels after injury (Clark et al, 1982). It has been found to be a chemoattractant a variety of ocular cells, including Tenon's capsule fibroblasts (Joseph et al, 1987), trabecular meshwork cells (Calthorpe and Grierson, 1990) and corneal epithelial cells (Nishida et al, 1990; Nishida et al, 1983). The region inducing fibroblast chemotaxis has been localised to a specific 140 kD region of the fibronectin molecule (Postlethwaite et al, 1981). It has been detected in tears (Barlati et al, 1990), vitreous (Campochiaro et al, 1985) and bovine aqueous (Reid et al, 1982). Aqueous levels have been reported to fall after rabbit corneal injury (Kenney et al, 1986). Possible sites of production include the trabecular meshwork (Worthen and Cleveland, 1982), corneal endothelium and ciliary body (Tervo et al, 1986; Kohno et al, 1987) and fibronectin production has also been reported in epiretinal membranes (Hiscott et al, 1992). Fibronectin has also been found to have a synergistic effect with certain growth factors to produce scarring in the eye. The injection of growth factors alone into the vitreous does not cause scarring and retinal detachment but, if

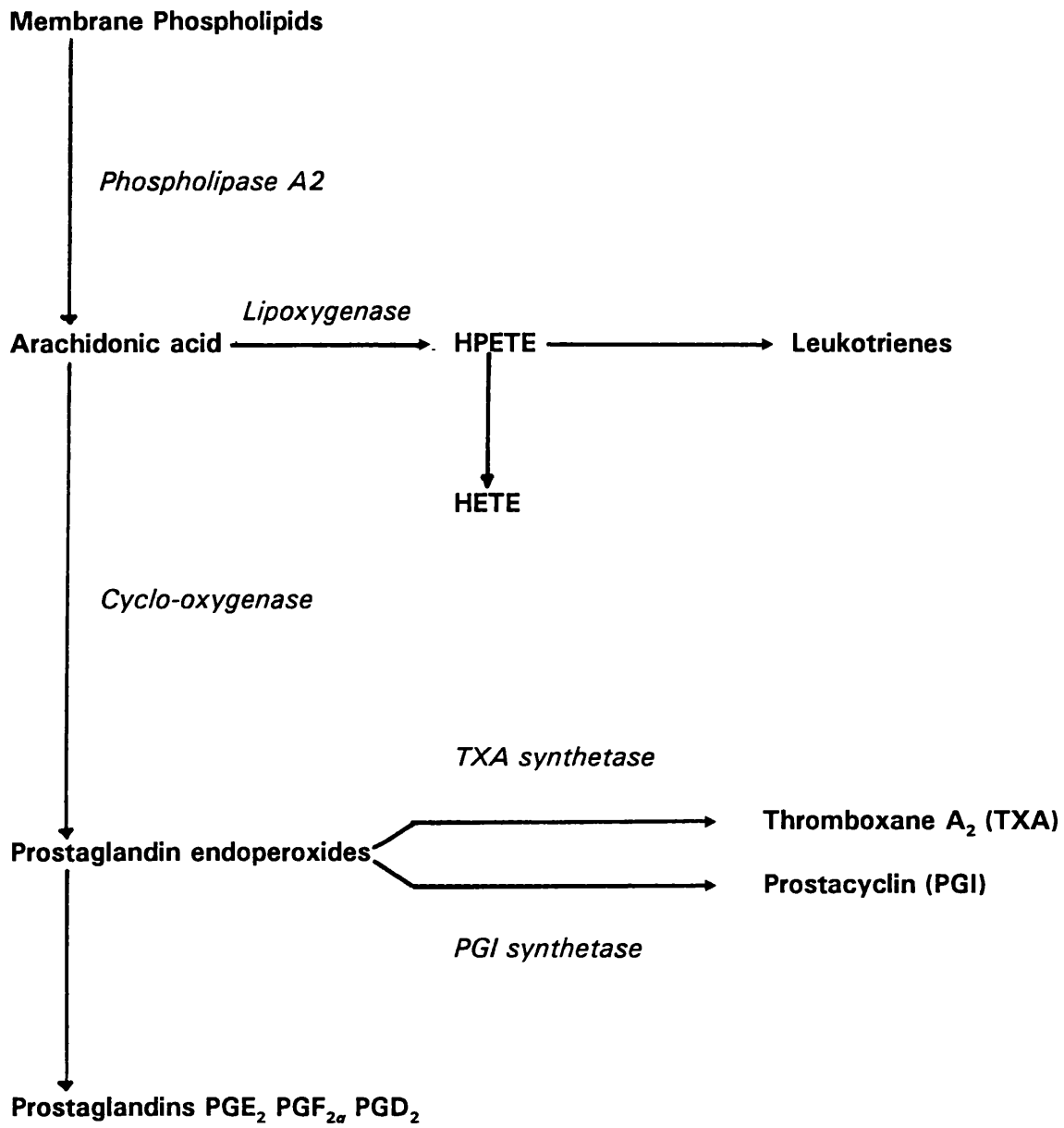
fibronectin is added to the mixture, then cicatricial retinal detachment results (Yeo et al, 1986). The stimulatory effect of fibronectin on fibroblasts is clear, but its role in aqueous humour is uncertain. It has been suggested that fibronectin may induce migration of trabecular meshwork cells out of the eye (Calthorpe and Grierson, 1990).

### **1.26 The role of inflammation and inflammatory cells**

Immediately after injury, intravascular components, plasma and blood proteins come into contact with tissue. There is an increase in vascular leakage due to secretion of local inflammatory mediators which include serotonin, kinins, histamine, prostaglandins, and leukotrienes (Boucek, 1984). Mast cells release histamine which induce contraction and separation of the endothelial cells, resulting in an increased blood vessel permeability (Majno et al, 1967). Serotonin causes arterial and venous contraction through its action on smooth muscles, while at the same time inducing arteriolar dilation (Boucek, 1984). Serotonin also increases permeability of the local blood vessels to plasma proteins (Boucek, 1984). The activation of Hageman factor (factor VII) results in kinin formation. Prostaglandins (PG) and leukotrienes are synthesized locally from the precursor arachidonic acid (AA), which is derived from polyunsaturated fatty acids and is released by the action of phospholipase A<sub>2</sub>. **(Figure 8)** AA is transformed into leukotrienes by lipoxygenase and prostaglandins by the cyclo-oxygenase enzymes. Lipoxygenase converts AA into unstable intermediate compounds, such as hydroperoxy-eicosatetraenoic acid (5-HPETE), which are converted into leukotrienes, such as B<sub>4</sub> (Samuelsson et al, 1978). Leukotrienes mediate many stages of inflammation and have a chemotactic effect on leucocytes (Palmer et al, 1980).

Many types of PGs that are produced by the cyclo-oxygenase enzyme and released into the injured tissue are influenced by other substances which accumulate in the wound, such as zinc (Zn), copper (Cu), glutathione and noradrenaline (Boucek, 1984). The most important of these products are prostacyclin, thromboxane A<sub>2</sub>, PGE<sub>2</sub>, PGF<sub>2 $\alpha$</sub> , and PGD<sub>2</sub>, and a variety of different physiological functions. PGE<sub>2</sub> dilates blood vessels and PGF<sub>2 $\alpha$</sub>  constricts vessels. Therefore, the prostaglandins act as vasodilators, they increasing vascular permeability and prolonging the inflammatory period. Components of the complement system, including C3a and C5a, increase vascular permeability mainly by causing histamine release from mast cells and platelets. C5a also activates the lipoxygenase pathway of AA metabolism in neutrophils and macrophages, which

Figure 8 Arachidonic acid metabolism



leads to the formation of additional mediators of increased permeability from these cells (Robbins et al, 1984).

Inflammatory cells are an integral part of wound healing. Polymorphonuclear cells and subsequently macrophages are stimulated to proliferate and migrate towards the site of damage by a variety of factors including complement derived peptides (Snyderman et al, 1970), products of the clotting system (Senior et al, 1986; Kay et al, 1974), the fibrinolysis pathway (Kaplan et al, 1973), the kallikrein-kinin system (Gallin and Kaplan, 1974) and transforming growth factor- $\beta$  (Wahl et al, 1987). The activated cells may then themselves release stimulatory factors. These factors may then stimulate other cells (Nathan, 1987) to proliferate, in particular fibroblasts and blood vessel endothelial cells (Polverini et al, 1977). Wounds depleted of macrophages show a marked delay in the onset and extent of granulation tissue (Leibovich and Ross, 1975). Inflammatory cells are a feature of the wound healing response in the failing bleb following experimental filtering surgery in the rabbit (Wahl et al, 1987) and the monkey (Jampel et al, 1987), although lymphocytes were not very prominent in the rabbit (Wahl et al, 1987).

There is some indirect evidence that larger numbers of inflammatory cells may be associated with increased rate of surgical failure after trabeculectomy in man. Conjunctival and Tenon's capsule biopsies were taken from two groups of patients at Moorfields Eye Hospital. One group had had primary surgery with no topical treatment and the second group had received at least two types of antiglaucoma topical medication for a minimum of a year. There was a significant increase in the number of macrophages, lymphocytes, mast cells and fibroblasts in the conjunctiva and Tenon's capsule of the treated group (Sherwood et al, 1989). At an average follow up of 28 months, the failure rate was only 2% in the primary treatment group with less inflammatory cells, against 21% in the medically treated group with more inflammatory cells (Lavin et al, 1990). However, there were also more fibroblast cells, so the exact role played by the increased number of inflammatory cells in the subsequent surgical failures is uncertain.

Biopsies of the conjunctiva and Tenon's capsule in eyes that had failed surgery within six months revealed a marked inflammatory infiltrate of macrophages and lymphocytes. In contrast, late failures (over nine months post surgery) showed only the occasional inflammatory cell (Hitchings and Grierson, 1983). A biopsy from a patient with raised intraocular pressure and a 'cyst of Tenons capsule', which developed several weeks after trabeculectomy, showed focal lymphocytic and associated fibroblast infiltration (van Buskirk, 1982).

## 1.27 The role of the fibroblast

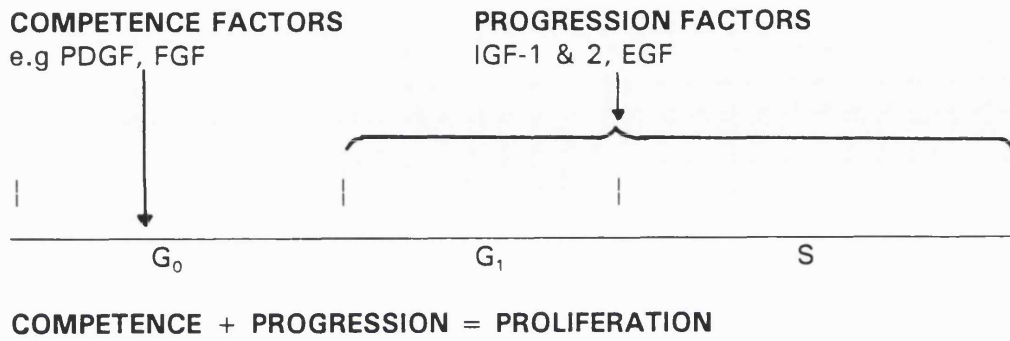
The fibroblast is the central cell in the whole process of wound healing. The role of the fibroblast has been arbitrarily subdivided into three aspects, proliferation, migration and synthesis, although all these functions occur simultaneously in the *in vivo* situation. Fibroblasts are the main producers of extracellular matrix proteins in scar and scar-like tissue, and are also the major mediators of scar contraction. Without the fibroblast cell, there would be no significant scar tissue in most body tissues.

**Fibroblast proliferation:** Fibroblasts are stimulated to migrate towards the damaged area and proliferate. Many factors are known to have stimulatory effects on fibroblasts. The effects of these factors are complicated and some growth factors have been shown to have a stimulatory or inhibitory effect on fibroblasts depending on the cells and conditions (Roberts et al, 1985b). The stimulation to proliferate in fibroblasts by various growth factors is associated with markedly increased transcription of proto-oncogenes (Cochran et al, 1984). High levels of expression of these genes are associated with cell proliferation or tumourigenicity.

To proliferate, cells have to go through stages where they have to become competent to divide, and they then have to be stimulated by progression factors. Certain growth factors have been characterised as either competence or progression factors on the basis of the stage in the cell cycle in which they act (Pledger et al, 1977) (**Figure 9**). Competence factors act early in the cycle, moving the cells out of the resting stage. Progression factors act later. PDGF, FGF and calcium phosphate are typical competence factors while IGF-1, IGF-2 and EGF are progression factors. Such growth factors have very different activities, but can show strong synergistic activity in promoting cell division. The IGF progression factors alone will not induce cells to proliferate, while PDGF at high doses can induce proliferation, possibly by inducing the production of IGF itself (Clemons et al, 1981). Certain growth factors may make the cell competent by acting early in the cell cycle elevating cytoplasmic calcium and the pH of certain early genes such as *fos* and *myc*.

*In vitro*, an exponentially growing population of fibroblasts goes through cell division every 8-20 hours on average. The cell cycle is divided into several phases with boundaries provided by the two most easily observed events, DNA synthesis (S phase) and mitosis (M). The remainder of the cycle consists of two relatively undefined time gaps which are G<sub>1</sub>, the time between mitosis and the onset of DNA synthesis, and G<sub>2</sub>,

Figure 9 Competence and progression factors



Competence  
myc, fos expressed  
phosphatidylinositol  
pathway  
activated  
cytoplasmic pH &  
Ca<sup>2</sup> increased

Progression  
DNA Synthesis



the time between S phase and mitosis (Baserga, 1985). Cellular DNA is replicated during an interval of the cell cycle, the S phase. Protein synthesis occurs during S phase and is required for DNA synthesis. At the onset of S phase, a substantial increase occurs in most of the enzymes involved in DNA synthesis and metabolism, including polymerases, ligases and thymidylate synthetase, as well as the histones and ribonucleotide reductases. During the mitotic phase, which lasts 30 minutes to an hour, protein synthesis is substantially decreased and RNA synthesis ceases entirely. During the course of each cell cycle, the cell doubles its mass in preparation for division. The G<sub>1</sub> and G<sub>2</sub> phases are characterised by active RNA and protein synthesis. The products of this synthetic activity contribute to the doubling of cell mass. Although the average cell time cycle varies with different cell types, the composite length of S, G<sub>2</sub> and M phases is a consistent 10 to 12 hours. The concepts of competence factors and progression factors are important. Fibroblasts may remain in a reversible quiescent stage when there is a constant supply of the progression factors present in plasma in concentrations sufficient to support cell growth. The transition to cell replication and proliferation may be initiated by a single stimulus - the release of competence factors - conferring the ability to proliferate in the presence of plasma. This mode of regulation probably allows for the specific stimulation of cell proliferation in areas of tissue in injury by the localised release of competence factor by cells such as platelets, mononuclear phagocytes and lymphocytes at the damaged area (Morgan and Pledger, 1992).

Fibroblasts make a relatively late appearance at sites of wound healing and reach optimal numbers within one to two weeks (Ross and Odland, 1968). Miller et al found only a few fibroblasts three days after filtration surgery in the rabbit, but there were considerable numbers by day 10 (Miller et al, 1989). They were particularly prominent at the border of the bleb, especially around the extraocular muscles. Regan found little sign of fibroblasts in the monkey model of filtration surgery in the first week in eyes treated with intense cautery. However, proliferation was very apparent from two weeks onwards. She found however, that fibroblastic proliferation and neovascularisation were present at the end of one week, if cautery was not sufficient to affect the limbal structures (Regan, 1963). Another study on monkeys found fibroblast proliferation became prominent at day five after posterior lip sclerostomy filtration surgery. Between days 8 and 14, they lined the sclerostomy and proliferated to occlude the fistula. As the healing response slowly regressed, the numbers of fibroblasts then slowly returned to a normal density, presumably by a process of programmed cell death. Inevitably, the main impetus for control of fibroblasts after

glaucoma filtration surgery has concentrated in the area of inhibition of fibroblast proliferation on the simplistic basis that, if the cells were not able to proliferate, then insufficient numbers would be present to carry out the processes of scar formation.

Fibroblast migration: Cellular migration within an organism plays an important role in its embryonic development and its response to injury and infection. These events are controlled and mediated to a great degree by specific polypeptides which act as chemoattractants, through the process of chemotaxis. Chemotaxis is defined as the directed migration of cells in response to a concentration gradient of a soluble attractant (McCarthy et al 1988 book chapter, p 281-319). During chemotaxis, cells move in the direction of an increased concentration of that factor. Zigmond and Hirsch defined two components of migration, which are a) a direct migration where cells moved up a positive concentration gradient which they call chemotaxis, and b) an increased random migration where the cells move independent of a concentration gradient which they term chemokinesis (Zigmond and Hirsch, 1973). Cells orient in response to gradients of chemotaxis substances with a leading front (lamellipodium) extending towards the source of the chemoattractant.

A variety of cells involved in wound healing processes migrate towards chemoattractants. These cells include macrophages and polymorphonuclear cells, smooth muscle cells, endothelial cells and fibroblasts. The presence of cell surface receptors for a factor is required for cells to respond, and these receptors also determine the specificity of response. A lack of chemotactic factors for fibroblasts and other cells involved in tissue repair may reduce the rate of repair. On the other hand, overproduction may result in excessive scarring.

A variety of substances have been shown to promote the migration of fibroblasts *in vitro* and may contribute to the repetitive phase of healing. These include complement components (Postlethwaite et al, 1979), platelet-derived growth factor (PDGF) released by platelets when they aggregate (Grotendorst et al, 1981; Seppa et al, 1982), transforming growth factor- $\beta$  (Postlethwaite et al, 1987), damaged collagen (Postlethwaite et al, 1978), elastin (Senior et al, 1984; Senior et al, 1982), inflammatory cell products (Postlethwaite et al, 1976; Sobel and Gallin, 1979; Postlethwaite and Kang, 1980), fibronectin (Joseph et al, 1987; Postlethwaite et al, 1981; Mensing et al, 1983) and fibrinogen derivatives (Senior et al, 1986).

Molecules such as fibronectin bind to many macromolecules, including collagen, thrombospondin, heparin, glycosaminoglycans, fibrin and cell-surface receptors on

fibroblasts and other cells (McDonald, 1988). Adhesion is receptor mediated via cell-surface receptor molecules of the integrin family. These molecules contains a specific domain which has cell-adhesive activity. The surface receptor complex, linking intracellular cytoskeletal elements to extracellular fibronectin (Heggeness et al, 1978; Kleinman et al, 1981; Buck and Horwitz, 1987). It is via these complex transmembrane structures that the extracellular matrix can exert influence on the cellular cytoskeleton.

Other factors may play a role in stimulating fibroblast motility. Fibroblasts also have got to penetrate and move through the extra cellular matrix. Enzymes include plasmin, plasminogen activator and collagenase. Space clearing can also be achieved by phagocytosis (Saba and Jaffe, 1980). The extra cellular matrix produced by fibroblasts could actually serve to exert pressure on the spaces within the matrix (Repesh et al, 1982; Toole, 1981). Fibroblasts have to migrate towards sites of healing. The movements of cells may, in itself, cause traction and wound contraction (Harris et al, 1980; Harris et al, 1981). Spindle-shaped fibroblasts with masses of microfilaments (myofibroblasts) are also thought to play a major role in the contraction of newly forming scars (Montandon et al, 1973). These cells are prominent in animal models of filtering surgery (Miller et al, 1989; Peiffer et al, 1981). There were also abundant spindle-shaped fibroblasts in biopsies of failing blebs taken within 6 months of surgery (Hitchings and Grierson, 1983).

Fibroblast extracellular matrix synthesis and modelling: Fibroblasts secrete fibronectin, glycosaminoglycans and tropocollagen, which then cross-link to form collagen. The collagen molecule is composed of three polypeptide chains arranged in a right-handed triple helix. Each polypeptide chain is translated from messenger RNA on membrane-bound ribosomes and released into the rough endoplasmic reticulum (RER) (Gabbiani and Montandon, 1977). In the RER, certain proline and lysine residues are hydroxylated by proline and lysine hydroxylases respectively, using  $Fe^{2+}$  and ascorbate as catalysts (Rhoeds and Udenfriend, 1970; Prockop et al, 1966). Subsequently, three helical polypeptide molecules are brought together to form a procollagen molecule (Gabbiani and Montandon, 1977). Procollagen is then transported to the Golgi complex where, after modifications, it is secreted into the extracellular space by microtubules and microfilaments (Dehm and Prockop, 1972; Jimenez et al, 1971). In the extracellular space, procollagen peptides lose the  $NH_2$  and  $COOH$  terminal domains of the molecule, forming the collagen precursor tropocollagen (Gabbiani and Montandon, 1977). Lysyl oxidase is the enzyme involved in the cross-linking of the tropocollagen molecules, with copper as an essential component (Chvapil and Koopmann, 1984). The degree of

cross-linking, not the amount of collagen deposited, determines the strength of a healed tissue (Chvapil and Koopmann, 1984).

Type III collagen, associated with embryonic tissues, is the first type of collagen to fill the adult wound (Guber and Ross, 1978; Gabbiani et al, 1976). It is deposited initially in intimate association with pre-existing fibrin networks and is stabilized by mucopolysaccharides (Ross, 1968). Type III is replaced by Type I collagen, the mature form, after the fibroblasts and endothelial cells of the blood vessels regress from the granulation tissue (Dvorak, 1986). Collagen is a major component of the wound matrix and is a prominent feature of experimental filtering surgery failure in the rabbit and monkey (Miller et al, 1989; Desjardins et al, 1986). Many fibroblasts in the failing blebs of rabbits were found to have cytoplasm rich in endoplasmic reticulum, with some distended cisternae. This appearance is consistent with an actively metabolizing cell undergoing transcription (Miller et al, 1989). The exact pattern of this collagen secretion in the *in vivo* situation is not known, but methods are now available to study this in animal models using collagen mRNA in situ hybridization (Katakami et al, 1990). Collagen accumulation is also a prominent feature of failing blebs in man (Hitchings and Grierson, 1983). In a histological review of four failed filtration blebs, the area of collagenous connective tissue beneath the bleb was thicker than usual throughout the bleb wall. However, the collagen fibrils themselves had a normal appearance and banding pattern. In addition, no abnormal accumulation of extracellular material was found in the failed blebs (Addicks et al, 1983).

The fibroblasts remodel the scar tissue and become orientated with the corneoscleral lamellae. This is found in the monkey (Desjardins et al, 1986) and rabbit (Miller et al, 1989) models of filtering surgery. Remodelling of the scar matrix continues for several months after injury (Peacock, 1984), resulting in a hypocellular fibrous tissue which may result in an impermeable capsule. This fibrous tissue consists of irregular bundles of collagen and was found to be a feature of blebs that failed late (more than nine months after surgery) (Hitchings and Grierson, 1983). It is interesting that there were histologically normal lymphatics in the tissue beyond the fibrous capsule. The basic physiology of fluid flow through the conjunctival and subconjunctival extracellular matrix is still not understood.

The factors regulating collagen production occur in different phases of the wound healing process. In the early stage after damage, factors released from platelets during clotting play a key role in regulating collagen. One factor is platelet-derived growth factors (PDGF) (Knighton et al, 1982). This growth factor recruits connective tissues

cells into the wound through its chemotactic activity (Seppa et al, 1982) and also stimulates proliferation of these cells (Rutherford and Ross, 1976). PDGF also enhances connective tissue deposition (Grotendorst et al, 1985). Collagen deposition in subcutaneous chambers in rats with diabetes exhibit low levels of collagen deposition, which can be increased by the addition of PDGF.

TGF- $\beta$  also enhances the rate of connective tissue deposition in the rat (Sporn et al, 1983; Lawrence et al, 1986b). This even occurs when wound healing is impaired by systemic anti-cancer treatment such as adriamycin (Lawrence et al, 1986b). In combination with other growth factors such as PDGF and EGF, there is an enhanced effect. There is also good tissue culture evidence that low levels of TGF- $\beta$  significantly increased the rate of new collagen synthesis in fibroblasts (Ignatz and Massague, 1986; Roberts et al, 1986). In the middle phase of wound healing, macrophages play a major role in the stimulation of extracellular matrix deposition. Macrophages release growth factor activity like PDGF (Shimokado et al, 1985), FGF (Baird et al, 1985) and TGF- $\beta$  (Assoian et al, 1987).

Collagen degradation occurs throughout the process and increases as the wound matures (Zeitz et al, 1978). The enzyme collagenase, which is a matrix metalloproteinase synthesised by fibroblast epithelial cells and macrophages, is a primary mediator of collagen turnover.

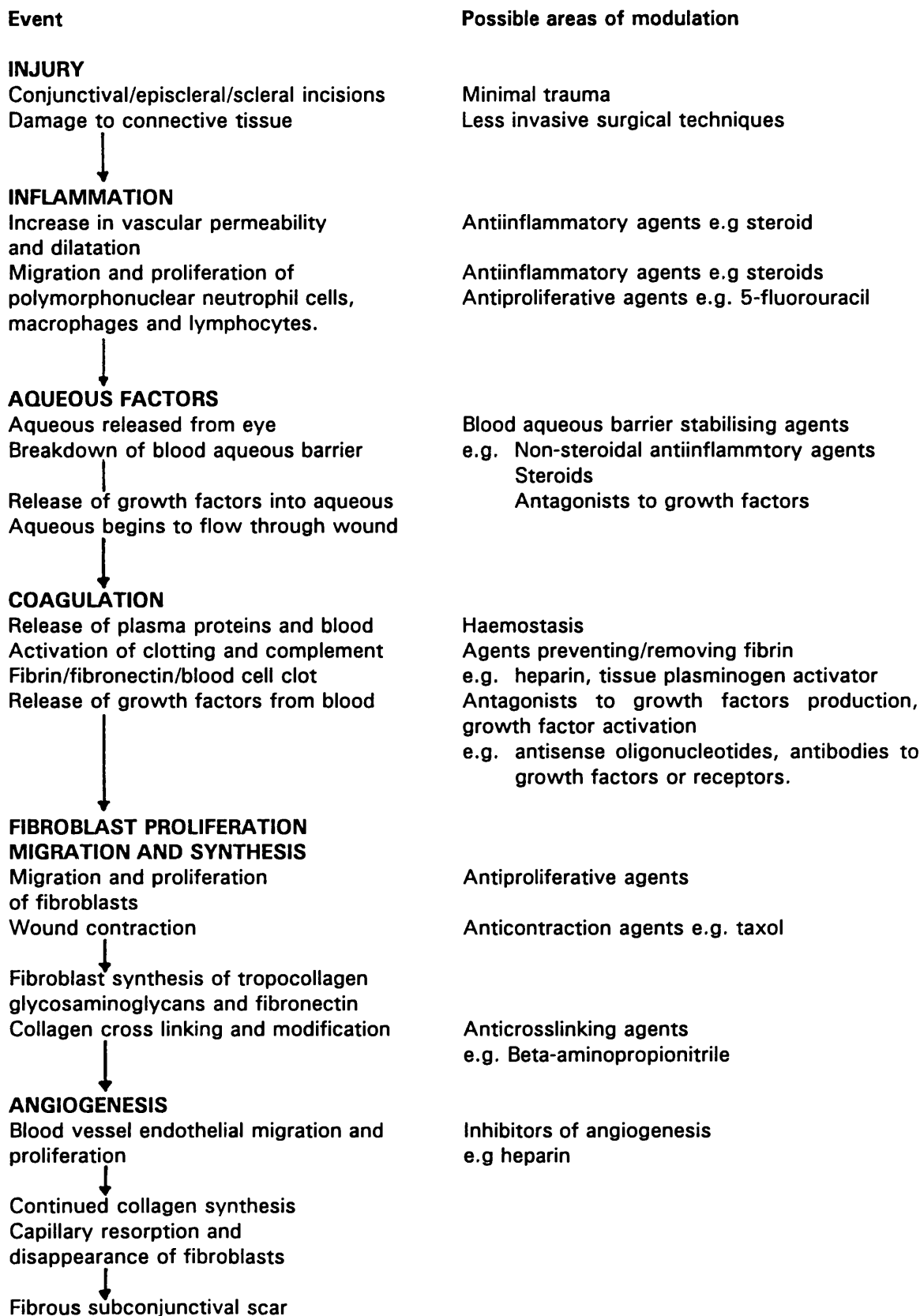
### **1.3 Modulation of healing after glaucoma filtration surgery**

The wound healing processes after glaucoma filtration surgery can be modulated at many stages of the process (**Figure 10**). As before, these agents have been divided into anti-inflammatory, thrombolytic, anti-proliferative, anti-contractile and anti-collagen cross linking agents, although there may be an overlap of actions.

#### **1.31 Anti-inflammatory agents**

Inflammation is a dual process, involving both an increase in vascular permeability and the migration of inflammatory cells into the injured area. Modulating agents may change the vascular response to injury by reducing blood vessel dilation, permeability, cellular infiltration and the deposition of fibrin. All these events are dependent factors including histamines and prostaglandins (Eakins, 1977), which are released into

**Figure 10** Sequence of events in wound healing and potential areas of modification after glaucoma filtering surgery (simplified, events and agents have overlapping time duration and action)



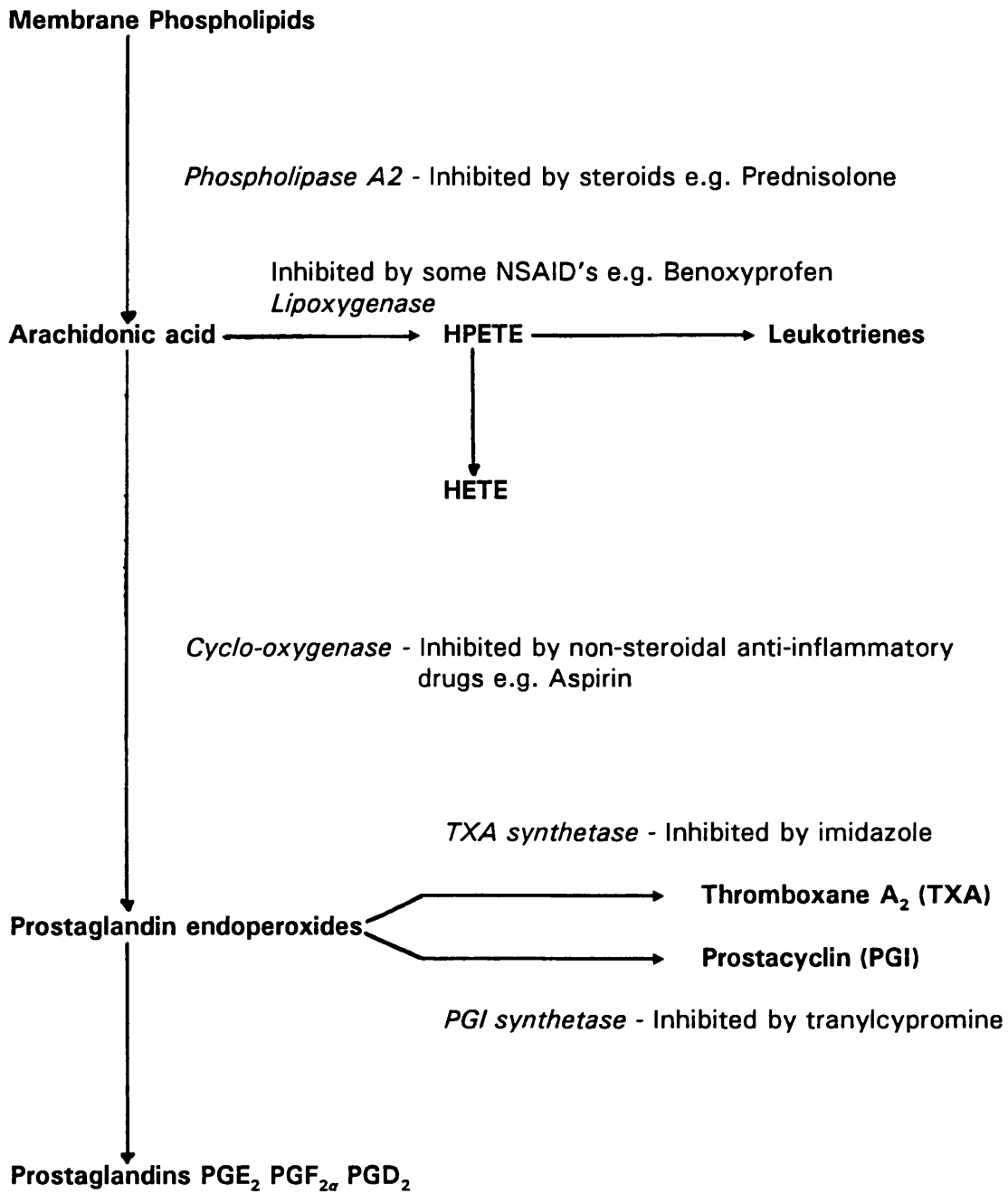
wounded tissue. The prostaglandin system is particularly important in ocular tissue because there is a relative lack of prostaglandin degradation pathways in the eye (Eakins et al, 1974). Therefore, prostaglandins may accumulate in the aqueous humour and prolong the inflammatory process.

**Non-steroidal Anti-Inflammatory Drugs (NSAID):** Most non-steroidal drugs have similar actions to aspirin. These agents are superior to steroids in inhibiting the prostaglandin or leukotriene synthesis from arachidonic acid. The common action of these inhibitory drugs, such as aspirin and indomethacin, is inhibition of the cyclooxygenase pathway (Flower and Vane, 1974; Nozu, 1978) (Figure 11). However, more arachidonic acid is diverted to the lipoxygenase pathway, increasing the amount of leukotriene. This makes conventional non-steroidal drugs less effective than steroids in inhibiting inflammation, although other non-steroidal anti-inflammatory drugs may have a wider spectrum of anti-inflammatory activity and may be able to inhibit both lipoxygenase and cyclo-oxygenase pathways (Kulkarni and Eakins, 1976; Moncada et al, 1977; Allan et al, 1980; Moncada et al, 1976). There are also specific inhibitors of the phospholipase A<sub>2</sub> enzyme and the lipoxygenase enzyme (Parker, 1982). Prostacyclin formation (Bunting et al, 1976) and thromboxane synthesis (Kulkarni and Eakins, 1976; Moncada et al, 1977; Allan et al, 1980; Moncada et al, 1976).

In the eye, topical administration of non-steroidal cyclo-oxygenase inhibitors reduces signs of intraocular inflammation, such as increase in the amount of aqueous humour protein, increased prostaglandin release into the aqueous humour and iris hyperaemia. However, cyclo-oxygenase inhibitors may also potentiate the migration of the white cells into the aqueous humour (Kulkarni et al, 1981), via increased leukotriene-mediated chemotaxis (Higgs et al, 1979). Phospholipase A<sub>2</sub> inhibitors that retard both lipoxygenase and cyclo-oxygenase pathways have a similar anti-inflammatory spectrum, as well as inhibiting white cell migration into the aqueous humour.

Non-steroidal anti-inflammatory agents, such as indomethacin 0.5%, have also been used after filtering surgery but did not appear to influence the long term results and, in fact, seemed to cause more macroscopic inflammation (Migdal and Hitchings, 1983). These groups of drugs may also have direct effects on fibroblast proliferation (Blumenkranz et al, 1984a). Some agents used to prolong drug delivery may in themselves excite an inflammatory reaction, although this did not apparently accelerate bleb failure in an animal model (Kay et al, 1986). Although the anti-metabolite 5-fluorouracil has been used primarily to suppress fibroblast proliferation, it is possible

**Figure 11** Arachidonic acid metabolism and points of inhibition





that antiproliferative and other drugs may exert some of their effects by inhibiting inflammatory cells. In one study of conjunctival wound healing, the inflammatory reaction was least marked in rabbits treated with subconjunctival doxorubicin (Ren et al, 1989). In the original study of 5-fluorouracil in filtering surgery in monkeys, the treated eyes were noted to have noticeably less conjunctival injection (Gressel et al, 1984).

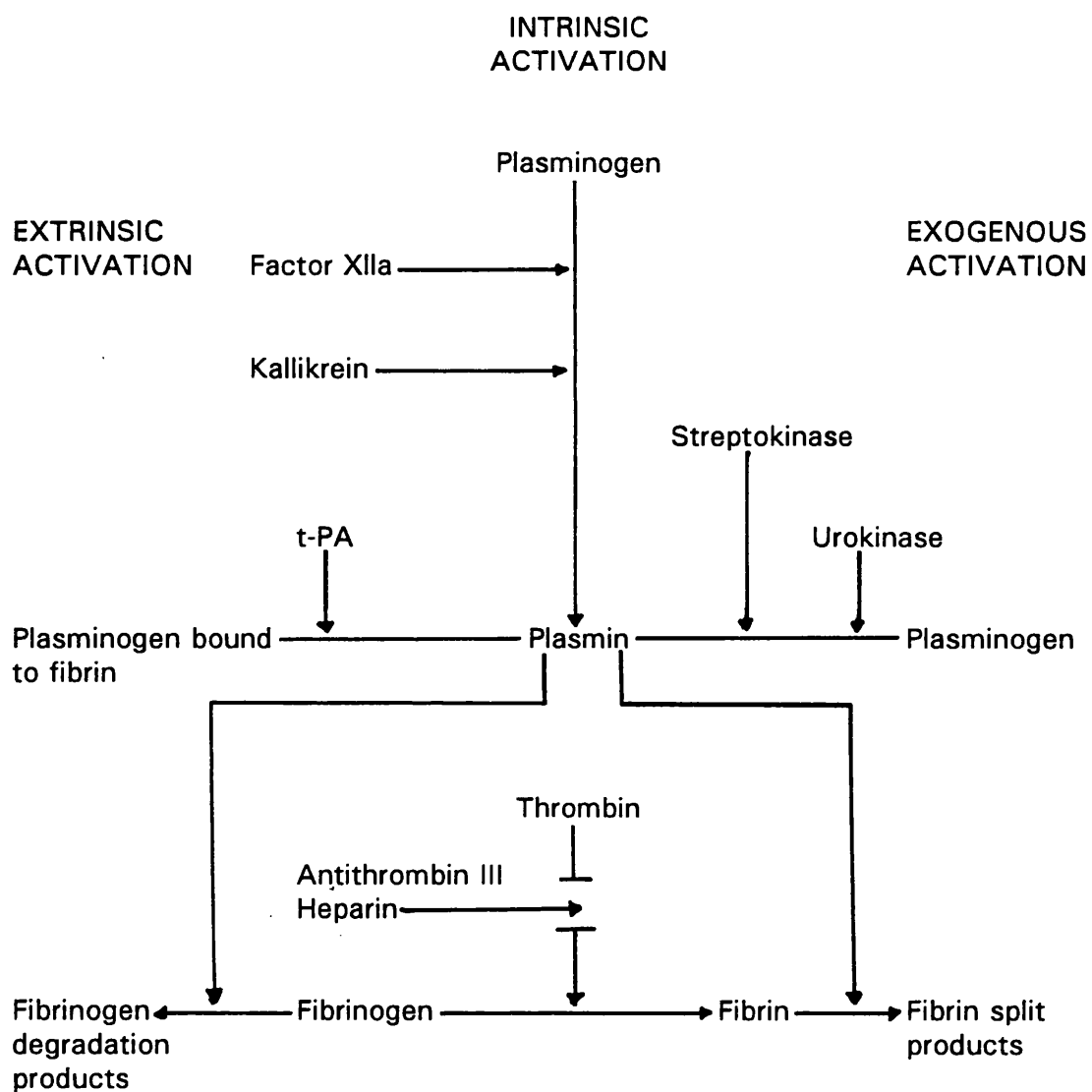
**Steroidal Agents:** Steroids inhibit the enzyme phospholipase A<sub>2</sub> which mediates the release of prostaglandins and the interleukin precursor arachidonic acid from the cell membrane (Flower and Blackwell, 1979; Hirata et al, 1980). Steroids prevent the synthesis of inflammatory mediators, acting on both the lipoxygenase and cyclooxygenase pathways (**Figure 11**). Other anti-inflammatory actions of steroids include inhibition of granulocytes (Long, 1957) and mast cell degranulation (Santamaria, 1983), intracellular lysosomal stabilization (Liddle, 1961), reduction of chemotaxis and vascular permeability, and suppression of lymphocyte maturation (Ketchel et al, 1958).

Topical ocular steroids reduce intraocular inflammation by reducing aqueous humour protein from the breakdown of the blood-aqueous barrier, hyperaemia of the anterior uvea, and leucocyte migration into the aqueous humour (Kulkarni et al, 1981). Because steroids influence the inflammatory response, they are used routinely after many types of ocular surgery including filtration surgery. Eyes in rabbits treated with topical steroids showed a reduction in inflammatory cells and an increase in bleb survival time (McGuigan et al, 1986; Miller et al, 1989). Starita and colleagues showed that there was a higher success rate after filtration surgery if topical steroids were used, and that the final intraocular pressure was lower, even if only the successes in the steroid treatment and no steroid treatment group were compared (Starita et al, 1985). However, like other drugs, steroids also have an effect on other cellular functions, including for instance, fibroblast proliferation. Proliferation is stimulated at low doses but inhibition at higher doses (Blumenkranz et al, 1984a).

### **1.32 Thrombolytic agents**

Fibrin is a prominent component of filtration surgery in animals and man (see previous section). Agents which inhibit the formation of fibrin or facilitate its breakdown are potentially useful in the modulation of wound healing after filtration surgery (**Figure 12**). Heparin, which is a sulphated glycosaminoglycan, is found in mast

**Figure 12 Extrinsic, Intrinsic, and Exogenous Activation of Plasmin.**



cells near the walls of blood vessels and on the surface of endothelial cells. It acts as an anticoagulant by increasing the rate of formation of irreversible complexes between antithrombin III, other clotting factors including antitrypsin and antithrombin III (Davie, 1986). It also binds to a number of extracellular matrix components, to several growth factors and interferes with cell-to-substrate attachment (Blumenkranz et al, 1992).

Heparin has been found to have an inhibitory effect on growth factor-induced proliferation and chemotaxis in cultured human ocular retinal pigment epithelial cells (Leschey et al, 1991). Heparin has also been shown to reduce the rate of cell induced collagen gel contraction, possibly by an effect on cytoskeletal components (Ehrlich et al, 1986). However, the use of intraocular heparin has been tempered by the fear of inducing intraocular haemorrhage and there is some clinical evidence that this may be the case (Johnson and Blankenship, 1988).

Plasmin, which is derived from the proteolytic activation of plasminogen, hydrolyses peptide bonds in the fibrin network. Therefore, activators of endogenous plasminogen promote the dissolution of fibrin. Urokinase and streptokinase are two exogenous plasminogen activators that are used in the treatment of vitreous haemorrhage (Snyder et al, 1987; Chapman-Smith and Crock, 1977) and hyphaema (Friedman, 1952; Leet, 1977). Urokinase is a trypsin-like serine protease (White et al, 1960), present in the serum as a proenzyme (pro-urokinase), that has full thrombolytic capability in human serum by native competitive inhibitors (Zamarron et al, 1985). When fibrin is formed, these inhibitors are in turn inhibited, promoting pro-urokinase activation (Lijnen et al, 1985). Plasmin itself is also an effective prourokinase activator. Urokinase used in the eye can, however, be associated with local inflammation and toxicity. Streptokinase is also a potent activator of plasminogen. It forms a complex with plasminogen, after which an active site is produced which is similar to the active site in active plasmin (Kosow, 1975). However, streptokinase is not widely used because of its immunogenic character (Johnson and McCarthy, 1959).

Tissue-type plasminogen activator (t-PA) is a naturally occurring trypsin-like serine protease that has received the most clinical attention. t-PA has a very specific affinity for a fibrin clot (Dano et al, 1985). Plasma t-PA normally exists as an inactive proenzyme, but during clot formation and in the presence of fibrin, the affinity of t-PA for plasminogen increases (Hoylaerts et al, 1982). This allows plasminogen activation on the fibrin clot without significant plasminogen conversion by t-PA elsewhere (Rijken et al, 1982). T-pa forms a complex with fibrin and fibrinogen, leading to conversion of inactive plasminogen into active plasmin, which then degrades fibrin into soluble

peptides. Plasmin is usually inhibited by anti-plasmin factors in the plasma. This is prevented by the fibrin/t-PA/plasmin complex which is sequestered within the clot and allows the thrombolytic process to continue until all of the fibrin is lysed (Verstraete and Collen, 1986). The disadvantage of lysing fibrin may be that the products may be chemotactic for cells that stimulate the healing process (Kaplan et al, 1973; Gallin and Kaplan, 1974).

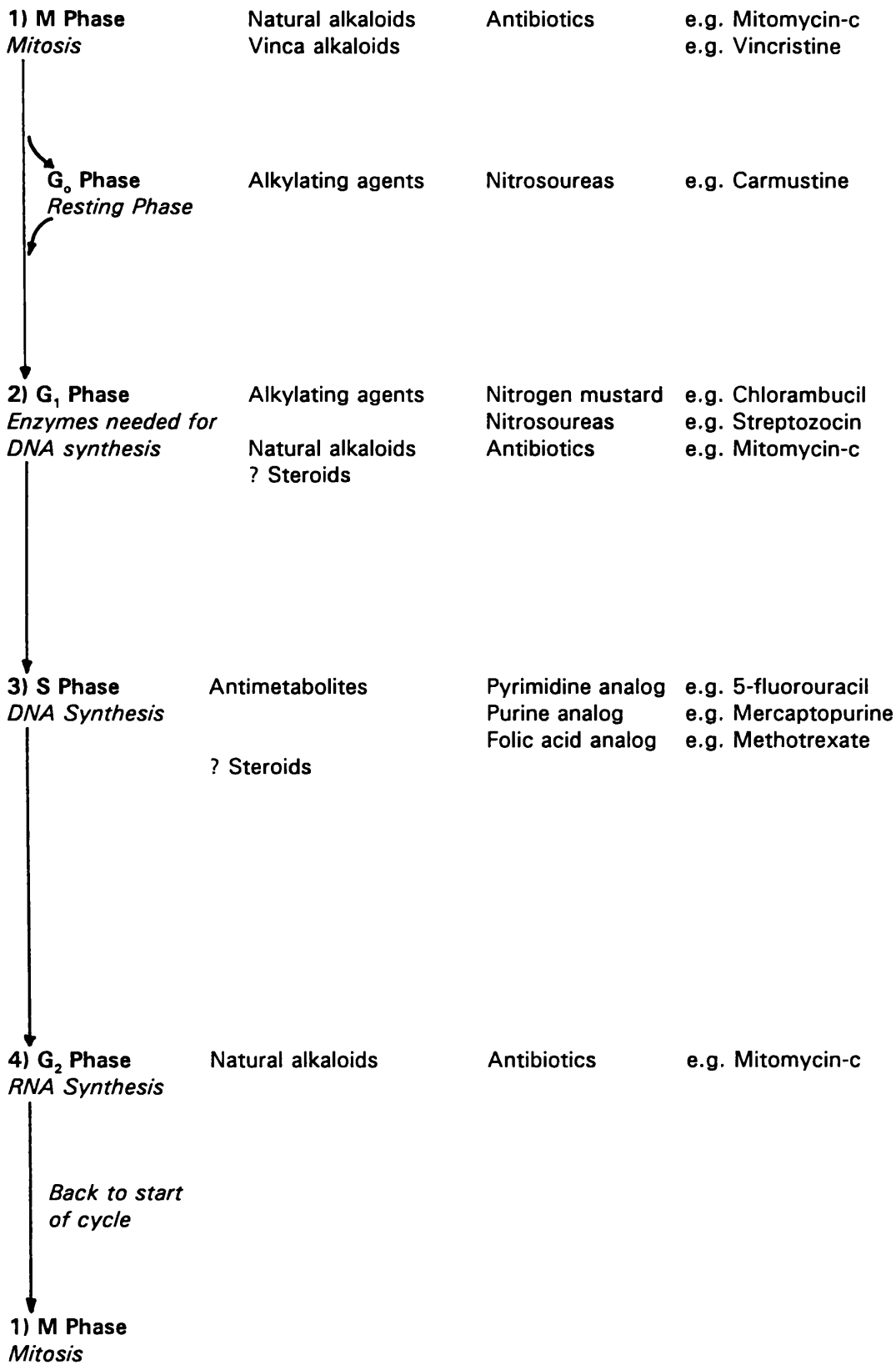
Intraocular use has shown that t-PA may be associated with some changes in corneal thickness, but overt toxicity at therapeutic doses seems to be minimal (Snyder et al, 1987; Jaffe et al, 1989; Williams et al, 1988). Studies of subconjunctival tissue plasminogen activator in rabbits after filtering surgery have shown delayed bleb failure in the treated group (Strauss et al, 1990). Plasminogen activator has also been reported to dissolve a blood clot that had been obstructing a filtering bleb (Ortiz et al, 1988).

### **1.33 Anti-proliferative agents**

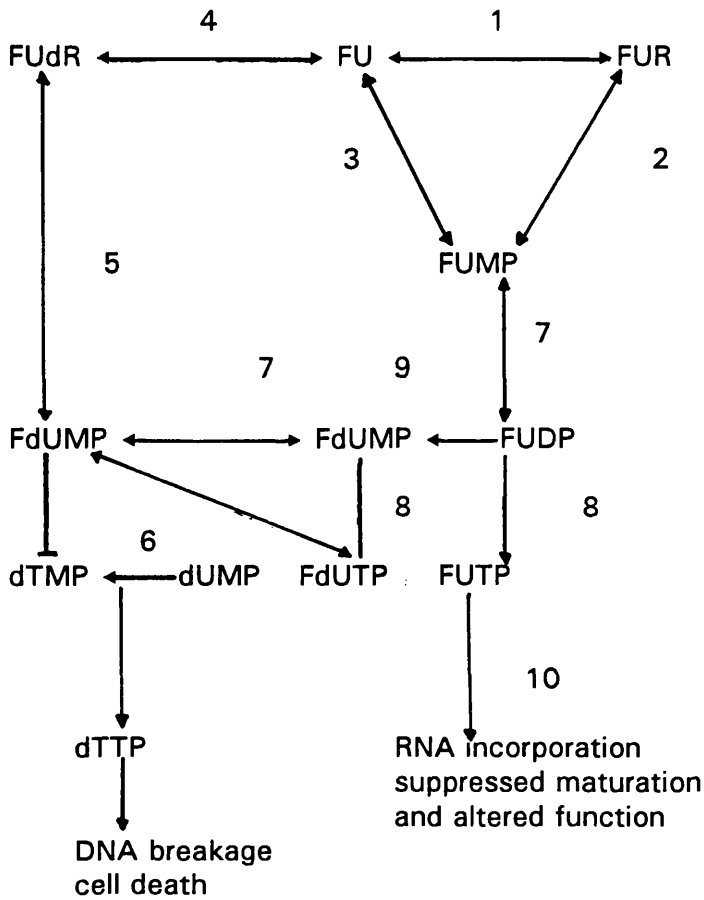
Wounding in the skin or the eye is normally associated with the rapid proliferation of the cells in the area including fibroblasts (Im and Hoopes, 1970). The failure of glaucoma filtration surgery due to scarring arises because of fibrocellular proliferation and the laying down of newly formed collagen by fibroblasts and myofibroblasts (Machemer, 1977). Other agents, such as steroids and non-steroidal antiinflammatory drugs, may also inhibit fibroblast proliferation and the healing process (Priestley, 1978; Ehrlich and Hunt, 1969; Laval and Coles, 1953; Hial and DeMello, 1977; Neupert and Muller, 1975). However, much attention has concentrated on agents that inhibit proliferation, to inhibit the scarring process (Blumenkranz et al, 1984b). Antiproliferative drugs can be arbitrarily divided into groups according to their chemical nature and mode of action and these groups include antimetabolic drugs, natural alkaloids, alkylating agents, and differentiating agents. The agents act in different phases of the cell cycle (**Figure 13 and 14**).

Antimetabolic agents: Antimetabolic drugs are one of the groups of chemotherapeutic agents that are used clinically to control cellular proliferation. They are structural analogs to metabolically active molecules, among which are purines, pyrimidines and folic acid. Antimetabolites primarily interfere with DNA/RNA synthesis (Blumenkranz et al, 1984b) or usage, eventually disrupting cellular function. Reduction of inflammation and scar formation are secondary to these actions (Molteno et al, 1976).

**Figure 13 Cell cycle and the effects of antineoplastic agents**



**Figure 14 Biochemical mechanism of action of fluoropyrimidine (adapted from Lee et al, 1991)**



**Enzymes**

- 1 Uridine phosphorylase
- 2 Uridine kinase
- 3 Phosphoribosyl transferase
- 4 Thymidine phosphorylase
- 5 Thymidine kinase
- 6 Thymidylate synthetase
- 7 Pyrimidine monophosphate kinase
- 8 Pyrimidine diphosphate kinase
- 9 Ribonucleotide reductase
- 10 RNA polymerase

**Substrate Products**

- |       |                                     |
|-------|-------------------------------------|
| FUR   | 5-fluorouridine                     |
| FUMP  | 5-fluoro-5 monophosphate            |
| FUdR  | 5-fluoro-2 deoxyuridine             |
| FdUMP | 5-fluoro-2deoxy-5 monophosphate     |
| FUDP  | 5-fluorouridine-5 diphosphate       |
| FUTP  | 5-fluorouridine-5 triphosphate      |
| FdUDP | 5-fluorodeoxyuridine-5 diphosphate  |
| FdUTP | 5-fluorodeoxyuridine-5 triphosphate |
| dUMP  | Deoxyuridine-5 monophosphate        |
| dTMP  | Deoxythymidine-5 monophosphate      |
| dTTP  | Deoxythymidine-5 triphosphate       |

The fluorinated pyrimidines produce their inhibitory and cytotoxic effects by two separate biochemical mechanisms. The metabolite FUTP gets incorporated into RNA. In addition dTTP, which is essential for further DNA production is stopped.

The most investigated of these agents is the pyrimidine analog 5-fluorouracil (5-FU). This agent was designed to inhibit cell proliferation by acting primarily on the synthesis phase (S-phase) of the cell cycle. 5-FU is converted enzymatically to the nucleotide 5-fluoro-2-deoxyuridine phosphate, a potent inhibitor of thymidylate synthetase which is required for the synthesis of phosphorylated deoxyribonucleotides for DNA synthesis (Figure 15). If these deoxyribonucleotides, which are required for incorporation into DNA, are reduced, mitotic activity is also reduced and cellular proliferation ceases. 5-FU inhibition of thymidylate synthetase can sometimes be reversed by the addition of thymidine through competitive inhibition of deoxyuridylate (Rich et al, 1960; Madoc-Jones and Bruce, 1968; Evans et al, 1980). However, 5-FU also has other modes of action, which may be less reversible. For instance, 5-FU is also converted to its corresponding ribophosphate, which is then incorporated into RNA. This results in the production of abnormal ribosomes, altered translation from messenger RNA and abnormal protein synthesis (Rich et al, 1960; Madoc-Jones and Bruce, 1968; Gressel et al, 1984).

The use of 5-FU as an anti-scarring agent was stimulated by the initial work of Blumenkranz and colleagues. They tested 5-FU in cell culture on dermal and conjunctival fibroblasts and also in an experimental animal model of intravitreal scarring (proliferative vitreoretinopathy) (Blumenkranz et al, 1982; Blumenkranz et al, 1984a). In the cell culture model, the cells were exposed continuously to 5-FU, based on the premise that continuous exposure was required to maintain inhibition of proliferation. 5-FU was found to have a broad therapeutic index with dose-dependency. The use in proliferative vitreoretinopathy has been limited, but Parrish and colleagues at the same centre carried out a series of studies on animal models of glaucoma filtration surgery (Gressel et al, 1984; Fantes et al, 1985; Desjardins et al, 1986; Heuer et al, 1986), followed by pilot studies in humans, culminating in a large multicentre study (The Fluorouracil Filtering Surgery Study Group, 1989). The regimen involved injecting the drug subconjunctivally every day for two weeks, based on the premise that a continuous inhibitory concentration of 5-FU had to be maintained in the tissue to inhibit fibroblast proliferation. However, local toxic ocular effects included corneal epithelial defects from 5-FU administered subconjunctivally (Heuer et al, 1984; Heuer et al, 1986; Rockwood et al, 1987), possibly due in part to leakage of the drug into the tear film. Furthermore, the regimen of repeated injections was inconvenient and impractical in many circumstances. Regimens involving fewer injections were introduced with some reduction in side effects, but the problems of subconjunctival injection administration

**Figure 15 Antiproliferative agents and their mode of action (adapted from Tahery and Lee, 1989)**

Group	Drug	Mode of Action
<b>1) Anti-metabolites</b>		
a) Folic acid analog	Methotrexate	Competitive inhibitor of the enzyme dihydrofolate reductase, blocking the formation of tetrahydrofolate and one carbon units
b) Pyrimidine analog	Fluorouracil	Converted to the active form fluorodeoxyuridine-monophosphate (FdUMP), which inhibits thymidylate synthetase
	Cytarabine (ara-a)	DNA polymerase inhibitor
c) Purine analog	Mercaptopurine	Sulfhydryl analog of hypoxanthine and guanine. Inhibits several steps in purine metabolism
	Thioguanine	Converted to a 6-Thioguanine-riboside-phosphate and is a feedback inhibitor of the initial step in purine biosynthesis
<b>2) Natural Alkaloids</b>		
a) Vinca alkaloids	Vinblastine Vincristine	Inhibit microtubular function in metaphase
b) Antibiotics	Actinomycin-D	DNA fragmentation, inhibition of DNA dependent RNA synthesis, membrane disruption, free radical formation and metal chelation.
	Daunorubicin	
	Doxorubicin (adriamycin)	
	Bleomycin	
	Mitomycin-c Mithramycin	
<b>3) Alkylating Drugs</b>		
These drugs introduce alkyl groups into proteins and nucleic acid molecules by covalent bonding.		
a) Nitrogen Mustard	Meclorothamine	Most chemically reactive of the nitrogen mustard family with a short half-life
	Cyclophosphamide	Intermediate chemical reactivity and half-life
	Chlorambucil	Slowest acting and the least toxic agent
	Melphalan	
b) Nitrosoureas	Carmustine Lomustine Streptozocin	Lipid soluble drugs which cross the blood-brain barrier
<b>4) Differentiating Agents</b>		
a) Fatty Acids	Sodium butyrate	Conformational change in DNA through inhibition of histone deacetylation
b) Retinoids	Vitamin A	



remained (Weinreb, 1987). 5-FU in combination with slow release preparations such as liposomes (Skuta et al, 1987), collagen implants (Kay et al, 1986), collagen shields (Sachdev et al, 1990) and slow release polymers (Lee et al, 1987; Jampel et al, 1990a) have been tried after experimental filtration surgery. However, these preparations may induce adverse responses, such as acute and chronic inflammatory changes after the injection of subconjunctival liposomes (Winter et al, 1987), collagen implants (Kay et al, 1986) and polymers (Jampel et al, 1990b) and these methods have not reached regular clinical use.

**Natural alkaloids:** Some natural alkaloids are also antiproliferative agents. These include plant alkaloids and antibiotic agents. Clinically important plant alkaloids are vinblastine and vincristine and important antibiotic agents are mitomycin-c, actinomycin (actinomycin D), daunorubicin, doxorubicin HCl (adriamycin), and bleomycin. Plant alkaloids cause mitotic arrest, whereas antibiotics inhibit DNA-dependent RNA synthesis. Mitomycin-c is an example of the multiple actions of the antiproliferative antibiotics. Mitomycin-c gets activated to an active species that alkylates, and possibly crosslinks DNA (Iyer and Szybalski, 1963). A further mechanism for the effect of mitomycin is free radical formation and subsequent cell damage (Moore, 1977). The final effects on DNA are alkylation and cutting of single strands of DNA. The end result is an inhibition of DNA synthesis (as measured by <sup>3</sup>H thymidine uptake) and an inhibition of RNA and protein synthesis (Lerman and Benyumovitch, 1965). Chromosomal breaks and short fragments of DNA are detectable in the cell after treatment with mitomycin-c (Makino and Ocada, 1974; Cook and Brazell, 1976). The other agents in this group include daunorubicin, whose effect is complemented by corticosteroids which serve to inhibit the inflammatory phase (Koerner et al, 1982). Doxorubicin is a good inhibitor of fibroblast proliferation but has undesirable toxic effects and hence a narrow therapeutic index. Bleomycin is an effective inhibitor of fibroblast proliferation in tissue culture (Ellis, 1982).

All these drugs have been shown to be effective in inhibiting ocular fibroblast proliferation in culture during continuous exposure (Lee et al, 1990). At the time of our experiments, there were reports in the literature of short single applications of mitomycin-c being used to prevent scarring after glaucoma filtration surgery. (Chen et al, 1990; Chen et al, 1987; Chen, 1983), suggesting that very short exposure times were sufficient to suppress cellular proliferation clinically, which if possible would be more convenient than repeated subconjunctival injections of 5-fluorouracil. However, this finding was met with scepticism because of the previous concept that continuous

exposure to the drug was required to achieve an inhibitory effect.

**Alkylating agents:** Alkylating agents inactivate cellular proteins and nucleic acids by the covalent bonding of alkyl groups to cellular molecules (Skipper et al, 1951) including nucleic acids, proteins, amino acids and nucleotides. The mechanism of action on DNA synthesis is controversial, but evidence favours primary damage to DNA rather than an inactivation of DNA polymerase or other enzymes (Ruddon and Johnson, 1968; Roberts et al, 1971). They function throughout the cell cycle. Mechanisms of action include inactivation of enzymes, depletion of critical amino acids or nucleic acid precursors, damage to nucleic acids, alterations in cell membranes or a combination of these actions (Colvin, 1982). Alkylating agents include the nitrogen mustards of which cyclophosphamide is an example, and nitrosourea drugs. Nitrogen mustards retard neovascularisation of wounded tissue (Ferguson, 1982; Karppinen and Myllarniemi, 1970; Myllarniemi and Petokallio, 1974) and reduce collagen and mucopolysaccharide production (Myllarniemi and Petokallio, 1974; Mullen et al, 1981) but they have not received much attention in ocular wound healing.

**Differentiating agents:** Agents which induce cellular differentiation in tumour lines are usually associated with a reduction in proliferation (Lotan, 1980; Ginburg et al, 1973; Kyritsis et al, 1984; Langdon et al, 1988). Retinol (vitamin A) causes tumour cells such as retinoblastoma, (Kyritsis et al, 1986; Kyritsis et al, 1984) neuroblastoma (Thiele et al, 1985) and embryonal carcinoma cells (Jones-Villeneuve et al, 1982) to differentiate. The proliferation of ocular cells including scleral fibroblasts (Kim and Stern, 1990) and retinal pigment epithelial cells which are an important component of scarring in the vitreous cavity, is inhibited by retinoic acid *in vitro* (Verstraeten and Wilcox, 1987), and retinoic acid inhibits overgrowth of confluent retinal pigment epithelial cells (Campochiaro et al, 1991). Cell migration and collagen gel contraction is also affected by retinoic acid (Savage et al, 1989). However, it is of interest that Joseph found that retinol significantly enhanced both the random and directed migration of Tenon's capsule fibroblasts (Joseph et al, 1988).

Sodium butyrate (NaB) is a naturally occurring 4 carbon fatty acid salt which inhibits proliferation in certain mammalian cells in culture (Ginburg et al, 1973; Wright, 1973; Prasad and Sinha, 1976; Kruh, 1982), but these effects are reversible. NaB has effects on the cell cycle (cells are arrested in G1) and affects the cytoskeleton, protein synthesis and cellular morphology (Ginburg et al, 1973; Wright, 1973; Prasad and Sinha, 1976; Kruh, 1982). NaB acts as a differentiating agent on a variety of tumour

cells including erythroleukaemia cells (Riggs et al, 1977), adenocarcinoma (Tsao et al, 1982), gliomas (Vinores et al, 1982), and retinoblastomas (Kyritsis et al, 1984). It modifies gene expression (Leibovitch et al, 1982) and it may do this by affecting histones, the basic proteins that interact with DNA (Boffa et al, 1978; Chahal et al, 1980) which may result in conformational changes in DNA. There may be a synergistic effect with steroids (Howard et al, 1991).

#### **1.34 Anti-contractile agents**

The role of collagen contraction in the failure of glaucoma filtration surgery has not been well established. Fibroblasts, as well as other cell types, require microtubules for their directed migration and proliferation. Colchicine and taxol are drugs that inhibit microtubular assembly and recycling, thereby impairing cell migration, proliferation, and contraction (Verdoorn et al, 1986; Lemor et al, 1986). These fibroblast functions are inhibited *in vitro* at drug concentrations well below the level of ocular toxicity (Davidson et al, 1983). Colchicine binds to the subunits of microtubules, causing their depolymerization and arresting cell division in metaphase (Borisly and Taylor, 1984). Taxol promotes the assembly of microtubules, stabilizing them once they are formed, and promotes the displacement of intermediate filaments (Schiff and Horwitz, 1980; Antin et al, 1981). Both mechanisms lead to disruption of normal cytoarchitecture and are responsible for the inhibitory effects of these agents.

A number of anti-proliferative agents have been tested for their anti-contractile properties. Although 5-fluorouracil itself was shown to have no effect (Van Bockxmeer et al, 1985) or minimal effect (Heath et al, 1986; Hartzler et al, 1989) on cell-mediated collagen matrix contraction, its metabolite 5-fluorouridine (5-FUR) seemed to have stronger inhibitory properties (Heath et al, 1986; Hartzler et al, 1989). However, long pretreatment with relatively high concentrations of the drug were necessary to produce these results. Daunomycin has been shown to have no additional effect on contraction (Verdoorn et al, 1986; Heath et al, 1990), but it was shown to reduce cell migration (Verdoorn et al, 1986). Corticosteroids like dexamethasone have been shown to have no effect on cell-mediated contraction (Van Bockxmeer et al, 1985), while others have reported a slight inhibitory effect (Adams and Priestley, 1988; Van Story-Lewis and Tenenbaum, 1986). In an experimental animal model, steroids had no effect on the adhesive and contractile properties of the injected cells (Chandler et al, 1992). In an early *in vivo* study, it was suggested that penicillamine might have a beneficial effect on intraocular proliferation by inhibiting the cross-linking of collagen (Weiss and Belkin,

1981), but in a collagen matrix contraction study, penicillamine proved ineffective (Van Bockxmeer et al, 1985).

As migration is an essential part of wound healing, the effect of a variety of drugs on fibroblast migration has also been tested using Tenon's capsule fibroblasts and migration chambers. This model has been used to exclude otherwise promising drugs which actually stimulated fibroblast migration to fibronectin (Joseph et al, 1988). Colchicine, cytochalasin b and particularly taxol (which all effect the cytoskeleton of the cell) were all shown to inhibit the migration of fibroblasts to rabbit aqueous humour (Joseph et al, 1989c). The efficacy of taxol in inhibiting fibroblasts and prolonging survival of filtering surgery in the monkey has been confirmed, prolonging function of the drainage bleb up to 13 weeks against the blebs in control eyes which lasted only 1 week (Jampel et al, 1990b).

### **1.35 Anti-collagen cross-linking agents**

Agents interfering with collagen synthesis and polymerization may be more effective in the later stages (Ellis, 1982) of the healing process. The final phase of wound healing, the maturation phase, involves the modification of collagen fibre alignment and cross-linking. Antineoplastic agents that affect collagen metabolism, as previously mentioned, would impair this stage secondary to their effect on fibroblast growth and proliferation. Other, more specific drugs are available that help control overabundant collagen deposition. Local modification of collagen metabolism in scar tissue is possible by the intralesional use of corticosteroid triamcinolone (Giamgiacomo et al, 1986; Wilson and Reaves, 1987). This drug serves to decrease collagen synthesis and increase collagenase activity (Harris and Krane, 1971). Triamcinolone also inhibits wound contraction (Peacock and Madden, 1969). However, thinning of conjunctiva over the site of drug application may result (Wilson and Reaves, 1987; Ball et al, 1986). Colchicine is also an effective drug which interferes with the microtubule-mediated intracellular translocation of collagen in fibroblasts and therefore inhibits fibroblastic secretion of collagen (Diegelmann and Peterkofsky, 1972).

Beta-aminopropionitrile (BAPN) and D-penicillamine are drugs which inhibit collagen cross-linking. BAPN irreversibly inhibits lysyl oxidase, thereby preventing any further cross-linking of the tropocollagen fibrils (Diegelmann and Peterkofsky, 1972; Moorhead et al, 1987). D-penicillamine, a copper chelator (Albergoni et al, 1975), interferes with de novo collagen synthesis by inhibiting the cross-linking of collagenous fibrils at a later stage than BAPN. This results in an alteration of biochemical solubility and tensile

strength of the scar tissue (Siegel, 1977). D-penicillamine also exhibits anti-inflammatory effects (Chen et al, 1977; McGuigan et al, 1987). So far no serious ocular or systemic toxicity has been reported for BAPN or D-penicillamine.

The lathyrogenic agents, D-penicillamine and betaaminopropionitrile (BAPN) have been used to prevent excessive collagen formation post operatively after filtering surgery. BAPN has been shown to clinically decrease keloid formation (Peacock, 1981), and more directly relevant to the eye limits the degree of fornix contracture after conjunctival alkali burns in rabbits (Moorhead, 1981). D-penicillamine may also have anti-inflammatory effects (Chen et al, 1977). McGuigan and colleagues tested both BAPN (intramuscularly and topically) and d-penicillamine (subconjunctivally) in rabbits (McGuigan et al, 1986) and in monkeys with laser induced glaucoma (McGuigan et al, 1987). They found these agents temporarily delayed healing.

#### **1.4 Justification and aims**

In the context of the previously described research on wound healing after glaucoma filtration surgery, it was felt that two areas needed further investigation. The first area concerned the biological stimulatory effect of normal and glaucomatous aqueous on Tenon's capsule fibroblasts, and the components of the aqueous that were important in stimulating this behaviour. The second concerned the effects of different antiproliferative agents on components of this behaviour *in vitro* and *in vivo*. Thus, the broad aims of this thesis were to:

- 1) Establish if there was any significant difference in the biological stimulation induced by aqueous from glaucoma and cataract controls.
- 2) Determine the effects of various stimulatory molecules found in human aqueous humour on human Tenon's capsule fibroblast migration, proliferation and collagen production.
- 3) Investigate the effects on Human Tenon's capsule fibroblasts of a variety of antiproliferative agents using *in vitro* and *in vivo* models.

Clearly these broad aims evolved as results became available throughout the course of these experiments, and the logic for this evolution is explained in the subsequent part of this thesis.

## CHAPTER 2 MATERIALS AND METHODS

### 2.1 Cell culture techniques/specimen collection

#### 2.11 Primary culture of human Tenon's capsule fibroblasts

Tenon's capsule from subconjunctival tissue was dissected from human donor eyes obtained within 24 hours of death. Redundant tissue was also obtained from patients during operations requiring routine removal of Tenon's capsule (squint and glaucoma surgery). The cells were then cultured from a method previously described by Joseph (Joseph et al, 1987). The tissue was cut into pieces of 2 mm diameter and immediately placed in the transport media Dulbecco's modified Eagle's medium (DMEM) (Gibco) with amphotericin B (0.25 microgram/ml), penicillin (100 IU/ml) and streptomycin (100 microgram/ml) with 25mM Hepes buffer. The pieces of tissue were placed in 25cm<sup>2</sup> flasks (Sterilin) and were fixed down with a glass cover slip and a small drop of wax at the corner of the cover slip. This method was developed to facilitate refeeding of the explant during early growth without losing the tissue. In addition, this method ensured tissue fixation and adhesion to the tissue culture surface which speeded the rate of fibroblast outgrowth. The cells were fed twice weekly with DMEM supplemented with 10% foetal calf serum (FCS)(Gibco), and antibiotics and incubated in a humidified mixture of 5% CO<sub>2</sub> and air at 37°C in an incubator (Leec) with a continuous flow water jacket. Fibroblasts were usually noted within 1-2 weeks of culture and the flasks were confluent by 3 to 4 weeks.

#### 2.12 Maintenance of cell cultures

Feeding procedures were carried out in a laminar flow hood (Bassaire) using well established aseptic techniques (Freshney, 1987). Solutions were prewarmed in a water bath (Grant instruments) at 37°C. The cultures were fed using disposable sterile pipettes after pouring out old media. Approximately 6 ml of media were used per 25 cm<sup>2</sup> area of flask (Cell-Cult flasks, Sterilin). At confluence the cells were then passaged using in a 1:3 ratio. The cells were assessed weekly to ensure normal morphology and doubling times. Cells were used between 3rd and 6th passage as the growth curves of five different fibroblast lines grown from explants within these passage numbers were all found to be consistent within these passage numbers. At later passages the rate of cell proliferation began to decrease. The cells were detached

from their flasks using warmed (37°C) 0.05% trypsin and 0.53mM EDTA (Gibco) for 3 minutes after gentle rinsing three times with prewarmed (37°C) Mg<sup>2+</sup> and Ca<sup>2+</sup> free PBS (Gibco). The cells were viewed at X 100 magnification with a phase contrast inverted microscope (Nikon Diaphot, Nikon). When most of the cells were seen to be rounded up, the action of trypsin was stopped by adding DMEM containing 10% newborn calf serum (Gibco). The cells were then divided in a 1:3 ratio.

## **2.12 Aqueous collection**

Aqueous humour was collected from patients undergoing cataract and glaucoma surgery as part of the routine surgical procedure. These patients had no other ocular disease. All specimens were taken as close to the start of the operation as possible to sample aqueous before any possible breakdown in the blood/aqueous barrier due to ocular manipulation. Breakdown in the barrier would result in a rise in aqueous proteins and spurious levels of stimulatory molecules in the aqueous humour.

Aqueous humour was aspirated through a very fine (27 gauge) needle attached to a 1 ml syringe as part of a routine paracentesis. Care was taken not to touch the corneal endothelium, iris or lens with the end of the needle, as contact with intraocular structures has been shown to disrupt the blood aqueous barrier (Tripathi et al, 1989). Approximately 50-100  $\mu$ l was obtained from each eye without causing flattening of the anterior chamber. The anterior chamber was then reformed with balanced salt solution or viscoelastic and the operation completed. The samples were then transferred to siliconised tubes to prevent loss of fibronectin and other biologically active molecules due to adherence onto the side of the container. The tubes were then stored at -70°C until assayed. Tubes of normal bovine aqueous that had been stored for up to 9 months did not have significantly lowered levels of fibronectin compared with samples that had been stored for only one month. 4 tubes of bovine aqueous (240 $\mu$ l) were divided into 3 aliquots of 80 $\mu$ l. These were frozen at -70°C for 3 and 9 months, and then tested against a standard curve made up from commercially available fibronectin (Sigma).

## **2.2 Fibronectin enzyme linked immunosorbent assay**

Levels of fibronectin in the vitreous were measured using an double sandwich enzyme linked immunosorbent assay. The antibody was immobilised on the tube (Engvall and Perlmann, 1971), and the sample was then placed in the tube. Fibronectin

in the sample then bound to this antibody. After washing off the remaining sample a second antibody labelled with an enzyme (Rubinstein et al, 1972) was placed in the tube, and this reacted with the immobilised fibronectin. The enzyme linked to the second antibody was then used to produce a colour reaction to quantitate the amount of fibronectin. The procedure was initially standardised to obtain the optimal binding range by varying concentrations of both primary (1:200, 1:500, 1:1000, 1:2000) and secondary (1:200, 1:500, 1:1000, 1:2000) antibodies, primary antibody incubation times (6 hours, 18 and 36 hours), sample volume (5, 10 and 20  $\mu$ l) and sample incubation times (30 minutes, 1, 2 and 4 hours).

Ninety-six well microlitre plates (Sterilin) were washed in 0.1% decon detergent to enhance antibody binding, and then washed several times in distilled water and dried overnight. The plates were then coated overnight at 4°C with a 100  $\mu$ l of polyclonal rabbit anti-fibronectin antibody (Dakopatts) diluted 1:1000 in phosphate buffered saline pH 7.2 (PBS)(Sigma). The plates were then washed three times with PBS/Tween 20 (0.1% v/v) (Sigma) and coated with 200  $\mu$ l of 3% bovine serum albumin (Sigma) in PBS at 37°C for an hour to prevent non-specific binding. The plates were then washed with PBS/Tween and 10  $\mu$ l of aqueous sample were placed in three wells, and made up to 100  $\mu$ l with PBS/Tween. Standards were made up from human serum fibronectin (Sigma) and run in the same experiment in concentrations from 0.1 to 25  $\mu$ g/ml.

The samples were incubated at room temperature for two hours after which the plates were washed with PBS/Tween and 100  $\mu$ l of rabbit antifibronectin conjugated to peroxidase (Dakopatts) 1:500 with PBS/Tween was added to each well and incubated for one hour at room temperature. The wells were washed with PBS/Tween and a colour reagent Tetra-methyl benzidine HCL (2mg in 12 ml) in citric acid (0.035 molar pH 5.0)(Both Sigma) and 5 microlitres of H<sub>2</sub>O<sub>2</sub> (Sigma) were added. The colour reaction was stopped with molar H<sub>2</sub>SO<sub>4</sub> and the absorbance measured on an automatic ELISA reader at 450 nm.

A standard curve was constructed and used to determine the levels of fibronectin in the aqueous samples. Samples were assayed in 1:2 and 1:4 dilutions, and if possible reassayed in duplicate or triplicate at an appropriate single dilution, and levels calculated as an average of the three readings. To check for any intra- or inter assay variations, four samples were run in parallel in the same assay, and 4 samples run in sequential assays. The intraassay variation was 7.97%  $\pm$  1.98 SEM and the interassay variation was 14.35%  $\pm$  3.85 SEM. In view of this interassay variation, after all the preliminary standardisations assays were done, one large single assay was run with all the samples to be compared to minimise interassay variation.



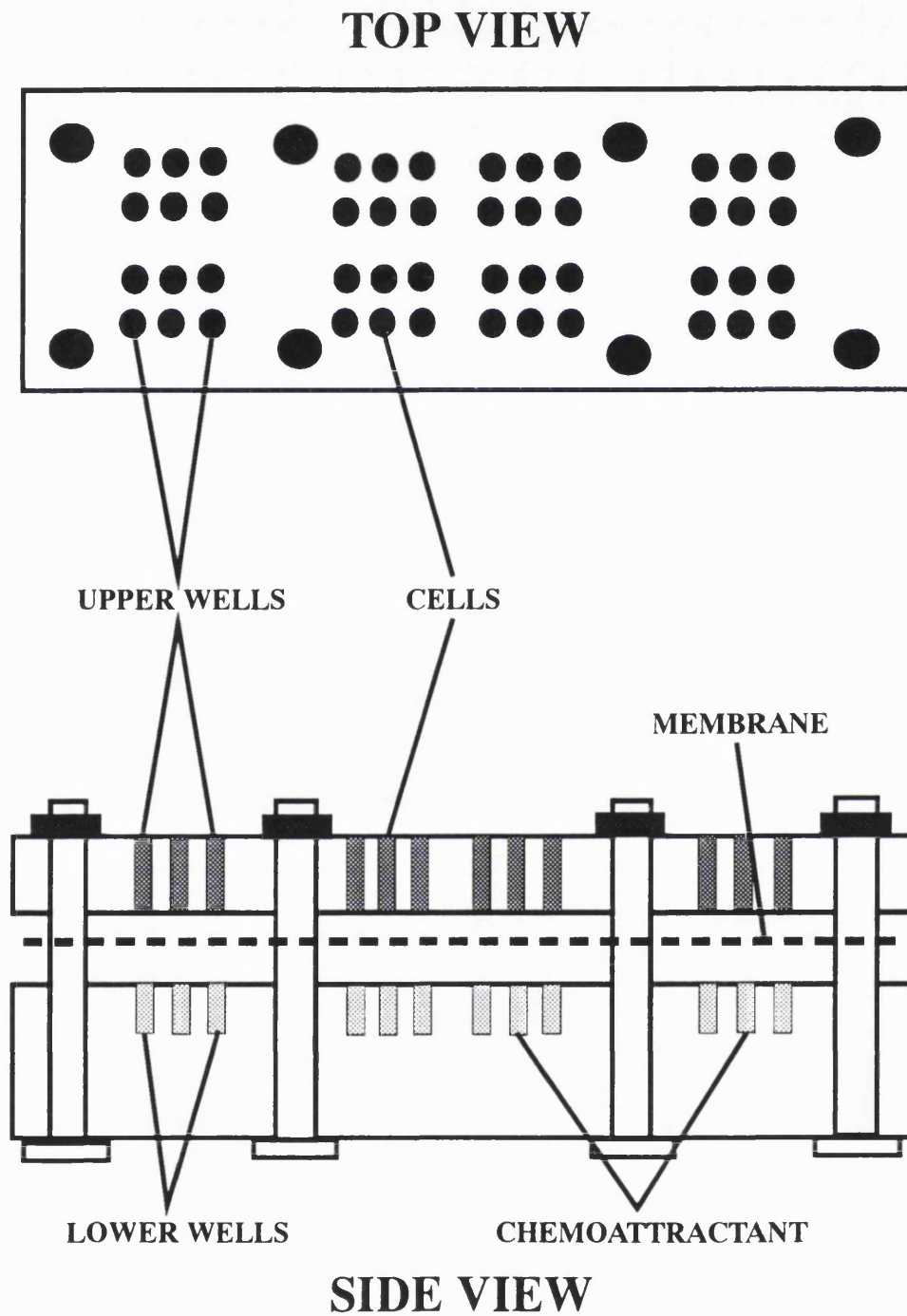
## 2.3 Migration assays

### 2.31 Migration assay (modified Boyden chamber)

Human Tenon's capsule fibroblasts between third and sixth passage were used in the migration assay. This was because the proliferation curves were consistent between third and sixth passage. This was also done to provide some consistency between the proliferation and migration assay. Cellular migration has been studied *in vitro* using several assay systems including orientation chambers (Zigmond, 1977) under agarose (Nelson et al, 1978) and in two compartment Boyden chambers (Zigmond and Hirsch, 1973). Modified forty-eight microwell two tiered blindwell migration chambers (Neuro Probe) based on the original migration chambers described by Boyden in 1962 were used for these experiments (Boyden, 1962). The modified chambers were used as they have 48 microwells and facilitate the analysis and comparison of multiple samples (Figure 16). In addition, the small volume of the chambers allows the best use of very limited volumes of biological samples such as aqueous. The apparatus is a perspex chamber, the lower part containing 48 round bottomed wells of 25  $\mu$ l capacity, and upper wells which have a 50  $\mu$ l capacity. They are separated by a silicone gasket and polycarbonate membranes with pores of 10  $\mu$ m diameter, coated with polyvinylpyrrolidone (PVP)(Nucleopore). Polycarbonate membranes with pores of 10 $\mu$ m thickness were used, based on previous experiments in the laboratory using pore sizes ranging from 6 to 12 $\mu$ m which showed 10 $\mu$ m to be the optimum pore size. Membranes containing the wetting agent polyvinylpyrrolidone were treated with gelatin (Sigma) to promote the adherence of cells (Postlethwaite et al, 1976; Joseph et al, 1987). The membranes were heated to 60°C in a solution of 0.5% glacial acetic acid for 20 minutes. After that, they were washed twice with distilled water and coated in a solution of 0.5% glacial acetic acid for 20 minutes, washed with distilled water and coated in a solution of porcine gelatin, type 1, 300 bloom, (5mg/l) in distilled water at 100°C for one hour, then air and oven dried for one hour at 100°C.

Aqueous samples were diluted in serum free medium to produce a 20% solution. This was based on standardisation experiments using concentrations of a sample of pooled aqueous from 5% to 60% as the chemoattractant. Samples from this pooled

Figure 16 Modified 48 well two tiered blindwell Boyden Migration Chamber



aqueous at concentrations of 5, 10, 20, 40 and 60% were used in triplicate in the lower chamber, and the number of migrated cells counted at the end of the five hour migration period. At concentrations greater than 20%, the number of cells migrated began to plateau sharply. Therefore, a 20% concentration of aqueous was chosen to optimise fibroblast migration while using a minimum volume of aqueous. Twenty five microlitre aliquots of the diluted aqueous were added to the lower chambers of the 48 well apparatus and covered by the polycarbonate membrane. The chamber was then covered with a cover slip and allowed to equilibrate in an incubator for 30 minutes. Preconfluent fibroblasts were fed with fresh DMEM and 10% FCS the day before the experiment. The cells were detached from their flasks using warmed (37°C) 0.05% trypsin and 0.53mM EDTA (Gibco) for 3 minutes after gentle rinsing three times with prewarmed (37°C) Mg<sup>2+</sup> and Ca<sup>2+</sup> free PBS (Gibco). Exposure to trypsin for periods longer than this has been shown to reduce chemotactic activity (Postlethwaite et al, 1976). The enzymatic treatment was terminated by the addition of DMEM containing 20% FBS, and then centrifuged at 300g for 10 minutes. The cells were resuspended in serum-free medium and centrifuged again at 300g for 5 minutes. The cells were then resuspended in 1 ml of serum free DMEM and 40  $\mu$ l diluted in isoton (Coulter), and counted using a Coulter Counter (Model ZF, Coulter). The dilution required to achieve a concentration of 40,000 cells per well of 50  $\mu$ l ( $8 \times 10^5$ /ml) was calculated and the appropriate volume of media added. The number determined from previous standardisation experiments to establish the optimal number of cells per well. Fifty microlitre volumes containing the cells were then added to the upper wells of the migration chamber.

The whole apparatus was incubated in 5% CO<sub>2</sub> at 37°C for five hours, following which the membrane was removed from the chamber, placed in 100% ethanol for 15 seconds, and air dried. Membranes were stained with haematoxylin (Difco) for 30 minutes, washed three times in cold distilled water and mounted on a glass slides under a glass cover slip with Permount solution. Migrated cells on the undersurface of the membrane were counted in high power fields under oil immersion (x 1000)(Vickers ML 1300, Vickers Instruments) per well. Twenty fields were examined in each of the 48 chambers. This represented 0.54mm<sup>2</sup> or 1/15th of the membrane in each chamber. The samples were assayed in triplicate and an average calculated from the three samples.

A Zigmond-Hirsch (Zigmond and Hirsch, 1973) chequerboard analysis was carried out to determine whether the effect of aqueous on human Tenon's fibroblasts was primarily chemotactic or chemokinetic. The chequerboard analysis involves using

different combinations of the chemoattractant above and below the membrane so that negative, positive and no gradients (but with an increasing concentration of chemoattractant) are achieved. The checkerboard analysis was performed on four specimens of aqueous humour taken from patients undergoing cataract surgery and four specimens of patients with primary open angle glaucoma. Aqueous humour was added to the upper and lower wells of the modified Boyden chambers to expose the fibroblasts to:

- 1) A positive gradient of chemoattractants (increasing concentrations of aqueous humour in the lower wells only)
- 2) A negative gradient of chemoattractants (increasing concentrations of aqueous humour added to the only to the upper wells, in conjunction with the cells)
- 3) No gradient of aqueous humour but merely an increasing concentration of aqueous humour, equal in both upper and lower wells.

### **2.32 Modifications for growth factor migration assay**

The procedure was followed as above, and modified so that solutions of DMEM were made up with 1% bovine serum albumin (Sigma) which was then filter sterilised (Grant et al, 1992). Growth factors are much less stable than fibronectin and albumin was added to stabilise the growth factors in solution. Membranes were recovered after incubation with the cells for five hours and cells on the attachment side were scraped off using a specially constructed flexible rubber blade, leaving only those cells that had migrated through pores of the filter. The membranes were scraped as the counting was done with an automated image analyser, which was not available for the first series of experiments. This system is much quicker than manual counting and it reduces the chance of observer bias.

Membranes were submerged in ethanol to fix the cells, which were then stained with Leukostat solutions (Fisher) and mounted onto glass slides. DMEM containing 1% BSA (Sigma) was used as a negative control in each experiment to determine random cell migration. DMEM containing 20% FCS and 1% BSA was used as a positive chemotactic control in each experiment. Each test condition was assayed with a minimum of three replicate wells.

Cell migration was measured using a Zeiss IBAS Image Processing system (Zeiss). For each well, the number of cells that had migrated through the filter was calculated by averaging the number of cells counted in three separate (40X) fields. The values for the three replicate wells were then averaged. Several experiments were counter

checked using manual counting and the cell number counts were similar, with the image analyser tending to over count relatively consistently by about 5%. Each migration experiment was repeated a minimum of twice.

### **2.33 Addition of fibronectin antibody**

Fibronectin polyclonal antibody was added to aqueous humour at different concentrations in an attempt to block any migration due to the chemotactic effect of fibronectin. Polyclonal antibody was used as fibronectin antibody has many binding sites and a polyclonal antibody was thought to be more likely to block the majority of binding sites. This would also provide an indirect measure of the contribution of aqueous fibronectin to the chemotactic properties of aqueous. Aqueous from several controls was pooled and polyclonal rabbit anti-human fibronectin antibody (Dakopatts) was added to the aqueous 20%/DMEM solution to make up antibody dilutions of 1:100, 1:500, 1:1000, 1:5000, and 1:10,000. Controls included DMEM alone and DMEM with antibody at a concentration of 1:100. Migration to fibronectin at a similar concentration to aqueous humour (5  $\mu\text{g/ml}$ ) was also assessed with and without fibronectin antibody at a concentration of 1:100 to determine how effective this particular antibody was at blocking the chemotactic effect of fibronectin on fibroblasts.

### **2.4 Collagen production ( $^3\text{H}$ proline uptake assay)**

Human Tenon's fibroblasts were seeded onto 24 well plates at a density of 50,000 cells/well (25,000/cm<sup>2</sup>). This is a higher density than for proliferation experiments, as preliminary experiments showed that a larger number of cells is required to optimise  $^3\text{H}$  proline uptake, and this is enhanced by having confluent cells. Collagen synthesis was determined using a method described by Diegelmann and colleagues (Diegelmann et al, 1990) and refined by Low et al (Low et al, 1991). The TGF- $\beta$ 1 isoform was used as it was available commercially and TGF- $\beta$ 1 and 2 are equipotent in the induction of matrix protein synthesis (Roberts and Sporn, 1993). After exposure to the growth factors EGF, bFGF, and TGF- $\beta$ 1 for 24 hours, the cells were pulsed with DMEM containing 1% BSA, 10  $\mu\text{Ci/ml}$  of  $^3\text{H}$  proline (Sigma) 50  $\mu\text{g/ml}$  ascorbic acid (which is a reducing agent and maintains prolyl hydroxylase in an active form, which in turn stabilises collagen) and concentrations of the growth factors from  $10^{-7}$  to  $10^{-12}$  Molar. Each treatment concentration was repeated in triplicate. The cells were incubated for 20 hours in 5%  $\text{CO}_2$  at 37°C. At the end of this period, extra wells were also counted

with the Coulter counter to ensure that any possible increase in  $^3\text{H}$  proline was not due solely to an increase in cell number. The pulse was terminated by heating the plate for 10 minutes at  $90^\circ\text{C}$  and agitating for 30 sec per well with a pipette.  $200\ \mu\text{l}$  of the homogenate was removed from each well and 1 ml of 1 mg/ml BSA solution mixed in to provide a carrier protein. Total protein was precipitated with approximately 5% trichloroacetic acid and washed six times by repeat centrifugation at 200 rpm followed by aspiration of the supernatant and precipitation with 10% TCA in a 1 mM solution of cold L-proline (Sigma).

TCA was extracted by adding cold ethanol:ethyl ether (3:1) after the last centrifugation and the dried protein incubated in 0.5 ml of an incubation buffer (60  $\mu\text{mol}$  Hepes buffer pH 7.2, 1.25  $\mu\text{mol}$  N-ethylmaleimide and 0.25  $\mu\text{mol}$   $\text{CaCl}_2$ ) for four hours in a water bath, shaking periodically. The protein suspensions were precipitated with 0.5 ml of a 5% TCA solution followed by 0.5 ml of a 10% TCS solution. Total protein was then freed of TCA and dried. This was then digested with 10 units of bacterial collagenase for four hours in 0.5 ml incubation buffer. Non-collagen protein was precipitated with 5% and 10% TCA solutions and the supernatants saved as the collagen protein. These were then placed in 10ml scintillation vials (Packard) with scintillation cocktail (Packard) in a 1:7 dilution, vortexed and placed in total darkness overnight to minimise chemiluminescence, Radioactivity (disintegrations/minute) in each vial were counted for one minute the next day using a liquid scintillation counter (Packard 1900-CA).

## **2.5 Assays of cell proliferation and viability**

### **2.51 Manual counting**

#### **2.51 a) Radiation assay**

Human Tenon's capsule fibroblasts were seeded at a density of 2500 cells/well ( $7500\ \text{cells}/\text{cm}^2$ ) in four wells of 96 well plates (Sterilin). Three groups of 96 well plates were used with eight plates in each group. The wells were 55 cm apart to minimise the chance of any scattering of radiation to adjacent wells. The cells were allowed to incubate and settle for 24 hours. The medium was then replaced with DMEM buffered with 25mM Hepes and the culture plates were transported to the radiation therapy room. Each plate was kept out of the incubator for the same length

of time. The centre of each well was then placed in contact with the centre of the strontium-90 applicator, which covered the entire surface area of the well. The calibration certificate issued with the probe was used to calculate the exposure time for each well. The dose rate for the applicator was 4.8 CGy. Doses of 100, 250, 500, 750, 1000, 1500 and 3000 CGy were delivered to the appropriate wells.

After treatment, the control and irradiated cells were returned to the laboratory where they were fed with fresh F10. Then, at day 0, day 3, day 7 and day 14, the appropriate wells were rinsed gently with phosphate buffered saline, fixed with ethanol and stained with haematoxylin. The number of cells in a field 0.75mm X 0.55mm were counted and this was repeated in different areas of the well 10 times for each well (approximately 13% of the total well surface area). The mean count for each well was calculated, and the mean and standard error of the four wells were then calculated and used for statistical analysis. This method was used because preliminary experiments in our laboratory had shown it to be more consistent and accurate than Coulter or haemocytometer readings when dealing with small numbers of cells in 96 well plates. Inter- and intra-observer comparisons were also made using the formula

$$\frac{(\text{Observer reading 1} - \text{Observer reading 2})}{(\text{Observer reading 1} + \text{Observer reading 2})/2} \times 100$$

The intraobserver variation was 6.77% and the interobserver variation was 9.93%. The results were analysed using analysis of variance and confidence intervals were derived for the different doses at each time interval. Regression analysis was also used to calculate the trend with increasing radiation dose for each day, using Minitab (r) statistical software (Minitab Corporation), registered at the Institute of Ophthalmology.

## 2.51 b) 5-fluorouracil and sodium butyrate 1-14 days treatment assay

Fibroblasts were seeded on 25 cm<sup>2</sup> flasks at a density of 5000 cells/cm<sup>2</sup>. After allowing a day for settlement, groups of four flasks were treated with different concentrations of 5-FU; 0, 0.01, 0.1, 1, 10, 100 and 1000 µg per ml in DMEM/10% FBS for 1 day. This procedure was then repeated with the same concentrations of 5-Fluorouracil (5FU) (David Bull laboratories), but with treatment periods of 3, 6 and 12 days. At the end of the different treatment periods, the cells were gently washed three

times with Hank's balanced salt solution (HBSS) (Gibco). From then on, the cells were fed with DMEM/10% FBS supplemented with 10% foetal bovine serum (Gibco). All cells were fed every three days with either DMEM/10% FBS/5-FU or DMEM/10% FBS depending on the treatment regimen.

Five areas of 0.75 mm x 0.55 mm in each flask were marked and the number of cells within these areas was counted using a phase contrast microscope (Nikon Diaphot, Nikon) at days 0, 1, 3, 6, 12, 18, 24 and 30. The average number of cells per field for each flask was calculated. This was repeated for the other 3 flasks receiving the same concentration of drug for the same duration, and an average count calculated for the group of four. This experiment was repeated using new cells, but treating the cells with sodium butyrate (Sigma) at concentrations of 0, 1.1, 11, 110, 1100, 11000  $\mu\text{g/ml}$  (equivalent to 0, .01, 0.1, 1, 10 and 100mM solutions) for 1, 3, 6 and 12 days. Inter- and intraobserver comparisons were also made as described previously. The intraobserver variation was 7.27% and the interobserver variation was 11.09%.

Initially, only 5-fluorouracil was used, and sodium butyrate was used for the longer term studies. For the subsequent shorter term studies, more powerful agents were used, which had long term effects, unlike 5-fluorouracil, 5-fluorouridine, and mitomycin-c. Sodium butyrate was not used for the short term experiments because pilot experiments revealed that it did not significantly affect long term proliferation after a 5 minute exposure, even a maximal concentrations (100mM).

## **2.52 Coulter counting (5 minute exposures to 5-fluorouracil, 5-fluorouridine and mitomycin-c)**

Human Tenon's capsule fibroblasts were seeded into six 48 well plates (Costar) at a density of 10,000 cells/cm<sup>2</sup>. They were allowed to settle for 24 hours, and were then exposed to one of the antiproliferative drugs for five minutes. Mitomycin-c (Kyowa) was tested at concentrations of 1000, 100, 10, 1, 0.1, 0.01 and 0.001  $\mu\text{g/ml}$  of DMEM, 5-FUR (Sigma USA) at concentrations of 15000, 10000, 5000, 1000, 100, 10, 1 and 0.1 in DMEM and 5-fluorouracil (David Bull laboratories) at concentrations of 25000, 15000, 10000, 5000, 1000 and 100  $\mu\text{g/ml}$  in water. Control cells were exposed to DMEM alone for 5 minutes. Four wells were also exposed to distilled water as an extra control to assess the long term effects of a five minute exposure to a hypotonic solution, as the 5-fluorouracil was preformulated in distilled water.

Four wells were exposed to each concentration of drug. Wells were then slowly



aspirated with a very fine pipette tip attached to vacuum suction, and the well was then gently filled with 1 ml of Hank's balanced salt solution (HBSS)(Gibco). This was repeated twice, after which the cells were fed with DMEM/10% FBS. Wells were then checked with phase contrast microscopy (Nikon Diaphot, Nikon) to monitor for loss of cells during the washing process. Because of the careful washing, the only loss was in a very small area at the corner of the well, where the very fine pipette tip touched the bottom of the cell culture well.

The medium was replaced every three days with DMEM/10% FBS. On days 0, 3, 6, 12, 24 and 36, plates were washed with  $\text{Ca}^{2+}$ -,  $\text{Mg}^{2+}$ -free phosphate buffered saline (Sigma) and the cells were removed with trypsin/EDTA. Wells were checked by microscopy to confirm that the cells had detached and were single cell suspensions. Cell numbers were then assessed using a Coulter counter (Coulter Model ZM, Coulter) and the average cell numbers calculated from the four replicate wells. Average cell numbers were compared for statistically significant differences using analysis of variance and Bonferroni's multiple testing criteria (Milliken and Johnson, 1984). Analysis of variance was used because of the multiple points which required testing, to determine if there was significant differences at each time point. Bonferroni's multiple testing criteria were used to determine the significant differences between each different treatment concentration, to reduce the chance of detecting a significant difference occurring by chance due to the multiple points. To assess the effects of the antiproliferative drugs on cell morphology, 25cm<sup>2</sup> tissue culture flasks were seeded with the same cells at the same density and treated with the same regimen. Cells in these flasks were then photographed on days 0, 3, 6, 12, 24 and 36.

### **2.53 BrDu Uptake**

BrDU uptake was assessed to determine if and when treated cells began to take up DNA precursors during and after treatment. A immunohistological technique was used rather than thymidine uptake, despite the greater technical difficulty. This was to establish if there was any relation to the morphology of the cell, or spatial distribution of the cells. These observations could not be made just by using tritiated thymidine. Fibroblasts were seeded onto eight 96-well plates (Sterilin) at a density of 2500 cells/well (7500/cm<sup>2</sup>) and allowed to settle for one day. 7500 cells were used as pilot experiments had determined that this was an optimum number to allow proliferation over the experiment period. This was a similar cell density to that used in the cell number counting experiment. Each plate was divided into 12 groups of four

wells which were treated with different concentrations of 5-FU in DMEM/10% FBS; 0, 1 and 100  $\mu\text{g}$  per ml for different periods of 1, 3, 6 and 12 days. At days 0, 1, 3, 6, 12, 18, 24 and 30, one plate was incubated with 1:1000 bromodeoxyuridine (BrDU)(Amersham) for four hours. The plate was then washed gently with HBSS, fixed in 70% methanol, and air dried and frozen at  $-20^{\circ}\text{C}$ . The rest of the plates were treated with the different concentrations of 5-FU for the varying time periods, washed with HBSS and refed with DMEM/10% FBS after the treatment period was over. The cells were fed every three days.

At the end of 30 days, the cells in all the fixed plates were rehydrated with phosphate buffered saline (PBS) (Gibco) and incubated with 3% hydrogen peroxide (Sigma). They were then washed and incubated in 5% goat serum (Sigma), and mouse anti-bromodeoxyuridine antibody (Amersham) was added for one hour at  $37^{\circ}\text{C}$ . Biotinylated rabbit anti-mouse IgG antibody (Dakopatts) was added and diluted in 1% goat serum/PBS. Peroxidase conjugated avidin (Dakopatts) was then added and 3-amino-9-ethylcarbazole (Sigma) with  $\text{H}_2\text{O}_2$  was used to produce a red colour reaction. The cells were stained with haematoxylin and glycerol pipetted into the wells. The wells were viewed and photographed with a phase contrast microscope. Five fields of  $0.75\text{ mm} \times 0.55\text{ mm}$  per well were used. The total number of cells per field and the total number of cells positive for BrDU were counted, with an average calculated for each well. Five fields from each of the other three wells that received the same treatment regimen were also counted using five fields. This was repeated for all the other wells. The percentage of positive cells was derived by dividing the average number of positive cells by the average total number of cells.

This procedure was repeated using the same cells treated with 0, 1, and 100 millimolar concentrations of sodium butyrate in DMEM/10% FBS for the same periods of 1, 3, 6 and 12 days. Sodium butyrate was used because it is a sort actin inhibitor cell proliferation. For the shorter experiments, more potent inhibitors were used as sodium butyrate does not significantly affect proliferation in the long term. Differences in cell number were assessed for statistical significance using analysis of variance and Bonferroni's multiple testing criteria using Minitab (r) statistical software (Minitab Corporation). Significance was defined as a p value of  $<0.05$ .

## **2.54 Thymidine uptake (Growth factor stimulation and $\beta$ -radiation treatment)**

Human Tenon's capsule fibroblasts were seeded onto 24 well plates ( $2\text{ cm}^2$ ) (Costar) at a density of 20,000 cells/well ( $10,000\text{ cells/cm}^2$ ).  $10,000\text{ cells/cm}^2$  were

used as preliminary standardisation experiments had shown that this number achieved a sufficiently high density to maximise the thymidine uptake and differences, while still pre-confluent to allow proliferation without contact inhibition over the course of the experiment. Cells were allowed 48 hours to attach to the plates in DMEM/10% FBS. They were then washed with PBS and DMEM without serum was added and the cells left to incubate for 48 hours, to maximise the difference between stimulated and unstimulated cells. Then DMEM /1% bovine serum albumin (Sigma) with different concentrations of either human recombinant epidermal growth factor (EGF), basic fibroblast growth factor (bFGF) or transforming growth factor  $\beta^1$  (TGF- $\beta^1$ ) (all Chiron Corporation) were made. After 24 hours incubation with the growth factors, 2 $\mu$ Ci/ml of  $^3$ H-thymidine was added to each well for a further 24 hours.

Millipore filter plates were placed on ice and 75  $\mu$ l of ice cold 10% TCA added to each well with a repeating pipette. One cell counting vial was used per well. 10 ml of isotonic diluent was used per vial. Cells were washed 2 times with ice cold  $Ca^{++}$ - $Mg^{++}$  free PBS, then incubated in 150  $\mu$ l of 0.1% trypsin/5% EDTA for 10 minutes at room temperature, ensuring that the trypsin EDTA solution covered the entire surface of the well. The trypsin was stopped with 100  $\mu$ l/well of ice cold BSA 2 mg/ml) and soybean trypsin inhibitor (500 ng/ml) (Sigma). The contents of each well were split into three 75  $\mu$ l fractions. One fraction was used for cell counts and 2 fractions for wells in the Millipore filter plates.

After all the cells were harvested from each plate an additional 75  $\mu$ l of ice cold 10% TCA was added to each filter. The filters were allowed to remain on ice for at least 10 more minutes to complete precipitation of the DNA, RNA and protein. Filter plates were then washed using a vacuum manifold 3 times with 100  $\mu$ l of ice cold 5% TCA and 2 times with 100  $\mu$ l of ice cold 95% ethanol. The wells were air dried, and the wells were punched out, collected into 7 ml vials (Fisher) with 2.5 ml of scintillation fluid (ScintiVerse<sup>TM</sup> Fisher) and the incorporated DPM determined by scintillation spectroscopy (Packard). For the  $\beta$ -radiation treatment and thymidine uptake assay the same technique was used except that 96 well plates were used, the wells were seeded at density of 2500 cells/well (7500 cells/cm<sup>2</sup>) wells and pulsed with 0.5  $\mu$ Ci per well.

## **2.55 Trypan blue uptake**

Fibroblasts were seeded onto eight 96-well plates (Sterilin) at a density of 5000 cells per cm<sup>2</sup> and allowed to settle for one day. Each plate was divided into 12 groups

of four wells which were treated with different concentrations of 5-FU in DMEM/10% FBS; 0, 1 and 100  $\mu\text{g}$  per ml for different periods of 1, 3, 6 and 12 days. At days 0, 1, 3, 6, 12, 18, 24 and 30, one plate was taken and each well in turn filled with a concentration of 0.25% trypan blue/DMEM. After one minutes' incubation, the number of trypan blue positive cells were counted in each of five fields and an average calculated. The well was then washed gently with HBSS, fixed with methanol and the number of cells in each of five fields counted. The percentage of trypan blue positive cells was calculated using the formula:

$$\frac{\text{Average number of trypan blue positive cells}}{\text{Average total number of cells after fixation}} \times 100$$

## 2.6 Pharmacokinetics of subconjunctival sodium butyrate in the eye

The pharmacokinetics of an subconjunctival injection were assessed using methods modified from previous studies by Rootman (Rootman et al, 1979; Rootman et al, 1984) and Fantes (Fantes et al, 1985) on 5-fluorouracil. One mCi of  $^3\text{H}$  labelled sodium butyrate (Amersham) (67 mCi/mmol) was diluted in double distilled water. This was diluted in a 200mM solution of sodium butyrate in double distilled water to a final radioactivity of 1  $\mu\text{Ci/ml}$  of sodium butyrate solution. A 200 mM concentration was chosen as this was 100 times greater than the concentration required to inhibit cellular proliferation *in vitro*. Previous pharmacokinetic studies have shown that an initial injection concentration about 100 times greater than that desired is required to achieve therapeutic concentrations for several hours (Rootman et al, 1979; Rootman et al, 1984; Fantes et al, 1985).

Pigmented rabbits, weighing 2-3 kg were anaesthetised with an intramuscular injection of ketamine 50 mg/kg and xylazine 10 mg/kg. A subconjunctival injection of 0.2 ml was given using a 27 gauge needle on a 1 ml syringe to the right eye of each animal. Animals were sacrificed at 0.5, 3, 6 and 24 hours. Three animals were used for each volume of injection at each time point. At the appropriate time points, the animals were reanaesthetised and approximately 100  $\mu\text{l}$  of aqueous humour taken from each eye. The animals were then sacrificed with an intracardiac injection of 2 mls of pentobarbital 100 mg/ml. The eye was enucleated with a large conjunctival fringe. Samples were then dissected out including conjunctiva, cornea and sclera. These samples were placed in preweighed scintillation vials, which were weighed again to

ascertain the weight of the individual samples. 0.2 ml of the original  $^3\text{H}$  solution were also used a control and a reference standard. The vials were digested overnight for 18 hours with tissue solubiliser (Packard), and then 10 ml of scintillation fluid (Packard) was added and the vials counted in a scintillation counter (Packard 1900-CA). The counts per milligram of tissue were calculated and expressed as a percentage of initial total counts.

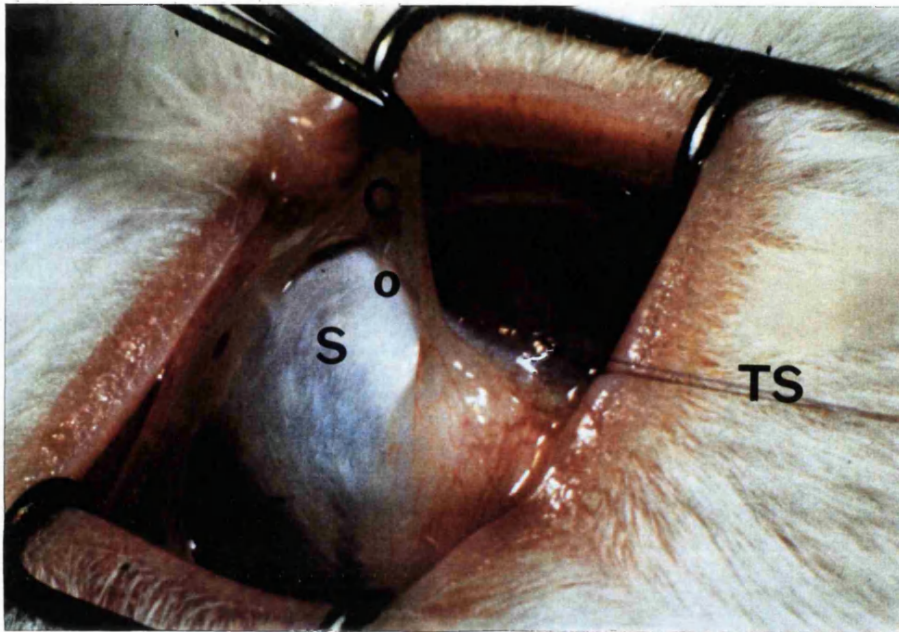
## **2.7 Experimental model of filtration ("fistulising") surgery**

### **2.71 Operative design and technique**

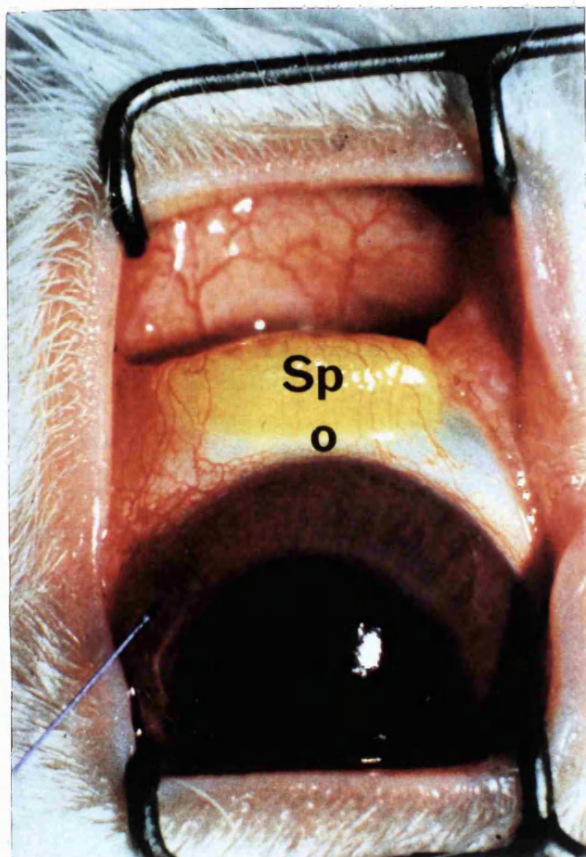
A prospective, randomised, placebo- controlled, masked observer study was performed using New Zealand white albino rabbits weighing between 2 and 4 kilograms. Prior approval of the experimental protocol was obtained from the Home Office (UK) under the Animal Procedures Act, and subsequently from the University of Florida Institutional Animal Care and Use Committee. In addition, all animal subjects were treated in accordance with the ARVO resolution on the use of animals in research.

A posterior lip sclerostomy was performed on the right eye of each animal. General anaesthesia was induced with an intramuscular injection of ketamine 50 mg/kg and xylazine 10 mg/kg. A partial thickness 8/0 silk corneal traction suture was placed superiorly and the eye pulled down (**Figure 17**). A limbus based conjunctival flap was then raised. Any animal with a conjunctival buttonhole was excluded prior to randomisation. The remaining rabbits were randomly allocated to one of four intraoperative treatment groups. Group 1 (10 rabbits) was a control group and received distilled water, group 2 (10 rabbits) received 5FU, group 3 (10 rabbits) and group 4 (9 rabbits) were treated with 0.2 mg/ml and 0.4 mg/ml concentrations of mitomycin-c respectively. The 5FU used was the same preformulated solution available from the manufacturer for subconjunctival injections (Roche). The mitomycin-c was obtained from the supplier (Bristol-Myers) as a powder and dissolved in the appropriate volume of distilled water to obtain the two concentrations. The MMC solutions were used within eight hours of reconstitution. A sponge measuring 4 x 1 mm cut from a Weck-Cel (Weck) was soaked in either distilled water, 5-FU (Roche) 50 mg/ml, mitomycin-c (Bristol-Myers) 0.2 or 0.4 mg/ml. The sponge was then placed between the conjunctiva and sclera over the planned filtration site for a minute and this was repeated four times with freshly soaked sponges for a total of five minutes of

**Figure: 17** Operative technique for single treatments with distilled water, 5-FU 50 mg/ml and MMC 0.4 mg/ml.



**Initial dissection.** The eye was positioned with a corneal traction suture.(TS) The conjunctiva (C) was opened in the upper fornix.(F) It was dissected off the underlying sclera (S) up to the limbus.(L) o = site of eventual sclerostomy "fistula".



**Treatment of subconjunctival and scleral tissues**

A sponge (Sp) containing either distilled water, 5-FU 50 mg/ml or MMC 0.4 mg/ml was placed in the space between the conjunctiva and sclera (stained in this picture with fluorescein for illustrative purposes). It was replaced every minute for five minutes, and then the area was washed out with 20mls of balanced salt solution. A drainage channel between the anterior chamber and the subconjunctival space was then created using a standard punch. The conjunctiva was then closed with a continuous Vicryl suture.

o = site of eventual sclerostomy "fistula".

tissue exposure. The area was then thoroughly irrigated with 20-30 ml of balanced salt solution (BSS) (Alcon) before entering the eye to avoid anterior chamber toxicity.

A limbal incision 2mm long was made and the anterior chamber entered. A 1.5mm Gass scleral punch (Storz) was used to remove a standard sized block of tissue from the posterior part of the incision area. A peripheral iridectomy was then performed through the sclerostomy. The conjunctival incision was closed with a running 8/0 vicryl suture on a B/V 130-4 needle. A paracentesis was performed with a 30 gauge needle and BSS was injected into the anterior chamber to confirm the presence of a patent sclerostomy and to inflate a bleb. The conjunctival incision and bleb were inspected to ensure there was no leakage. One drop of atropine sulphate 1% (Alcon) and dexamethasone and neomycin ointment (Alcon) were instilled at the end of surgery, with no further post operative medications.

## **2.72 Assessment of intraocular pressure and bleb grading**

All post operative observations were made by an observer masked to which intraoperative treatment these rabbits received. Intraocular pressure was measured and the bleb appearance graded. These observations were made on days 1, 3, 5, 7 and then twice a week until day 30. The animals were examined twice weekly with fluorescein and a cobalt blue light for the presence of corneal staining or bleb leak. Pressure readings were obtained using a Tono-pen<sup>r</sup> (Biorad), after anaesthetizing the cornea with 1% proxymethacaine (Alcon). The lids were gently held open without the use of a speculum. The intraocular pressure IOP recorded was the mean of the first two readings within 2 mmHg of each other that achieved the 5% level of reliability. Bleb size was graded as none (0), low (1), moderate (2) or high (3).

Statistical analyses were performed to determine whether responses differed between the four groups. Primary endpoints for analysis included IOP, time to IOP failure, bleb appearance, time to bleb failure and complication rates. For all analyses, a p value less than 0.05 was considered statistically significant. To evaluate differences in IOP values between the four groups, analysis of variance was used. One way analysis of variance was carried out at each time point to determine whether statistically significant differences existed between the groups. If a difference was observed, Fisher's least significant difference multiple comparison procedure was used to determine which groups differed (Milliken and Johnson, 1984). Bleb appearance was analysed in a similar fashion, except Kruskal Wallis and rank sum tests were

performed, due to the ordinal nature of the data (Lehmann, 1975). Survival analyses were carried out for IOP failure and bleb failure. The IOP failure time was defined to be the time at which IOP equalled or surpassed the baseline value. The date that bleb appearance was first coded as zero was used as the bleb failure date. For the survival data, standard log-rank tests were used to test for overall survival differences between the four groups. If differences were detected, pairwise tests were used to determine which groups differed (Kalbfleisch and Prentice, 1980).

## **2.73 Histology**

Eyes were fixed in 10% neutral buffered formalin (Buffered Formalin-Fresh 10% Formalin, Fisher Scientific) for 24 hours. They were then transferred into processing cassettes (Tissue-Tek Unicassettes, Baxter Scientific Products), and the cassettes were carried through the dehydration, clearing and infiltration steps by an automatic processing machine (AutoTechnicon Processor Model 2A, Technicon). The steps were all one hour in length, in the following order:

- 1) Ethanol: twice at 70%, twice at 95%, and three times at 100%, to dehydrate the specimen.
- 2) Toluene: twice at Room temperature, to wash out ethanol which is non-miscible with paraffin.
- 3) Paraffin: twice, to wash out the toluene. This was done using paraffin which melts at 56°C.

The cassettes were then put into the paraffin bath of an embedding console (Tissue-Tek Embedding Console, Miles Scientific) for about 30 minutes. After removal from the cassettes, the tissue was oriented in molds, and embedded in paraffin (Amerifin Tissue Embedding Medium, Baxter Scientific Products). The blocks of paraffin were shaved down with the microtome blade (Reichert-Jung Biocut 2030 Microtome, Cambridge Instruments) until the correct area of tissue was found, then sections of 5 micron thickness were taken and mounted on saline-coated slides. The sections were stained with Haematoxylin and Eosin and also the Lillie modification of Masson's trichrome staining procedure (Bancroft and Cook, 1984), with the change of reducing the time in Fast Green to two minutes. Haematoxylin and Eosin were used to show up cellular nuclei, and Masson's trichrome was used because it identified early granulation tissue well. They were then covered with glass cover slips (Arnold and Horwell) and viewed under a light microscope (Vickers ML 1300, Vickers Instruments).



## **2.8 Fibroblast tissue outgrowth assay**

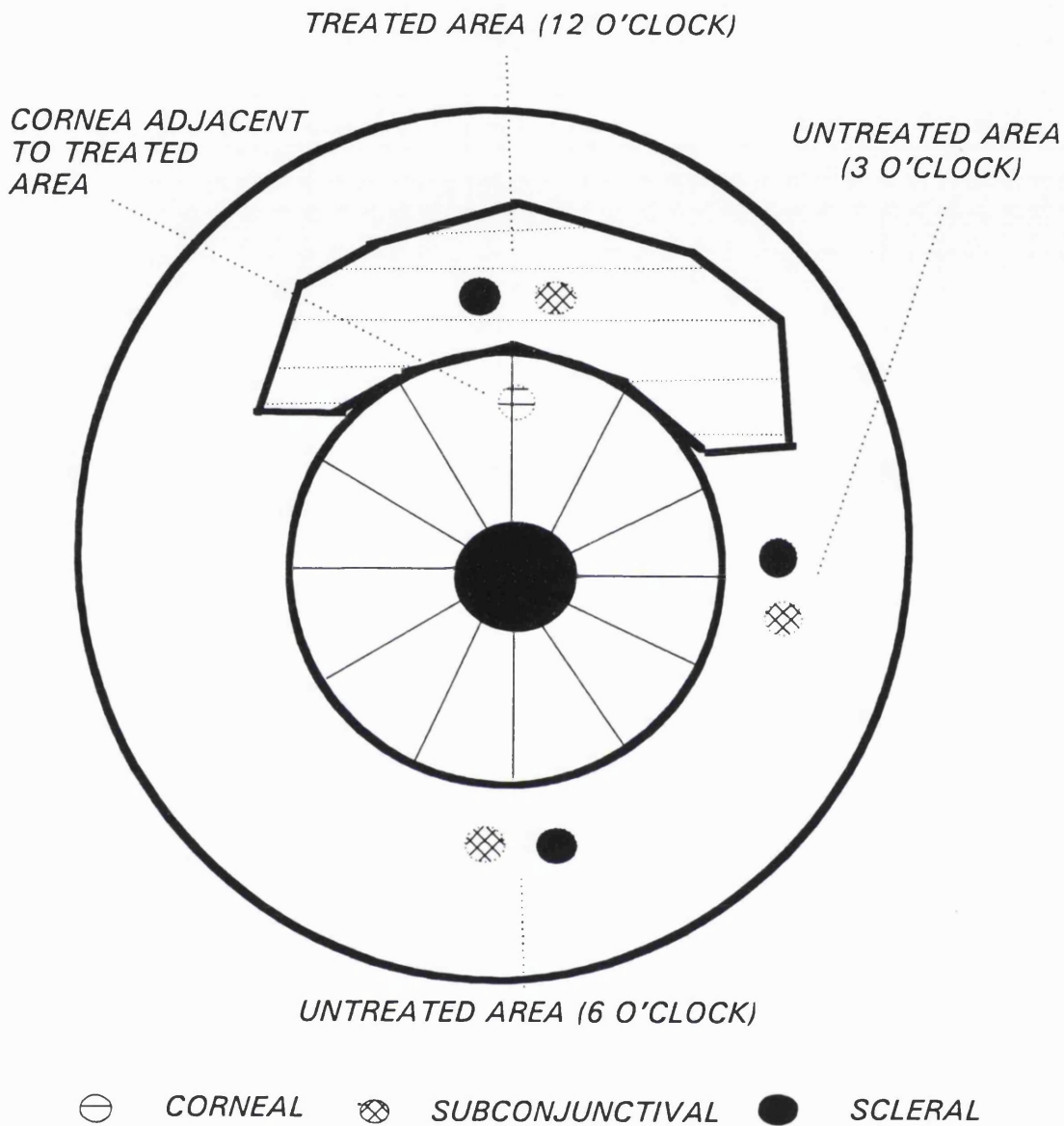
### **2.81 Tissue Biopsy technique**

A total of 36 rabbit eyes were treated with intraoperative water or antiproliferative treatment as outlined above. One hour, five days and 30 days after surgery, four animals were sacrificed with pentobarbital and samples of subconjunctival and scleral tissue were taken from the treated area, 90 degrees (3 o'clock position), and 180 degrees (6 o'clock position) from the center of the intraoperative treatment site (**Figure 18**). Samples were also taken from the cornea (after gently scraping off epithelium and endothelium) 2mm adjacent to the treated area one hour and five days after surgery. The samples were obtained by outlining the biopsy with a 2mm trephine (Storz) and gently dissecting out the piece of tissue. Each biopsy was placed in a single well of a 24 well plate (Costar) under a circular cover slip (Fisher) which was fixed down in a corner with wax. Great care was taken in handling the biopsies, in particular to ensure that the samples did not dry out and affect cellular viability. The wells were then filled immediately with Trimix media (DMEM\F-12\M-199\Hepes buffer) (Gibco) with 20% fetal calf serum (Gibco) and incubated at 37° C in a humidified atmosphere. Trimix media was used as it gave a more optimal outgrowth of cells compared to any single media alone, and the intention in this assay was to optimise outgrowth. The media was exchanged in each well every three days for 15 days.

### **2.82 Explant outgrowth culture and quantification**

The fibroblast outgrowth from each sample was quantified by measuring the length of fibroblast outgrowth using a grid (Southern Scientific instruments) placed in the eyepiece of an inverted phase microscope (Nikon ZM). The length of outgrowth was measured in four quadrants at 0, 90, 180 and 270 degrees around the tissue explant at x 40 magnification. An average outgrowth length was then calculated for each explant on each day from these four readings. These measurements were repeated every three days for 15 days for each biopsy. The results from four separate eyes were used for each of the three treatments, for each time point. The cell outgrowths were also photographed using generic 160 ASA Tungsten slide film (E6 process) regularly and any abnormal fibroblast morphology was noted.

**Figure 18** Diagram of sites of tissue samples taken for explant outgrowth experiment.



Samples of subconjunctival and scleral tissue were taken from the treated area, 90 degrees (3 o'clock position, approximately 2 mm from the edge of the treated area), and 180 degrees (6 o'clock position) from the center of the intraoperative treatment site. Samples were also taken from the cornea (after gently scraping off epithelium and endothelium) 2mm adjacent to the treated area one hour and 5 days after surgery. Each biopsy was placed in tissue culture and the outgrowth quantitated.

Statistical analysis was performed to ascertain any differences in outgrowth between the groups at different days of the experiment. Repeated measures analysis of variance was performed at each time point. When significant differences were found, Fisher's least significant difference comparisons were carried out to determine where differences were located. Significance was defined as  $P < 0.05$ .

## **2.9 Fibroblast RNA levels after growth factor treatment**

### **2.91 Cell treatment with TGF- $\beta$ 1 or growth arresting concentrations of 5-fluorouracil.**

Human Tenon's capsule fibroblasts were passaged into three 150 cm<sup>2</sup> tissue culture flasks and were used in the preconfluent state. Three of the six flasks were treated for a day with 5-fluorouracil 100  $\mu$ g/ml/DMEM/10% FCS to induce growth arrest. The other three flasks were kept in DMEM/10% FCS. The cells were then rinsed gently three times with Hank's balanced salt solution and the media replaced with serum free DMEM for 36 hours to synchronise the cells and optimise the chance of detecting differences in RNA levels by reducing serum stimulation to a minimum. 1% bovine serum albumin was dissolved in serum-free DMEM, filter sterilised and sterile recombinant TGF- $\beta$ 1 (Chiron) was dissolved in this solution to make up concentrations of 0, 5 and 500 pMolar. The cells were then exposed to transforming growth factor- $\beta$ 1 at concentrations of 5 and 500 pMolar, concentrations previously established as optimum for eliciting a response to TGF  $\beta$  (Igotz et al, 1987). After 48 hours of treatment, the cells were processed for RNA. The cells were monitored by phase contract microscopy (Nikon Diaphot, Nikon) to ensure that no overt cell death or toxicity was occurring, due to the serum free period or any of the growth factors or albumin.

### **2.92 RNA extraction and quantification**

A method for RNA extraction was used based on the method of Chirgwin (Chirgwin et al, 1979). All glassware and solutions were either treated with 0.2% Diethylpyrocarbonate (DEPC)(Sigma) in double distilled water (DDW) and autoclaved or baked at 150°C for four hours (Sambrook et al, 1989). The culture medium was poured off the fibroblasts. The cells were then washed once with Hanks BSS at 4°C. Two mls of 4 Molar guanidinium isothiocyanate (Guanidinium isothiocyanate 4 Molar,

sodium citrate pH 7, 25 mM, Sarkosyl 0.5% and  $\beta$ -mercaptoethanol 0.1 Molar)(all Sigma) was then added to each flask. The flask was placed on a rotating plate to spread the solution over the monolayer. When all the cells were observed to be disrupted, the solution was then poured into an RNase-free vial and the DNA sheared by passing it several times through a 22 gauge needle to reduce viscosity. This was then loaded onto 2mls of 6.2 Molar CsCl (CsCl 6.2 Molar Na<sub>2</sub>EDTA 0.1 Molar)(Fisher) in RNase-free cellulose nitrate tubes (Nalgene) in a SW 50.1 rotor. The tubes were then spun at 35,000 rpm for 15-18 hours at 20°C in a Beckman Ultracentrifuge (Beckman). The supernatant was aspirated leaving a layer of 1-1.5 cm of CsCl. The walls of the tube were very gently rinsed with GTC (3 x 0.5 ml) keeping the RNA pellet covered with a CsCl layer. The tube was then inverted discarding the CsCl leaving behind the RNA pellet. The bottom of the tube was cut off and the pellet rinsed with 80% Ethanol/20% DEPC treated water. The pellet was resuspended in 200  $\mu$ l of DEPC treated water and 8  $\mu$ l of 5M NaCl was added with 500  $\mu$ l of ethanol to precipitate the RNA. The purity and quantity of RNA was established after measuring the OD 260/280 ratio using a Spectrophotometer (Beckman).

### 2.93 P<sup>32</sup> cDNA Probe preparation

Radiolabeled probes were made using 25  $\mu$ g of the appropriate DNA using a random primer DNA labelling system as outlined by Feinberg and Vogelstein (Feinberg and Vogelstein, 1983). The DNA template for the radiolabelled probe (25  $\mu$ g) was dissolved in 10  $\mu$ l of dilute buffer (0.67 Molar Hepes, 0.17 Molar Tris-HCL, 17 mMolar MgCl<sub>2</sub>, 33 mM 2-mercaptoethanol, 1.33 mg/ml BSA, and 18 OD<sub>260</sub> units/ml of oligodeoxyribonucleotide primers (hexamer fraction), pH 6.8). This mixture was heated to 95°C for 5 minutes and then immediately cooled on ice. The 15  $\mu$ l of buffer mixture, 2  $\mu$ l of dATP, dGTP and dTTP, 5  $\mu$ l (50  $\mu$ Ci) of  $\alpha$ -<sup>32</sup>PdCTP 3000 Ci/mmol, 10  $\mu$ Ci/ $\mu$ l and distilled water to a total volume of 49  $\mu$ l were added and mixed. One  $\mu$ l of Klenow Fragment (Large fragment of DNA polymerase I 3 units/ $\mu$ l in 100mM potassium phosphate buffer pH 7.0, 10 mM 2-mercaptoethanol, 50% v/v/ glycerol) was then added and the mixture centrifuged for a few seconds. The mixture was heated to 25°C for one hour. Five  $\mu$ l of stop solution was then added.

The P<sup>32</sup> labelled probe was isolated by passing the mixture through a resin column to trap the unincorporated nucleotides (Stratagene), after mixing with blue dextran and crocein orange to monitor progress of different size molecules down the column. The blue fraction was collected and counted in a gamma counter. Probes used included

Collagen I2 $\alpha$  in pBr322 cut with EcoR1 to give 3.55 Kb (American Type Culture Collection (ATCC) 57322), Lysyl oxidase in pUC18 cut with EcoR1 to give a 0.656 Kb (kindly provided by Dr Thomas Yang, University of Florida, unpublished), TGF $\beta$ 1 in pBR327 cut with EcoR1 to give an insert of 2.14 Kb (ATCC 59954 Ardinger et al 1988 Kasid et al 1988), Copper Zinc Superoxide dismutase (Cu Zn SOD) in pUC19 (Courtesy of Dr Harry Nick, University of Florida, unpublished) cut with EcoR1 to give 0.620 Kb insert.

## **2.94 Preparation of samples and RNA gel electrophoresis and blotting**

Fifty  $\mu$ g of total RNA was removed from the storage eppendorfs and centrifuged for 30 minutes at room temperature at 14K rpm in a microcentrifuge. In addition, a 0.24-9.5 Kb RNA ladder (Gibco) was run simultaneously. The ethanol was poured off and the pellet air dried until all EtOH was gone. To each sample was added 12.5  $\mu$ l formamide dye, 4.5  $\mu$ l formaldehyde, 2.5  $\mu$ l 10 x MOPS buffer (0.4 M 3-[N-morpholino]propanesulphonic acid, 0.1 M sodium acetate, 10mM EDTA), and 5.5  $\mu$ l DEPC treated water for a total of 25  $\mu$ l. This sample was mixed well by pipetting before being placed in a 65°C water bath for 15-20 minutes. During the incubation, the sample was mixed gently at least twice more. The tubes were then placed on ice to prevent reassociation of secondary structure of RNA.

To make the gel, three grams of agarose were added to 216 ml of DEPC treated water and microwaved on high setting (Phillips) until boiling and all the agarose had melted. The agarose was gently swirled until it cooled to 65°C., using combs (BRL thin combs) with 20 wells. Then 30ml of 10 x MOPS and 54 ml 37% formaldehyde (Fisher) were added. The mixture was poured into a levelled casting tray in the fume hood, with thin 20 well combs already in place (Biorad). Just before loading the gel, the wells were gently rinsed with 1X MOPS buffer to remove bubbles and debris. The samples were loaded into the 300 ml 1% agarose/formaldehyde gel, prepared as described above. A CP Masterflex pump was used to circulate the buffer. The gel was run at about 40 V for 16-24 hours or until the dye front had travelled at least 12 cm (or more, depending on the required separation of bands). The main gel was then cut and soaked in 20 x SSC (Saline-sodium citrate buffer) for 30 minutes, and this was repeated with fresh 20 x SSC for 30 minutes (to rinse out excess formaldehyde).

A wick was made with Whatman 3mm Chromatography paper and soaked in 10 x SSC. The gel was measured and a nylon membrane (Hybond N+) was cut with an additional 1 cm on each side. The nylon membrane was soaked submerged for 5

minutes in 10 x SSC taking care not to expose the membrane to water or skin. Two pieces of Whatman 3mm paper were cut slightly larger than the membrane. One was soaked in 10 x SSC and placed on top of the membrane. The other dry Whatman 3mm paper sheet was placed on top of the wet one. Paper hand towels to a height of 10 cm were then layered on top and a heavy baking dish placed on top, with 500gm of additional weight. The RNA was then allowed to transfer overnight for 18 hours. The membrane was dried by blotting on Whatman 3mm paper. The blot was placed between two pieces of Whatman 3mm paper and placed in a vacuum oven at 80°C for 30 minutes, and then stored at room temperature. The blot was washed for 10 minutes at 65°C in 0.1X SSC/0.5% SDS.

### **2.95 Northern blot prehybridisation and hybridisation**

The blot was prehybridised in a solution of 5 x SSC, 5 x Denhardt's solution, salmon sperm DNA 100 µl/ml, 0.5% SDS, and formamide 40%, which was heated for 15 minutes at 95°C to denature the DNA. The solution was added to the blots in sealed plastic bags (Seal-a-meal bags) after rolling out bubbles. The blot was left for 18 hours overnight at 42°C in a swirling water bath. The hybridization solution was made by mixing 2g dextran sulphate, 8 ml formamide, 2 ml DEPC double distilled water and 5 mls of 20 x SSC. This solution was left overnight for 18 hours at 42°C to allow the dextran sulfate to go into solution in a rotating incubator. Then the following components were added 5ml 20 x SSC, 200 µl Denhardt's solution, 0.4 ml of salmon sperm (after denaturing for 15 minutes at 95°C), 500 µl of 20% SDS and 8 ml of formamide to make a final concentration of 5 x SSC, 1 x Denhardt's, 100 µg/ml Salmon sperm DNA, 0.5% SDS and 40% formamide. DEPC-treated DDW was used to bring this volume up to 20 ml. The hybridization solution was prewarmed to 42°C, and the denatured probe (heated for 10 minutes at 95°C) added to the 50 ml tube with hybridization solution. Gentle mixing was carried out and the hybridization solution was then added to the bag with the blot that had prehybridised overnight. Bubbles were rolled out, the first bag sealed in a second bag. The bags were incubated at 42°C for 18 hours overnight in an agitating water bath.

### **2.96 Washing and autoradiography**

After incubation, the hybridization solution and radioactive probe were carefully removed from the bag into the radioactive waste container. The blot was removed and

placed in wash solution (2 x SSC/0.1% SDS) for 30 minutes at room temperature. This was then repeated again for 30 minutes. The blot was then placed in a solution at 65°C in water bath shaker for at least 30 minutes. Radioactive emissions were monitored using a Geiger counter. If the corners had no background counts, washing was stopped. Otherwise, a solution of 1 x SSC/0.1% SDS at 65°C was used to continue the washing process, and stopped when background radioactivity in the corners was sufficiently low. The membrane was blotted dry, placed in plastic cling film and stuck into an X-ray plate holder (Fisher) on the inside of two intensifying screens. X ray film (Kodak Xomat) was then placed alongside the blot in a dark room and exposure carried out for a variable period of at least 12 hours depending on the amount of radioactivity present on the blot. The X-ray film was developed on a film developing machine (Kodak).

## **2.97 Quantitation**

The autoradiographs were placed on a X-ray transillumination box (Wardray) and the image captured using a very high resolution camera (Sony XC-77 CCD, Sony Corporation) and a Microscale™ transputer based image analysis card (Digihurst), and analysed using Microeye™ image analysis software (Digihurst). The density and area data were integrated to calculate the density/volume of each blot. This was then divided by the Cu Zn SOD blots, which acted as loading controls. The relative increase in RNA level was calculated by dividing the ratio of the 5pM or 500pM treatments by the 0 pM ratio.

## CHAPTER 3 RESULTS

### 3.1 Fibroblast cell culture

After the pieces of Tenon's capsule were placed under cover slips in FCS and DMEM they were left in the incubator at 37<sup>0C</sup> for two weeks. Outgrowth of fibroblasts were usually noted between one and two weeks, and the flask usually became confluent after three to four weeks (**Figure 19**). Cells growing out of the explants usually had a thin spindle shape cell appearance, and these cells only began to display a larger cytoplasmic volume when they reached confluence. During the period of pre-confluence, many of the cells had obvious mitotic figures. In addition to cells directly migrating out from the explant occasional satellite colonies were also found in other locations around the fibroblast which were presumably derived from cells which had attached at a point distant to the primary explant. On several occasions the fibroblast cell lines were immunostained with monoclonal antibody AE-5 (ICN Flow) which recognises a 64-kilodalton keratin found in corneal epithelial cells (Schermer et al, 1986). The fibroblast cell lines were always negative for this antibody in contrast to corneal epithelial cells grown separately which were always positive.

During passaging trypsin/EDTA was used, and cells were seen to round up after about 30 seconds to a minute, and eventually floated off into the media. After the cells were reseeded into new flasks they initially had a spherical shape but rapidly began to flatten and spread out on the new cell culture surface. They then assumed a relatively spindle like shape, until confluence was achieved within the flask. At confluence, they spread again but remained relatively spindle shaped. Although contact inhibition occurred at confluence, long periods at confluence resulted in some post confluent growth and some overlap of cells.

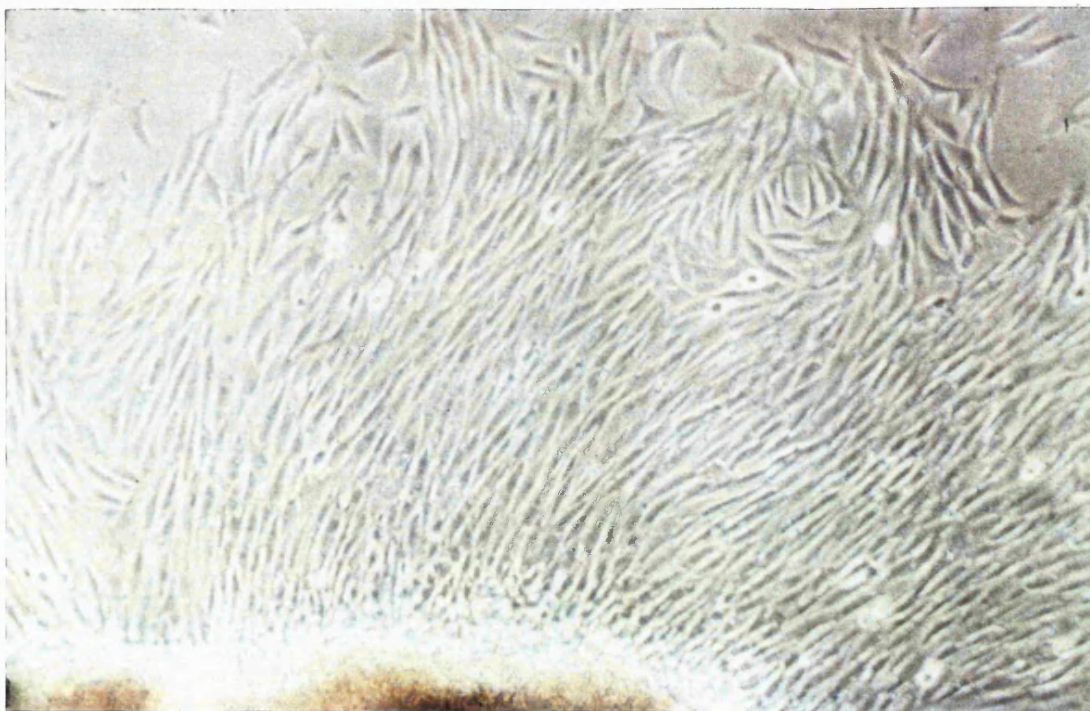
### 3.2 Migration of ocular fibroblasts to aqueous from patients with cataract, primary and secondary glaucomas

#### 3.21 Migration to aqueous

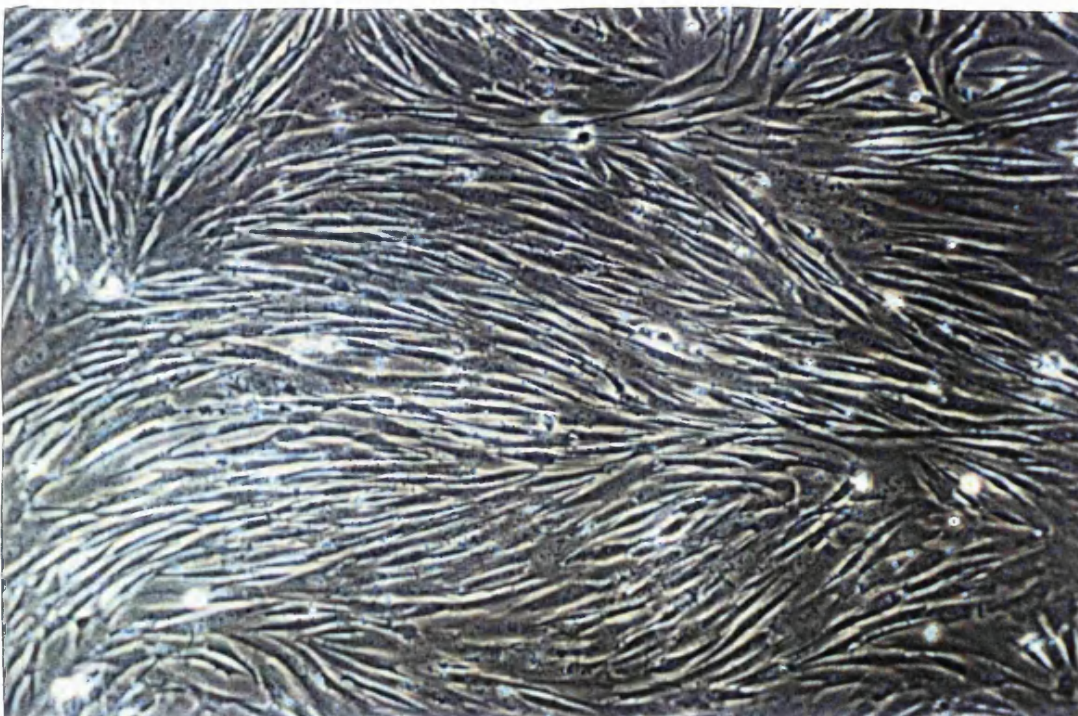
Migration was tested as it is a critical component of the healing process. Migration is known as a particularly sensitive monitor of fibroblast activation and responsiveness. In addition the aqueous samples were very limited, and only one biological assay could



**Figure 19** Tenon's capsule fibroblasts in culture.



Fibroblasts growing out from the edge of a piece of Tenon's capsule in a tissue culture flask after one week. Magnification X 100.



Confluent human Tenon's capsule fibroblasts after three weeks in culture. Magnification X 100.

be run on the available aqueous samples. A proliferation assay, even in 96 well plates, would have required much larger volume of aqueous, and it would not have been possible to do fibronectin assays simultaneously. A contraction assay, even in 96 well plates also requires a large volume of aqueous. The aqueous from patients with glaucoma and the controls stimulated migration of cells through the pores towards the chambers filled with 20% aqueous. In both groups, the number of cells migrated were significantly greater than media only. However, it was significantly less than the positive control of 10% foetal calf serum. There was no significant difference between the number of cells migrated in the control group ( $85.7 \pm 12.5$  SEM) compared with the glaucoma aqueous specimens ( $84.5 \pm 12.2$  SEM) (**Figure 20**). The stimulation of migration by aqueous appears to be primarily due to chemotaxis rather than chemokinesis, as assessed by the chequerboard technique (**Figure 21**).

### **3.22 Fibronectin levels in aqueous**

The ELISA for fibronectin was sensitive in the range  $0.7\mu\text{g/ml}$  to about  $4\mu\text{g/ml}$ . After preliminary assays, this range was found to cover the range found in the majority of aqueous specimens, particularly if serial dilutions were performed. The serial dilutions of aqueous were parallel with the standard curve suggesting that the assay was specific for fibronectin (**Figure 22**). The average level of fibronectin in the control aqueous specimens was  $1.31 \pm 0.10$  SEM and that in the glaucoma aqueous was  $1.92 \pm 0.24$  SEM which was statistically significant at the  $p > 0.01$  level (**Figure 23**).

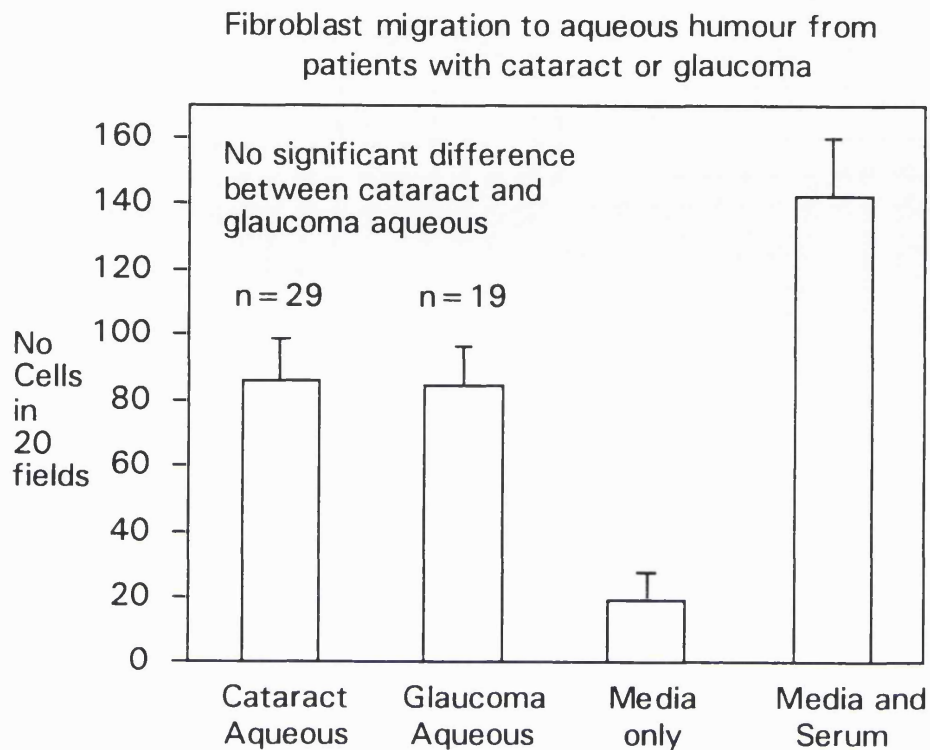
### **3.23 Correlation of migration and fibronectin levels**

The migration and fibronectin assays were performed on the same samples of aqueous and the results plotted against each other (**Figure 24**) and analysed using Minitab software (Minitab corporation) . The regression equation was  $x = 1.22 + 0.00386y$  where  $x$  = fibronectin level and  $y$  = number of cells migrated. However, the correlation coefficient was only 0.289 and this correlation was not statistically significant at the  $p < 0.05$  level ( $p = 0.12$ ).

### **3.24 Effect of fibronectin antibodies on the migration of fibroblasts to human aqueous humour**

The addition of polyclonal antibodies to fibronectin reduced migration to pooled

**Figure 20** Fibroblast migration to aqueous humour from patients with cataract or glaucoma



This graph shows the average number of cells migrated to aqueous from patients with cataract or glaucoma. There was no significant difference in the number of cells migrated to the aqueous in these two groups. The number of cells migrated was greater than media alone, but not greater than media with 20% serum, which was found to be the concentration of serum that resulted in the optimal number of fibroblasts migrated. Error bars = SEM.

**Figure 21 Chequerboard analysis of human Tenon's fibroblast migration to human aqueous humour**

<b>1) Control aqueous (cataract extractions)</b>					
		<b>Upper Chambers (with cells)</b>			
<b>% Aqueous Humour</b>		<b>0</b>	<b>5</b>	<b>10</b>	<b>20</b>
<b>Lower Chamber (No cells)</b>	<b>0</b>	<b>10 ± 1</b>	<b>23 ± 4</b>	<b>18 ± 3</b>	<b>20 ± 3</b>
	<b>5</b>	<b>41 ± 5</b>	<b>63 ± 2</b>	<b>49 ± 4</b>	<b>37 ± 2</b>
	<b>10</b>	<b>82 ± 8</b>	<b>85 ± 4</b>	<b>62 ± 3</b>	<b>40 ± 3</b>
	<b>20</b>	<b>107 ± 9</b>	<b>95 ± 10</b>	<b>95 ± 8</b>	<b>65 ± 5</b>

<b>2) Glaucoma aqueous</b>					
		<b>Upper Chambers (with cells)</b>			
<b>% Aqueous Humour</b>		<b>0</b>	<b>5</b>	<b>10</b>	<b>20</b>
<b>Lower Chamber (No cells)</b>	<b>0</b>	<b>14 ± 5</b>	<b>18 ± 2</b>	<b>15 ± 1</b>	<b>14 ± 1</b>
	<b>5</b>	<b>31 ± 2</b>	<b>68 ± 3</b>	<b>45 ± 3</b>	<b>29 ± 6</b>
	<b>10</b>	<b>80 ± 6</b>	<b>64 ± 3</b>	<b>59 ± 6</b>	<b>28 ± 3</b>
	<b>20</b>	<b>95 ± 10</b>	<b>85 ± 4</b>	<b>77 ± 4</b>	<b>57 ± 5</b>

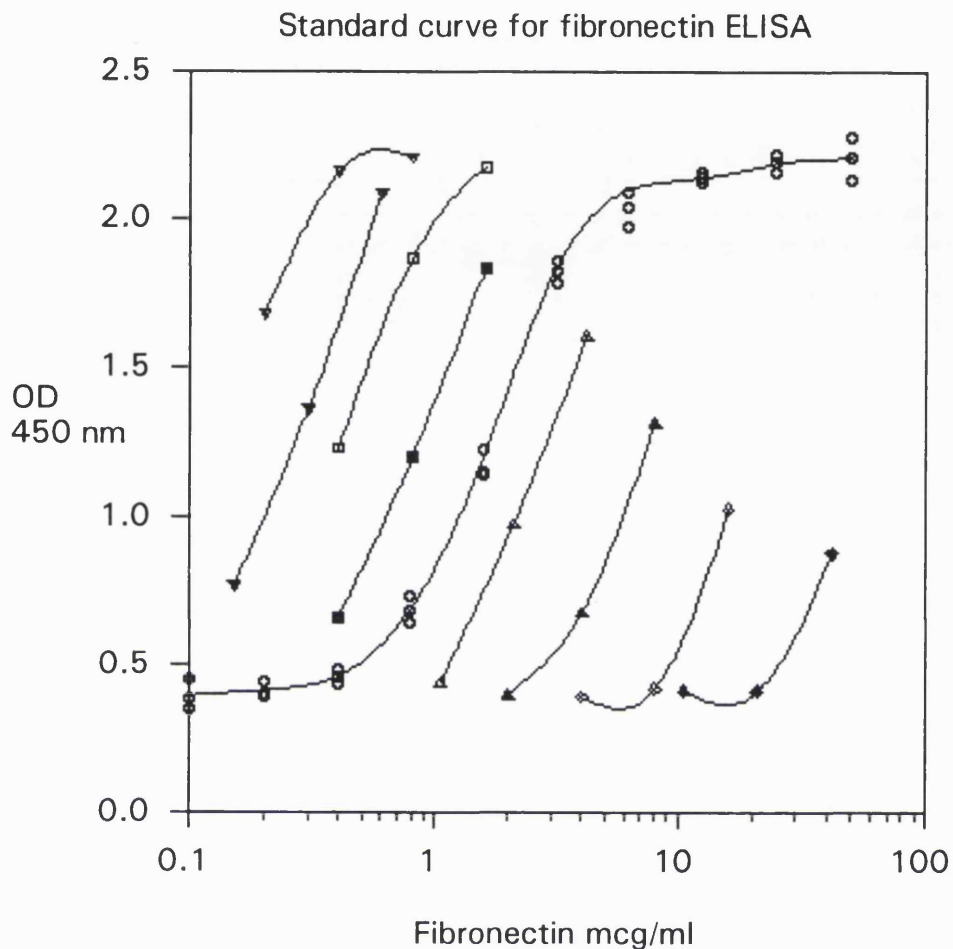
The upper chambers were filled with cells and the appropriate concentration of media and aqueous. The lower chambers were filled with the appropriate concentration of aqueous and media. Vertical axes represent the concentration of aqueous in the lower chambers without cells. Depending on the various combinations the cells have one of three gradients - higher, equal or lower concentrations of aqueous humour in the opposite chamber.

The top chequerboard is a representative sample of the control aqueous (eyes undergoing cataract extraction). Aqueous from a 67 year old man undergoing cataract extraction. The lower chequerboard shows the same experiment performed using aqueous from a 73 year old man with primary open angle glaucoma. Both aqueous samples show the same pattern:

- 1) A predominant chemotactic response, characterised by increasing numbers of cells migrating across the membrane towards the higher concentration of aqueous as the gradient increases. All of these increases are statistically significant as measured by one-way analysis of variance and Fishers least significant difference multiple comparison procedure.
- 2) A small chemokinetic response at lower concentrations of aqueous, characterised by an increase in the number of migrated cells as the concentrations of aqueous were increased by the same amount in both upper and lower chambers in equal steps. At the highest concentration (20% aqueous by volume) the number of cells migrated plateaued.

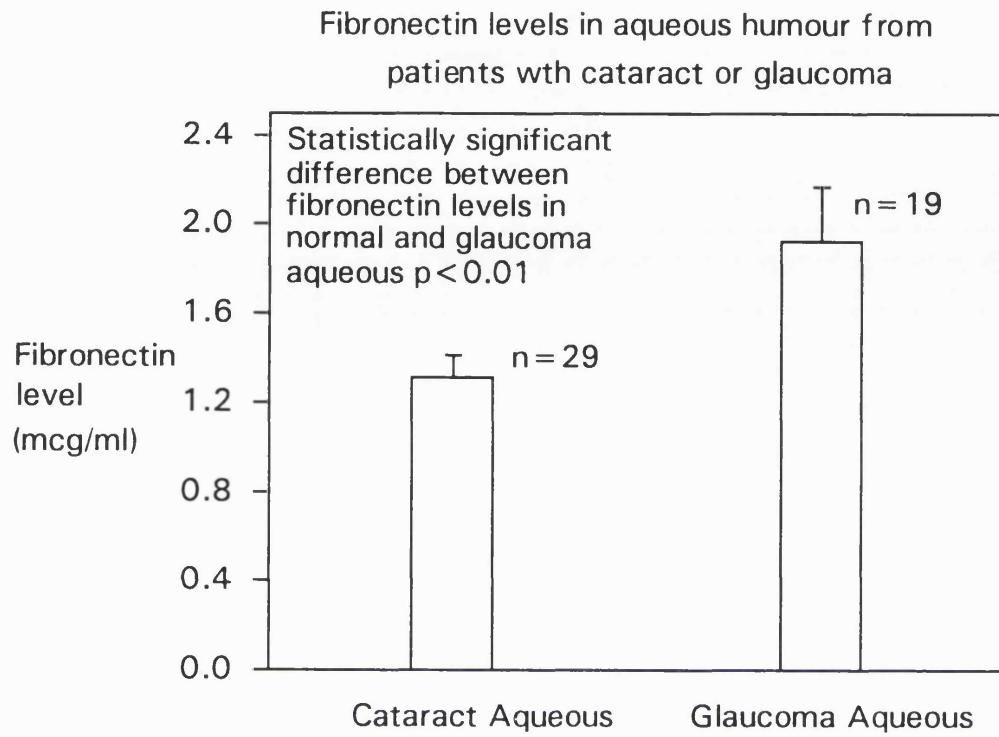
These results indicate that the migration to aqueous humour is primarily a chemotactic rather than a chemokinetic response. This pattern was the same with the other 6 samples tested (3 cataract controls and 3 glaucoma patients).

Figure 22 Standard curve for fibronectin ELISA



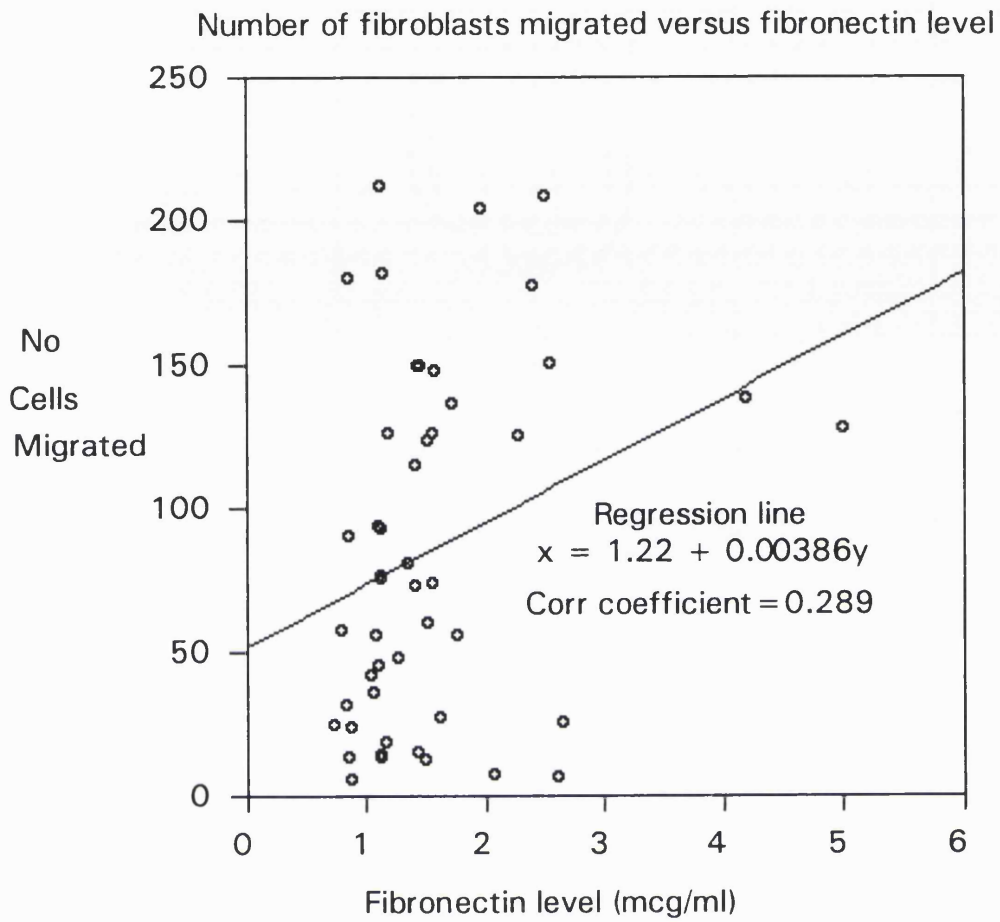
This figure shows the standard curve derived from a serial dilution of a standard 50  $\mu\text{g/ml}$  fibronectin solution. There were 3 samples per concentration. The results of serial dilutions of several aqueous samples are also shown. There is parallel displacement with the standard curve, indicating specificity of this assay for fibronectin in the aqueous humour.

**Figure 23** Fibronectin levels in the aqueous humour from patients with cataract or glaucoma



This graph shows the average fibronectin levels in the aqueous of patients with either cataract or glaucoma. There was a statistically significant difference in the average fibronectin levels in the aqueous from patients with cataracts and glaucoma. ( $p < 0.01$ ) The levels of fibronectin were lower in cataract aqueous. Error bars = SEM.

Figure 24 Number of fibroblasts migrated versus fibronectin level



This graph shows the fibronectin level in the aqueous against the number of cells migrated. There was no statistically significant correlation between the level of fibronectin in the aqueous and the number of cells migrated.

human aqueous humour from "normal" cataract controls, with a maximal reduction at an antibody concentration of 1:100. 1:100 was taken as a super maximal concentration as the effect of the antibody plateaued well before this concentration (**Figure 25**). However, the maximal reduction was only just under 16% of the migration (taking into account the background migration) at a 1/100 concentration. The antibody did not significantly inhibit background migration seen with DMEM. The antibody at a concentration of 1:100 reduced migration to a fibronectin solution of 5µg/ml by 78%. 5µg/ml was chosen as it is just above the average concentration of fibronectin human aqueous humour. This concentration was chosen to show that the fibronectin antibody could neutralise fibronectin at a concentration close to that found in human aqueous humour.

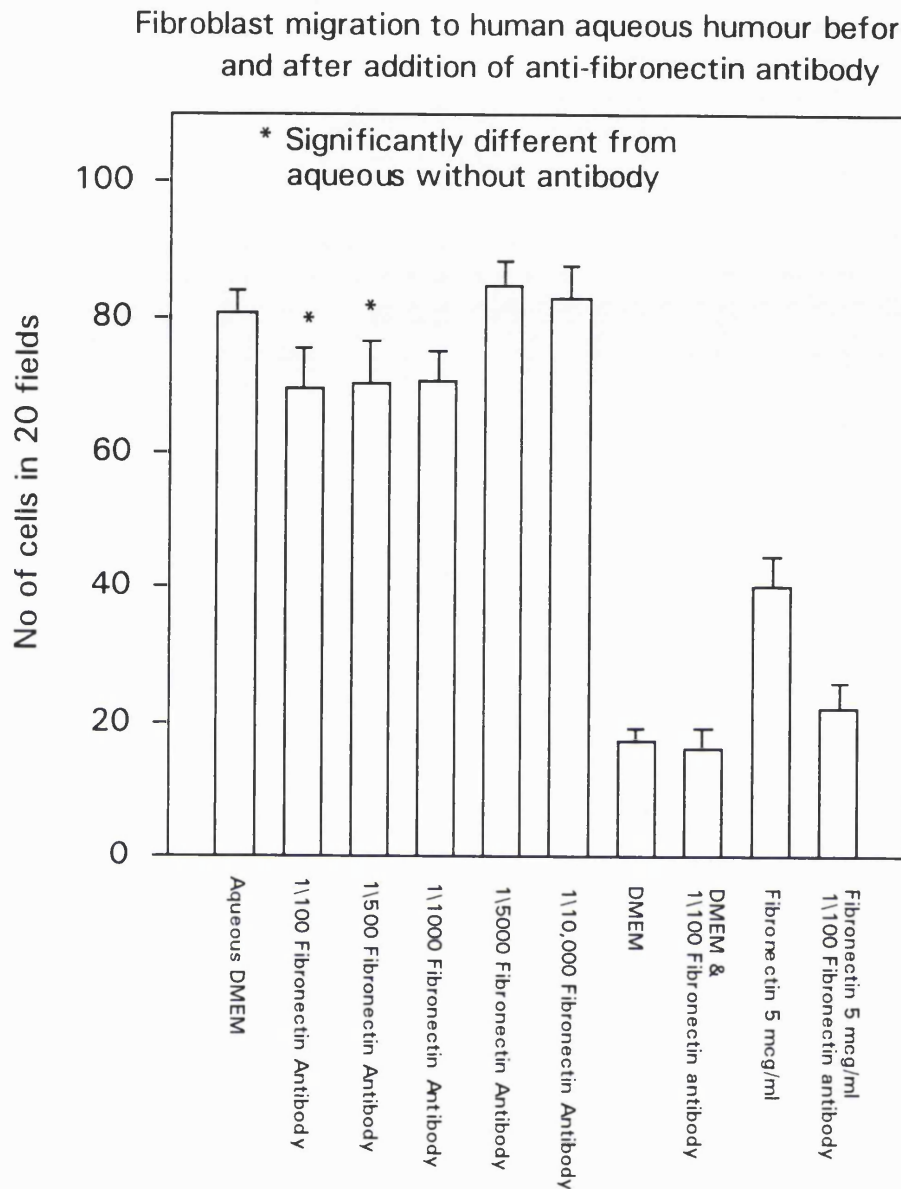
### **3.3 Effects of transforming growth factor β1 (TGF-β1), epidermal growth factor (EGF) and basic fibroblast growth factor (bFGF) on proliferation, migration and collagen production of ocular fibroblasts**

#### **3.31 Effect of growth factors on proliferation (<sup>3</sup>H thymidine uptake)**

The growth factors EGF, bFGF and TGF-β1 were used because they have been detected in human aqueous humour, and at the time of these experiments they were available commercially and their cost was not entirely prohibitive. All three growth factors stimulated an increase in thymidine uptake over the range 10<sup>-7</sup> to 10<sup>-14</sup> molar compared to control media (**Figure 26**). The upper limit of 10<sup>-7</sup> Molar was chosen as any higher concentrations were not thought to be present *in vivo*, and in addition the cost would have been prohibitive. However, both bFGF and TGF-β1 stimulated much greater absolute and relative (to serum free cells) increases in thymidine uptake compared with EGF. EGF at the optimum concentration only increased thymidine uptake 1.77 times (relative to serum free cells), whereas bFGF and TGF-β1 increased uptake 3.88 and 6.89 times. bFGF and TGF-β1 also increased thymidine uptake (1.06 and 1.75 times respectively) compared to the positive control of 20% foetal calf serum, whereas the thymidine uptake for EGF compared to 20% FCS was less (0.58). There was no obvious change in cell morphology between the fibroblasts treated with any of the three growth factors when the cells were monitored by phase contrast microscopy.



**Figure 25 Fibroblast migration to human aqueous humour before and after addition of anti-fibronectin antibody**

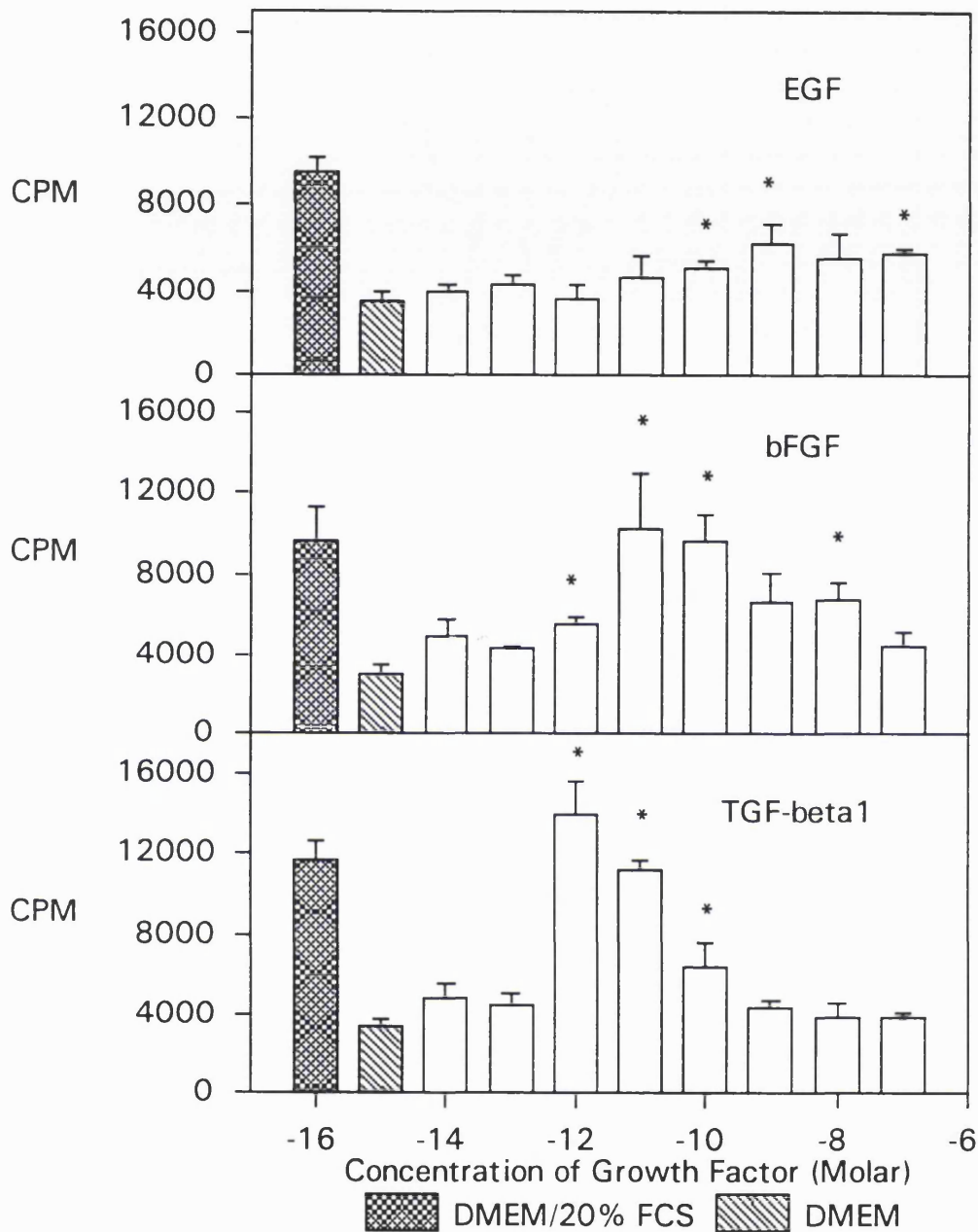


Graph showing fibroblast migration to human aqueous humour and fibronectin solution before and after treatment with different concentrations of fibronectin antibodies. Addition of fibronectin antibody to media alone did not significantly change migration, but addition of 1/100 fibronectin antibody to a 5 microgram (mcg) /ml fibronectin solution reduced the number of cells migrated to nearly the same as the media alone. This concentration of fibronectin was chosen as it was similar to aqueous levels.

Addition of antibody at various concentrations reduced migration compared to media plus aqueous, but this effect reached a plateau at 1/1000 and no longer increased at antibody concentrations of 1/500 and 1/100. A large number of cells still migrated to aqueous at maximal fibronectin antibody concentrations, suggesting that fibronectin was not the major chemoattractant in aqueous humour.

**Figure 26** Effects of growth factors EGF, bFGF, and TGF- $\beta$ 1 on ocular fibroblast proliferation ( $^3\text{H}$ -thymidine uptake)

Growth factors and ocular fibroblast proliferation ( $^3\text{H}$  thymidine uptake)



All 3 growth factors stimulated and increased  $^3\text{H}$ -thymidine uptake compared to control media. However bFGF and TGF- $\beta$ 1 stimulated greater increases of  $^3\text{H}$ -thymidine uptake compared to EGF. The maximal stimulation of proliferation occurred at a lower concentration of TGF- $\beta$ 1 ( $10^{-12}$  Molar). Error bars = SEM. \* = significantly different ( $p < 0.05$ ) from negative control of DMEM/BSA.

### 3.32 Migration (chemotaxis and chemokinesis) (modified Boyden chamber)

All three growth factors stimulated the migration of Tenon's fibroblasts (**Figure 27**). Although the peak stimulation occurred at different concentrations, the maximal stimulation compared to the serum free cells was considerably higher (8.52, 4.66 and 6.30 times greater for EGF, bFGF and TGF- $\beta$ 1 respectively). It is of interest that EGF stimulated a higher peak of migration than either bFGF and TGF- $\beta$ 1. All three growth factors also stimulated more migration than the positive control of 20% FCS (1.54, 1.36 and 1.23 times greater for EGF, bFGF and TGF- $\beta$ 1 respectively).

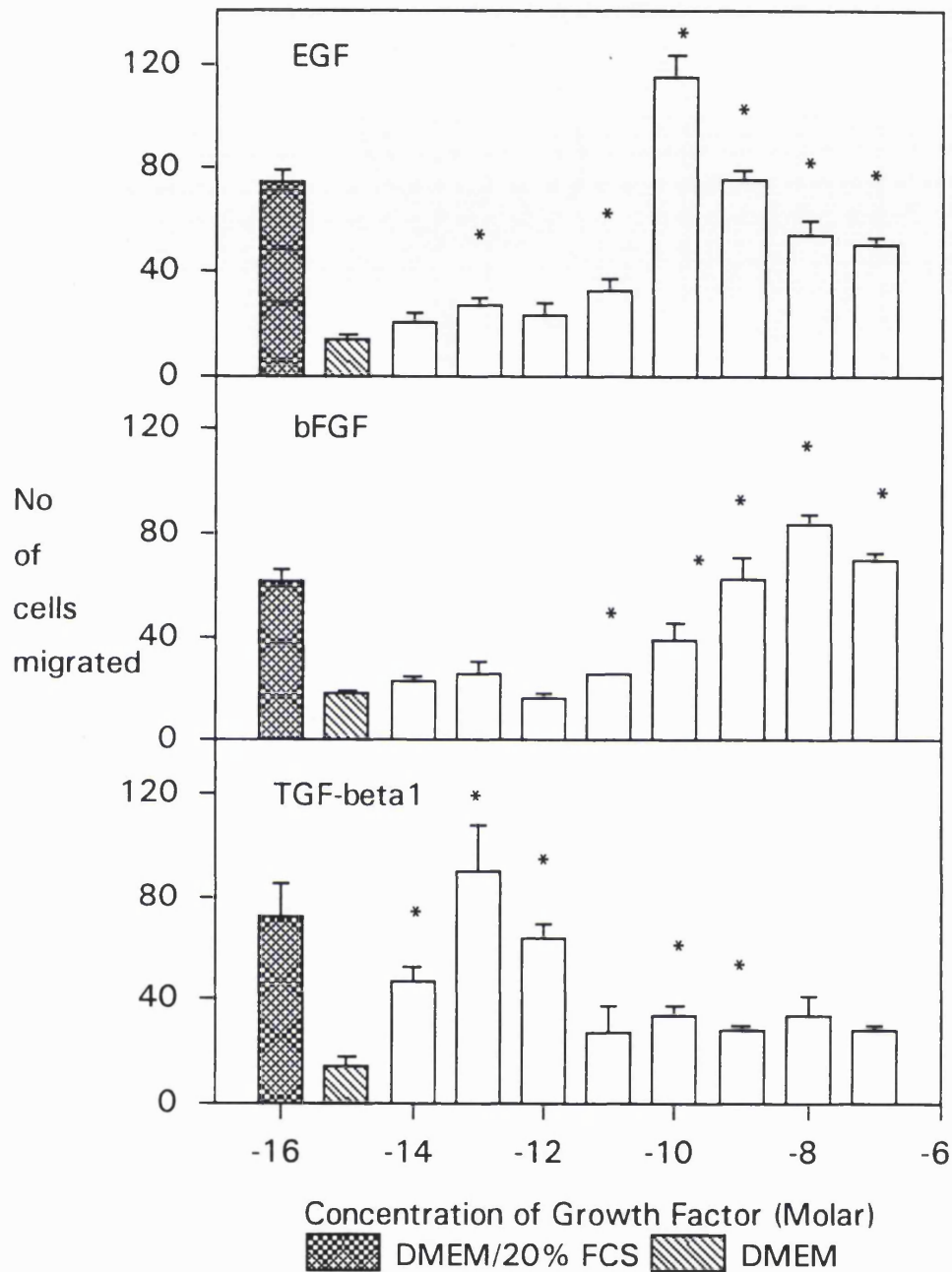
Chequerboard analysis of the fibroblast migration (**Figure 28**) induced by the various growth factors suggested that EGF and bFGF stimulate migration by stimulating both chemotaxis and chemokinesis. It appeared that chemokinesis was stimulated by these two factors as the numbers of cells migrated increased ( $28 \pm 4$  to  $77 \pm 9$ ) when the concentration of EGF was increased from 0 to 2 ng/ml in both upper and lower chambers. The numbers of cells migrated increased ( $12 \pm 4$  to  $62 \pm 9$ ) when the concentration of bFGF was increased from 0 to 160 ng/ml in both upper and lower chambers. However, the chemokinetic effect was smaller than the chemotactic effect for both these growth factors ( $123 \pm 14$  vs  $77 \pm 9$  for EGF, and  $105 \pm 4$  vs  $62 \pm 9$  for bFGF). In contrast, TGF- $\beta$ 1 appeared to stimulate migration primarily by stimulating chemotaxis. There was no increase in the number of cells migrating as the concentration of TGF- $\beta$ 1 was increased from 0 to 2.0 pg/ml in both the upper and lower chambers ( $24 \pm 3$  to  $22 \pm 3$ ), when tested using one-way analysis of variance.

### 3.33 Collagen production ( $^3\text{H}$ proline uptake)

All three growth factors stimulated an increase in  $^3\text{H}$  Proline uptake and incorporation into the collagen fraction (**Figure 29**). However, TGF- $\beta$ 1 (12.72 times) stimulated much more  $^3\text{H}$  proline uptake than EGF (5.37 times) or bFGF (4.29 times) compared to serum controls. All three growth factors stimulated less  $^3\text{H}$  proline uptake than 20% serum. The maximal stimulation for all three growth factors appeared to be around the highest concentration tested which was  $10^{-7}$  Molar. The relative stimulation of fibroblast proliferation, migration and collagen production is summarised (**Figure 30**).

**Figure 27** Effects of growth factors EGF, bFGF, and TGF- $\beta$ 1 on ocular fibroblast migration (modified Boyden chambers)

Growth factors and ocular fibroblast migration (Modified Boyden chambers)



All 3 growth factors stimulated migration of human Tenon's capsule fibroblasts. TGF- $\beta$ 1 stimulated maximal fibroblast migration at much lower concentrations than bFGF or EGF. Error bars = SEM. \* = significantly different ( $p < 0.05$ ) from negative control of DMEM/BSA.

**Figure 28** Chequerboard analysis of human Tenon's capsule fibroblast migration to epidermal growth factor, basic fibroblast growth factor and transforming growth factor- $\beta$ 1.

EGF (Concentration in ng/ml)		Upper Chambers (No cells)				
		0	0.25	0.5	1.0	2.0
Lower Chambers (With Fibroblasts)	0	28 ± 4	46 ± 7	99 ± 8	121 ± 9	123 ± 14
	0.25	39 ± 10	47 ± 8	94 ± 6	103 ± 11	113 ± 6
	0.5	59 ± 8	62 ± 6	60 ± 8	83 ± 16	96 ± 5
	1.0	57 ± 10	45 ± 7	43 ± 6	69 ± 7	70 ± 14
	2.0	46 ± 9	47 ± 8	88 ± 10	84 ± 12	77 ± 9

bFGF (Concentration in ng/ml)		Upper Chambers (No cells)				
		0	20	40	80	160
Lower Chambers (With Fibroblasts)	0	12 ± 4	34 ± 3	49 ± 6	77 ± 5	105 ± 4
	20	13 ± 6	22 ± 8	54 ± 7	68 ± 1	80 ± 6
	40	14 ± 8	12 ± 9	37 ± 5	47 ± 6	65 ± 5
	80	28 ± 10	29 ± 8	28 ± 6	39 ± 7	57 ± 4
	160	52 ± 1	37 ± 8	41 ± 6	48 ± 1	62 ± 9

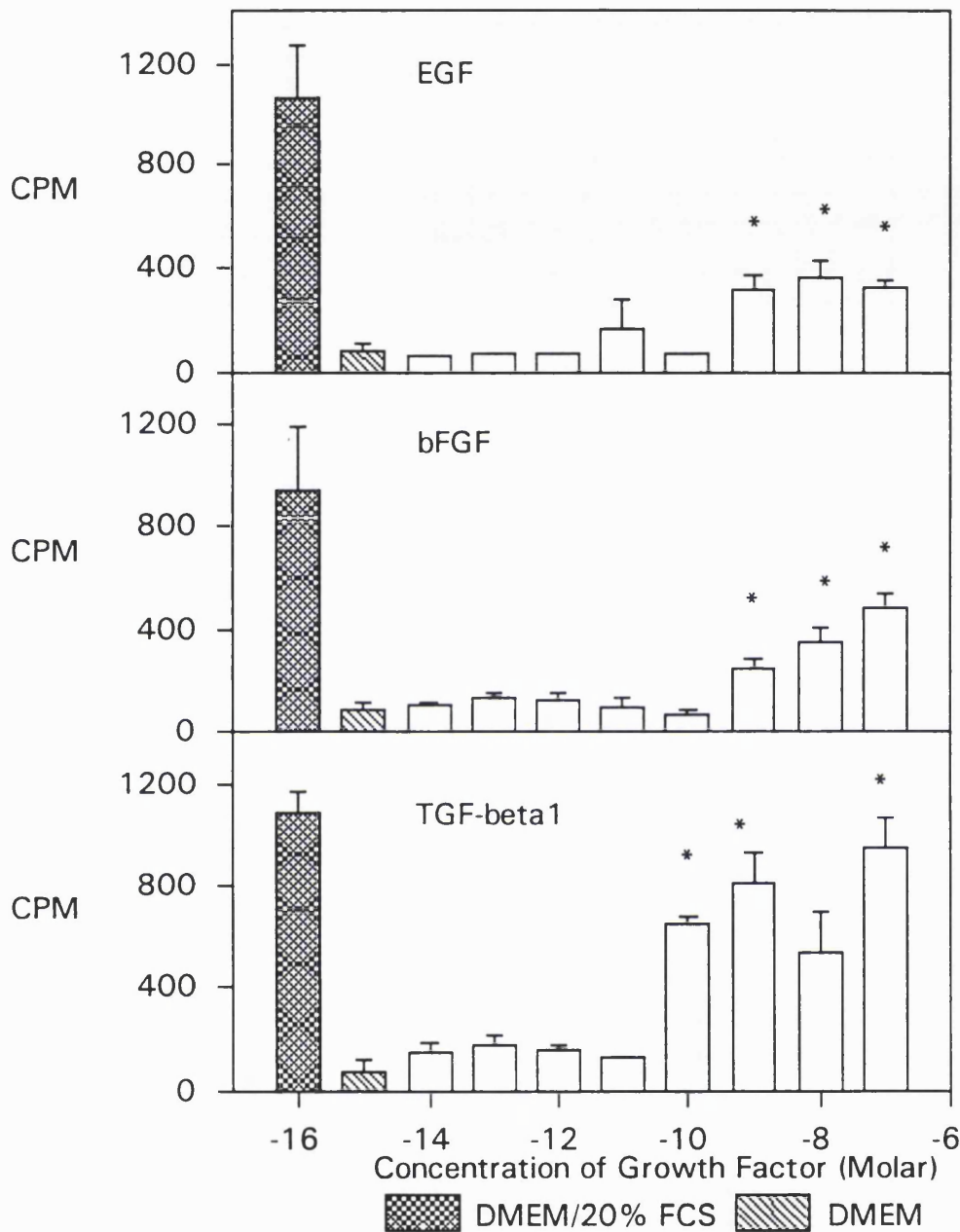
  

TGF- $\beta$ <sub>1</sub> (Concentration in pg/ml)		Upper Chambers (No cells)				
		0	0.25	0.5	1.0	2.0
Lower Chambers (With Fibroblasts)	0	24 ± 3	33 ± 2	43 ± 4	87 ± 6	78 ± 7
	0.25	33 ± 3	19 ± 4	22 ± 1	38 ± 7	53 ± 5
	0.5	17 ± 2	19 ± 3	15 ± 3	44 ± 5	48 ± 6
	1.0	18 ± 4	26 ± 3	22 ± 3	25 ± 3	39 ± 3
	2.0	20 ± 1	16 ± 4	17 ± 3	25 ± 2	22 ± 3

Chequerboard analysis revealed that all three growth factors resulted in the migration of Tenon's fibroblasts, and suggested that EGF and bFGF stimulated migration by stimulating both chemotaxis and chemokinesis (the number of cells migrated increased as the concentrations of the growth factor were increased in both upper and lower chambers). However, the chemokinetic effect was smaller than the chemotactic effect for both these growth factors. TGF- $\beta$ 1 appeared to stimulate migration primarily by stimulating chemotaxis rather than chemokinesis (no increase in the number of cells migrating as the concentration of TGF- $\beta$ 1 was increased in both the upper and lower chambers).

**Figure 29** Effects of growth factors EGF, bFGF, and TGF- $\beta$ 1 on ocular fibroblast collagen production ( $^3\text{H}$ -Proline uptake)

Growth factors and ocular fibroblast collagen production ( $^3\text{H}$  proline uptake)



All 3 growth factors stimulated some increase in  $^3\text{H}$ -proline uptake. However, TGF- $\beta$ 1 stimulated much larger increase in  $^3\text{H}$ -proline uptake than either EGF or bFGF. Higher concentrations of TGF- $\beta$ 1 were almost equivalent to the effect of 20% serum. Error bars = SEM. \* = significantly different (p < 0.05) from negative control of DMEM/BSA.

**Figure 30** Table summarising the stimulation of proliferation, migration and collagen production relative to positive control of 20% FCS/DMEM and negative control of DMEM only.

	Growth factor		
	EGF	bFGF	TGF- $\beta$ 1
<b>Proliferation (<math>^3\text{H}</math>-thymidine uptake)</b>			
Optimal concentration (Molar)	$10^{-9}$	$10^{-11}$	$10^{-12}$
DMEM media only	1.77	3.38	4.11
20% FCS/DMEM	0.66	1.06	1.19
<b>Migration (Modified Boyden chamber)</b>			
Optimal concentration (Molar)	$10^{-10}$	$10^{-8}$	$10^{-13}$
DMEM media only	8.52	4.66	6.30
20% FCS/DMEM	1.54	1.36	1.24
<b>Collagen production (<math>^3\text{H}</math>-proline uptake)</b>			
Optimal concentration (Molar)	$10^{-8}$	$10^{-7}$	$10^{-7}$
DMEM media only	4.32	6.47	12.72
20% FCS/DMEM	0.34	0.51	0.87

This table summarises the effects of the three growth factors on ocular fibroblast proliferation, migration and collagen production over a similar concentration range for all three growth factors. For this series of experiments, TGF- $\beta$ 1 stimulated much more collagen production and proliferation than the other two growth factors.

### **3.4 Effects of antiproliferative agents on ocular fibroblasts**

#### **3.41 1-14 day exposure to sodium butyrate and 5-fluorouracil**

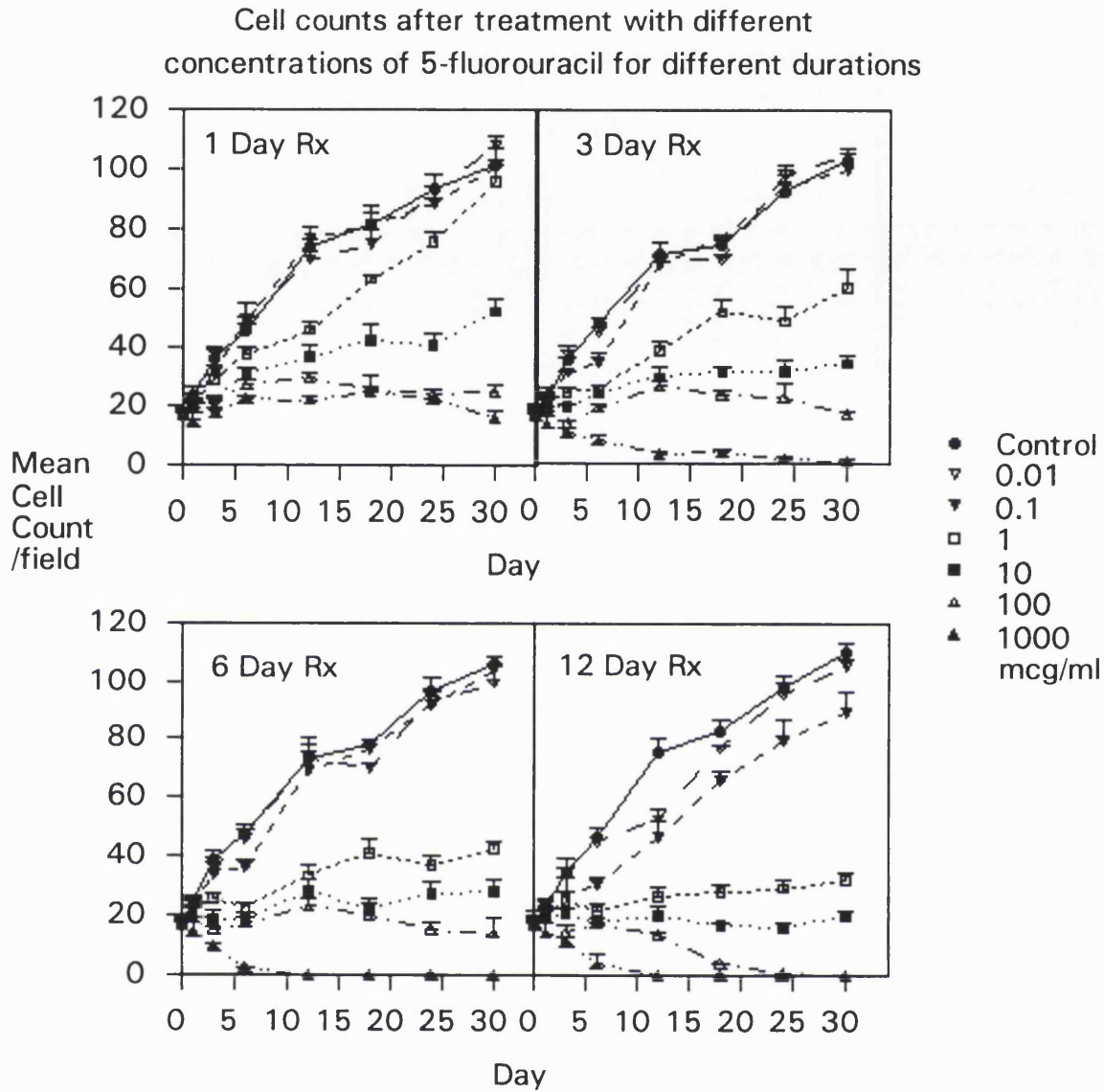
##### **3.41a Cell numbers**

Both 5-fluorouracil and sodium butyrate inhibited the increase in cell numbers which occurred when pre-confluent human Tenon's fibroblasts were stimulated with serum (**Figures 31 and 32**). This inhibition was statistically significant after one days treatment only with the highest concentration of 5-fluorouracil (1000  $\mu\text{g/ml}$ ), but the inhibition was statistically significant after three or more days of treatment with lower doses of 5-fluorouracil and with sodium butyrate. With an increasing period of treatment, the relative inhibition of cell division became more apparent as the control cells continued to increase. At a concentration of 1000  $\mu\text{g/ml}$  of 5-fluorouracil, an actual fall in cell number with gradual loss of the cell population was seen after removal of the drug, and refeeding with serum and media, even after only three days' treatment. At the 100  $\mu\text{g/ml}$  concentration of 5-fluorouracil, gradual cell loss occurred after 12 days of treatment even after cessation of treatment. With sodium butyrate, cell loss also occurred at the 11000  $\mu\text{g/ml}$  (100mM) concentration. Most of the cell loss with the sodium butyrate occurred during treatment, unlike the cell loss at the 100  $\mu\text{g/ml}$  concentration of 5-fluorouracil where a lot of the cell loss occurred after cessation of treatment. During treatment, at doses of 5-fluorouracil and sodium butyrate that caused growth arrest but not death, the cells assumed a spread out appearance with a much larger surface area, in contrast to their normal more spindle shaped appearance.

At 5-fluorouracil concentrations of 0.01, 0.1 and 1  $\mu\text{g/ml}$ , the cell numbers began to gradually increase after stopping treatment. However, the cells treated for 12 days with 1  $\mu\text{g/ml}$  did not show any increase in cell number, even 18 days after stopping treatment (day 30 of the experiment). At a concentration of 10  $\mu\text{g/ml}$ , treatment periods of 3 days or more resulted in no increase in cell number up to day 30. In contrast, with sodium butyrate treatment, the cell numbers began to increase after treatment was stopped at all dosing regimens except after treatment for 12 days with 11,000  $\mu\text{g/ml}$  (100mM) butyrate during which most of the cells died. Many of the cells treated with both 5-fluorouracil and butyrate at mid range doses showed an increase in cell size. However, although cell contact did occur at



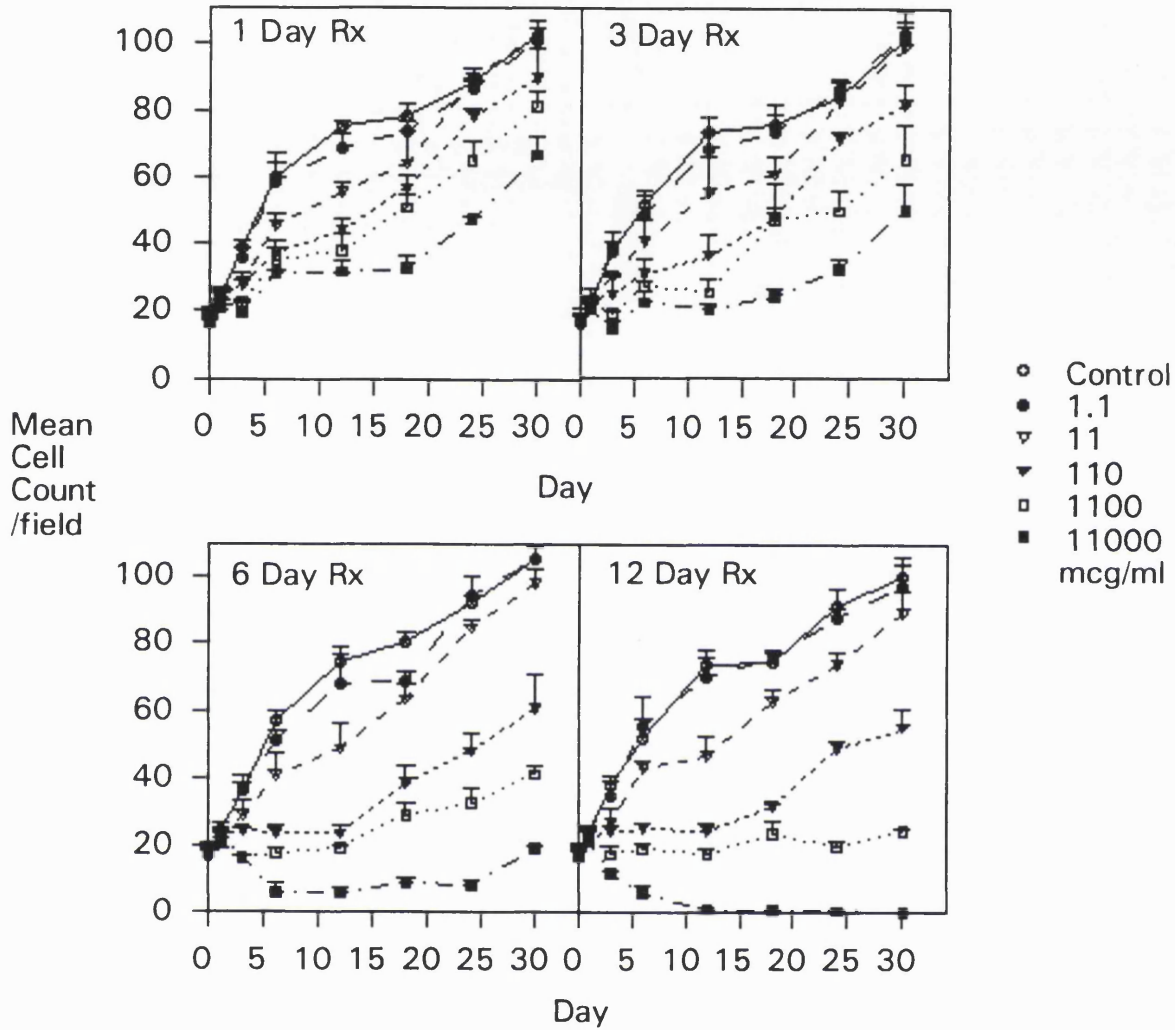
**Figure 31** Fibroblast cell counts for 30 days after treatment with different concentrations of 5-fluorouracil over different treatment periods.



Graph of cell counts over 30 days after treatment for 1, 3, 6, or 12 days continuous exposure. There is persistent growth arrest despite cessation of treatment. This even occurs after only one days treatment at the appropriate concentration. At the higher concentrations of 5-fluorouracil, there is cell death. Error bars = SEM.

**Figure 32** Fibroblast cell counts for 30 days after treatment with different concentrations of sodium butyrate over different treatment periods.

Cell Counts after treatment with different concentrations of butyrate for different durations



Graph showing cell counts over 30 days after treatments with 1, 3, 6, or 12 days respectively with sodium butyrate. There is reversibility once treatment is stopped, except for the very highest concentration of sodium butyrate with continuous treatment over 12 days which results in cell death. Error bars = SEM.

lower densities, there were many areas where the non-proliferating cells were not in contact where BrDU uptake was not occurring, suggesting that contact inhibition was not the reason for inhibition of proliferation.

The ID<sub>50</sub> doses are shown in tabular form (**Figure 33**). A 50% inhibition of the cell counts relative to the control was not reached until day 3 for the 5-fluorouracil and sodium butyrate treatment. However, after one days' treatment with 5-fluorouracil, the ID<sub>50</sub> level was reached from day 3 onwards and this reflected the gradual increase in the control cell counts with the continued inhibition of any increase in cell counts with the 5-fluorouracil treated cells. In comparison, the cells treated for 1 day with sodium butyrate only achieved a 50% inhibition at days 12 and 18 as the cells recovered and increased in number relative to the control cells. This trend was also seen in the ID<sub>50</sub> levels for 3, 6 and 12 days of treatment. There was only a small change in the ID<sub>50</sub> levels after treatment was stopped for 5-fluorouracil treatment, whereas the ID<sub>50</sub> levels rose when treatment was stopped with the sodium butyrate. The concentration of sodium butyrate required to inhibit the increase in cell numbers to the same degree as 5-fluorouracil during treatment was about 100 times greater on a weight for weight basis (1µg/ml 5-fluorouracil was about equivalent to 110µg/ml sodium butyrate).

#### **3.41b Proliferation (BrDU uptake)**

For the control cells, BrDU incorporation as a percentage of the total number of cells gradually fell as the cells become confluent (**Figures 34 and 35**). The fall in BrDU incorporation relative to the control cells was apparent by day 1 for both 5-fluorouracil and butyrate treated cells. For the cells treated with one day of 5-fluorouracil, the cells continued to take up BrDU when treatment was stopped and the uptake gradually decreased as the cells become more confluent. However, with longer treatment periods of 3, 6 and 12 days, the cells did not substantially increase their uptake of BrDU when treatment was stopped. For all treatments with 5-fluorouracil, the percentage of cells positive for BrDU after release from treatment never rose significantly above the level of BrDU uptake during treatment. In comparison, the sodium butyrate treated cells increased their uptake of BrDU to above the treatment levels when released from the butyrate media. This marked increase in uptake occurred within 2 days or less of stopping the sodium butyrate treatment and was sustained until the cells began to approach confluence. Examples of positive and negative cells are shown in **Figures 36 and 37**.

**Figure 33** ID<sub>50</sub> concentrations for cells treated with different concentrations of 5-fluorouracil and Na butyrate for different durations

---

**ID<sub>50</sub> concentrations for 5-fluorouracil treated cells (μg/ml)**

Day	1 day Rx	3 day Rx	6 day Rx	12 day Rx
0	Not reached	Not reached	Not reached	Not reached
1	Not reached	Not reached	Not reached	Not reached
3	420	20.4	8.5	32.1
6	822	7.6	0.8	0.7
12	8.5	2.2	0.8	0.3
18	12.3	5.1	1.3	0.5
24	6.7	1.5	0.6	0.4
30	11.3	2.2	0.7	0.4

---

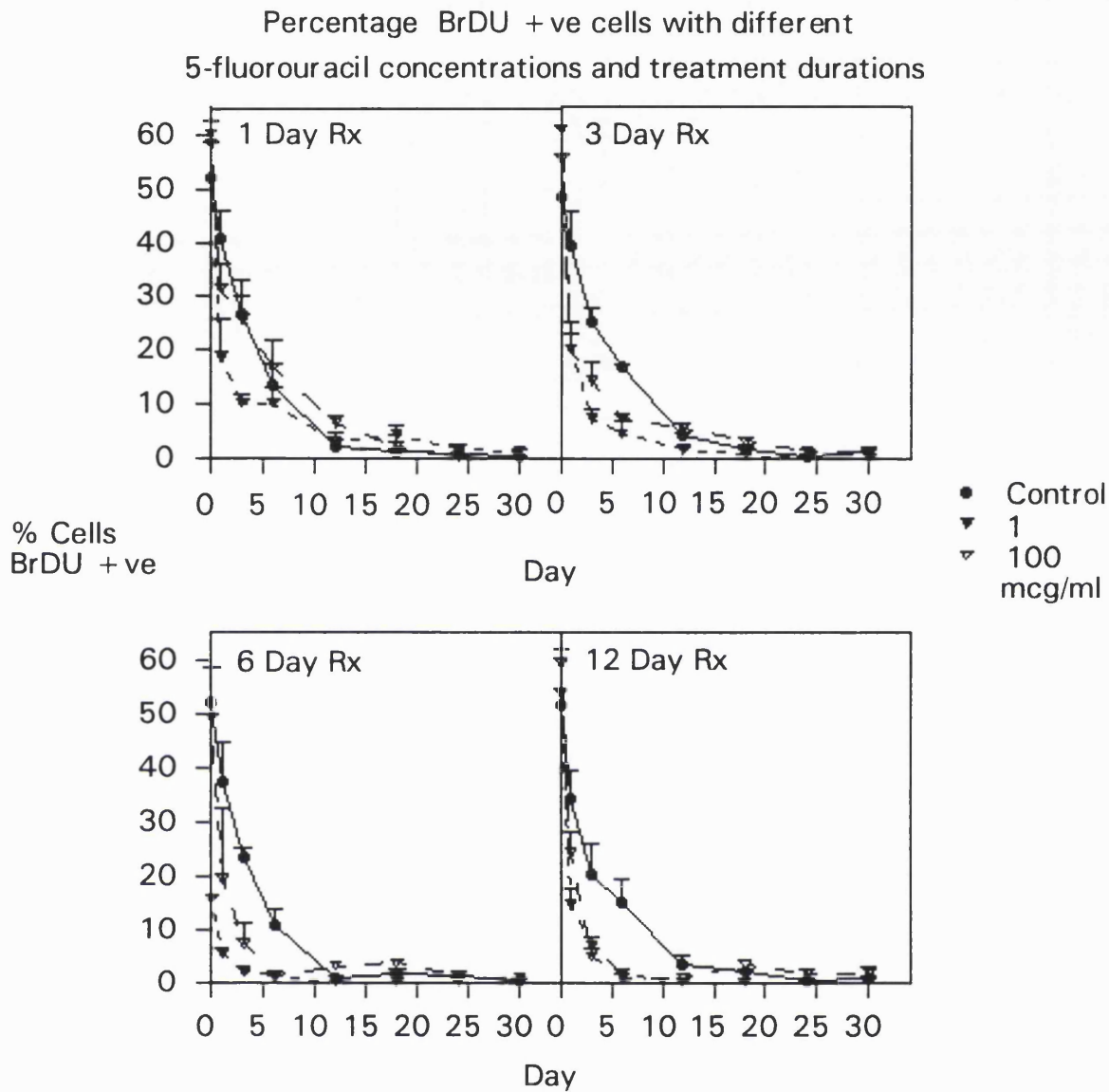
**ID<sub>50</sub> concentrations for sodium butyrate treated cells (μg/ml)**

Day	1 day Rx	3 day Rx	6 day Rx	12 day Rx
0	Not reached	Not reached	Not reached	Not reached
1	Not reached	Not reached	Not reached	Not reached
3	Not reached	1489 (13.5mM)	679 (6.2mM)	678 (6.1mM)
6	Not reached	2038 (18.5mM)	57.6 (0.5mM)	100.1 (0.9mM)
12	1222 (11.1mM)	105.2 (0.96mM)	30 (0.3mM)	29.7 (0.3mM)
18	4816 (43.7mM)	2778 (25.2mM)	92.7 (0.8mM)	73.1 (0.7mM)
24	Not reached	3063 (27.8mM)	140 (1.2mM)	139.9 (1.3mM)
30	Not reached	10845 (98.5mM)	267 (2.4mM)	156.8 (1.4mM)

---

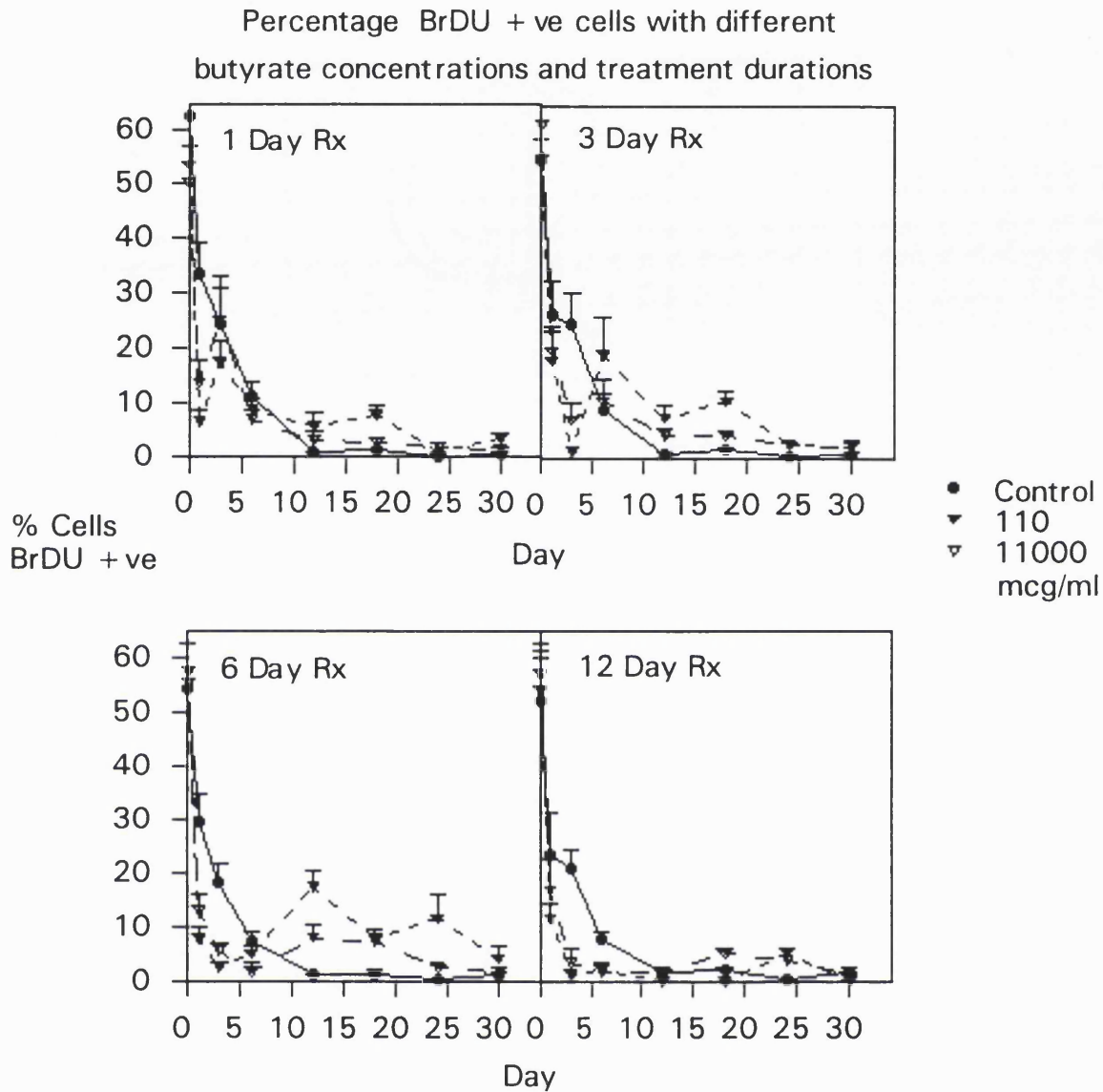
These tables show the concentrations required to achieve a 50% inhibition of proliferation compared to the control cells. If a less than 50% inhibition is achieved then the ID<sub>50</sub> concentration is defined as not reached.

**Figure 34** Graph of percentage of BrDU positive fibroblasts over 30 days after treatment with different concentrations of 5-fluorouracil for different treatment periods.



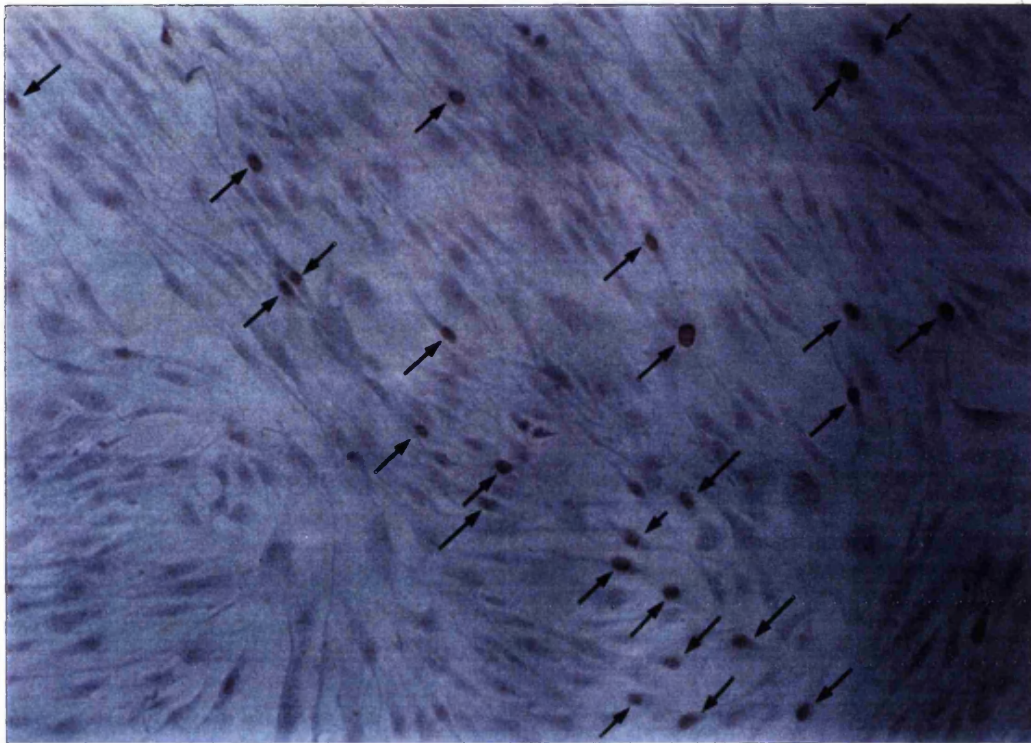
Graph showing percentage of BrDU positive cells after treatment with 5-fluorouracil at two concentrations for different durations. The percentage of BrDU positive cells falls as the cells reach confluence. After treatment with the two concentrations of 5-fluorouracil, the percentage of BrDU positive cells falls more rapidly with the higher concentration and does not rise even after treatment with 5-fluorouracil is stopped. Error bars = SEM.

**Figure 35** Graph of percentage of BrDU positive fibroblasts over 30 days after treatment with different concentrations of sodium butyrate for different treatment periods.

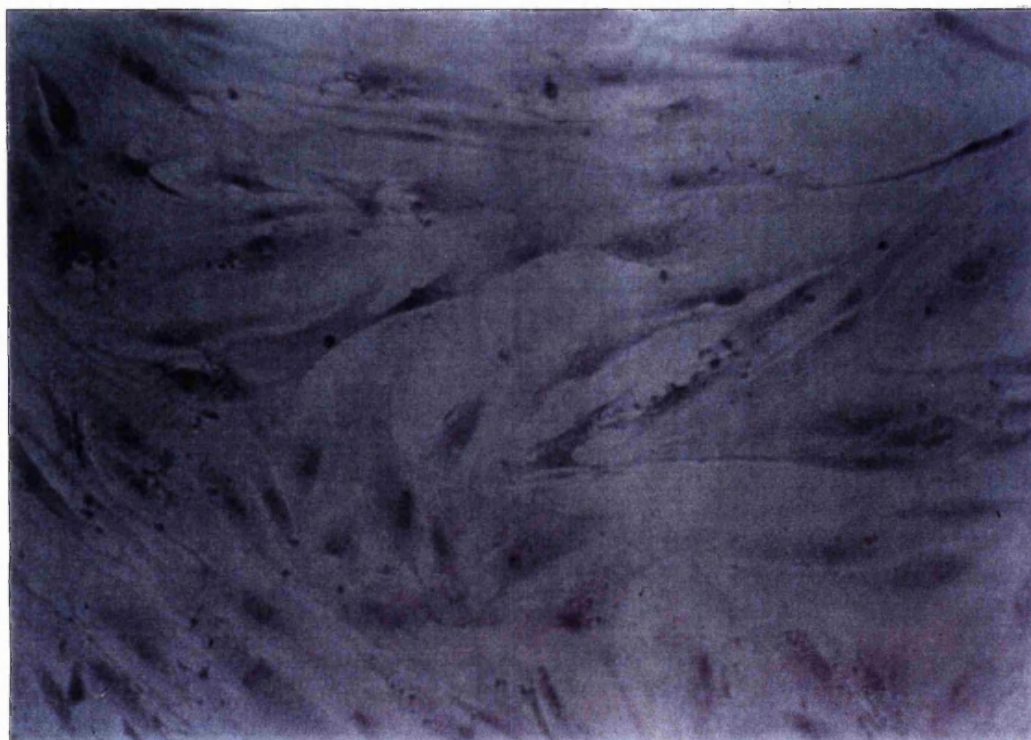


Graph showing percentage of BrDU positive cells after treatment with sodium butyrate for different durations. In contrast to 5-fluorouracil after butyrate treatment is stopped the number of BrDU positive cells increases, and then falls as the cells reach confluent. Error bars = SEM.

**Figure: 36** Human Tenon's capsule fibroblasts with and without drug treatment after incubating with 1:1000 bromodeoxyuridine (BrDU) for 4 hours and subsequent immunostaining for intracellular BrDU. Cells counterstained with haematoxylin.



**Day 6 Control cells** after 6 days in culture. Many cell nuclei are positive (red colour) for BrDU suggesting active uptake of DNA precursors in proliferating cells. The cells are small and spindle shaped. Magnification X 400.



**Day 6** Cells treated for 6 days with 5-fluorouracil 1  $\mu\text{g/ml}$ . The cells are large and some are multinucleated. None of the cell nuclei are positive for BrDU. The cells treated with concentrations of 110  $\mu\text{g/ml}$  and above of sodium butyrate showed a similar absence of BrDU positive nuclei. Magnification X 400.

**Figure: 37** Human Tenon's capsule fibroblasts treated for 3 days with either sodium butyrate or 5-fluorouracil. Cells washed of drug and stimulated with serum without drug until day 24, then incubated with 1:1000 bromodeoxyuridine (BrDU) for 4 hours and subsequently immunostained for intracellular BrDU. Cells counterstained with haematoxylin.



**Day 24** Cells treated with **sodium butyrate 11,000  $\mu\text{g}/\text{ml}$  for 3 days**. Several cell nuclei are positive (red colour) for BrDU suggesting active uptake of DNA precursors in proliferating cells. The cells are still much larger than control cells. Magnification X 400.



**Day 24** Cells treated with **5-fluorouracil 100  $\mu\text{g}/\text{ml}$  for 3 days**. The cells are still large and some are multinucleated. None of the cell nuclei are positive for BrDU. Magnification X 400.



### **3.41c Cell viability (Trypan Blue)**

At doses of  $1\mu\text{g/ml}$  5-fluorouracil and  $110\mu\text{g/ml}$  (1 mM) sodium butyrate, the percentage of trypan blue positive cells remained relatively constant, but rose slightly as the period of treatment increased (**Figures 38 and 39**). At doses of  $100\mu\text{g/ml}$  of 5-fluorouracil and  $11000\mu\text{g/ml}$  (100 mM) of sodium butyrate, there was a conspicuous increase in the number of cells that were trypan blue positive during the period of treatment. This was apparent after about 3 days of treatment with both 5-fluorouracil and sodium butyrate. With sodium butyrate treatment, the percentage of trypan blue positive cells rose and then gradually fell, compared to the 5-fluorouracil treated cells where the percentage of trypan blue positive cells continued to increase even after treatment had been stopped.

## **3.42 Beta irradiation (Single application)**

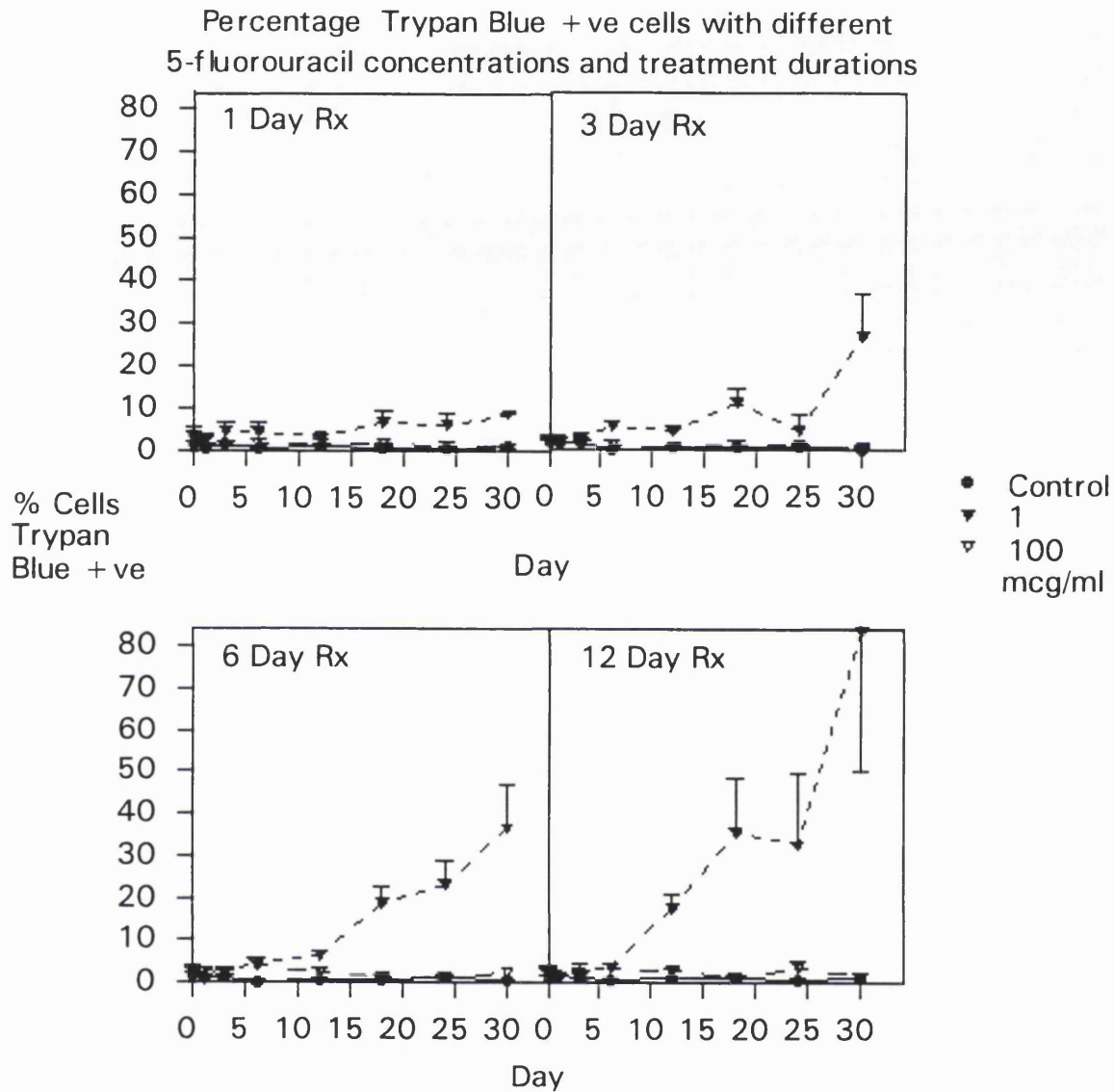
### **3.42a Cell number**

There were no statistically significant differences between the groups before treatment. However, three days after treatment, the control cells had increased in number significantly more compared with the treated cells, and this trend continued for day 7 and 14. At the highest doses of 1500 and 3000 CGy, there was a fall in the total number of cells when compared to the starting number of cells (**Figure 40**). At day 3, the untreated control cells had increased significantly more than the treated cells, but within the treatment groups only the 1500 and 3000 rad treated cells were different from the 100 CGy group. For days 7 and 14 the spread within the groups increased, and at day 14 the groups could be divided into those treated with 100, 250 and 500 CGy, those receiving 750 and 1000 CGy and those treated with 1500 and 3000 CGy, which were statistically distinct from each other. Cell number decreased relative to the control when cells were treated with increasing radiation doses, and this effect was more pronounced at day 7 and 14 compared to day 3.

Using regression analysis a decrease in proliferation with increasing radiation dose was significant at the level of  $p < 0.0001$  for all three days. The change in cell number for each dose of radiation at days 3, 7 and 14 was only significant at doses of 750 CGy or more ( $p < 0.05$  analysis of variance). The doses which inhibited proliferation more than 50% ( $\text{ID}_{50}$  level) and yet did not cause a fall in the overall number of cells

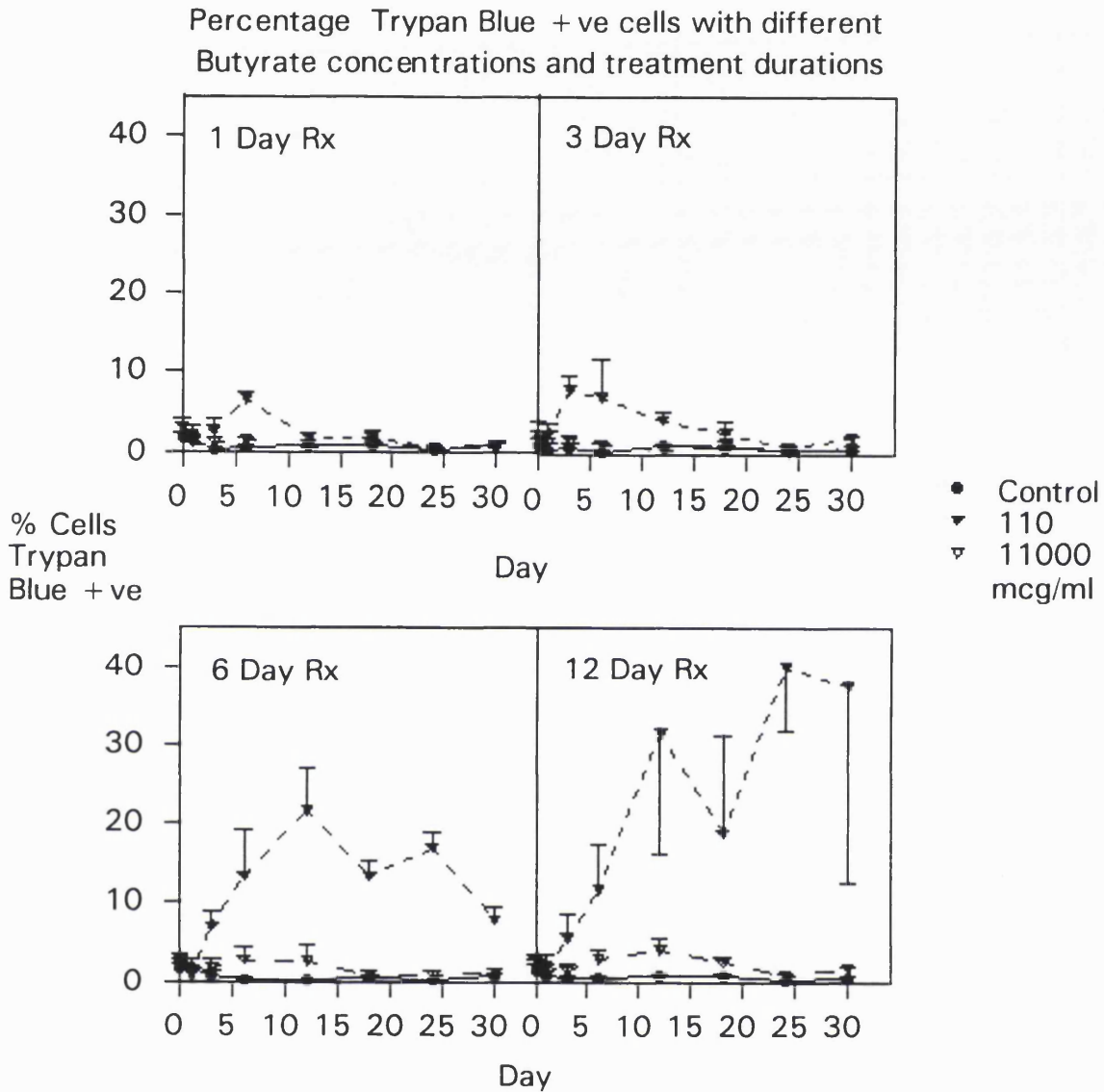
Figure 38

Graph of percentage of trypan blue positive fibroblasts over 30 days after treatment with different concentrations of 5-fluorouracil over different treatment periods.



At the highest concentration of 5-fluorouracil treatment, the percentage of trypan blue positive cells increases even after treatment has stopped, indicating progressive cell death. The error bars (standard area of the mean) are very large because with the 12 day treatment many cells had died, and there was a great variation in the number of cells per field. With the lower concentration of 5-fluorouracil there was no significant increase in the number of trypan blue positive cells, despite the fact the cells were growth arrested. Error bars = SEM.

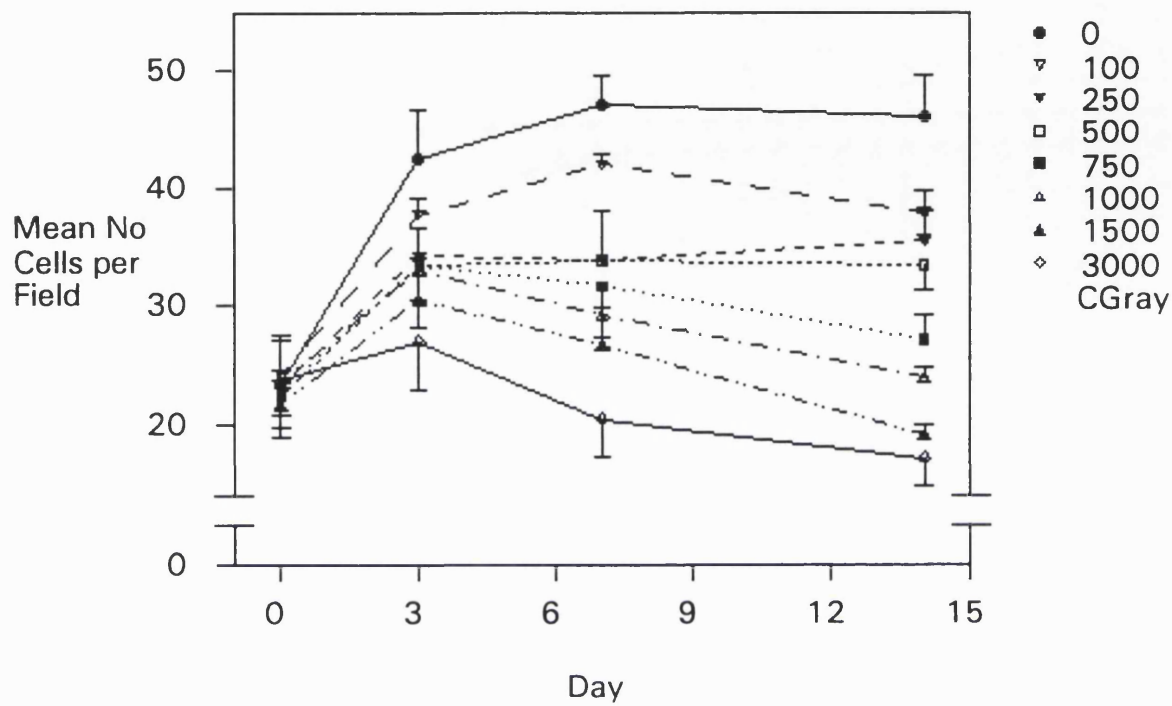
**Figure 39** Graph of percentage of trypan blue positive fibroblasts over 30 days after treatment with different concentrations of sodium butyrate over different treatment periods.



At the highest concentration of butyrate there was a rise in the number of trypan blue positive cells, but this fell when butyrate treatment was stopped. However, for the longest period of treatment (12 days) at the highest concentration there was still a rise in the number of trypan blue positive cells. The error bars (standard area of the mean) are very large, again because a large number of cells were dying, and there was a considerable variation from field to field. Error bars = SEM

**Figure 40** Graph of fibroblast cell counts over 14 days after treatment with different doses of  $\beta$ -radiation, and the  $ID_{50}$  doses at 3, 7 and 14 days respectively.

Cell Counts after different doses of beta-radiation



$ID_{50}$  radiation doses for proliferating human Tenon's capsule fibroblasts

Day	Radiation Dose (CGy)
3	Not reached
7	2135.7
14	1083.3

A single dose of  $\beta$ -radiation causes long-term inhibition of proliferation up to 14 days. At the highest dose there is actually a fall in cell numbers. Error bars = SEM.

were 500, 750 and 100 CGy. For the groups treated with 3000 CGy at day 7, and those treated with 1500 and 3000 CGy at day 14 there was a fall in the cell numbers below the number in the wells originally. Morphologically, the untreated fibroblasts maintained a relatively spindle shaped appearance. At increasing doses of radiation the cells became more polymorphic. At doses between 500 to 1000 CGy there was more of a variation in cell size with some large irregularly shaped cells. At doses of 1500 and 3000 CGy the cells were mostly small and irregular, with noticeably more cells floating free in the media.

### **3.42b Proliferation (Thymidine Uptake)**

Initially, when the cells were preconfluent immediately pretreatment, there was active uptake of thymidine in all groups (**Figure 41**). In the control group, thymidine incorporation then fell as the cells became confluent and had reached a plateau by day 7. At day 3, cells treated with 250, 750 and 3000 CGy all had reduced thymidine uptake relative to the untreated control cells. At day 7, there was no statistically significant difference between the cells treated with 250 CGy and the control, but the cells treated with 750 and 3000 CGy had a significantly lower thymidine uptake. At day 14, the thymidine uptake of the control cells had plateaued, but the thymidine uptake of the cells treated with 750 and 3000 CGy was still significantly reduced.

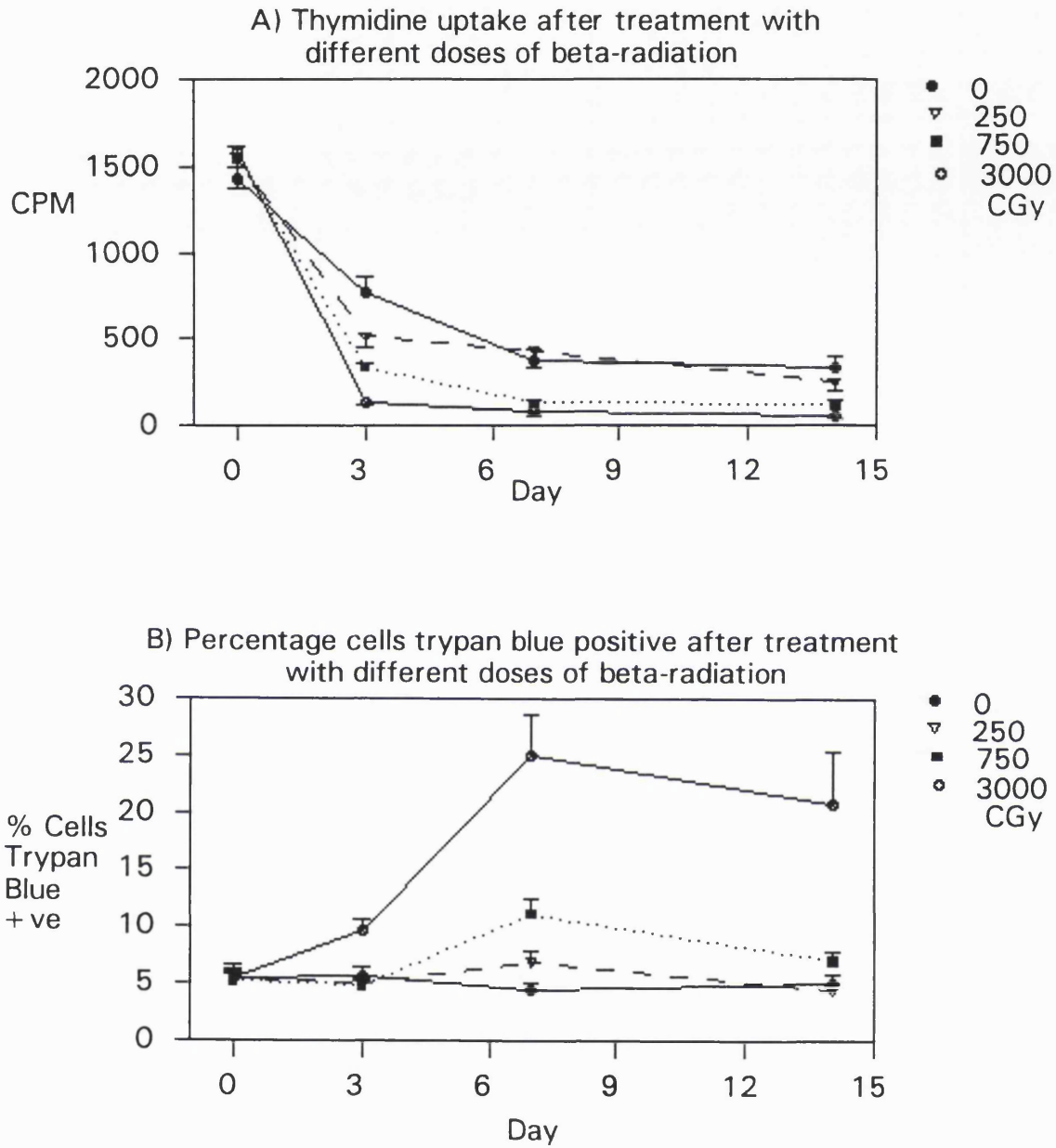
### **3.42c Cell viability (Trypan blue)**

The percentage of trypan blue positive cells was relatively consistent in the control cells throughout the experiment (**Figure 41**). There was a no significant increase in the number of positive cells in the cells treated with 250 CGy at day 7. The number of trypan blue positive cells was significantly increased compared to the control cells at day 7 and 14 in the cells treated with 750 CGy, and at days 3, 7 and 14 in the cells treated with 3000 CGy.

### **3.43 5 minute exposures to 5-fluorouracil, 5-fluorouridine and mitomycin-c**

Five minutes of exposure to high doses 5-fluorouracil, 5-fluorouridine and mitomycin-c all resulted in significant inhibition of fibroblast proliferation relative to the untreated, serum stimulated control cells up to 36 days. Exposure to 5-fluorouracil at

**Figure 41** Graphs of a)  $^3\text{H}$ -thymidine uptake and b) percentage trypan blue positive fibroblasts after treatment with different doses of  $\beta$ -radiation.



Thymidine uptake falls as the cells become confluent in culture. After treatment with  $\beta$ -radiation the thymidine uptake falls more rapidly, and stays down at the dosages treated. There is a marked rise in the number of trypan blue positive cells with the higher doses of radiation, indicating some degree of cell death at higher doses. Error bars = SEM

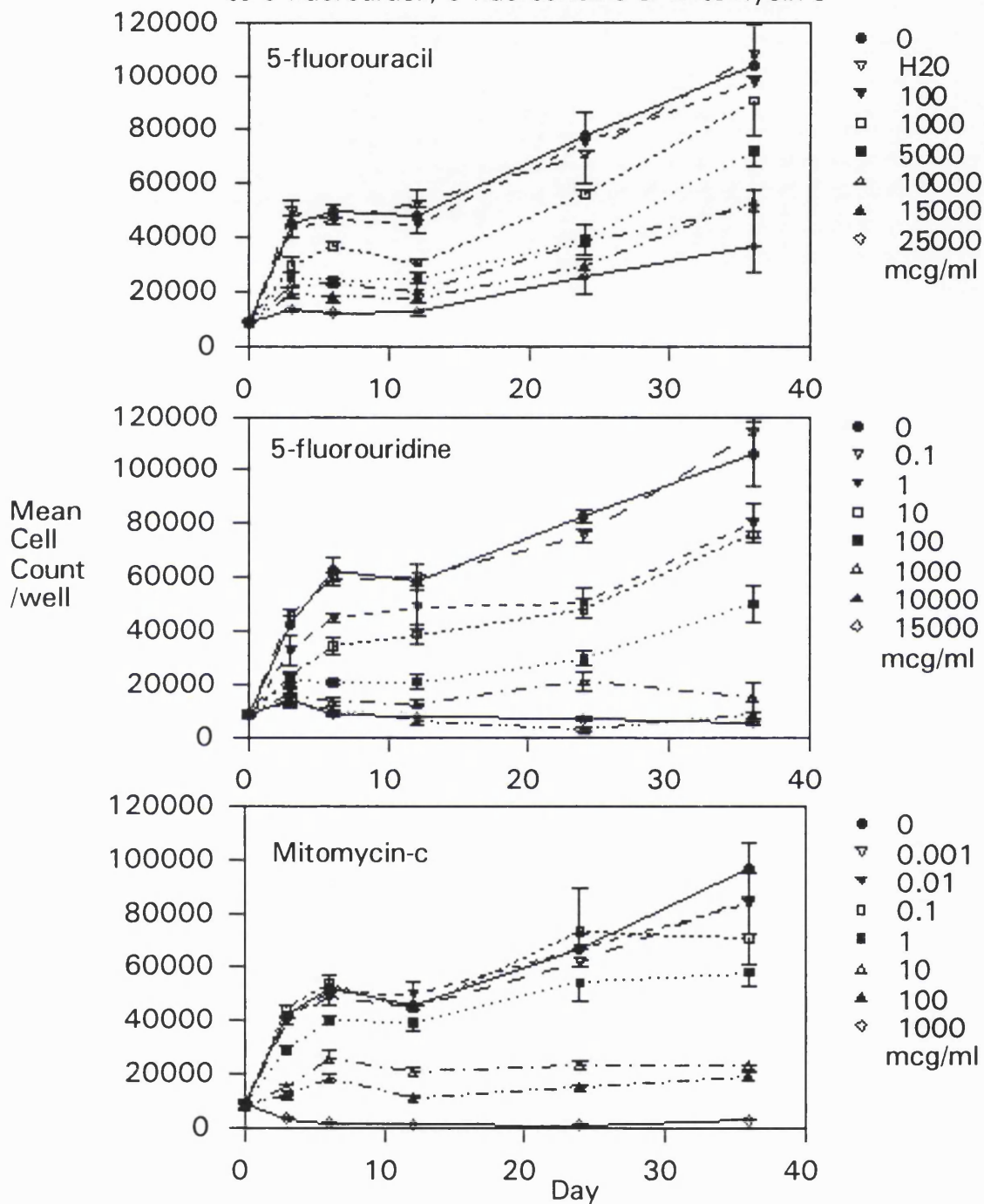
doses ranging from 25000  $\mu\text{g/ml}$  down to 5000  $\mu\text{g/ml}$  reduced cell numbers significantly relative to the serum stimulated untreated cells for the entire 36 day period (Figure 42). Exposure to 5-fluorouridine at concentrations from 15000 $\mu\text{g/ml}$  to 10  $\mu\text{g/ml}$ , and mitomycin-c at concentrations of 1000  $\mu\text{g/ml}$  to 10  $\mu\text{g/ml}$  (Figure 42) also resulted in a significant reduction in cell numbers relative to the untreated control cells.

The highest concentration of 5-fluorouracil did not result in an overall fall in the number of cells relative to the number of cells at the start of the experiment. However, 5-fluorouridine at a concentration of 15000  $\mu\text{g/ml}$  and mitomycin-c at a concentration of 1000  $\mu\text{g/ml}$  caused a significant decrease in the number of cells compared to the number of cells at the start of the experiment. This fall in cell number occurred rapidly after treatment with the highest dose of mitomycin-c, resulting a 60% reduction by day three, whereas with the highest doses of 5-fluorouridine the cell numbers fell more gradually to approximately 65% of the initial cell number at day 36. At doses of 25000  $\mu\text{g/ml}$  to 1000  $\mu\text{g/ml}$  for 5-fluorouracil, 1000  $\mu\text{g/ml}$  to 1  $\mu\text{g/ml}$  for 5-fluorouridine and 100  $\mu\text{g/ml}$  to 10  $\mu\text{g/ml}$  for mitomycin-c there was an increase in cell numbers from approximately 2 to 10 fold over the 36 day period. However, the cell numbers never equalled those of the untreated serum stimulated control cells. Concentrations of 100  $\mu\text{g/ml}$  of 5-fluorouracil, 0.1  $\mu\text{g/ml}$  of 5-fluorouridine and 0.001 to 0.1  $\mu\text{g/ml}$  of mitomycin-c did not cause significant changes in cell number relative to the untreated serum stimulated control cells. The inhibition of proliferation relative to the control for each concentration remained fairly consistent up to 36 days. This is reflected in the levels of drug required to inhibit proliferation by 50% relative to the control ( $\text{ID}_{50}$ ) (Figure 43). Apart from the day 3 level for 5-fluorouracil and 5-fluorouridine, the  $\text{ID}_{50}$  levels for all three drugs were within one logarithmic unit for the 36 day period.

At a concentration of 100  $\mu\text{g/ml}$  of mitomycin-c, the number of cells did not increase more than 2.5 times relative to the density at day 0 of the experiment over a 36 day period, despite stimulation throughout this period with 10% FBS. At a concentration of 1000  $\mu\text{g/ml}$  of mitomycin-c, more than 65% of the cells died. Concentrations of 1000  $\mu\text{g/ml}$  or greater of 5-fluorouridine were required to restrict an increase in cell number to less than 2.5 times the starting number. Concentrations of 10,000  $\mu\text{g/ml}$  or more of 5-fluorouracil restricted the increase in cell number to less than 2.5 times the starting number, but only for the first 12 days. After this, the cell numbers rose more than 2.5 times above the starting figure for all concentrations

**Figure 42** Graph of fibroblast counts over 36 days after treatment with different concentrations of 5-fluorouracil, 5-fluorouridine and mitomycin-C for 5 minutes.

Mean Cell Counts over 36 days after 5 minute exposures to 5-fluorouracil, 5-fluorouridine or mitomycin-c



Graphs show that 5 minute treatments with all three agents had long-term effects on fibroblast proliferation. At the highest concentration of 5-fluorouracil there was recovery after 36 days, but still significant inhibition relative to control cells. Long-term growth arrest was achieved with 5-fluorouridine and mitomycin-c, and cell death occurred at the highest concentration. Error bars = SEM.



**Figure 43** Table of ID<sub>50</sub> concentrations at different time points over 36 days after 5 minute treatments with 5-fluorouracil, 5-fluorouridine and mitomycin-c for 5 minutes.

---

Day	DRUG CONCENTRATION		
	5-Fluorouracil	5-Fluorouridine	Mitomycin-c
3	10467.9	114.5	3.9
6	4526.4	15.9	8.9
12	5809.5	35.5	7.9
24	6216.9	23.8	4.7
36	9671.7*	77.4	1.9

\* Based on figures calculated from the 5000 and 10000  $\mu\text{g/ml}$  cell number levels, as 15000 and 10000  $\mu\text{g/ml}$  cell numbers cross over.

---

This table shows the ID<sub>50</sub> concentration at different time points after a 5 minute exposure to the various drugs. All drugs inhibited cell proliferation more than 50% compared to the untreated control up to 36 days. Sodium butyrate was not tested in this long term series as it did not significantly inhibit fibroblast proliferation after 5 minute treatments even at the maximal concentration possible.

tested. Morphological changes in the cells were apparent at high doses of all three drugs by Day 3, and were detectable one day after mitomycin-c. On day 3, the cells treated with 1000  $\mu\text{g/ml}$  of mitomycin-c were very rounded and there were many detached cells in the medium. The cells treated with the highest doses of 5-fluorouracil and 5-fluorouridine were pleomorphic with cells floating in the medium. After 12 days many of the cells treated with the highest doses of 5-fluorouridine and mitomycin-c had detached, and the remaining cells were small and rounded (**Figure 44**). Occasional areas were seen where the high densities of cells occurred due to cell clumping. The cells in these areas of high density appeared less affected morphologically. At intermediate doses of 5-fluorouracil, 5-fluorouridine and mitomycin-c the cells were non-confluent. At day 36, there were very few remaining cells at the highest doses of 5-fluorouridine and mitomycin-c, and at a dose of 25000  $\mu\text{g/ml}$  of 5-fluorouracil the cells were confluent in places but with many large abnormal cells (**Figure 45**). At intermediate doses of 5-fluorouracil, 5-fluorouridine and mitomycin-c the cells were confluent in places but were very abnormal and pleomorphic.

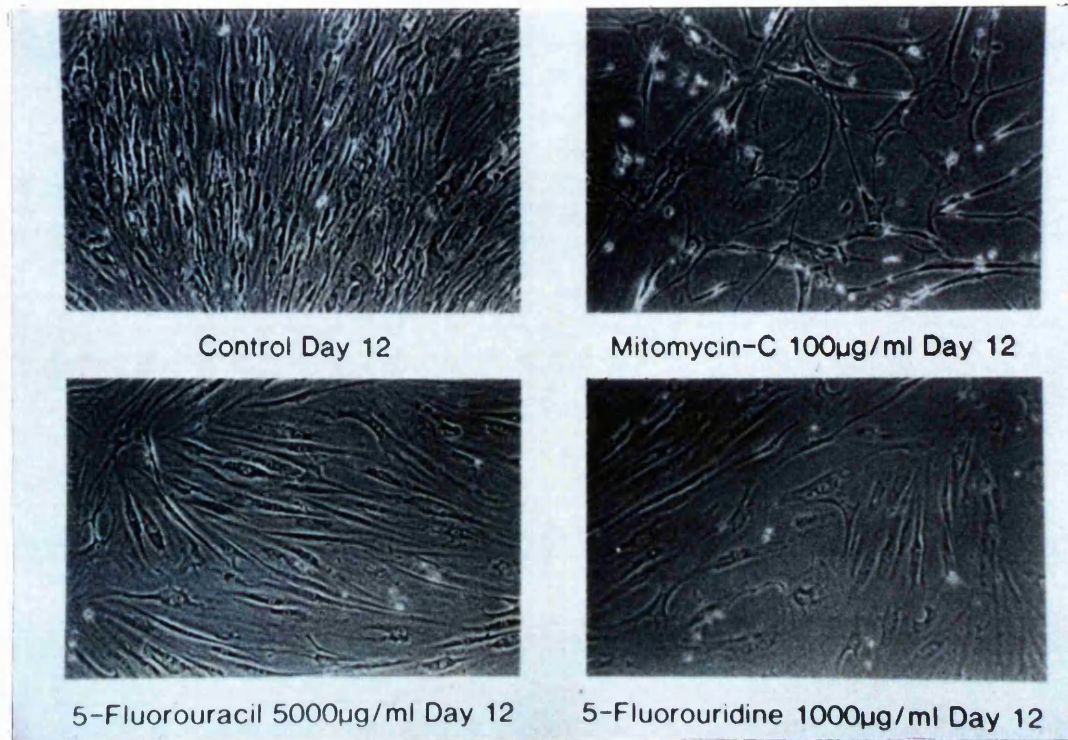
### **3.5 Pharmacokinetics of $^3\text{H}$ sodium butyrate subconjunctival injection**

Following a subconjunctival injection of 4.44 mg of sodium butyrate with radiolabelled sodium butyrate in 0.2 ml, the levels of radioactivity rapidly fell in the aqueous, cornea, conjunctiva and sclera (**Figure 46**). I assumed an inhibitory concentration (2mM sodium butyrate) based on our concurrent laboratory experiments and the scientific literature, and that the majority of the radioactivity represented biologically active butyrate. Based on these assumptions, by the first sampling at 30 mins, the concentration of butyrate in aqueous and cornea was below therapeutic levels by 30 minutes. In conjunctiva, therapeutic concentrations at the site of injection were maintained for about three hours, but in the conjunctiva 180° away for just over 30 minutes. In sclera, a therapeutic concentration was achieved for just under 2.5 hours at the site of injection, and for only 30 minutes in the sclera 180° away (**Figure 47**). The numeric results are summarized in **Figure 48**.

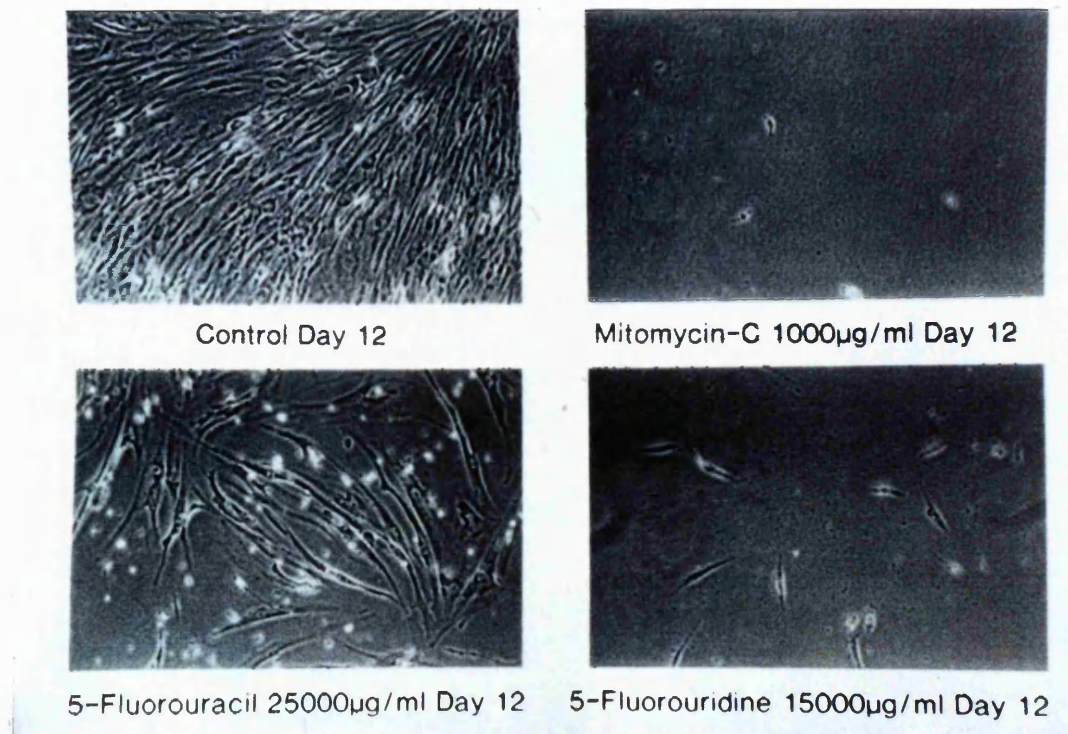
### **3.6 Effects of antiproliferative agents on experimental filtering surgery**

During experimental filtration surgery the conjunctiva was opened and a new channel (sclerostomy) was made with the punch. A peripheral section of the tissue

**Figure: 44 Human Tenon's capsule fibroblasts 12 days after after 5 minute treatments with 5-fluorouracil, 5-fluorouridine and mitomycin-c**

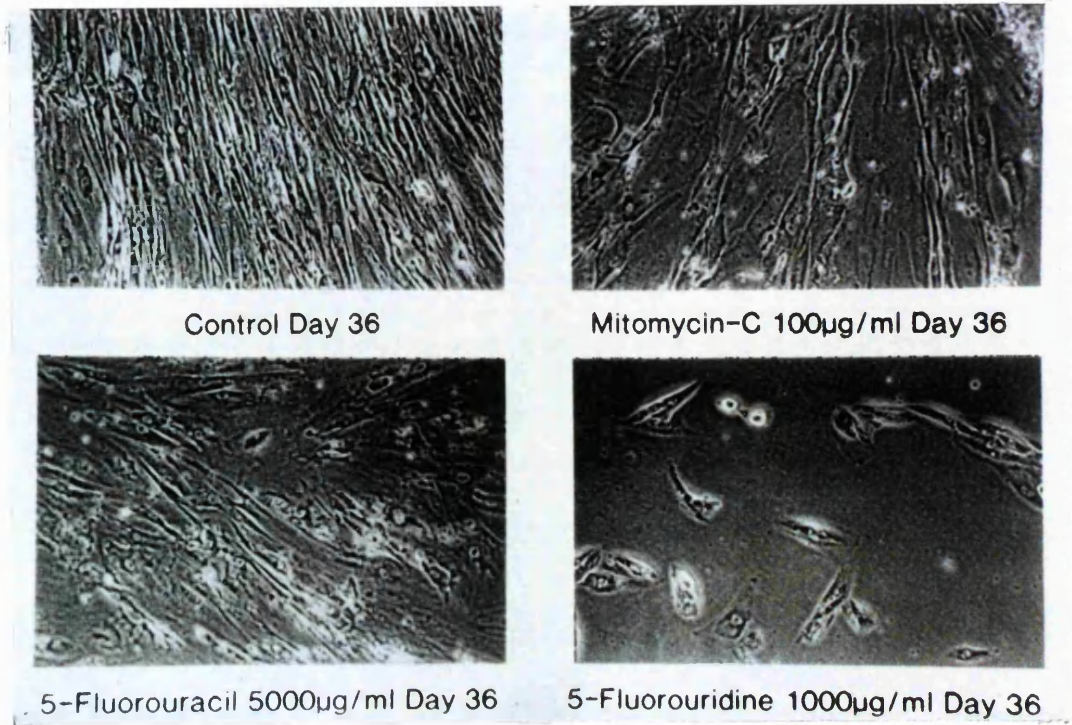


**Day 12** after treatment with intermediate concentrations of the three drugs. The cell numbers in the drug treated wells were significantly reduced compared with the control cells treated with distilled water. There were also more rounded and free floating cells in the treated wells.

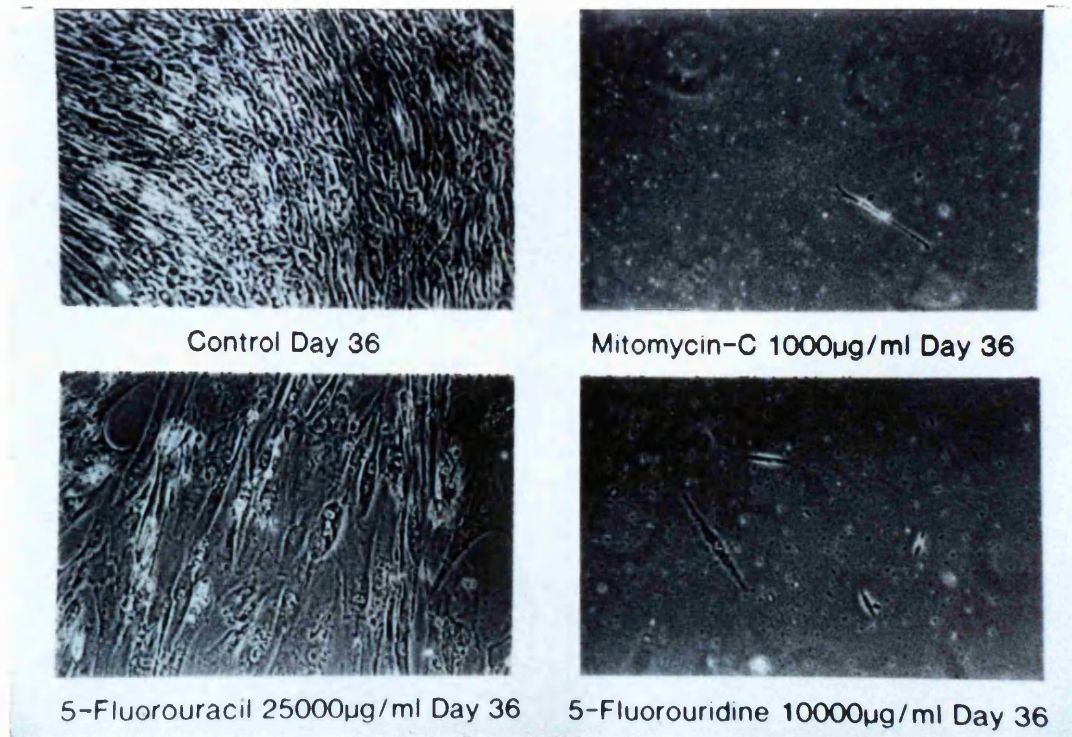


**Day 12** after treatment with high concentrations of the three drugs. The cell numbers in the drug treated wells were significantly reduced compared with the distilled water treated control cells. There was some cell death with all three drugs, but this was particularly marked in the mitomycin and 5-fluorouridine treated cells, and the remaining attached cells were abnormal and shrunken.

**Figure: 45 Human Tenon's capsule fibroblasts 36 days after after 5 minute treatments with 5-fluorouracil, 5-fluorouridine and mitomycin**

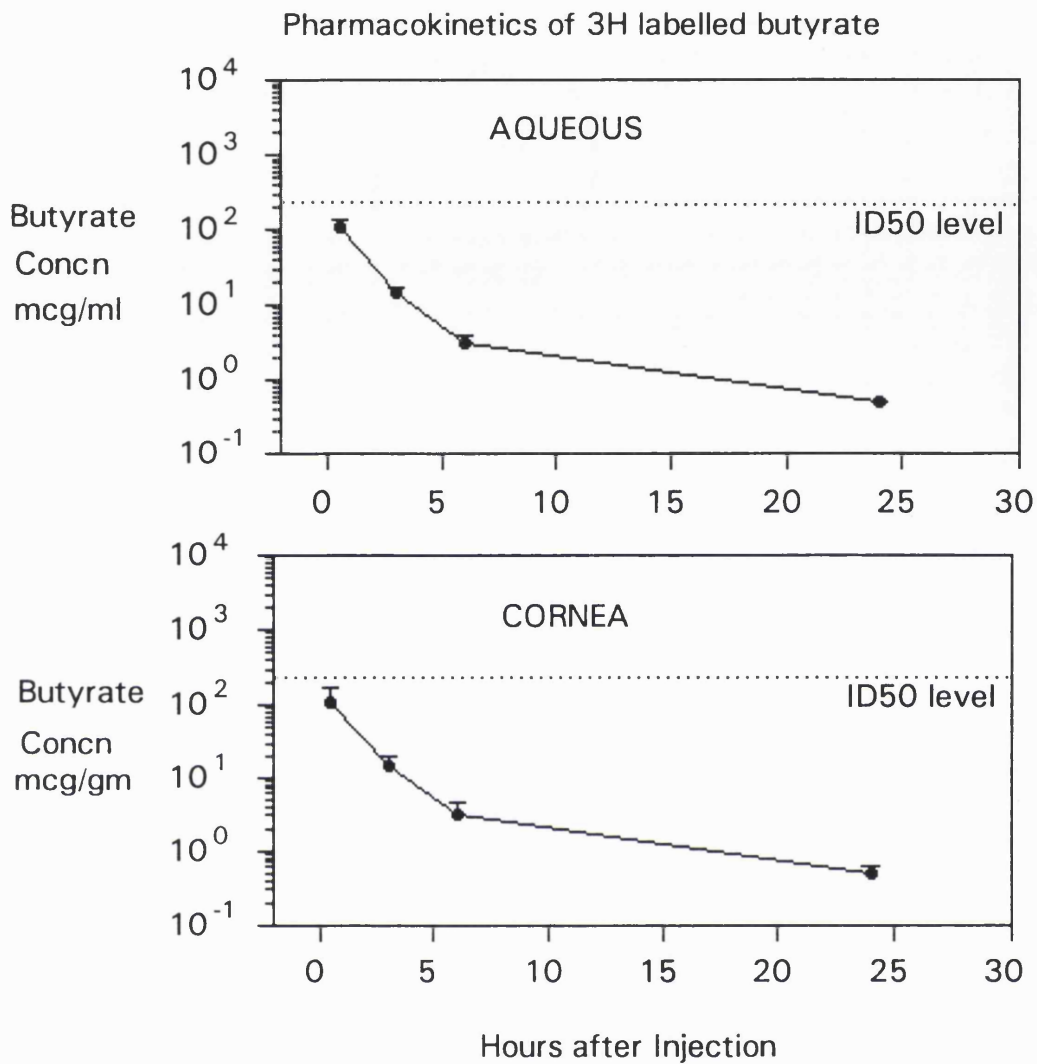


**Day 36** after treatment with intermediate concentrations of the three drugs. The cell numbers in the drug treated wells were significantly reduced compared with the control cells. The 5-Fluorouracil and mitomycin-c treated cells were also abnormally large and multinucleated. The 5-fluorouridine cells were markedly abnormal and shrunken.



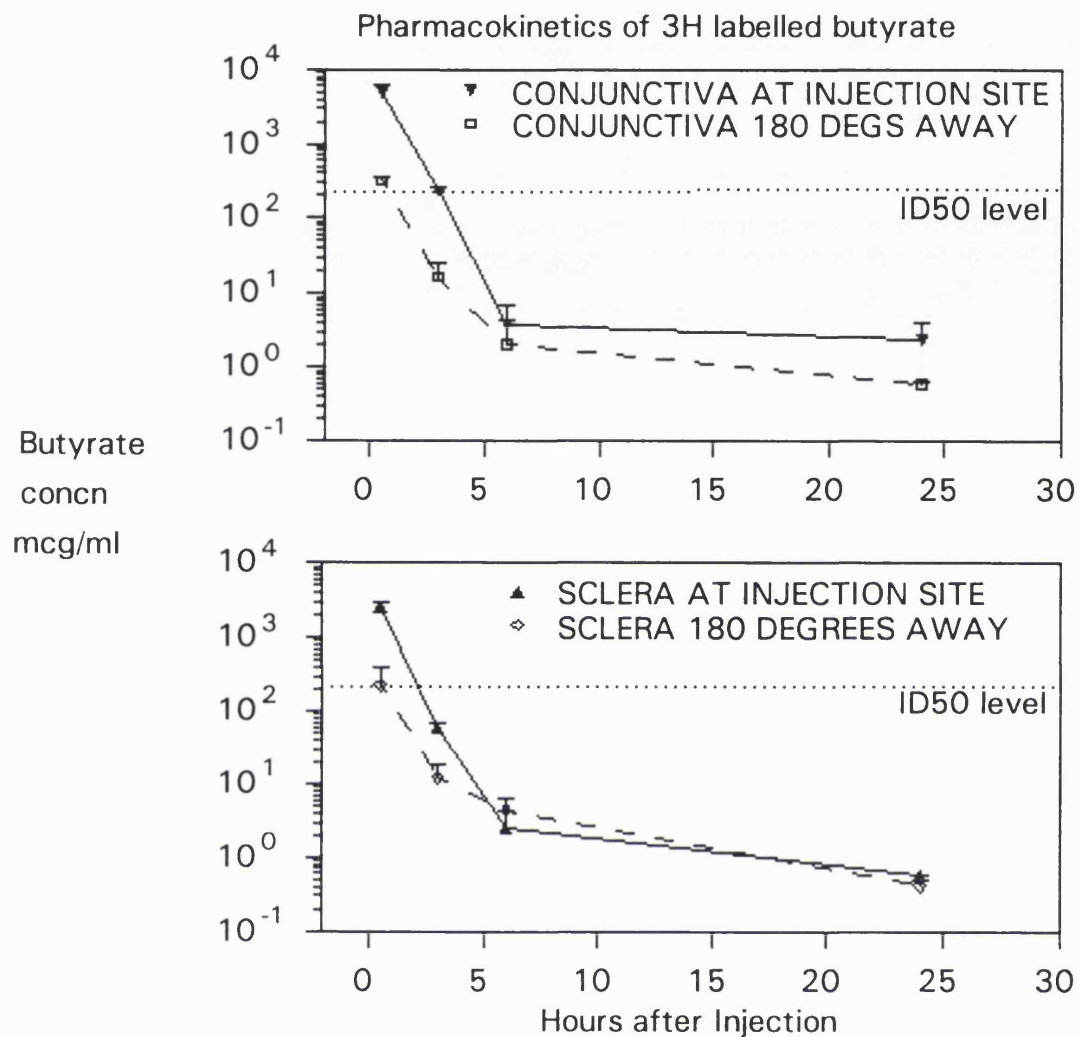
**Day 36** after treatment with high concentrations of the three drugs. The cell numbers in the drug treated wells were significantly reduced compared with the distilled water treated control cells. There was marked cell death with mitomycin and 5-fluorouridine, but not with 5-fluorouracil.

Figure 46 Pharmacokinetics of  $^3\text{H}$  sodium butyrate after subconjunctival injections.



The levels of radiolabelled butyrate rapidly falls after single subconjunctival injections of high concentration butyrate. The concentrations rapidly fall below the  $\text{ID}_{50}$  level of inhibition. Error bars = SEM.

**Figure 47** Conjunctival and scleral pharmacokinetics of  $^3\text{H}$  of butyrate after subconjunctival injections at site of injection and  $180^\circ$  away.



As with the cornea and aqueous the levels of radiolabel rapidly fall after the injections. Therapeutic levels are maintained in the conjunctiva at the injection site for about 3 hours but for only 30 minutes in the conjunctiva  $180^\circ$  away. Error bars = SEM.

**Figure 48** Concentrations after subconjunctival injection of <sup>3</sup>H butyrate (4.44 mg in 0.2ml)

	Hours after subconjunctival injection			
	0.5 hour	3 hours	6 hours	24 hours
<b>Aqueous humour</b> <i>μg/ml</i>	53.4 ± 5.5	7.9 ± 1.6	1.2 ± 0.2	0.1 ± 0.01
<b>Cornea</b> <i>μg/g</i>	108 ± 32.7	14.4 ± 2.7	3.2 ± 0.7	0.5 ± 0.07
<b>Conjunctiva</b> <b>Inj site</b> <i>μg/g</i>	4767.9 ± 858.1	233.8 ± 16.1	3.9 ± 1.8	2.4 ± 0.9
<b>Conjunctiva</b> <b>180° away</b> <i>μg/g</i>	320.6 ± 15.8	16.9 ± 4.9	2.07 ± 1.4	0.6 ± 0.04
<b>Sclera</b> <b>Inj site</b> <i>μg/g</i>	2525.5 ± 262.5	59.2 ± 5.5	2.5 ± 0.9	0.6 ± 0.04
<b>Sclera</b> <b>180° away</b> <i>μg/g</i>	226.8 ± 96.2	12.2 ± 3.5	4.4 ± 1.2	0.4 ± 0.05

removed to prevent incarceration (peripheral iridectomy). The flow of aqueous was immediate upon entry into the anterior chamber and this was very rapidly followed by the formation of fibrin in the anterior chamber of the eye. After closure of the eye an accumulation of subconjunctival fluid (bleb) was seen to develop as a result of aqueous flow underneath the conjunctiva. In eyes treated with distilled water this accumulation of fluid under the conjunctiva (bleb) rapidly began to flatten over the next few days (**Figure 49**) and within 14 days all eyes treated with distilled water had flat blebs. Although the outline of the sclerostomy was still apparent the conjunctivae were completely flat and scarred down (**Figure 50**). In the eyes treated with an application of 5-fluorouracil the natural history was similar, but delayed, in that it took longer for the bleb to flatten. The eyes treated with mitomycin-c were markedly different, in that an elevated avascular bleb persisted without the flattening of the bleb area for very prolonged periods (**Figure 50**).

### **3.61 Intraocular pressure**

Distilled water treated eyes (Control Group): In the control group treated with distilled water, the mean IOP returned to baseline by day 11 (**Figure 51**).

5-Fluorouracil (50 mg/ml) treated eyes: The mean IOP in the eyes treated with 5-FU did not return to baseline until day 21. The mean IOP's in this group were significantly lower than the control group for days 5 to 18.

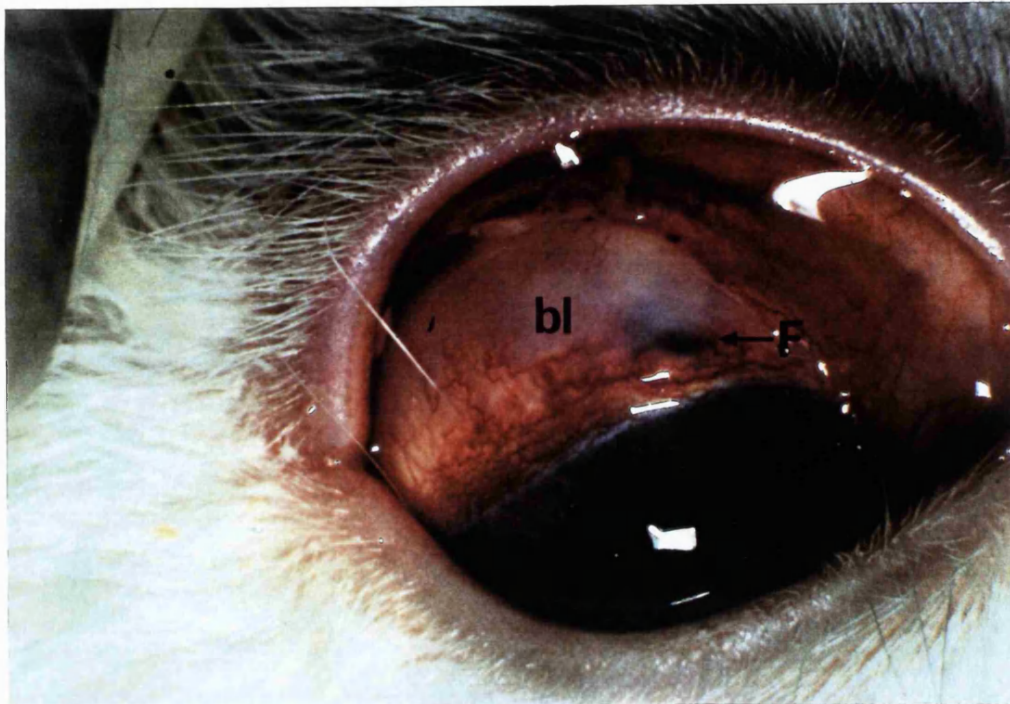
Mitomycin-c (0.2 mg/ml) treated eyes: The mean IOP of the eyes treated with the lower concentration of mitomycin-c did not return to baseline until day 30. The mean IOP in these eyes was significantly lower than the control eyes for days 5 to 18. The mean IOP in these eyes was also significantly lower than the 5-fluorouracil treated eyes on days 11 and 14.

Mitomycin-c (0.4 mg/ml) treated eyes: The mean IOP in the eyes treated with the higher concentration of mitomycin-c did not return to the baseline level during the 30 day period of the experiment. The eyes treated with 0.4 mg/ml of mitomycin-c had a significantly lower IOP than the control eyes for days 7 through 30. The IOP in eyes treated with the higher concentration of mitomycin-c was also significantly lower than the eyes treated with 5-fluorouracil (50 mg/ml) on days 7 to 30 and the eyes treated with mitomycin-c 0.2 mg/ml on days 10 to 30.

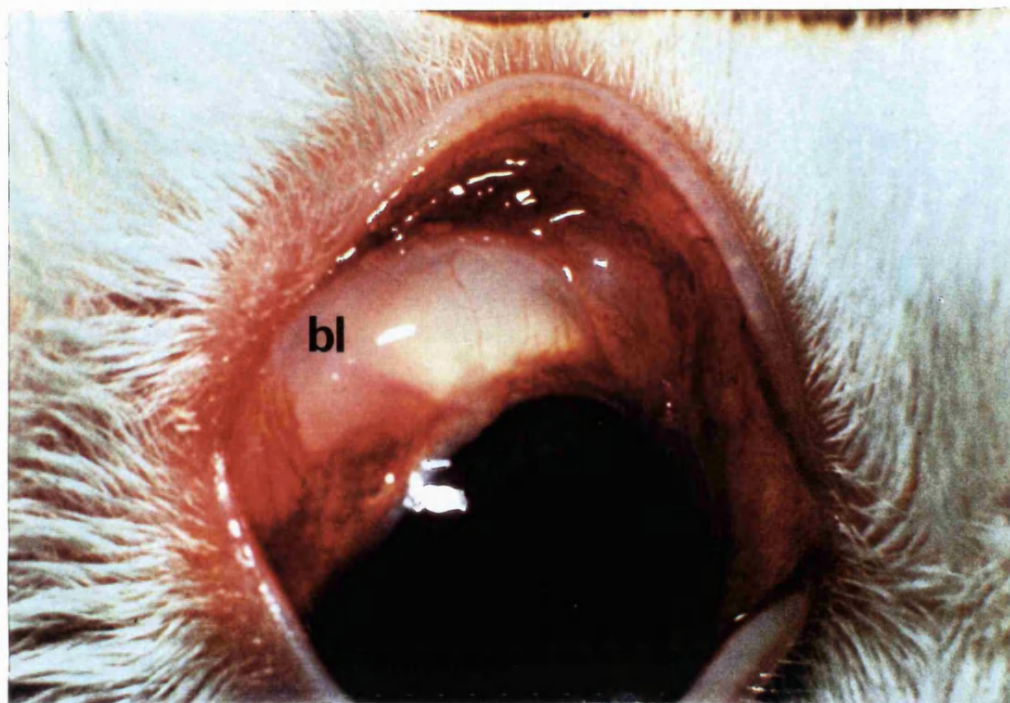
A Kaplan Meier survival plot of the duration of reduction of IOP from baseline is shown (**Figure 51**). All three treatments significantly prolonged the IOP survival



**Figure: 4-9** Appearance of rabbit eyes after creation of a sclerostomy "fistula" and treatment with distilled water or 5-FU 50 mg/ml at the time of filtration surgery.

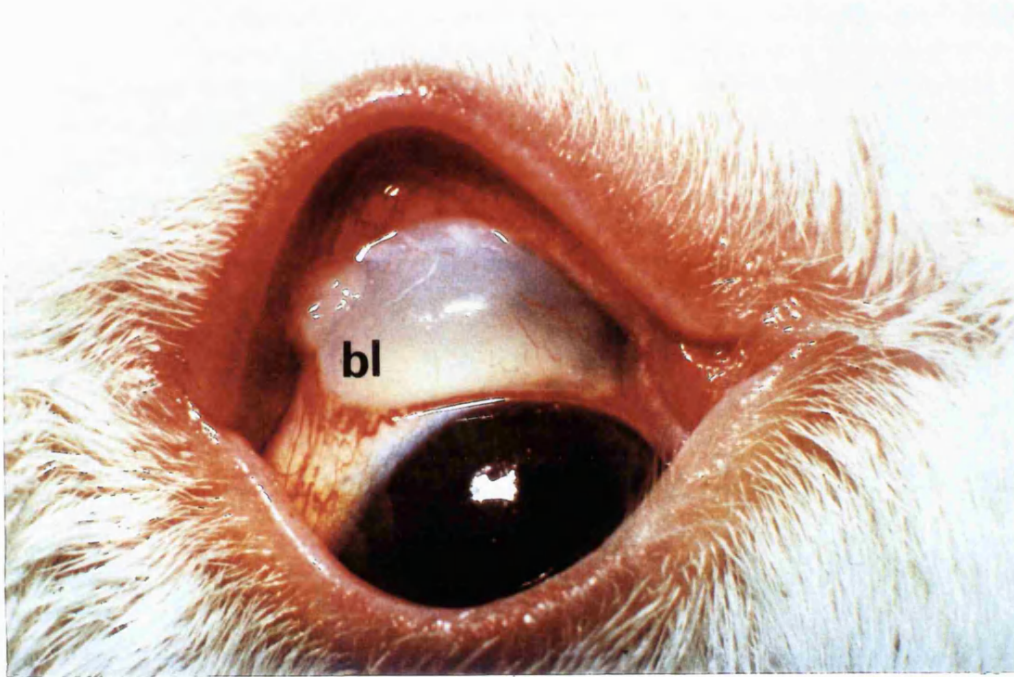


**Day 5** after surgery. 5 minute treatment with **distilled water**. The collection of aqueous humour under the conjunctiva ("bleb" = bl) is flattening as the sclerostomy "fistula" site (F) fills with granulation tissue and occludes (see histology). The conjunctiva is becoming more vascular.

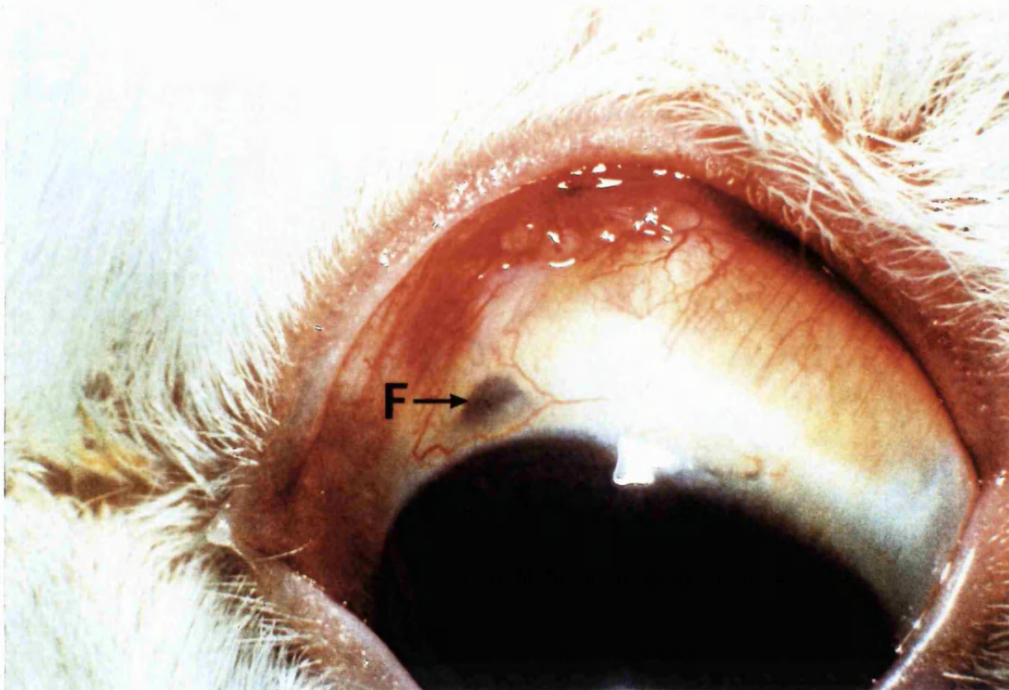


**Day 5** after surgery. 5 minute treatment with **5-FU 50 mg/ml**. There is still a marked collection of aqueous under the conjunctiva ("bleb" = bl). The conjunctiva over the bleb is relatively avascular.

**Figure: 50** Appearance of rabbit eyes after creation of a sclerostomy "fistula" and treatment with MMC 0.4 mg/ml or distilled water at the time of filtration surgery.

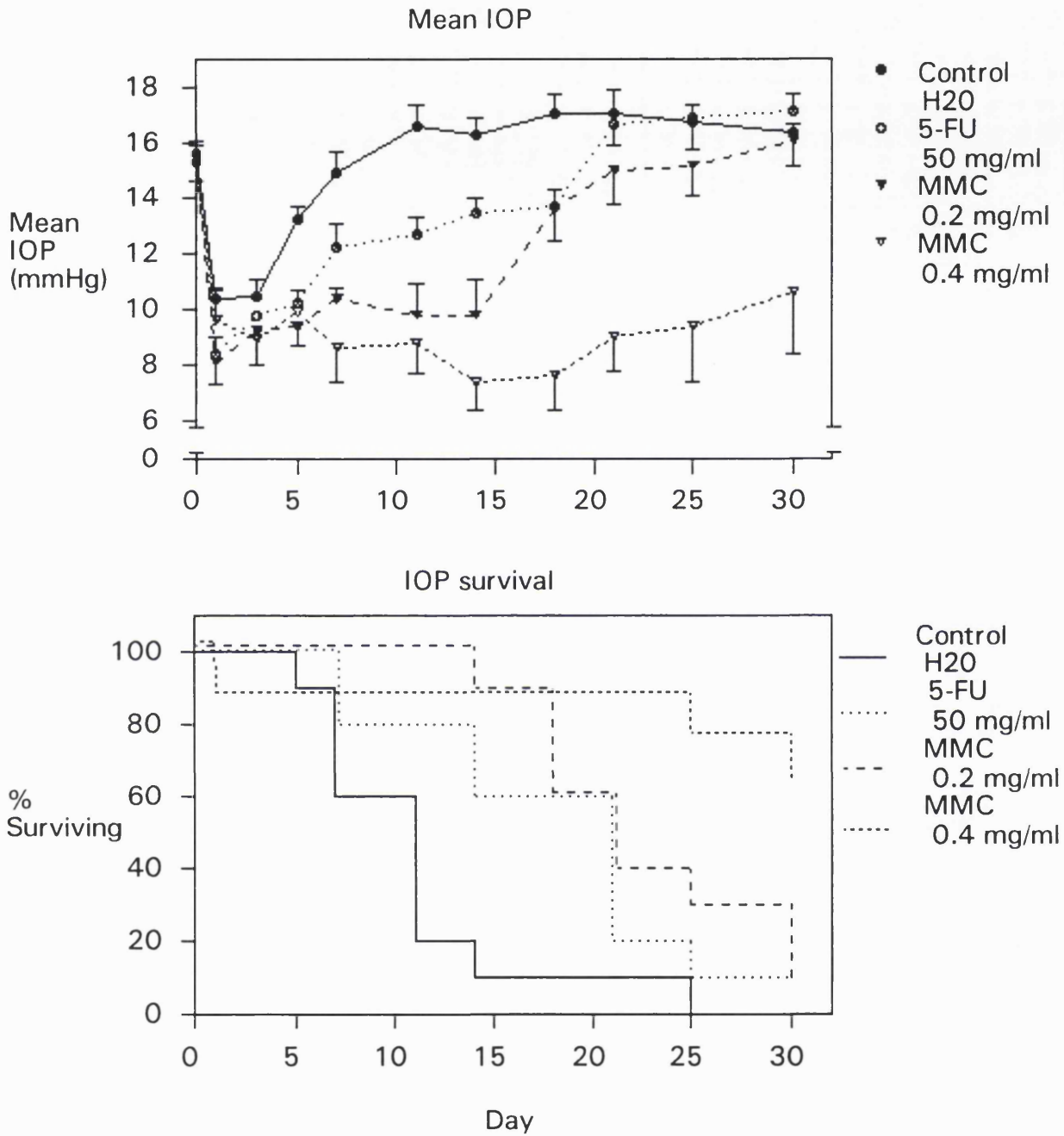


**Day 30** after surgery. 5 minute treatment with **MMC 0.4 mg/ml**. There is still a prominent collection of aqueous under the conjunctiva ("bleb" = bl) and the intraocular pressure is still low. The drainage bleb is thin and avascular.

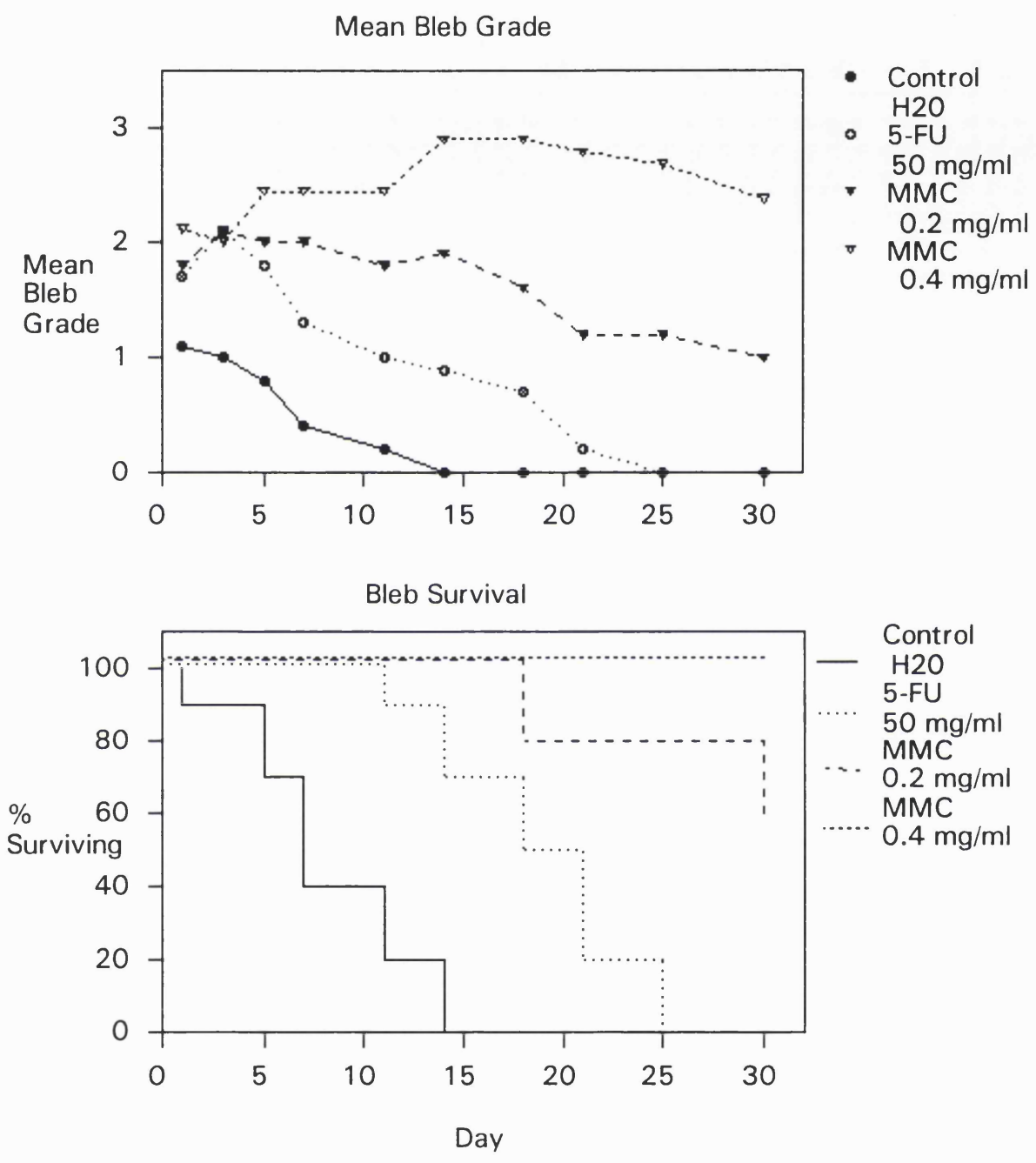


**Day 30** after surgery. 5 minute treatment with **distilled water**. There is no aqueous under the conjunctiva which is flat, although the outline of the sclerostomy "fistula" (F) is still visible. The intraocular pressure has returned to normal. The appearance was very similar for 5-FU treated eyes at 30 days.

**Figure 51** Graphs of 1) intraocular pressure in different treatment groups over 30 days following "fistulising" surgery. Error Bars = SEM 2) Kaplan-Meier survival curves for intraocular pressure (failure = return of IOP to baseline).



**Figure 52** Graphs of 1) mean bleb grade in different treatment groups over 30 days following "fistulising" surgery. 2) Kaplan-Meier survival curves for blebs (failure = flat bleb).



compared to the control distilled water treated eyes ( $p < 0.05$ ). There was no significant difference in IOP survival between the 5-fluorouracil and the mitomycin-c 0.2 mg/ml group, but the mitomycin-c 0.4 mg/ml group survival was significantly longer than both the 5-fluorouracil ( $p < 0.008$ ) and the mitomycin-c 0.2 mg/ml group ( $p < 0.017$ ).

### **3.62 Bleb grading.**

Distilled water treated eyes (Control group): All blebs were graded as flat by day 14 in the control group (**Figure 52**).

5-Fluorouracil (50 mg/ml) treated eyes: All the 5-fluorouracil blebs were graded flat by day 25. The mean bleb grading in the 5-fluorouracil treated eyes was significantly higher than the control group on days 3 to 18.

Mitomycin-c (0.2 mg/ml) treated eyes: At day 30 four of the ten blebs (40%) were graded as flat in the mitomycin-c 0.2 mg/ml group. The bleb grading in the mitomycin-c 0.2 mg/ml eyes was significantly higher than the control group throughout the duration of the experiment (day 1 through 30), and was also significantly higher than the 5-fluorouracil treated eyes from day 7 to 30.

Mitomycin-c (0.4 mg/ml) treated eyes: None of the remaining eight eyes treated with mitomycin-c 0.4 mg/ml (one eye that developed endophthalmitis was excluded at day 30) had flat blebs at day 30. The bleb grading in the mitomycin-c 0.4 mg/ml group was significantly higher than the 5-fluorouracil treated eyes from day 7 through 30, and the mitomycin-c 0.2 mg/ml group from days 14 through 30.

Bleb survival for the four groups are shown in **Figure 52**. Bleb survival was significantly prolonged in the 5-fluorouracil and both mitomycin-c groups compared with the control group ( $p < 0.0003$ ). Bleb survival was also significantly longer in the mitomycin-c groups compared to the 5-fluorouracil group ( $p < 0.006$ ), and in the mitomycin-c 0.4 mg/ml group compared with the mitomycin-c 0.2 mg/ml group ( $p < 0.05$ ). Examples of the differing drainage blebs are shown in **Figures 49 and 50**.

### **3.63 Histology**

In eyes treated with distilled water (control) taken five days after surgery, many of the sclerostomy "fistula" sites had been closed with new granulation tissue. The entire wound area was hypercellular both in the closed sclerostomy area and the

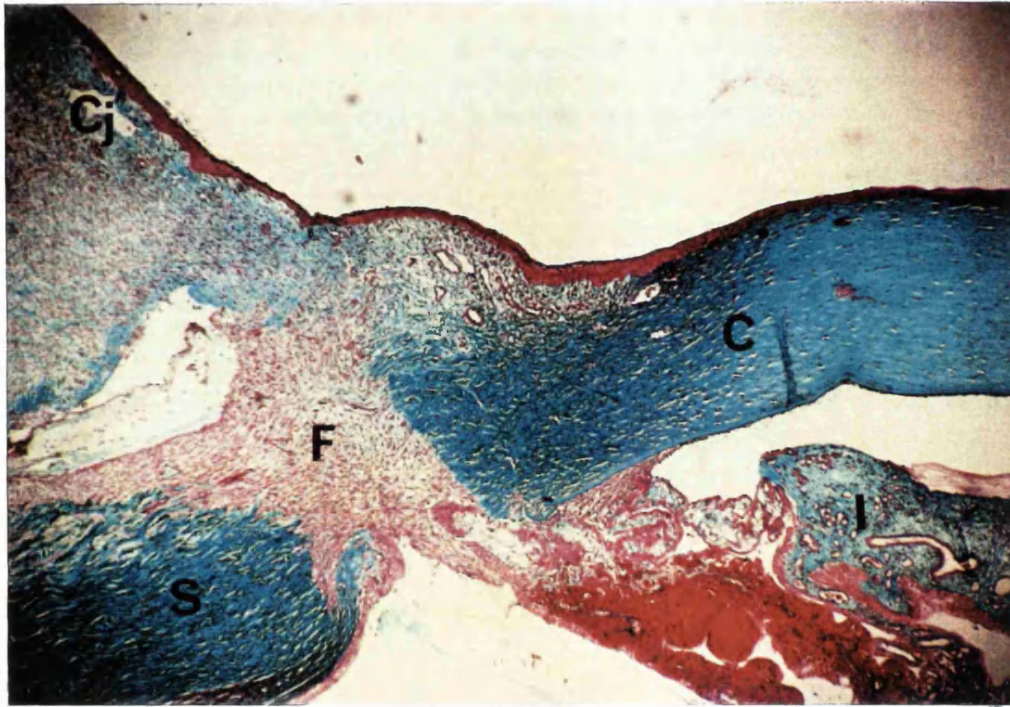
subconjunctival space (**Figure 53**). In contrast there was much less granulation tissue in the 5-fluorouracil treated eyes and virtually no granulation tissue in the eyes treated with both concentrations of mitomycin-c. The cellularity of the 5-fluorouracil and mitomycin-c treated eyes was also apparently reduced compared to the control eyes. The subconjunctival tissue appeared somewhat thinner in the 5-fluorouracil treated eyes and very thin in the mitomycin-c treated eyes compared to the distilled water treated control eyes (**Figures 53 and 54**).

At thirty days the sclerostomies in all the distilled water treated eyes and the 5-fluorouracil treated eyes that were examined were closed' and there was scar tissue in the subconjunctival space. In the mitomycin-c treated eyes examined the sclerostomies were patent and there was minimal scar tissue in the subconjunctival space (**Figure 55**).

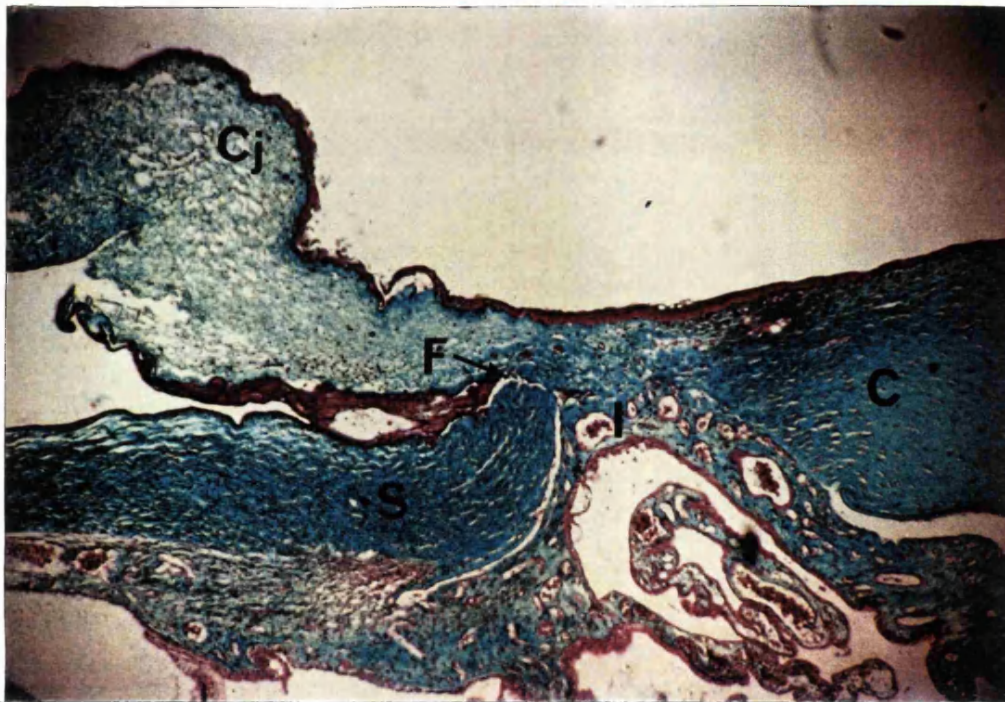
### **3.64 Complications**

There was no detectable corneal staining with fluorescein at any stage in any of the animals. The 5-fluorouracil blebs were more avascular than the control blebs in the first two weeks. The mitomycin-c blebs were noticeably thinner and much more avascular than the blebs in both the control and the 5-fluorouracil treated eyes (**Figures 49 and 50**). Three of the eyes treated with mitomycin-c 0.4 mg/ml developed complications. One of the animals with a high thin bleb developed a presumed leak on post operative day 25 as evidenced by a flat bleb and a soft eye. However, no obvious hole could be visualised nor could a positive Seidel's test (dilution of a fluorescein placed in the tear film, and viewed with a cobalt blue light) be detected on slit lamp microscope examination. The bleb reformed by the next day with a recorded intraocular pressure of 6 mmHg. Another eye developed an area of corneal opacification adjacent to the treated area on day 7 which resolved by day 21. This was associated with corneal neovascularisation in the same area which also resolved by day 21. The third animal was noted to have an endophthalmitis (inflammation due to infection within the eye) on day 30 with pus localised to the anterior segment filling the bleb and the anterior chamber.

Figure: 53 Histology of rabbit eyes after treatment with distilled water or 5-FU 50 mg/ml at the time of filtration surgery.



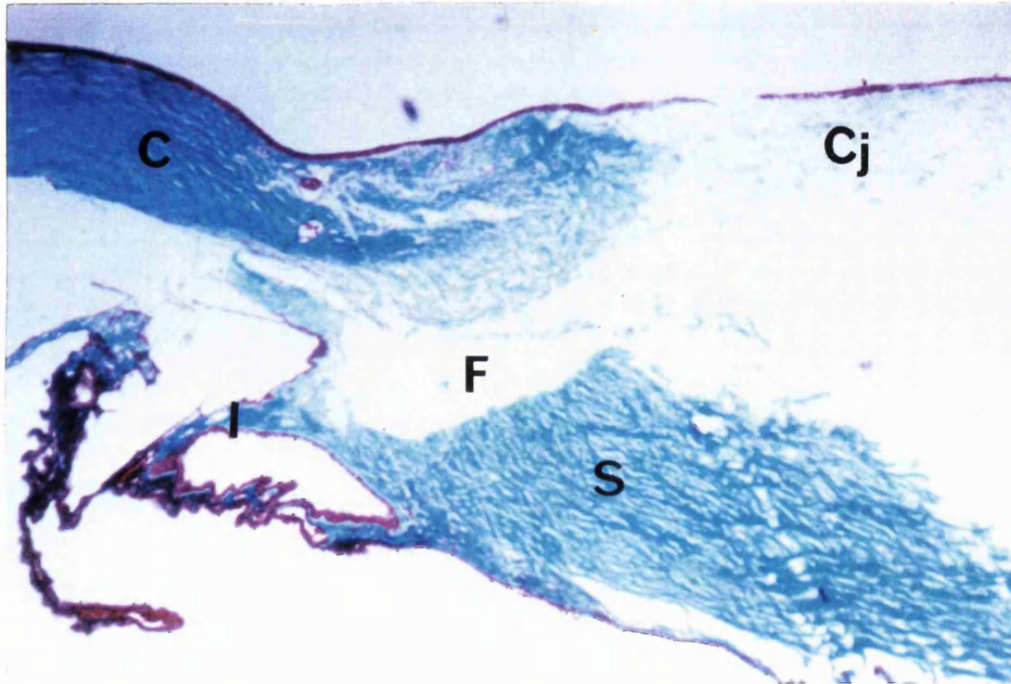
Day 5 after surgery. 5 minute treatment with **distilled water**. The sclerostomy "fistula" site has been closed with new granulation tissue. The entire wound area is hypercellular both in the closed sclerostomy area and the subconjunctival space. Magnification X 40.



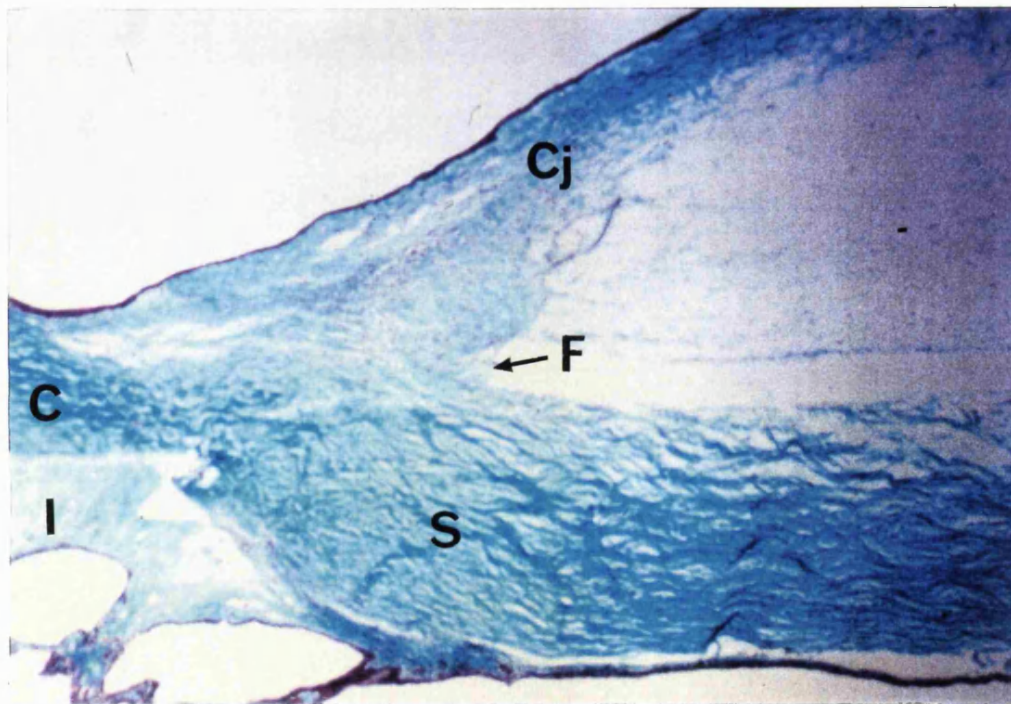
Day 5 after surgery. 5 minute treatment with **5-FU 50 mg/ml**. Sclerostomy is narrow with iris prolapsed into sclerostomy but is still patent. Minimal new granulation tissue in the subconjunctival space. Magnification X 40.

C = Cornea Cj = Conjunctiva S = Sclera I = Iris F = Sclerostomy "fistula"

Figure: 54 Histology of rabbit eyes after treatment with MMC 0.4 mg/ml or 5-FU 50 mg/ml at the time of filtration surgery.



Day 5 after surgery. 5 minute treatment with **MMC 0.4 mg/ml**. The sclerostomy "fistula" is wide open and there is virtually no new granulation tissue. The entire wound area is hypocellular both around the sclerostomy area and in the subconjunctival space. Magnification X 40.

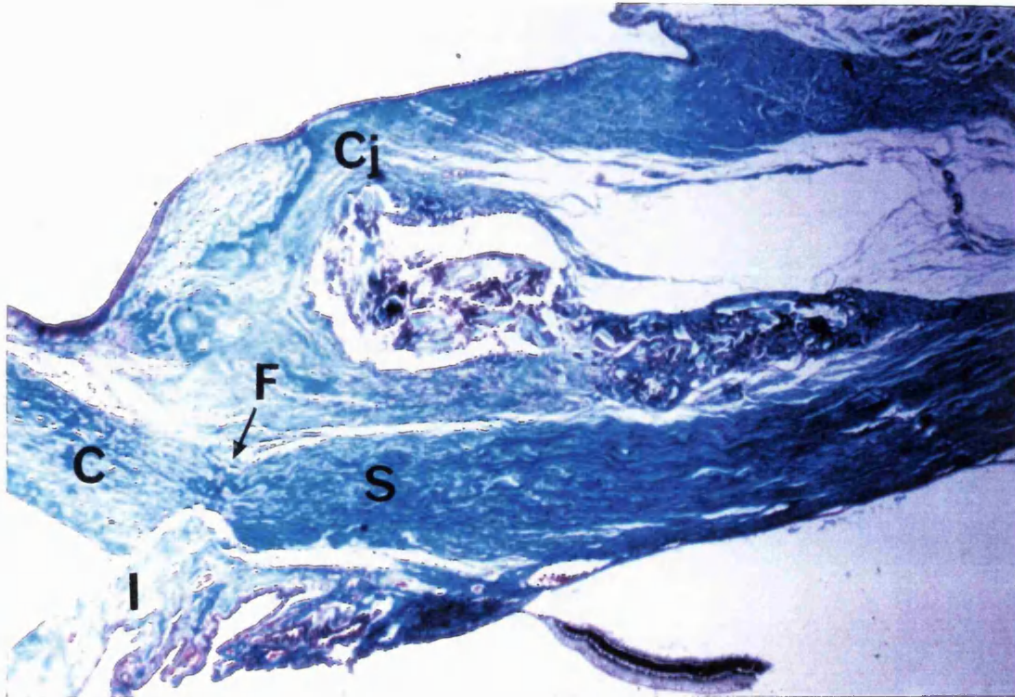


Day 10 after surgery. 5 minute treatment with **5-FU 50 mg/ml**. The sclerostomy "fistula" is closed in part of its length by new scar tissue. There is an increase in cellularity in the subconjunctival area. Magnification X 40.

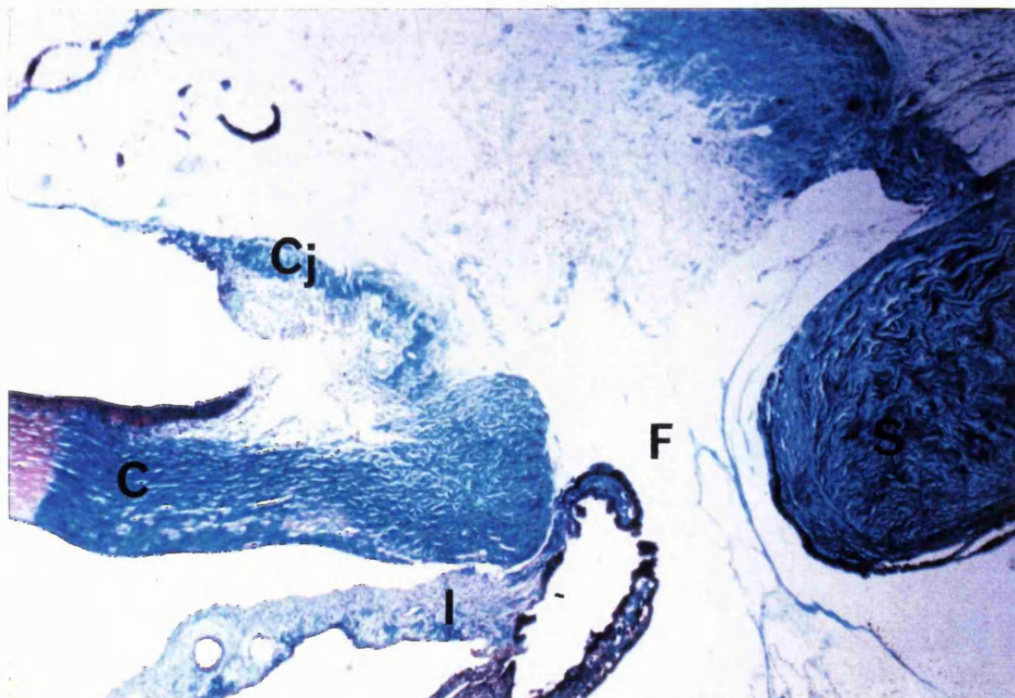
C = Cornea Cj = Conjunctiva S = Sclera I = Iris F = Sclerostomy "fistula"



**Figure: 55** Histology of rabbit eyes after treatment with distilled water or MMC 0.4 mg/ml at the time of filtration surgery.



**Day 30** after surgery. 5 minute treatment with **distilled water**. The sclerostomy "fistula" is closed and the subconjunctival space is filled with new scar tissue. The appearance of the 5-FU treated eyes was similar with closed sclerostomy "fistulas" and subconjunctival scar tissue. Magnification X 40.



**Day 30** after surgery. 5 minute treatment with **MMC 0.4 mg/ml**. The sclerostomy "fistula" is wide open throughout its length, and there is very little new scar tissue except at the untreated posterior part of the conjunctiva. Magnification X 40.

C = Cornea Cj = Conjunctiva S = Sclera I = Iris F = Sclerostomy "fistula"

### **3.7 Long term effects of short single dose antiproliferatives on local and distant tissue fibroblasts**

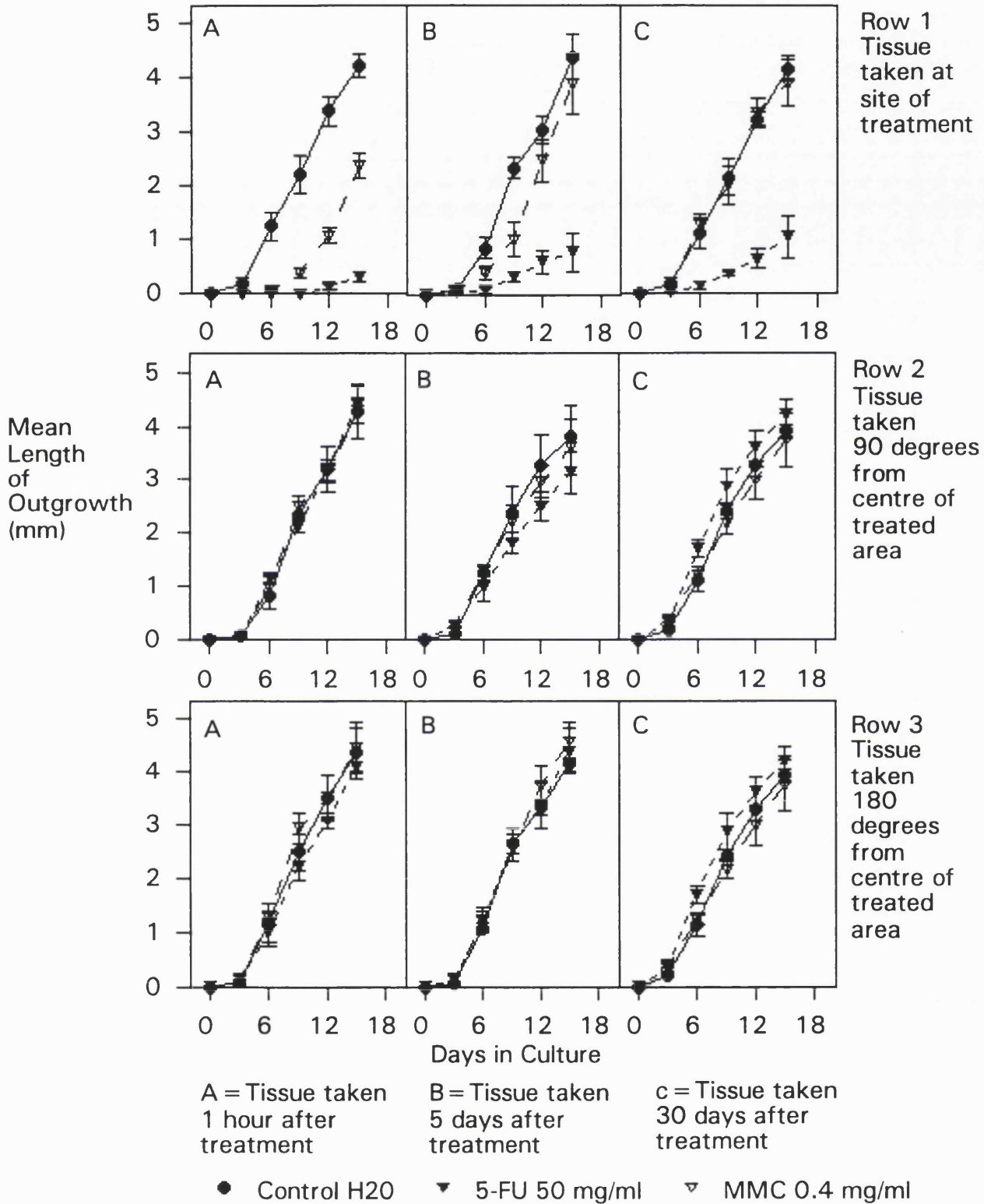
#### **3.71 Subconjunctival tissue fibroblast outgrowths**

Control (distilled water treated eyes): In the samples taken from the distilled water treated area (**Figure 56 and 57**), fibroblasts began to grow out after about 6 days in culture, after which there was a rapid increase in average outgrowth throughout the experiment to day 15. The fibroblast outgrowth rate during 15 days in culture was similar for tissue samples taken 90 and 180 degrees from the center of the treated area (3 o'clock and 6 o'clock position). The outgrowth rate was similar for the samples taken at one hour, 5 days and 30 days after the filtering procedure.

5-Fluorouracil 50 mg/ml treated eyes: The average fibroblast outgrowth (referred to as outgrowth from here onwards) from the 5-fluorouracil treated tissues taken one hour after surgery (**Figure 57**) was significantly less than the distilled water treated area outgrowth on culture days 6 through 15, although by day 15 in culture the rate of outgrowth was similar to the distilled water treated cells. In the tissues taken 5 days after surgery, the 5-fluorouracil treated outgrowth was only significantly different on day 9, after which there was no significant difference from the control treated tissues. In the tissues taken thirty days after surgery there was no significant difference in the outgrowths between the 5-fluorouracil treated area and the control treated area. The outgrowths from the tissues 90 and 180 degrees from the center of the treated area were not significantly different from the control treated eyes. Although the outgrowths from the 5-fluorouracil treated areas were delayed in the tissues taken one hour and 5 days after treatment, the appearances of the cells growing out were normal (**Figure 57**).

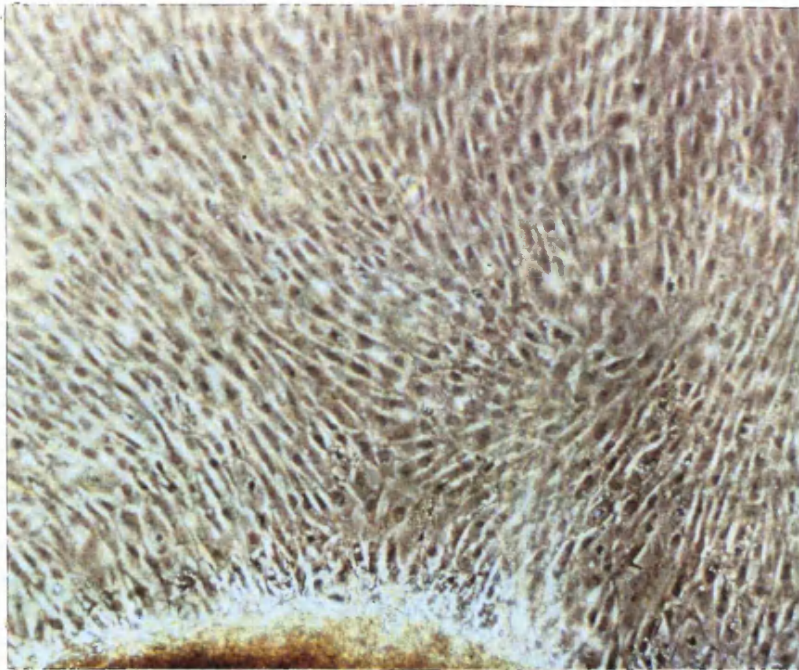
Mitomycin-c 0.4 mg/ml treated eyes: The average fibroblast outgrowth from the mitomycin-c treated subconjunctival tissues (**Figure 56 and 57**) was significantly less than the outgrowth from the distilled water treated eyes from experiment days 6 to 15 in tissues taken one hour, 5 days and 30 days after surgery. The outgrowth was slightly greater in tissues taken after 30 days compared to the outgrowths from tissues taken one hour and 5 days after surgery, but were still markedly reduced compared with the distilled water treated tissues. In addition to the difference in outgrowth, the growth rate in the mitomycin-c treated tissues never equalled the growth rate of the distilled water treated tissues. The outgrowths from the areas 90 and 180 degrees

**Figure 56** Graphs of fibroblast outgrowths from conjunctival biopsies taken one hour, 5 days and 30 days after surgery with intraoperative water (control), 5-fluorouracil 50 mg/ml and mitomycin-c 0.4 mg/ml at the site of treatment, 90° and 180° from centre of treated area.



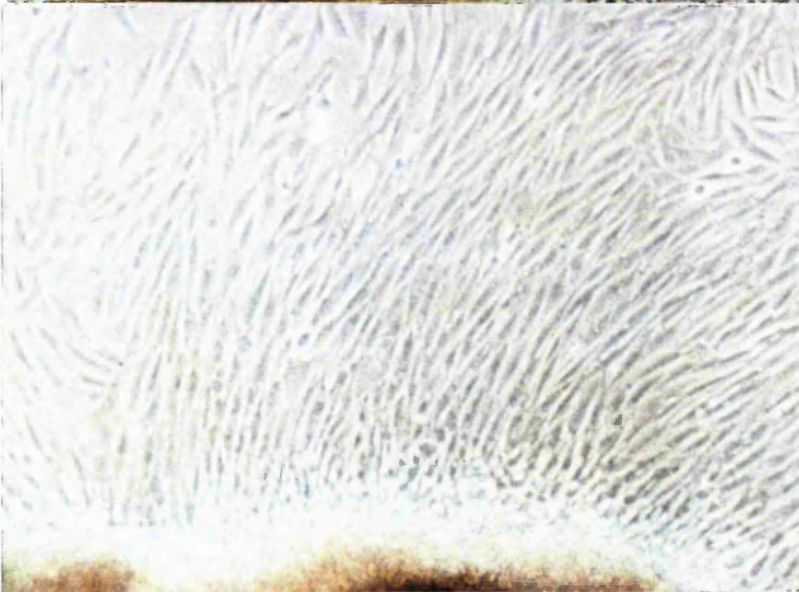
The outgrowths from the 5-fluorouracil treated tissues are temporarily inhibited, but return to normal, whereas the outgrowths from the mitomycin-c treated areas do not return to normal. The outgrowths from adjacent areas were normal. Error bars = SEM.

**Figure: 57** Fibroblast outgrowths from subconjunctival tissue biopsied five days after exposure to distilled water, 5-FU 50 mg/ml or MMC 0.4 mg/ml for 5 minutes at the time of operation.



**Distilled water treated tissue (Control)**

Cells rapidly grew out of explant to rapidly cover the tissue culture well. Cells were small and spindle shaped with multiple mitotic figures. Magnification X 400



**5-FU 50 mg/ml treated tissue.**

The cell outgrowth was initially delayed. However, when the cells began growing out they were spindle shaped and appeared normal. The rate of outgrowth was then normal. Regular mitotic figures were seen. Magnification X 400.



**MMC 0.4 mg/ml treated tissue**

The cell outgrowth was delayed. When cell outgrowth began the cells were markedly abnormal, with considerable variation in cell size, and vacuolated cells. The cells never became confluent, and the growth rate never equalled that of the control cells.

from the centre of the treated area were not significantly different from the outgrowths from tissues taken from a similar area in distilled water treated eyes. The mitomycin-c outgrowths were also significantly smaller than the 5-fluorouracil outgrowths from tissues taken at one hour (days 12 and 15 in culture), 5 days (days 9, 12 and 15 in culture) and 30 days (days 6, 9, 12, and 15 in culture). The cells growing out from the mitomycin-c treated areas were markedly abnormal being vacuolated, large in size and less confluent than cells from the distilled water treated tissues (**Figure 57**).

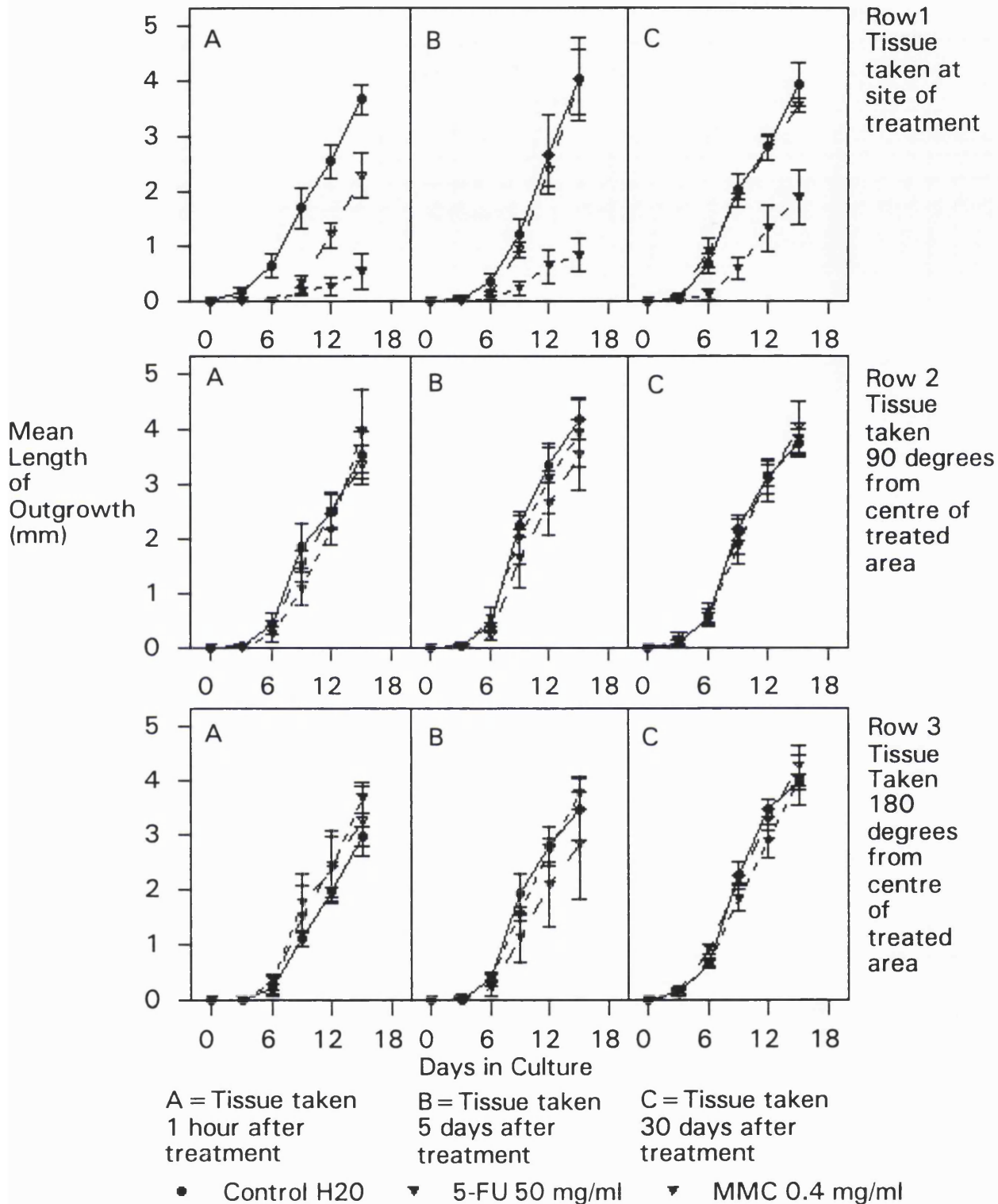
### **3.72 Scleral tissue fibroblast outgrowths**

Distilled water treated eyes: In the tissue samples taken from the distilled water treated area, fibroblasts began to grow out after about 9 days in culture (**Figure 58**), after which there was a rapid increase in outgrowth area throughout the culture period to day 15. The fibroblast outgrowth rate was similar for tissue samples taken 90 and 180 degrees from the centre of the treated region (3 o'clock and 6 o'clock position). The outgrowth rate was similar for the samples taken at one hour, 5 days and 30 days after the filtering procedure.

5-Fluorouracil 50 mg/ml treated eyes: The average fibroblast outgrowth from the 5-fluorouracil treated scleral areas taken one hour after surgery was significantly less than the distilled water treated area outgrowth on culture days 6 to 15, although by the day 12 in culture the rate of outgrowth had become similar to the distilled water treated cells (**Figure 58**). In the tissues taken 5 days and 30 days after surgery, there was no significant difference in the outgrowth from 5-fluorouracil treated tissues compared with the outgrowth from the distilled water treated tissues. The outgrowths from the areas 90 and 180 degrees from the centre of the treated area were not significantly different from the control treated eyes at any time point. The appearance of the cells growing out from the centre of the 5-fluorouracil treated area were normal (**Figure 57**).

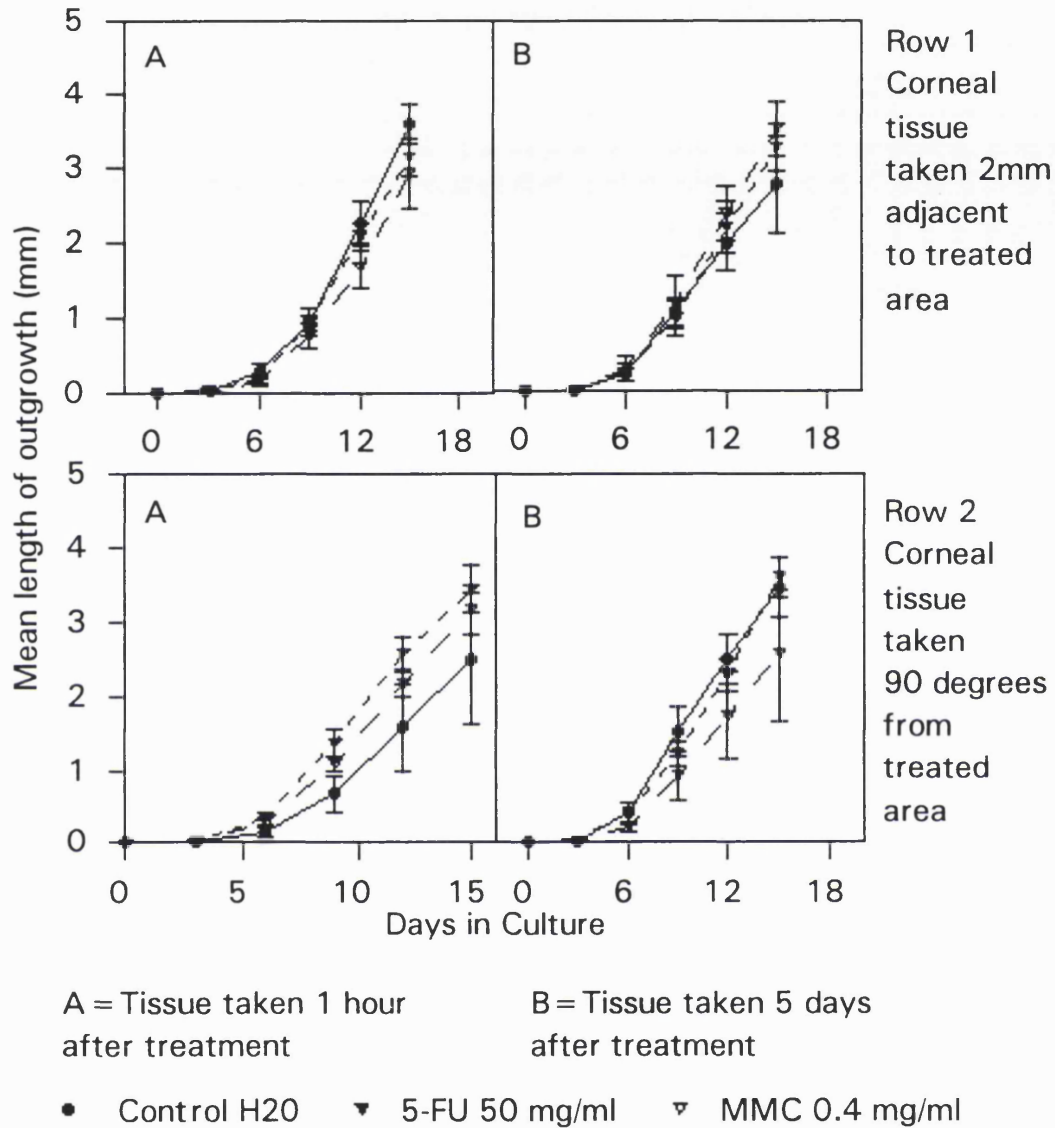
Mitomycin-c 0.4 mg/ml treated eyes: There were significant differences in the outgrowth from the mitomycin-c treated scleral tissues compared with the distilled water treated tissues taken one hour (days 6 to 15 in culture), 5 days (days 9 to 15 in culture) and 30 days (days 9 to 15 in culture) after surgery (**Figure 58**). The outgrowth was slightly greater in tissues taken 30 days after surgery compared to the outgrowths from tissues taken one hour and 5 days after surgery.

**Figure 58** Graphs of fibroblast outgrowths from scleral biopsies taken one hour, 5 days and 30 days after surgery with intraoperative water (control), 5-fluorouracil 50 mg/ml and mitomycin-c 0.4 mg/ml at the site of treatment, 90° and 180° from centre of treated area.



The outgrowths from the 5-fluorouracil treated tissues are temporarily inhibited, but return to normal, whereas the outgrowths from the mitomycin-c treated areas do not return to normal. The outgrowths from adjacent areas were normal. Error bars = SEM.

**Figure 59** Graphs of fibroblast outgrowths from corneal biopsies taken one hour, 5 days and 30 days after surgery with intraoperative water (control), 5-fluorouracil 50 mg/ml and mitomycin-c 0.4 mg/ml at the site of treatment, 90° and 180° from center of treated area.



All the outgrowths were entirely normal. Error bars = SEM.

In addition to the difference in average outgrowth, the growth rate in the mitomycin-c treated tissues never equalled the growth rate of the distilled water treated tissues. The outgrowths from the areas 90 and 180 degrees from the centre of the treated area were not significantly different from the outgrowths from tissues taken from a similar area in distilled water treated eyes. The mitomycin-c outgrowths were also significantly smaller than the 5-fluorouracil outgrowths in tissues taken at one hour (days 12 and 15 in culture), 5 days (days 12 and 15 in culture) and 30 days (days 6, 9, 12, and 15 in culture). The cells growing out from the mitomycin-c treated areas were markedly abnormal being vacuolated, multinucleated, variable in size and non-confluent compared with the cells from the distilled water treated tissues (**Figure 57**).

### **3.73 Corneal tissue fibroblast outgrowths**

There was no statistically significant difference in the fibroblast outgrowths from corneal tissue taken from eyes treated with 5-fluorouracil, mitomycin-c or distilled water one hour or 5 days after surgery (**Figure 59**).

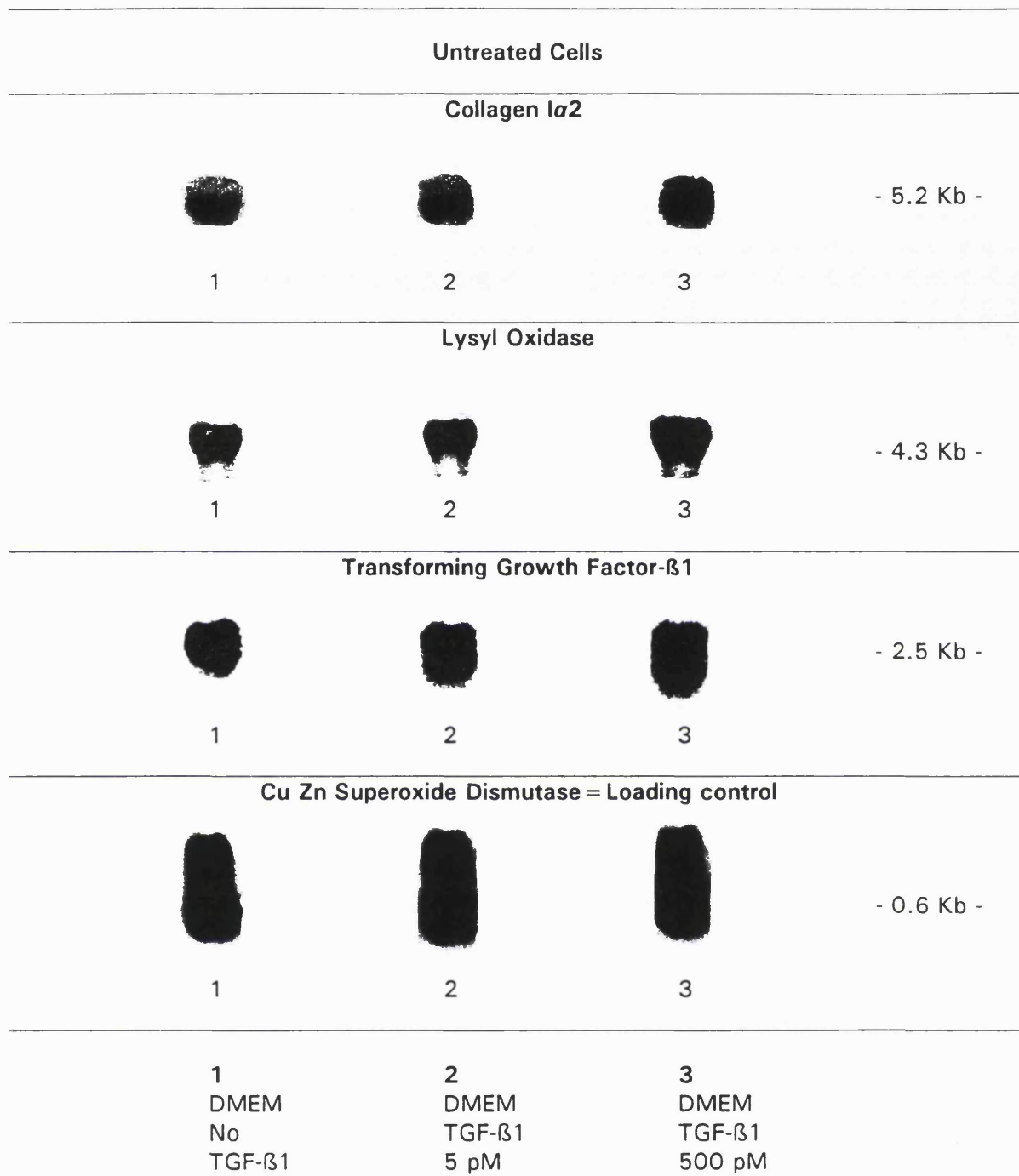
### **3.8 Effects of transforming growth factor- $\beta$ 1 on RNA levels of collagen, lysyl oxidase, and transforming growth factor- $\beta$ 1 and effects of growth arresting drug treatment**

After 36 hours of being left in serum free media the cells were examined under the microscope. They retained normal spindle shaped morphology without any abnormalities such as vacuolation or cell rounding. The cells treated with the 3 concentrations of TGF- $\beta$ 1 did not show any overt differences in cellular morphology over the 48 hours of treatment. TGF- $\beta$ 1 at a concentration of 500 pMolar increased the RNA levels of Collagen  $I\alpha$ 2, lysyl oxidase and TGF- $\beta$ 1 in human Tenon's capsule fibroblasts. Relative to copper zinc superoxide dismutase (Cu Zn SOD) RNA levels which were used as a loading control, the densitometry increased 2.3 times for collagen, 1.51 times for lysyl oxidase, and 1.49 times for TGF- $\beta$ 1. There was no increase in the RNA level of Cu Zn SOD. There were also very slight increases in collagen  $I\alpha$ 2 (1.06) and TGF- $\beta$ 1 (1.11) RNA levels when the cells were treated with TGF- $\beta$ 1 at a concentration of 5 pMolar (**Figure 60**).

Following growth arrest induced with 5-fluorouracil the fibroblasts still showed an increase in RNA levels for collagen  $I\alpha$ 2 (2.14), lysyl oxidase (2.2) and TGF- $\beta$ 1 (1.46)

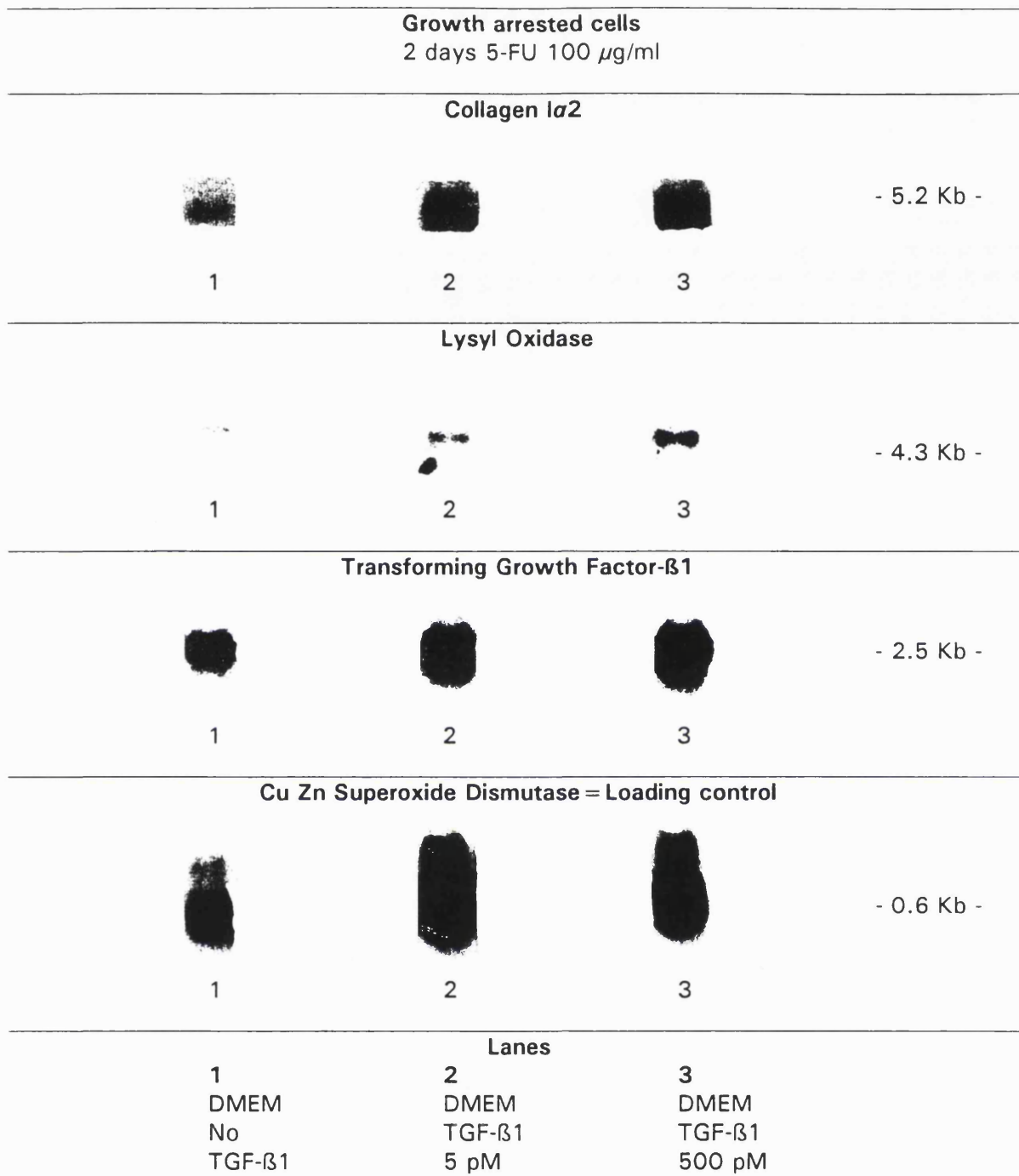


**Figure 60** Effects of TGF- $\beta$ 1 stimulation on RNA levels of collagen, lysyl oxidase and TGF- $\beta$ 1 in Tenon's capsule fibroblasts.



RNA levels of collagen 1 $\alpha$ 2, lysyl oxidase and TGF- $\beta$ 1 all showed an increase when treated with 500 pM of TGF- $\beta$ 1.

**Figure 61** Effects of TGF- $\beta$ 1 stimulation on RNA levels of collagen, lysyl oxidase and TGF- $\beta$ 1 on growth arrested Tenon's capsule fibroblasts.



NB: Lane 1 underloaded.

The cells growth arrested with 5-fluorouracil also showed relatively normal RNA levels of collagen and TGF- $\beta$ 1, with an increase when stimulated with TGF- $\beta$ 1. However, the levels of lysyl oxidase were markedly reduced, although there was still a response to stimulation with TGF- $\beta$ 1.

after treatment with 500 pMolar TGF- $\beta$ 1 even after the cells had been growth arrested. However, the absolute levels of lysyl oxidase appeared markedly reduced after 2 days treatment and growth arrest (**Figure 61**).

## CHAPTER 4 DISCUSSION

### 4.1 The role of aqueous and stimulatory factors

#### 4.11 Role of aqueous in the healing process

The glaucoma filtration procedure differs from other surgical wounds in that the site of filtration surgery is bathed with aqueous humour. This fluid can have profound effects on the healing process. Although conjunctiva dissected from the underlying sclera rapidly scars down, if there is aqueous under the conjunctiva and Tenon's capsule this scarring down does not usually occur in elderly Caucasian patients. In neovascular glaucoma, in which the aqueous contains stimulatory factors promoting new vessel growth, glaucoma filtration surgery invariably fails.

It has been postulated that the aqueous is not stimulatory to fibroblasts (Albrink and Wallace, 1951; Kornblueth and Tenenbaum, 1956) and may actually have a degenerative effect on tissue (Chi et al, 1960) although the degenerative effects have not been substantiated (Addicks et al, 1983). Herschler has also postulated the presence of an inhibitory factor in the aqueous humour which prevents fibroblast proliferation, this inhibitory factor being present in normal aqueous humour but absent in some patients with glaucoma (Herschler et al, 1980; Herschler, 1981). On the other hand, Burke and colleagues have found that primary aqueous humour stimulated mitogenic activity of human Tenon's capsule fibroblasts (Burke et al, 1982) and Jiang and coworkers noted both a promotion and inhibition of cell proliferation (Jiang et al, 1983).

#### 4.12 Aqueous from eyes with glaucoma and cataract

Apart from the effects on fibroblast proliferation, aqueous also stimulates fibroblast chemotaxis. Joseph and colleagues (1989a) found that human aqueous humour taken before surgery (primary aqueous) from patients undergoing cataract surgery was also chemoattractant to rabbit ocular fibroblasts. Our data confirmed that human aqueous humour also stimulated human Tenon's capsule fibroblast chemotaxis, and that this was primarily a chemotactic rather than a chemokinetic phenomenon as assayed using the chequerboard design. Therefore aqueous as a biological fluid is potentially able to induce a directed migration of human Tenon's fibroblasts. This may be clinically important as experimental histology suggests that fibroblasts migrate into

the wounded area after filtration surgery (Miller et al, 1989; Miller et al, 1990). However, there was no significant difference in the average number of cells migrated to aqueous from cataract controls and patients with primary open angle glaucoma. Herschler has postulated the presence of an inhibitory factor in the aqueous humour which prevent fibroblast proliferation, this inhibitory factor being present in normal aqueous humour but being absent in some patients with glaucoma (Herschler, 1981; Herschler et al, 1980). Only a few naturally occurring cytokines are known to inhibit fibroblast proliferation and these are TGF- $\beta$  (Sporn and Roberts, 1988), tumour necrosis factor (Old, 1985) and interferon (Lin et al, 1986). This inhibition may be related to specific genes expressed under conditions of growth arrest (Schneider et al, 1988; Whyte et al, 1988). If a putative inhibitory factor is present, it does not appear to significantly affect migration as opposed to proliferation in the aqueous of the patients tested in our experiments. There is virtually no data in the literature on biological substances which primarily affect cellular migration without affecting other cellular functions.

#### **4.13 Role of fibronectin component**

The role of the fibronectin found in the aqueous humour is uncertain, and in particular its contribution to the chemoattractant activity of the aqueous humour. We chose to investigate the role of fibronectin in the stimulatory activity in the aqueous for a variety of reasons. Joseph and colleagues also partially characterised the nature of the chemoattractants in human aqueous humour (Joseph et al, 1989b). He found the majority of substances responsible for the chemoattractant activity of the aqueous had a molecular weight greater than 30,000, were deactivated by low pH but retained activity at high pH and had both heat labile and heat stable components after boiling (Joseph et al, 1989a). Furthermore in subsequent experiments he also separately found that fibronectin stimulated ocular fibroblast chemotaxis (Joseph et al, 1987).

Fibronectin is a ubiquitous high molecular weight adhesive glycoprotein which is found in all tissues (Furcht, 1983; Yamada and Kennedy, 1985). Fibronectin is a very important component of many cell matrix interactions in the human body, with multiple binding sites which bind to a wide variety of substances including type I-IV collagen, thrombospondin (Lahav et al, 1984) fibrin, dermatan and chondroitin sulphate, heparan and heparin sulphate proteoglycans (Ruoslahti et al, 1981). There is a direct transmembrane link between fibronectin and the cell interior and the integrins are the group of molecules which mediate this link. These adhesion sites contain the surface

receptor complex, linking intracellular cytoskeletal elements to extracellular fibronectin (Heggeness et al, 1978; Kleinman et al, 1981). It is via these complex transmembrane structures, that the extracellular matrix can exert influence on the cellular cytoskeleton and induce migration.

Fibronectin is thought to be crucial in many components of wound healing including reepithelialisation, cell migration, wound contraction and matrix deposition (McDonald, 1988). Depletion of fibronectin from plasma clots prevents fibroblast migration (Knox et al, 1986). Fibronectin and its cell adhesive fragments are chemotactic for dermal fibroblasts (Postlethwaite et al, 1981) and fibronectin fragments are also chemotactic for monocytes which play an important role in wound healing. Fibronectin is an important part of the early extracellular matrix at the wound site (Williams et al, 1984), and collagen gets deposited into a fibronectin rich environment (Clark et al, 1983). As dermal wounds age and the healing response subsides, detectable fibronectin decreases (Grinnell et al, 1981). However, if fibronectin is present in aqueous humour fibronectin would continue to be presented to the wound site.

In the ELISA assays, fibronectin was detected in the aqueous humour of both cataract controls and patients with primary open angle glaucoma. The mean level in cataract controls was  $1.31 \pm 0.10$  (SEM)  $\mu\text{g/ml}$  and  $1.92 \pm 0.24$  (SEM)  $\mu\text{g/ml}$  which is similar to the level found in bovine aqueous by Reid and colleagues of  $2.46 \mu\text{g/ml}$  (Reid et al, 1982), which is about 1/100 that found in plasma. Levels in human aqueous had not been measured before our study. Possible sites of synthesis include the trabecular meshwork (Polansky et al, 1984; Worthen and Cleveland, 1982), the corneal endothelium (Zetter et al, 1978), the ciliary body (Tervo et al, 1986; Kohno et al, 1987) and plasma if there is breakdown of the blood aqueous barrier. The reason for the higher concentration in glaucomatous aqueous is unknown. I was not able to assay protein levels at the same time as all the aqueous was used for the simultaneous migration and fibronectin assays. However, if the increase in fibronectin level was a reflection of a general increase in protein content of the aqueous, it would have been expected that the chemoattractant activity of the aqueous to be greater, which it was not.

Furthermore, there was no correlation between the levels of fibronectin and number of cells migrated in that aqueous sample. The addition of polyclonal antibody which would be expected to block many sites including those on the 140,000 MW non-gelatin binding fragment that appears to be chemotactic region for human dermal fibroblasts (Postlethwaite et al, 1981). The addition of 1/100 polyclonal antibody to fibronectin blocked 78% of the migration to a solution of fibronectin  $5 \mu\text{g/ml}$ , whereas

addition of the same concentration of antibody to aqueous only reduced migration by 16%. In conclusion, the results of the experiments on cataract and glaucomatous aqueous confirmed the chemoattractant activity of human aqueous humour, but did not show any increased activity in the primary aqueous from glaucoma eyes despite increased levels of fibronectin. Together with antibody neutralising experiments this strongly suggested that fibronectin was not the major component of the chemoattractant activity of aqueous humour.

These experiments required all the aqueous collected over a year. In view of small amounts of aqueous available, and the practical problems in collecting and assaying for each growth factor and the biological activity in aqueous, I then proceeded to assays of biological activity of certain growth factors known to be in aqueous humour to initially identify key growth factor(s). Epidermal growth factor (EGF), basic fibroblast growth factor (bFGF) and transforming growth factor  $\beta$ 1 (TGF- $\beta$ 1) were selected as they were available in their pure form through recombinant DNA technology and the amounts required for the necessary experimental design were obtainable and financially realistic at the time of our experiments. Previous *in vitro* and *in vivo* studies have shown that these growth factors have marked effects on general and anterior segment wound healing (Clark and Henson, 1988; Tervo et al, 1992) (reviews). The effects of these growth factors on human Tenon's capsule fibroblasts had not been previously investigated. Furthermore, simultaneous comparisons of these three aspects of biological behaviour in relation to the different growth factors had not been carried out before in the ocular or general scientific literature. We chose to assay proliferation, migration and collagen production as these are essential components of the healing process.

## **4.2 Stimulatory effects of growth factors found in aqueous humour**

### **4.21 EGF**

Epidermal growth factor (EGF) has been studied more extensively than any other peptide growth factor for effects on ocular anterior segment cells. EGF was first described by Cohen (Cohen, 1962) as a protein from the submaxillary glands of mice that induced premature eyelid opening and tooth eruption in neonatal mice, and because of the effect on epidermal tissues it was named epidermal growth factor. Inevitably a great deal of research has concentrated on corneal epithelial cell response because of the therapeutic potential of EGF.

EGF and proliferation There is evidence that EGF stimulates proliferation in ocular cells. EGF accelerated re-epithelialisation of corneal surface injuries in rabbits and primates *in vivo* (Brightwell et al, 1985; Petroustos et al, 1984; Ho et al, 1974; Daniele et al, 1979; Brazzell et al, 1991) and stimulated the proliferation of corneal epithelial cells *in vitro* (Watanabe et al, 1987; Kruse and Tseng, 1991). Epithelial cells respond to EGF by increasing DNA synthesis (Reddan and Wilson-Dziedzic, 1983). Kitazawa and colleagues (Kitazawa et al, 1990) reported that the acceleration of rabbit epithelial healing observed with topical EGF was associated with a two-fold increase in epithelial cell division. EGF stimulated DNA synthesis of rabbit stromal fibroblasts in culture (Woost et al, 1985) and also stimulated mitosis of rabbit, bovine, primate, and human corneal endothelial cells *in vitro* (Woost et al, 1992; Couch et al, 1987; Nayak et al, 1986; Nayak and Binder, 1984) and increased endothelial cell density in primates (Fabricant et al, 1981) following endothelial injury *in vivo*. EGF has also been shown to stimulate the proliferation of non-ocular epithelial cells, fibroblasts and endothelial cells (McAuslan et al, 1985; Stanulis-Praeger and Gilchrest, 1986; Nakagawa et al, 1985; Canalis and Raisz, 1979). Thus, EGF has been reported to enhance wound healing *in vivo* and to stimulate mitosis of ocular anterior segment cells *in vitro*.

My experiments showed that EGF resulted in only a small increase in thymidine uptake (1.77 compared to media only) at higher concentrations of EGF ranging from  $10^{-7}$  to  $10^{-10}$  Molar (580 - 0.58 ng/ml), suggesting that EGF is not a major stimulator of human Tenon's capsule fibroblast proliferation. This is similar to the concentration (10 ng/ml =  $1.72 \times 10^{-9}$  Molar) which stimulated rabbit corneal epithelial cells to increase their mitotic rate (Raymond et al, 1986).

EGF and migration The effects of EGF on ocular cell migration have been studied less thoroughly than its effects on ocular cell mitosis. Watanabe et al (Watanabe et al, 1987) reported that EGF and fibronectin each stimulated the migration of rabbit corneal epithelial cells along the edges of corneal blocks in organ culture. In a subsequent study, they reported that EGF did not stimulate the chemotaxis of cultured rabbit corneal epithelial cells using a modified Boyden chamber, whereas fibronectin stimulated chemotaxis and chemokinesis (Watanabe et al, 1988). Soong and colleagues also reported that EGF enhanced the epithelial wound closure rate of organ-cultured rat corneas, but concluded that the effect of EGF was due primarily to stimulation of proliferation rather than individual cell motility (Soong et al, 1989). This conclusion was based on their observations that EGF failed to stimulate the migration of rat and rabbit corneal epithelium using Boyden chambers and agarose drop studies



and that addition of colchicine, an antimetabolic agent, blocked the effect of EGF on organ-cultured corneas. Nickoloff and colleagues (Nickoloff et al, 1988) reported that EGF stimulated the migration of normal human epithelial cells (keratinocytes) in a modified Boyden chamber assay demonstrating that EGF was chemotactic for skin epithelial cells. Joyce and co-workers investigated the effects of EGF and/or indomethacin treatment on rabbit corneal endothelial wound closure in mitotically competent and 5-fluorouracil inhibited cultures (Joyce et al, 1989; Joyce et al, 1990). EGF appeared to stimulate migration, whereas indomethacin enhanced cell spreading.

The migration experiments with EGF and Tenon's capsule fibroblasts showed that EGF stimulated the migration of human Tenon's capsule fibroblasts at higher concentrations of EGF ( $10^{-7}$  to  $10^{-10}$  Molar = 580 - 0.58 ng/ml). The concentration of EGF used in all of the above mentioned experiments was 50 ng/ml ( $0.86 \times 10^{-8}$  Molar), within the range we found stimulated migration. The number of cells migrated was very significant in that it was 1.54 times greater than that achieved with 20% foetal calf serum and 8 times greater than that seen with media only. EGF stimulated more migration in absolute terms than either TGF- $\beta$ 1 or bFGF. This stimulation consisted of both chemotaxis and chemokinesis as assayed by the checkerboard technique, but the chemotactic effect was greater than the chemokinetic effect (123 versus 77 cells). These results suggest that EGF is a very potent chemoattractant for human Tenon's capsule fibroblasts.

EGF and collagen synthesis There is no specific data in the literature on EGF and the stimulation of collagen production in fibroblasts. However, EGF has been reported to increase tensile strength of corneal incisions in rabbits and primates (Brightwell et al, 1985; Woost et al, 1985; Mathers et al, 1989; Petroutsos et al, 1986). Experiments using wound chambers *in vivo* suggest a role for EGF in deep wound healing such as surgical wounds. EGF has been shown to stimulate fibroplasia and collagen deposition when used in a wound chamber model (Laato et al, 1986). A pellet of slow release EGF resulted in increased granulation tissue, a doubling of DNA content and a 33% increase in protein content and wet weight compared to controls (Buckley et al, 1985). However, EGF has also been shown to decrease collagen synthesis in bone, possibly due to a loss of the differentiated phenotype during cell proliferation (Canalis and Raisz, 1979), and EGF has also been shown to stimulate collagenase production (Chua et al, 1985).

The experimental results revealed that EGF could stimulate an increase in the collagen fraction after  $^3\text{H}$ -proline uptake. This increase only occurred at higher

concentrations ( $10^{-7}$  to  $10^{-9}$  Molar = 580 - 5.8 ng/ml) and was much smaller (0.33) than the increase induced by the positive control of 20% foetal calf serum. Nonetheless, the results revealed that EGF was capable of inducing an increase in extracellular matrix formation; this may partially account for some of the *in vivo* findings reported above.

#### 4.22 bFGF

In the eye, an important role for basic FGF has been documented in the processes of tissue repair, wound healing, and angiogenesis (Gospodarowicz et al, 1985; Tripathi et al, 1990). It is probable that bFGF is derived from the eye in that extracts of the iris choroid lens and vitreous body have a stimulatory effect on the epithelium of the bovine lens (Barritault et al, 1981). Normal analysis of mRNA from cell extracts of iris melanocytes corneal epithelium, and lens epithelium have demonstrated the presence of the transcripts of the bFGF gene (Schweigerer et al, 1988; Plouet and Gospodarowicz, 1990). Basic FGF stimulates a variety of ocular cells.

bFGF and proliferation The fibroblast growth factor family (FGF) enhance ocular healing, particularly corneal epithelial (Steinmann et al, 1990) and endothelial (Gospodarowicz et al, 1986) healing, and are highly angiogenic (Folkman and Klagsbrun, 1987). The mechanism by which FGF accelerates healing of corneal wounds *in vivo* has not been fully established. Most of the studies on FGF and the anterior segment of the eye have concentrated its mitogenic effect on corneal cells. FGF stimulated proliferation of bovine corneal epithelial cells (Gospodarowicz et al, 1977), human stromal fibroblasts (Woost et al, 1985), and bovine endothelial cells (Woost et al, 1992) in culture. FGF accelerated healing of rabbit epithelium following mild chemical injury (Petroutsos et al, 1984) or epithelial scrape injury (Petroutsos et al, 1984; Fredj et al, 1987) and increased regeneration of corneal endothelium in cats following transcorneal freeze injury (Landshman et al, 1987). FGF also stimulates the proliferation of other non-ocular cell types including fibroblasts, endothelial cells and a variety of cells of mesodermal origin. The addition of FGF results in stabilisation of phenotype, extension of culture lifespan, and shorter doubling times (Duthu and Smith, 1980; Gospodarowicz, 1979; Gospodarowicz and Bialecki, 1978; Simonian et al, 1979). FGF also has mitogenic effects on other cell types including adrenal cortex, granulosa cells, vascular smooth muscle cells, chondrocytes and mouse fibroblasts (Gospodarowicz et al, 1985; Davidson et al, 1985).

Not surprisingly, bFGF stimulated the proliferation of Human Tenon's capsule fibroblasts, significant differences from media alone occurring in the range  $10^{-8}$  to  $10^{-12}$  Molar = 130 - 0.013 ng/ml). The maximal response occurred at  $10^{-11}$  Molar (0.13 ng/ml) which was equal to 20% foetal calf serum and 3.4 times greater than media alone. Human trabecular meshwork cells are stimulated to mitose, with the addition of 1 ng/ml ( $0.77 \times 10^{-10}$  Molar). No additional increase in the rate of mitoses occurred with a 10 ng/ml ( $0.77 \times 10^{-11}$  Molar) concentration of basic FGF (Tripathi et al, 1990). Basic FGF also stimulates the proliferation *in vitro* of corneal endothelial cells and lens epithelial cells at concentrations as low as 5 pg/ml ( $0.39 \times 10^{-12}$  Molar) and 10 pg/ml ( $0.78 \times 10^{-12}$  Molar) respectively (Gospodarowicz et al, 1977; Gospodarowicz et al, 1985). Concentrations of 0.3 ng/ml ( $2.31 \times 10^{-11}$  Molar) induce profuse capillary formation in the rabbit cornea (Gospodarowicz et al, 1979).

bFGF and migration The effects of FGF on chemotaxis or chemokinesis of ocular cells had not been reported at the time of our study. FGF had been reported to stimulate migration of other cells *in vitro*. Terranova and colleagues (Terranova et al, 1985) demonstrated that FGF stimulated both chemotaxis and chemokinesis of human umbilical vein endothelial cells in modified Boyden chamber checkerboard assays. In our experiments the dose-response curve for FGF on the migration of reached a maximum at  $10^{-8}$  Molar concentration (130 ng/ml) tailing off at  $10^{-7}$  Molar (1300 ng/ml). This stimulation consisted of both chemotaxis and chemokinesis although chemotaxis was the primary component.

bFGF and collagen synthesis FGF mediates changes of collagen metabolism in endothelial cells and fibroblasts by stimulating the expression of collagenase. This increase activity of the enzyme is related to changes in collagenase RNA levels (Edwards et al, 1987; Buckley-Sturrock et al, 1989; Chua et al, 1985). FGF can stimulate the production of fibronectin and collagen types by vascular endothelial cells (Gospodarowicz, 1984). If polyvinyl sponges are implanted subcutaneously in rats, the addition of FGF results in an increase in the collagen content of the sponge compared to control (Davidson et al, 1985). However, it is of interest that Tan and colleagues found that bFGF reduced hydroxyproline uptake and RNA levels of collagen pro- $\alpha 1(I)$  type I collagen mRNA in fibroblasts grown from normal and hypertrophic scars in the range  $10^{-9}$  to  $10^{-11}$  Molar (Tan et al, 1993). We found a fall in  $^3\text{H}$  proline uptake at  $10^{-10}$  Molar relative to media (although this was not statistically significant), but  $^3\text{H}$  proline uptake was significantly greater than media alone in the range  $10^{-9}$  to  $10^{-7}$  Molar.

## 4.23 TGF- $\beta$

TGF- $\beta$  is a potent peptide growth factor family that acts as a bifunctional regulator of cell division: TGF- $\beta$  generally inhibits mitosis of ectodermally derived cells and stimulates mitosis of mesothelium derived cells (Sporn et al, 1986), at least *in vitro*.

TGF- $\beta$  and proliferation The effects of TGF- $\beta$  on ocular cells and ocular wound healing have not been extensively studied. *In vitro* experiments have shown that TGF- $\beta$  is a weak mitogen for bovine corneal endothelial cells in serum-free medium (Woost et al, 1992). TGF- $\beta$  is better known as a inhibitor, but it was identified on the basis of it's ability to act synergistically with EGF and stimulate proliferation on normal rat kidney fibroblasts in soft agar. Other fibroblast types are inhibited by TGF- $\beta$  in culture (Anzano et al, 1986). However, the interpretation of cell culture data is complicated by the concurrent use of serum, which is a good source of PDGF, TGF- $\beta$  and EGF. Although TGF- $\beta$  is known as an inhibitor of fibroblast proliferation, we found it significantly stimulated proliferation in a range of concentrations from  $10^{-10}$  to  $10^{-12}$  Molar. Furthermore, this was quite a significant stimulation 6.9 times greater than media only and also 1.75 times greater than 20% FCS/media.

TGF- $\beta$  and migration TGF- $\beta$  has also been reported to be a potent chemotactic factor for dermal fibroblasts (Postlethwaite et al, 1987) and monocytes (Wahl et al, 1987). TGF- $\beta$  stimulated chemotaxis of cultured human dermal fibroblasts, with a peak response at 12.5 pg/ml ( $0.5 \times 10^{-13}$  Molar) but did not stimulate significant chemokinesis (Postlethwaite et al, 1987). TGF- $\beta$  was also a potent stimulator of migration of peripheral human blood monocytes, producing a peak response at 0.1-1.0 pg/ml ( $0.4-4 \times 10^{-13}$  Molar) (Wahl et al, 1987).

TGF- $\beta$  stimulated the rate of epidermal regeneration of partial thickness injuries in pig skin (Jones et al, 1991). *In vitro* models of epithelial wound healing showed that TGF- $\beta$  increased the outgrowth of epithelial keratinocytes in organ-cultured explants of pig skin (Hebda, 1988). The ability of TGF- $\beta$  to initiate earlier outgrowth of epithelial cells was apparently not due to an effect on mitosis because TGF- $\beta$  did not increase incorporation of tritiated thymidine into keratinocytes in the growing epidermal sheets. Thus, the ability of TGF- $\beta$  to stimulate epidermal regeneration of partial thickness skin wounds *in vivo* is probably a result of TGF- $\beta$  stimulation of epithelial cell migration.

We found that the peak of migration occurred at similar concentrations to these studies ( $10^{-13}$  Molar = 2.5 pg/ml) but at much lower concentrations than the other growth factors. The peak migration occurred at a concentration of TGF- $\beta$ 1 which was approximately 1,000 times lower than the optimal concentrations for EGF, and 100,000 times lower than the optimal concentration for bFGF. The physiological significance of a peak in migration is unclear. However, a possibility includes TGF- $\beta$ 1 inducing fibroblasts cells to migrate at lower concentrations of TGF- $\beta$ 1, and then a cessation of migration at a position in a wound with the highest TGF- $\beta$ 1 concentration. The reduction of migration at higher concentrations of TGF- $\beta$ 1 may then be associated with a change in function of the fibroblast to a cell that is optimally stimulated to synthesise extra cellular matrix in the wounded area.

TGF- $\beta$  and collagen synthesis The effects of TGF- $\beta$  on extracellular matrix production by a variety of cells has been well studied *in vitro* and *in vivo*. TGF- $\beta$  activates gene transcription and increases synthesis and secretion of matrix proteins, decreases synthesis of proteolytic enzymes that degrade matrix protein and increases synthesis of proteins that block the activity of these degradative enzymes. TGF- $\beta$  also increases both transcription, translation and processing of cellular receptors for matrix proteins. The multiple levels in which TGF- $\beta$  acts suggests that the control of matrix interactions of cells represents one of the most important mechanisms by which the peptides control growth, differentiation and function of mesenchymal cells.

Many fibroblastic cell lines of human and other animal origins show increased synthesis of type I collagen and fibronectin following treatment with TGF- $\beta$  (Ignatz et al, 1987; Roberts et al, 1986; Wrana et al, 1986). TGF- $\beta$  stimulates the production of many other extracellular matrix proteins including type III, IV, V collagen (Madri et al, 1988; Rossi et al, 1988) thrombospondin (Penttinen et al, 1988) osteonectin (Noda et al, 1988) tenascin (Pearson et al, 1988) elastin (Liu and Davidson, 1988) and chondroitin and dermatan sulphate proteoglycans (Chen et al, 1987; Falanga et al, 1987; Morales and Roberts, 1988). TGF- $\beta$ 1 and 2 (the predominant form in the eye) are equipotent in the induction of matrix protein synthesis.

The concentrations of TGF- $\beta$  that we have shown to stimulate synthesis of collagen production in our fibroblast cultures are in the range  $10^{-10}$  to  $10^{-7}$  Molar (2.5 to 2500 ng/ml). Other studies have shown maximal stimulation of collagen synthesis in the somewhat lower concentration range of 5 to 50 X  $10^{-12}$  Molar (0.125 to 1.25 pg/ml) (Ignatz et al, 1987). However, there have not been other studies directly comparing the effects of the same TGF- $\beta$  material on migration and extracellular matrix

synthesis simultaneously.

#### **4.24 Summary of effects of growth factors**

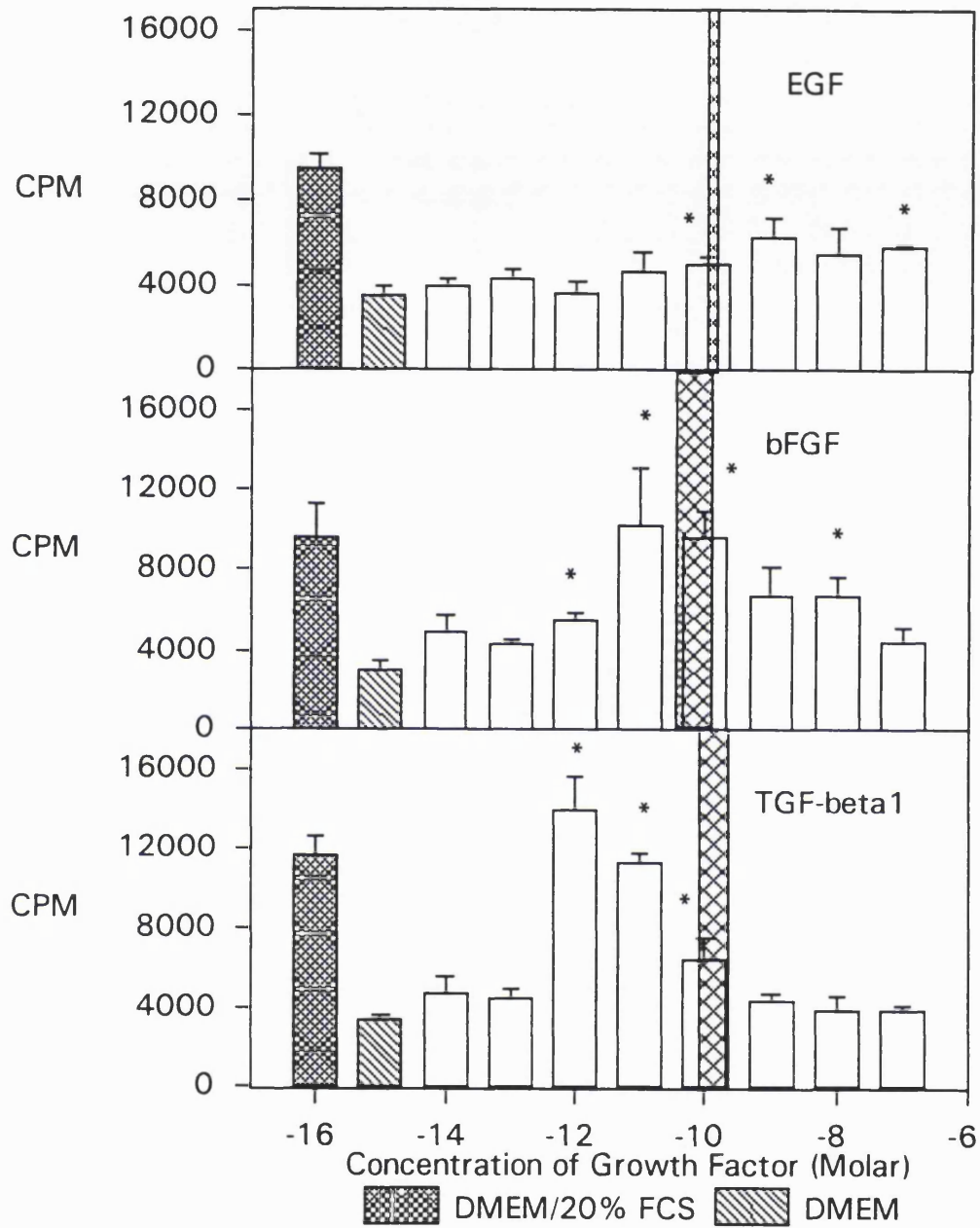
Although a number of studies have reported an enhancement of wound healing by EGF, FGF, and TGF- $\beta$ , the effects of peptide growth factors on proliferation, migration and collagen production of human Tenon's Capsule fibroblasts have not been previously investigated. The experimental results we have shown indicate that peptide growth factors can stimulate all of the components of wound healing that we tested, i.e. migration, proliferation, and synthesis of extracellular matrix.

#### **4.25 Significance of growth factor levels *in vitro* and *in vivo***

It is difficult to know the significance of the dose range responses and the actual levels of growth factors and aqueous tear levels. The levels of EGF, bFGF and TGF- $\beta$  found in aqueous humour have been superimposed onto the three graphs of proliferation, migration and collagen production for the three growth factors (**Figure 62, 63 and 64**). For EGF levels equivalent to those found in aqueous (Parelman and colleagues, 0.62-1.4 ng/ml =  $1.07-2.41 \times 10^{-10}$  Molar) (Parelman et al, 1990) do not particularly stimulate collagen production or proliferation, but run into the peak of migratory stimulation. Average levels in basal tears have been reported as 8466 pg/ml ( $1.46 \times 10^{-9}$  Molar) and stimulated tears as 2763 pg/ml ( $0.47 \times 10^{-9}$  Molar)(van Setten, 1990). For bFGF, the concentrations in aqueous reported by Tripathi et al (Tripathi et al, 1988; Tripathi et al, 1990) (700 to 1400 pg/ml ( $5.6-10.8 \times 10^{-11}$  Molar) resulted in stimulation of fibroblast proliferation, low levels of migration and low levels of collagen production. For transforming growth factor beta, "normal" aqueous levels (2.3-8.1 ng/ml =  $0.9-3.2 \times 10^{-10}$  Molar)(Jampel et al, 1990) stimulated some degree of proliferation, a minimal amount of migration, but a moderate amount of collagen production.

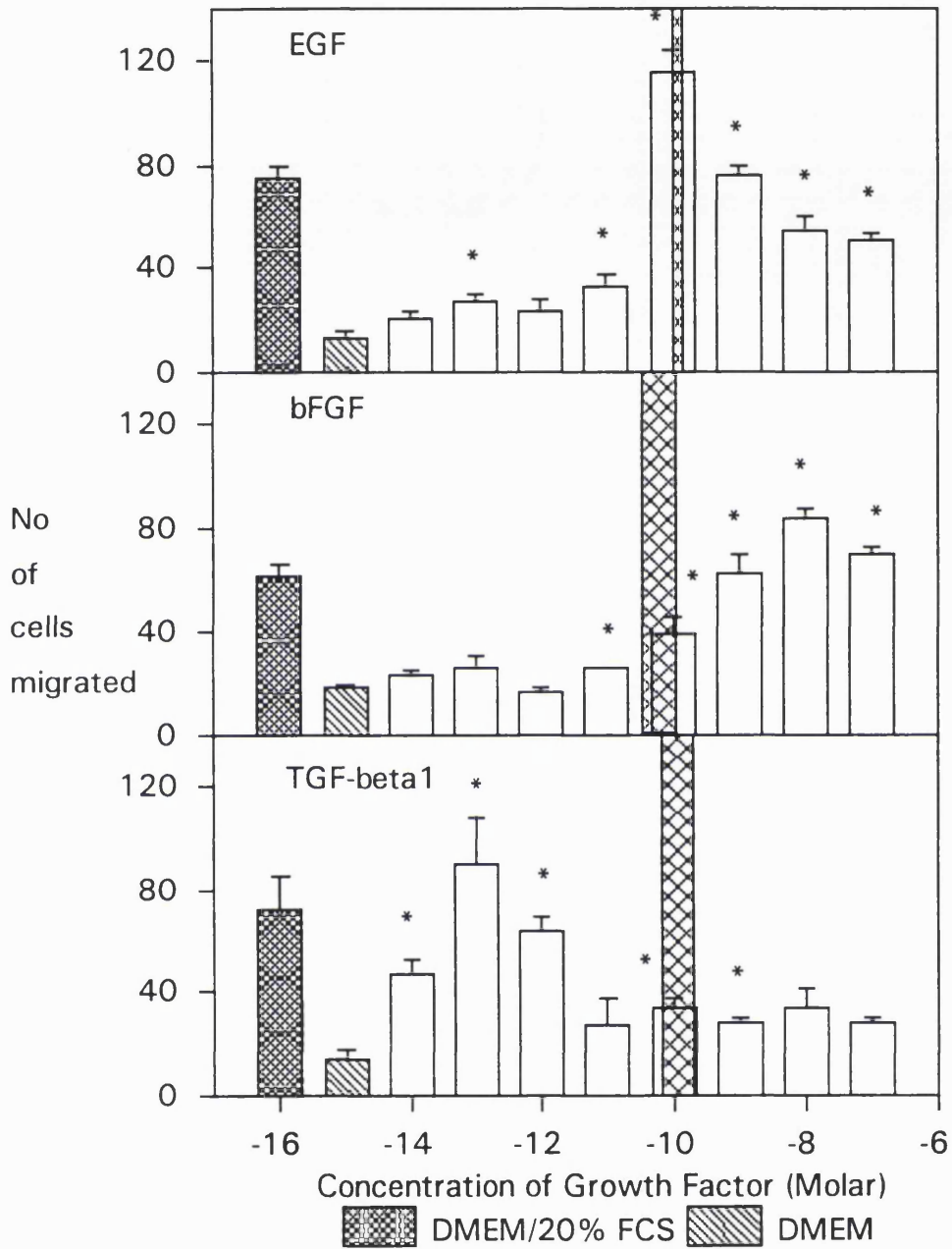
However, other circumstances within the *in vivo* environment may contribute to variations in responses to growth factors. The matrix is also important as within their extracellular matrix, dermal fibroblasts limit their proliferative activity to that required to maintain their steady state number (Sarber et al, 1981). bFGF binds to heparan

**Figure 62** Human Tenon's capsule fibroblast proliferative response to different concentrations of EGF, bFGF and TGF- $\beta$ 1 in relation to concentrations found in primary human aqueous humour.



The concentrations of EGF (Parelman et al 1990), bFGF (Tripathi et al 1988, 1990) and TGF- $\beta$  (Jampel et al 1990) found in aqueous humour have been represented as a vertical bar with a diagonal criss/cross pattern.

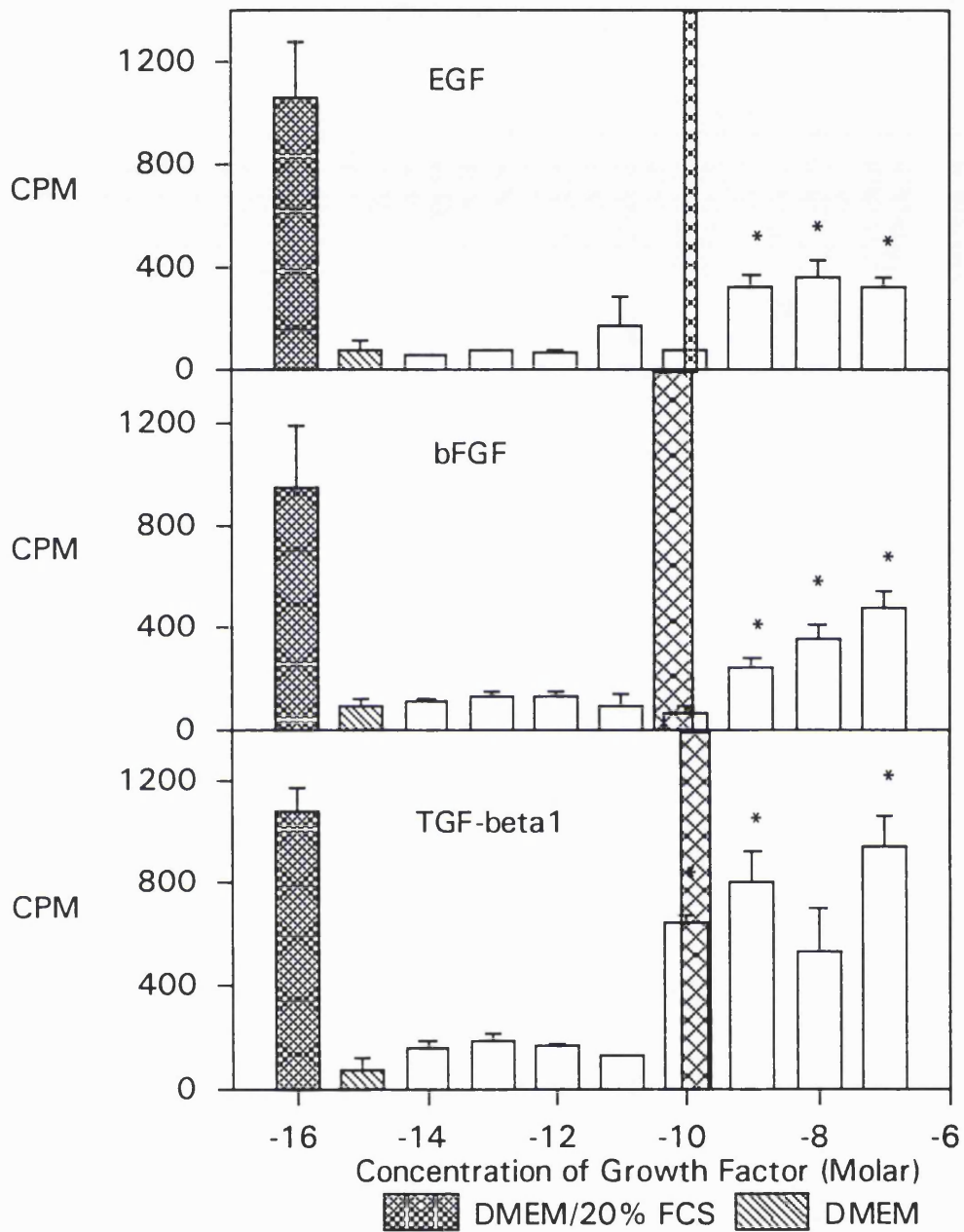
**Figure 63** Human Tenon's capsule fibroblast migratory response to different concentrations of EGF, bFGF and TGF- $\beta$ 1 in relation to concentrations found in primary human aqueous humour.



The concentrations of EGF (Parelman et al 1990), bFGF (Tripathi et al 1988, 1990) and TGF- $\beta$  (Jampel et al 1990) found in aqueous humour have been represented as a vertical bar with a diagonal criss/cross pattern.



**Figure 64** Human Tenon's capsule fibroblast collagen production response to different concentrations of EGF, bFGF and TGF- $\beta$ 1 in relation to concentrations found in primary human aqueous humour.



The concentrations of EGF (Parelman et al 1990), bFGF (Tripathi et al 1988, 1990) and TGF- $\beta$  (Jampel et al 1990) found in aqueous humour have been represented as a vertical bar with a diagonal criss/cross pattern.

sulphate in the extracellular matrix (Bashkin et al, 1989) and basement membranes (Folkman et al, 1988). It has been suggested that cell surface glycosaminoglycans such as heparan sulphate proteoglycan bind bFGF, and present growth factor to the high affinity FGF receptors on the cells (Yayon et al, 1991). Folkman has postulated that the great affinity of bFGF for the extra cellular matrix molecule heparin limits it's availability to adjacent cells (Folkman et al, 1988). The state of growth factor activation is also important. In our experiments all the TGF- $\beta$ 1 was activated by acid exposure prior to use. In normal aqueous about 60% is in the active form, but this would expected to increase in conditions associated with wound healing such as an acidic pH (Silver et al, 1988) and increased protease activity (Lyons et al, 1988).

Furthermore, under normal circumstances, in most of the aqueous flow is via Schlemm's canal and then venous drainage the majority of the growth factor will not come into direct contact with human Tenon's capsule fibroblast. However, after glaucoma filtration surgery where there is continuous aqueous contact with the conjunctiva and sub-conjunctiva tissues. If one assumes that the levels of these three growth factors return close to the concentrations seen in pre-operative cataract patients then it would seem that the aqueous humour should be broadly stimulatory. In the laboratory it certainly is stimulatory for migration, and despite opinions to the contrary (Herschler, 1981) aqueous humour seems to stimulate some proliferation *in vitro* (Albrink and Wallace, 1951; Burke et al, 1982; Radius et al, 1980; Kwong et al, 1984). However, given that many cases of filtration surgery succeed, there are many other factors involved.

An aspect of conjunctival wound healing that remains undetermined is whether gradients of peptide growth factors are generated at the site of an injury. In the case of epithelial and conjunctival stromal injuries, growth factors such as EGF, which have been detected in tears, (Ohashi et al, 1989; van Setten et al, 1989; van Setten, 1990) could establish a concentration gradient by diffusion into tissues from the edge of the injury. Gradients could also be established by the presence of aqueous flow through the wound.

An important factor may be the breakdown of the blood aqueous barrier that occurs after the surgery or paracentesis. In this situation, one would expect the levels of growth factors to be higher than found in intraoperative cataract patients. This will result in considerably higher concentrations of growth factors, which in balance would probably be more stimulatory, particularly for collagen production with higher concentrations of transforming growth factor  $\beta$ -1. In some circumstances this blood aqueous barrier breakdown may persist resulting in a chronically elevated level of

growth factors in the wound area. In these circumstances, the experimental results suggest that there would be persistent stimulus for collagen production. This is particularly important as ultimately it is the new extra cellular matrix formation that is responsible for the blockage of flow of aqueous through the bleb area.

#### 4.26 Interaction of growth factors

It is difficult to be sure of the exact role of the different relative concentrations *in vivo*, particularly because of the complex interaction of growth factors and other components of the aqueous. For instance, EGF antagonises the effects of TGF- $\beta$  on collagen formation *in vivo* (Roberts et al, 1986). TGF- $\beta$  interferes with the action of many different mitogens including PDGF and EGF (Roberts et al, 1985a; Anzano et al, 1986), FGF (Baird and Durkin, 1986) and IGF-1 (Hill et al, 1986). Furthermore, it is not easy to extrapolate to an *in vivo* situation as TGF- $\beta$  is a multifunctional growth factor (Sporn and Roberts, 1988). The nature of its action on the target cell is dependent on many parameters including the cell type and state of differentiation, the growth conditions including the extracellular matrix and other growth factors present (Sporn et al, 1987). TGF- $\beta$ 1 stimulates the growth of NRK cells in the presence of EGF, but actually inhibits the growth and antagonises the mitogenic reaction of EGF on the same cells in monolayer (Roberts et al, 1985a). In Fischer rat 3T3 cells transfected with the oncogene *myc*, TGF- $\beta$ 1 can either stimulate or inhibit the growth of cells depending on whether EGF or PDGF are also present in the assay (Roberts et al, 1985a). TGF- $\beta$ 1 stimulates the growth of fibroblasts from very early human foetuses, but inhibits the growth of fibroblasts derived from foetuses of late gestational age (Hill et al, 1986).

The growth factors may also act synergistically stimulating or inhibiting cell functions. EGF acts *in vivo* with other growth factors such as TGF- $\beta$  (Assoian et al, 1984) PDGF (Assoian et al, 1984; Shimokado et al, 1985) and bFGF (Esch et al, 1985). Efficient proliferation of rat kidney fibroblasts soft agar is stimulated by the concerted action of TGF- $\beta$ , PDGF and EGF (Assoian et al, 1984). Horton et al have shown that bFGF is capable of acting synergistically with TGF- $\beta$  to inhibit type II collagen expression by chick chondrocytes (Horton et al, 1989).

It is of interest that the peaks of migration and proliferation for all the growth factors tested occurred at concentrations lower than the highest tested in the experiments ( $10^{-7}$  Molar). In contrast, the collagen production had not peaked at the highest concentration tested for all the other growth factors. Despite the previously discussed limitations of the *in vivo* study, it is interesting to speculate whether

fibroblasts are stimulated to proliferate and migrate in areas peripheral to the wounded area. Once they have reached the area of very high concentration (which would be expected to be the central area of wounding) the maximum stimulus then is not to proliferate but to reduce migratory and proliferative behaviour and to increase collagen production.

Although the presence of a mixture of factors and the *in vitro* environment may modulate the individual effects of the growth factors, the experiments do identify that all the growth factors testing are capable of stimulating Tenon's capsule fibroblast proliferation, migration and collagen production. Albeit there is a variation in the magnitude of response and dose response curve for each growth factor. These studies further support the concept that some stimulatory factors, particularly peptide growth factors probably play important physiological roles in modulating the cellular response of the conjunctiva to wounding, and that specific growth factors may elicit a greater absolute response than others.

#### **4.3 Effects of antiproliferative agents on ocular fibroblasts *in vitro***

The next step of this thesis was to investigate the effects of modulating agents on components of fibroblast behaviour. The fibroblast function I initially chose was proliferation as this was the fibroblast function most extensively tested in previous literature. Proliferation is a major component of the healing process after experimental filtration surgery (Jampel et al, 1988; Miller et al, 1990) and inhibition of this function appears to inhibit the healing process after glaucoma filtration surgery in humans (The Fluorouracil Filtering Surgery Study Group, 1989). Sodium butyrate was identified for study as pilot studies from the host laboratory had suggested it may be a useful agent for preventing intraocular scarring (proliferative vitreoretinopathy) in the rabbit (Savage et al, 1989). Sodium butyrate is a naturally occurring 4 carbon fatty acid salt which reversibly inhibits proliferation in certain mammalian cells in culture (Ginburg et al, 1973; Wright, 1973; Prasad and Sinha, 1976; Kruh, 1982), but these effects are reversible. Sodium butyrate has effects on the cell cycle (cells are arrested in G1) and affects the cytoskeleton, protein synthesis and cellular morphology (Ginburg et al, 1973; Wright, 1973; Prasad and Sinha, 1976; Kruh, 1982). It also acts as a differentiating agent on a variety of tumour cells (Riggs et al, 1977; Tsao et al, 1982; Viores et al, 1982; Kyritsis et al, 1984). It exerts its action by modifying gene expression (Leibovitch et al, 1982) by affecting histones, the basic proteins that interact with DNA (Boffa et al, 1978; Chahal et al, 1980) which may result in

conformational changes in DNA. Simultaneous experiments with 5-fluorouracil were carried out as this was the "gold standard" treatment in glaucoma filtration surgery, and there was extensive literature on its effects on fibroblast proliferation for comparison.

#### **4.31 Growth arrest after exposures to antiproliferative agents**

Both sodium butyrate and 5-fluorouracil inhibited proliferation as expected. The sodium butyrate treated cells rapidly recovered except when they were treated with the highest concentration (11,000  $\mu\text{g}/\text{ml}$ ) for the maximal period (12 days) when all the cells died. This recovery of proliferation was reflected in the increase in BrDU uptake after removal of sodium butyrate from the medium. With lower concentrations of 5-fluorouracil there was some recovery of proliferation at lower concentrations. However, the most interesting finding was the prolonged effect on proliferation of short term exposure to 5-fluorouracil, up to and including the 30 day limit of the experiments. Treatment for only one day at concentrations of 100 or 1000  $\mu\text{g}/\text{ml}$  caused marked inhibition of proliferation for at least 30 days. Treatment at a 5-fluorouracil concentration of 1  $\mu\text{g}/\text{ml}$  for 12 days had a similar effect in arresting growth in the cells for at least 30 days. This was true growth arrest as the cells were in media with full serum stimulation. The static cell number was not due to concurrent proliferation and cell death maintaining a steady cell number as the cells could be monitored because of the counting technique we used, and there was no increase in floating dead cells. Also, the percentage of BrDU positive cells did not rise following removal of 5-fluorouracil from the media confirming non-proliferating cells, and the percentage of trypan blue positive cells did not rise except at concentrations which were clearly associated with visible cell death.

#### **4.32 Previous data on growth arrest**

The long term effects of short exposures to 5-fluorouracil had not been extensively studied despite the large amount of literature on this drug. Using an MTT colour absorbance assay, Senderoff and colleagues exposed Chinese hamster ovary cells to 5-fluorouracil for 3 days, and then washed the cells and fed them with media and serum to assess recovery (Senderoff et al, 1990). Recovery began to occur 72 hours after cessation of treatment. However, although no actual drug concentration was given, the concentrations used appear to be between 0.1 and 1  $\mu\text{g}/\text{ml}$ . Yamamoto and

colleagues had examined the effects of 5-fluorouracil on rabbit subconjunctival fibroblasts using three concentrations (0.33, 1 and 3.3  $\mu\text{g/ml}$ ) of 5-fluorouracil for treatment periods of 2, 4, 7 and 15 days (Yamamoto et al, 1990). The fibroblasts were then counted at day 15. Exposure of the cells to the highest concentration of 3.3  $\mu\text{g/ml}$  for a 2 day period resulted in only an 8% increase in cell number at day 15. However, higher concentrations of 5-fluorouracil were not used and as such no gradual cell death was observed over the course of 30 days as observed in our study. It is of interest that the concentrations that inhibited proliferation had a differential effect on other cellular functions. Migration of the fibroblasts suspended in an agarose drop was not inhibited at these same concentrations; neither was the actin fibre distribution.

Based on the results from my first series of experiments, it seemed possible that even higher concentrations of 5-fluorouracil or other antiproliferative therapies for a much shorter period would have the same effect as the lower concentrations for a longer period. There was some clinical evidence even at the time of these experiments to support the concept that short exposures to the appropriate dose of an antiproliferative agent may have a prolonged effect on fibroblast proliferation. Beta radiation delivered to the filtration site immediately after filtering surgery in children with congenital glaucoma had considerably increased the success rate in these patients with a very high risk of failure (Miller and Rice, 1991). Chen had described that short five minute exposures to mitomycin-c at the filtering site had profound effects on the appearance and long term survival of filtering blebs in high risk patients, similar to the effects seen with 5-fluorouracil (Chen, 1983). However, this had been met with some scepticism as the concept based on the use of 5-fluorouracil injections at the time required continuous exposure to the agent, and there was no understanding as to how a single exposure to an agent could work.

Furthermore an extrapolation of our results suggested that increasing the available concentration would increase the long term effects on fibroblasts. Again there was clinical evidence that this might be the case. If the clinical injections of 5-fluorouracil were given into the bleb site, the concentration achieved would be much higher than that achieved by an injection 180° away. This is supported by previous pharmacokinetic studies by Kondo and Araie which showed concentrations at the site of injection 36 times higher than the conjunctiva 180° away (Kondo and Araie, 1988). Our pharmacokinetic experiments with butyrate showed concentrations 15 times higher in the injection area than 180° away. Therefore, few injections should be needed to produce significant inhibition of fibroblast proliferation at the filtering site. Loftfield and Ball's clinical report at the time of these experiments supported this hypothesis

(Loftfield and Ball, 1991). They gave an average of only 1.9 injections (compared to the 21 injections given routinely 180° away) directly into the bleb site both at the time of surgery and subsequently. Despite this small number of injections, the 5-fluorouracil treated group had a lower intraocular pressure (11.9 mmHg vs 14 mmHg), but not surprisingly, also had a significantly increased number of complications relating to the bleb site including wound leaks (9/23 vs 3/20) and maculopathy related to hypotony (4/23 vs 0/20).

#### **4.33 Long term effects after very short term exposures to antiproliferative agents**

Based on this literature and our experimental observations, the subsequent experiments exposing cells to very short duration therapies with radiation and selected antiproliferative agents were performed. The results demonstrated that very short (minutes) exposures to radiation or antiproliferative drugs at high concentration had long term effects on the proliferation and morphology of human Tenon's capsule fibroblasts. Our data showed that moderate doses of  $\beta$ -radiation (100-200 cGy) or 5 minute exposures to high dose 5-fluorouracil, 5-fluorouridine or mitomycin-c could result in a greater than 50% inhibition of proliferation relative to the control cells up to 36 days, again with minimal cell death as measured by trypan blue uptake and a continuous reduction in  $^3\text{H}$ -thymidine uptake.

Mitomycin-c at a concentration of 100  $\mu\text{g}/\text{ml}$  restricted an increase in cell number to 2.5 times the starting number of cells over the 36 day period in the tissue culture model. However, at a concentration of 1000  $\mu\text{g}/\text{ml}$  most of the cells died. At day 7 for the cells treated with 3000 cGy of  $\beta$ -radiation there was a fall in the total number of cells, and this occurred at day 14 in the cells treated with 1500 and 3000 cGy. Only 5-fluorouracil, even at the highest concentration was not able to induce cell death of the fibroblast population.

#### **4.34 Mechanism of growth arrest**

Why were these treatments having such a long term effect on cellular proliferation after such a short dose? It was easier to understand with radiation how this could occur. The effects of radiation are mediated by direct and indirect effects on the cell. Direct damage involves the atoms of the target itself such as DNA being ionised, and this occurs with high energy particles such as neutrons. Lower energy particles

associated with  $\beta$ -radiation interact with other atoms or molecules in the cell (particularly water) to produce free radicals that are able to diffuse far enough to reach and damage critical targets including DNA (Hall, 1988). The nucleus is probably the most important site of damage. A dose of 25,000 cGy delivered to the cytoplasm has no effect on proliferation, whereas a dose 1/20 th of this to the nucleus stops proliferation (Munro, 1970).

With soluble drugs this is more difficult. Assuming that most of the free drug in the cell culture well is being washed away by the irrigation regimen which dilutes the original drug at least 100,000 times, the drug must either be acting during the 5 minute exposure or must be being taken up by the cell and extracellular matrix and being metabolised over the subsequent hours and days. A combination of the two may be occurring. In one tumour cell line, it has been shown that the maximal accumulation of free intracellular 5-fluorouracil occurs within 200 seconds (Wohlhueter et al, 1980), so intracellular accumulation is probably occurring rapidly. Most cytotoxic base and nucleoside analogues and their physiological counter parts are transported into the cell more rapidly than they are metabolised (Heichal et al, 1978; Bowen et al, 1979; Rozengurt et al, 1977; Plagemann et al, 1978; Marz et al, 1979; Wohlhueter et al, 1980), particularly when there are high extracellular levels. In Ehrlich Ascites tumour cells there is rapid accumulation of radiolabelled metabolites of 5-fluorouracil such as  $^3\text{H}$ -FDdURD,  $^3\text{H}$ -FUra, and  $^3\text{H}$ -FdUMP. The nucleoside achieves near equilibrium within 15 seconds, and over the next 85 seconds the bulk of the  $^3\text{H}$  accumulates within the cell represents the phosphorylated derivatives (Bowen et al, 1979). 5-fluorouracil and these metabolites inhibit thymidylate synthetase which is required to convert ribonucleotides to deoxyribonucleotides for the synthesis of DNA in replicating cells. This inhibition is reversible and it would be expected that the cell population would recover when 5-fluorouracil was removed.

However, 5-fluorouracil is also incorporated into RNA, particularly at high concentrations (Evans et al, 1980; Cohen et al, 1958; Danneberg et al, 1958; Heidelberger, 1955). 5-fluorouridine also interferes with RNA synthesis and maturation, and high concentrations of 5-fluorouracil may interfere with the incorporation of uracil into RNA (Danneberg et al, 1958; Goldberg et al, 1966), and 5-fluorouracil may also be incorporated into RNA to give an aberrant form of one or more classes of RNA (Champe and Benzer, 1962; Kessel, 1980; Wilkinson et al, 1975). This incorporation may have subsequent effects on RNA processing and function, which may account for longer term non reversible effects of these drugs on the fibroblast (Maybaum et al, 1980). There is evidence to suggest that RNA incorporation will



probably be favoured by high concentrations of 5-fluorouracil and longer durations of exposure, and would be enhanced by the presence of thymidine, whereas the opposite conditions would favour thymidylate depletion (Spiegelmann et al, 1980; Santelli and Valeriot, 1978; Carrico and Glazer, 1979a). Incorporation of 5-fluorouracil into RNA has profound consequences for the processing and function of RNA (Wilkinson et al, 1975; Chaudhuri et al, 1958; Harbers et al, 1958). Under conditions of exposure to high concentrations of 5-FU, a maximum of 2% of uracil in RNA would be replaced by 5-fluorouracil (Evans et al, 1980).

Incorporation of 5-fluorouracil into RNA inhibits the processing of nuclear RNA to lower molecular weight to ribosomal RNA (The transition from 45s to 28s and 18s units) (Wilkinson et al, 1975). Polyadenylation of RNA, a process thought to confer stability on messenger RNA species, is also inhibited at relatively low concentrations of 5-FU (Carrico and Glazer, 1979b), whereas methylation of RNA bases is blocked at high concentrations of the drug (Tseng et al, 1978). 5-fluorouracil does cause errors in base pairing during transcription of DNA by RNA polymerase in isolated rat nuclei (Glazer and Legraverend, 1980). However, an examination of proteins produced in the cell free system by Poly A-RNA containing 5-fluorouracil failed to reveal a qualitative difference in the electrophoretic profile, although the overall rate of protein synthesis was stimulated as compared with the rate of synthesis using control RNA (Carrico and Glazer, 1979b).

Like 5-FU, mitomycin-c would be expected to be taken up rapidly by the cell. The mechanism of action of mitomycin-c is not well defined, but cytotoxicity results from the activation to a reactive species that alkylates and possibly cross-links DNA (Iyer and Szybalski, 1963). The actual site(s) of attachment of mitomycin-c to DNA have not been identified. Other mechanisms may also be working, and it is proposed that a free radical intermediate may be formed. The evidence for this comes in the form of evidence from electron spin resin studies, which have confirmed the presence of a free radical form of the drug *in vitro*, and also the fact that mitomycin-c may generate superoxide and hydroxide radicals in solution (Moore, 1977). The ultimate effects of mitomycin-c on DNA are alkylation, and single strand scission. The induction of single strand breaks may occur either through induction of free radical intermediates such as superoxide or hydroxyl radicals, which produce breaks in the phosphodiester backbone of DNA (Lown and Begleiter, 1976), or through attempts to repair alkylated sites on DNA. Strand breakage induced by reduced mitomycin-c can be prevented by free radical scavenger such as mannitol as well as by protective enzymes such as superoxide dismutase or catalase. The drug produces chromosome breaks in the

appearance of short fragments of DNA (Makino and Ocada, 1974). These actions would be expected to occur relatively rapidly after uptake, so this may explain the very prolonged effects on proliferation despite the short exposure.

#### **4.35 *In vitro* in relation to *in vivo* effects of antiproliferative agents**

However, experiments using tissue culture obviously have limitations. These experiments were performed on a monolayer of proliferating Tenon's fibroblasts which may be more sensitive to treatment than non-proliferating cells in Tenon's capsule in the eye. In the clinical situation the treatments are given intraoperatively when the majority of fibroblasts are not actively proliferating and the treatments would be expected to have less effect on the cells (Grillo and Potsaid, 1961).

There are limitations in applying the results of *in vitro* studies to the *in vivo* situation. In cell culture the cells are monolayers with a relatively small amounts of extracellular matrix, whereas in the *in vivo* situation they are surrounded by connective tissue which may impede drug penetration. It is relatively easy to deliver a standard concentration to a monolayer of cells. In addition, most of the cells in culture are proliferating, whereas most of the cells in the conjunctiva at the time of surgery are not. In theory, this would also make the cells of the conjunctiva less susceptible to the drug treatment. Therefore we proceeded to an experimental model to test whether these single arresting applications would work *in vivo*. The pharmacokinetic results with sodium butyrate injections which showed that injections resulted in a prolonged presence of drug for several hours. Therefore to reproduce the short single application of drug with exposure of the cells to a high concentration for a short period the delivery technique had to be changed. Furthermore, it was also incidentally thought to be far more convenient to deliver the drug over a five minute period focally than as an injection. The drug was therefore delivered using a sponge soaked in the various drugs in contact with the filtration area for five minutes followed by a saline washout.

#### **4.4 Effects of short single applications of antiproliferative agents *in vivo* (experimental filtration surgery)**

##### **4.41 Duration of effect**

The *in vivo* experiments showed that 5-minute intraoperative treatments with 5-fluorouracil 50 mg/ml or mitomycin-c at concentrations of 0.2 or 0.4 mg/ml

significantly prolonged the survival of filtering surgery in the rabbit as defined by flattening of the drainage bleb and return of the intraocular pressure to normal levels. Bleb survival was prolonged in the order mitomycin-c 0.4 mg/ml > mitomycin-c 0.2 mg/ml > 5-fluorouracil 50 mg/ml. Although it significantly prolonged bleb survival, the effect of intraoperative 5-fluorouracil appeared to be more transient than mitomycin-c 0.2 or 0.4 mg/ml.

The previous tissue culture results showed that the proliferation of Tenon's capsule fibroblasts could be inhibited relative to untreated fibroblasts for 36 days after a five minute exposure to 5-fluorouracil 25 mg/ml and mitomycin-c 0.1 mg/ml, but that the inhibitory effect of mitomycin-c 0.1 mg/ml was more pronounced than 5-fluorouracil 25 mg/ml. At a concentration of 1 mg/ml of mitomycin-c most of the fibroblasts died. The results of the present experiments appeared to support the cell culture finding that at a high concentration of 5-fluorouracil, inhibition of fibroblast proliferation occurs for a limited time after which the cells re-proliferate, compared to the higher dose of mitomycin-c which may be having a more prolonged and possibly more permanent effect on the local fibroblast proliferation and survival. The failure of 4 blebs at 30 days in the eyes treated with mitomycin-c 0.2 mg/ml suggests a dose response, possibly due to the recovery of some fibroblasts at this lower concentration. It is of interest that a single 5 minute exposure to 50 mg/ml of 5-fluorouracil had a similar length of effect on filtration surgery in the rabbit as that reported in a previous study in which 5-fluorouracil (1.5mg) was incorporated into a biodegradable polymer (Lee et al, 1988) with sustained release for a longer period. This suggests that the concept of peak concentration achieved can be as important as duration of exposure.

The results of these experiments confirmed a concentration dependency suggested by the cell culture studies, with regards to length of effect on the success on an *in vivo* model of filtration surgery. The success rate with mitomycin-c 0.4 mg/ml was greater than that of mitomycin-c 0.2 mg/ml and 5-fluorouracil 50 mg/ml. The rabbit is an aggressive model of scarring after filtering surgery, virtually all operations failing within 14 days (Miller et al, 1989; Miller et al, 1990; Lee et al, 1988; Bergstrom et al, 1991) without adjunctive treatment. It is probably at least equivalent to a "worst case scenario" in man. Any prolongation of filtering surgery in this animal model is probably reflected in an increased success rate in man, as in the case of previous studies with steroids (Miller et al, 1990), anti-crosslinking agents (McGuigan et al, 1986),  $\beta$ -radiation (Miller et al, 1990) and mitomycin-c (Bergstrom et al, 1991). As such our *in vivo* experiment suggested that it would be likely that 5 minute intraoperative exposures to 5-fluorouracil would be associated with an increased success rate after

filtration surgery in man.

However, although the experiments showed that these single applications did delay healing, it was important to establish the duration of cellular effects *in vivo*, and how focal this effect was. As such, the second set of experiments was designed to elucidate these points. The second series of experiments showed that 5 minute intraoperative exposures to 5-fluorouracil 50 mg/ml or mitomycin-c 0.4 mg/ml had a prolonged effect on the local subconjunctival and scleral fibroblast population. The effect of 5-fluorouracil was only temporary and delayed the fibroblast outgrowth from the explants for just over a week, when compared with the fibroblast outgrowths from tissues treated with distilled water treated area. After the fibroblast outgrowths recovered they had a normal growth rate and appearance. By way of contrast, the outgrowths from the mitomycin-c treated tissues had a significantly slower growth rate compared to the distilled water treated tissues, even in the tissues taken 30 days after surgery. The cells that did grow out were consistently abnormal in appearance with larger surface areas, multiple nuclei, and vacuoles suggesting that they had been permanently affected in the long term by the 5 minute mitomycin-c treatment even after *in vivo* treatment.

The previous *in vivo* cell culture experiments showed that human Tenon's capsule fibroblasts exposed for only a few minutes to a variety of antiproliferative treatments including beta-radiation, 5-fluorouracil, 5-fluorouridine and mitomycin-c could be inhibited for periods of up to 36 days, and that these effects were dose dependent. However, with a 5 minute exposure to a 5-fluorouracil concentration of 25 mg/ml there was recovery of cell proliferation, compared to a concentration of mitomycin-c of 0.1 mg/ml where there was minimal recovery. The results from this set of experiments supported my earlier findings. The long term effects appeared less marked in tissue samples taken after experimental filtering surgery, than the previous tissue culture findings would suggest. However, drug delivery and penetration in a cell monolayer would be expected to be greater with a more marked effect, than that delivered by a sponge through tissue.

#### **4.42 Localisation of effect**

These results also showed that the effects of 5 minute intraoperative drugs on tissue fibroblasts were localised to the area treated, as the fibroblast outgrowths from the adjacent tissues 90 and 180 degrees from the treated area, and the adjacent cornea were normal in appearance and outgrowth rate. In fact, because of the size of

the Weck Cell sponge, the edge of the treated area was only about 2-3 mm from the tissue taken 90 degrees from the centre of the treated area. The results suggested that large scale cellular repopulation of the biopsied site was not occurring, at least for the mitomycin-c treated tissue. Very small biopsies of normal rabbit ocular tissue usually give rise to a large area of normal fibroblast outgrowth, which did not occur with the mitomycin-c treated tissues. Measuring outgrowth from tissue explants assesses both cellular proliferation and motility, but previous experimental work suggests that proliferation is affected before cellular motility is affected after exposures to 5-fluorouracil and mitomycin-c (Yamamoto et al, 1990). The finding of a prolonged localised effect on tissue fibroblasts is an important concept in relation to the clinical situation.

#### **4.43 Relevance to different healing profiles: new model**

First, it may be possible to perform simultaneous surgery in adjacent areas (e.g cataract extraction through a corneal section or penetrating keratoplasty) at the same time as using intraoperative antiproliferatives with filtration surgery, without compromising the adjacent fibroblasts. Secondly, we may be able to vary the area of conjunctiva treated. There is experimental (Minckler et al, 1987) and clinical (Heuer et al, 1991) evidence that varying the size of a drainage plate (but only up to a certain surface area (Wilson et al, 1992) may result in a lower intraocular pressure. If the area treated with antiproliferative is varied, it may be possible to vary the final intraocular pressure. Paradoxically, the use of a lower concentration given over a wider field may possibly reduce the incidence of thin blebs whilst resulting in a similar fall in intraocular pressure. Thirdly, it may be possible to position the thin conjunctival bleb seen with intraoperative use of stronger agents such as mitomycin-c (Skuta et al, 1992) away from the limbus by exposing an area more posteriorly, sparing the limbal area, such as in the case of a Molteno tube plate. Thus, it may be possible to use a fornix based flap if the limbal conjunctival and scleral edge are spared from contact with the antiproliferative agent. At the same time our findings suggest that it would be prudent to use an intraoperative delivery technique that avoids exposing the wound edge to the drug.

The different lengths of effect on tissue fibroblasts after intraoperative exposures to 5-fluorouracil 50 mg/ml or mitomycin-c 0.4 mg/ml may determine their use clinically. Use of intraoperative exposures to 5-fluorouracil and mitomycin-c at these concentrations in the rabbit model of filtration surgery support and temporary effect

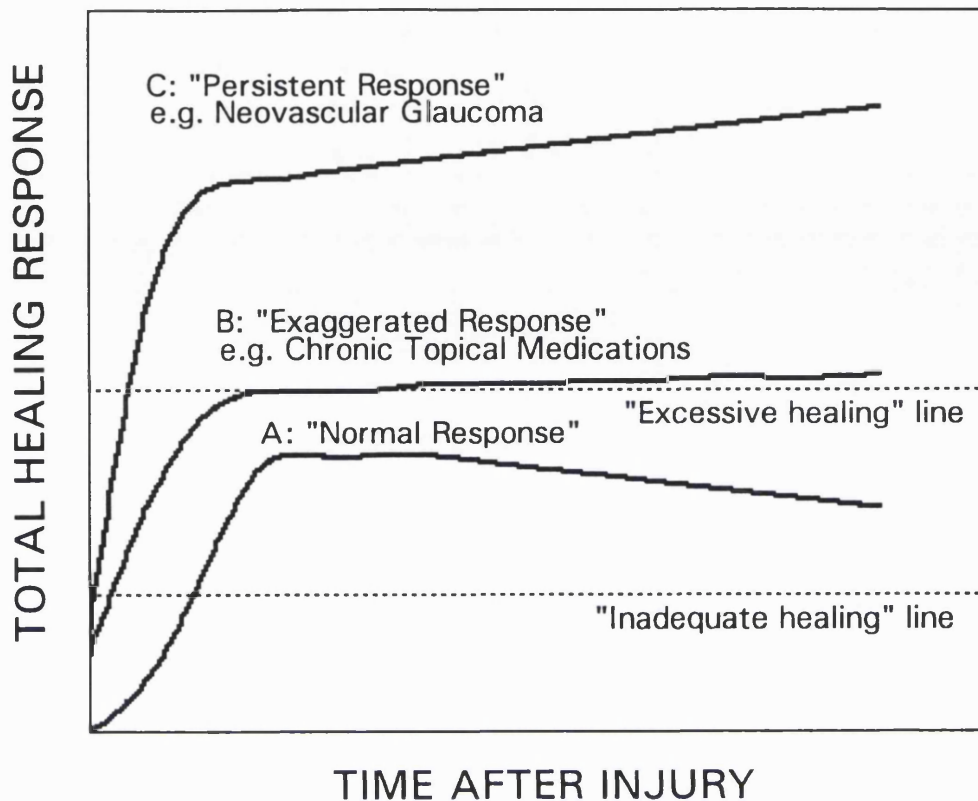
with 5-fluorouracil (50 mg/ml) and a longer lasting effect with mitomycin-c (0.4 mg/ml) (Sherwood et al, 1992; Nordlund et al, 1992). In man, mitomycin-c at a concentration around 0.4 mg/ml may be appropriate in patients in whom there is a long term persistent cellular stimulus in the wound environment, such as a patient with active neovascular glaucoma or uveitis, or other patients who have a prolonged aggressive healing response. This would result in persistent high concentrations of most growth factors. Based on our previous experiments this would result in a continued maximal stimulus for collagen production if there were fibroblasts present. 5-fluorouracil 50 mg/ml may be more appropriate for patients in whom a temporary blunting of the healing response is required, such as low risk patients undergoing primary surgery. This is represented in a model summarised in **figures 65, 66 and 67**. Essentially, this model represents 3 different profiles of healing with a theoretical excessive healing threshold line, which if crossed results in surgical failure. If excessive modulation is achieved, inadequate healing occurs. The theoretical effects of a shorter term inhibition (5-fluorouracil) and a longer term inhibition (mitomycin-c) on these different healing profiles is shown.

The importance of this new model is that it provides us with a biological framework to tailor the use of different agents in varying healing circumstances. However, this is speculative and clinical trials based on this experimental work are in progress to establish whether this is the case. Furthermore, the new concept of being able to induce localised, temporary or long term inhibition of fibroblast proliferation with very short exposures to antiproliferative agents has many potential applications in the control of ocular and orbital scarring, and also scarring in other parts of the body.

#### **4.5 Effects of transforming growth factor- $\beta$ 1 on collagen, lysyl oxidase and transforming growth factor $\beta$ 1 RNA levels and the effect of "growth arrest"**

Based on the results we decided to further examine the effects of the growth factor that seemed to exert the greatest overall change in ocular fibroblast healing behaviour, that is TGF- $\beta$ . RNA levels were measured as we were interested in the effects of the growth factors at the level of transcription, particularly because a disruption of RNA was a possible mechanism of the induced growth arrest observed in earlier experiments. I chose to measure RNA levels of a variety of molecules. Collagen I2 $\alpha$  is representative of collagen transcription as a whole and it is known that TGF- $\beta$  stimulates the mouse collagen promoter (Rossi et al, 1988). The enzyme lysyl oxidase is required to cross link the collagen to produce a stable scar, and finally TGF- $\beta$

Figure 65 Model of different healing profiles after glaucoma filtration surgery.

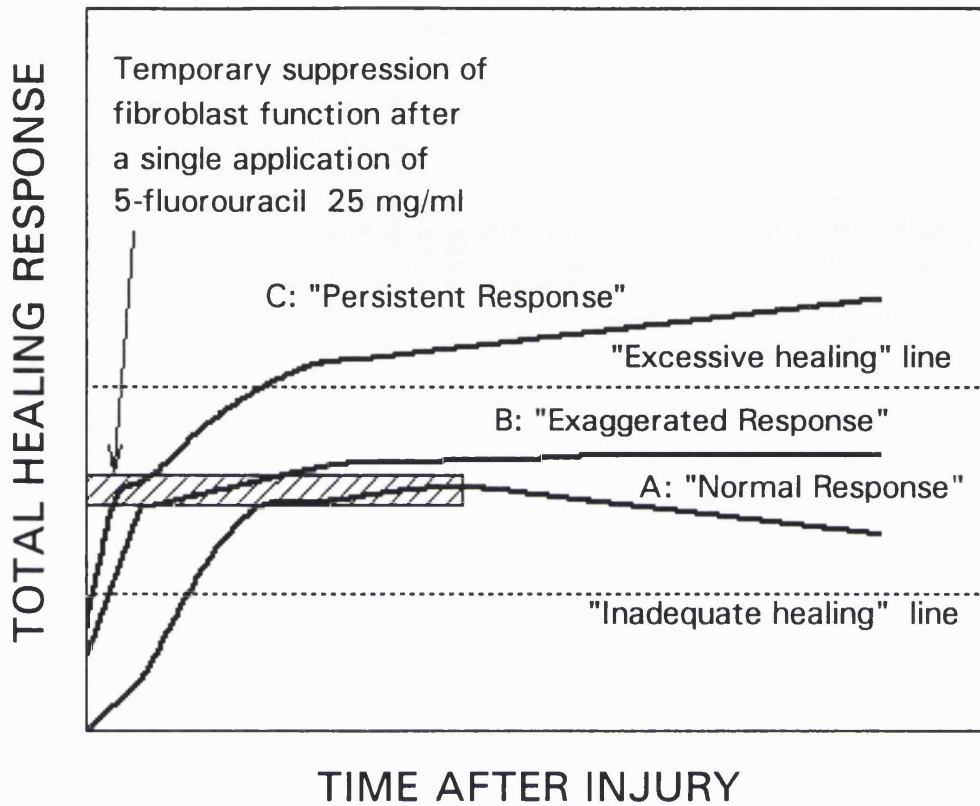


The "normal" healing response (**A**: e.g. elderly caucasian patient without previous topical medications) peaks then rapidly plateaus, possibly with some fall back to baseline as aqueous under the conjunctiva is associated with some bleb thinning. This occurs without crossing above an imaginary "failure line". Neither does the healing fall below another imaginary "inadequate healing" line, below which there may be complications such as hypotony.

**The "exaggerated" healing response (B**: e.g. patient who has received chronic topical medications) starts higher initially and reaches a higher peak compared to normal.

**The "persistent" response (C**: e.g. a patient with neovascular glaucoma and constant stimulation from the aqueous) rises to a high peak response after surgery and this response continues for a very prolonged period.

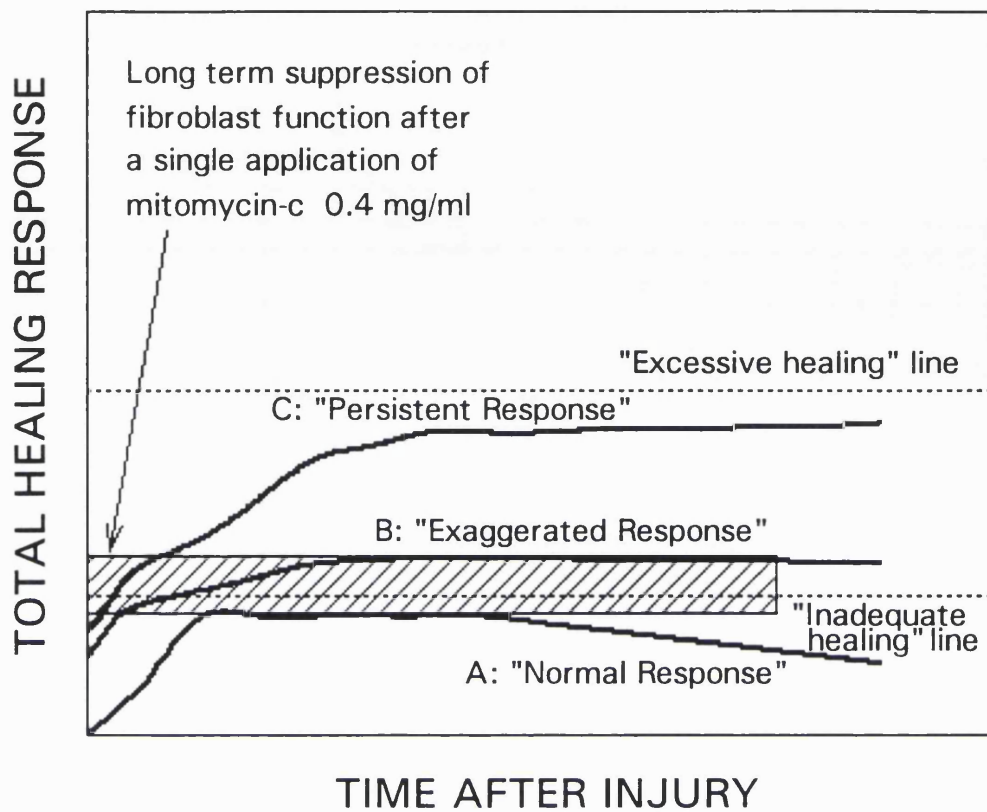
Figure 66 Postulated effect of a single five minute application of 5-fluorouracil.



A single application of 5-fluorouracil causes temporary suppression (weeks) and this is adequate for a "normal" and an "exaggerated" response, but not for higher risk patients with a "persistent response" who then cross the "excessive healing" line and fail surgery.



Figure 67 Postulated effect of a single five minute application of mitomycin-c.



A single application of mitomycin-c suppresses the "persistent" response, but pushes a "normal" response below the "inadequate healing" line, and the "exaggerated" response to the borderline, potentially resulting in hypotony and other complications due to inadequate healing.

stimulates its own gene promoter region. The enzyme superoxide dismutase was chosen as a loading control ("housekeeping" gene) as preliminary experiments revealed that neither TGF- $\beta$  or pharmacological growth arrest appeared to affect the RNA levels of this enzyme.

The experiments showed that TGF- $\beta$ 1 upregulated the RNA levels of collagen I2 $\alpha$  and TGF- $\beta$ 1 itself in ocular fibroblasts confirming previous studies in non-ocular fibroblasts (Raghow et al, 1987; Sporn et al, 1987; Obberghen-Schilling et al, 1988). These experiments have also shown, for the first time that TGF- $\beta$ 1 also upregulates the RNA levels of lysyl oxidase. All these findings contribute to the impression that TGF- $\beta$  is a major contributor to the scarring response and this is one of its major evolutionary roles. It is of interest that the peptide sequences of TGF- $\beta$  are highly conserved across species (Roberts and Sporn, 1993).

Growth arrest of the cells with 5-fluorouracil hardly reduced the RNA levels of Collagen I2 $\alpha$ , and TGF- $\beta$ 1 and did not change the RNA levels of the loading control of superoxide dismutase. However, the RNA levels of lysyl oxidase were very markedly reduced. This was confirmed when the experiment was repeated. These findings are of interest as one of the possible mechanisms of growth arrest is disturbance of RNA function. If RNA disruption was a mechanism of growth arrest one would expect a generalised reduction in RNA levels which was not the case. An alternative explanation is that lysyl oxidase transcription is specifically downregulated in cells growth arrested by 5-fluorouracil, but not in serum starved cells. This may be a possibility as Kenyon and colleagues have postulated that lysyl oxidase as well as being essential for scar formation, is a possible tumour and proliferation suppressor gene (Kenyon et al, 1991). It may be that in the growth arrested cell this gene transcription is downregulated in an attempt to restart cellular proliferation.

The RNA levels of collagen I2 $\alpha$ , TGF- $\beta$ 1 and lysyl oxidase were increased after exposure to TGF- $\beta$ 1 even in growth arrested cells. This suggests that growth arrested cells can still respond to exogenous stimulation by growth factors, at least at the transcriptional level. This provides a link with the experimental findings in the first part of this thesis. Essentially, changes in the concentration of stimulatory factors in the local environment of the wound that we have found stimulate wound healing behaviour in the ocular fibroblast, may be able to reverse the effects of local growth arrest induced by antiproliferative agents. This may help to explain the findings of previous studies where animals treated with systemic antiproliferative agents had impaired healing that improved following treatment with TGF- $\beta$  (Lawrence et al, 1986b).

## 4.6 Conclusions

In this thesis I have shown that chemotactic activity of aqueous humour from patients with cataract and glaucoma are not significantly different, despite differences in the aqueous concentrations of fibronectin. Furthermore fibronectin does not appear to be a major component of the chemotactic response of fibroblasts to aqueous humour. However, growth factors found in the aqueous are able to exert major influences on ocular fibroblast proliferation, migration and collagen production, particularly one growth factor, TGF- $\beta$ 1. The cell culture experiments have shown that very short exposures to antiproliferative agents can produce long term growth arrest of ocular fibroblasts. Applied in an *in vivo* model I have shown that these short single treatments can induce long term inhibition of fibroblast proliferation and associated scarring with single applications of these agents. Furthermore this effect is focal and the duration of effect can be altered by variations in agent and concentration. These new findings have been applied clinically and have led to an anti-scarring regimen that is now commonly used in many centres. Finally, I have also shown that cells respond at the level of transcription to the most stimulatory factor we investigated, TGF- $\beta$  and that this response is still present in cells growth arrested cells.

These experiments have posed many more questions for the future. In particular it is clear that we need to understand much more about the process of cellular growth arrest induced by the antiproliferative agents, and the responsiveness of these cells *in vivo* and *in vitro*. This will be subject of future research in our laboratory.

## REFERENCES

- Aaberg, T.M. Management of anterior and posterior proliferative vitreoretinopathy. *Am.J.Ophthalmol.* 106,5:519-532, 1988.
- Abi-Hanna, D., McCluskey, P. and Wakefield, D. HLA antigens in the iris and aqueous humor gamma interferon levels in anterior uveitis. *Invest.Ophthalmol.Vis.Sci.* 30:990-995, 1989.
- Adams, L.W. and Priestley, G.C. Contraction of collagen lattices by skin fibroblasts: Drug-induced changes. *Arch.Dermatol.Res.* 280:114-118, 1988.
- Addicks, E.M., Quigley, H.A., Green, W.R. and Robin, A.L. Histologic characteristics of filtering blebs in glaucomatous eyes. *Arch.Ophthalmol.* 101:795-798, 1983.
- Albergoni, V., Cassini, A., Favero, N. and Rocco, G.T. Effect of penicillamine on some metals and metalloprotein in the rat. *Biochem.Pharmacol.* 24:1131-1133, 1975.
- Albrink, W.S. and Wallace, A.C. Aqueous humor as a tissue culture nutrient. *Proc.Soc.Exp.Biol.Med.* 77:754-758, 1951.
- Allan, G., Eakins, K.E., Kulkarni, P.S. and Levi, R. Inhibition of thromboxane A2 biosynthesis in human platelets by burimamide. *Br.J.Pharmacol.* 71:157-164, 1980.
- Alvarado, J., Murphy, C. and Juster, R. Trabecular meshwork cellularity in primary open angle glaucoma and non-glaucomatous normals. *Ophthalmology.* 91:564-579, 1984.
- Anderson, D.R. Glaucoma: the damage caused by pressure. XLVI Edward Jackson Memorial Lecture. *Am.J.Ophthalmol.* 108:485-495, 1989.
- Antin, P.R., Forry-Schaudines, S., Friedman, T.M., Tapscott, S.J. and Holtzer, H. Taxol induces postmitotic myoblasts to assemble interdigitating microtubule-myosin arrays that exclude actin filaments. *J.Cell.Biol.* 900:300-308, 1981.
- Anzano, M.A., Roberts, A.B., Smith, J.M. and Sporn, M.B. Anchorage-independent growth of primary rat embryo cells is induced by platelet-derived growth factor and inhibited by type-beta transforming growth factor. *J.Cell.Physiol.* 126:312-318, 1986.
- Armaly, M.F., Krueger, D.E. and Maunder, L. Biostatistical analysis of the collaborative glaucoma study. I. Summary report of the risk factors for glaucomatous visual field defects. *Arch.Ophthalmol.* 98:2163-2167, 1980.
- Assoian, R.K., Fleurdelys, B.E., Stevenson, H.C., Miller, P.J., Madtes, D.K., Raines, E.W., Ross, R.R. and Sporn, M.B. Expression and secretion of type-beta transforming growth factor by activated human macrophages. *Proc.Natl.Acad.Sci.USA.* 84:6020-6024, 1987.
- Assoian, R.K., Grotendorst, G.R., Miller, D.M. and Sporn, M.B. Cellular transformation by coordinated action of three peptide growth factors from human platelets. *Nature.(Lond).* 309:804-806, 1984.
- Assoian, R.K., Komoria, A., Meyers, C.A., Miller, D.M. and Sporn, M.B. Transforming growth factor-beta in human platelets: Identification of a major storage site, purification, and characterization. *J.Cell.Biol.* 258:7155-7160, 1983.
- Assoian, R.K. and Sporn, M.B. Type beta transforming growth factor in human platelets: Release during platelet degranulation and action on vascular smooth muscle cells. *J.Cell.Biol.* 102:1217-1223, 1986.

Baird, A. and Durkin, T. Inhibition of endothelial cell proliferation by type-beta transforming growth factor: Interactions of acidic and basic fibroblast growth factors. *Biochem.Biophys.Res.Comm.* 138:476-482, 1986.

Baird, A., Mormede, P. and Bohlen, P. Immunoreactive fibroblast growth factor in cells of peritoneal exudate suggests its identity with macrophage-derived growth factor. *Biochem.Biophys.Res.Comm.* 126:358-364, 1985.

Ball, S.F., Morsey, M.S. and Tamaki, K. Triamcinolone and subconjunctival fibrosis in rabbits. *Invest.Ophthalmol.Vis.Sci.(Suppl)*. 163, 1986.

Bancroft, J.D. and Cook, H.C. *Manual of histological techniques*, Edinburgh:Churchill Livingstone, 1984.

Barlatti, S., Marchina, E., Quaranta, C.A., Vigasio, F. and Semeraro, F. Analysis of fibronectin, plasminogen activators and plasminogen in tear fluid as markers of corneal damage and repair. *Exp.Eye.Res.* 51:1-9, 1990.

Barritault, D., Arruti, C. and Courtois, Y. Is there a ubiquitous growth factor in the eye? Proliferation induced in different types by eye-derived growth factors. *Differentiation*. 18:29-42, 1981.

Baserga, R. *The biology of cell reproduction*, Cambridge USA:Harvard University Press, 1985.

Bashkin, P., Doctrow, S., Klagsbrun, M., Svahn, C.M., Folkman, J. and Vlodavsky, I. Basic fibroblast growth factor binds to subendothelial extracellular matrix and is released by heparitinase and heparin-like molecules. *Biochemistry*. 28:1737-1743, 1989.

Basnett, S. and Beebe, D.C. Localization of insulin-like growth factor-1 binding sites in the embryonic chicken eye. *Invest.Ophthalmol.Vis.Sci.* 31:1637-1643, 1990.

Beebe, D.C., Feagans, D.E. and Jebens, H.H. Lentropin: A factor in vitreous humor which promotes lens fibre cell differentiation. *Proc.Natl.Acad.Sci.USA*. 77:490-493, 1980.

Beebe, D.C., Silver, M.H., Belcher, K.S., Van Wyke, J.J., Svoboda, M.E. and Zelenka, P.S. Lentropin, a protein that controls lens fibre formation, is related functionally and immunologically to the insulin-like growth factors. *Proc.Natl.Acad.Sci.USA*. 84:2327-2330, 1987.

Benedikt, O.P. Drainage mechanism after filtration. *Glaucoma*. 1:71-77, 1979.

Berson, .D, Landau, L, Zauberman, H and Blumenthal, M Filtering operations in Africans. *Am J Ophthalmol* 67:395-398, 1969.

Bergstrom, T.J., Wilkinson, W.S., Skuta, G.L., Watnick, R.L. and Elner, V.M. The effects of subconjunctival mitomycin-c on glaucoma filtration surgery in rabbits. *Arch.Ophthalmol*. 109:1725-1730, 1991.

Bito, L.Z. Species differences in the response of the eye to irritation and trauma: A hypothesis of divergence in ocular defense mechanisms, and the choice of experimental animals for eye research. *Exp.Eye.Res.* 39:807, 1984.

Blumenkranz, M.S., Claflin, A.J. and Hajek, A.S. Selection of therapeutic agents for intraocular proliferative disease: Cell culture evaluation. *Arch.Ophthalmol*. 102:598-604, 1984a.

Blumenkranz, M.S., Claflin, A.J. and Hajek, A.S. Selection of therapeutic agents for intraocular proliferative disease: Cell culture evaluation. *Arch.Ophthalmol*. 102:598-604, 1984b.

- Blumenkranz, M.S., Hartzler, M.K. and Iverson, D. An overview of potential applications of heparin in vitreoretinal surgery. *Retina*. 12:s71-s74, 1992.
- Blumenkranz, M.S., Ophir, A., Clafin, A.J. and Hajek, A.S. Fluorouracil for the treatment of massive periretinal proliferation. *Am.J.Ophthalmol.* 94:458-467, 1982.
- Bode, A.P., Dombrose, F.A., Lentz, B.R. and Roberts, H.R. The platelet membrane as a catalytic surface in thrombin generation: Availability of platelet Factor 1 and platelet Factor 3. *Ann.NY.Acad.Sci.* 370:348-358, 1981.
- Boffa, L.C., Vidali, G., Mann, R.S. and Allfrey, V.G. Suppression of histone deacetylation in vivo and in vitro by sodium butyrate. *J.Biol.Chem.* 253:3364-3365, 1978.
- Borisy, G.G. and Taylor, E.W. The mechanism of action of colchicine: Binding of colchicine-H3 to cellular protein. *J.Cell.Biol.* 34:525-533, 1984.
- Boucek, R.J. Factors affecting wound healing. *Otolaryngeal.Clin.North.Am.* 17/2:243-264, 1984.
- Bowen, D., Diasio, R.B. and Goldman, I.D. Distinguishing between membrane transport and intracellular metabolism of fluorodeoxyuridine in ehrlich ascites tumor cells by application of kinetic and high performance liquid chromatographic techniques. *J.Biol.Chem.* 254:5333-5339, 1979.
- Bowersox, J.C. and Sorgente, N. Chemotaxis of aortic endothelial cells in response to fibronectin. *Cancer.Res.* 42:2547-2551, 1982.
- Boyden, S. The chemotactic effect of mixtures of antibody and antigen on polymorphonuclear leucocytes. *J.Exp.Med.* 115:453-466, 1962.
- Brazzell, K.R., Stern, M.E., Aquavella, J.V., Beuerman, R.W. and Baird, L. Human recombinant epidermal growth factor in experimental corneal wound healing. *Invest.Ophthalmol.Vis.Sci.* 32:336, 1991.
- Brightwell, J.R., Riddle, S.L., Eiferman, R.A., Valenzuela, P., Barr, P.J., Merryweather, J.P. and Schultz, G.S. Biosynthetic human EGF accelerates healing of neodacardron-treated primates corneas. *Invest.Ophthalmol.Vis.Sci.* 26:105-110, 1985.
- Buck, C.A. and Horwitz, A.F. Cell surface receptors for extracellular matrix molecules. *Ann.Rev.Cell.Biol.* 3:179-205, 1987.
- Buckley, A., Davidson, J.M., Kamerath, C.D., Wolt, T.B. and Woodward, S.C. Sustained release of epidermal growth factor accelerates wound repair. *Proc.Natl.Acad.Sci.USA.* 82:7340-7344, 1985.
- Buckley-Sturrock, A., Woodward, S.C., Senior, R.M., Griffin, G.L., Klagsbrun, M. and Davidson, J.M. Differential stimulation of collagenase and chemotactic activity in fibroblasts derived from rat wound repair tissue and human skin by growth factors. *J.Cell.Physiol.* 138:70-78, 1989.
- Bunting, S., Gryglewski, R., Moncada, S. and Vane, J.R. Arterial walls generate from prostaglandin endoperoxides a substance (prostaglandin X) which relaxes strips of mesenteric and coeliac arteries and inhibits platelet aggregation. *Prostaglandins.* 12:897-913, 1976.
- Burke, J., Foster, S. and Herschler, J. Aqueous humour as a modulator of growth in fibroblast cultures. *Curr.Eye.Res.* /1983.2:835-841, 1982.
- Burstein, N.L. Review: Growth factor effects on corneal wound healing. *J.Ocul.Pharmacol.* 3:263-277, 1987.

- Cairns, J.E. Trabeculectomy: Preliminary report of a new method. **Am.J.Ophthalmol.** 66:673-679, 1968.
- Calthorpe, C.M. and Grierson, I. Fibronectin induces migration of bovine trabecular meshwork cells in vitro. **Exp.Eye.Res.** 51:39-48, 1990.
- Campochiaro, P.A., Bryan, J.A., Conway, B.P. and Jaccoma, E.H. Intravitreal chemotactic and mitogenic activity. Complication of blood-retinal barrier breakdown. **Arch.Ophthalmol.** 104:1685-1687, 1986.
- Campochiaro, P.A. and Conway, B.P. Quantitation of aphakic cystoid macular oedema with vitreous fluorophotometry. **Invest.Ophthalmol.Vis.Sci.** 20(suppl):236, 1981.
- Campochiaro, P.A., Hackett, S.F. and Conway, B.P. Retinoic acid promotes density dependent growth arrest in human retinal pigment epithelial cells. **Invest.Ophthalmol.Vis.Sci.** 32:65-72, 1991.
- Campochiaro, P.A., Jerdan, J.A., Glaser, B.M., Cardin, A. and Michels, R.G. Vitreous aspirates from patients with proliferative vitreoretinopathy stimulate retinal pigment epithelial cell migration. **Arch.Ophthalmol.** 103:1403-1405, 1985.
- Canalis, E. and Raisz, L.G. Effect of epidermal growth factor on bone formation in vitro. **Endocrinology.** 104:862-869, 1979.
- Carrico, C.K. and Glazer, R.I. Augmentation by thymidine of the incorporation and distribution of 5-fluorouracil into ribosomal RNA. **Biochem.Biophys.Res.Commun.** 87:664-670, 1979a.
- Carrico, C.K. and Glazer, R.I. The effect of 5-fluorouracil and the synthesis and translation of poly (A) RNA from re-generating. **Cancer.Res.** 39:3694-3701, 1979b.
- Castro, J., Virgo, J.F., Larranaga Cordido, J., Sabugal, J. and Diaz, J.A. Insulin like growth factor (IGF-1) in aqueous humor. Study in non diabetic and diabetic patients. **Invest.Ophthalmol.Vis.Sci.(Suppl).** 31:196, 1990.
- Chahal, S.S., Matthews, H.R. and Bradbury, E.M. Acetylation of Histone H4 and its role in chromatin structure and function. **Nature.** 287:76-79, 1980.
- Champe, S.P. and Benzer, S. Reversal of mutant phenotypes by 5-fluorouracil: An approach to nucleotide sequences in messenger-RNA. **Proc.Natl.Acad.Sci.USA.** 48:532-546, 1962.
- Chandler, D.B., Hida, T., Rozakis, G., Forbes, V.S. and Machemer, R. The lack of an effect of intraocular steroids on irradiated fibroblasts in experimental proliferative vitreoretinopathy. **Graefes.Arch.Clin.Exp.Ophthalmol.** 230:188-191, 1992.
- Chapman-Smith, J.S. and Crock, G.W. Urokinase in the management of vitreous haemorrhage. **Br.J.Ophthalmol.** 61:500-505, 1977.
- Chaudhuri, N.K., Montag, B.J. and Heidelberger, C. Studies on fluorinated pyrimidines III. The metabolism of 5-fluorouracil-2-C(14) and 5-fluoroorotic-2-C(14) acid in vivo. **Cancer.Res.** 18:318-328, 1958.
- Chen, C-W., Huang, H-T., Bair, J.S. and Lee, C-C. Trabeculectomy with simultaneous topical application of mitomycin-c in refractory glaucoma. **J.Ocul.Pharmacol.** 6:175-182, 1990.
- Chen, C.W. Enhanced intraocular pressure controlling effectiveness of trabeculectomy by local application of mitomycin c. **Trans.Asia.Pacif.Acad.Ophthalmol.** 9:172-177, 1983.

Chen, C.W., Huang, H.T. and Sheu, M.M. Enhancement of IOP control effect of trabeculectomy by local application of anticancer drug. In: *Proceedings of the XXVth international congress of ophthalmology, Rome, Italy*, edited by Blodi, F., Brancato, R., Cristini, G., d'Ermo, F., Esente, I., Musini, A., Philipson, B., Pintucci, F., Ponte, F. and Scuderi, G. Amsterdam: Kugler and Ghedini, 1987, p. 1487-1491.

Chen, D.M., DiSabato, G., Field, L., Gallo, A.A. and Harshman, S. Some immunological effects of penicillamine. *Clin.Exp.Immunol.* 30:317, 1977.

Chen, J-K., Hoshi, H. and McKeehan, W.L. Transforming growth factor beta specifically stimulates synthesis of proteoglycan in human arterial smooth muscle cells. *Proc.Nat.Acad.Sci.USA.* 84:5287-5291, 1987.

Chen, L.B., Gudor, R.C., Sun, T-T., Chen, A.B. and Mosesson, M.W. Control of a cell surface major glycoprotein by epidermal growth factor. *Science.* 197:776-778, 1977.

Chi, H.H., Teng, C.C. and Katzin, E.M. Aqueous degenerative effect and the protective role of endothelium in eye pathology. *Am.J.Ophthalmol.* 50:365-379, 1960.

Chirgwin, J.M., Przybyla, A.E., MacDonald, R.J. and Rutter, W.J. Isolation of biologically active ribonucleic acid from sources enriched in ribonuclease. *Biochemistry.* 18:5294-5299, 1979.

Chua, C.C., Geiman, D.E., Keller, G.H. and Ladda, R.L. Induction of collagenase secretion in human fibroblast cultures by growth promoting factors. *J.Biol.Chem.* 260:5212-5216, 1985.

Chvapil, M. and Koopmann, C.F. Scar formation: Physiology and pathology states. *Otolaryngeal.Clin.North.Am.* 17/2:265-272, 1984.

Clark, J.G., Kahn, C., McDonald, J.A. and Mecham, R.P. Lung connective tissue. *Int.Rev.Connect.Tissue.Res.* 10:249-331, 1983.

Clark, R.A.F. and Henson, P.M. *The molecular and cellular biology of wound repair*, New York:Plenum Press, 1988.

Clark, R.A.F., Quinn, J.H., Winn, H.J., Lanigan, J.M., DellaPelle, P. and Colvin, R.B. Fibronectin is produced by blood vessels in response to injury. *J.Exp.Med.* 156:646-651, 1982.

Clark, R.A.F., Winn, H.J., Dvorak, H.F. and Colvin, R.B. Fibronectin beneath reepithelializing epidermis in vivo: Sources and significance. *J.Invest.Dermatol.* 80:26s-30s, 1983.

Clemmons, D.R., Isley, W.L. and Brown, M.T. Dialyzable factor in human serum of platelet origin stimulates endothelial cell replication and growth. *Proc.Natl.Acad.Sci.USA.* 80:1641-1645, 1983.

Clemons, D.R., Underwood, L.E. and Van Wyk, J.J. Hormonal control of immuno reactive somatomedine produced cultured human fibroblasts. *J.Clin.Invest.* 67:10-19, 1981.

Cochran, B.H., Wulfo, J., Verma, I.M. and Stiles, C.D. Expression of the c-fos gene and of a fos-related gene is stimulated by platelet-derived growth factor. *Science.* 42:23-38, 1984.

Cohen, S. Isolation of a mouse submaxillary gland protein accelerating incisor eruption and eyelid opening in the newborn animal. *J.Biol.Chem.* 237:1555-1562, 1962.

Cohen, S. Epidermal growth factor. *In.Vitro.Cell.Dev.Biol.* 23:239-246, 1987.

Cohen, S.S., Flaks, J.G., Barmer, H.D., Love, M.R. and Lichtstein, J. The mode of action of 5-fluorouracil as it's deregatives. *Proc.Natl.Acad.Sci.USA.* 44:1004-1012, 1958.



- Colvin, M. Alkylating agents. In: *Pharmacological principles of cancer treatment*, Philadelphia: W.B. Saunders, 1982, p. 276-308.
- Connor, T.B., Roberts, A.B., Sporn, M.B., Danielpour, D., Dart, L.L., Michels, R.G., de Busto, S., Davis, J. and Glaser, B.M. RPE cells synthesize and release transforming growth factor-B, a modulator of endothelial cell growth and wound healing. *Invest.Ophthalmol.Vis.Sci.(Suppl)*. 29:307, 1988.
- Connor, T.B., Roberts, A.B., Sporn, M.B., Danielpour, D., Dart, L.L., Micehls, R.G., de Bustros, S., Enger, C., Kato, H., Lansing, M., Hayashi, H. and Glaser, B.M. Correlation of fibrosis and transforming growth factor-B type 2 levels in the eye. *J.Clin.Invest*. 83:1661-1666, 1989.
- Conover, C.A., Hintz, R.L. and Rosenfeld, R.G. Comparative effects of somatomedine C and insulin on the metabolism and growth of cultured human fibroblast. *J.Cell.Physiol*. 122:133-141, 1985.
- Conover, C.A., Rosenfeld, R.G. and Hintz, R.L. Hormonal control of the replication of human fetal fibroblasts: Role of somatomedine C/insulin-like growth factor 1. *J.Cell.Physiol*. 128:47-54, 1986.
- Cook, P.R. and Brazell, I.A. Detection and repair of single strand breaks in nuclear DNA. *Nature*. 263:619, 1976.
- Couch, J., Cullen, P., Casey, T. and Fabre, J. Mitotic activity of corneal wound endothelial cells in organ culture with recombinant human epidermal growth factor. *Ophthalmology*. 94:1-6, 1987.
- Crick, R.P. Early detection of glaucoma. *Br.Med.J*. 285:1063-1064, 1982.
- Damsky, C.H., Knudsen, K.A., Bradley, D., Buck, C.A. and Horwitz, A.F. Distribution of the cell substratum attachment (CSAT) antigen on myogenic and fibroblastic cells in culture. *J.Cell.Biol*. 100:1528-1539, 1985.
- Daniele, S., Frati, L., Flore, C. and Santoni, G. The effect of the epidermal growth factor (EGF) on the corneal epithelium in humans. *Graefe's.Arch.Clin.Exp.Ophthalmol*. 210:159-165, 1979.
- Danielpour, D., Dart, L.L., Flanders, K.C., Roberts, A.B. and Sporn, M.B. Immunodetection and quantification of the 2 forms of transforming growth factor-beta (TGF-B1 and (TGF-B2) secreted by cells in culture. *J.Cell.Physiol*. 138:79-86, 1989.
- Danneberg, P.B., Montag, B.J. and Heidelberger, C. Studies on fluorinated pyrimidines IV. Effects on neucleic acid metabolism in vivo. *Cancer.Res*. 18:329-334, 1958.
- Dano, K., Andreasen, P.A., Grondahl-Hansen, J., Kristensen, P., Nielsen, L.S. and Skriver, L. Plasminogen activators, tissue degradation, and cancer. *Adv.Cancer.Res*. 44:139-266, 1985.
- Davidson, C., Green, W.R. and Wong, V.G. Retinal atrophy induced by intravitreal colchicine. *Invest.Ophthalmol.Vis.Sci*. 24:301-311, 1983.
- Davidson, J.S, Klagsbrun, M., Hills, K., Buckley, A., Sullivan, R., Brewer, P. and Woodward, S. Accelerated wound repair, cell proliferation and collagen accumulation are produced by a cartilage derived growth factor. *J.Cell.Biol*. 100:1219-1227, 1985.
- Davie, E.W. Introduction to the blood coagulation cascade and the cloning of blood coagulation factors. *J.Protein.Chem*. 5:247-253, 1986.
- Dehm, P. and Prockop, D.J. Time lag in the secretion of collagen by matrix-free tendon cells and inhibition of the secretory process by colchicine and vinblastine. *Biochim.Biophys.Acta*. 264:375-382, 1972.

- Dernouchamps, J.P. The proteins of the aqueous humour. *Doc.Ophthalmol.* 53:193-248, 1982.
- Desjardins, D.C., Parish, R.K., Folberg, R., Nevarez, J., Heuer, D.K. and Gressel, M.G. Wound healing after filtering surgery in owl monkeys. *Arch.Ophthalmol.* 104:1835-1839, 1986.
- Desjardins, D.C., Parrish, R.K., Folberg, R., Nevarez, J., Heuer, D.K. and Gressel, M.G. Wound healing after filtering surgery in owl monkeys. *Arch.Ophthalmol.* 104:1835-1839, 1986.
- Deuel, T.F. and Huang, J.S. Platelet-derived growth factor: Purification, properties and biological activities. *Prog.Hematol.* 13:201-221, 1983.
- Deuel, T.F. and Huang, J.S. Platelet derived growth factor: Structure, function and roles in normal and transformed cells. *J.Clin.Invest.* 74:669-676, 1984.
- Deuel, T.F., Senior, R.M., Chang, D., Griffin, G.L., Henrikson, R.L. and Katser, E.T. Platelet factor 4 is chemotactic for neutrophils and monocytes. *Proc.Natl.Acad.Sci.USA.* 78:4584-4587, 1981.
- Deuel, T.F., Senior, R.M., Huang, J.S. and Griffin, G.L. Chemotaxis of monocytes and neutrophils to platelet derived growth factor. *J.Clin.Invest.* 69:1046-1049, 1982a.
- Deuel, T.F., Senior, R.M., Huang, J.S. and Griffin, G.L. Chemotaxis of monocytes and neutrophils to platelet derived growth factor. *J.Clin.Invest.* 69:1046-1049, 1982b.
- DiCorleto, P.E. and Bowen-Pope, D.F. Cultured endothelial cells produce a platelet derived growth factor like protein. *Proc.Natl.Acad.Sci.USA.* 80:1919-1923, 1983.
- Diegelmann, R.F., Bryson, G.R., Flood, L.C. and Graham, M.F. A microassay to quantitate collagen synthesis by cells in culture. *Anal.Biochem.* 186:296-300, 1990.
- Diegelmann, R.F. and Peterkofsky, B. Inhibition of collagen secretion from bone and cultured fibroblasts by microtubular disruptive drugs. *Proc.Natl.Acad.Sci.USA.* 69:892-896, 1972.
- Duthu, G.S. and Smith, J.R. In vitro proliferation and lifespan of bovine aorta endothelial cells: Effects of culture conditions and fibroblast growth factor. *J.Cell.Physiol.* 103:385-392, 1980.
- Dvorak, H.F. Tumour: wounds that do not heal. Similarities between tumour stroma generation and wound healing. *N.Eng.J.Med.* 315:1650-1659, 1986.
- Dvorak, H.F., Senger, D.R., Dvorak, A.M., Harvey, V.S. and McDonagh, J. Regulation of extravascular coagulation by microvascular permeability. *Science.* 227:1059-1061, 1985.
- Eakins, K.E. Prostaglandin and non prostaglandin breakdown of blood-aqueous barrier. In "The ocular and cerebrospinal fluid". *Exp.Eye.Res.* 483-498, 1977.
- Eakins, K.E., Atwal, M. and Bhattacharjee, P. Inactivation of prostaglandin E1 by ocular tissue in vitro. *Exp.Eye.Res.* 19:141-146, 1974.
- Edwards, D.R., Murphy, G., Reynolds, J.J., Whitman, S.E., Docherty, A.J.P., Angel, P. and Heath, J.K. Transforming growth factor beta modulates the expression of collagenase and metalloproteinase inhibitor. *EMBO.J.* 6:1899-1904, 1987.
- Ehrlich, H.P., Griswold, T.R. and Rajaratnam, J.B.M. Studies on vascular smooth muscle cells and dermal fibroblasts in collagen matrices; effects of heparin. *Exp.Cell.Res.* 164:154-162, 1986.
- Ehrlich, H.P. and Hunt, T.K. The effects of cortisone and anabolic steroids on the tensile strength of healing wounds. *Ann.Surg.* 170:203-206, 1969.

- Ellis, H. The causes and prevention of intestinal adhesions. **Br.J.Surg.** 69:241-243, 1982.
- Engvall, E. and Perlmann, P. . **Immunochemistry.** 8:871, 1971.
- Esch, F., Baird, A., Ling, N., Ueno, N., Hill, F., Denoroy, L., Klepper, R., Gospodarowicz, D., Bohlen, P. and Guillemin, R. Primary structure of bovine pituitary basic fibroblast growth factor (FGF) and comparison with the amino-terminal sequence of bovine brain acidic FGF. **Proc.Natl.Acad.Sci.USA.** 82:6507-6511, 1985.
- Esch, F., Ueno, N. and Baird, A. Primary structure of bovine brain acidic fibroblast growth factor (FGF). **Biochem.Biophys.Res.Comm.** 562, 1985.
- Evans, R.M., Laskin, J.D. and Hakala, M.T. Assessment of growth-limiting events caused by 5-fluorouracil in mouse cells and in human cells. **Cancer.Res.** 40:4113-4122, 1980.
- Fabricant, R.N., Alpar, A.J., Centifanto, Y.M. and Kaufman, H.E. Epidermal growth factor receptors on corneal endothelium. **Arch.Ophthalmol.** 99:305, 1981.
- Falanga, V., Tiegs, S.L., Alstadt, S.P., Roberts, A.B. and Sporn, M.B. Transforming growth factor beta: Selective increase in glycosamino glycan synthesis in by cultures of fibroblasts from patients with systemic sclrosis. **J.Invest.Dermatol.** 89:100-104, 1987.
- Fantes, F.E., Heuer, D.K. and Parrish, R.K.II. Topical fluorouracil; pharmacokinetics in normal rabbit eyes. **Arch.Ophthalmol.** 103:953-955, 1985.
- Feinberg, A.P. and Vogelstein, B. A technique for radiolabelling DNA restriction endonucleases fragments to high specific activity. **Analyt.Biochem.** 132:6-13, 1983.
- Ferguson, M.K. The effect of antieoplastic agents on wound healing. **Surg.Gynecol.Obstet.** 154:421-429, 1982.
- Fisher, D.A., Salido, E.C. and Barajas, L. Epidermal growth factor and the kidney. **Annu.Rev.Physiol.** 51:67-80, 1989.
- Flower, R.J. and Blackwell, G.J. Anti-inflammatory steroids induced biosynthesis of phospholipase A2 inhibitor which prevents prostaglandin generation. **Nature.** 278:456-459, 1979.
- Flower, R.J. and Vane, J.R. Some pharmacological and biochemical aspects of prostaglandin biosynthesis and its inhibition. In prostaglandin synthetase inhibitors. In: , Oxford: Raven Press, 1974, p. 9.
- Folkman, J. and Klagsbrun, M. Angiogenic factors. **Science.** 235:442-447, 1987.
- Folkman, J., Klagsbrun, M. and Sasse, J. A heparin-binding angiogenic protein, basic fibroblast growth factor, is stored within basement membrane. **Am.J.Pathol.** 130:393-400, 1988.
- Foster, A. and Johnson, G.J. Magnitude and causes of blindness in the developing world. **Int.Ophthalmol.** 14:135-140, 1990.
- Fredj, Reygrobellet,D., Plouet, J., Delayre, Th., Baudouin, Ch., Bourret, F. and Lapalus, Ph. Effects of aFGF and bFGF on wound healing in rabbit corneas. **Curr.Eye.Res.** 6:1205, 1987.
- Freshney, R.I. *Cultute of animal cells. A manual of basic technique*, New York:Alan R.Liss,Inc., 1987. Ed. 2nd
- Friedman, M.W. Streptokinase in ohthalmology. **Am.J.Ophthalmol.** 35:1184-1187, 1952.

- Furcht, L.T. Structure and function of the adhesive glycoprotein fibronectin. *Mol.Cell.Biol.* 1:53-117, 1983.
- Gabbiani, G., Lelous, M., Bailey, A.J. and DeLauney, A. Collagen and myofibrils of granulation tissue. A chemical, ultrastructural and immunologic study. *Virchows.Arch.(Cell.Pathol.)* 21:133-145, 1976.
- Gabbiani, G. and Montandon, D. Reparative processes in mammalian wound healing: The role of contractile phenomena. *Int.Rev.Cytol.* 48:187-219, 1977.
- Gallin, J.I. and Kaplan, A.P. Mononuclear cell chemotactic activity of kallikrein and plasminogen activator and its inhibition by C1 inhibitor and alpha 2 macroglobulin. *J.Immunol.* 113:1928-1934, 1974.
- Giamgiacomo, J., Dueker, D.K. and Adelstein, E. The effect of subconjunctival triamcinolone administration on glaucoma filtration. I. Trabeculectomy following subconjunctival triamcinolone. *Arch.Ophthalmol.* 104:838-841, 1986.
- Ginburg, E., Salomon, D., Sreevalsan, T. and Freese, E. Growth inhibition and morphological changes caused by lipophilic acids in mammalian cells. *Proc.Nat.Acad.Sci.USA.* 70:2457-2461, 1973.
- Girard, M.T., Matsubara, M. and Fini, M.E. Transforming growth factor-beta and interleukin-1 modulate metalloproteinase expression by corneal stromal cells. *Invest.Ophth.Vis.Sci.* 32:2441-2454, 1991.
- Glazer, R.I. and Legraverend, M. The effect of 5-fluorouridine-triphosphate on RNA transcribed in isolated nuclei in vitro. *Mol.Pharmacol.* 17:279-282, 1980.
- Goldberg, A.R., Machledt, J.H. and Pardee, A.B. On the action of fluorouracil on leukemia cells. *Cancer.Res.* 26:1611-1615, 1966.
- Gospodarowicz, D. Fibroblast and epidermal growth factors: their uses in vivo and in vitro in studies on cell functions and cell transplantation. *Mol.Cell.Biochem.* 25:79-110, 1979.
- Gospodarowicz, D. Epidermal and nerve growth factors in mammalian development. *Annu.Rev.Physiol.* 43:251-263, 1981.
- Gospodarowicz, D. *Hormonal Proteins and Peptides Volume XII*, New York:Academic, 1984. pp. 205-230.
- Gospodarowicz, D. and Bialecki, H. The effects of epidermal and fibroblast growth factors on the replicative lifespan of cultured bovine granulosa cells. *Endocrinology.* 103:854-858, 1978.
- Gospodarowicz, D., Bialecki, H. and Thakral, T.K. The angiogenic activity of the fibroblast and epidermal growth factor. *Exp.Eye.Res.* 28:501-514, 1979.
- Gospodarowicz, D., Massoglia, S., Cheng, J., Lui, G-M. and Bohlen, P. Isolation of pituitary fibroblast growth factor by fast protein liquid chromatography (FPLC): Partial chemical and biological characterization. *J.Cell.Physiol.* 122:323-332, 1985.
- Gospodarowicz, D., Mescher, A.L., Brown, K.D. and Birdwell, C.R. The role of fibroblast growth factor and epidermal growth factor in the proliferative response of the corneal and lens epithelium. *Exp.Eye.Res.* 25:631-649, 1977.
- Gospodarowicz, D., Mescher, L. and Birdwell, C.R. Stimulation of corneal endothelial cell proliferation on vitro by fibroblast and epidermal growth factors. *Exp.Eye.Res.* 25:75-89, 1977.

Gospodarowicz, D., Neufeld, G. and Schweigerer, L. Molecular and biological characterization of fibroblast growth factor, an angiogenic factor which also controls the proliferation and differentiation of mesoderm and neuroectoderm derived cells. *Cell.Differentiation*. 19:1-17, 1986.

Granstein, R.D., Staszewski, R., Knisely, T.L., Zevia, E., Nazareno, R., Latina, M. and Albert, D.M. Aqueous humor contains transforming growth factor-Beta and a small (<3500 daltons) inhibitor of thymocyte proliferation. *J.Immunol*. 144:3021-3027, 1990.

Grant, M.B., Khaw, P.T., Schultz, G.S., Adams, J. and Shimizu, R. Effects of epidermal growth factor, fibroblast growth factor, and transforming growth factor-B on corneal cell chemotaxis. *Invest.Ophthalmol.Vis.Sci*. 33:3292-3301, 1992.

Gressel, M.G., Parrish, R.K.II. and Folberg, R. 5-fluorouracil and glaucoma filtering surgery: I. An animal model. *Ophthalmology*. 91:378-383, 1984.

Grierson, I. and Howes, R. Age related depletion of the cell population in the human trabecular meshwork. *Eye*. 1:204-210, 1987.

Grierson, I., Joseph, J., Miller, M. and Day, J.E. Wound repair: The fibroblast and the inhibition of scar formation. *Eye*. 2:135-148, 1988.

Grierson, I. and Lee, W.R. Erythrocyte phagocytosis in the human trabecular meshwork. *Br.J.Ophthalmol*. 57:400-415, 1973.

Grierson, I., Wang, Q., McMenamin, P.G. and Lee, W.R. The effect of age and antiglaucoma drugs on the meshwork cell population. *Res.Clin.Forums*. 4:69-92, 1982.

Grillo, H.C. and Potsaid, M.S. Retardation of contraction by local x-irradiation and observations relating to the origin of fibroblasts in repair. *Ann.Surg*. 154:741-750, 1961.

Grinnell, F. Fibronectin and wound healing. *J.Cell.Biochem*. 26:107-116, 1984.

Grinnell, F., Billingham, R.E. and Burgess, L. Distribution of fibronectin during wound healing in vivo. *J.Invest.Dermatol*. 76:181-189, 1981.

Grotendorst, G.R., Martin, G.R., Pencev, D., Sodek, J. and Harvey, A.K. Stimulation of granulation tissue by platelet derived growth factor in normal and diabetic rats. *J.Clin.Invest*. 76:2323-2329, 1985.

Grotendorst, G.R., Seppa, H.E.J., Kleinman, H.K. and Martin, G.R. Attachment of smooth muscle cells to collagen and their migration toward platelet-derived growth factor. *Proc.Natl.Acad.Sci.USA*. 78:3669-3672, 1981.

Guber, S. and Ross, R. The myofibroblast. *Surg.Gynecol.Obstet*. 146:641-649, 1978.

Guzman, G., Javitt, J., Glick, H., Tielsch, J. and McDonald, R. Glaucoma in the United States population: the economic burden of illness. *Invest.Ophthalmol.Vis.Sci.(Suppl)*. 33:759, 1992.(Abstract)

Hall, E.J. *Radiobiology for the radiologist*, Philadelphia.:Lippincott., 1988. Ed. 3rd

Hamberg, M., Svensson, J. and Samuelsson, B. Thromboxanes: A new group of biologically active compounds derived from prostaglandin endoperoxides. *Proc.Natl.Acad.Sci.USA*. 72:2994-2998, 1975.

Harbers, E., Chaudhuri, N.K. and Heidelberger, C. Studies on fluorinated pyrimidines VIII. Further biochemical and metabolic investigations. *Cancer.Res*. 234:1255-1262, 1958.

- Harris, A.K., Stopak, D. and Wild, P. Fibroblast traction as a mechanism of for collagen morphogenesis. *Nature*. 290:249-251, 1981.
- Harris, A.K., Wild, P. and Stopak, D. Silicone rubber substrata: A new wrinkle in the study of cell location. *Science*. 208:177-179, 1980.
- Harris, E.D. and Krane, S.M. Effects of colchicine on collagenase in cultures of rheumatoid synovium. *Arthritis.Rheum.* 14:669-684, 1971.
- Hartzer, M.K., Blumenkranz, M.S., Hajek, A.S., Dailey, W.A., Cheng, M. and Margherio, A.R. Selection of therapeutic agents for intraocular proliferative disease III. Effects of fluoropyrimidines on cell-mediated contraction of human fibroblasts. *Exp.Eye.Res.* 48:321-328, 1989.
- Heath, T.D., Brown, C.S. and Stern, W.H. Ocular cicatricial disease; drug effects in vitro on cell proliferation, contraction, and viability. *Invest.Ophthalmol.Vis.Sci.* 31,7:1245-1251, 1990.
- Heath, T.D., Lopez, N.G., Lewis, G.P. and Stern, W.H. Fluoropyrimidine treatment of ocular cicatricial disease. *Invest.Ophthalmol.Vis.Sci.* 27:940-945, 1986.
- Hebda, P.A. Stimulatory effects of transforming growth factor-beta and epidermal growth factor on epidermal cell outgrowth from porcine skin exlant cultures. *J.Invest.Dermatol.* 91:440, 1988.
- Heggeness, M.H., Ash, J.F. and Singer, S.J. Transmembrane linkage of fibronectin to intracellular actin-containing filaments in cultured human fibroblasts. *Ann.N.Y.Acad.Sci.* 312:414-417, 1978.
- Heichal, O., Bibi, O., Katz, J. and Cabantchik, Z.I. Nucleoside transport in mammalian cell membranes. III. Kinetic and chemical modification studies of cytosine arabinoside uridine transported hamster cells in culture. *J.Membrane.Biol.* 39:133-157, 1978.
- Heidelberger, C. Fluorinated pyrimidines. *Progr.Nucleic.Acid.Res.Mol.Biol.* 4:2-50, 1955.
- Heldin, C.H. and Westermark, B. Growth factors: mechanism of action and relation to oncogenes. *Cell*. 37:9-20, 1984.
- Herschler, J. The inhibitory factor in aqueous humour. *Vision.Res.* 21:163, 1981.
- Herschler, J., Clafin, A.J. and Fiorentino, G. The effect of aqueous humour on the growth of subconjunctival fibroblasts in tissue culture and its implications for glaucoma surgery. *Am.J.Ophthalmol.* 89:245-249, 1980.
- Heuer, D.K., Gressel, M.G. and Parrish, R.K.II. Topical fluorouracil. II. Postoperative administration in an animal model of filtration surgery. *Arch.Ophthalmol.* 104:132-136, 1986.
- Heuer, D.K., Lloyd, M.A. and Abrams, D.A. Preliminary report of a randomised clinical trial of single plate versus double plate Molteno implantation for glaucomas in aphakia and pseudophakia. In: *Glaucoma Update IV*, edited by Kriegerstein, G.K. Berlin.: Springer-Verlag., 1991, p. 244-249.
- Heuer, D.K., Parrish, R.K.II. and Gressel, M.G. 5-fluorouracil and glaucoma filtering surgery. II. A pilot study. *Ophthalmology.* 91:384-394, 1984.
- Heuer, D.K., Parrish, R.K.II., Gressel, M.G., Hodapp, E., Desjardins, D.C., Skuta, G.L., Palmberg, P.F., Nevarez, J.A. and Roackwood, E.J. 5-Fluorouracil and glaucoma filtering surgery. III. Intermediate follow-up of a pilot study. *Ophthalmology.* 93:1537-1546, 1986.

- Hial, V. and DeMello, M.C.F. Growth inhibition and morphological changes caused by indomethacin in fibroblasts in vitro. *Exp.Pathol.* 202:446-454, 1977.
- Higgs, G.A., Flower, R.J. and Vane, J.R. A new approach to anti-inflammatory drugs. *Biochem.Pharmacol.* 28:1959-1981, 1979.
- Hill, D.J., Strain, A.J., Elstow, S.F., Swenne, I.N. and Milner, R.D.G. By-functional action of transforming growth factor-beta on DNA synthesis in early passage human foetal fibroblast. *J.Cell.Physiol.* 128:322-328, 1986.
- Hirata, F., Schiffmann, E., Venkatasubramanian, K., Solomon, D. and Axelrod, J. A phospholipase A2 inhibitory protein in rabbit neutrophils induced by glucocorticoids. *Proc.Natl.Acad.Sci.USA.* 77:2533-2536, 1980.
- Hiscott, P., Waller, H.A., Grierson, I., Scott, D.L., Gregor, Z. and Morino, I. Fibronectin synthesis in subretinal membranes of proliferative vitreoretinopathy. *Br.J.Ophthalmol.* 76:486-490, 1992.
- Hitchings, R.A. and Grierson, I. Clinico pathological correlation in eyes with failed fistulizing surgery. *Trans.Ophthalmol.Soc.UK.* 103:84-88, 1983.
- Ho, P.C., Davis, W.H., Elliot, J.H. and Cohen, S. Kinetics of corneal epithelial regeneration and epidermal growth factor. *Invest.Ophthalmol.Vis.Sci.* 13:804-809, 1974.
- Hooks, J.J., Chan, C.C. and Detrick, B. Identification of the lymphokines, interferon-gamma and interleukin-2, inflammatory eye disease. *Invest.Ophthalmol.Vis.Sci.* 29:1444-1449, 1988.
- Horowitz, A.L., Hance, A.J. and Crystal, R.G. Granulocyte collagenase: selective digestion of type I relative to type III collagen. *Proc.Nat.Acad.Sci.USA.* 74:897-901, 1977.
- Horton, W.E.Jr., Higginbotham, J.D. and Chandrasekher, S. Transforming growth factor beta and fibroblasts growth factor act synergistically to inhibit collagen II synthesis through a mechanism involving regulatory DNA sequences. *J.Cell.Physiol.* 141:8-15, 1989.
- Howard, M.A., Wardwell, S. and Albert, D.M. Effect of butyrate and corticosteroids on retinoblastoma in vitro and in vivo. *Invest.Ophthalmol.Vis.Sci.* 32:1711-1713, 1991.
- Hoylaerts, M., Rijken, O.C., Lijnen, H.R. and Collen, D. Kinetics of the activation of plasminogen by human tissue plasminogen activator. *J.Biol.Chem.* 257:2912-2919, 1982.
- Humbel, R.E. Insulin-like growth factors I and II. *Eur.J.Biochem.* 190:445-462, 1990.
- Hyldahl, L. Factor VIII expression in the human embryonic eye. Differences between endothelial cells of different origin. *Ophthalmologica.* 191:184-187, 1985.
- Hynes, R.O. and Yamada, K.M. Fibronectins: Multifunctional modular glycoproteins. *J.Cell.Biol.* 95:369-377, 1982.
- Ignotz, R.A., Endo, T. and Massague, J. Regulation of fibronectin and type I collagen mRNA by transforming growth factor beta. *J.Biol.Chem.* 262:6443-6446, 1987.
- Ignotz, R.A. and Massague, J. Transforming growth factor-beta stimulates the expression of fibronectin and collagen and their incorporation into extracellular matrix. *J.Biol.Chem.* 261:4337-4340, 1986.
- Iliff, CE Surgical control of glaucoma in the Negro. *Am J Ophthalmol* 27:731-738, 1944.
- Im, M.J. and Hoopes, J.E. Energy metabolism in healing skin wounds. *J.Surg.Res.* 10:459-464, 1970.

Inaba, Z Long term results of trabeculectomy in the Japanese: an analysis by life-table method. *Jpn J Ophthalmol* 26:361-373, 1982.

Inada, K., Baba, H. and Okamura, R. Quantitative determination of human aqueous proteins by crossed immunoelectrophoresis. *Jpn.J.Ophthalmol.* 28:1-8, 1984.

Inada, K., Murata, T., Baba, H., Murata, Y. and Ozaki, M. Increase of aqueous humor proteins with aging. *Jpn.J.Ophthalmol.* 32:126-131, 1988.

Iyer, V.N. and Szybalski, W. A molecular mechanism of mitomycin action: Linking of complementary DNA strands. *Proc.Natl.Acad.Sci.U.S.A.* 50:365, 1963.

Jaccoma, E.H., Conway, B.P. and Campochiaro, P.A. Cryotherapy causes extensive breakdown of the blood-retinal barrier. *Arch.Ophthalmol.* 103:1728-1730, 1985.

Jaffe, G.J., Lewis, H., Han, D.P., Williams, G.A. and Abrams, G.W. Treatment of postvitrectomy fibrin pupillary block with tissue plasminogen activator. *Am.J.Ophthalmol.* 108:170-175, 1989.

Jampel, H.D., Leong, K.W., Dunkelburger, G.R. and Quigley, H.A. Glaucoma filtering surgery in monkeys using 5-fluorouridine in polyanhydride discs. *Arch.Ophthalmol.* 108:430-435, 1990a.

Jampel, H.D., Leong, K.W., Koya, P. and Quigley, H.A. The use of hydrophobic drugs incorporated into polyanhydrides in experimental glaucoma surgery. *Invest.Ophthalmol.Vis.Sci.(Suppl).* 31:2, 1990b.

Jampel, H.D., McGuigan, L., Pepos, J.S. and Quigley, H. Biology of experimental glaucoma filtering surgery failure. *Invest.Ophthalmol.Vis.Sci.(Suppl).* 28:378, 1987.

Jampel, H.D., McGuigan, L.J.B., Dunkelberger, G.R., L'Hernault, N.L. and Quigley, H.A. Cellular proliferation after experimental glaucoma filtration surgery. *Arch.Ophthalmol.* 106:89-94, 1988.

Jampel, H.D., Morrison, J., Vocci, M. and Quigley, H. Identification of fibrin/fibrinogen in glaucoma filtration surgery wounds. *Ophth.Surg.* 19:576-579, 1988.

Jampel, H.D., Roche, N., Stark, W.J. and Roberts, A.B. Transforming growth factor-beta in human aqueous humor. *Curr.Eye.Res.* 9:963-970, 1990.

Jay, J.L. Rational choice of therapy in primary open angle glaucoma. *Eye.* 6:243-247, 1992.

Jay, J.L. and Allan, D. The benefit of early trabeculectomy versus conventional management in primary open angle glaucoma relative to severity of disease. *Eye.* 3:528-535, 1989.

Jay, J.L. and Murray, S.B. Early trabeculectomy versus conventional management in primary open angle glaucoma. *Br.J.Ophthalmol.* 72:881-889, 1988.

Jiang, Y.O., Nagy, R.M. and Spaeth, G.L. Aqueous humour factors which influence inhibition or enhancement of mitosis. *Invest.Ophthalmol.Vis.Sci.(Suppl).* 24:86, 1983.

Jimenez, S.A., Dehm, D.J. and Prockop, D.J. Further evidence for a transport form of collagen. Its extrusion and extracellular conversion to tropocollagen in embryonic tendon. *FEBS.Letts.* 17:245-248, 1971.

Johnson, A.J. and McCarthy, W.R. The lysis of artificially induced intravascular clots in man by infusions of streptokinase. *J.Clin.Invest.* 38:1627-1643, 1959.



Johnson, R.N. and Blankenship, G. A prospective, randomized, clinical trial of heparin therapy for postoperative intraocular fibrin. *Ophthalmology*. 95:312-317, 1988.

Jones, S.C., Curtsinger, L.J., Whalen, J.D., Pietsch, J.D., Ackerman, D., Brown, G.L. and Schultz, G.S. Effect of topical recombinant TGF-beta on healing of partial thickness injuries. *J.Surg.Res.* 51:344-352, 1991.

Jones-Villeneuve, E., McBurney, M., Rogers, K. and Kalnines, V.I. Retinoic acid induces embryonal carcinoma cells to differentiate into neurons and glial cells. *J.Cell.Biol.* 94:253, 1982.

Joseph, J.P., Grierson, I. and Hitchings, R.A. Normal rabbit aqueous humour, fibronectin and fibroblast conditioned medium are chemoattractant to Tenon's capsule fibroblasts. *Eye*. 1:585-592, 1987.

Joseph, J.P., Grierson, I. and Hitchings, R.A. The effect of retinoids on the migration of Tenon's Capsule fibroblasts. *Eye*. 2:529-532, 1988.

Joseph, J.P., Grierson, I. and Hitchings, R.A. Chemotactic activity of aqueous humor. A cause of failure of trabeculectomies. *Arch.Ophthalmol.* 107:69-74, 1989a.

Joseph, J.P., Grierson, I. and Hitchings, R.A. Partial characterization of the fibroblast chemotactic constituents of human aqueous humour. *Int.Ophthalmol.* 13:125-130, 1989b.

Joseph, J.P., Grierson, I. and Hitchings, R.A. Taxol, cytochalasin B and colchicine effects on fibroblast migration and contraction: a role in glaucoma filtration surgery. *Curr.Eye.Res.* 8:203-215, 1989c.

Joyce, N.C., Matkin, E.D. and Neufeld, A.H. Corneal endothelial wound closure in vitro: Effects of EGF and indomethacin. *Invest.Ophthalmol.Vis.Sci.* 30:1548-1559, 1989.

Joyce, N.C., Meklir, B. and Neufeld, A.H. In vitro pharmacologic separation of corneal epithelial migration and spreading responses. *Invest.Ophthalmol.Vis.Sci.* 31:1816, 1990.

Kalbfleisch, J.D. and Prentice, R.L. *The statistical analysis of failure time data*, New York.:John Wiley and Sons., 1980.

Kaplan, A.P., Goetzl, E.J. and Austen, K.F. The fibrinolytic pathway of human plasma.II. The generation of chemotactic activity by activation of plasminogen proactivator. *J.Clin.Invest.* 52:2591-2595, 1973.

Kaplan, D.R., Chao, F.C., Stiles, D.C., Antoniadis, H.N. and Scher, C.D. Platelet alpha granules contain a growth factor for fibroblasts. *Blood*. 53:1043-1052, 1979.

Karppinen, V. and Myllarniemi, H. Vascular reactions in the healing laparotomy wound under cytostatic treatment. *Acta.Chir.Scand.* 136:675-680, 1970.

Katakami, C., Fujisawa, K., Sahori, A., Kazusa, R., Sakai, J., Yamamoto, M. and Aida, T. Localisation of collagen (I) and collagenase mRNAs during corneal wound healing following epikeratophakia and alkali-burn by in situ hybridisation. *Invest.Oph.Vis.Sci.(suppl)*. 31:317, 1990.

Kay, A.B., Pepper, D.S. and McKenzie, R. The identification of fibrinopeptide B as a chemotactic agent derived from human fibrinogen. *Br.J.Haematol.* 27:669-677, 1974.

Kay, J.S., Litin, B.S., Jones, M.A., Fryczkowski, A.W., Chvapil, M. and Herschler, J. Delivery of antifibroblast agents as adjuncts to filtration surgery - Part II: Delivery of 5-fluorouracil and bleomycin in a collagen implant: Pilot study in the rabbit. *Ophthalmic.Surg.* 17:796-801, 1986.

Kehrl, J.H., Wakefield, L.M., Roberts, A.B., Jakowlew, S., Alvarez-Mon, M., Derynck, R., Sporn, M.B. and Fauci, A.S. Production of transforming growth factor beta by human T lymphocytes and its potential role in the regulation of T cell growth. *J.Exp.Med.* 163:1037-1050, 1986.

Kenney, M.C., Lewis, W., Reddy, J. and Waring, G.O. Decreased fibronectin levels in aqueous humour after corneal injury. *Ophthalmic.Res.* 18:165-171, 1986.

Kenyon, K., Contente, S., Trackman, P.C., Tang, J., Kagan, H.M. and Friedman, R.M. Lysyl oxidase and rrg messenger RNA. *Science.* 253:802, 1991.

Kessel, D. Cell surface alterations associated with exposure of leukaemia L1210 cells to fluorouracil. *Cancer.Res.* 40:322-324, 1980.

Ketchel, M.M., Favour, C.B. and Strugis, S.H. The in vitro action on leukocyte migration. *J.Exp.Med.* 107:211-218, 1958.

Kim, R.Y. and Stern, W.H. Retinoids and butyrate modulate fibroblast growth and contraction of collagen matrices. *Invest.Ophthalmol.Vis.Sci.* 31:1183-1186, 1990.

Kitazawa, T., Kinoshita, S., Fujita, K., Araki, K., Watanabe, H., Ohashi, Y. and Manabe, R. The mechanism of accelerated corneal epithelial healing by human epidermal growth factor. *Invest.Ophth.Vis.Sci.* 31:1773-1778, 1990.

Kittlick, P.D. Fibrin in fibroblast cultures-a metabolic study as a contribution to inflammation and tissue repair. *Exp.Path.* 17:312-326, 1979.

Kleinman, H.K., Klebe, R.J. and Martin, G.R. Role of collagenous matrices in the adhesion and growth of cells. *J.Cell Biol.* 88:473-485, 1981.

Knighton, D.R., Hunt, T.K., Thakral, K.K. and Goodson, W.H. Role of platelets and fibrin in the healing sequence: An in vivo study of angiogenesis and collagen synthesis. *Ann.Surg.* 196:379-388, 1982.

Knisely, T.L. and Granstein, R.D. Analysis of inhibitory factors produced by iris/ciliary body cells in vitro. *Invest.Ophthalmol.Vis.Sci.* 31:241, 1990.

Knox, P., Crooks, S. and Rimmer, C.S. Role of fibronectin in the migration of fibroblasts into plasma clots. *J.Cell Biol.* 102:2318-2323, 1986.

Koerner, F., Merz, A., Gloor, B. and Wagner, E. Postoperative retinal fibrosis- a controlled clinical study of systemic steroid therapy. *Graefe's.Arch.Clin.Exp.Ophthalmol.* 219:268-271, 1982.

Kohno, T., Sorgente, N., Goodnight, R. and Ryan, S. Alterations in the distribution of fibronectin and laminin in the diabetic human eye. *Invest.Ophthalmol.Vis.Sci.* 28:515-521, 1987.

Kondo, M. and Araie, M. Concentration change of fluorouracil in the external segment of the eye after subconjunctival injection. *Arch.Ophthalmol.* 106:1718-1721, 1988.

Kornblueth, W. and Tenenbaum, E. The inhibitory effect of aqueous humour on the growth of cells in tissue culture. *Am.J.Ophthalmol.* 42:70-74, 1956.

Kosow, D.P. Kinetic mechanism of activation of human plasminogen by streptokinase. *Biochemistry.* 14:4459-4465, 1975.

Kronfeld, P.C. The chemical demonstration of transconjunctival passage of aqueous after antiglaucomatous operations. *Am.J.Ophthalmol.* 35:38-45, 1952.

- Kruh, J. Effects of sodium butyrate, a new pharmacological agent, on cells in culture. *Mol.Cell.Biochem.* 42:65-82, 1982.
- Kruse, F.E. and Tseng, S.C.G. A serum free clonal growth assay for limbal peripheral, and central corneal epithelium. *Invest.Ophthalmol.Vis.Sci.* 32:2086-2095, 1991.
- Kulkarni, P.S., Bhattacharjee, P., Eakins, K.E. and Srinivasan, B.D. Anti-inflammatory effects of betamethasone phosphate, dexamethasone phosphate and indomethacin on rabbit ocular inflammation induced by bovine serum albumin. *Curr.Eye.Res.* 1:43-47, 1981.
- Kulkarni, P.S. and Eakins, K.E. N-0164 inhibits generation of thromboxane A<sub>2</sub>-like activity from prostaglandin endoperoxides by human platelet microsomes. *Prostaglandins.* 12:465, 1976.
- Kulkarni, P.S. and Srinivasan, B.D. Steroidal and non steroidal anti-inflammatory drugs in ocular inflammation. *Ocul.Inflam.* 1:11-18, 1983.
- Kurkinen, M., Vaeheri, A., Roberts, P.J. and Stenman, S. Sequential appearance of fibronectin and collagen in experimental granulation tissue. *Lab.Invest.* 43:47-51, 1980.
- Kwaan, H.C. and Astrup, T. Tissue repair in the presence of locally applied inhibitors of fibrinolysis. *Exp.Mol.Path.* 11:82-88, 1969.
- Kwong, E.M., Litin, B.S., Jones, M.A. and Herschler, J. Effect of antineoplastic drugs on fibroblast proliferation in rabbit aqueous humour. *Ophthalmic.Surg.* 15:847-851, 1984.
- Kyritsis, A., Joseph, G. and Chader, G.J. Effects of butyrate, retinol, and retinoic acid on human Y-79 retinoblastoma cells growing in monolayer cultures. *J.Natl.Cancer.Inst.* 73:649-654, 1984.
- Kyritsis, A.P., Tsokos, M. and Chader, G.J. Control of retinoblastoma cell growth by differentiating agents: current work and future directions. *Anticancer.Res.* 6:465-473, 1986.
- Laato, M., Niinikoski, J., Lebel, L. and Gerdin, B. Stimulation of wound healing by epidermal growth factor. *Ann.Surg.* 203:379-381, 1986.
- Lahav, J., Lawler, J. and Grimbrone, M.A. Thrombospondin interactions with fibronectin and fibrinogen. *Eur.J.Biochem.* 145:151-156, 1984.
- Landshman, N., Belkin, M., Ben-Hanan, I., Ben-Chaim, O., Assia, E. and Savion, N. Regeneration of cat corneal endothelium induced in vivo by fibroblast growth factor. *Exp.Eye.Res.* 45:805, 1987.
- Langdon, S.P., Hawkes, M.M., Hay, F.G., Lawrie, S.S., Schol, D.J., Hilgers, J., Leonard, R.C. and Smyth, J.F. Effect of sodium butyrate and other differentiation inducers on poorly differentiated human ovarian adenocarcinoma cell lines. *Cancer.Res.* 48:6161-6165, 1988.
- Laval, J. and Coles, R. Role of cortisone in glaucoma surgery. *Arch.Ophthalmol.* 49:168-181, 1953.
- Lavin, M.J., Wormald, R.P.L., Migdal, C.S. and Hitchings, R.A. The influence of prior therapy on the success of trabeculectomy. *Arch.Ophthalmol.* 108:1543-1548, 1990.
- Lawrence, W.T., Norton, J.A. and Sporn, M.B. The effect of chemoattractants and growth factors on wound healing in a wound chamber model in adriamycin treated rats. *Ann.Surg.* 203:142-147, 1986a.

Lawrence, W.T., Norton, J.A., Sporn, M.B., Gorschboth, C. and Grotendorst, G.R. The reversal of an adriamycin induced healing impairment with chemoattractants and growth factors. *Ann.Surg.* 203:142-147, 1986b.

Lee, D.A., Flores, R.A., Anderson, P.J., Leong, K.W., Teekhasaenee, C., De Kater, A.W. and Hertzmark, E. Glaucoma filtration surgery in rabbits using bioerodible polymers and 5-fluorouracil. *Ophthalmology.* 94:1523-1530, 1987.

Lee, D.A., Lee, T.C., Cortes, A.E. and Kitada, S. Effects of mithramycin, mitomycin, daunorubicin and bleomycin on human subconjunctival fibroblast attachment and proliferation. *Invest.Ophthalmol.Vis.Sci.* 31:2136-2144, 1990.

Lee, D.A., Leong, K.W., Panek, W.C., Eng, C.T. and Glasgow, B.J. The use of bioerodible polymers and 5-fluorouracil in glaucoma filtration surgery. *Invest.Ophthalmol.Vis.Sci.* 29:1692-1697, 1988.

Lee, D.A., Shapourifar-Tehrani, S., Stephenson, T.R. and Kitada, S. The effects of the fluorinated pyrimidines FUR, FUdR, FUMP, and FdUMP on human tenon's fibroblasts. *Invest.Ophth.Vis.Sci.* 32:2599-2609, 1991.

Lee, L-S. and Weinstein, I.B. Epidermal growth factor, like phorbol esters, induces plasminogen activator in HeLa cells. *Nature.(Lond).* 274:696-697, 1978.

Leet, D.M. Treatment of total hyphemas with urokinase. *Am.J.Ophthalmol.* 84:79-84, 1977.

Lehmann, E.L. *Nonparametrics: Statistical methods based on ranks*, San Francisco, CA.:Holden-Day., 1975.

Leibovich, S.J. and Ross, R. The role of the macrophage in wound repair. *Am.J.Pathol.* 84:71-100, 1975.

Leibovitch, M.P., Leibovitch, S.A., Harel, J. and Kruh, J. Effect of sodium butyrate on messenger RNA populations in myogenic cells in culture. *Differentiation.* 22:106-112, 1982.

Lemor, M., de Bustros, S. and Glaser, B.M. Low dose colchicine inhibits astrocyte, fibroblast, and retinal pigment epithelial cell migration and proliferation. *Arch.Ophthalmol.* 104:1223-1225, 1986.

Lerman, M.I. and Benyumovitch, M.S. Effect of mitomycin-C on protein synthesis in human neoplastic cell lines. *Nature.* 206:1231, 1965.

Leschey, K.H., Hines, J., Singer, J.H., Hackett, S.F. and Campochiaro, P.A. Inhibition of growth factor effects in retinal pigment epithelial cells. *Invest.Ophthalmol.Vis.Sci.* 32:1770-1778, 1991.

Leske, M.C. The epidemiology of open-angle glaucoma. *Am.J.Epidemiol.* 118:166-191, 1983.

Lichter, P.R., Becker, M.H. and Janz, N.K. The case for quality of life assessment in glaucoma clinical trials. In: *Glaucoma Update IV*, edited by Krieglstein, G.K. Berlin: Krieglstein, G.K., 1991, p. 187-192.

Liddle, G.W. Clinical pharmacology of the anti-inflammatory agents. *Clin.Pharmacol.Ther.* 2:615-635, 1961.

Lijnen, H.R., Zamarron, C. and Collen, D. Prourokinase: Kinetics and mechanism of action. *Thromb.Haemost.(abst).* 118, 1985.

Lin, S.L., Kikuchi, T. and Pledger, W.J. Interferon inhibits the establishment of competence in G0/S phase transition. *Science.* 233:356-359, 1986.

Liu, J-M. and Davidson, J.M. The elastogenic effect of recombinant transforming growth factor beta on poor sign realtic smooth muscle cells. *Biochem.Biophys.Res.Comm.* 154:895-901, 1988.

Lofffield, K. and Ball, S.F. 5-fluorouracil (5-FU) in primary trabeculectomy: A randomised trial. *Invest.Ophthalmol.Vis.Sci.(Suppl).* 32:745, 1991.

Long, D.A. The influence of corticosteroids on immunological responses to bacterial infection. *Int.Arch.Allergy Appl.Immunol.* 10:5-12, 1957.

Longstaff, S., Wormald, R.P.L., Mazover, A. and Hitchings, R.A. Glaucoma Triple Procedures: efficacy of intraocular pressure control and visual outcome. *Ophthalmic.Surg.* 21:786-793, 1990.

Lotan, R. Effects of vitamin A and its and analogs (retinoids) on normal and neoplastic cells. *Biochimica.et.Biophysica.Acta.* 605:33-91, 1980.

Low, S.Q., Kitada, S. and Lee, D.A. Interferon-gamma inhibits collagen synthesis by human tenon's capsule fibroblasts in vitro. *Invest.Ophthalmol.Vis.Sci.* 32:2964-2969, 1991.

Lown, J.W. and Begleiter, A.J. Studies related to anti-tumour antibiotics. V. Reactions of mitomycin-c with DNA examined by ethidium fluorescence. *Can.J.Biochem.* 54:110, 1976.

Lyons, R.M., Keski-Oja, J. and Moses, H.L. Proteolytic activation of latent tranforming growth factor-Beta from fibroblast conditioned medium. *J.Cell.Biol.* 106:1659-1664, 1988.

Machemer, R. Massive perietinal proliferation: A logical approach to therapy. *Trans.Am.Ophthalmol.Soc.* 75:556-586, 1977.

Madoc-Jones, H. and Bruce, W.R. On the mechanism of the lethal action of 5-fluorouracil on mouse L cells. *Cancer.Res.* 28:1976-1981, 1968.

Madri, J.A., Pratt, B.M. and Tucker, A. Phenotypic modulation of endothelial cells by transforming growth factor beta depends upon the composition and organisation of the extracellular matrix. *J.Cell.Biol.* 106:1375-1384, 1988.

Majno, G., Gilmore, V. and Leventhal, M. On the mechanism of vascular caused by histamine-type mediators. *Circ.Res.* 21:833-847, 1967.

Makino, F. and Ocada, S. Comparative studies of the effects of carcinogenic and anti tumour agents on the DNA replication of cultured mammalian cells. *Mutat.Res.* 23:387, 1974.

Martinet, Y., Bitterman, P.B. and Mormex, J.F. Activated human monocytes express the c-sis protooncogene and release a mediator showing PDGF -like activity. *Nature.* 319:158-160, 1986.

Marz, R., Wohlhueter, R.M. and Plagemann, P.G.W. Purine and pyrimidine transport and phosphoribosylation and their interaction in overall optic by cultured mammlion cells. *J.Biol.Chem* 254:2329-2338, 1979.

Massague, J. The transforming growth factor-beta family. *Annu.Rev.Cell Biol.* 6:597-641, 1990.

Massague, J., Heino, J. and Laiho, M. Mechanisms in TGF-Beta action. In: *Clinical applications of TGF-Beta*, edited by Bock.G.R., and Marsh, J. Chichester: A Wiley-Interscience Publication, 1991, p. 51-65.

Mathers, W.D., Sherman, M., Fryczkowski, A. and Jester, J.V. Dose-dependant effects of epidermal growth factor on corneal wound healing. *Invest.Ophthalmol.Vis.Sci.* 30:2403-2406, 1989.

Maybaum, J., Ullman, B., Mandel, H.G., Day, J.L. and Sadee, W. Regulation of RNA- and DNA-directed actions of 5-fluoropyrimidines in mouse T-lymphoma (s-49) cells. *Cancer.Res.* 40:4209-4215, 1980.

Maynard, J.R., Hechman, C.A., Pitick, F.A. and Nemerson, Y. Association of tissue factor activity with the surface of cultured cells. *J.Clin.Invest.* 55:814-824, 1975.

McAuslan, B.R., Bender, V., Reilly, W. and Moss, B.A. New functions of epidermal growth factor: stimulation of capillary endothelial cell migration and matrix dependent proliferation. *Cell.Biol.Int.Rep.* 9:175-179, 1985.

McCarthy, J.B., Sas, D.F. and Furcht, L.T. Mechanisms of parenchymal cell migration into wounds. In: *The molecular and cellular biology of wound repair*, edited by Clark, R.A.F. and Henson, P.M. New York: Plenum Press, 1988, p. 281-319.

McDonald, J.A. Fibronectin; A primitive matrix. In: *The molecular and cellular biology of wound repair*, edited by Clark, R.A.F. and Henson, P.M. New York: Plenum Press, 1988, p. 405-435.

McDonald, J.A., Kelley, D.G. and Broekelmann, T.J. Role of fibronectin in collagen deposition. Fab1 antibodies to the gelatin-binding domain of fibronectin inhibits both fibronectin and collagen organization in fibroblast extracellular matrix. *J.Cell.Biol.* 92:485-492, 1982.

McGuigan, L.J.B., Cook, D.J. and Yablonski, M.E. Dexamethasone, D-penicillamine, and glaucoma filtering surgery in rabbits. *Invest.Ophthalmol.Vis.Sci.* 27:1755, 1986.

McGuigan, L.J.B., Mason, R.P., Sanchez, R. and Quigley, H.A. D-penicillamine and beta-aminopropionitrile effects on experimental filtering surgery. *Invest.Ophthalmol.Vis.Sci.* 28:1625-1629, 1987.

Medawar, P.B. Immunity to homologous grafted skin.III. The fate of skin homografts transplanted to the brain, to subcutaneous tissue, and to the anterior chamber of the eye. *Br.J.Exp.Pathol.* 29:58-64, 1984.

Mensing, H., Ponte, B.P., Muller, D.K. and Gauss-Muller, V. A study on fibroblast chemotaxis using fibronectin and conditioned medium as chemoattractants. *Eur.J.Cell Biol.* 29:268-273, 1983.

Merritt, J.C. Filtering procedures in American blacks. *Ophthalmic Surg* 11:91-94, 1980.

Migdal, C. and Hitchings, R. The developing bleb: Effect of topical antiprostaglandins on the outcome of glaucoma fistulizing surgery. *Br.J.Ophthalmol.* 67:655-660, 1983.

Migdal, C., Hitchings, R.A. and Gregory, W. Primary treatment trial analysis of visual fields. *Eye.* 114:737-741, 1993.(In Press)

Miller, R.D., and Barber, J.C. Trabeculectomy in black patients. *Ophthalmic Surg* 12:46-50, 1981.

Miller, M.H., Grierson, I., Unger, W.I. and Hitchings, R.A. Wound healing in an animal model of glaucoma fistulizing surgery in the rabbit. *Ophthalmic.Surg.* 20:350-357, 1989.

Miller, M.H., Grierson, I., Unger, W.G. and Hitchings, R.A. The effect of topical dexamethasone and preoperative beta irradiation on a model of glaucoma fistulizing surgery in the rabbit. *Ophthalmic.Surg.* 21:44-54, 1990.

- Miller, M.H. and Rice, N.S.C. Trabeculectomy combined with beta irradiation in congenital glaucoma: A beneficial treatment. *Invest.Ophthalmol.Vis.Sci.(Suppl)*. 32:746, 1991.
- Milliken, G.A. and Johnson, D.E. *Analysis of Messy Data. Volume 1: Designed Experiments*, New York.:Van Nostran Reinhold., 1984.
- Minckler, D.S., Shamma, A., Wilcox, M. and Ogden, T.E. Experimental studies of aqueous filtration using the Molteno implant. *Trans.Am.Ophthalmol.Soc.* 85:368-392, 1987.
- Miyake, K., Asakura, M. and Maekubo, K. Consensual reactions of human blood aqueous barrier to implant operations. *Arch.Ophthalmol.* 102:558-561, 1984.
- Mizel, S.B. The interleukins. *FASEB.J.* 3:2379-2388, 1989.
- Molteno, A.C.B., Straughan, J.L. and Ancker, E. Control of bleb fibrosis after glaucoma surgery by anti-inflammatory agents. *S.Afr.Med.J.* 50:881-885, 1976.
- Moncada, S., Bunting, S., Mullane, K., Thorogood, P. and Vane, J.R. Imidazole: A selective potent antagonist of thromboxane synthetase. *Prostaglandins.* 13:611-618, 1977.
- Moncada, S., Needleman, P., Bunting, S. and Vane, J.R. Prostaglandin endoperoxide and thromboxane generating system and their selective inhibition. *Prostaglandins.* 12:323-329, 1976.
- Montandon, D., Gabbiani, G., Ryan, G.B. and Majno, G. The contractile fibroblast. Its relevance in plastic surgery. *Plast.Reconstr.Surg.* 52:286-292, 1973.
- Moore, H.W. Bio-activation as a model for drug design. Bioreductive alkylation. *Science.* 197:527, 1977.
- Moorhead, L.C. Inhibition of collagen cross-linking: a new approach to ocular scarring. *Curr.Eye.Res.* 1:77, 1981.
- Moorhead, L.C., Smith, J., Stewart, R. and Kinbrough, R. Effects of beta-aminopropionitrile after glaucoma filtration surgery: Pilot human trial. *Ann.Ophthalmol.* 19:223-225, 1987.
- Morales, T.I. and Roberts, A.B. Transforming growth factor beta regulates the metabolism of proteoglycans in bovine cartilage organ cultures. *J.Biol.Chem.* 263:12828-12831, 1988.
- Morgan, C.J. and Pledger, W.J. Fibroblast proliferation. In: *Wound healing biochemical and clinical aspects*, edited by Cohen, I.K., Diegelmann, R.F. and Lindblad, W.J. Philadelphia: W B Saunders and Co., 1992, p. 63-76.
- Moses, H.L., Yang, E.Y. and Pietenpol, J.A. Regulation of epithelial proliferation by TGF-beta. In: *Clinical Applications of TGF-beta*, edited by Bock, G.R. and Marsh, J. Chichester: A Wiley-Interscience Publication, 1990, p. 66-80.
- Mullen, B.M., Mattox, D.E., Von Hoff, D.D. and Hearne, E.M. The effects of preoperative adriamycin and dihydroxyathracenedione on wound healing. *Laryngoscope.* 91:1436-1443, 1981.
- Munro, T.R. The relative radio sensitivity of the nucleus and cytoplasm of the chinese hamster fibroblasts. *Radiat.Res.* 42:451-470, 1970.
- Murray, P.I., Hoekzema, R., van Haren, M.A.C., de Hon, F.D. and Kijlstra, A. Aqueous humor interleukin-6 levels in uveitis. *Invest.Ophthalmol.Vis.Sci.* 31:917-920, 1990.

Myllarniemi, H. and Petokallio, P. The effect of high dose cyclophosphamide therapy in the abdominal cavity of the rat: Adhesions and their vascular patterns. *Ann.Chir.Gynecol.* 63:238-245, 1974.

Nakagawa, S., Yoshida, S., Hirao, Y., Kasuga, S. and Fuwa, T. Biological effects of biosynthetic human EGF on the growth of mammalian cells in vitro. *Differentiation.* 29:284-288, 1985.

Nathan, C.F. Secretory products of macrophages. *J.Clin.Invest.* 79:319-326, 1987.

Nayak, S.K. and Binder, P.S. The growth of endothelium from human corneal rims in tissue culture. *Invest.Ophthalmol.Vis.Sci.* 25:1214, 1984.

Nayak, S.K., Samples, J.R., Deg, J.K. and Binder, P.S. Growth characteristics of primate (baboon) corneal endothelium in vitro. *Invest.Ophthalmol.Vis.Sci.* 27:607, 1986.

Nelson, R.D., McCormack, R.T. and Fiegel, V.D. Chemotaxis of human leukocytes under agarose. In: *Leukocyte Chemotaxis*, edited by Gallin, J.I. and Quie, P.C. New York: Raven, 1978, p. 25-42.

Neupert, G. and Muller, P. Growth inhibition and morphological changes caused by indomethacin in fibroblasts in vitro. *Exp.Pathol.* 11:1-5, 1975.

Nickoloff, B.J., Mitra, R.S., Riser, B.L., Dixit, V.M. and Varani, J. Modulation of keratinocyte motility: Correlation with production of extracellular matrix molecules in response to growth promoting and antiproliferative factors. *Am.J.Pathol.* 132:543-551, 1988.

Nishida, T., Nakagawa, S., Awata, T., Ohashi, Y., Watanabe, K. and Manabe, R. Fibronectin promotes epithelial migration of cultured rabbit cornea in situ. *J.Cell Biol.* 97:1653-1657, 1983.

Nishida, T., Nakamura, M., Mishima, H. and Otori, T. Differential modes of action of fibronectin and epidermal growth factor on rabbit corneal epithelial migration. *J.Cell.Physiol.* 145:549-554, 1990.

Noda, M., Yoon, K., Prince, C.W., Butler, W.T. and Rodan, G.A. Transcriptional regulation of osteopontin production in rat osteosarcoma cells by type beta transforming growth factor beta. *J.Biol.Chem.* 263:13916-13921, 1988.

Nordlund, J.R., Pasquale, L.R., Quigley, H.A. and Jampel, H.D. Effectiveness of intraoperative 5-fluorouracil versus intraoperative mitomycin-c in experimental rabbit glaucoma surgery. *Invest.Ophthalmol.Vis.Sci.* 33/4:1393, 1992.(Abstract)

Norris, D.A., Clark, R.A.F., Swigart, L.M., Huff, J.C., Weston, W.L. and Howell, S.E. Fibronectin fragments are chemotactic for human peripheral blood monocytes. *J.Immunol.* 129:1612-1618, 1982.

Nozu, K. Flurbiprofen, a highly potent inhibitor of prostaglandin synthesis. *Biochim.Biophys.Acta.* 529:493-496, 1978.

Obberghen-Schilling, E.V., Roche, N.S., Flanders, K.C., Sporn, M.B. and Roberts, A.B. Transforming growth factor beta 1 positively regulates its own expression in normal and transformed cells. *J.Biol.Chem.* 263:7741-7746, 1988.

Ohashi, Y., Motakura, M., Kinoshita, Y. and Mano, T. Presence of epidermal growth factor in human aqueous tears. *Invest.Ophthalmol.Vis.Sci.* 30:1879-1885, 1989.

Old, L.J. Tumour necrosis factor (TNF). *Science.* 230:630-632, 1985.



- Olwin, B.B. and Hauschka, S.D. Cell type and tissue distribution of the fibroblast growth factor receptor. *J.Cell.Biochem.* 39:443-454, 1989.
- Ortiz, J.R., Walker, S.D., McManus, P.E., Martinez, L.A., Brown, R.H. and Jaffe, G.J. Filtering bleb thrombolysis with tissue plasminogen activator. *Am.J.Ophthalmol.* 106:624, 1988.
- Palmer, R.M.T., Stepney, R., Higgs, G.A. and Eakins, K.E. Chemotactic activity of arachidonic acid lipoxygenase products on leukocytes from different species. *Prostaglandins.* 20:411-418, 1980.
- Parelman, J.J., Nicolson, M. and Pepose, J.S. Epidermal growth factor in human aqueous humor. *Am.J.Ophthalmol.* 109:603-604, 1990.
- Parker, C.W. Leukotrienes: their metabolism, structure and role in allergic response. In *Leukotrienes and other lipoxygenase products.* Raven Press 9:115, 1982.
- Parker, W. and Bearn, A. Studies on the transferrins of adult serum, cord serum, and cerebrospinal fluid. *J.Exp.Med.* 115:83-105, 1962.
- Peacock, E. *Wound repair*, Philadelphia.:Saunders, 1984. pp. 102-140.
- Peacock, E.E. Pharmacological control of surface scarring in human beings. *Ann.Surg.* 193:592-579, 1981.
- Peacock, E.E. and Madden, J.W. Some studies in the effects of beta-aminopropionitrile in patients with injured flexor tendons. *Surgery.* 66:215-223, 1969.
- Pearson, C.H., Pearson, D., Hibahara, S., Hofsteenge, J. and Chiquet-Ehrismann, R. Tenascin-cDNA cloning an induction TGF-beta. *EMBO.J.* 7:2677-2681, 1988.
- Peiffer, R.L., Lipper, S., Merritt, J.C., Wright, W. and Jones, B. Myofibroblasts in the healing of filtering wounds in rabbit, dog and cat. *Glaucoma.* 3(5):277-280, 1981.
- Penttinen, R.P., Kobayashi, S. and Bornstein, P. Transforming growth factor beta increases mRNA for matrix proteins both in the presence and in the absence of changes in mRNA stability. *Proc.Natl.Acad.Sci.USA.* 85:1105-1108, 1988.
- Perdue, J.F., Lubenskyi, W., Kivity, E., Sonder, S.A. and Fenton, J.W.II. Protease mitogenic response of chick embryo fibroblasts and receptor binding processing of alpha thrombin. *J.Biol.Chem.* 256:2767-2776, 1981.
- Petroutsos, G., Courty, J., Guimaraes, R., Pouliquen, Y., Barritault, D., Plouet, J. and Courtois, Y. Comparison of the effects of EGF, pFGF and EDGF on corneal epithelial wound healing. *Curr.Eye.Res.* 3:593-598, 1984.
- Petroutsos, G., Sebag, J. and Courtois, Y. Epidermal growth factor increases tensile strength during wound healing. *Ophthalmic.Res.* 18:299, 1986.
- Plagemann, P.G.W., Marz, R. and Wohlhueter, R.M. Transport and metabolism of deoxycytidine and I-beta-D-arabinofuranosylcytosine into cultured Novikoff rat hepatoma cells, relationship to phosphorylation, and regulation of triphosphate synthesis. *Cancer.Res.* 38:978-989, 1978.
- Pledger, W.J., Stiles, C.D., Antoniades, H.N. and Scher, C.D. Induction of DNA synthesis in BALB/c3T3 cells by serum components. Re-evaluation of the commitment process. *Proc.Natl.Acad.Sci.USA.* 74:4481-4485, 1977.
- Plouet, J.T. and Gospodarowicz, D. Iris derived melanocytes contain a growth factor that resembles basic fibroblast growth factor. *Exp.Eye.Res.* 1990.

Polansky, J.R., Wood, I.S., Maglio, M.T. and Alvarado, J.A. Trabecular meshwork cell culture in glaucoma research: Evaluation of biological activity and structural properties of human trabecular meshwork cells in vitro. *Ophthalmology*. 91:580, 1984.

Polverini, P.J., Cotran, R.S., Gimbrone, M.A.Jr. and Unanue, E.R. Activated macrophages induce vascular proliferation. *Nature*. 269:804-806, 1977.

Postlethwaite, A.E. and Kang, A.H. Characterization of guinea pig lymphocyte-derived chemotactic factor for fibroblasts. *J.Immunol*. 124:1426-1466, 1980.

Postlethwaite, A.E., Keski-Oja, J., Balian, G. and Kang, A.H. Induction of fibroblast chemotaxis by fibronectin. Localization of the chemotactic region to a 140,000 molecular weight. *J.Exp.Med*. 153:494-499, 1981.

Postlethwaite, A.E., Keski-Oja, J., Moses, H.L. and Kang, A.H. Stimulation of the chemotactic migration of human fibroblasts by transforming growth factor beta. *J.Exp.Med*. 165:251-256, 1987.

Postlethwaite, A.E., Seyer, J.M. and Kang, A.H. Chemotactic attraction of human fibroblasts to type I-II-III collagens and collagen-derived peptides. *Proc.Natl.Acad.Sci.USA*. 75:871-875, 1978.

Postlethwaite, A.E., Snyderman, R. and Kang, A.H. The chemotactic attraction of human fibroblast to a lymphocyte derived factor. *J.Exp.Med*. 144:1188-1203, 1976.

Postlethwaite, A.E., Snyderman, R.K. and Kang, A.H. Generation of a fibroblast chemotactic factor in serum by activation of complement. *J.Clin.Invest*. 64:1379-1385, 1979.

Postlethwaite, A.E., Snyderman, R. and Kang, A.H. Generation of a fibroblast chemotactic in serum by activation of complement lymphocyte-derived factor. *J.Clin.Invest*. 64:1379-1385, 1979.

Prasad, K.N. and Sinha, P.K. Effect of sodium butyrate on mammalian cells in culture: A review. *In vitro*. 12:125-132, 1976.

Priestley, G.C. Effect of corticosteroids on the growth and metabolism of fibroblasts culture from human skin. *Br.J.Dermatol*. 99:253-261, 1978.

Prockop, D.J., Keinstein, E. and Mulveny, T. Hydroxylation of lysin in a polypeptide precursor of collagen. *Biochem.Biophys.Res.Comm*. 22:124-128, 1966.

Radius, R.L., Herschler, J., Claflin, A.J. and Fiorentino, G. Aqueous humour changes after experimental filtering surgery. *Am.J.Ophthalmol*. 89:250-254, 1980.

Raghow, R., postlethwaite, A., Keski-Oja, J., Moses, H. and Kang, A. Transforming growth factor beta increases steady state levels of type I procollagen and fibronectin messenger RNAs post transcriptionally in cultured human dermal fibroblasts. *J.Clin.Invest*. 79:1285-1288, 1987.

Raymond, G., Jumblatt, M., Bartels, S. and Neufeld, A. Rabbit corneal endothelial cells in vitro. Effects of EGF. *Invest.Ophthalmol.Vis.Sci*. 27:474-482, 1986.

Reddan, J., Weinsieder, A. and Wilson, D. Aqueous humour from traumatised eyes triggers cell division in the epithelia of cultured cells. *Exp.Eye.Res*. 28:267-276, 1979.

Reddan, J.R. and Wilson-Dziedzic, D. Insulin-like growth factor and epidermal growth factor trigger mitosis in lenses cultured in a serum-free medium. *Invest.Ophthalmol.Vis.Sci*. 24:409-416, 1983.

- Regan, E.F. Scleral cautery with iridectomy-an experimental study. *Trans.Am.Ophthalmol.Soc.* 61:219-231, 1963.
- Reid, T., Kenney, M.C. and Waring, G.O. Isolation and characterization of fibronectin from bovine aqueous humor. *Invest.Ophthalmol.Vis.Sci.* 22:57-61, 1982.
- Ren, J.M., Wei, H.R., Zeng, S.Q., Li, J.P. and Hu, C.Z. Doxorubicin inhibition of subconjunctival fibroblast proliferation and its pharmacokinetics in rabbit eyes. *glaucom* 11:152-157, 1989.
- Repush, L.A., Fitzgerald, T.J. and Furcht, L.T. Fibronectin involvement in granulation tissue and wound healing in rabbits. *J.Histochem.Cytochem.* 30:351-358, 1982.
- Rhoeds, R.E. and Udenfriend, S. Purification and properties of proline hydroxylase from new-born rat skin. *Arch.Biochem.Biophys.* 139:329-339, 1970.
- Rich, L.F., Weimar, V.L., Squires, E.L. and Haraguchi, K.H. Stimulation of corneal wound healing with mesodermal growth factor. *Arch.Ophthalmol.* 97:1326-1330, 1979.
- Rich, M.A., Saslaw, L. and Eidinoff, M.L. Some differences among various mammalian cell lines in reversal of growth inhibition by 5-fluorouracil. *Proc.Soc.Exp.Biol.Med.* 103:791-796, 1960.
- Riggs, M.G., Whittaker, R.G., Neumann, J.R. and Ingram, V.M. n-Butyrate causes histone modification in HeLa and Friend erythroleukaemia cells. *Nature* 268:462-464, 1977.
- Rijken, O.C., Hoylaerts, M. and Collen, D. Fibronolytic properties of one chain and two chain extrinsic (tissue type) plasminogen activator. *J.Biol.Chem.* 257:2920-2925, 1982.
- Robbins, S., Cotran, R. and Kumar, V. *Pathologic Basis of Disease*, Philadelphia:Saunders,W.B., 1984. Ed. 3rd
- Roberts, A.B., Anzano, M.A., Lamb, L.C., Smith, J.M. and Sporn, M.B. Type beta transforming growth factor: A bifunctional regulator of cellular growth. *Proc.Natl.Acad.Sci.USA.* 82:119-123, 1985a.
- Roberts, A.B., Anzano, M.A., Wakefield, L.A., Roche, N.S., Stern, D.F. and Sporn, M.B. Type beta transforming growth factor: A bifunctional regulator of cellular growth. *Proc.Natl.Acad.Sci.USA.* 82:119-123, 1985b.
- Roberts, A.B., Sporn, M.B., Assoian, R.K., Smith, J.M., Roche, N.S., Wakefield, L.M., Heine, U.I., Liotta, L.A., Falanga, V., Kehrl, J.H. and Fauci, A.S. Transforming growth factor type beta: Rapid induction of fibrosis and angiogenesis in vivo and stimulation of collagen formation in vitro. *Proc.Natl.Acad.Sci.USA.* 83:4167-4171, 1986.
- Roberts, A.B. and Sporn, M.B. The transforming growth factor-betas. In: , edited by Roberts, A.B. and Sporn, M.B. 1993,
- Roberts, J.J., Brent, T.P. and Crathorn, A.R. Evidence for the inactivation and repair of the mammalian DNA template after alkylation by half mustard gas. *Eur.J.Cancer.* 7:545, 1971.
- Rockwood, E.J., Parrish, R.K.II., Heuer, D.K., Skuta, G.L., Hodapp, E., Palmberg, P.F., Gressel, M.G. and Feuer, W. Glaucoma filtering surgery with 5-fluorouracil. *Ophthalmology.* 94:1071-1078, 1987.
- Rootman, J., Ostry, A. and Gudauskas, G. Pharmacokinetics and metabolism of 5FU following subconjunctival versus intravenous administration. *Can.J.Ophthalmol.* 19:187-191, 1984.
- Rootman, J., Tisdall, J., Gudauskas, G. and Ostry, A. Intraocular penetration of subconjunctivally administered 14C-fluorouracil in rabbits. *Arch.Ophthalmol.* 97:2375-2378, 1979.

- Ross, R. The fibroblast and wound repair. *Biol.Rev.* 43:51-96, 1968.
- Ross, R. The pathogenesis of atherosclerosis-an update. *New.Eng.J.Med.* 314:488-500, 1986.
- Ross, R. Platelet-Derived Growth Factor. *Lancet.* 8648:1179-1181, 1989.
- Ross, R., Glomset, J., Kariya, B. and Harker, L. A platelet dependent serum factor that stimulates the proliferation of arterial smooth muscle cells in vitro. *Proc.Natl.Acad.Sci.USA* 71:1207-1210, 1974.
- Ross, R. and Odland, G. Human wound repair. II. Inflammatory cells , epithelial mesenchymal interrelations and fibrogenesis. *J.Cell.Biol.* 39:152-168, 1968.
- Ross, R., Raines, E.W. and Bowen-Pope, D.F. The biology of platelet derived growth factor. *Cell.* 46:155-169, 1986.
- Rossi, P., Carsenty, G., Roberts, A.B., Roche, N.S., Sporn, M.B. and de Crombrughe, B. A nuclear factor 1 binding site mediates the transcriptional activation of a type I collagen promoter by transforming growth factor beta. *Cell.* 52:405-444, 1988.
- Rozengurt, E., Stein, W.D. and Wigglesworth, N.M. Uptake on necleosides in density-inhibited cultures of 3T3 cells. *Nature.* 267:442-444, 1977.
- Rubinstein, K.E., Schneider, R.S. and Ullman, E.F. . *Biochem.Biophys.Res.Comm.* 47:846, 1972.
- Ruddon, R.W. and Johnson, J.M. The effect of nitrogen mustard on DNA template activity impurified DNA and RNA polymerase system. *Mol.Pharmacol.* 4:258, 1968.
- Ruderman, J.M., Welch, D.B., Smith, M.F. and Shoch, D.E. A randomized study of 5-fluorouracil and filtration surgery. *Am.J.Ophthalmol.* 104:218-224, 1987.
- Ruoslahti, E. Fibronectin and its receptors. *Ann.Rev.Biochem.* 57:375-413, 1988.
- Ruoslahti, E., Hayman, E.G., Engvall, E., Cothran, W.C. and Butler, W.T. Alignment of biologically active domains in the fibronectin molecule. *J.Biol.Chem.* 256:7277-7281, 1981.
- Rutherford, R.B. and Ross, R. Platelet factors stimulate fibroblasts and smooth muscle cells quiescent to plasma serum to proliferate. *J.Cell.Biol.* 69:196-203, 1976.
- Saba, T.M. and Jaffe, E. Plasma fibronectin (opsonic glycoprotein): Its synthesis by endothelial cells and role in cardiopulmonary integrity after trauma as related to reticuloendothelial function. *Am.J.Med.* 68:577-594, 1980.
- Sachdev, S., Zou, X. and Higginbotham, E. The effect of 5-fluorouracil impregnated collagen shield implants in filtration surgery. *Invest.Oph.Vis.Sci.(suppl).* 31:3, 1990.
- Sambrook, J., Fritsch, E.F. and Maniatis, T. *Molecular cloning. A laboratory manual*, Cold Spring Harbour:Cold Spring Harbour Laboratort, 1989. Ed. 2nd
- Samuelsson, B., Golyne, M., Granstrom, E., Hamberg, M., Hammarstrom, S. and Malmsten, C. Prostaglandins and thromboxanes. *Ann.Rev.Biochem.* 47:997-1029, 1978.
- Santamaria, J. Steroidal agents: Their systemic and ocular complications. *Ocul.Inflam.Therap.* 1:19-26, 1983.
- Santelli, G. and Valeriot, F. In vivo enhancement of 5-fluorouracil cytotoxicity to AKR leukemia cells by thymidine in mice. *J.Natl.Cancer Inst.* 61:843-847, 1978.

Sarber, R., Hull, B., Merrill, C., Soranno, T. and Bell, E. Regulation of proliferation of fibroblasts of low and high population doubling levels grown in collagen lattices. *Mech.Ageing Develop.* 17:107-117, 1981.

Savage, C.R., Inagami, T. and Cohen, S. The primary structure of epidermal growth factor. *J.Biol.Chem.* 247:7612-7621, 1972.

Savage, F., Grierson, I., Hogg, P., Hiscott, P.S. and McLeod, D. In vitro studies of sodium butyrate as a treatment for proliferative vitreoretinopathy. *Invest.Ophthalmol.Vis.Sci.(Suppl).* 30:393, 1989.

Schermer, A., Galvin, S. and Sun, T. Differentiation related expression of a major 64K corneal keratine in vivo and in culture, suggests limbal location of corneal epithelial stem cells. *J.Cell.Biol.* 103:49, 1986.

Schiff, P.B. and Horwitz, S.B. Taxol stabilizes microtubules in mouse fibroblast cells. *Proc.Natl.Acad.Sci.USA.* 77:1561-1565, 1980.

Schneider, C., King, R.M. and Philipson, L. Genes specifically expressed at growth arrest of mammalian. *Cell.* 54:787-793, 1988.

Schwartz, A.L. and Anderson, D.R. Trabecular Surgery. *Arch.Ophthalmol.* 92:134-138, 1974.

Schweigerer, L., Ferrara, N., Haparanta, T., Neufeld, G. and Gospodarowicz, D. Basic fibroblast growth factor: expression in cultured cells derived from corneal endothelium and lens epithelium. *Exp.Eye.Res.* 46:71-80, 1988.

Seidel, E. Weitere experimentelle untersuchungen ueber die quelle und den verlauf der intraokularen saftstromung. *Arch.F.Ophth.* 104:158, 1921.

Senderoff, R.I., Weber, P.A., Smith, D.R. and Sokoloski, T.D. Evaluation of antiproliferative agents using a cell culture model. *Invest.Ophthalmol.Vis.Sci.* 31:2572-2578, 1990.

Senior, R.M., Griffin, G.L. and Mechan, R.P. Chemotactic responses of fibroblast to tropoelastin and elastin-derived peptides. *J.Clin.Invest.* 70:614-618, 1982.

Senior, R.M., Griffin, G.L. and Mechan, R.P. Val-Gly-Val-Ala-Pro-Gly: A repeating peptide in elastin, is chemotactic for fibroblasts and monocytes. *J.Cell.Biol.* 99:870-874, 1984.

Senior, R.M., Skogen, W.F., Griffin, G.L. and Wilner, G.D. Effects of fibrinogen derivatives upon the inflammatory response. *J.Clin.Invest.* 77:1014-1019, 1986.

Seppa, H.E.J., Grotendorst, G.R., Seppa, S.I., Schiffman, E. and Martin, G.R. The platelet derived growth factor is a chemoattractant for fibroblasts. *J.Cell.Biol.* 92:584-588, 1982.

Sherwood, M.B., Grierson, I., Millar, L. and Hitchings, R.A. Long-term morphologic effects of antiglaucoma drugs on the conjunctiva and Tenon's capsule in glaucomatous patients. *Ophthalmology.* 96:327-335, 1989.

Sherwood, M.B., Khaw, P.T., Doyle, J.W., Smith, M.F. and McGorray, S. Comparison of five minute intraoperative treatments with 5-fluorouracil and mitomycin-c on filtering surgery in the rabbit. *Invest.Ophthalmol.Vis.Sci.(Suppl).* 33:1392, 1992.

Sherwood, M.B., Spaeth, G.L., Simmons, S.T., Nichols, D.A., Walsh, A.M., Steinmann, W.C. and Wilson, R.P. Cysts of Tenon's capsule following filtration surgery: Medical management. *Arch.Ophthalmol.* 105:1517-1521, 1987.

Shimokado, K., Raines, E.W., Madtes, D.K., Barrett, T.B., Benditt, E.P. and Ross, R. A significant part of macrophage-derived growth factor consist of two forms of PDGF. *Cell*. 43:277-286, 1985.

Shinoda, I., Tokida, N., Kuroke, M., Furukawa, S. and Hayashi, K. Demonstration of considerable amount of mouse epidermal growth factor in aqueous humor. *Biochem.Int*. 17:243-248, 1988.

Shuman, M.A., Polansky, J.R., Merkel, C. and Alvarado, J.A. Tissue plasminogen activator in cultured human trabecular meshwork cells. Predominance of enzyme over plasminogen activator inhibitor. *Invest.Ophthalmol.Vis.Sci*. 29:401-405, 1988.

Siegel, R.C. Collagen cross-linking effect of D-penicillamine on cross-linking in vivo. *J.Biol.Chem*. 252:254, 1977.

Silver, I.A., Murrills, R.J. and Etherington, D.J. Micro-electrode studies on the acid micro-environment beneath adherent macrophages and osteoclasts. *Exp.Cell.Res*. 175:266-276, 1988.

Simonian, M.H., Hornsby, P.J., III, C.R., O'Hare, M.J. and Gill, G.N. Characterization of cultured bovine adrenocortical cells and derived clonal lines: Regulation of steroidogenesis and culture lifespan. *Endocrinology*. 105:99-108, 1979.

Sivalingam, A., Kenney, J., Brown, G.C., Benson, W.E. and Donoso, L. Basic fibroblast growth factor levels in the vitreous of patients with proliferative diabetic retinopathy. *Arch Ophthalmol* 108:869-872, 1990.

Skipper, H.E., Bennett, L.L. and Langham, W.H. Overall traces studies with c-14 labelled nitrogen mustard in normal and leukemic mice. *Cancer*. 4:1025, 1951.

Skuta, G.L., Assil, K., Parrish, R.K.II., Folberg, R. and Weinreb, R.N. Filtering surgery in owl monkeys treated with the antimetabolite 5-fluorouridine 5'-monophosphate entrapped in multivesicular liposomes (letter). *Am.J.Ophthalmol*. 103:714-715, 1987.

Skuta, G.L., Beeson, C.C., Higginbotham, E.J., Lichter, P.R., Musch, D.C., Bergstrom, T.J., Klein, T.B. and Falck, F.Y.Jr. Intraoperative mitomycin versus postoperative 5-fluorouracil in high-risk glaucoma filtering surgery. *Ophthalmology*. 99:438-444, 1992.

Smyth, R, Kitada, S. and Lee, D.A. Expression of transferrin receptors on fibroblasts from Tenon's capsule of the human eye. *Invest.Ophthalmol.Vis.Sci*. 31:63, 1990.

Snyder, R.W., Lambrou, F.H. and Williams, G.A. Intraocular fibrinolysis with recombinant human tissue plasminogen activator. Experimental treatment in a rabbit model. *Arch.Ophthalmol*. 105:1277-1280, 1987.

Snyderman, R., Phillips, J. and Mergenhagen, S.E. Polymorphonuclear leucocyte chemotactic activity in rabbit serum and guinea pig serum treated with immune complexes: Evidence for c5a as the major chemotactic factor. *Infect.Immunol*. 1:521-525, 1970.

Sobel, J.D. and Gallin, J.I. Polymorphonuclear leukocyte and monocyte chemoattractants produced by human fibroblasts. *J.Clin.Invest*. 63:609-618, 1979.

Sommer, A. Intraocular pressure and glaucoma (Editorial). *Am.J.Ophthalmol*. 107:186-188, 1989.

Soong, H.K., McClenic, B., Varani, J., Hassan, T., Huang, S.C.M. and Brenz, R. EGF does not enhance corneal epithelial cell motility. *Invest.Ophth.Vis.Sci*. 30:1808-1812, 1989.

Soshan, S. and Gross, J. Biosynthesis and metabolism of collagen and its role in tissue repair processes. *Isr.Med.J.* 10:537-561, 1974.

Spencer, E.M., Skover, G.R. and Hunt, T.K. Somatomedins: Do they play a pivotal role in wound healing? In: *Growth factors and other aspects of wound healing: Biological and clinical implications*, edited by Barbul, A., Pines, E. and Caldwell, M. New York: Alan R , 1994, p. 103-116.

Spiegelmann, S., Nayak, R., Sawyer, R., Stolfi, R. and Martin, D. Potentiation of the anti-tumor activity of 5FU by thymidine and its correlation with the formation of (5FU) RNA. *Cancer.* 45:1129-1134, 1980.

Sporn, M.B., Roberts, A.B., Shull, J.H., Smith, J.M., Ward, J.M. and Sodek, J. Polypeptide transforming growth factor isolated from bovine sources and used for wound healing in vitro. *Science.* 219:1329-1331, 1983.

Sporn, M.B., Roberts, A.B., Wakefield, L.M. and Assoian, R.K. Transforming growth factor-B : Biological function and chemical structure. *Science.* 233:532-534, 1986.

Sporn, M.B., Roberts, A.B., Wakefield, L.M. and de Crombrughe, B. Some recent advances in the chemistry and biology of transforming growth factor beta. *J.Cell.Biol.* 105:1039-1045, 1987.

Sporn, M.B. and Roberts, A.B. Peptide growth factors are multifunctional. *Nature.* 332:217-219, 1988.

Sporn, M.B. and Roberts, A.B. *Peptide growth factors and their receptors 1*, New York:Springer-Verlag., 1990.

Stanulis-Praeger, B.M. and Gilchrest, B.A. Growth factor responsiveness declines during adulthood for human skin derived cells. *Mech.Ageing.Develop.* 35:185-198, 1986.

Starita, R.J., Fellman, R.L., Spaeth, G.L., Poryzees, E.M., Greenidge, K.C. and Traverso, C.E. Short- and long-term effects of postoperative corticosteroids on trabeculectomy. *Ophthalmology.* 92:938-946, 1985.

Steinmann, T.L., Thompson, H.W. and Maroney, K.M. Changes in epithelial epidermal growth factor receptor and lacrimal gland EGF concentration after corneal wounding. *Invest.Ophthalmol.Vis.Sci.* 31:55, 1990.

Stewart, R.H., Kimbrough, R.L., Bach, H. and Allbright, M. Trabeculectomy and modifications of trabeculectomy. *Ophthalmic Surg* 10:76-80, 1979.

Strauss, G.H., Dunn, E., Haymond, R., Scimeca, J.M., Bodiford, G., Hook, J. and Taube, T. Effect of r-tpa on wound healing in filtration surgery. *Invest.Oph.Vis.Sci.(suppl).* 31:86, 1990.

Sturmer, J., Broadway, D.C. and Hitchings, R.A. Young Patient trabeculectomy: Assessment of Risk Factors for failure. *Ophthalmology* 100:928-939, 1993.

Tahery, M.M. and Lee, D.A. Review: pharmacologic control of wound healing in glaucoma filtration surgery. *J.Ocul.Pharmacol.* 5:155-179, 1989.

Tan, E.M.L., Rouda, S., Greenbaum, S.S., Moore, J.H.Jr., Fox, J.W. and Sollberg, S. Acidic and basic fibroblast growth factors down-regulate collagen gene expression in keloid fibroblasts. *Am.J.Path.* 142:463-470, 1993.

Teng, C.C., Chi, H.H. and Katzin, H.M. Histology and mechanism of filtering operations. *Am.J.Ophthalmol.* 47:16-34, 1959.

Terranova, V.P., DiFlorio, R., Lyall, R.M., His, S., Friesel, R. and Maciag, T. Human endothelial cells are chemotactic to endothelial cell growth factor and heparin. *J.Cell.Biol.* 101:2330-2334, 1985.

Tervo, T, Setten, G-B van, Paallysaho, T, Tarkkanen, A and Tervo, K Wound healing of the ocular surface. *Ann.Med.* 24:19-27, 1992.

Tervo, T, Sulonen, J, Valtonen, S, Vannas, A and Virtanen, I Distribution of fibronectin in human and rabbit corneas. *Exp.Eye.Res.* 42:399-406, 1986.

The Fluorouracil Filtering Surgery Study Group., Fluorouracil filtering surgery study one-year follow-up. *Am.J.Ophthalmol.* 108:625-635, 1989.

Thiele, C.J., Reynolds, C.P. and Israel, M.A. Decreased expression of N-myc precedes retinoic acid-induced morphological differentiation of human neuroblastoma. *Nature.* 313:404, 1985.

Toole, B.D. Glycosaminoglycans in morphogenesis. In: *Cell Biology of the Extracellular Matrix*, edited by Hay, E.D. New York: Plenum, 1981,

Tripathi, A.J., Tripathi, B.J., Millard, C.B. and Tripathi, R.C. Response of trabecular cells in vitro to bFGF. *Invest.Ophthalmol.Vis.Sci.* 31:227, 1990.

Tripathi, B.J., Geanon, J.D. and Tripathi, J.C. Distribution of tissue plasminogen activator in human and monkey eyes. *Ophthalmology.* 94:1434-1438, 1987.

Tripathi, R.C., Borisuth, N.S.C. and Tripathi, B.J. Growth factors in the aqueous humour, and their therapeutic implications in glaucoma and anterior segments disorders of the human eye. *Drug.Dev.Res.* 22:1-23, 1991a.

Tripathi, R.C., Borisuth, N.S.C., Tripathi, B.J. and Fang, V.S. Analysis of human aqueous humor for epidermal growth factor. *Exp.Eye.Res.* 53:407-409, 1991b.

Tripathi, R.C., Kolli, S.P. and Tripathi, B.J. Fibroblast growth factor in the eye and prospects for its therapeutic use. *Drug.Dev.Res.* 19:225-237, 1990.

Tripathi, R.C., Millard, C.B., Tripathi, B.J. and Reddy, V. A molecule resembling fibroblast growth factor in aqueous humour. *Am.J.Ophthalmol.* 106:230-231, 1988.

Tripathi, R.C., Millard, C.B. and Tripathi, B.J. Protein composition of human aqueous humor: SDS-PAGE analysis of surgical and post-mortem samples. *Exp.Eye.Res.* 48:117-130, 1989.

Tripathi, R.C., Millard, C.B., Tripathi, B.J., Borisuth, N.S.C., Neely, K.A. and Ernest, J.T. Aqueous humor of cat contains fibroblast growth factor and transferrin similar to those in man. *Exp.Eye.Res.* 50:109-112, 1990a.

Tripathi, R.C., Millard, C.B., Tripathi, B.J. and Noronha, A. Tau fraction of transferrin is present in human aqueous humor and is not unique to cerebrospinal fluid. *Exp.Eye.Res.* 50:541-547, 1990b.

Tripathi, R.C., Park, J.K., Tripathi, B.J. and Millard, C.B. Tissue plasminogen activator in human aqueous humor and its possible therapeutic significance. *Am.J.Ophthalmol.* 106(6):719-722, 1988.

Tripathi, R.C., Raja, S.C. and Tripathi, B.J. Prospects for epidermal growth factor in the management of corneal disorders. *Surv.Ophthalmol.* 34:456-462, 1990.

Tripathi, R.C., Tripathi, B.J. and Raja, S.C. Prospects for growth factor therapy of cataracts. *Sci.Res.J.* 1:131-147, 1989.



Tsao, D., Morita, A., Bella, A., Jr., Luu, P. and Kim, Y.S. Differential effects of sodium butyrate, dimethyl sulfoxide, and retinoic acid on membrane-associated antigen, enzymes, and glycoproteins of human rectal adenocarcinoma cells. **Cancer.Res.** 42:1052-1058, 1982.

Tseng, W-C., Medina, D. and Randerath, K. Specific inhibition of transfer RNA methylation and modification in tissues of mice treated with 5-fluorouracil. **Cancer.Res.** 38:1250-1257, 1978.

Tsukamoto, Y., Helsel, W.E. and Wahl, S.M. Macrophage production of fibronectin, a chemoattractant for fibroblasts. **J.Immunol.** 127:673-678, 1981.

Tzeng, D.Y., Deuel, T.F., Huang, J.S. and Baehner, R.L. Platelet-derived growth factor promotes human peripheral monocyte activation. **Blood.** 66:179-183, 1984.

Ullrich, A., Coussens, L. and Hayflick, J.S. Human epidermal growth factor receptor cDNA sequence and aberrant expression of the amplified gene in A431 epidermoid carcinoma cells. **Nature.** 309:418-425, 1984.

Vadot, E., Mirshahi, M. and Merignargues, G. Transferrin receptors on retinal capillary endothelium. **Ophthalmic.Res.** 20:61, 1988.

van Bockxmeer, F.M., Martin, C.E. and Constable, I.J. Models for assessing scar tissue inhibitors. **Retina.** 5/4:239-252, 1985.

van Buskirk, E.M. Cysts of Tenon's capsule following filtration surgery. **Am.J.Ophthalmol.** 94:522-527, 1982.

van Setten, G-B. Epidermal growth factor in human tear fluid: Increased release but decreased concentrations during reflex tearing. **Curr.Eye.Res.** 9:79-83, 1990.

van Setten, G-B., Tervo, T., Tarkkanen, A., Pesonen, K., Viinikka, L. and Perheentupa, J. Epidermal growth factor is a constant component of normal human tear fluid. **Graefe's.Arch.Clin.Exp.Ophthalmol.** 227:84-87, 1989.

Van Story-Lewis, P.E. and Tenenbaum, H.C. Glucocorticoid inhibition of fibroblast contraction of collagen gels. **Biochem.Pharmacol.** 35,8:1283-1286, 1986.

Verdoorn, C., Renardel de Lavalette, V.W., Dalma-Weizhausz, J., Orr, G.M., Sorgente, N. and Ryan, S.J. Cellular migration, proliferation, and contraction. An in vitro approach to a clinical problem - proliferative vitreoretinopathy. **Arch.Ophthalmol.** 104:1216-1219, 1986.

Verstraete, M. and Collen, D. Thrombolytic therapy of the 80's. **Blood.** 67:1529-1541, 1986.

Verstraeten, T.C. and Wilcox, D.K. Effect of vitamin A on migration of human RPE cells in vitro. **Invest.Ophthalmol.Vis.Sci.** 28:208, 1987.

Vinore, S.A., Marangos, P.J. and Ko, L. Butyrate-induced increase in neuron-specific enolase and ornithine decarboxylase in anaplastic glioma cells. **Brain.Res.** 281:23-28, 1982.

Wahl, S.M., Hunt, D.A., Wakefield, L.M., McCartnery, F.N., Wahl, L.M., Roberts, A.B. and Sporn, M.B. Transforming growth factor type beta induces monocyte chemotaxis and growth factor production. **Proc.Natl.Acad.Sci.USA.** 84:5788-5792, 1987.

Watanabe, H., Ohashi, Y., Kinoshita, S., Danjo, S., Manabe, R., Yanaihara, C. and Oshiden, K. Localization of epidermal growth factor in ocular and periorcular tissues of rats. **Invest.Ophthalmol.Vis.Sci.(Suppl).** 30:149, 1989.

Watanabe, K., Nakagawa, S. and Nishida, T. Stimulatory effects of fibronectin and EGF on migration of corneal epithelial cells. **I.O.V.S.** 28:205-211, 1987.

- Watanabe, K., Nakagawa, S. and Nishida, T. Chemotactic and haptotactic activities of fibronectin for cultured rabbit corneal epithelial cells. *I.O.V.S.* 29:572-577, 1988.
- Watson, P.G. Surgery of the glaucomas. *Brit.J.Ophthalmol.* 56:299-318, 1972.
- Watson, P.G. and Grierson, I. The place of trabeculectomy in the treatment of glaucoma. *Ophthalmology.* 88:175-196, 1981.
- Weinreb, R.N. Adjusting the dose of 5-fluorouracil after filtration surgery to minimize side effects. *Ophthalmology.* 94:564-570, 1987.
- Weiss, J.F. and Belkin, M. Glucocorticosteroid inhibition of intraocular proliferation. *Am.J.Ophthalmol.* 92:133, 1981.
- Weller, M., Clausen, R., Heimann, C. and Wiedemann, P. Iron binding proteins in the human vitreous: Lactoferrin and transferrin in health and in proliferative intraocular disorders. *Ophthalmic.Res.* 22:194-200, 1990.
- White, W.F., Barlow, G.H. and Mozen, M.M The isolation and characterization of plasminogen activators (urokinase) from human urine. *Biochem.* 5:2160-2169, 1960.
- Whyte, P., Buchkovich, K.J. and Horowitz, J.M. Association between an oncogen and an anti-oncogene: The adeno virus E1A proteins bind to the retinoblastoma gene product. *Nature.* 434:124-129, 1988.
- Wilkinson, D.S., Tisty, T.D. and Hanas, R.J. The inhibition of ribosomal RNA synthesis and maturation in Novikoff hepatoma cells by 5-fluorouridine. *Cancer.Res.* 35:3014-3020, 1975.
- Williams, G.A., Lambrou, F.H., Jaffe, G.J., Snyder, R.W., Green, G.D.J., Devenyi, R.G. and Abrams, G.W. Treatment of postvitrectomy fibrin formation with intraocular tissue plasminogen activator. *Arch.Ophthalmol.* 106:1055, 1988.
- Williams, I.F., McCullagh, K.G. and Silver, I.A. The distribution of types I and III collagen and fibronectin in the healing equine tendon. *Conn.Tiss.Res.* 12:211-227, 1984.
- Wilson, M.R. and Reaves, H. Additional comments on the effects of triamcinolone injection (letter). *Arch.Ophthalmol.* 105:1166, 1987.
- Wilson, R.P., Cantor, L., Katz, L.J., Schmidt, C.M., Steinmann, W.C. and Allee, S. Aqueous shunts: Molteno vs Schocket. *Ophthalmology.* 99:672-678, 1992.
- Winter, D.F., Jones, M.A., Simmons, S.T. and Smith, R.S. A histologic analysis of 5-fluorouracil liposomal delivery system following subconjunctival injection in rabbits. *Invest.Ophthalmol.Vis.Sci.(Suppl).* 28:271, 1987.
- Wiseman, D.M., Poverini, P.J., Camp, D.W. and Leibovich, S.J. Transforming growth factor-beta is chemotactic for human monocytes and induces the expression of angiogenic activity. *Biochem.Biophys.Res.Comm.* 157:793, 1988.
- Wohlhueter, R.M., Mclvor, R.S. and Plagemann, P.G.W. Facilitated transport of uracil and 5-fluorouracil, and permeation of orotic acid into cultured mammalian cells. *J.Cell.Physiol.* 104:309-319, 1980.
- Woost, P.G., Brightwell, J., Eiferman, R.A. and Schultz, G.S. Effect of growth factors with dexamethasone on healing of rabbit corneal stromal incisions. *Exp.Eye.Res.* 40:47-60, 1985.
- Woost, P.G., Jumblatt, M.M., Eiferman, R.A. and Schultz, G.S. Growth factors and corneal endothelial cells: I. Stimulation of bovine corneal endothelial cell DNA synthesis by defined growth factors. *Cornea.* 11:11, 1992.

Worthen, D.M. and Cleveland, P.H. Fibronectin production by cultured human trabecular meshwork cells. *Invest.Ophthalmol.Vis.Sci.* 23:265-269, 1982.

Wrana, J.L., Sodek, J., Ber, R.L. and Bellows, C.G. The effects of platelet derived transforming growth factor beta on normal human diploid gingival fibroblasts. *Eur.J.Biochem.* 159:69-76, 1986.

Wright, J.A. Morphology and growth rates of Chinese hamster cells cultured in the presence of sodium butyrate. *Exp.Cell.Res.* 78:456-460, 1973.

Wylie, D.E., Damsky, C.H. and Buck, C.A. Studies on the function of cell surface glycoproteins.I.Use of antisera to surface membranes in the identification of membrane components relevant to cell-substrate adhesion. *J.Cell.Biol.* 80:385-402, 1979.

Yamada, K.M., Kennedy, D.W., Kimata, K. and Pratt, R.M. Characterization of fibronectin interactions with glycosaminoglycans and identification of active proteolytic fragments. *J.Biol.Chem.* 255:6055-6063, 1980.

Yamada, K.M. and Kennedy, D.W. Amino acid sequence specificities of an adhesive recognition signal. *J.Cell.Biochem.* 28:99-104, 1985.

Yamamoto, T., Varani, J., Kaz Soong, H. and Lichter, P.R. Effect of 5-fluorouracil and mitomycin-c on cultured rabbit subconjunctival fibroblasts. *Ophthalmology.* 97:1204-1210, 1990.

Yayon, A., Klagsbrun, N., Esko, J.D., Ledder, P. and Ornitz, D.A. Cell surface, hebrin-like molecules are required for binding of basic fibroblast growth factor to it's high infinity receptor. *Cell.* 64:841-848, 1991.

Yeo, J.H., Sadeghi, J. and Campochiaro, P.A. Intravitreal fibronectin and platelet-derived growth factor; new model for traction retinal detachment. *Arch.Ophthalmol.* 104:417-421, 1986.

Yu, T. and Okamura, R. Quantitative study of characteristic aqueous humor transferrin, serum transferrin, and desialized serum transferrin in aqueous humor. *Jpn.J.Ophthalmol.* 32:268-274, 1988.

Zamarron, C., Lijnon, H.R. and Collen, D. Competitive inhibition by human plasma of the activation of plasminogen by pro-urokinase. *Thromb.Haemost.(abst).* 54:102, 1985.

Zeitz, M., Ruiz-Torres, A. and Merker, H.J. Collagen metabolism in granulating wounds of rat skin. *Arch.Dermatol.Res.* 263:207-214, 1978.

Zetter, B.R., Martin, G.R. and Birdwell, C.R. Role of High Molecular Weight Glycoprotein in Cellular Morphology, Adhesion, and Differentiation. *Ann.N.Y.Acad.Sci.* 312:299-316, 1978.

Zigmond, S.H. Ability of polymorphonuclear leukocytes to orient in gradients of chemotactic factors. *J.Cell.Biol.* 75:606-616, 1977.

Zigmond, S.H. and Hirsch, J.G. A Leukocyte Locomotion and Chemotaxis: New Methods For Evaluation and Demonstration of a Cell Derived Chemotactic Factor. *J.Exp.Med.* 137:387-410, 1973.

## **Appendix (equipment suppliers)**

Arnold & Horwell Ltd, West Hampstead, London, U.K.  
Amersham, Aylesbury, Buckinghamshire, U.K.  
Alcon, Fort Worth, TX, USA./Hertfordshire, U.K.  
Biorad, Santa Ana, CA, USA.  
Bristol-Myers, Evansville, IND, USA.  
Baxter Scientific Products, IL, USA.  
Coulter, Luton, England, U.K.  
Costar, High Wycombe, Bucks, U.K./Cambridge MA, USA.  
Chiron Corp, Emeryville, CA, USA.  
Cambridge Instruments, Deerfield, IL, USA.  
Difco, East Mosley, Surrey, U.K.  
David Bull laboratories, Warwick, U.K.  
Dakopatts, Glostrup, Denmark.  
Fisher Scientific, Fair Lawn, NJ, USA.  
Gibco BRL/Life Technologies  
    European Division, Uxbridge, London, UK.  
    American Division, Long Island, NY, USA.  
ICN Biochemicals Ltd, Bucks, U.K.  
Kodak, Rochester, NY, USA.  
Kyowa, Essex, U.K.  
Life Technologies - See Gibco  
Leec Incubator, Colwick, Nottingham, U.K.  
Mayers Heamotoxylin - BDH, Essex, U.K.  
Minitab Corporation, State College, PA, USA.  
Miles Scientific, Elkhart, IN, USA.  
Neuro Probe, Cabin John, MD, USA.  
Nucleopore, Pleasanton, CA, USA  
Nikon, Hialeah, FL, USA.  
Nalgene, (RNA Tubes), Hereford, UK  
Packard, Berks, U.K./Meriden, CT, USA.  
Phillips (Microwave), Croydon, Surrey, U.K.  
Roche, Nutley, NJ, USA.  
Sterilin, Feltham, England, U.K.  
Sigma, Poole, U.K./St Louis, MO, USA.

Storz, St Louis, MO, USA.  
Southern Scientific Instruments, Orlando, FL, USA.  
Stratagene, Cambridge, U.K.  
Technicon Co., Chauncey, NY, USA.  
Vickers Instruments, Bedfordshire, U.K.  
Weck, Research Triangle Park, NC, USA.  
Whatman, Maidstone, U.K.  
Wardray, London, U.K.  
Zeiss, Thornwood, NY, USA.