

Devices to Assist the Insertion of Colonoscopes

Charles Alexander Mosse, BA(Hons), MSc

*Thesis submitted for the Degree of
Doctor of Philosophy (PhD) of the University of London*



Department of Medical Physics and Bioengineering
University College London

October 1999

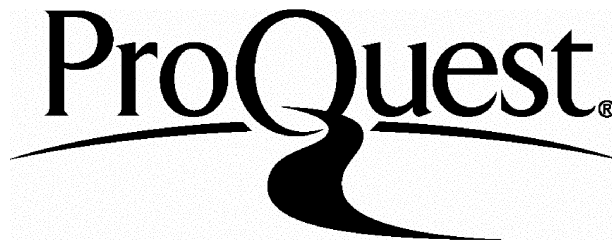
ProQuest Number: U644350

All rights reserved

INFORMATION TO ALL USERS

The quality of this reproduction is dependent upon the quality of the copy submitted.

In the unlikely event that the author did not send a complete manuscript and there are missing pages, these will be noted. Also, if material had to be removed, a note will indicate the deletion.



ProQuest U644350

Published by ProQuest LLC(2016). Copyright of the Dissertation is held by the Author.

All rights reserved.

This work is protected against unauthorized copying under Title 17, United States Code.
Microform Edition © ProQuest LLC.

ProQuest LLC
789 East Eisenhower Parkway
P.O. Box 1346
Ann Arbor, MI 48106-1346

Abstract

The thesis starts by describing the colon and the history and workings of the endoscope. It then suggests that the fundamental problem when inserting a colonoscope is that as one flexible tube (the colonoscope) is pushed along another poorly supported flexible tube (the colon), it tends to catch and push and form loops. The literature concerning devices for overcoming this problem is reviewed and the first phase of the thesis ends with an investigation of the forces applied by clinicians to the colonoscope during routine clinical procedures.

The body of the thesis describes the following four novel devices intended to minimise this fundamental problem.

- 1) Water is pumped through an array of backward facing nozzles mounted onto the endoscope tip. As water accelerates through the nozzles, the reaction force propels the endoscope. The forces and pressures are analysed theoretically and compared with experimental results. Prototypes, some incorporating atomisers to ‘blunt’ the jets, are described and results are presented from live pigs and models using excised porcine colon.
- 2) A “crawler” has two suction feet that can be moved together or apart using concertina bellows or a Bowden cable. To take a step, one foot advances while the other grips the colon wall with suction, then the suction is switched over, so that the first foot grips whilst the other advances. Results with model colons are presented.
- 3) Electrodes placed at the tapering end of a lozenge shaped piece of acrylic stimulate the bowel to contract, squeezing the taper forward, which in turn brings the electrodes into contact with new tissues. *In vivo* results are presented.
- 4) A disposable sleeve with a lubricious hydrogel coating is attached to the endoscope to minimize friction. Results from bench tests are presented.

The thesis ends with some concluding comments and suggestions for future work.

Acknowledgements

I would like to thank Dr Tim Mills, my supervisor at University College London, for his constant help and support throughout this project. I have been very lucky to have a supervisor who not only has innovative ideas but is also available and willing to discuss problems on a daily basis.

I would also like to thank Professor Paul Swain whose playfulness and love of endoscopic instruments has been inspiring. Professor Swain has generously acted as a joint supervisor for this PhD despite being a consultant gastroenterologist at the Royal London Hospital, with no official involvement with University College. He has given freely of his time, often sacrificing parts of his weekend.

This PhD project involved a great deal of time in the Mechanical Workshop of the Department of Medical Physics and I would like to thank all the staff there for welcoming me and for their help when I became stuck. Thanks are also due to the staff at the Gastrointestinal Intestinal Research Unit at the Royal London Hospital for being so friendly and helpful to a free-loading outsider.

During the early part of the project, I was fortunate to receive encouragement, practical help and enthusiasm from Professor Duncan Bell. From my personal point of view, it was a loss when he moved to Sunderland, so far from London.

I would like to thank my wife, Lucy, for her support and my children, whose prurient interest in colonoscopy has enlivened many suppers.

Finally, I would like to thank all the above for making what could have been a chore into three very enjoyable years.

CONTENTS

LIST OF TABLES.....	7
LIST OF FIGURES.....	7
1 INTRODUCTION.....	11
1.1 THE NEED FOR IMPROVEMENTS TO THE METHOD OF INSERTING COLONOSCOPES.....	11
1.2 THE REQUIREMENT FOR COLONOSCOPY.....	12
1.2.1 Colorectal Cancer.....	12
1.2.2 Other Indications for colonoscopy.....	15
1.3 ANATOMY OF THE COLON AND RECTUM.....	16
1.4 THE COLONOSCOPE.....	20
1.4.1 Rigid Endoscopy.....	21
1.4.2 Semi-flexible endoscopy.....	22
1.4.3 Flexible Colonoscopes.....	23
1.4.4 The modern colonoscope.....	26
1.5 CONCLUSION.....	32
2 LITERATURE; PATENTS AND ARTICLES RELATING TO IMPROVEMENTS IN INSERTING COLONOSCOPES.....	33
2.1 INTRODUCTION.....	33
2.2 OVERTUBES AND SPINES.....	33
2.3 TIP PROPULSION.....	36
2.3.1 Earthworms.....	36
2.3.2 Suction crawlers.....	39
2.3.3 Snakes.....	39
2.3.4 Millipedes.....	40
2.3.5 Lizards and ants.....	43
2.3.6 Octopus.....	44
2.4 SYSTEMS THAT DO NOT APPLY TRACTION ONLY AT THE TIP.....	44
2.4.1 Wheels, pulleys and vibrators.....	44
2.4.2 Everting toposcopic endoscopy.....	46
2.4.3 Wireless endoscopy.....	47
2.4.4 Virtual enteroscopy.....	48
2.5 CONCLUSION.....	50
3 MEASUREMENT OF THE FORCES EXERTED BY THE CLINICIAN ON THE ENDOSCOPE DURING COLONOSCOPY.	51
3.1 INTRODUCTION.....	51
3.2 METHOD.....	52
3.2.1 Mechanical design.....	52
3.2.2 Electronics and computing.....	54
3.2.3 Positioning system.....	56
3.3 CALIBRATION.....	57
3.4 FORCE MEASUREMENTS DURING COLONOSCOPY IN PATIENTS.....	58
3.5 DISCUSSION.....	61
3.6 CONCLUSION.....	63
4 THE WATER JET PROPELLED ENDOSCOPE	67
4.1 INTRODUCTION.....	67
4.2 THE THRUST FROM A JET.....	68
4.2.1 Experiment to confirm ' $F = 2PA$ '.....	69
4.2.2 Pressurised water supply.....	71
4.2.3 The relationship between thrust, the number of holes and the total cross sectional area of the holes. 73	

4.2.4	<i>The relationship between pressure and thrust for a prototype jet propelled endoscope</i>	75
4.3	THE DESIGN AND CONSTRUCTION OF PROTOTYPES.....	79
	<i>High Pressure Over-tube</i>	79
4.3.2	<i>Dual Channel Endoscope</i>	80
4.3.3	<i>Endoscopes with external tubes</i>	81
4.3.4	<i>Mechanical clamping to the endoscope</i>	83
4.4	RESULTS WITH PROTOTYPE ENDOSCOPES.....	85
4.4.1	<i>Tests with model colons</i>	85
4.4.2	<i>Tests in vivo</i>	87
4.5	SAFETY CONSIDERATIONS RELATING TO BURSTING AND PERFORATION OF THE COLON.....	87
4.5.1	<i>Bursting of the colon</i>	88
4.5.2	<i>Perforation of the colon</i>	91
4.5.3	<i>Perforation of the colon – experiment</i>	93
4.6	THE DESIGN OF NOZZLES TO PRODUCE HIGH VELOCITY ATOMISED SPRAYS.....	97
	<i>Introduction</i>	97
4.6.1	<i>The impinging jet atomiser</i>	99
4.7	PROTOTYPE JET PROPULSION HEAD WITH ATOMISING NOZZLES.....	103
4.7.1	<i>Results using the head with atomising nozzles</i>	104
4.8	CONCLUSION.....	106
USING A ‘SUCTION CRAWLER’ TO PULL THE ENDOSCOPE.....		107
5.1	INTRODUCTION.....	107
5.2	THE PRINCIPLES UNDERLYING THE DESIGN OF THE SUCTION SYSTEM.....	108
5.2.1	<i>First element; - the vacuum pump</i>	109
5.2.2	<i>Second element; - the vacuum tubing</i>	110
5.2.3	<i>Third element; - the vacuum chambers</i>	114
5.3	DESIGN AND CONSTRUCTION OF PROTOTYPES - SUCTION CRAWLERS USING BELLOWS.....	118
5.3.1	<i>Experiments and results from suction crawlers using bellows</i>	124
5.3.2	<i>Reasons for abandoning bellows</i>	125
METHODS USED FOR CONSTRUCTING CABLE DRIVEN SUCTION CRAWLERS.....		131
5.4.1	<i>Method for making the third generation cable driven suction crawler</i>	133
5.5	EXPERIMENTS AND RESULTS WITH PROTOTYPE SUCTION CRAWLERS USING CABLES.....	136
5.6	CONCLUSION.....	139
6 STIMULATING THE MUSCLES OF THE GI TRACT SO THAT THEY PROPEL THE ENDOSCOPE.....		141
6.1	INTRODUCTION.....	141
6.2	SIMPLE PHYSIOLOGY.....	144
6.2.1	<i>Cell membranes</i>	145
6.2.2	<i>Muscle contraction</i>	147
6.2.3	<i>Activation of smooth muscle contraction</i>	149
6.3	LITERATURE REVIEW –.....	150
6.3.1	<i>Conclusion to the literature survey</i>	154
METHOD - DESCRIPTION OF THE DEVICES THAT WERE BUILT.....		155
6.4.1	<i>Device E1</i>	156
6.4.2	<i>Devices E2 and E3</i>	157
6.4.3	<i>Devices E4 and E5</i>	158
6.4.4	<i>Summary of devices</i>	158
6.5	EXPERIMENTAL METHODS AND RESULTS.....	159
6.5.1	<i>In-vitro experiments</i>	159
6.5.2	<i>In-vivo experiments</i>	161
6.5.3	<i>In-vivo, with surgical access to the small bowel</i>	164
6.5.4	<i>In-vivo, with surgical access to the large bowel</i>	167
6.6	CONCLUSIONS.....	168
7 THE USE OF A LUBRICATING SLEEVE TO FACILITATE PUSHING A COLONOSCOPE ALONG THE BOWEL.....		170
7.1	INTRODUCTION - HYDROGELS.....	170
7.1.1	<i>The proposed hydrogel coated disposable sleeve for an endoscope</i>	173

7.2	THE FRICTIONAL PROPERTIES OF AN ENDOSCOPE SHAFT COMPARED WITH THOSE OF HYDROGEL COATED CATHETERS.	175
7.2.1	<i>Methods for finding coefficients of friction.</i>	177
7.2.2	<i>Experiments and results.</i>	182
7.2.3	<i>Discussion of the results</i>	185
7.2.4	<i>Conclusions regarding the frictional properties of an endoscope shaft compared with those of hydrogel coated catheters.</i>	187
7.3	PROTOTYPE DEVELOPMENT	188
7.3.1	<i>Patient safety.</i>	189
7.4	PROTOTYPE MANUFACTURE.....	190
7.5	CONCLUSION	190
8	CONCLUDING REMARKS	192
8.1	WATER JET	192
8.2	SUCTION CRAWLER	193
8.3	ELECTRICAL STIMULATION OF THE MUSCLES IN THE GUT WALL.....	194
8.4	HYDROGEL COATED SLEEVE.....	195
8.5	FINAL COMMENTS.....	196
	APPENDIX 1 - MODELS OF THE COLON.	198
A1	INTRODUCTION.	198
A2	PLASTIC AND RUBBER MODEL COLONS.....	199
A.3	METHODS FOR MAKING COLON MODELS USING EXCISED PORCINE.	201
	RESULTS AND CONCLUSIONS	206
	APPENDIX 2 FORCES EXERTED DURING OESOPHAGEAL DILATATION	207
	APPENDIX 3 COPY OF A DOCUMENT WRITTEN EARLY IN THE PHD PROJECT OUTLINING THE DIFFERENT APPROACHES THAT THEN APPEARED POSSIBLE.....	213
	REFERENCES	223

List of tables

1.1	DISTRIBUTION OF BOWEL CANCER BY SITE	13
1.2	SURVIVAL RATES AMONG PATIENTS WITH RECTAL CANCER AT ST MARK'S HOSPITAL.	13
1.3	LENGTHS AND ATTACHMENTS OF PARTS OF THE LARGE BOWEL	19
1.4	A SUMMARY OF THE HISTORY OF LOWER GI ENDOSCOPY	21
3.1	CROSS-TALK BETWEEN CHANNELS.	57
3.2	SUMMARY OF FIRST ELEVEN COLONOSCOPIES DURING WHICH RECORDINGS WERE MADE.	58
4.1	RESULTS OF TESTS TO SHOW WHETHER IN PRACTICE THRUST DEPENDS SOLELY ON THE PRESSURE AND THE TOTAL CROSS SECTIONAL AREA OF THE NOZZLES.	74
4.2	TENSILE BREAKING LOAD PER UNIT WIDTH OF HUMAN LARGE INTESTINE.	89
4.3	FORCE REQUIRED TO PERFORATE MEMBRANES WITH VARIOUS PLUNGERS.	94
4.4	THE THRUST DEVELOPED BY IMPINGING AND NON-IMPINGING JETS.	101
5.1	COMPUTED AND MEASURED FLOW RATES FOR VARIOUS SUCTION TUBE DIAMETERS	113
5.2	RESULTS ACHIEVED WITH THE APPARATUS ILLUSTRATED IN FIGURE 5.4	116
5.3	THE STAGES INVOLVED IN ADVANCING ONE STEP	130
6.1	SUMMARY OF THE DEVICES THAT WERE CONSTRUCTED.	158
6.2	THE EFFECT OF VARYING VOLTAGE ACROSS THE ELECTRODES OF DEVICE E4 PLACED IN PIG OESOPHAGUS.	163
6.3	SUMMARY OF THE SPEED AT WHICH THE DEVICES PROGRESSED ALONG THE BOWEL OF A LIVE PIG WITH VARIOUS SETTINGS OF THE GRASS STIMULATOR.	164
7.1	SUMMARY OF EXPERIMENTS CONCERNING COLON TISSUES SLIDING AGAINST AN ENDOSCOPE AND AGAINST HYDROGEL COATED CATHETERS.	183

List of Figures

1.1	SURVIVAL OF 777 CONSECUTIVE PATIENTS WITH COLORECTAL CANCER STRATIFIED BY TUMOUR STAGE.	14
1.2	SCHEMATIC AND NATURALISTIC DRAWINGS OF THE COLON.	17
1.3a	BARIUM ENEMA X-RAY OF THE COLON.	18
1.3b	X-RAY SHOWING A COLONOSCOPE THAT HAS BECOME LOOPED.	18
1.4	A SNARE AND A POLYP TO BE SNARED.	25
1.5	SCHEMATIC DIAGRAM OF THE PULLING SYSTEM USED BY PROVENZALE AND REVIGNAS.	25
1.6	THE EVIS PCF 230 COLONOSCOPE WITH BIOPSY FORCEPS.	28
1.7	FLEXIBLE BODY AND HANDLE FROM AN OLYMPUS 16F-2S ENDOSCOPE.	29
1.8	BENDING AND TIP SECTIONS OF A FLEXIBLE FIBRE OPTIC ENDOSCOPE	31
2.1	VARIABLE STIFFNESS OVERTUBE (BAUERFEIND 1979)	34
2.2	FLEXIBLE/STIFF SPINE IN A TUBULAR ENDOSCOPE. FROM STURGES 1991 ARTICLE	35
2.3	THE EARTHWORM FROM FRAZER'S 1979 PATENT.	37
2.4	THE EARTHWORM FROM LYDDY ET AL, 1987 PATENT	37
2.5	THE WORM AND A SINGLE SECTION OF THE WORM FROM GRUNDFEST ET AL, 1994 PATENT.	38
2.6	WALKING SYSTEM FROM UTSUGI'S 1979 PATENT	41

2.7	THREE GROUPS OF FIVE WASHERS SURROUNDING THE TIP OF AN ENDOSCOPE AND THE PROFILE OF THE CAM USED TO DRIVE ONE SET OF WASHERS. FROM ALLRED'S 1994 PATENT	42
2.8	THE FOUR LEGGED ENDOSCOPE FROM TREAT'S 1997 PATENT.	43
2.9	A BORESCOPE PROPELLED BY A JET AT ITS TIP FROM GINSBURGH'S 1988 PATENT.	44
2.10	CROSS SECTION AND SIDE VIEWS OF AN ENDOSCOPE WITH BELTS TO PULL IT ALONG THE BOWEL.	45
2.11	AN EVERTED TUBE IS USED TO PULL A FIBRESCOPE THROUGH A CONDUIT. FROM MASUDA'S 1978 PATENT.	46
2.12	AN ENDOSCOPE IS RATCHETED INTO THE COLON WHILE ITS TIP SHUFFLES BACK AND FORTH. FROM NAGEL'S 1978 PATENT.	50
3.1a	THE HANDGRIP BEING CLOSED AROUND AN ENDOSCOPE.	52
3.1b	DRAWING OF THE HANDGRIP.	52
3.2	BLOCK DIAGRAM OF THE ANALOGUE CIRCUIT.	55
3.3	CALIBRATION RESULTS.	56
3.4	FORCES EXERTED WHILE INSERTING A COLONOSCOPE INTO A 40 YEAR OLD MAN WITH IRRITABLE BOWEL AND A FAMILY HISTORY OF COLORECTAL CANCER.	59
3.5	FORCES EXERTED WHILE INSERTING A COLONOSCOPE INTO A FORTY YEAR OLD MALE WITH RECTAL BLEEDING	60
4.1	WATER IS PUMPED UP A 3.2 MM OD TUBE TO A HEAD WITH THREE DOWNWARD FACING HOLES. THE FORCE FROM THE JETS ENABLES IT TO PERFORM THE "INDIAN ROPE TRICK" INSIDE AN ACRYLIC TUBE.	67
4.2	WATER IS TURNED AROUND AND ACCELERATED OUT THROUGH A NOZZLE.	68
4.3	THE 'VENA CONTRACTA'.	68
4.4	WATER BEING DRIVEN THROUGH AN ORIFICE.	69
4.5	APPARATUS USED TO MEASURE THE THRUST PRODUCED FOR A GIVEN FLOW RATE AND PRESSURE.	70
4.6	LEFT; COMPRESSED GAS USED TO PRESSURISE THE WATER RIGHT; PISTON PUMP AND NEEDLE VALVE USED TO GENERATE PRESSURE.	71
4.7	SPRAY HEAD ATTACHED TO A HOSE.	73
4.8	THRUST, PRESSURE AND FLOW FOR THREE DIFFERENT CROSS SECTIONAL AREAS OF NOZZLE.	76
4.9	THE HIGH PRESSURE OVERTUBE.	79
4.10	DUAL CHANNEL ENDOSCOPE WITH ACRYLIC AND ALUMINIUM HEAD.	80
4.11	DUAL CHANNEL ENDOSCOPE AND HEAD WITH ALUMINIUM SKIN AND CORE	81
4.12	ACRYLIC HEAD WITH TWO EXTERNAL SUPPLY TUBES. THE PHOTO SHOWS A PAEDIATRIC ENDOSCOPE BEING PULLED VERTICALLY UPWARDS.	83
4.13	ACRYLIC HEAD INCORPORATING A MECHANICAL CLAMPING AND SPRAY CONES.	84
4.14	THE QUESTION MARK MODEL COLON.	85
4.15	THE COLON REPRESENTED AS A TUBE WITH CLOSED ENDS.	88
4.16	A JET OF WATER STRIKING A MEMBRANE PERPENDICULARLY.	91
4.17	MEMBRANE HOLDER.	93
4.18	PHOTO OF A 0.5 MM WATER JET STRIKING A RUBBER MEMBRANE.	95
4.19	THE BRAKE UP OF A JET SPRAY.	98
4.20	A FAILED DESIGN FOR AN ANNULAR JET NOZZLE.	99
4.21	A JET SWIRL ATOMISER	99
4.22	ATOMISER WITH COLLIDING JETS.	99
4.23	STREAMS COLLIDING AT (A) SEVERAL M/S, (B) 20 M/S AND (C) VERY HIGH SPEED.	100

4.24	SHEETS PRODUCED BY JETS IMPINGING AT VARIOUS ANGLES.	100
4.25	DRAWING OF NOZZLE WITH AFTER-NOZZLE ATTACHED.	102
4.26	PROTOTYPE JET PROPULSION HEAD WITH ATOMISING NOZZLES.	105
5.1	A SUCTION CRAWLER MOUNTED ONTO AN ENDOSCOPE	107
5.2	SCHEMATIC DRAWING OF A SUCTION CRAWLER USING BELLOWS.	108
5.3	BEAM BENDING	110
5.4	THE SUCTION CRAWLER FROM DARIO ET AL.	114
5.5	EQUIPMENT TO MEASURE THE STRENGTH OF ATTACHMENT ACHIEVED BY VARIOUS DESIGNS OF SUCTION HEADS	115
5.6	THE EXTENT TO WHICH COLON IS SUCKED DOWN INTO A HOLE AFFECTS THE EASE WITH WHICH IT PEELS OFF THE HOLE	116
5.7	THE EXTENT TO WHICH COLON IS SUCKED DOWN INTO A HOLE AFFECTS THE EASE WITH WHICH IT PEELS OFF THE HOLE	117
5.8	THE BOWEL WALL CONTRACTS AS MUCH AS THE BELLOWS SO THAT NO PROGRESS IS MADE	118
5.9	THE STEEL TOOL USED TO MAKE THE FORM FOR THE BELLOWS	119
5.10	THE COMPLETED BELLOWS FOR A SUCTION CRAWLER.	120
5.11	THREE SUCTION CRAWLERS USING BELLOWS. CHRONOLOGICALLY THE SMALLEST WAS MADE FIRST, THEN THE MID SIZE AND FINALLY THE LARGEST. IT CAN BE SEEN THAT THE TECHNIQUE FOR RUBBER CASTING IMPROVED WITH TIME.	121
5.12	DRAWING OF THE SHORTEST BELLOWS DRIVEN SUCTION CRAWLER	122
5.13	WHEN SUCTION IS APPLIED TO THE INSIDE OF THE BELLOWS IT DRAWS THE ROLLING DIAPHRAGM ONTO THE INSIDE OF THE BELLOWS AND COLLAPSES THE ROLLING AREA. BOTH EFFECTS STOP THE 'ROLLING SEAL' FROM ROLLING.	125
5.14	A PAIR OF BACK-TO-BACK BELLOWS INTENDED TO MOVE A MIDDLE SECTION	126
5.14	FIGURE 5.14ps FIGURES REPRODUCED FROM THE 1961 PATENT "PERFECTIONNEMENTS AUX CATHÉTERS MÉDICAUX". <i>ps</i>	127
5.15	A CABLE DRIVEN SUCTION CRAWLER MOUNTED ONTO A PAEDIATRIC ENDOSCOPE	128
5.16	SCHEMATIC DIAGRAM OF THE VALVE UNIT	131
5.17	AN EARLY PROTOTYPE CABLE DRIVEN SUCTION CRAWLER.	131
5.18	SECOND GENERATION SUCTION CRAWLER.THE NOSE AND TAIL PIECES FOR AN ENDOSCOPE MOUNTED SUCTION CRAWLER WITH REAR FACING PORTS	132
5.19	THIRD GENERATION SUCTION CRAWLER WITH RADIAL SUCTION PORTS.THE LEFT HAND HALF OF THE DRAWING SHOWS THE NOSE PIECE, THE RIGHT HAND HALF SHOWS THE TAIL PIECE.	134
5.20	DETAIL FROM FIGURE 5.1 SHOWING THE SUCTION TUBE FOR THE FRONT FOOT PASSING THROUGH THE REAR FOOT	135
6.1	A DEVICE THAT PROPELS ITSELF FORWARD BY ELECTRICALLY STIMULATING CONTRACTIONS OF THE GUT.	141
6.2	THE MEDICAL MAGNETO STIMULATOR.	142
6.3	DIAGRAM OF MEDICAL MAGNETO.	143
6.4	THE RISE AND FALL OF THE ACTION POTENTIAL RESULTS FROM SODIUM IONS FLOWING INTO THE CELL FOLLOWED BY POTASSIUM IONS FLOWING OUT	146
6.5	THE CONTRACTILE ELEMENTS OF A SMOOTH MUSCLE CELL.	147
6.6	THE MYOSIN WHALE.	148
6.7	SKETCH SHOWING THE POSITIONS OF THE ELECTRODES AND STRAIN GAUGES ATTACHED TO RABBIT COLONS BY RATANI ET AL.	151
6.8	THE CONFIGURATION USED BY GRUNDFEST-BRONIATOWSKI ET AL TO STUDY	152

	COORDINATED ELECTRICAL STIMULATION OF AN ILEAL POUCH.	
6.9	DEVICES FOR STIMULATING CONTRACTIONS OF THE COLON	155
6.10	DEVICE E1.	156
6.11	DEVICES E2 ON THE LEFT AND E3 ON THE RIGHT	157
7.1	METHODS OF ATTACHING HYDROPHILIC POLYMERS TO HYDROPHOBIC SUBSTRATES. AN INTERPENETRATING NETWORK (ABOVE) AND GRAFTING (BELOW).	171
7.2	"MOLECULAR CILIA" PROVIDE LUBRICATION.	171
7.3	CHANGE IN MAXIMAL RESISTANCE FORCE FOR A STEEL TUBE DIPPED IN OLIVE OIL (O) OR COATED WITH HYDROGEL (Δ). BARS SHOW STANDARD DEVIATIONS.	172
7.4	SALES LITERATURE GRAPH FROM AST (BILLERICA, MA, USA) COMPARING LUBRICIOUS HYDROGELS TO PE AND PET.	173
7.5	SALES GRAPH FROM STS BIOPOLYMERS	173
7.6	A WEIGHT ON A SURFACE.	177
7.7	THE RIG AND THE TOBOGGAN USED TO MEASURE THE COEFFICIENT OF FRICTION BETWEEN AN ENDOSCOPE AND EXCISED COLON.	179
7.8	THE TOBOGGAN, WITH TISSUE CLAMPED ONTO IT, RESTS ON RAILS MADE FROM HYDROGEL COATED CATHETERS WITH STEEL RODS RUNNING THROUGH THEM.	181
7.9	PORTION OF THE CATHETER IN CONTACT WITH TISSUE.	182
7.10	MEASUREMENTS OF THE STATIC COEFFICIENT OF FRICTION BETWEEN EXCISED PORCINE COLON AND AN ENDOSCOPE OR HYDROGEL COATED CATHETER.	184
7.11	MEASUREMENTS OF THE DYNAMIC COEFFICIENT OF FRICTION BETWEEN EXCISED PORCINE COLON AND AN ENDOSCOPE OR HYDROGEL COATED CATHETER.	185
7.12	NYLON SLEEVES AND SILICONE RUBBER BANDS WITH AN ENDOSCOPE.	189
8.1	WATER JETTING OUT OF THE SPRAY HEAD LIFTS AN ENDOSCOPE VERTICALLY UPWARDS.	192
8.2	SUCTION CRAWLER ATTACHED TO AN ENDOSCOPE. THE SUCTION FEET CAN BE MOVED TOGETHER AND APART WITH A BOWDEN CABLE.	193
8.3	ELECTRODES STIMULATE THE MUSCLES IN THE GUT WALL TO CONTRACT, SQUEEZING THE LOZENGE SHAPED DEVICE FORWARD.	194
8.4	A SLEEVE COATED WITH A LUBRICATING HYDROGEL IS ATTACHED TO AN ENDOSCOPE.	195
A1	THE '?' MODEL COLON	199
A2	A SKETCH OF THE PIG COLON.	202
A3	SUCTION CRAWLER IN COLON.	203
A4	SCHEMATIC DIAGRAM OF MODEL COLON USING NYLON STOCKING TO CONTAIN EXCISED PORCINE COLON.	204
A5	PHOTOGRAPH OF THE MODEL IN USE	204
A6	COMPONENT AND ASSEMBLY DRAWINGS FOR THE RADIUS CLAMPS	205

1 Introduction.

1.1 The need for improvements to the method of inserting colonoscopes.

During the last 25 years, colonoscopy has become an increasingly common diagnostic procedure. It produces very high quality images of the colon, allows biopsy samples to be collected and provides a means by which minimally invasive surgical procedures can be performed. Colonoscopy is the preferred method for investigating rectal bleeding, a frequent symptom of bowel cancer.

Colorectal cancer and polyps are the commonest diseases requiring investigation by colonoscopy but there are other diseases such as inflammatory bowel disease, infectious colitis, unexplained chronic diarrhoea, diverticular disease and bleeding vascular abnormalities that may be diagnosed by colonoscopy.

However there are problems with colonoscopy which include considerable discomfort for the patient and the technical difficulty which means that, even with a highly skilled practitioner, it usually takes ten to fifteen minutes to fully insert the colonoscope and then it is not always possible to examine the whole length of the colon. The reason for this difficulty is that the colon is an elastic tube that follows a tortuous path. As the colonoscope is pushed around a bend it does not always slide smoothly along the colon wall but frequently catches on it so that as the colonoscope is pushed further in, the colon is stretched and a loop is formed¹. The temptation is then to push harder to try to force the tip of the endoscope to advance, but doing this enlarges the loop and increases the stress on the bowel wall, "A classic scenario is the sigmoid colon tear resulting from excessive force applied to overcome looping"².

There are a number of factors such as adhesions from previous pelvic diseases or operations which predispose the colon to perforate³. Other significant factors include the presence of diverticular disease, colonic dilatation due to inflammatory conditions such as colitis, mechanical obstruction such as volvulus or myopathic changes due to pseudo-obstruction⁴.

Habr-Gama and Waye in 1989⁵ surveyed results from 8 papers and found that even when the colonoscopy was purely diagnostic, without any therapeutic intervention, the colon

was perforated in 0.17% of cases, with the frequency of perforation ranging from a low of 0.06%⁶ to a high, from a relatively early 1979 study, of 0.57%⁷. Damore et al⁸ report similar statistics in their more recent, 1996, paper which reports perforation rates for diagnostic colonoscopy ranging from 0.03% to 0.65%. Cotton and Williams report that at St. Mark's hospital there have been no significant complications during the last 20,000 examinations and rather uncharitably go on to say that this "is not representative of what may be happening in the hands of unskilled endoscopists needing to use heavy sedation to cover up for their ineptitude."⁹

Overall a mortality rate of one in 1,700 is associated with colonoscopy¹⁰ and, at least in 1984, complication rates of 2% for diagnostic procedures and 5% for polypectomy¹¹.

1.2 The requirement for colonoscopy

1.2.1 Colorectal Cancer.

For those who live in the industrial West and do not smoke the most usual site for a fatal cancer is the bowel. In the UK there are about 25,000 new cases per year which cause about 17,000 deaths per year. In percentage terms this corresponds to 5% of the population getting bowel cancer at some time and about 3% dying from it¹². In the USA the lifetime risk is about 7% and the survival rate is a little under 50% at five years and has not changed in several decades¹³.

The incidence of cancer increases dramatically as one moves along the bowel. The "small" bowel accounts for the first four fifths of the total bowel but only gives rise to a small fraction of bowel cancers. The overwhelming majority of cancers are located in the colon and the rectum and it can be seen (Table 1.1 and Figure 1.1) that it is the last few centimetres that account for more than three quarters of all bowel cancers. From here on "bowel cancer" will be used as a synonym for "colorectal cancer".

Site of cancer	%
Caecum and appendix	6
Ascending colon	3
Hepatic flexure	2
Transverse colon	5
Splenic flexure	3
Descending colon	3
Sigmoid colon	21
Rectum	57
Total	100

Table 1.1. Distribution of Bowel Cancer by Site. (Northover, 1992)¹⁴

If it was practical to screen for bowel cancer many lives could be saved as, apart from being frequent among older people, it is usually slow growing and if caught early has a good cure rate. Table 1.2 contains results from a study at St. Marks Hospital which shows high five year survival rates for rectal cancers caught early in their life cycle. Figure 1.1 reproduces a graph of similar data from St Vincent's Hospital which also shows very good survival rates for early stage cancers.

Dukes stage	Degree of spread	Lymph glands effected	5 year survival
A	Contained within the bowel	None	97%
B	Through the bowel wall	None	81%
C1	Any degree of local spread	Cancer present but not in highest gland	51%
C2	Any degree of local spread	Cancer present in highest gland	23%

Table 1.2 (Northover, 1992)¹⁵

Survival rates among patients with rectal cancer at St Mark's Hospital. In all cases the surgeon had attempted to cure the cancer by removing all visible and known cancer.

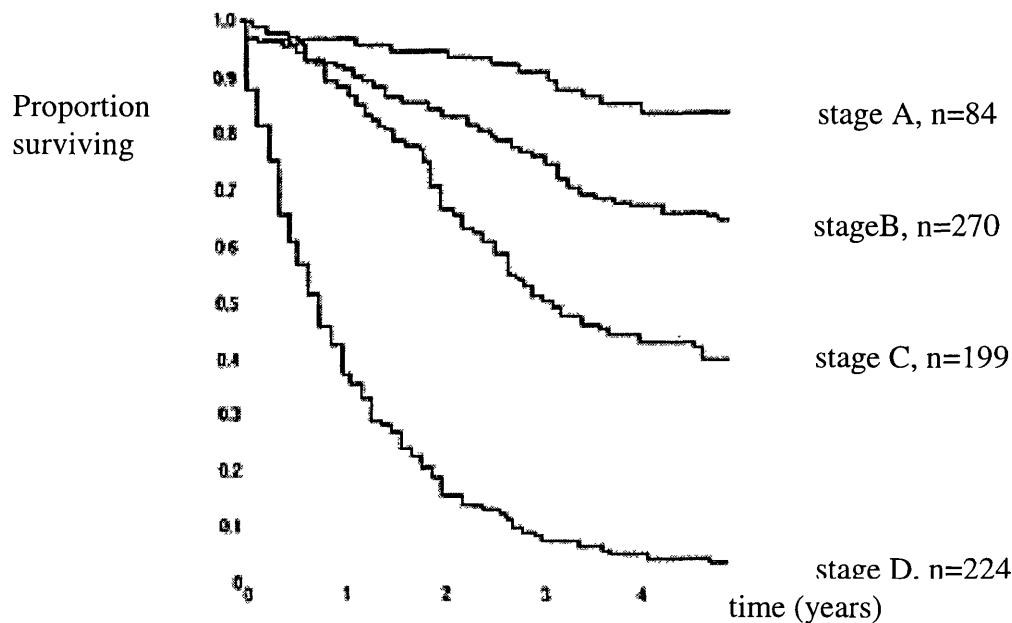


Figure 1.1 Survival of 777 consecutive patients with colorectal cancer stratified by tumour stage. (Reproduced from Mulcahy 1997)¹⁶

Although widespread screening is desirable, there is currently no satisfactory method of performing it. In the following quotation from the chapter ‘Cancer Surveillance Strategies’ in ‘Gastro Intestinal Disease: Pathophysiology, Diagnosis’ Luk¹⁷ lists five alternative approaches to screening and the problems with them; ~

Faecal occult blood test (FOBT); low specificity and low sensitivity, but cheap and entirely hazard free.

Biomarkers, carcinoembryonic antigen; worse than occult blood test.

Colonoscopy; sensitive and specific but risk of complications, expensive and requires colon “preparation” by, for example, drinking four litres of polyethylene glycol balanced electrolyte solution,

Proctosigmoidoscopy; Quicker and easier than colonoscopy but about a quarter of tumours lie beyond the sigmoid colon.

Barium enema; Sensitivity quite good but not as good as endoscopy. Does not allow biopsy.

The lack of a really satisfactory test leads to considerable confusion about who should be screened and when. Mulcahy et al review the situation in their article ‘Screening for Asymptomatic Colorectal Cancer’ (1997)¹⁸ and conclude that most cancers strike the

general population and there seems to be little agreement about the worth of screening the general population, although there are some groups with a known high risk such as those with two first degree relatives affected who have a 1 in 3 lifetime risk of colorectal cancer. They report that the American Cancer Society recommends annual FOBT and digital rectal examination from the age of forty and three yearly sigmoidoscopy from fifty, but that the Kings fund and the Canadian Task Force for Periodic Health Examination do not recommend mass screening.

Significant improvement in the ease and cost of endoscopy would help with all forms of screening as the poor specificity of the tests make endoscopy a frequently needed follow up procedure. Colonoscopy currently costs about \$600 per patient and this helps deter governments and insurers from recommending screening. According to Mulcahy, Lieberman¹⁹ estimates the cost per life saved at between \$225,000 and \$280,000 with 100% compliance at all stages of the follow up to an initial positive result, rising to \$350,000 with only 50% of the population complying. These figures include the cost of cancer treatment and are presumably for a rather expensive surveillance regime; they contrast with the estimate from Aitken²⁰ (also referenced in Mulcahy) that a single flexible sigmoidoscopy at age 55-60 would cost £8,500 per cancer death prevented.

In any event we may conclude that reducing the difficulty of colonoscopy would enable increased use of colorectal screening and that this would save lives.

1.2.2 Other Indications for colonoscopy.

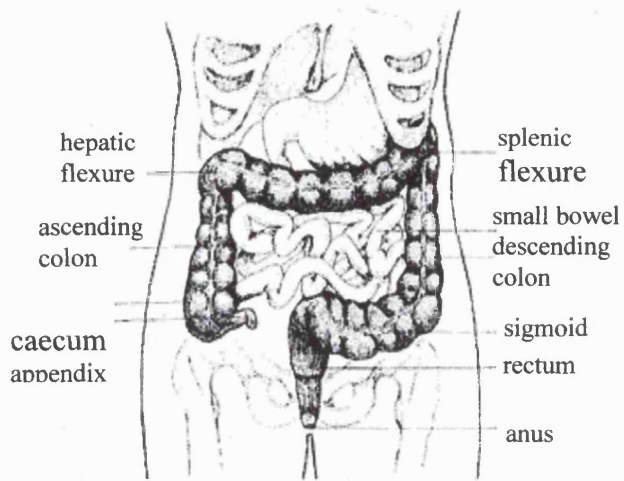
The suspicion of colorectal cancer is not the only indication for colonoscopy, although it is much the most important. Waye²¹, writing in Bockus's Gastroenterology, lists three other indications; unexplained chronic diarrhoea, infectious colitis (which usually does not require colonoscopy) and inflammatory bowel disease (where colonoscopy is not usually required but can be useful for distinguishing between types of disease, in particular Crohn's disease and ulcerative colitis. There is also a considerable increase in the risk of carcinoma among these patients). Naitove and Smith²² add diverticular disease to this list, pointing out that although diverticula (hernias in the wall of the colon) rarely

present symptoms, they are found in a third to a half of Westerners over the age of sixty. Bleeding vascular abnormalities could also be added to this list.

1.3 Anatomy of the colon and rectum.

The detailed anatomy of the colon is, like all organs, enormously complicated. From the point of view of this thesis all that matters is what relates to advancing a colonoscope, which more or less comes down to a description of the colon as a long, tortuous, floppy, loosely attached but reasonably wide and well lubricated tube that is cushioned against various other organs.

Figures 1.2 shows schematic anterior/posterior and lateral views as well as reproducing a relatively naturalistic illustration from Grant's Atlas of Anatomy. In practice the large bowel is frequently more convoluted and pushing the scope into the bowel may form loops. Figure 1.3 contrasts a radiograph²⁶ of a normal colon with one where the colonoscope has become looped²³.

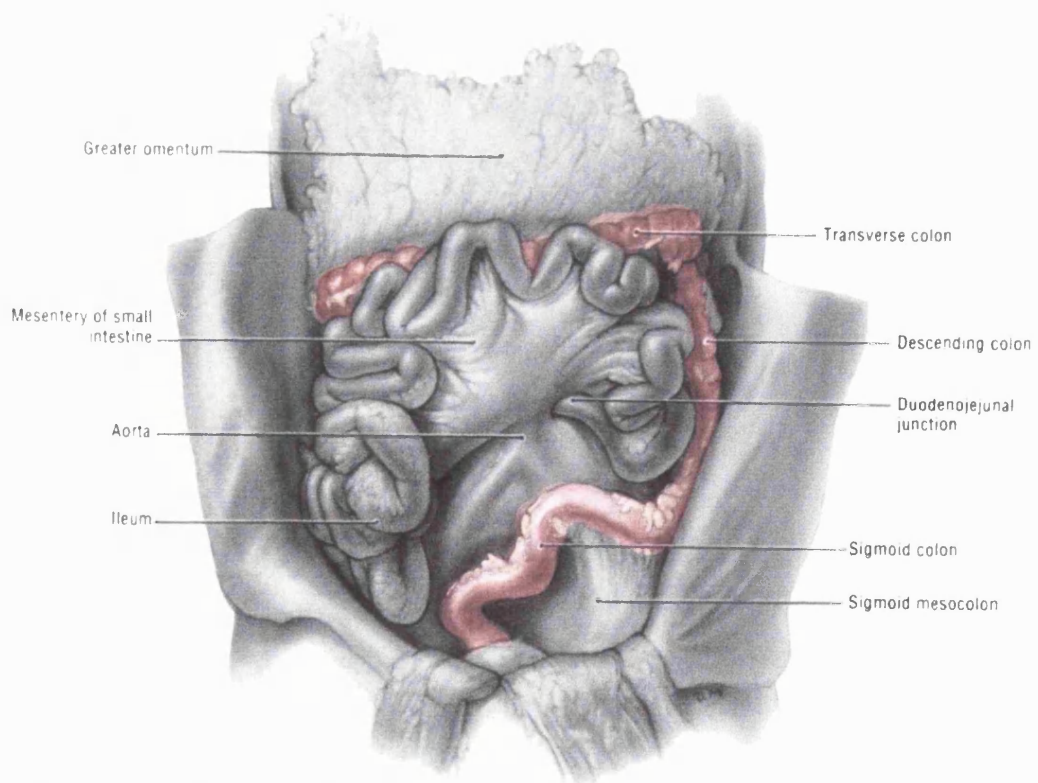


A/P View



Lateral View

'A' is the anatomic splenic flexure
'B' is the radiographic splenic flexure



Reproduced from Northover²⁴ (A/P view), Haubrich²⁵ (lateral view) and Grant's Anatomy²⁶

Figure 1.2 Schematic and naturalistic drawings of the colon.

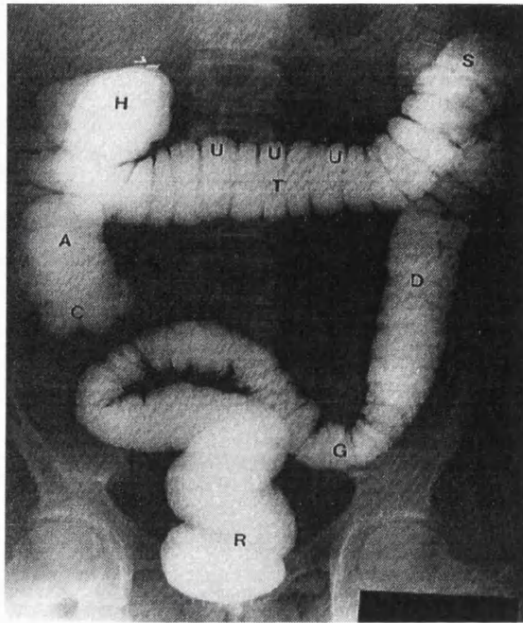


Figure 1.3 a. Barium enema X-ray
 C = caecum, H = hepatic flexure
 U = haustra, S = splenic flexure
 G = sigmoid, R = rectum
 A&D = ascending and descending colon
 (from Grants Atlas of Anatomy, 1991)

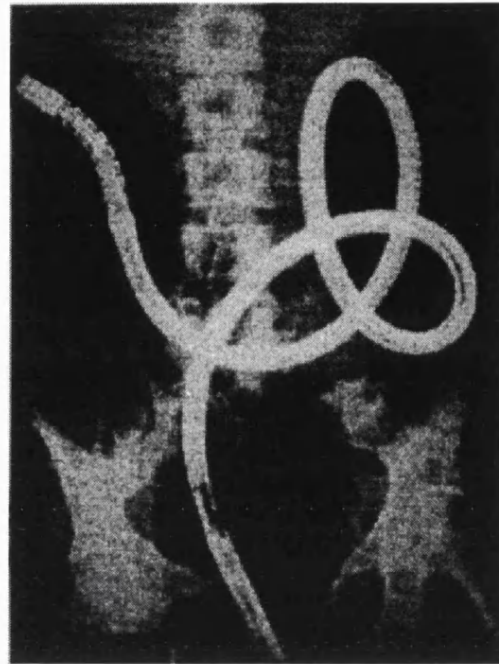


Figure 1.3 b. X-ray showing a colonoscope that has become looped.
 (From Hunt, 1981)

The length of the large bowel is very variable. In adults it is about 1.5 m long²⁷ when extended but as it is normally convoluted only about 1 m of colonoscope has to be inserted through the anus to reach the caecum once loops have been removed. The diameter of the colon gradually tapers from about 8 cm at the caecum to about 2.5 cm at the sigmoid section²⁸. As can be seen in the illustrations, the colon is usually made out of a series of pouches (“haustra”) which are demarcated by strands of circular muscle. They are almost always present in the transverse colon where they are particularly large.

The wall of the colon is about 3-4 mm thick²⁹ and has four layers: the mucosa, the submucosa, the muscle coat and the serosa. The mucosa is covered by a single layer of epithelial cells among which are many goblet cells that produce copious mucus. The outer layer is thicker and stronger and contains the muscles that generate peristalsis.

The ease of colonoscopy depends considerably on how free the colon is to move and how rigidly it is attached to the posterior abdominal walls. In some places it is fused to the abdominal walls, but in others it is loosely attached by folds of tissue called mesenteries.

There follows a table of the parts of the large bowel and their attachments, the lengths given for the various parts should be regarded as a very rough guide since the colon can stretch or contract as the muscle tone varies. During colonoscopy the colon is stretched and sometimes it is necessary to insert the entire 1.6 m of the colonoscope into the patient while inserting the instrument although only about 0.8 m is needed to reach the caecum once the endoscopist has “straightened out” the instrument.

Name	Length (mm)	Attachment
Caecum	65	Has no true mesentery and is normally quite mobile. Unusually it is fused to the posterior peritoneum.
Ascending colon	200	Almost always retroperitoneally fixed to the posterior abdominal wall (but see Saunders below).
Hepatic flexure		
Transverse colon	400 - 500	The most mobile segment, enveloped in the folds of the transverse mesocolon that loosely connect it with the peritoneum.
Splenic flexure		Firmly attached to the diaphragm
Descending colon	300	Usually “applied” closely to the posterior abdominal wall.
Sigmoid	150 - 500	Almost always has a generous mesentery which permits much mobility.
Rectum	150	Well attached at the anus and supported by the sacrum.

Table 1.3 Lengths and attachments of parts of the large bowel
(Derived from Haubrich, 1995³⁰)

Within the population there are wide variations in colonic anatomy. Saunders³¹ ascribes much of this variability to the embryology of the colon. As the colon develops rapidly during the second month of gestation it becomes too large for the abdominal cavity and spills into the umbilical cord. The colon slowly returns to the abdomen with the caecum being the last part to return to the cavity where it migrates from the upper right quadrant to its final position. When the gut returns, its mesenteries are pressed against the posterior abdominal wall and normally the mesenteries of the ascending colon, descending colon and rectum fuse with the parietal peritoneum of the abdominal wall. However, the mesenteries of the transverse and sigmoid sections do not fuse completely and these parts remain suspended on their mesocolons.

The extent to which this fusion occurs can vary considerably and Saunders reports a study by Sir Frederick Treves³² in which he found that of 100 cadavers 52 had firmly attached ascending and descending colons, 22 only had the ascending colon firmly attached, 12 only had the descending colon firmly attached and 14 had both ascending and descending colons held by mesenteries. Apparently, Treves comments that the ascending mesocolon is typically one or two inches long while the descending mesocolon is about one to three inches. (Incidentally, Saunders says that this 1885 study of colonic attachments is the most recent in the English language.)

1.4 The Colonoscope

Since before the beginning of recorded time men and women have stared up each others bowels with the aid of whatever tubular tools came to hand; however Hippocrates was the first to publish when in 440 BC he used a bi-valved vaginal speculum to examine the anus and distal rectum (Milne 1907³³). Viewing beyond the rectum into the further reaches of the colon needed very much more sophistication and it was only in the last few decades that endoscopes developed sufficiently to become colonoscopes. In his 1995 book 'Endoscopy of the Colon, Rectum and Anus' Church uses a table to summarise the history of colonoscopy and Table 1.4 is a copy of this. Church derived this table from Edmonson's excellent thirty page article 'History of instruments for GI endoscopy',³⁴ and much of the rest of this section is a summary of parts of that article with references only being given for direct quotations from the article.

440 BC	Hippocrates describes anal speculum
AD 79	Anal speculum [ceases being] used in Pompei
1806	Bonzini describes “licht leiter”
1894	Kelly reports a rigid 30 cm “sigmoidoscope” with reflected light as illumination
1903	Tuttle uses electric light for rigid sigmoidoscope
1954	Hirschowitz incorporates fiberoptics into fibrescope
1957	Hirschowitz gastroscopes himself, then patient- the first fiberoptic examinations
1957	Hirschowitz demonstrates “fiberscope” to American Gastroscopic Society
1963	Turel uses modified ACMI gastroscopes to view colon
1965	Provenzale and Revignas pull a gastroscopes through a colon with a plastic tube
1965	First fiberoptic sigmoidoscopes and colonoscopes produced in Japan and the US
1967	Overholt reports first series of fiberoptic sigmoidoscopy
1969	Overholt reports use of Olympus CF-SB colonoscope
1969	Wolff and Shinya establish colonoscopy at Beth Israel Hospital, New York
1970	Olympus CF-MP/LB introduces four way tip deflection
1971	Wolff and Shinya begin endoscopic polypectomy
1973	Williams hot biopsies small polyps
1983	First video-endoscope introduced by Welch-Allyn, New York
1983	Sivak and Fleischer report preliminary experience with video-endoscope

Table 1.4 A summary of the history of lower GI endoscopy
(from Church 1995³⁵)

1.4.1 Rigid Endoscopy

There was little progress in endoscopes until between 1803 and 1806 Bonzini developed the “Lichtleiter”, or “light conductor”. This used a light source (candle), a reflective surface and a tubular speculum to illuminate the tissues under examination and is generally held to be the first true endoscope. Bonzini used the instrument to view the rectum but it was never a practical device and despite his seminal importance Bonzini was discredited and died of typhus in 1809.

Pierre Segalas in Paris and John Fisher in America improved the design and produced somewhat more practical instruments. Fisher’s original motivation for developing an endoscope was prompted by “a woman who had a disease at the neck of the uterus, and so great were her feelings of delicacy that I could not prevail upon her to suffer me to make

an examination with a common speculum.”³⁶ His technical innovation was to add a lens to enlarge the image.

By 1868 endoscopy had proceeded far enough that Adolf Kaussmaul could produce the first rigid gastroscope which he demonstrated to the Society of Naturalists of Freiburg with the aid of a co-operative sword swallower. Once again the instrument was seminal but not practical. The problem was not so much that it was rigid and straight, as that the light source which burnt a mixture of alcohol and turpentine was too dim. Further significant progress had to await the development of electric light and in particular Edison’s invention of the light bulb in 1879.

In 1895 Kelly reported on a rigid one foot long sigmoidoscope that used reflected light and a few years later Tuttle added a tiny light bulb which in turn was superseded when the Welch-Allyn company introduced fibreoptic light guides to carry illumination to the very front of the scope (both referenced in Church 1995^{37, 38}). Reusable and disposable rigid proctoscopes are still in routine use.

1.4.2 Semi-flexible endoscopy

The semi-flexible endoscope forms the next era in the history of endoscopy. This was a major development but from the point of view of colonoscopy full flexibility was required and we will devote only a little space to its development.

Endoscopes based on mirrors had to be rigid during use. A number of instrument makers produced endoscopes that were flexible during insertion, but they all had to be made rigid once in place. This temporary flexibility was not an advantage and in 1911 Elsner reintroduced the rigid endoscope and produced a practical instrument that, in the words of Schindler, the leading endoscopist of the time, “remained the mother of all instruments until 1932”. Despite his proficiency in its use Schindler still had problems and wrote “Death from a diagnostic method is a severe setback to a procedure. It seemed however that such a useful and perhaps necessary method should not be discarded because of an occasional fatality but should be developed to a point where it is entirely safe”³⁹.

Working with the instrument maker Georg Wolf, Schindler found “that a tube filled with very thick lenses, with a short focal distance, could be bent in several planes to an angle of about 34° without distortion of the image”⁴⁰. They made the distal half of the scope flexible by using a strip of bronze wound into a spiral and covered by a rubber tube. With this development and the subsequent addition of a biopsy channel and a steerable tip, gastroscopy finally became a central part of gastrointestinal medicine.

1.4.3 Flexible Colonoscopes

Attempts were made to use semi-flexible endoscopes for colonoscopy and in 1957 Matsunaga and colleagues in Japan found that with an Olympus gastrocamera they could reach the transverse colon in 24% of cases⁴¹. This success rate was unacceptable and showed that the colon required a system that could guide an image around a tortuous route without severe distortion or loss of brightness. This was initially achieved by using flexible fibre-optic image guides and more recently by placing an extremely small video camera at the tip of the scope. That it was possible to pass a flexible tube through the colon had been demonstrated as early as 1927 when a radiologist named Hoff described a method of intubation using a five foot rubber hose attached to an enema can. Hoff acknowledged that the procedure had no real therapeutic value (at least for the patient)⁴².

In 1952 work started independently in England and Holland on the use of flexible glass fibres for light transmission. A few years later Hirchowitz and fellow workers at the University of Michigan heard of this and set about producing a coherently organised bundle of fibres so that an image projected onto one end of the bundle would be reproduced at the other end. Despite having a budget of less than \$3,000 for the two year project Hirchowitz was able by early 1957 to push the first fully flexible gastroscope down his own throat⁴³. Clinical experience followed and in 1961 Hirschowitz published clinical results in the *Lancet* and was sufficiently confident to write “the conventional gastroscope has become obsolete on all counts”⁴⁴. This optimism proved premature and a 1966 report on 1000 fiberscope examinations concluded that “the duodenum was not entered with certainty in any examination”⁴⁵.

A much reproduced picture of a postage stamp bearing Abraham Lincoln's head shows that by modern standards the image was very grainy with relatively few pixels. This is hardly surprising when one considers that they had to draw their own optical fibres using a porridge tin as a winding drum and that a modern colonoscope image bundle contains up to 42,000 fibres each of 8 - 10 micrometers diameter⁴⁶.

The problem of how to push a flexible endoscope into the colon was taken up by Overholt who was an intern at the University of Michigan in 1961. Overholt⁴⁷ recounts how he went for a job and was interviewed by a man who that very morning had suffered a painful investigation with a rigid sigmoidoscope. Overholt suggested that a flexible instrument would be an improvement and he duly got the job with the American Public Health Service who also provided the funds for developing the flexible colonoscope. By 1963 he was able to use the fibre sigmoidoscope clinically, but it was not until 1967 that he presented the first series of forty patients. The steering system that they developed was remarkably similar to that still in use.

Meanwhile in Japan at least two groups were developing colon fibrescopes. Oshiba and Watanabe working with the Machida Instrument Company produced their first prototype in 1963 while Olympus worked with groups at Tokyo and Hirosaki Universities. After some years Olympus came to dominate the world of colonoscopy which is slightly ironical considering that Japan has a relatively low rate of colorectal cancer and that, according to Saunder's MD thesis,⁴⁸ Oriental colons are on average easier to navigate than Occidental colons.

A major advantage of the colonoscope compared with other imaging modalities was that it allowed the clinician to take biopsy samples by inserting small forceps through a channel provided in the endoscope. In 1969 Shinya and Wolff at Beth Israel used this channel to introduce a wire lasso that could be used to snare a polyps. An electric current could then be used to heat the loop as it was tightened so that the polyp was cut off and the wound cauterised.⁴⁹ Figure 1.4 reproduces pictures from Olympus publicity material that shows a modern snare and a polyp waiting to be snared.

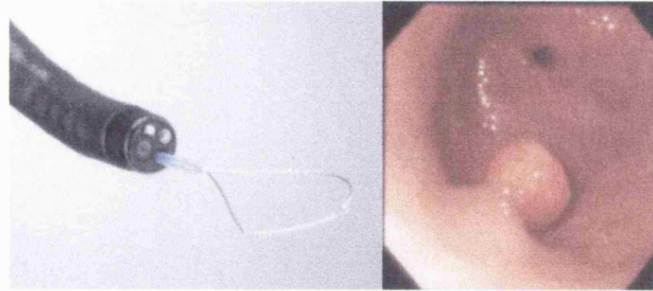


Figure 1.4. A snare and a polyp to be snared
(from Olympus Evis 230 series catalogue)

The history of colonoscopy has consisted of *pushing* ever more sophisticated tubes through the anus and up the colon. Surprisingly the first successful retrograde total colonoscopy used the exactly opposite principle and *pulled* the scope through the colon. In 1965 the Sardinians Provenzale and Revignas⁵⁰ persuaded a patient to swallow a pair of cords arranged as illustrated in Figure 1.5 (actually the cords were thin tubes). Before swallowing commenced the lower cord was threaded through a loop at the end of the upper cord to form a crude pulley. Both cords were then allowed to pass through the gut until the pulley was 30-40 cm proximal to the ileocaecal valve and the two ends of the lower cord were hanging out the anus (see Figure 1.5). One end could then be used to pull a Hirschowitz gastroscope attached to the other end.

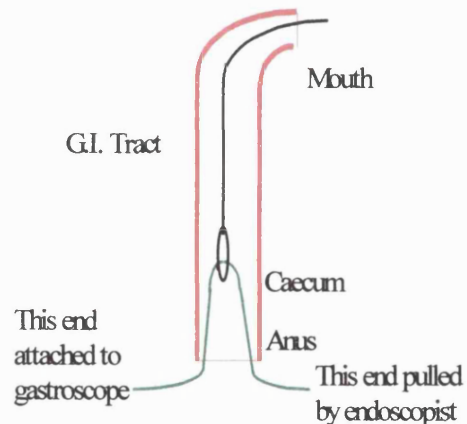


Figure 1.5. Schematic diagram of the pulling system used by Provenzale and Revignas

Having achieved total colonoscopy Provenzale and Revignas abandoned this rather complicated procedure and worked on improving conventional push colonoscopy. From the point of view of this thesis the main interest of their work is that a colonoscope can be pulled through the colon with what must presumably have been a very small traction force.

1.4.4 The modern colonoscope

Photographs of early flexible fibre-optic endoscopes look very similar to modern instruments, but there have been repeated minor improvements in construction and in clinical technique. Writing in 1972 Morrissey⁵¹ reviewed the state of the art and reported that Matsunaga was able to reach the transverse colon in 86% of cases, the ascending colon in 40% and the terminal ileum in 16% using a 1870 mm Olympus CF-LB colonoscope, - an instrument with poly directional tip control. Morrissey quite correctly predicted that “an instrument will probably be developed which can be passed to the terminal ileum in most patients without the use of a guide string.” Today a skilled endoscopist would expect to reach the ileum in the great majority of cases.

The most visible change is that video is replacing fibre optic imaging with the video chip placed at the tip of the scope just behind the lens system. In most colonoscopes used in Britain the resolution is improved by using a monochrome CCD array and sequentially illuminating the colon with red, green and blue light, a processing unit then combines the separate red, green and blue images into a single RGB video picture. Viewing the procedure on a video monitor allows several people, including the patient, to view the image as well as allowing the endoscopist to work in a more comfortable position.

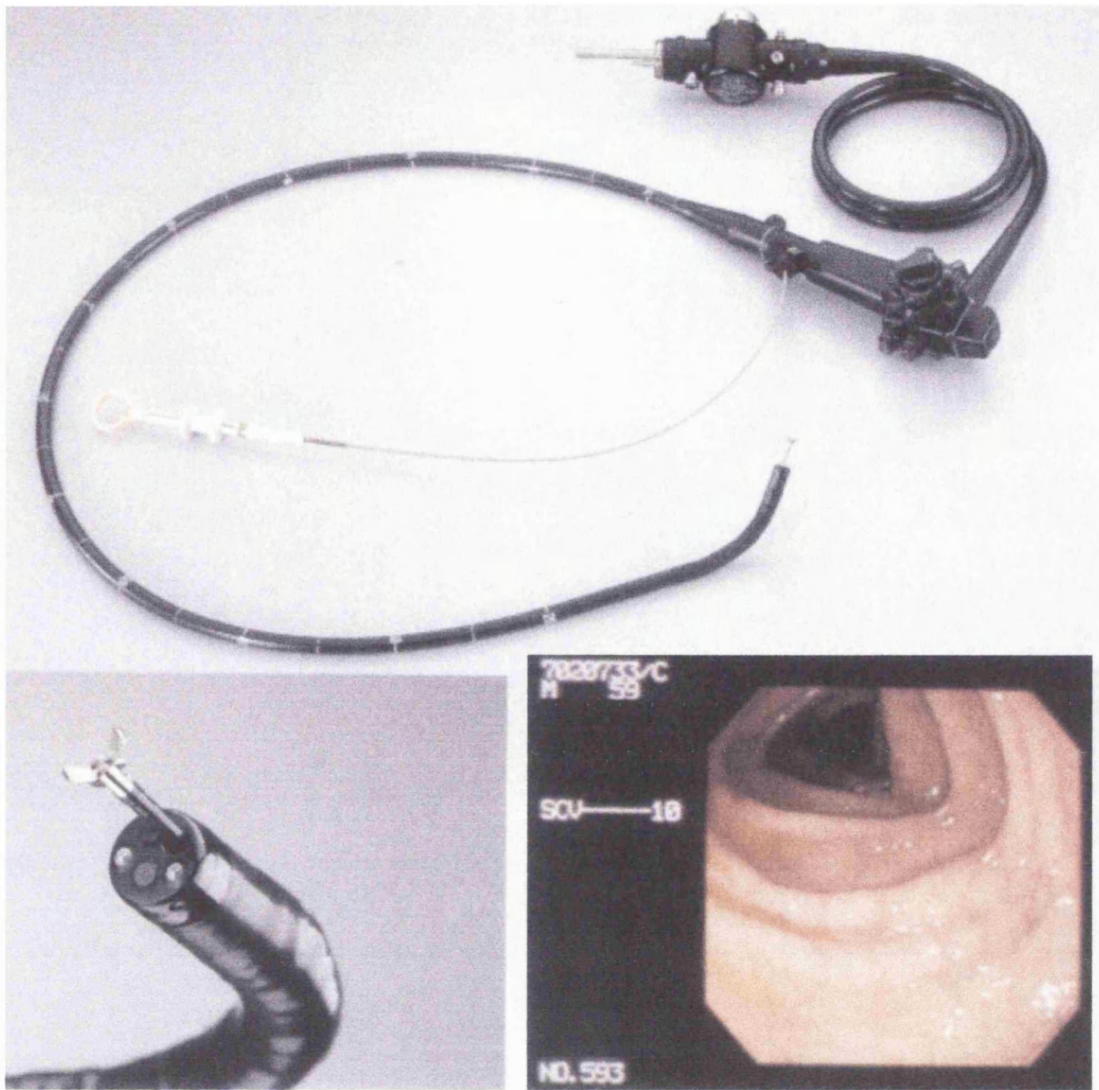
The dimensions of the Olympus PCF 230, a modern and very slim video colonoscope are listed below and Figure 1.6 reproduces a photo from an Olympus brochure of the endoscope with biopsy forceps in place. Figure 1.7 shows the handpiece and shaft from an earlier Olympus endoscope, the 16F-2S, and Figure 1.8 is a copy of a diagram to explain the mechanical and optical workings of a flexible fibre-optic endoscope. It can be seen that although each function is simple in principle, there are a lot of components to fit into the smallest possible space. It is not surprising that the camera manufacturers Olympus and Pentax should have come to dominate the industry.

The steering section of the colonoscope forms the last 10 cm or so before the tip. It consists of a series of universal joints covered by a highly flexible rubber sleeve. Tip

angulation is achieved by two orthogonal pairs of Bowden cables whose outer sheaths are attached to the proximal end of the bending section while the inner wires are attached to the distal end. When one wire is shortened the opposite wire is lengthened so that the tip bends towards the shorter side.

As well as carrying cables, conduits and fibres the body of the scope must not have too little or too much flexibility and must be able to transmit circumferential torque along its length. This is achieved by winding two metal strips helically around the scope. One strip is wound clockwise and one anticlockwise so that as the scope is twisted one tries to expand and the other contract so that they lock up on each other. The Evis PCF 230 varies the stiffness of these helices so that it becomes more flexible as one moves towards the distal end. It remains to be seen whether this extra complexity significantly eases insertion of the colonoscope.

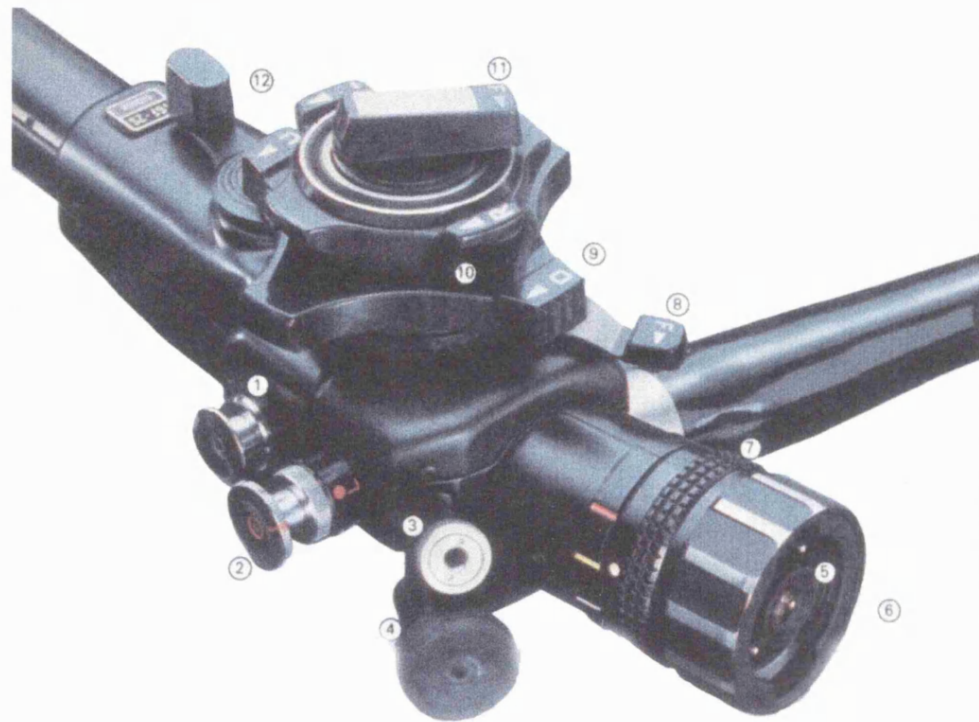
Despite the move to video, the external appearance of the handle has changed little, except that the eyepiece has been removed. This is rather surprising as the handle does not look ergonomically sensible considering that it no longer needs to be held against the operator's eye.



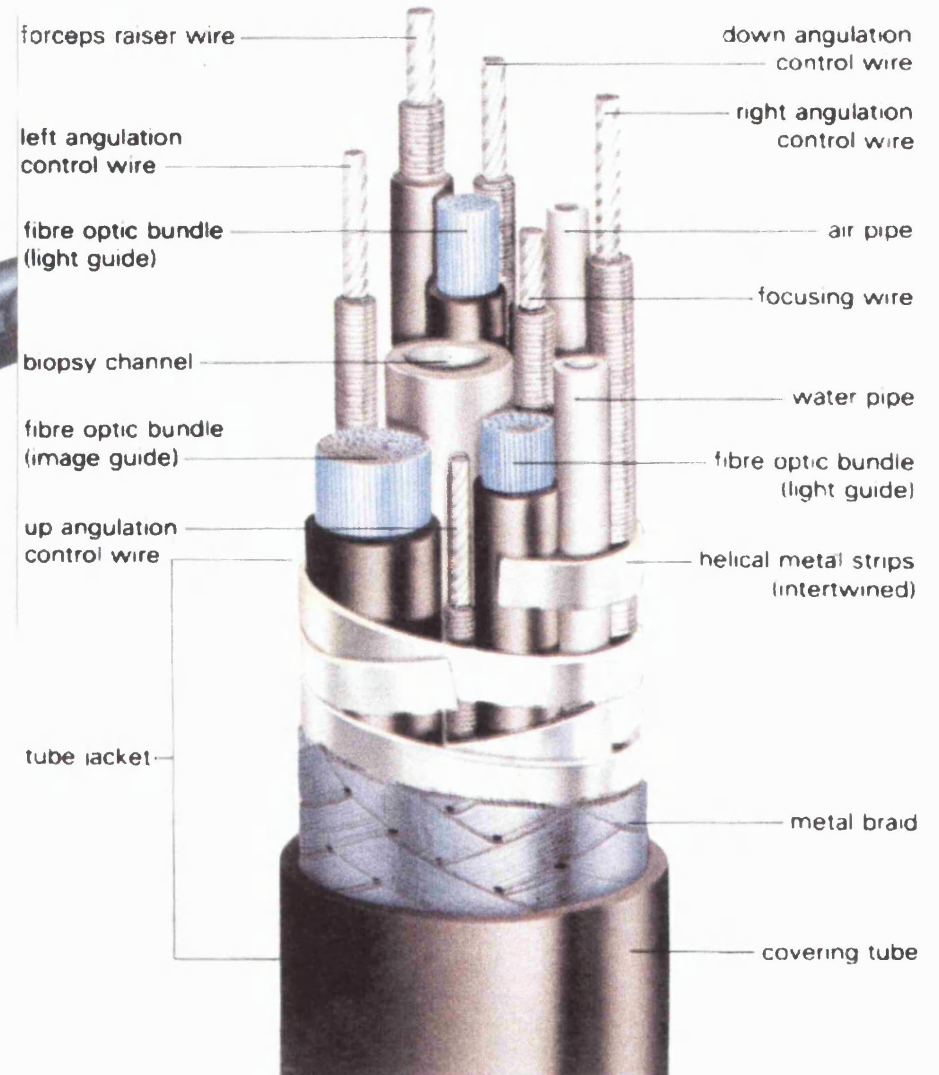
Total length	1625 mm	Working length	1330 mm
Diameter tip	11.2 mm	Instrument channel	2.8 mm (I.D.)
Tip angulation	180° (up/down)	Tip angulation	160° (left/right)
Field of view	140°	Depth of field	4 -100 mm
Cost	about £20,000		

Figure 1.6. The Evis PCF 230 Colonoscope with biopsy forceps.
(Olympus Evis 230 Series catalogue.)

Figure 1.7 Flexible body and handle from an Olympus 16F-2S endoscope. (Reproduced from Bisacre 1980⁵²)



- | | |
|--|--|
| 1 Combined air & lens wash control | 2 Suction button |
| 3 Small channel non-return valve | 4 Large channel non-return valve |
| 5 & 6 Eye piece and viewing lens | 7 Focus ring |
| 8 & 11 Brakes for angulation controls | 9 Up/down tip angulation control |
| 10 Left/right tip angulation control endoscope | 12 Forceps raiser (side viewing endoscope) |



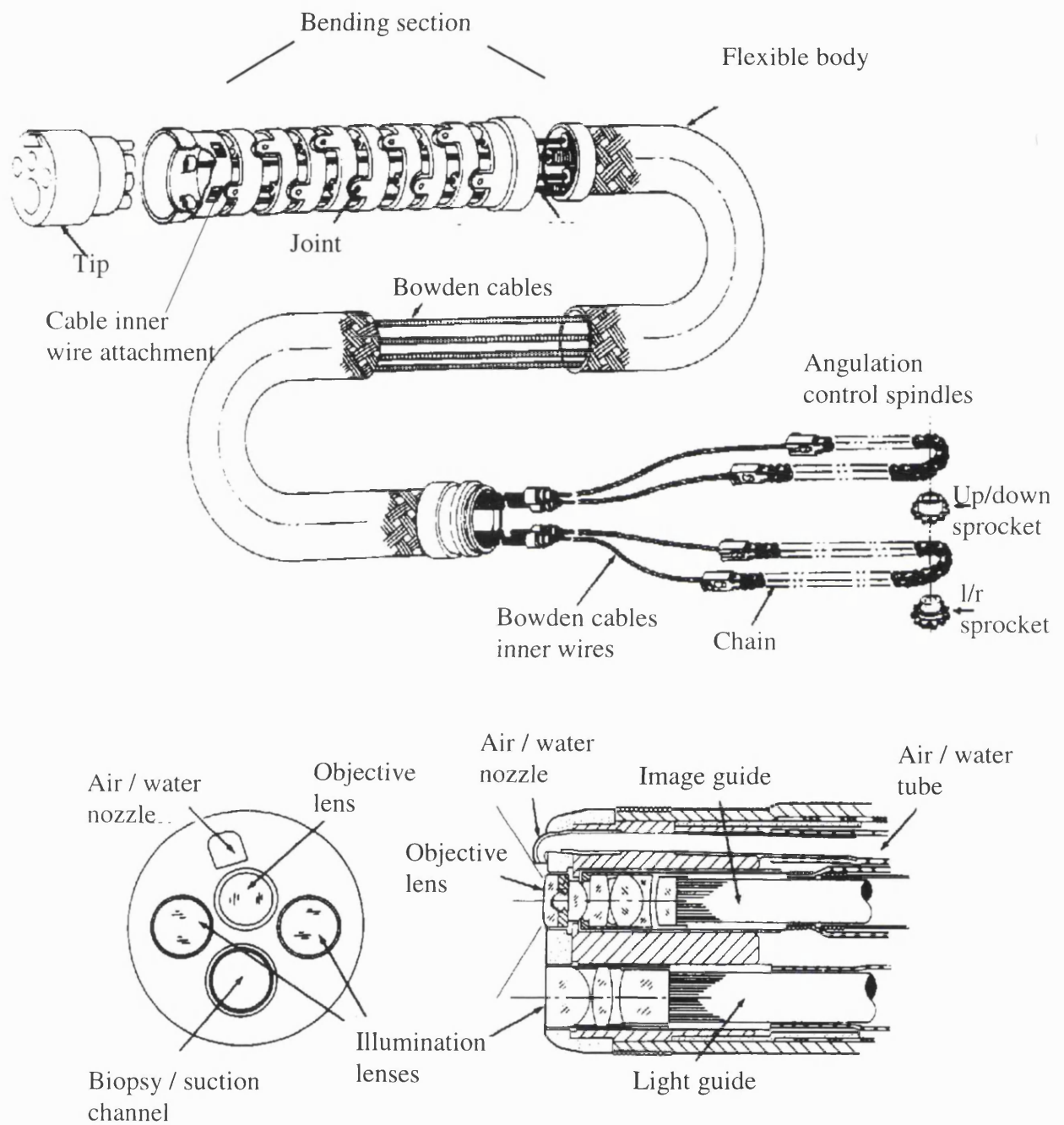


Figure 1.8 Bending and tip sections of a flexible fibre optic endoscope (reproduced from Katzir 199⁵³)

1.5 Conclusion

Since the 1970s advances in colonoscopy have been mainly in the optics with steady incremental improvements being made in the mechanical properties that help with inserting the colonoscope into the patient. This is, perhaps, in part due to the dominance of the industry by camera makers. Never the less, the obvious difficulty of inserting a colonoscope has led a number of workers to propose radical alternatives to conventional push colonoscopy and the next chapter reviews the literature concerned with this.

2 Literature; patents and articles relating to improvements in inserting colonoscopes.

2.1 Introduction

Endoscopes are commercial products and it is therefore not surprising that relatively few articles have been published concerning their design and methods of improving their performance. Searching Medline reveals only a small number of articles about the instrument as compared with the enormous number of articles concerning clinical technique and results.

By contrast a great many patents have been published. Olympus alone, between 1986 and 1996, published 577 American patents containing the word “endoscope” in their title or (since 1991) abstract. In terms of patents Olympus represent almost exactly half the world with 573 US patents being registered by other people or companies in the same period. Rather worryingly the most relevant Olympus patent that we have found does not include the words “endoscope” or “colonoscope” anywhere but instead refers to “pipe inspecting apparatus”.

The vast majority of these patents and articles are concerned with features such as electrical connectors or video technology that are not directly relevant to propelling the colonoscope around the colon. However the obvious problems with looping during push type endoscopy have led a number of workers to describe methods of providing traction at the distal end of the endoscope.

2.2 Overtubes and Spines

As the endoscope proceeds further and becomes more convoluted so less and less of the force applied by the clinician is transmitted to the front portion of the endoscope. It has been suggested that this problem might be eased by using an overtube that can be slid over the endoscope to support it along its shaft so that the forces applied are restrained by the overtube without stretching the bowel into loops.

Overtubes have been commercially available for some time and Bell¹ has presented the use of an overtube during routine colonoscopy. He reports that the speed and ease of colonoscopy was considerably improved when an overtube with an appropriate stiffness was used to brace the sigmoid colon and prevent it from looping. In this study the mean time for progressing from the splenic to the hepatic flexure was 90 (standard deviation 38) seconds for the 23 patients where the overtube was used as opposed to 316 (200) seconds for the control group.

The ideal overtube would be floppy while it was being pushed into place over the endoscope and then become rigid so as to provide the best possible support. Bauerfeind et al² have proposed an overtube with a hollow wall (Figure 2.1) so that when the air is sucked out of the annular gap the inner and outer walls are squeezed together making it (moderately) rigid.

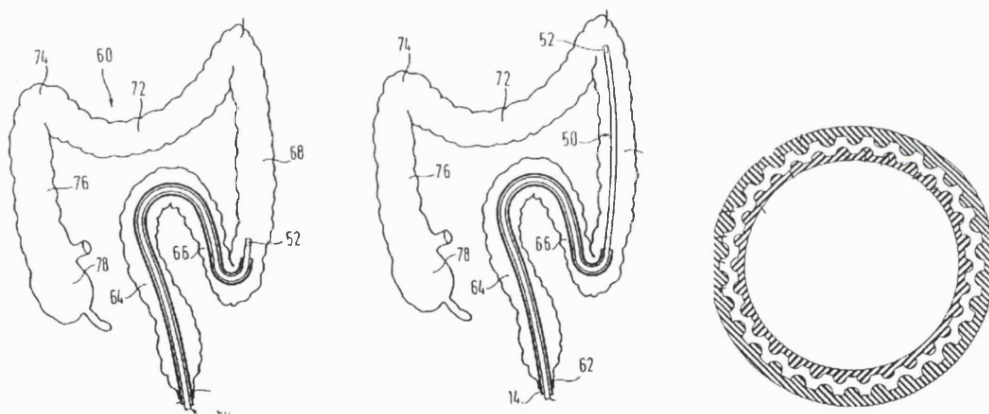


Figure 2.1 Variable stiffness overtube (Bauerfeind 1979)

In his 1979 patent Frazer³ proposed to use a tube containing a metal with a melting point slightly above body temperature so that supplying power to a heater wire wound round it causes it to melt and become flexible, switching off the power makes it rigid again. This is far from “fail safe” as any failure of the power supply would leave the patient with a tortuously shaped rigid rod in his colon.

An internal spine can be used instead of an overtube to help guide the colonoscope around curves. The spine in a floppy state could be slid through endoscope and then made rigid so that the endoscope itself can be slid over the spine which guides it around bends and prevents looping. Sturges et al⁴ have proposed such a “slide motion” scheme

where a flexible spine is slid forward a few centimetres out of the tip of the endoscope, it is then made rigid and the endoscope is advanced over the spine until the tip of the endoscope is adjacent to the tip of the spine. At this point the spine is once again made flexible and the cycle is repeated with the spine being slid forward again.

To make a spine that can be rapidly switched between being flexible and being rigid they propose that the spine consist of a series of close fitting balls and sockets (see Figure 2.2) which can be pulled into each other and locked when a wire that runs along the axis of the spine is tightened. They suggest that the tightness of the wire is controlled by passing an electric current through it so that its temperature and hence its length can be varied. This spine would be too large to fit through the biopsy channel of an existing enteroscope and they envisage an “endoscope conduit” which is more or less a covering tube for the spine with associated optics etc.

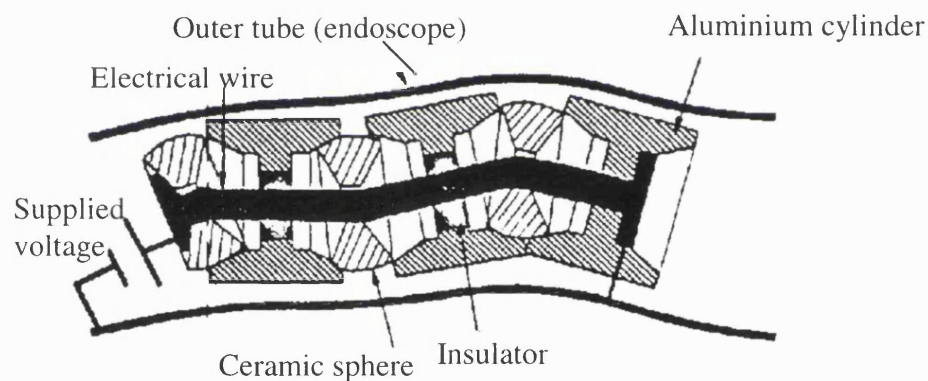


Figure 2.2 Flexible/Stiff spine in a tubular endoscope.
From Sturges 1991 article

In principle overtubes and spines with variable stiffness are attractive but it is doubtful whether they could be practical. Current overtubes are not very flexible and it is hard to imagine a large diameter tube that could be sufficiently flexible to negotiate the splenic flexure and yet be made rigid enough to be useful. Spines suffer from the opposite problem, they have to have a small diameter to fit through a colonoscope while leaving space for the biopsy channel, light guides and so on and it is hard to envisage a “fail safe” mechanism that could make such a long narrow rod rigid.

2.3 Tip propulsion.

The problems inherent to pushing an enteroscope have led to many proposals for methods of providing propulsion at the tip so that endoscopes can pull themselves rapidly through the gastrointestinal tract. Most of these methods simulate the ways that animals move, which is not surprising as there are only a limited number of ways by which locomotion can be achieved. Some of the animals that have been imitated include earth worms, starfish or caterpillars with suction on their feet, snakes, millipedes, quadrupeds and squids or octopi. The animal kingdom has failed to evolve wheels or, despite their name, caterpillar tracks which have also been proposed for propelling endoscopes.

2.3.1 Earthworms

Earthworms move by alternately extending and distending sections of their body to produce peristaltic waves that drive them through the soil. The most common approach to propelling endoscopes has been to imitate the motion of an earthworm by attaching inflatable segments to the endoscope. As embodied in Frazer's 1979 patent⁵ "Apparatus for endoscopic examination" (Figure 2.3) there are two radially expandable bladders separated by an axially expandable bellows, with only the forward bladder attached to the endoscope. The sequence of operation is that (1) the rear bladder is expanded to anchor it against the colon wall, (2) the bellows are then expanded to push the front bladder (and hence the endoscope) forwards, (3) the front bladder is inflated so that it is locked in place against the colon wall, then (4) the rear bladder is deflated and finally (5) the bellows are contracted to draw the rear bladder forwards ready to start the next cycle.

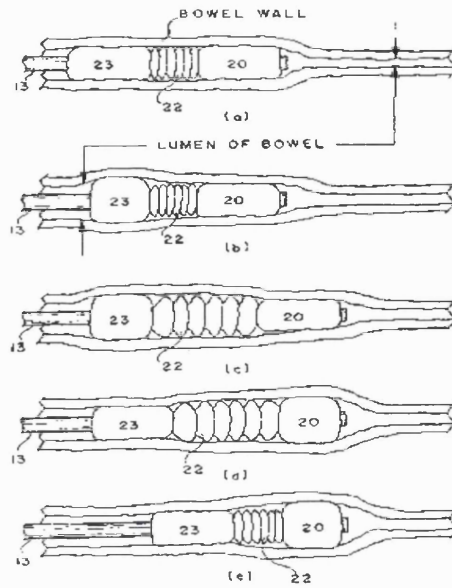


Figure 2.3 The earthworm from Frazer's 1979 patent.

Variations on the worm theme can be found in several other patents^{6, 7, 89, 10} but, so far as we are aware, Liddy's 1987 patent is the only worm method that has been tested with humans. According to the associated article¹¹ they used an overtube (42 in the patent drawing reproduced as Figure 2.4) to open or close the gap between the fore and aft balloons. It was tested in three patients with familial polyposis and apparently advanced well until, in every case, one or other latex balloon burst.

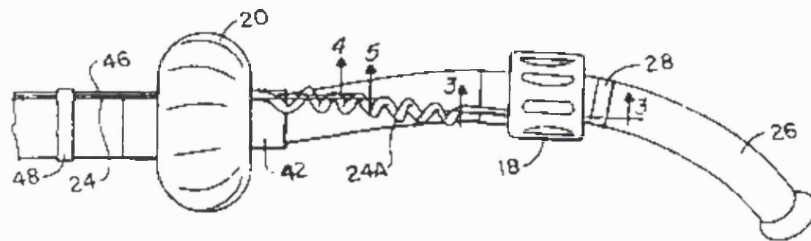


Figure 2.4 The earthworm from Lyddy et al, 1987 patent

The methods described so far simulate an earthworm with only three sections, fore and aft sections that expand radially and a central section that moves axially, however it is possible to make a more realistic worm with many sections. Such a worm is described by Grundfest et al in a patent¹² and an Internet article¹³ (Figure 2.5 is taken from the patent). They use several segments so that waves of distension and extension can move along its body simulating a real worm. The distension is provided by rubber balloons which can be inflated to grip the bowel wall while small pistons provide extension. It has been tested in vivo in the small intestines of an adult pig which "strongly resemble those of a

human juvenile in size and mechanical properties”¹⁴. The authors report their results in an impressionistic way, saying that they were encouraging and that substantial traction was possible but concluding that “Although this machine could indeed move through a portion of the small intestine, it was clear that further development is required to support extensive in vivo experiments”.

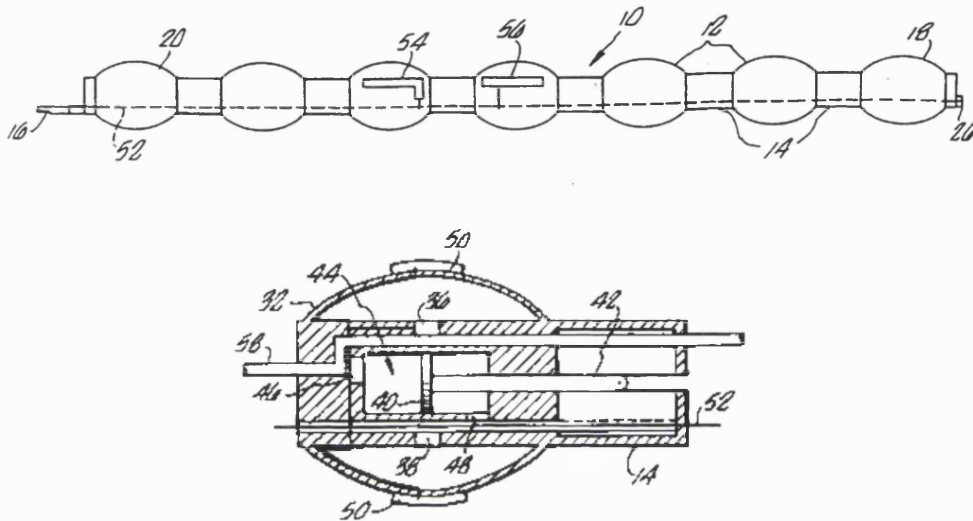


Figure 2.5 The worm and a single section of the worm from Grundfest et al, 1994 patent.

It is understandable that the results in these papers are impressionistic, there is nothing obvious to measure as an indicator of success. Speed of movement is a possible candidate but with a primitive model it is likely to be dominated by practical problems such as filling and emptying balloons.

There has been interest in applying recent “high tech” developments in micromachining and shape memory alloys to making more sophisticated worms. Guber¹⁵ at the Karlsruhe Institut für Mikrostrukturtechnik has proposed using minute valves and balloons to produce a worm to crawl through blood vessels while Carrozza et al^{16 17} have proposed a “teleoperated” worm that has tiny robot arms to manipulate a video camera and take biopsy samples where required. They report that in vivo tests have been made and that “the principle is suitable for propelling the microrobot in the colon efficiently without significant damage to the colon wall”.

The issue of damage to the bowel wall is relevant since any earthworm system gets its grip by inflating a balloon that presses outwards against the walls and it has been known for many years that relatively small pressures can burst the colon and presumably the small bowel. In 1931 Burt¹⁸ inflated the colons from a series of 18 cadavers and found that the pressure required to tear the serosa ranged from 43 KPa (325 mmHg) to only 5.4 KPa (41 mmHg) with a mean value of 18 KPa (137 mmHg). Balloon inflation has caused perforation of the small bowel during Sonde type enteroscopy¹⁹, where a long thin endoscope is introduced into the duodenum, usually via the nose, and then over the course of several hours fed through the small bowel with the aid of peristalsis.

2.3.2 Suction crawlers

The problems associated with inflating cuffs to press against the wall can be avoided by using suckers instead of balloons to grip the wall. Carozza et al²⁰ working in Pisa have used a pair of suction heads separated by a bellows to move through lengths of excised porcine colon. The sequence of operation is the same as for the earthworm described above and the authors report that the “prototype was able to navigate into the colon, both in the forward and backward directions, efficiently, consistently and at sufficient speed.”

A later chapter in the PhD thesis will be devoted to a “suction crawler” system that is being developed to fit onto an existing small diameter endoscopic. In this system the tissue is gripped by the fore and aft suction heads which are moved apart or together by a Bowden cable (a Bowden cable is a “bicycle brake cable,” i.e. an inner wire transmits force by sliding through an outer sleeve that is flexible but of fixed length). No more will be said about suction systems here except to mention that we only became aware of the system developed in Pisa some time after building prototypes.

2.3.3 Snakes

Earthworms move by extension and distension, many snakes rely on serpentine motion where “the body literally swims along in a series of curves which gain a grip from

exerting pressure against sticks, exposed roots, grass blades, pebbles or slight irregularities in the ground”²¹. Robot snakes exist and Sturges²² et al have considered using them for endoscopy. These authors rejected snake robots because they become “computationally and mechanically burdensome as the number of degrees of freedom increases” and because it is difficult to miniaturise them sufficiently to be of use in endoscopy. A recent Chinese article (which this author has seen but not read) titled “Study on Endoscope system driven by squirmy robot.”²³ shows that groups are still working on this approach.

The mechanical aspects of this problem have been tackled by Ikuta et al²⁴ who made an “active endoscope” that is in effect a five segment snake. It uses shape memory alloy tendons arranged about a spine so that each section can bend in three dimensions and they show a series of pictures of it progressing along a rubber model of a section of bowel. In fact they do not operate it as an intelligent snake but rather use a joy stick to manually control the two tip segments and the tip bending instructions are then passed back along the line as the endoscope is then pushed forward so that subsequent sections follow their leader.

The computational aspects of making a snake have been addressed by Shan and Koren²⁵, among others, who made a simple snake that can move across a floor (i.e. in two dimensions) and is clever enough to move towards a planned position despite encountering obstacles.

2.3.4 Millipedes

Millipedes have many legs that move in waves and the same principle can be applied to colonoscopy by making an endoscope with many legs or rings around it that can be made to move back and forth and so march the endoscope forward.

Figure 2.6 is from Utsugi’s patent²⁶ and shows the three inflatable cuffs that form one section of the millipede. The middle (‘propellant’) cuff is the leg which is pushed backwards and forwards by the cuffs either side of it. The sequence of operation is that

the “propellant” cuffs are inflated so that they press against the walls of the colon with enough force not to slip. Next, the “drive” cuffs are inflated thereby pushing the propellant cuffs backwards so that the sheath, and hence the endoscope, moves forwards. The “return” cuffs are now inflated so that they first lift the wall of the gut off the propellant cuffs and then push those cuffs back onto the drive cuffs which are simultaneously deflated. The cycle is now complete and one step has been taken.

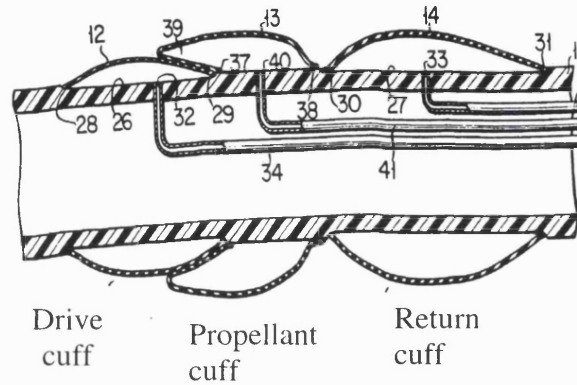
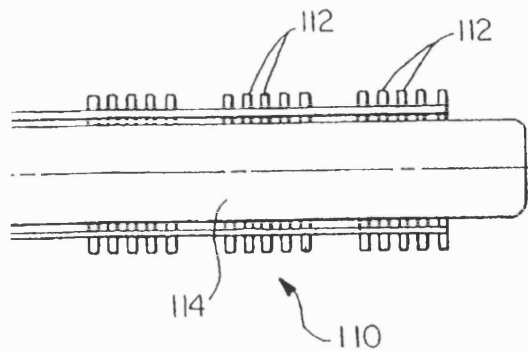


Figure 2.6 Walking system from Utsugi’s 1979 patent

Eleven years later Krauter²⁷ described a somewhat similar but simpler method in his patent graphically titled “Walking borescope” and four years later still Krauter’s colleague at Welch Allyn, Allred III et al²⁸, produced an ingenious design that used washers as feet



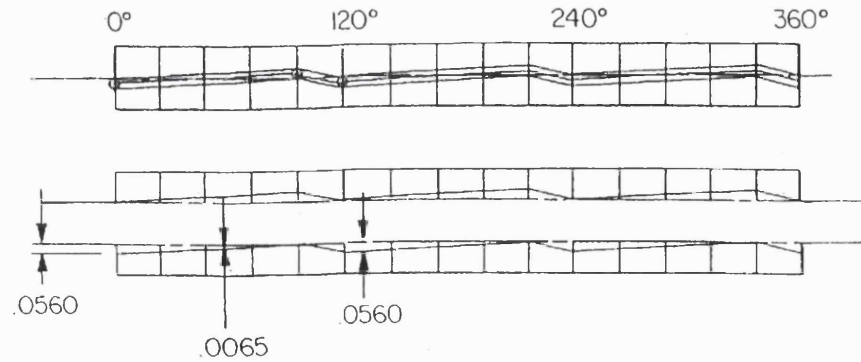


Figure 2.7 Three groups of five washers surrounding the tip of an endoscope and the profile of the cam used to drive one set of washers.
From Allred's 1994 patent

In this design, illustrated in Figure 2.7, the endoscope is surrounded by groups of five washers. All the groups are connected together and move in unison, but within each group every individual washer can be moved independently. Each of the five washers performs a cycle in which it moves slowly backwards and then rapidly forwards. If all five washers did this together then the endoscope would simply rock back and forth; but they don't, they are all out of phase so that at any one time four are moving slowly backwards and only one is moving rapidly forwards. As any driver can attest, the frictional force resisting skidding is independent of the speed of the skid, so in this case the forward propulsion from the four slow washers outweighs the reverse thrust from the one fast washer and the endoscope slowly advances.

During a telephone conversation in 1997 Allred (now working for Allred & Associates Inc. Elbridge NY. USA) acknowledged that the design he had patented could only move in a straight line but said that he had a new design which overcame this problem and could be developed into a practical clinical prototype for the surprisingly small sum of \$100,000. Despite a confidentiality agreement between us he was unwilling to divulge any information because of the open nature of the university lab. It will be interesting to see if anything appears.

2.3.5 Lizards and ants

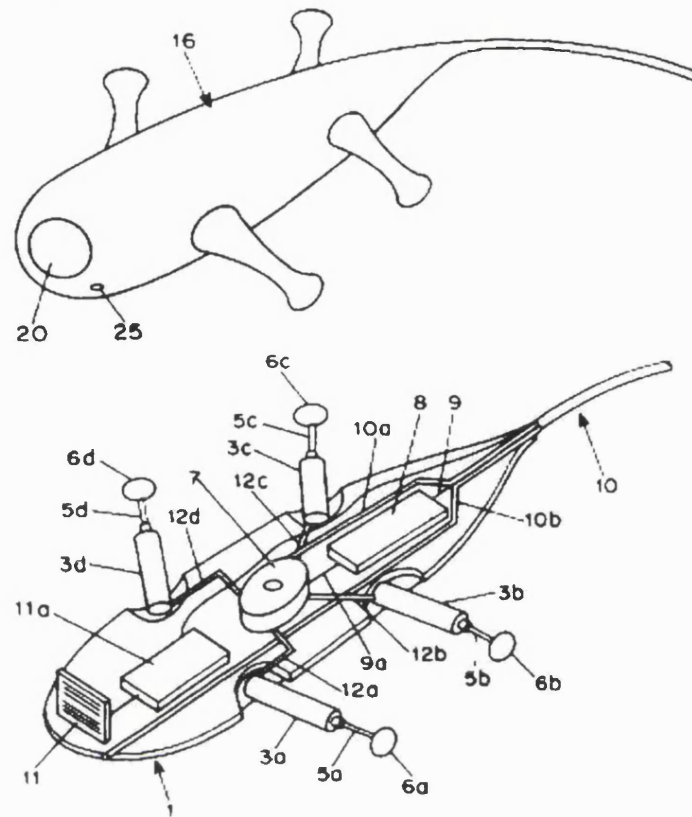


Figure 2.8 The four legged endoscope from Treat's 1997 patent.

Treat and Trimmer²⁹ present a four legged device with legs that can extend as well as pivot at their proximal ends so that the quadruped can literally walk along the gut. It can be seen in Figure 2.8 that the animal analogy is striking and that the creature has a single eye which sends a video image out through its tail to the endoscopist.

In 1993 Goh and colleagues published an article titled 'Future developments in high-technology abdominal surgery; ultrasound, stereo imaging, robotics'³⁰ which shows a robot called Attila that looks like a giant ant and was designed for lunar exploration. The authors speculate that it might be possible to miniaturise this two kilogram robot and allow it to roam the gastrointestinal tract, but they do not review any of the problems that might arise and only conclude that "the technology to do this is still not available."

2.3.6 Octopus.

The octopus escapes from predators by squeezing water from its mantle and jetting away. The physical principle is that a mass is accelerated through an orifice and the force required to do this produces a reaction that pushes the octopus in the opposite direction. It is the same principle that drives a rocket or a jet engine.

This method of propulsion is discussed at length later in chapter 4 of this thesis. As with the 'suction crawler', it was only after building prototypes that we found a reference to earlier work that was relevant. In this case the failure to find the patent during preliminary searches was due to the device being termed a "borescope" rather than an endoscope although in the text the authors do refer to the possibility of using it inside the human body.

Ginsburgh et al³¹ proposed that this principle could be used to propel a borescope and Figure 2.9 shows the tip of the borescope with an attached tube (42 on the drawing) that supplies pressurised liquid to the rear facing nozzle (40).

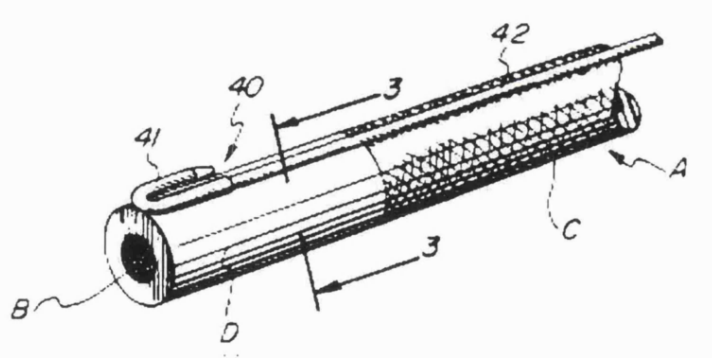


Figure 2.9 A borescope propelled by a jet at its tip from Ginsburgh's 1988 Patent.

2.4 Systems that do not apply traction only at the tip

2.4.1 Wheels, pulleys and vibrators

With the introduction of wheels and pulleys the animal analogies must be dropped. Goh and colleagues in Singapore have worked on vehicles to roam the colon. In 1993³⁰ they published a picture of a device that looks like a toy car but later abandoned wheels and

changed to caterpillar tracks. An early prototypes looked like a model of a First World War tank but by 1999³² the ‘Mark VIII’ tracked vehicle had become a slightly more plausible looking lozenge shape with two tracks on top and two tracks underneath. It appears from a photo to have a diameter of about 30 to 40 mm. The authors report that it was tested in the pig *in vivo* but they do not say anything whatsoever about the results of the test. Interestingly, they report that their most recent designs will “act by the inchworm mechanism”.

Takada³³ has patented a more conventional looking endoscope that has belts running along its shaft that are supposed to act like the tracks of a tank (Figure 2.10). These belts are driven by little pulleys and it is suggested that the grip from the belts onto the bowel wall will be sufficient to pull the colonoscope smoothly and painlessly into the patient.

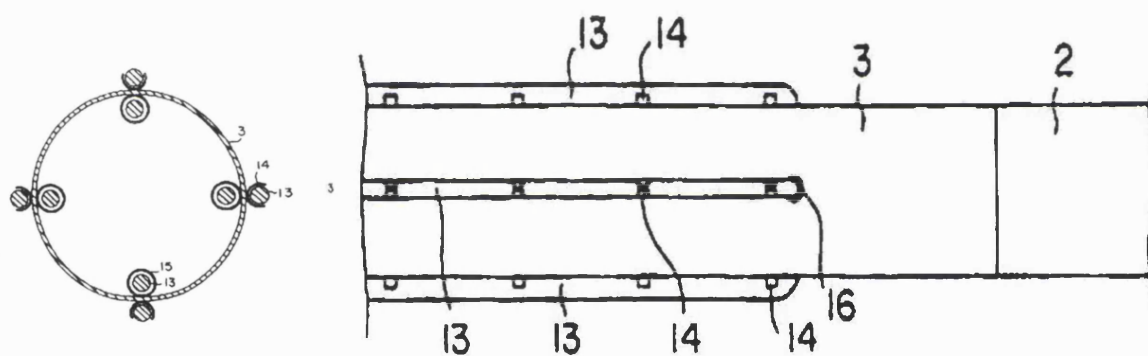


Figure 2.10 Cross section and side views of an endoscope with belts to pull it along the bowel.

13 = belts, 14 = guides to retain belts (Takada’s 1996 patent).

Hibino³⁴ has described an endoscope which contains components to make it vibrate. The authors suggest in their patent that this vibration can reduce the problems associated with forward progression when looping occurs due to friction of the endoscope against the wall. Their device can be made to vibrate “in the vertically (upward/downward) or horizontally (rightward/leftward) directions, in the form of swing motion in which the distal end draws a circle, or in the form of movement (advance/retreat) motion.”

2.4.2 Everting toposcopic endoscopy.

In 1976 Masuda³⁵ filed a patent proposing that a flexible fibrescope (36 in Figure 2.11) could be fed through a conduit by attaching it to the end of an everted tube (i.e. a tube whose end has been turned inwards and pulled back through itself). It can be seen in

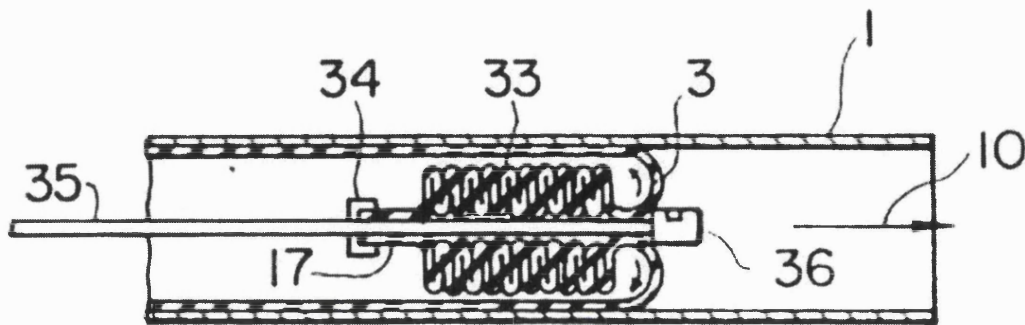


Figure 2.11 An everted tube is used to pull a fibrescope through a conduit. From Masuda's 1978 patent.

Figure 2.1 that when the tube is filled with liquid at pressure it will unroll itself and pull the endoscope forwards and, since the tube is rolling against the conduit wall, there is no sliding friction between it and the wall. It is not clear from this embodiment why the tube unrolling at position 3 should drag remain behind the tip of the endoscope (36) rather than sliding over it and blinding the system; pulling at 3 does not equal dragging at 34. Indeed when this technique has been used to pull catheters through vessels^{36 37} or to carry an endoscope for fallopscopy³⁸ it has advanced "blind" until fully unrolled. What would happen if a blind system advanced into a diverticulum?

Grundl et al³⁹ propose to overcome the problem of the everting tube, or "turnout tube", from covering the tip of the endoscope by providing a pair of rollers outside the patient to nip the endoscope shaft and drive it forward at exactly the same speed as the tube turns out.

We have not found a reference to the use of everting tubes in colonoscopy, although we have been told⁴⁰ that there exists a Russian video (title and author forgotten) showing an everting tube advancing into a horse's colon. It may be possible with humans but, as with so many of the novel schemes for colonoscopy, the practical problems are considerable. On a two dimensional drawing, such as Figure 2.11, the process of unrolling the

membrane looks simple, but it must be remembered that in three dimensions the diameter of the membrane is expanding as it rolls outwards so that in Figure 2.11 it would have to stretch two or three fold. However, if the everting tube is not to balloon out and stretch the colon, then it must not go on stretching once it has everted. which might be possible using for example a braided material. Such a material would have to be crumpled up prior to everting and unless it was extremely flexible there might be problems in unravelling it once the tube had been bent around the sigmoid colon and the splenic flexure.

2.4.3 *Wireless endoscopy*

If a camera, light source, transmitter and power supply could be made small enough to fit into a capsule that could be swallowed, then pain free colonoscopy would be possible. Swain and Gong⁴¹ have constructed prototype wireless endoscopes which incorporate a miniature CCD camera and processor, a microwave transmitter and a halogen light source and which are powered by small batteries. High quality colour television images have been transmitted using these wireless endoscopes in anaesthetised pigs.

Iddan and Sturlesi⁴² have a patent describing a swallowable capsule which includes a minute camera system, light and power supply. The camera is housed inside a capsule whose front portion is a transparent cone and the image transmitted is of the mucosa sliding over this transparent cone as peristalsis pushes the capsule through the intestines. The camera unit includes an “axicon optical element” which, it is claimed, can compensate for the conical shape of the viewing window. The position of the capsule within the patient can be monitored using an antenna array strapped around the patient.

A company named Given Technology Ltd has been established to commercialise Iddan’s capsule and as of July 1999 is promising to have a prototype ready within weeks. They have given up the “axicon element” and are using a conventional CMOS camera behind a transparent dome. It is hoped to add preliminary results to this thesis before submitting it. The capsule is intended for use in the small bowel and it is unlikely to be of much use in the large bowel simply because the bowel is large and the capsule has to be large

enough to be swallowed. As the bowel would have to be uninflated, the capsule would only see the tissues that were wrapped around it and would probably miss small polyps.

In principle it is possible to navigate a capsule through the GI tract using magnetic fields to move it. A group led by Grady, Ritter and Dacey have since 1984 been developing a system using six super-conducting magnets and simultaneous fluoroscopy to perform magnetically controlled neurosurgery. They have now formed a company (Stereotaxis Inc. St. Louis, MO, USA), raised \$18,000,000 to commercialise the system and in 1998 used it for the first time to perform neurosurgery on a human⁴³. Earlier articles^{44, 45} described the magnets driving the probe through the tissues and producing peak forces three times the threshold level required to advance at 1 mm/sec through parenchymal tissues, however the system that has been used with humans used mechanical methods to push into the brain a catheter which had a tip that was steered magnetically.

It is hard to imagine that such a large and complex system would ever be used to guide an endoscope around the colon.

2.4.4 Virtual enteroscopy

Virtual colonoscopy, the use of serial CT or MRI to produce a 3D reconstruction of the colon, is generating a good deal of excitement but has not yet achieved the necessary diagnostic specificity to alter current medical practice. Since this thesis is concerned with improving the method of *inserting* colonoscopes, virtual colonoscopy will be ignored except to say that if it leads to an increase in screening then it will reveal many suspect polyps that require biopsy or minimally invasive surgery and so will generate more work for conventional endoscopists. Readable accounts of the current status of this technology have been written by Blezek⁴⁶, Vining⁴⁷ and Alquist⁴⁸ and an up to date comparison of CT, MRI and conventional colonoscopy and colonography can be found in Bauerfiend et al⁴⁹.

2.5 Conclusion

It is impossible to know which, if any, of the non-virtual systems will be successful. It is doubtful if any of the methods involving complex mechanisms could be small enough for colonoscopy and at the same time rugged, reliable and hygienic. Whether or not complex robotic devices can be made to work, it is certain that the resources and skills required were not available for this PhD project.

The earth worm systems are simple and popular but have the inherent problem that they get their grip by pressing outwards onto a tube that may burst. Capsules containing cameras will become possible but, unless the camera capsule can grow in the gut, any capsule that can be swallowed will be too small to inspect the entire surface of the uninflated colon.

This leaves water jets, suction crawlers and everting tubes. Water jets and suction crawlers are discussed in later chapters and given time it would have been interesting to investigate the use of everting tubes as they might be a promising approach. Despite their promise there are major practical problems of making a tube that can evert for 800 mm or more, has a diameter of only about 20 mm and can make its way around tight bends. There are also safety concerns if the tube advances blindly.

Reading the literature it is apparent that many of the approaches are more ingenious than practical and that relatively few have been tested or, at least, have had the results of tests published. In view of the work that is presented later in this thesis, it would be a mistake to throw stones at these glass houses.

This chapter ends with Figure 2.12, a reproduction of Figure 1 from Nagel's 1978 patent,⁵⁰ which needs no comment.

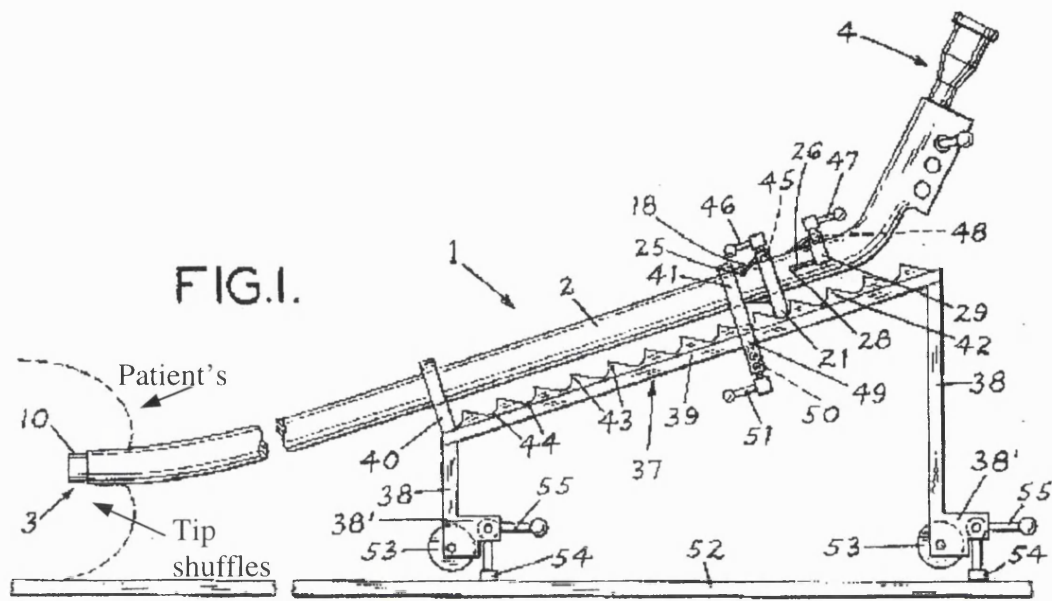


Figure 2.12 An endoscope is ratcheted into the colon while its tip shuffles back and forth. From Nagel's 1978 patent.

3 Measurement of the forces exerted by the clinician on the endoscope during colonoscopy.

3.1 Introduction.

It was decided that before attempting to improve the method of inserting a colonoscope it would be best to make a study of the existing technique. Many previous workers have described colonoscopy and some have attempted to measure the success of a particular technique by recording the time taken to reach, for example, the caecum¹ or employing psychological techniques to assess pain.² However, so far as we were aware no one had previously measured the forces used by the endoscopist. It seemed likely that any improvement to colonoscopy would involve reducing the force required to push the endoscope.

Dr Bell, then at The Ipswich Hospital, suggested that it would be interesting to measure the torque applied to the endoscope as an important skill for an endoscopist is to know when, in what direction and by how much to twist the instrument. The rest of this chapter describes the device that was designed and built to measure the forces, both axial and rotational, exerted by the clinician on the endoscope during colonoscopy. The device was also used to measure the forces applied to thermoelastic 'bougie' dilators of 13 and 18 mm diameter during oesophageal dilatation and results from this study were presented as a poster display³ which is reproduced in black and white as Appendix 2.

From the point of view of the author, a major benefit of this work was that it forced him to spend days closely observing endoscopists at work. However, in as much as both the endoscopists involved were eminent and exceptionally skilful, what he saw understated the problems. Similarly, the measurements probably underestimated the forces used by less experienced practitioners.

This chapter is an expanded version of an article that was published in *Medical and Biological Engineering and Computing*⁴.

3.2 Method

3.2.1 Mechanical design

The principle of the device is that the endoscopist does not hold the shaft of the endoscope directly but instead uses a tubular hand grip that is closed around the shaft of the endoscope. The hand grip contains strain gauges that measure the forces transmitted from its outside, which is held by the endoscopist, to its inside, which holds the shaft of the endoscope.

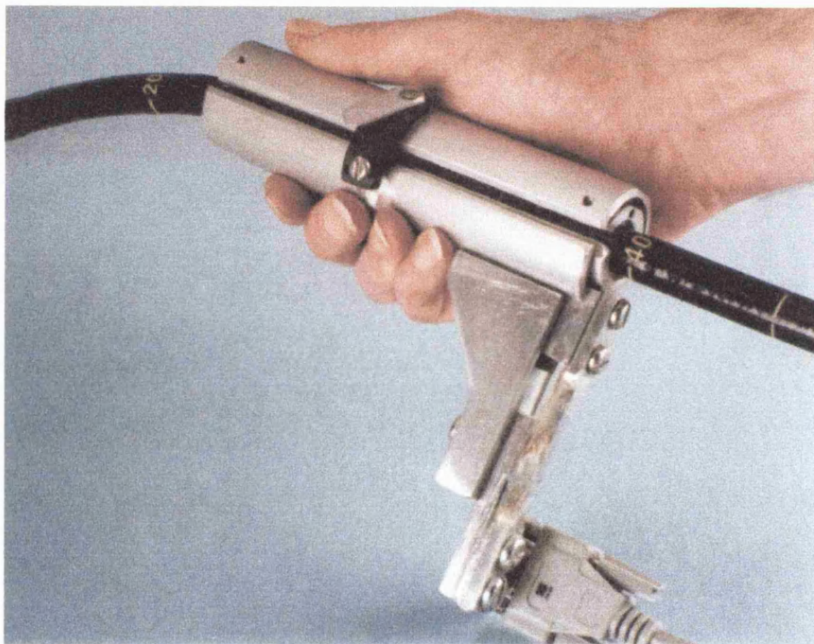


Figure 3.1a The handgrip being closed around an endoscope.

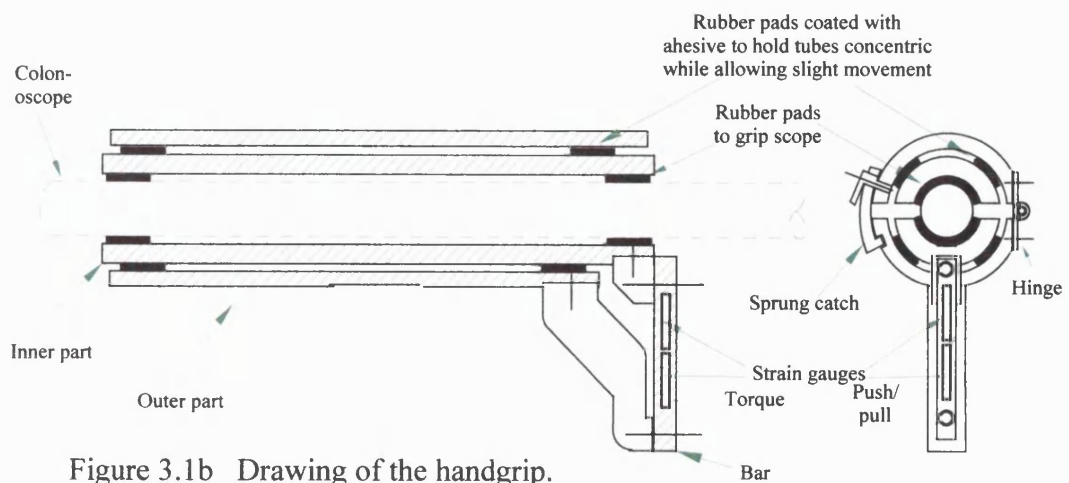


Figure 3.1b Drawing of the handgrip.

Figures 3.1a and 3.1b show a photograph of the hand grip being closed around an endoscope and a drawing of the hand grip. It can be seen that the hand grip is in the form of a hinged split cylinder that can be locked around the endoscope like a pair of clam shells. The cylinder has two parts, an inner pair of shells that grip the scope and an outer pair that is gripped by the clinician. The inside part was made by splitting a 150 mm length of aluminium tube of i.d. 18 mm and o.d. 30 mm, whilst the outer part used tube of i.d. 32 mm and o.d. 40 mm.

The inner shells are attached to the outer shells by eight rubber pads (6 x 6 mm x 2 mm thick and about 40 Shore hardness) that are glued to the aluminium using double sided adhesive tape. These pads allow a little movement between the inner and outer shells. However, in one place, the shells are also joined by a comparatively stiff aluminium bar (6 x 6 mm with the flexible section being 50 mm long). As the endoscopist moves the outer shells, the bar flexes as it transmits forces through to the inner shells. The bar has strain gauges attached to it to form a load cell that is used to measure the forces applied to the endoscope.

Rubber pads are also glued to the inside of the inner shells so that when the grip is closed, the shaft of the colonoscope is held firmly but not damaged. These pads can be easily peeled off and changed for thicker or thinner pads to cope with different diameter endoscopes. Flexing of these pads does not affect the measurements as the forces being transmitted to the endoscope from the clinician's hand must still pass via the joints between the inner and outer shells.

During colonoscopy, the hand grip can be readily unlocked and moved along the shaft of the endoscope or removed altogether. This is achieved using the hinge and sprung catch mechanism that can be seen in Figures 3.1a and b. The catch is mounted onto the upper shell with an eccentric bush that can be rotated using the small aluminium lever that can be seen just below the base of the endoscopist's thumb on the right hand side of Figure 1. This bush is eccentric by about 3 mm and is used to tighten the grip around the endoscope once it has been closed with the catch. The advantage of this toggle action is that the bore of the hand grip does not have to exactly match the diameter of the endoscope and that the operator does not need to use great force to squeeze the grip tightly closed.

The disadvantage of this method of gripping the colonoscope shaft is that the endoscopist cannot slide his hand up and down the shaft. Instead he has to keep his grip in one place and then pause while the handgrip is moved and the system re-zeroed.

3.2.2 *Electronics and computing*

Figure 3.2 is a block diagram of the analogue circuit and it can be seen that the bar connecting the inner and outer parts of the hand grip is equipped with four strain gauges (polyester backed 8 x 2 mm foil gauges supplied by RS components). Two are mounted onto the rear face of the bar and are sensitive to pushing and pulling of the endoscope and two are mounted to a side face of the bar to monitor the sideways deflection as it resists the torque being applied to the endoscope.

The strain gauges are connected by a cable to a battery powered and optically isolated signal conditioning unit (patient isolation to Class 1 Type BF). For each channel, the strain gauges form half a Wheatstone bridge whose output is fed into a high gain (x 3,000) precision amplifier.

Potentiometers are used initially to balance the bridges. However, each time the hand grip is closed and tightened around the endoscope, the bar carrying the gauges buckles slightly and the output has to be reset to zero. This is achieved quickly and conveniently by pressing a button on the front panel that triggers a “sample and hold” circuit to store the present value of the output which is subtracted from future values as an offset. The issues concerned with re-zeroing the system will be considered further in the section discussing the results obtained.

To avoid logging large amounts of irrelevant data we added a push button switch on a “wander” lead as can be seen on the circuit diagram. The software was written so that data was only recorded while this button was being pressed.

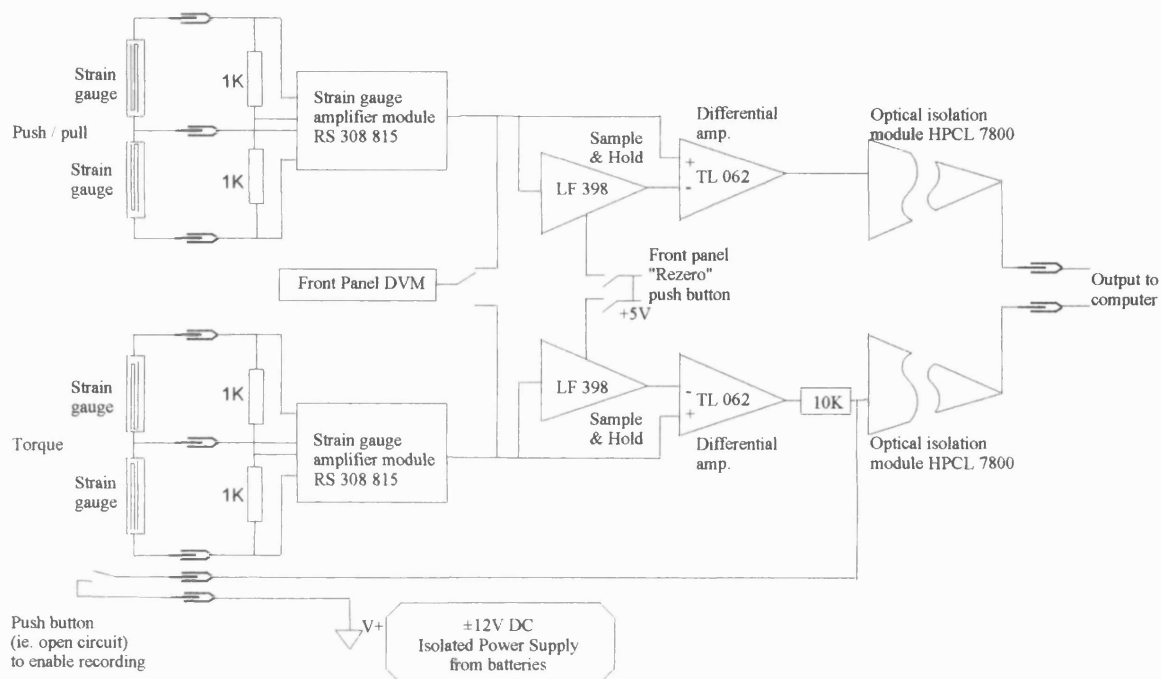


Figure 3.2 Block diagram of the analogue circuit

The analogue output from the signal conditioning unit is digitised using a Keithley Instruments DAS 1200 ADC card housed in a PC computer. The program that processes the data was written using a “virtual laboratory” software package (Labtech for Windows, Notebook Pro, version 8.01). The calibrated output is displayed on the monitor in real time as a chart recorder style trace with torque measured in Newton metres and push in kilograms force (Kilograms being preferred to Newtons because the unit is more familiar to clinicians). The program also generates a data file of the two channels and the time elapsed since the start of the run .

The experimenter used a ‘dictaphone’ during the procedures to report on what was happening and when. These verbal reports were used to annotate the graphs presented below.

3.2.3 Positioning system.

The position of the endoscope within the colon was continuously monitored during three colonoscopies using electromagnetic imaging apparatus supplied by John Bladen (JBS Ltd, Sheffield)⁵⁶ “Non-radiological technique for three dimensional imaging of endoscopes”.

This system uses a long catheter that is inserted into the biopsy channel of the colonoscope. Evenly spaced along the lumen of the catheter are 16 small electromagnets that can be pulsed sequentially. The position of each magnet as it pulses is detected by three sensors that are built into the bed under the patient. The output from the sensors is used to compute in real time a three dimensional picture of the position and shape of the endoscope. This is related on the screen to anatomical landmarks, such as the anus or splenic flexure, that are approximately marked by the endoscopist at the start of the procedure.

3.3 Calibration.

‘Pull’ was calibrated by closing the grip around an endoscope and then zeroing the system before tying known weights to the endoscope. ‘Push’ was calibrated by simply turning the hand grip around so that it was pointing towards the endoscope’s hand wheels and then repeating the procedure. To calibrate torque, the endoscope was replaced by a ‘T’ bar and weights were hung from the cross bar. Figure 3.3 displays the results of the calibration tests and Table 3.1 shows the cross talk between the channels.

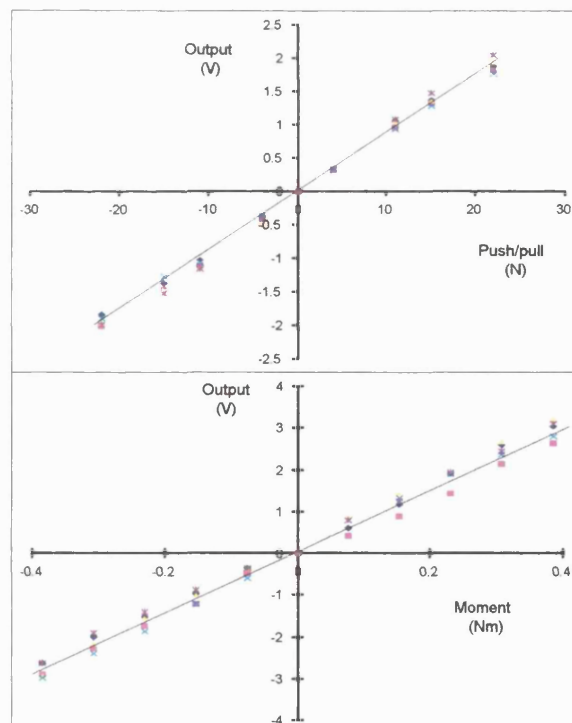


Figure 3.3 Calibration results (the electronic gains had already been adjusted so that 1V was about 10 N or 0.1 Nm)

Torque applied (Nm)	“Push” measured as a result (N)	Push applied (N)	“Torque” measured as a result (Nm)
0	0	0	0
0.16	0.5	4	-0.06
0.32	0.6	11	0.1
0.48	0.6	15	0.04
-0.16	-0.2		
-0.32	-0.4		
-0.48	-0.7		

Table 3.1 Cross-talk between channels.

The software allows for non-linear scaling and for a fraction of the signal from one channel to be subtracted from the other channel to allow for the possible presence of cross-talk. In practice, the calibration results presented in Figures 3.3 and Table 3.1 show that a linear scaling factor was sufficient and that no significant cross-talk existed.

3.4 Force measurements during colonoscopy in patients

Measurements have been made for a total of about 85 minutes during eleven colonoscopies in ten patients performed by two endoscopists. Results are summarised in Table 3.2. During this time the colonoscope was being pushed with a significant force (i.e. greater than 1 N) for 34 minutes. The strength of this force exceeded 10 N for 7.2 minutes (21% of the time the endoscope was being pushed) and 20 N for 55 seconds (2.7% of the time).

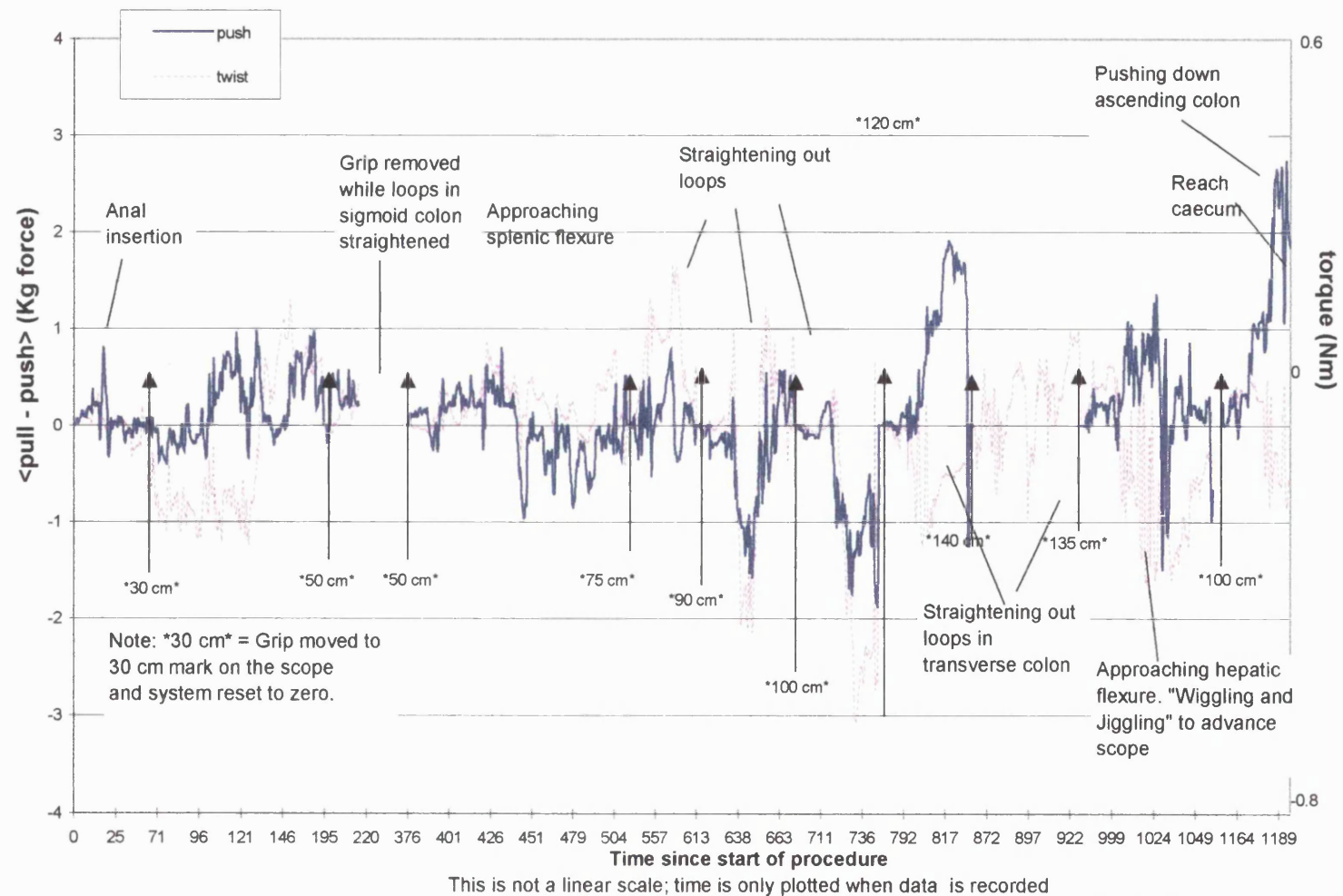
The highest forces only occurred for very short periods of time. The peak force only exceeded 34 N on two occasions (different patients) and for a total time of less than six seconds.

Patient (age)	Reason for endoscopy	Duration of record (s)	Peak push (N)	Peak pull (N)	Peak clockwise torque (Nm)	Peak anti-clockwise torque (Nm)	Push at anal insert. (N)
1 (69 yrs)	Ulcerative colitis	240	44	12	0.6	0.4	8
2 (41 yrs)	Polyp follow up	150 & 300	7 & 17	4 & 12	0.3 & 0.6	0.2 & 0.5	7 & NA
3 (71 yrs)	Left side abdo. pain	120	17	2	0.1	0.2	5
4 (32 yrs)	Rectal bleed - haemorrhoid	200	13	2	0.2	0.1	9
5 (45 yrs)	Diarrhoea	600	22	15	0.6	0.8	22
6 (35 yrs)	Altered bowel habit	720	34	15	0.5	0.5	5
7 (78 yrs)	Polyp	400	21	5	0.3	0.2	11
8 (49 yrs)	Irritable bowel	700	25	15	0.2	0.3	8
9 (40 yrs)	Rectal bleed	720	22	18	0.4	0.2	18
10 (70 yrs)	Laxative user-negritis.	950	29	17	0.5	0.5	10

Table3.2 Summary of first eleven colonoscopies during which recordings were made. In the last three procedures the location of the endoscope was tracked electronically.

Figures 3.4 and 3.5 present data from two of the three patients where the position of the endoscope was monitored and the information from this has been used to annotate the chart. It shows the time during which the colonoscope was being inserted. The solid line represents the forces used to push or pull the scope and its scale is on the left hand side. The dotted line represents torque, its scale being on the right. The vertical arrows mark times when the grip was removed from the colonoscope, and the number at the base of the lines (e.g. *30 cm*) shows the distance from the front of the hand grip to the tip of the endoscope when the grip was replaced. After replacing the grip, the system was always reset to zero. Also it is important to note that the time during which the grip was removed is not displayed and this accounts for the jumps in the numbers along the time axis.

Fig. 3.4 Forces exerted while inserting a colonoscope into a 40 year old man with irritable bowel and a family history of colorectal cancer.



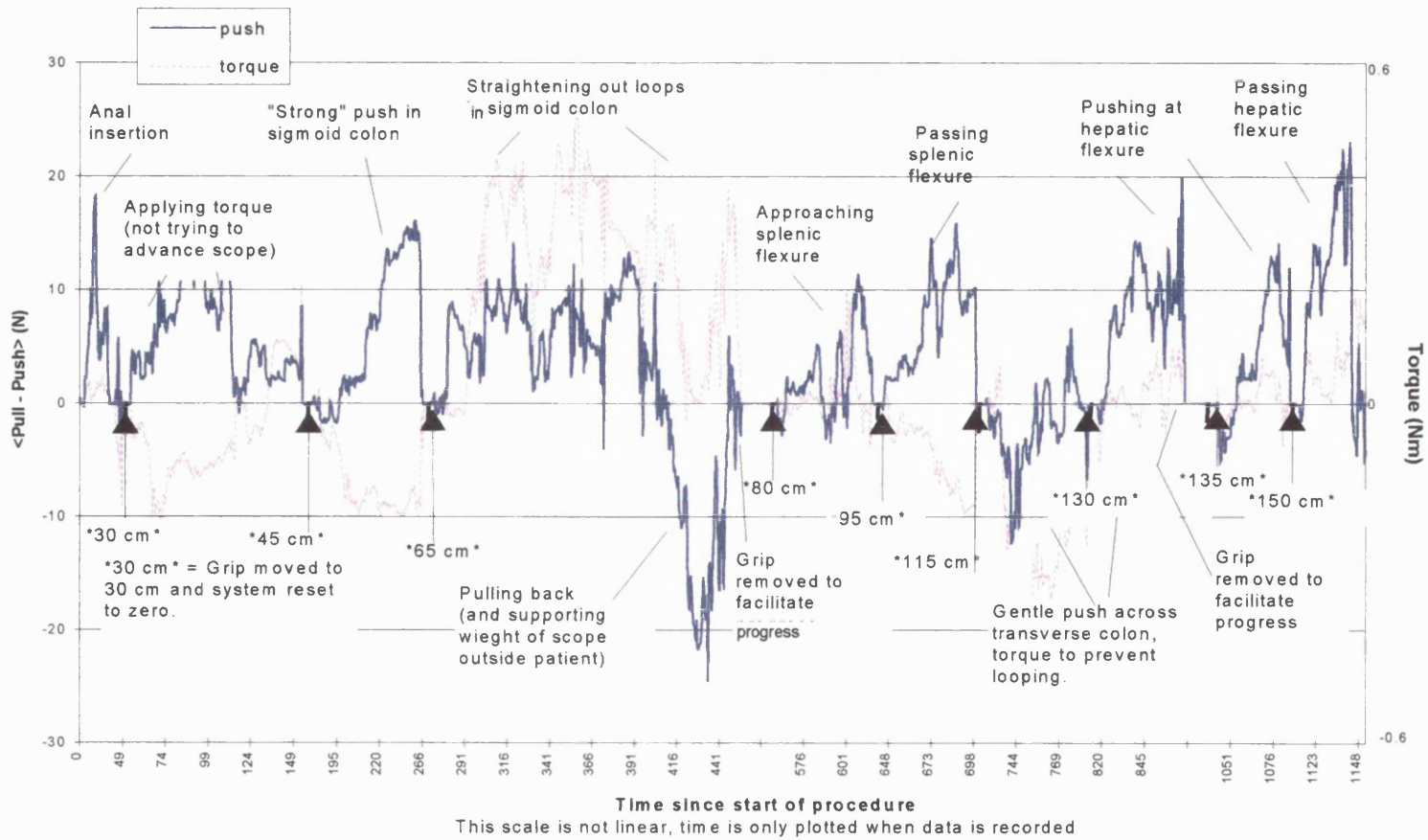


Figure 3.5 Forces exerted while inserting a colonoscope into a forty year old male with rectal bleeding.

In general the strongest pushing forces occurred when manoeuvring to pass the splenic and hepatic flexures and when pushing past loops in the sigmoid colon. There was a tendency for the hardest push to be when the colonoscope was stuck and so be associated with minimal progress. Conversely good progress was associated with moderate pushing of about 5 to 12 N. However there were occasions when higher forces of up to 20N were associated with advancing the scope.

In the discussion section it will be seen that it is unclear what proportion of the torque measured related to forces within the patient's colon rather than to twisting the umbilicus and other parts of the endoscope outside the patient. For this reason it is best to regard the torque trace as no more than an indication of whether clockwise or anticlockwise torque was being applied.

Clockwise torque was used to straighten out loops in the sigmoid colon but both clockwise and anticlockwise torque was applied to remove loops in the transverse colon. Curiously, one of the endoscopists tended to apply mild clockwise torque to the endoscope most of the time. This may be due to the way in which the shaft behind the grip was lying on the bed.

3.5 Discussion

Though not unduly inconvenient to use as a research tool, the device is not intended for routine clinical use. The two clinicians who used it during colonoscopy commented that it made the procedure only slightly more difficult. The change in the feel of the endoscope was initially distracting but it was agreed that with repeated use this became less apparent. The need to unlock the hand grip, move it along the shaft of the endoscope, re-lock it and then rezero the system every few minutes was also slightly inconvenient.

It should be emphasised that the device measures the push/pull and twisting forces (torque) applied to the shaft of the endoscope rather than the forces or pressures applied directly to the colon wall. Such direct measurements are difficult to accomplish in practice. The forces applied by the endoscopist to the shaft of the endoscope do not discriminate between forces which enter the patient and forces which are required to carry the weight of the endoscope

etc. This is particularly significant when measuring the torque since much of the force is used to twist the parts of the endoscope that are outside the patient such as the hand controls and the umbilicus. It is likely that the torque required to support or turn the parts of the colonoscope outside the patient may sometimes be greater than that required to twist the endoscope inside the colon. Indeed, in bench tests we have recorded large torque when the tip of the endoscope was in free air with no resistance to being twisted. We considered removing the measurement of torque altogether but decided to keep it as it might be helpful in making colonoscopy simulations and shows when, and in which direction, torque is being applied.

The measured values of force and torque had to be reset to zero whenever the hand grip was moved along the shaft of the endoscope. We tried to ensure that the colonoscope was untwisted before doing this to minimise the offsets that were introduced. So far as push/pull is concerned, we asked the endoscopist to hold the scope in place in the colon without trying to advance or retract it and then, while he was “in neutral”, we electronically re-zeroed the measurements. It should be noted that this does not mean that the endoscopist was applying no force to the endoscope but rather that he felt he was doing no more than carrying the weight of the scope.

The decision to set the measurement to zero when the clinician *felt* that it should be zero, rather than when the forces being applied to the shaft of the colonoscope actually were zero, meant accepting a source of error that cannot easily be quantified. The decision to introduce an approximate tare was taken reluctantly as it compromised the objectivity of the measurements. However in this case it seemed more helpful to make a rough measurement of what is of interest than an accurate measurement of what is irrelevant.

Supporting the weight of the colonoscope is not the only way in which force applied to the shaft of the colonoscope may not be transmitted internally to the bowel wall. For example, if the push is not directed straight at the anus then it will be resisted by the buttock. This particularly tends to happen while the clinician is using torque and the deliberate rotation about the axis is often accompanied by a rotation of the axis. This accounts for the correlation that can be seen between “push” and the magnitude, but not the direction, of the torque.

3.6 Conclusion

Excessive force during colonoscopy causes pain and is dangerous and therefore any device that is intended to improve the ease of inserting a colonoscope should not only reduce the skill and time required but also reduce the forces applied by the clinician on the endoscope. To the best of our knowledge this is the first time that these forces have been measured.

Introduction to Chapters 4, 5, 6 and 7.

The following four chapters describe the devices that were built and tested in the hope that they would assist in the insertion of colonoscopes.

It may be remembered that on the first page of the introduction it was stated that “The reason for [the difficulty of inserting a colonoscope] is that the colon is an elastic tube that follows a tortuous path. As the colonoscope is pushed around a bend it does not always slide smoothly along the colon wall but frequently catches on it so that as the colonoscope is pushed further in, the colon is stretched and a loop is formed.” The first three devices that will be described attempt to overcome this problem by providing traction at or near the tip of the endoscope to pull the endoscope and so obviate, or at least lessen, the need for pushing. The fourth device minimises the friction between the shaft of the colonoscope and the wall of the colon so as to reduce the tendency to catch on the wall and produce a loop.

Early in the project a document was produced that outlined a number of alternative approaches to improving the method of inserting a colonoscope. This document has served as a menu from which to select the next course of work and it is reproduced as Appendix 3. The criteria for choosing which approaches to pursue were, apart from the obvious criterion that they might work, that the systems potentially should be;

Safe

Buildable with the limited resources available

Not duplicating work that other groups are engaged in and are better qualified to carry out,- e.g. robots.

Capable of being made as a disposable or made to a hygienic design that can be disinfected’ - i.e. no hidden surfaces, blind holes, crevices etc.

Compatible, if possible, with existing endoscopes so that the very considerable technology they incorporate does not have to be reinvented

One advantage of a PhD project is that the approach does not have to be cautious. It was decided that ‘way out’ ideas could be investigated so long as they looked interesting.

Two of the four approaches that have been investigated have already been met in the literature survey. They are the use of water jets to provide propulsion at the tip of the endoscope (Section 2.3.6) and the use of suction cups to allow a crawler to pull the endoscope forward (Section 2.3.2). The third method is probably the most novel, a lozenge shaped device has electrodes mounted on its tapering tail that stimulate the smooth muscle of the bowel to contract thereby squeezing the lozenge forward so that new tissues are brought into contact with the electrodes which in turn contract and keep the device moving forward. The fourth and final method to be investigated is to use a disposable sleeve coated with a “lubricious” hydrogel to minimise the friction as the endoscope is pushed along the bowel.

This last approach is potentially very inexpensive and practical and it is known that other groups have discussed it but we have been unable to find out whether any of them have actually tested it. It will be interesting to hear whether the examiners know anyone who has already tried using a hydrogel coated sleeve.

4 The water jet propelled endoscope

4.1 Introduction

The principle of jet propulsion is that as a mass of liquid is forced to accelerate through a nozzle so it applies an equal and opposite force to the body that holds the nozzle. This principle is employed by a squid or octopus when it accelerates rapidly away from danger by squeezing water out of its mantle¹. In our application pressurised water (or isotonic liquid) is pumped to a head attached to the distal tip of an endoscope where it is turned back 180° on itself and accelerated out through a number of small nozzles. Figure 4.1 shows a tube being dragged vertically upwards by a head with three water jets.

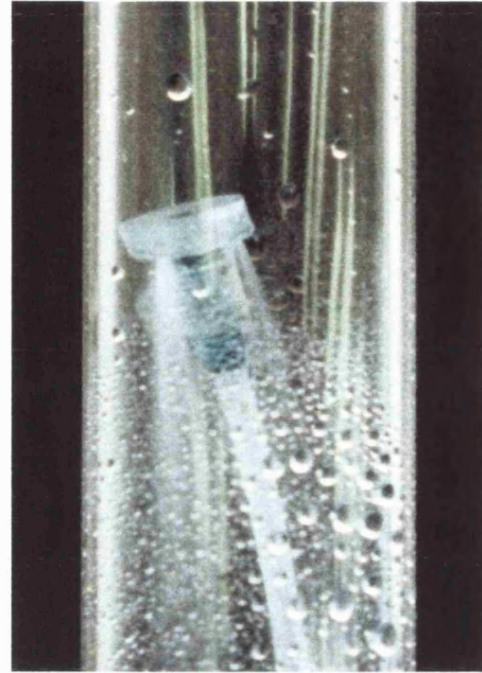


Figure 4.1 Water is pumped up a 3.2 mm OD tube to a head with three downward facing holes. The force from the jets enables it to perform the “Indian rope trick” inside an acrylic tube

So far as we are aware this principle has not previously been applied to colonoscopy although the possibility of doing so is mentioned in the patent entitled “Method and apparatus for fluid propelled borescope”² that was described in the literature survey, Section 2.3.6.

Jet propulsion is attractive for endoscopy because very little mechanism is required inside the colon, indeed the only moving part is the water that flows through the nozzle. The complex components such as the pump and the control system can all be placed well away from the patient where size is not a problem. Another attraction is that the thrust generated can theoretically be increased indefinitely by increasing the mass of liquid flowing or increasing the change in velocity imposed on the liquid. The principal disadvantages are that in practice the thrust that can be produced is not very large because the flow rate is limited by the need not to overload the colon with water and the velocity is limited by the danger of piercing the colon wall with a jet of water.

4.2 The thrust from a jet.

The thrust generated as water accelerates through a nozzle can be found by applying the conservation of momentum to the system³.

Let;~

- Volume flow rate = Q
- Mass flow rate = Q_{mass}
- Density of liquid = ρ
- Water velocity at outlet = V_{out}
- Water velocity at inlet = V_{in}
- Area of outlet = A
- Area of inlet = A_{in}
- Thrust from jet = F

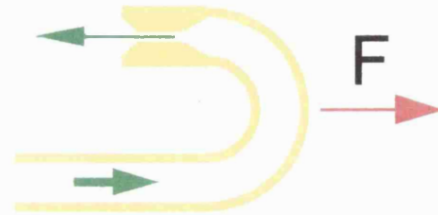


Figure 4.2 Water is turned around and accelerated out through a nozzle.

Force applied to the water = Rate at which momentum changes.

$$\begin{aligned}
 F &= Q_{\text{mass}}(V_{\text{out}} - V_{\text{in}}) \\
 &= Q_{\text{mass}}(Q/A - Q/A_{\text{in}}) \\
 &= \rho Q^2 (1/A - 1/A_{\text{in}})
 \end{aligned}$$

When the inlet area is large compared with the outlet area this simplifies to

$$F = \rho Q^2 / A$$

We have so far spoken of the “outlet area” (A) without being specific as to what this refers to. When a liquid flows through an orifice the current ‘necks down’ as it accelerates so that the product of velocity and cross sectional area remains constant. As is illustrated in Figure 4.3 this means that

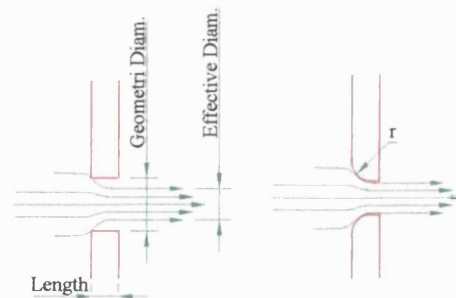


Figure 4.3 The ‘Vena Contracta’.

where the inlet has a sharp edge the effective area of the orifice is less than its geometric area. It has been found empirically⁴ that over a wide range of Reynold’s numbers the effective area ranges from 62% of the geometric area for a square edged orifice to 100% for an orifice with a gently curving inlet ($r > 0.5$ geometric diam.). Surprisingly, making the length of the orifice greater increases the coefficient until it reaches 82% when the length is two to three times the diameter.

It is possible to bring the pressure drop across the nozzle into the picture by considering the conservation of energy. In this situation, illustrated in Figure 4.4, the energy lost to friction as a result of the water's viscosity is negligible and Bernoulli's law may be applied. The energy lost or gained by the water as a result of a change in height may also be safely ignored so that the rate of loss of pressure potential energy can be equated directly to the rate of gain in kinetic energy.

Let;~

- Inlet velocity of the water = zero
- Outlet velocity of the water = V
- Inlet gauge pressure of the water = P
- Outlet gauge pressure of the water = zero
(ie. $\Delta P = P - 0 = P$)
- Volume flow rate = Q
- Mass flow rate = Q_{mass}
- Density of liquid = ρ
- Effective cross sectional area = A

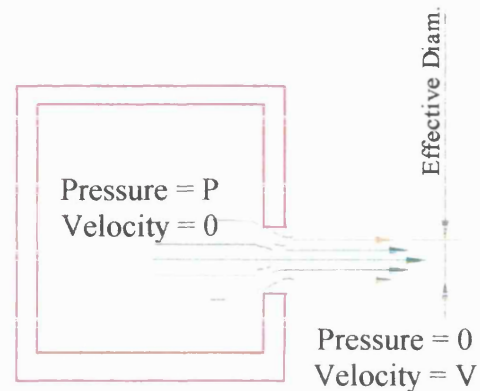


Figure 4.4 Water being driven through an orifice

Rate of loss of energy due to pressure drop = $\Delta P Q = P Q$

Rate of gain of kinetic energy = $\frac{1}{2} Q_{\text{mass}} V^2 = \frac{1}{2} \rho Q V^2$

Applying the conservation of energy gives;

$$P Q = \frac{1}{2} \rho Q^3 / A^2$$

$$P = \frac{1}{2} \rho Q^2 / A^2 \quad (\text{which is a common form of Bernoulli's law})$$

Substituting $F = \rho Q^2 / A$ from above,

$$P = \frac{1}{2} F / A$$

$$F = 2 P A$$

4.2.1 Experiment to confirm ' $F = 2PA$ '

The presence of the factor of two in $F = 2PA$ seemed most surprising and an experiment was performed to validate the result using the apparatus illustrated in Figure 4.5. This or similar apparatus was used to measure the thrust from many designs of nozzle and prototype jet propelled endoscopes.

The apparatus consists of a plank, supported by pillars either side of a sink, that carries a standard electronic balance (Mettler PM2000) which in turn carries a rectangular wooden

yoke onto the bottom of which is attached the nozzle to be investigated. The nozzle points downwards, spraying into the sink so that, as it is turned on, the weight measured by the balance decreases and the change in weight can be recorded as the thrust of the nozzle. The hose delivering the water to the nozzle is brought in horizontally so that it does not effect the load on the balance as it becomes pressurised and therefore stiffer and slightly longer. Prior to use the system was checked by blocking off the jet's nozzle and pressurising the system; the apparent load on the balance increased by slightly over one gram.

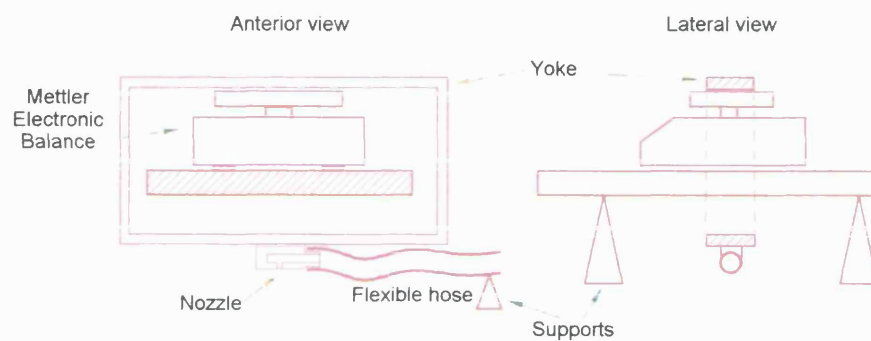


Figure 4.5 Apparatus used to measure the thrust produced for a given flow rate and pressure.

The nozzle was made in acrylic with a single hole of diameter 1.9 mm, length 5 mm and with a sharp edged inlet (coefficient 0.82) so that the effective area was $2.32 \times 10^{-6} \text{ m}^2$. The water pressure drop across the nozzle was 150 kPa and its flow rate was $41 \times 10^{-6} \text{ m}^3/\text{s}$. Substituting into $F = 2PA$ gives a predicted thrust of 0.70 N, whilst substituting into $F = \rho Q^2/A$ yields 0.75 N. In fact the measured thrust was 0.65 N, which is a good enough agreement to confirm the '2' in '2PA'. This discrepancy of 10 or 15% between theory and practice is encouraging given that this theory ignores the effects of viscosity and assumes perfect machining of all components.

4.2.2 Pressurised water supply.

Three different sources of pressurised water were used during the experiments. At first tap water was used. Since no accurate gauge was available, its pressure was measured by filling a sealed bottle connected to the tap so that the air in it was compressed and the pressure rose until it equalled that of the incoming water. The tap was then turned off and the volume of water in the vessel measured so that the proportion by which the gas was compressed was known and the tap pressure could be calculated using Boyle's law. The pressure was measured on several occasions and found to be 150 kPa above atmospheric. This was very constant as the tap is fed by a header tank on the roof.

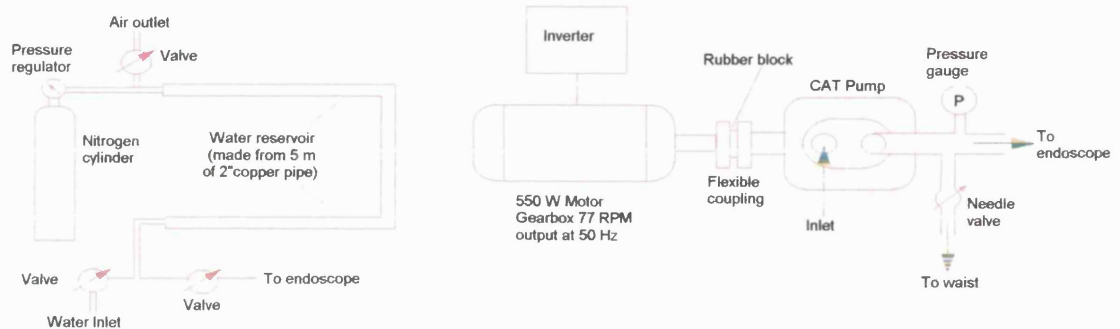


Figure 4.6 Left; compressed gas used to pressurise the water
Right; Piston pump and needle valve used to generate pressure.

Higher pressures were achieved using the 'soda siphon' illustrated on the left of Figure 4.6. The bursting pressure of a cylinder is inversely proportional to its diameter and to make economically a ten litre reservoir that could withstand a working pressure of up to 2 Mpa, a long but narrow piece of standard copper pipe (5 metres of 2" copper pipe) was used. This worked well but was cumbersome, needed refilling frequently and was extremely messy if a pipe joint burst or if the wrong valve was accidentally opened. The energy released by, for instance, a broken pipe would pose a considerable hazard if this type of pump was used during colonoscopy in humans. Safety considerations made it highly desirable to use a constant volume pump rather than a constant pressure pump so that a burst leads to an instantaneous loss of pressure with the same volume of water gently flowing out of the break as had been jetting through the nozzles.

An elderly industrial piston pump was therefore acquired. This pump (CAT Triplex Pump model 1011.1, “The pump with nine lives”) is rated to deliver up to 500 litres per minute at a pressure of up to 5 MPa. This stainless steel pump has three cylinders with a crankshaft that drives the pistons 120° out of phase with each other. One-way valves are used to regulate the flow of water into and out of the cylinders, so that the output has the characteristic shape of a rectified ‘three phase’ electric power supply. In most applications a sealed gas reservoir is added to the circuit to absorb high frequency spikes and smooth the three phase output in just the same way that an electric capacitor is used to smooth the output from an electronic rectifier. In our application this was not possible because of the desirability of having an extremely rapid loss of pressure in the event of a breakage.

The pump is coupled to a 500W electric motor and gear box with a rubber block that allows for misalignment of the shafts and provides electrical insulation between the electric motor and the water that might be in contact with a patient. To be patient safe this rubber block would need some simple modifications to prevent surface moisture from providing an electrical track.

It will be seen below that mounting the jets at the distal tip of an endoscope involves using lengths of small bore plastic tubing. The tubing and the fine nozzles provide a high resistance to flow, while the elasticity of the flexible plastic tubes provides a small capacitance. This resistance and capacitance helps damp down the fluctuations but, unfortunately, the CAT pump is designed for considerably higher flows than are desired here where the highest speed used is only 85 RPM (1.4 Hz). There is no obvious reason why some pressure fluctuation should affect the efficacy of a jet propelled endoscope, but it is a source of error when performing experiments, particularly as the pressure is measured at the pump’s outlet manifold where the fluctuations are at their greatest. Given the resources a smaller, faster running pump would be desirable.

4.2.3 *The relationship between thrust, the number of holes and the total cross sectional area of the holes.*

The object of this series of experiments was to confirm that even at diameters as small as 0.5 mm holes could be drilled in a sufficiently reproducible way that results obtained with one prototype could be applied to the design of the next. It was also intended to confirm that for a given water pressure the thrust generated was independent of the number of nozzles so long as the total cross sectional area remained constant.

A number of spray heads were made as illustrated in Figure 4.7. The heads were machined from acrylic rod and were mounted into apparatus similar to that illustrated in Figure 4.5. The CAT pump was used in the “constant pressure mode” - i.e. with the pump motor set to maximum speed and the needle valve adjusted to allow sufficient water to bleed off to produce the desired pressure.

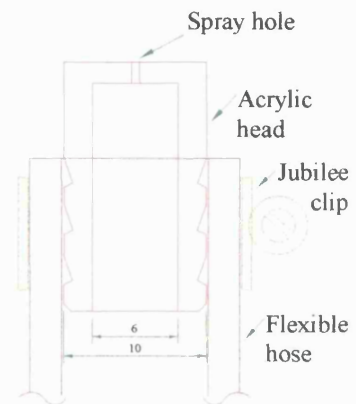


Figure 4.7 Spray head attached to a hose.

Table 4.1 presents the results from this series of measurements. The readings were very stable and to save time only one reading was taken for each configuration, however subsequently there was concern that the impression of stability and repeatability had not been confirmed. The apparatus was therefore reassembled and ten readings at nominally the same pressure were taken using a newly made spray head (3 holes each of 0.6 mm diameter). Between each test the needle valve was fully opened so that the water pressure in the nozzle fell to zero and then closed again until the pressure measured on the gauge on the pump outlet had returned to 12 Bar (the gauge was marked in Bars and these units have been retained, 1 Bar \approx 0.1 MPa). The mean thrust was 1.18 N ($n = 10$, $\sigma = 0.02$). This confirmed that the readings were repeatable and, allowing for the difference in pressure, was in reasonable agreement with the thrust that had been measured two years previously using a head with three holes of nominally the same diameter.

The first column shows that measurements are only slightly affected by pressure in the hose connecting the spray head to the pump. It can be seen that, with no water flowing, raising the pressure from nought to ten Bars increases the apparent weight of the spray head by only 0.04 N.

The next four columns show that as expected the thrust is proportional to the number of holes so long as the holes are of constant diameter; the thrust per square millimetre varies from 1.03 N to 1.12 N. The final four columns are to test whether the thrust depends on the total area of hole rather than diameter of the individual holes, and once again the thrust per square millimetre is reasonably constant ranging from 1.14 to 1.26 N.

No. of holes	0	1	2	3	4	1	2	4	8*
Diam. of holes (mm)	--	0.6	0.6	0.6	0.6	1.4	1.0	0.7	6x0.5 2x0.6
Total geometric area of hole, (mm ²)	0	0.28	0.57	0.84	1.13	1.54	1.57	1.54	1.74
Water pressure (Bar)	10	10	10	10	10	10	10	10	10
Flow rate (ml/sec)	0	6.8	16	24	31	45	44	47	53
Measured thrust (N)	-0.04	0.29	0.63	0.94	1.24	1.76	1.78	1.95	2.12
Thrust /unit area (N/mm ²)	--	1.03	1.11	1.12	1.10	1.14	1.13	1.26	1.22

* Nominally 0.5 mm holes, but subsequently found that a 0.6 mm drill could be slipped through two of them.

Table 4.1 Results of tests to show whether in practice thrust depends solely on the pressure and the total cross sectional area of the nozzles.

During these experiments certain shortcomings in the technique were apparent, the pressure gauge was crude, uncalibrated and marked in one Bar steps though, surprisingly, the sound made by the pump turned out to be very sensitive to pressure in this range so that reproducible results could be obtained. As mentioned above, the output of the pump is pulsatile and the gauge pressure was estimated (“guesstimated”) as the average value. Also, the softness of the acrylic meant that the diameters of the holes varied from the nominal size of the drills used while the radius of curvature of the entrance to the holes probably also varied. A more rigorous approach would have been

possible but the time involved did not seem worthwhile as these results are adequate to confirm the elementary theory as a rough guide. In any event the next section shows that estimating the pressure lost in the hoses and fittings in a jet propelled endoscope produces large errors.

4.2.4 The relationship between pressure and thrust for a prototype jet propelled endoscope

So far it has been assumed that all pressure drops result from accelerating the water through the nozzles and that no pressure energy is required to overcome the viscosity of the water. This has been reasonable because the tubes connecting the nozzles to the pump have not been very long (typically about ½ m) and have a large bore (8mm) compared with the nozzles. Such large tubing could not be used for a practical colonoscope and with smaller bore tubing and fittings the pressure dropped upstream of the nozzles becomes significant.

If the flow in a tube is lamina then the pressure drop across the tube is caused by viscous drag between the water and the tube wall. It can be calculated using Poiseuille's law;~

$$\Delta P = 8 \eta L Q_{vol} / (\pi r^4)$$

Where ΔP = pressure drop across the tube

η = dynamic viscosity

Q_{vol} = volume flow rate

L = length of tube

r = radius of tube

In the present application the water in the small bore tubes has a high velocity and there are various fittings and bends so that the flow may not be lamina in which case the pressure drop is considerably greater than that suggested by applying Poiseuille's law. The Reynold's number is the ratio of the dynamic to the viscous forces and it can be used to predict whether flow in a tube will be lamina or turbulent; below about 2000 the flow is lamina but above that it begins to break up and become turbulent⁵.

$$Re = \rho.v.d/\eta$$

Where Re = Reynold's number
 ρ = liquid density
 v = mean water velocity
 d = tube diameter
 η = dynamic viscosity

The consequences of pressure drops in the tubing and fittings can be seen in Figure 4.8. These experiments were carried out using the prototype endoscope described in section 4.2.2. and the water was pressurised with compressed gas as illustrated in Figure 4.6 . It can be seen that the thrust produced is directly proportional to the pressure developed at the pump for a given cross sectional area of the nozzles. It had been expected that increasing the number of holes and the total cross sectional area would increase the thrust but the experiments showed that this was not the case. The explanation for this is that when the cross sectional area is increased the volume flow through the system increases so that more pressure is lost along the tube and fittings and less is left to accelerate the water through the nozzles.

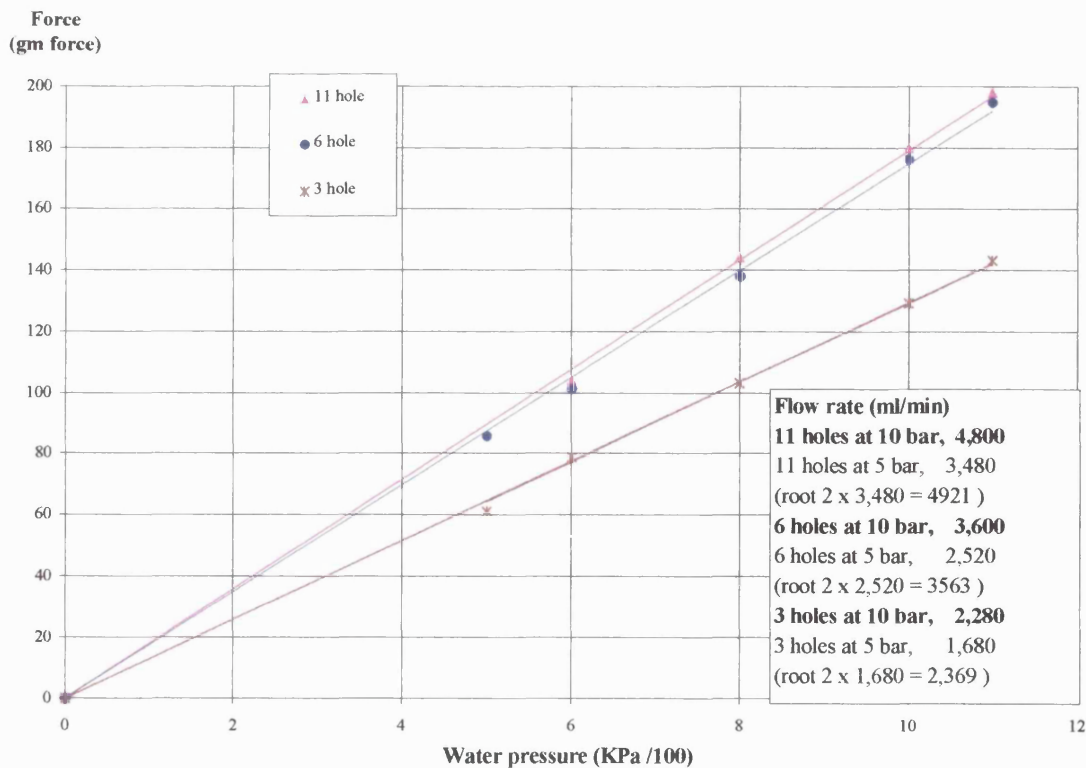


Figure 4.8 Thrust, pressure and flow for three different cross sectional areas of nozzle. All holes were 0.75 mm diameter.

It is possible to use these results to estimate the ratio of the pressure used to accelerate the water through the nozzles to the pressure dropped through the tube and fittings.

Let $P_{h,n}$ = Pressure drop across nozzle holes for a head having n nozzles ('h' for holes) at a flow rate of 3,600 ml/min.

$P_{t,n}$ = Pressure drop across tubes etc. for a head with n nozzles ('t' for tubes) at a flow rate of 3,600 ml/min.

P_n = Pressure drop across whole system; i.e. gauge pressure at the pump at a flow rate of 3,600 ml/min.

F_n = Force per hole for a head having n holes at a flow rate of 3,600 ml/min.

From the data presented in the above

$$P_6 = 10 \text{ bar and } F_6 = 1.8/6 = 0.3 \text{ N.}$$

Based on the square root relationship between flow and pressure (section 4.2)

interpolation gives;

$$P_{11} = (3600/3480)^2 \times 5 = 5.35 \text{ bar.}$$

Interpolating this pressure into the above graph gives;

$$F_{11} = 5.35 \times 18 / 11 = 0.09 \text{ N.}$$

By definition $P_n = P_{h,n} + P_{t,n}$

So $P_{11} = P_{h,11} + P_{t,11}$ and $P_6 = P_{h,6} + P_{t,6}$

But since the flow rate is the same, $P_{t,11} = P_{t,6}$

So $P_{11} - P_{h,11} = P_6 - P_{h,6}$

Substituting $5.35 - P_{h,11} = 10 - P_{h,6}$ bar

$P_{h,11} = P_{h,6} - 4.65$ bar

All the holes are nominally the same size (0.75 mm) and the relationship between force and the number of holes is linear, so for each head the ratio $P_{h,n} / F_n$ is constant and the same.

Let $P_{h,n} = k \times F_n$

So (1) $P_{h,6} = k \times 0.3$ bar

$$\begin{aligned} \text{and} & \quad P_{h,11} = k \times 0.09 \quad \text{bar} \\ \text{but from above} & \quad P_{h,11} = P_{h,6} - 4.65 \quad \text{bar} \\ \text{Therefore (2),} & \quad P_{h,6} - 4.65 = k \times 0.09 \end{aligned}$$

Solving (1) & (2) simultaneously

$$\begin{aligned} P_{h,6} &= 6.65 \quad \text{bar} \\ P_{t,6} &= P_6 - P_{h,6} = 10 - 6.65 = 3.35 \quad \text{bar} \\ P_{h,11} &= P_{h,6} - 4.65 = 2 \quad \text{bar} \\ P_{t,11} &= P_{11} - P_{h,11} = 5.35 - 2 = 3.35 \quad \text{bar} \end{aligned}$$

This shows that with six holes about 65% of the pressure is dropped across the holes, while with eleven holes more than half the pressure is lost in the tubing and connectors with only 37% being used to drive the water through the nozzles. Applying the same approach to the three hole head suggests that it uses 87% of the pressure across the nozzles.

For this endoscope the water is delivered through the biopsy channel which is about 1.3 m long and has a radius of 1.5 mm so that when the flow is 60 ml/s the water's mean velocity is 8.5 m/s. Taking the water temperature as 20° C so that its viscosity is⁶ 1.00 x 10⁻³ Pa.s, the Reynold's number is found to be 2.5 x 10⁶ which means that the flow will be turbulent. This turbulence explains the failure of Poiseuille's law, which predicts a pressure drop of 39 kPa (0.39 bar) that is only a little more than an eighth of the actual pressure drop.

4.3 The Design and Construction of Prototypes.

During this project many prototypes were designed and built and only the most significant will be discussed here. For convenience they will be described in chronological order.

Before starting to design a prototype it was necessary to decide whether to build an endoscope from scratch so that it could be optimally suited to being propelled by a water jet or whether to design a jet system that could be attached to an existing endoscope. In order to assess the practicality of building an endoscope, some days were spent in designing and building miniature optics (using a graded index lens) and a simple steering system. The optics worked unexpectedly well but the steering system was stiff and prone to breaking. The emphatic conclusion from this exercise was that if at all possible the jet propulsion should be an add-on to an existing endoscope.

4.3.1 High Pressure Over-tube.

The initial idea was to fit a high pressure tube over the endoscope so that water could be pumped up the annulus between the endoscope and the tube (Figure 4.9).

It was difficult to find a supplier of a very flexible high pressure tube of the right diameter, so one was made. This was done by sliding a length of silicon rubber tube (ID 10 mm, OD 14 mm) onto a rod that could then be mounted on a lathe so that 'Dacron' fishing line could be wound helically around the tube with a pitch of 2 mm. The winding was then repeated in the opposite direction to produce a braid and finally the outside of the tube was then painted with an RTV silicone rubber. Removing the tube from the rod required patience, massage and compressed air. The reinforced tube was fitted with appropriate end pieces incorporating 'O' ring seals, mounted onto a paediatric endoscope and pressure tested up to 800 kPa.

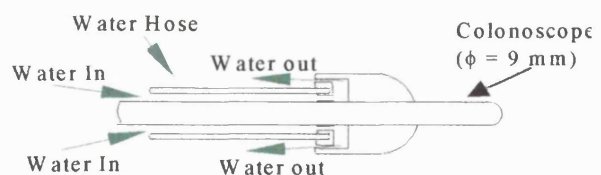


Figure 4.9 The high pressure over-tube.

Unfortunately, tests of steering the endoscope as it propelled itself around a sink made clear what should have been apparent from the start; that the jets are much more effective if they are at the very tip of the endoscope beyond the steering section so that the thrust pulls the endoscope in the direction in which the tip is pointing. This meant that the over-tube had to cover the steerable portion of the endoscope which can bend with a radius of as little as about 50 mm and is operated by a delicate mechanism. It seemed most unlikely that a sufficiently flexible over-tube could be made and so this approach was abandoned in favour of pumping the water through the inside of the endoscope.

4.3.2 Dual Channel Endoscope.

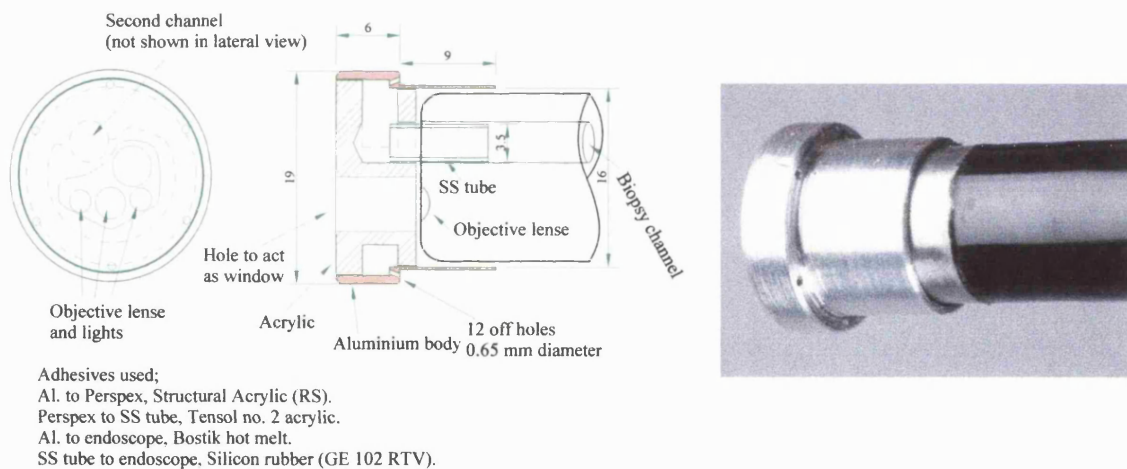


Figure 4.10 Dual Channel Endoscope with acrylic and aluminium head.

An elderly and broken Olympus TGF 2DD endoscope with two biopsy channels was available and it was used to build a prototype jet propelled endoscope. The water was pumped to the nozzles via the larger of the biopsy channels so that the handling of the endoscope was not significantly affected and its diameter was only increased at the tip and there only by a couple of millimetres. As can be seen in Figure 4.10, the head was made from three components glued together with structural acrylic adhesive. The core was made from acrylic to facilitate machining, but the outer skin that was too thin to be acrylic and so was made from aluminium. The bond between the acrylic and the

aluminium was under tension when the system was pressurised and there was a tendency to leak unless the components fitted together tightly and were scrupulously cleaned prior to gluing. This meant that the heads were difficult to make and once made could not be disassembled and modified.

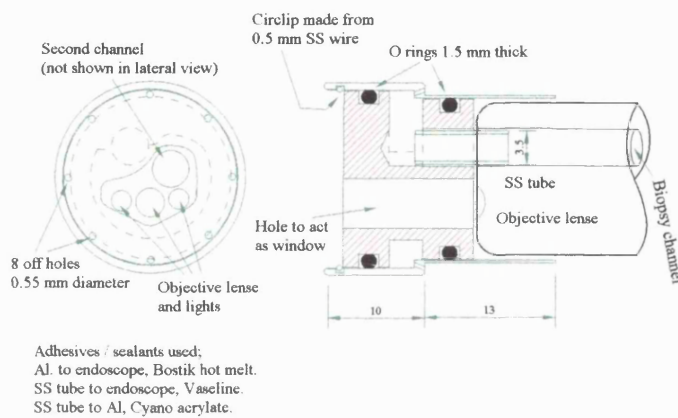


Figure 4.11 Dual Channel Endoscope and head with aluminium skin and core

A later version of the head (Figure 4.11) overcame these problems by using ‘O’ rings to make a mechanical seal between an aluminium core and an aluminium skin with a circlip to retain the core in the correct position. This arrangement was well suited to an early stage prototype, providing excellent sealing and allowing easy dismantling and modification. However visiting clinicians did not like it because

the extra length meant that the optics looked out through a long aluminium tunnel that considerably limited the field of view and the circlip arrangement looked (and was) dirty and sharp.

4.3.3 Endoscopes with external tubes

Using a tube within the body of the endoscope is the best way of supplying water to the nozzles, but the biopsy channels of current endoscopes are not intended to withstand high pressure liquids and some water leaked from the channel into the body of the scope where it got into the fibre optic bundles. This is a known problem with endoscopes and when it happens the surface tension of the water prevents the individual optic fibres from sliding over each other with the result that, as the bundle is flexed, fibres are stretched and become broken.

To overcome this problem it was reluctantly decided to supply the water to the head with tubes external to the endoscope. The requirement for these tubes is that they should be;~

- Sufficiently flexible not to significantly stiffen the endoscope.
- Biocompatible to a degree acceptable for short term use in the bowel.
- Kink resistant.
- Capable of withstanding the maximum pressure (say 50 bar, 5 MPa) without bursting or stretching significantly.
- Large enough internal diameter to avoid “too much” loss of pressure.
- Smallest possible outside diameter (i.e. thinnest wall).
- Low coefficient of friction with the bowel wall.
- A material that can be bonded to the jet head

The requirement for strength with a thin wall ruled out unreinforced rubbers or plasticized PVC and we were unable to find suppliers for short lengths of small diameter, braid reinforced rubber tube. Polyethylene, polypropylene and PTFE tubes are prone to kinking and difficult to bond to. For a time polyimide tubing with a diameter of 2 mm, a wall thickness of 0.05 mm and a minimum bend radius of 50 mm looked hopeful but once delivered it was clear that this bend radius could only be achieved with very careful bending as otherwise the tube kinked. In the end Nylon 11 (a flexible grade) tubing made by Portex was chosen as the best compromise and has proved satisfactory.

The requirement to avoid “too much” loss of pressure was indeterminate as the rate at which water was required was unknown and the pressure required at the head was also unknown. As a preliminary estimate, a flow rate of 50 ml/s with an allowable pressure drop along the tubing and fittings of 10 bar was used. Even these values were of little use since it was suspected that Poiseuille’s formula would not be applicable and so two diameters of tubing were obtained; Portex 24524 412 5 (ID 2.5 and OD 3.2 mm) and Portex 1425245 42 4 (ID 1.5 and OD 2.0 mm).

Figure 4.12 shows a jet head that was built using the larger bore tubing. It is immediately apparent that the head has changed a thin endoscope (ϕ 9 mm) into a fat one (ϕ 19mm). There is also the inconvenience of a pair of Nylon tubes snaking around.

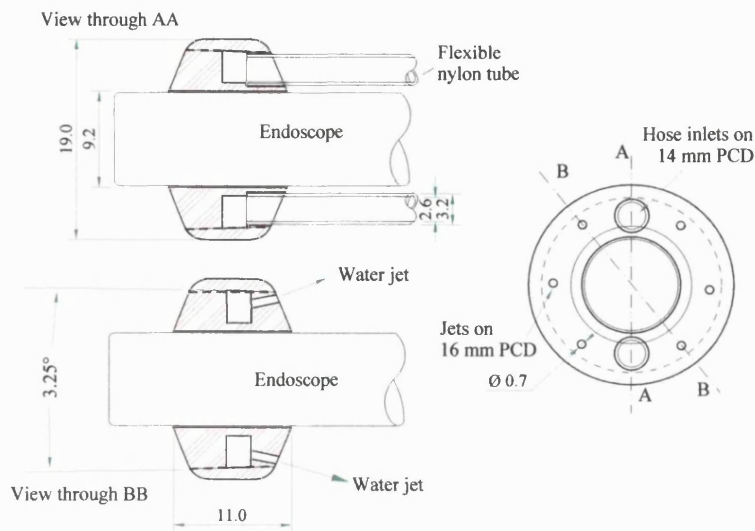


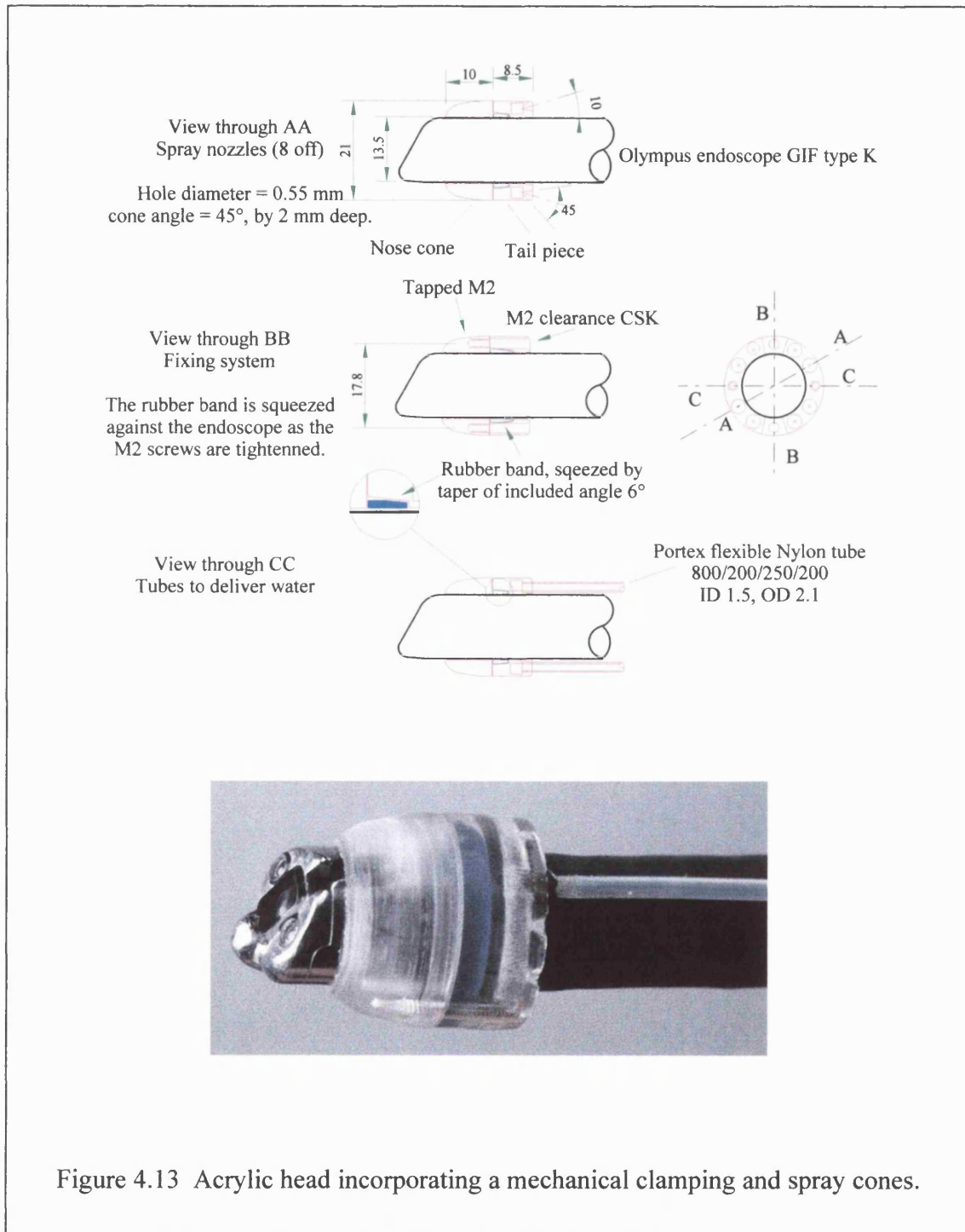
Figure 4.12. Acrylic head with two external supply tubes.
The photo shows a paediatric endoscope being pulled vertically upwards.

The body is made from two tapered acrylic components that can be pushed together and solvent welded along the dashed line in Figure 4.12. The flexible nylon tubes are roughened and glued to the acrylic with a “water proof” epoxy (Loctite Super Steel epoxy) and, as before, the head is attached to the endoscope with Bostik hot melt adhesive.

4.3.4 Mechanical clamping to the endoscope.

These heads were attached to the endoscope using a ‘hot melt’ adhesive with a softening temperature of about 50°C, so that they could easily be removed by dipping into hot water and then gently pulling. The remaining glue could be rubbed off the endoscope leaving no visible trace. This technique worked well but Olympus warned that the video cameras in modern endoscopes are destroyed if heated above 60°C and that it would take many months to gain approval from Olympus in Japan to use any adhesive in contact with the proprietary lacquer that coats their endoscopes. It was therefore decided to change to a

mechanical clamping system where a cap on the front of the head pushes a rubber ring into a tapered annulus so that it is squeezed against the shaft of the endoscope (see Figure 4.13) and grips it tightly. (This Figure also illustrates the “spray cones” that are described in a subsequent section).



4.4 Results with prototype endoscopes.

The results with these prototypes were dramatic to watch but of dubious scientific value. The problem was that by increasing the pressure or flow rate any desired thrust could be obtained and, with only our instincts to rely on as to what felt safe, there was no clear cut upper limit to these parameters. The endoscope shown in Figure 4.12 performing the Indian rope trick did this by producing a thrust of 3.2 N, which required a flow of 85 ml/s driven by a gauge pressure at the pump of 27 Bar.

The largest thrust that was produced was 4.5 N with the aluminium head illustrated in Figure 4.11 with the holes enlarged to 0.75 mm diameter and with a flow rate of 100 ml/s (pump pressure about 30 Bar).

A slightly modified version of the force measuring apparatus illustrated in Figure 4.5 was used to record the thrusts generated by the various prototypes and the general conclusion was that a thrust of about 2.5 Newtons could be produced with flow rate of 50 to 60 ml/s through eight 0.6 mm diameter holes and that this flow *felt safe and appeared* to be manageable so long as it was used for intermittent bursts of two or three seconds each, with time then allowed to suck out the water.

The conclusion from these results was that the approach appeared encouraging but that safety issues regarding the cutting power of the jets needed to be investigated. This investigation and the consequent changes to the design are described in section 4.5 and 4.6.

4.4.1 Tests with model colons

The models that were built for this project are described in Appendix 1. Some bits of that appendix are duplicated here.

To test whether this thrust would be helpful two models were constructed which were difficult to endoscope with a conventional instrument. The simpler of the models, illustrated

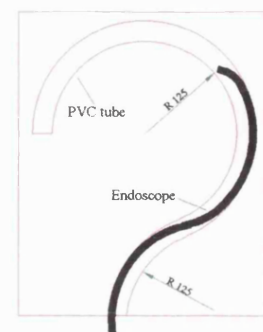


Figure 4.14
The question mark
model colon.

in Figure 4.14, used a length of transparent PVC tube (ID 1" and OD 1¼") that was pushed into a question mark shaped slot milled in a wooden board. When the endoscope was pushed around the loop its shaft would stick against the walls of the tube and become jammed so that harder pushing simply locked the endoscope more firmly in place. A short blast from the jets would pull the shaft free from the wall and allow the endoscope to be pushed further around the question mark.

A more realistic looking latex rubber model was constructed as follows. A 70 cm length of corrugated steel 'flexible' vacuum tube was bent into an artists impression of a colon from the anus to midway across the transverse colon. This was then covered with lagging from a plumbers merchant which was itself bound with a self adhesive scrim and then a layer of plaster impregnated bandage. Once hardened the plaster was painted with PVA adhesive to make a non-porous surface which was painted with three coats of latex (MR Revultex supplied by Regent). The rubber colon was then unrolled from the model like an elephantine condom and, once unrolled and placed on a wooden board, strips of rubber were glued to it to hold it in place on the board and simulate mesenteries.

Even when lubricated with KY jelly the inside of this 'colon' had an unrealistically high coefficient of friction that made it impossible to traverse with a conventional endoscope, although it was encouraging to note that the difficulties encountered were like an exaggerated version of the problems associated with a real human colon. With a jet propelled endoscope such as that illustrated in Figure 4.11 it was possible but difficult to progress the entire length of the model. Regrettably, the paediatric endoscope used with the head illustrated in Figure 4.12 could not be used as its steering mechanism was broken, which was why it had been made available to the project in the first place.

An unexpected problem arose when using the jets inside the rubber 'colon': the jets of water entrained air and acted as a Venturi pump that sucked the air from in front of the endoscope and caused the 'colon' to collapse onto the acrylic head so that further progress could not be made. On investigation it turned out that pressure developed by this Venturi pump is only a little over 5mm H₂O which was not significant in relation to the pressure normally used to insufflate the colon during colonoscopy. The problem had appeared worse than it was because the model colon had no 'sphincter' at its anus to stop air escaping.

5.4.2 Tests in vivo

The aluminium head illustrated in Figure 4.11 was used with a flow rate of 83 ml/s (5 l/min at a pump pressure of about 20 Bar) for an *in vivo* experiment with a large pig. The endoscope proceeded rapidly along the bowel at about 50 mm/s with only slight pushing and the water also proved most effective at flushing out the copious contents of the rectum and colon. The endoscope was inserted up to the hilt (900 mm) and then gently pulled out before the pig was culled and the colon excised, washed and inspected. No damage was visible on the mucosa and there were no perforations.

On two subsequent occasions attempts were made to use the head illustrated in Figure 4.12 with live pigs but on both occasions the pig had been starved for forty eight hours and the faeces in the rectum and colon had become hard so that they did not easily wash out. In the end about 300 mm proximal to the anus was cleared by using the endoscope with the flow at 85 ml/s as a kind of “Dynorod”. The only encouraging conclusions that could be drawn from this debacle were that the waste water flowed harmlessly out of the anus and could be easily collected and that despite pulling and pushing the endoscope back and forth along the bowel about a dozen times the bowel was not seriously damaged although considerable redness and soreness could be seen.

5.5 Safety considerations relating to bursting and perforation of the colon

It was apparent from the preceding results that it was necessary to investigate the danger that the colon might be perforated by the water jets. Simply judging what was acceptable by feeling the force from a jet on a finger was not sufficient. An indication of the strength of the bowel can be found from the literature, most of which concerns accidents resulting from over inflating the colon.

4.5.1 Bursting of the colon.

Applying excessive pressure to the colon can cause it to burst and as far back as 1931 the American doctor Con Amore V Burt (is this really his name or did he just sign himself “With love, V. Burt”?) published a lengthy but entertaining paper⁷ describing 40 clinical cases of colons being burst by over inflation, 36 of which were “the result of practical jokes” with compressed air lines, three were accidents with air lines, and one was self inflicted with a bicycle pump! The introduction of colonoscopy produced a legitimate reason for inflating the bowel and a number of articles have described “air-pressure-induced colon injury during colonoscopy”.^{8,9,10,11,12,13} Pressure is also applied to the colon wall by the tip or shaft of the endoscope being pushed against it and this may cause a perforation (see for example Orsoni et al¹⁴ or Damore et al¹⁵).

Photographs of serosal tears caused by over inflation show that the tears are longitudinal indicating that they are caused by excessive hoop stress as would be expected from the elementary mechanics of the stresses in pressure vessels¹⁶.

Consider the colon as a tube with closed ends;

Length = L
 Diameter = ϕ
 Inflated pressure = P
 Hoop stress = σ_H
 Axial stress = σ_A
 Wall thickness = t

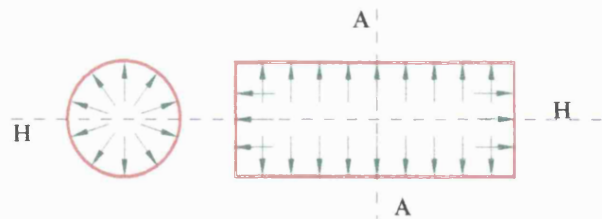


Figure 4.15 The colon represented as a tube with closed ends.

Consider first the hoop stress, σ_H

Let the tube be notionally cut in half along the line HH.

The force pushing the two halves apart = $P \times (\phi \times L)$

The cross sectional area of the wall resisting this = $2 \times (t \times L)$

Therefore $\sigma_H = P \times \phi / 2t$

Consider next the axial stress, σ_A

Let the tube be notionally cut in half along the line AA.

The force pushing the two halves apart = $P \times (\pi\phi^2/4)$

The cross sectional area of the wall resisting this = $t \times \pi \phi$

Therefore $\sigma_A = P \times \phi / 4t$

This analysis ignores the decrease in wall thickness as the tissue stretches, but fortunately the figures presented in Table 4.2 are for “breaking load per unit width” rather than breaking stress and so avoid the issue of the change in thickness. The tensile load per unit width is the stress multiplied by the wall thickness.

It can be seen that the hoop stress is twice as large as the axial stress and that the larger the diameter the larger the stress which accounts for the tendency for longitudinal tears to occur at the wider parts of the colon. Table 4.2 shows that the importance of hoop stress is compounded by the anisotropic properties of the colon wall which makes it stronger in the longitudinal direction.

Age (years)		0-9	10-19	20-29	30-39	40-49	50-59	60-69	70-79	Adult Average
Ascending colon	Longitudinal	102	130	113	97	89	82	71	66	83
	Transverse	89	109	98	88	80	75	68	65	77
Transverse Colon	Longitudinal	108	131	113	97	91	85	74	69	85
	Transverse	82	91	78	66	57	55	46	41	55
Descending Colon	Longitudinal	133	154	135	118	115	108	94	89	107
	Transverse	81	75	66	56	50	43	33	28	43
Rectum	Longitudinal	198	209	184	164	151	130	113	108	137
	Transverse	130	137	121	108	92	82	74	70	88
Average	Longitudinal	135	156	136	119	112	110	88	83	103
	Transverse	96	103	91	80	70	64	55	51	66
Ratio	Longitudinal	0.86	1.00	0.87	0.76	0.72	0.70	0.56	0.53	
	Transverse	0.93	1.00	0.88	0.78	0.68	0.62	0.53	0.50	
	Average	0.90	1.00	0.88	0.77	0.70	0.66	0.54	0.52	

Table 4.2 Tensile breaking load per unit width of human large intestine in g/mm reproduced from Strength of Biological Materials¹⁷ (1 g/mm ≈ 10 N/m)

The figures in Table 4.2 can be used to estimate the bursting pressure of human colon;~

$$\begin{array}{ll} \text{From above,} & \sigma_H = P \times \phi/2t \\ \text{Rearranging} & P = 2t\sigma_H/\phi \end{array}$$

Taking the value for breaking load for the transverse colon in the “transverse” direction as about 650 N/mm (66g/mm = 647 N/m) and taking the transverse colon’s diameter as 0.08 m this implies a bursting pressure of about 16 kPa which is in remarkably good agreement with the figure of 2.20 psi (= 15.7 kPa) for producing serosal tears which Burt found in 1931¹⁸ when he used compressed gas to pop a series of post mortem sections of human gut. The closeness of the agreement between the estimated and the calculated pressure is somewhat fortuitous as Burt’s figure is an average of samples taken from 18 cadavers with a range from 6.08 psi to 0.76 psi.

What are the implications of this analysis for the water jet propelled colonoscope? It is obvious that care must be taken not to flood the colon with pressurised water as the 20 bar (2 MPa) delivered at the pump head would be more than enough to burst the colon. This requirement could be met by limiting the time for which the jet is powered to, say, less than two seconds so that only about 150 ml is sprayed. It would then be necessary to ensure that before it is fired again excess pressure is released and water removed through the biopsy channel or a separate suction tube. The introduction of this volume of water into the colon would not significantly raise the intraluminal pressure so long as the water jet is not trapped inside a sealed pouch of tissue. The possibility that the tip of the endoscope was trapped could be tested by, for example, introducing a bolus of air or water just prior to firing the jets and ensuring that the pressure decays rapidly. This could be monitored at the proximal end of the water supply tubes without the inconvenience of placing a pressure sensor at the tip of the endoscope.

4.5.2 Perforation of the colon

A much more serious threat is that the force applied by the jets of water as they strike the wall of the colon will cut through it in the same way that ultra high pressure jets are used industrially to cut metal.

It was encouraging that jets from the prototypes did not feel sharp to the hand, however the wall of the colon is far weaker than skin on your hands and this might not be a reliable feeling. It was also encouraging that experiments with *in vivo* and excised porcine colons had shown no visible damage although, once again, there was concern that these experiments had only involved jets striking the colon wall at a glancing angle whereas in some circumstances the jet might be perpendicular to the wall or, even worse, normal to a diverticulum.

The force required to perforate the colon with a jet of water can be analysed in a similar way to the bursting pressure. It is assumed that all the water in the jet stream is travelling at the same velocity so that when it strikes a surface the momentum force per unit cross sectional area of the stream is constant.

Figure 4.16 shows a jet impinging on a membrane;

Let the total thrust of the jet = F
 diameter of the jet = ϕ
 membrane thickness = t
 momentum per unit cross sectional area of the jet = P
 tensile stress in the membrane = σ

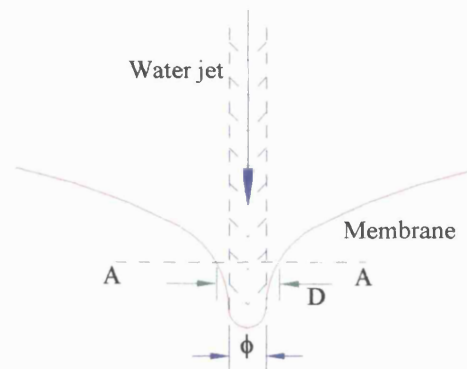


Figure 4.16 A jet of water striking a membrane perpendicularly.

Consider a horizontal section through the membrane cut along the arbitrary line AA and let the diameter of the cut = D

If $D > \phi$ then

$$\text{Jet force pushing down} = F = P \times \pi \phi^2 / 4$$

$$\text{Consequent Tensile force in membrane at AA} = \sigma t \times \pi D$$

Equating these and rearranging

$$\sigma_t = \frac{P \times \pi \phi^2 / 4}{\pi D}$$

It can be seen that ' σ ' is inversely proportional to ' D '.

If $D < \phi$ then

Jet force pushing down =

$$P \times \pi D^2 / 4$$

Consequent Tensile force in membrane at AA = $\sigma_t \times \pi D$

Equating these and rearranging
$$\sigma_t = \frac{P \times \pi D^2 / 4}{\pi D} = P \times D / 4$$

It can be seen that ' σ ' is proportional to ' D '.

So the stress is at a maximum when $D = \phi$

Substituting ' F ' for ' $P \times \pi \phi^2 / 4$ ' and rearranging
$$F = \pi \phi \times \sigma_t$$

From Table 4.2 the strength of the descending colon in the transverse direction of a 70 – 80 year old is selected as the worst case;

$$\sigma_t = 28 \text{ gram/mm}$$

Taking the diameter of the jet as typically 0.7 mm;

$$\pi \phi = 0.7 \times \pi = 2.2 \text{ mm}$$

$$\text{So } F = 2.2 \times 28 = 62 \text{ gram} = 0.6 \text{ N}$$

i.e. in the worst case the thrust from a jet of 0.6 mm diameter should be less than 0.6 N if it is not to perforate the colon wall.

From section 4.2;
$$F = 2P_H A$$

Where F = thrust from jet

P_H = Pressure drop across the hole (NOT the same as P above, the momentum per unit cross sectional area)

A = effective area of hole

In this case $F = 0.6 \text{ N}$ and $A = \pi \phi^2 / 4 = 3.8 \times 10^{-7} \text{ m}^2$

So $P_H = F/2A = 779 \text{ kPa} \approx 8 \text{ Bar}$

In other words the pressure drop across the nozzle should not exceed 8 Bar. It can be seen from section 4.1.4 that for a head with six holes of 0.75 mm diameter this would correspond to a gauge pressure of about 12 bar at the pump.

4.5.3 Perforation of the colon – experiment

The analysis presented above suggests that a jet of water striking a flexible membrane will have much the same effect as a steel rod with the same diameter and a rounded end being pushed into the membrane with the same force. To test this four metal rods of diameters 1, 2, 3 and 4 mm were prepared with smoothly domed (hemispherical) ends and a membrane holder was made as illustrated in Figure 4.17. This consisted of an acrylic pot with a tapered rim over which was stretched the membrane to be tested, the membrane was then tightened and clamped in place with a tapered ring. When colon wall was used as the membrane, the ring tended to slide upwards and had to be held down with adhesive tape.

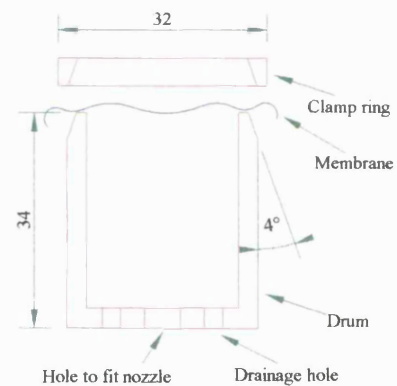


Figure 4.17 Membrane holder.

This drum was then placed on the pan of an electronic weighing scale (Mettler PM 2000) which was itself placed on the bed of a milling machine directly under the chuck which held the metal rod. The bed was then slowly raised so that the metal rod depressed and then broke the membrane. Each time the bed was raised it had to be left until the load recorded had become reasonably stable which made the procedure very lengthy and it was also rather arbitrary as to what constituted ‘reasonable stability’. Since, in practice, the water jet would not be pointed at the same spot for more than a few seconds ‘reasonable stability’ was defined as “changing at less than ½ % per second”. Results obtained with this rig are shown in Table 4.3.

	Rod ϕ 1 mm	Rod ϕ 2 mm	Rod ϕ 3 mm
0.1 mm thick latex membrane, cut from glove			
Load at perforation, test #1	3.5 N	6.2 N	10.3 N
Load at perforation, test #2	3.4 N	6.3 N	10.1 N
Load at perforation, test #3	3.5 N	6.5 N	10.2 N
Porcine colon			
Load at perforation, test #1	1.3 N	3.3 N	4.4 N
Load at perforation, test #2	1.5 N	3.8 N	5.2 N
Load at perforation, test #3	-	3.5 N	5.4 N

Table 4.3 Force required to perforate membranes with various plungers.
(the lack of a value for colon, test # 3, 1 mm rod is an oversight)

It can be seen that the results for the latex membrane are consistent and reasonably linear, while those for tissue have more variability though they are still broadly linear as predicted by the equation " $F = \pi r^2 \times \sigma$ " (see two pages above) when the stress and thickness are constant.

These tests were carried out using porcine colon that had previously been frozen and there was concern that its mechanical properties might differ from those of fresh colon even though it felt and looked the same as it had before freezing. It was therefore decided to compare its bursting strength with published values for fresh colon. The bursting strength was measured by tying off a 15 cm length of colon to form a 'sausage' into one end of which a PVC tube was inserted. The other end of the tube was placed in a beaker to form a siphon so that as the beaker was slowly raised the pressure in the sausage was increased.. The head of water required to burst the sausage was found to be 1.7 m (≈ 17 kPa). This value can be compared with the results found by Kozarek et al¹⁹ when they used air to rupture isolated colon segments in four pigs *in vivo* and found the mean pressure to be 143 mmHg (19 kPa) in the sigmoid and descending colon, 122 mmHg (16 kPa) in the transverse colon, 73 mmHg (10 kPa) in the ascending colon and 108 mmHg (14 kPa) in the caecum. The present author has observed the removal of the colon from several pigs and does not understand how terms such as "transverse colon" can be applied to the convolutions of the porcine colon. In any event it appears that defrosted colon has approximately the same strength as *in vivo* colon.

Shortly before the serosa tore, when the water head was already 1.7 m, the diameter of the colon was measured to be 35 mm. From section 4.5.1 above it can be seen that

$$\sigma_H = P \times \phi / 2t.$$

Therefore the tensile breaking load per unit width (i.e. stress x wall thickness) is given by

$$\begin{aligned} \sigma_H \times t &= P \times \phi / 2 \\ &= 17 \times 0.035 / 2 = 0.298 \text{ kN/m} \approx 0.3 \text{ N/mm} \\ &\approx 30 \text{ g/mm} \end{aligned}$$

For a plunger of diameter $\phi = 1 \text{ mm}$ this implies a load at perforation of $\pi \times 0.3 = 0.94 \text{ N}$ ($\approx 94 \text{ g}$) which compares with the 1.3 and 1.5 N values presented in Table 4.3 above. This is reasonable agreement considering the experimental problems associated with making measurements on a material that is so prone to creeping and that the samples came from different parts of different colons. It can be speculated that the cause of the difference is that the plunger tests the strength at a single point whilst the inflation test finds the weakest point on the sausage skin.

The drum illustrated in Figure 4.17 was then set up as shown opposite so that the metal plunger was replaced with a water jet. Figure 4.18 reproduces a photo of a jet from a nozzle striking a latex rubber membrane.

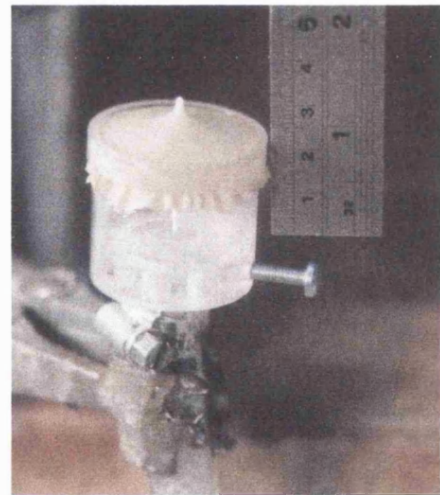


Figure 4.18 Photo of a 0.5 mm water jet striking a rubber membrane.

When the gauge pressure at the pump was 20 bar and a nozzle of 0.7 mm diameter was used, the membrane held for a few seconds and then burst. Assuming a linear relationship between pressure and force, the force was $1.95/4 \times 20/10 \approx 1 \text{ N}$. Scaling from 0.7 to 1 mm diameter implies equivalent load 1.4 N. Less than half that measured with the 1 mm plunger.

With porcine colon being struck by a jet from a 1 mm nozzle, the serosa perforated after about ten seconds when the pressure was set to six bar. At seven bar the colon perforated in about a second while at five bar the serosa held but the mucosa was almost instantly punctured and a blister was produced. From Table 4.1 it can be seen that six bar corresponds to a force of $1.78/2 \times 6/10 = 0.54$ N, which once again is considerably less than predicted, only about one third of the force required by a metal plunger. This result was not significantly altered when saline was used in place of tap water, confirming that the water was not causing lysis of the cells.

It was difficult to see exactly what happened as the water struck the tissue but it appeared that it tunnelled its way through first piercing the mucosa and producing blistering before displacing the muscle layer and finally pushing through the serosa without producing such a marked pinnacle as had been seen with the plungers. It seemed possible that the high pressure and highly turbulent water was affecting the structure of the colon wall.

In any event it was apparent that the simple theory presented in section 4.3.1 provides no more than a very rough guide and that whether for mechanical or chemical reasons a jet of water is more destructive than a metal bar of the same diameter, pushed with the same force. Rather than continue with these time-consuming and not very satisfying tests it was decided to try to design a nozzle that would overcome these problems by atomising the spray so that its force was spread over a much larger geometric area.

4.6 The design of nozzles to produce high velocity atomised sprays.

Introduction

Atomisation of a liquid stream occurs when oscillations cause the break up of a jet or sheet of water into a stream of particles, the purpose of an atomiser is to achieve this in a consistent manner for the range of velocities and pressures encountered. Breaking up the stream of water requires energy because of the increase of the surface area but only a very little energy is required and for conventional atomisers this is a tiny fraction of the energy used. Bayvel and Orzechowski state that “for all traditionally used atomizers the efficiency is very small, namely $\eta < 0.1\%$ ”²⁰, where ‘efficiency’ is defined as

$$\eta = \frac{Ea}{Ea + Ek + El}$$

Where Ea = energy of atomisation (surface energy)
 Ek = kinetic energy
 El = energy lost to friction

It is fortunate that this definition is almost the opposite of that required for jet propulsion where the kinetic energy is the desired output to be maximised.

The background to this section of the thesis comes from the book ‘Liquid Atomization’ by Bayvel and Orzechowski²⁰. This is an introduction to the practice and theory of atomiser nozzle design. One of the authors works in London while the other is at Łódź and it is hard not to see the contrast between British empiricism and Continental analytical theory in the chapters which are either verbal descriptions with pen and ink drawings or mathematics. The mathematical theory need not concern us here as it deals almost entirely with droplet size which is the key parameter in the design of atomiser nozzles for boilers, diesel engines and such like. Also, the theory is of little use with high velocity jets; “up to now there is no theory for disintegration at a high velocity of liquid discharge; therefore an answer does not exist to the fundamental question – what spectrum of drop diameters can be obtained under given conditions?”²¹

Figure 4.19 shows the behaviour of a liquid as it emerges from a jet nozzle at high speed and three distinct zones can be seen: initially in the compact jet zone (AB) the course of the liquid is much as it had been in the nozzle but interactions with the surrounding air set up oscillations which cause the stream to break up in the disintegration zone (BC) until finally it consists of fine droplets in the drop zone (CD). The length of the compact zone becomes less the higher the velocity of the stream and consequently the more frequent and violent the collisions with air: however it never disappears. The angle at which the water droplets diverge is characteristic of the system but for simple jets is only a few degrees ($< 10^\circ$ included angle).

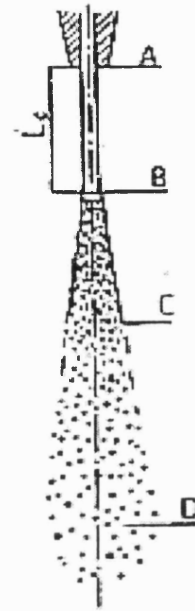


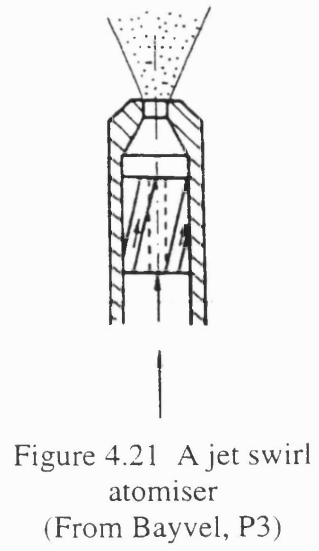
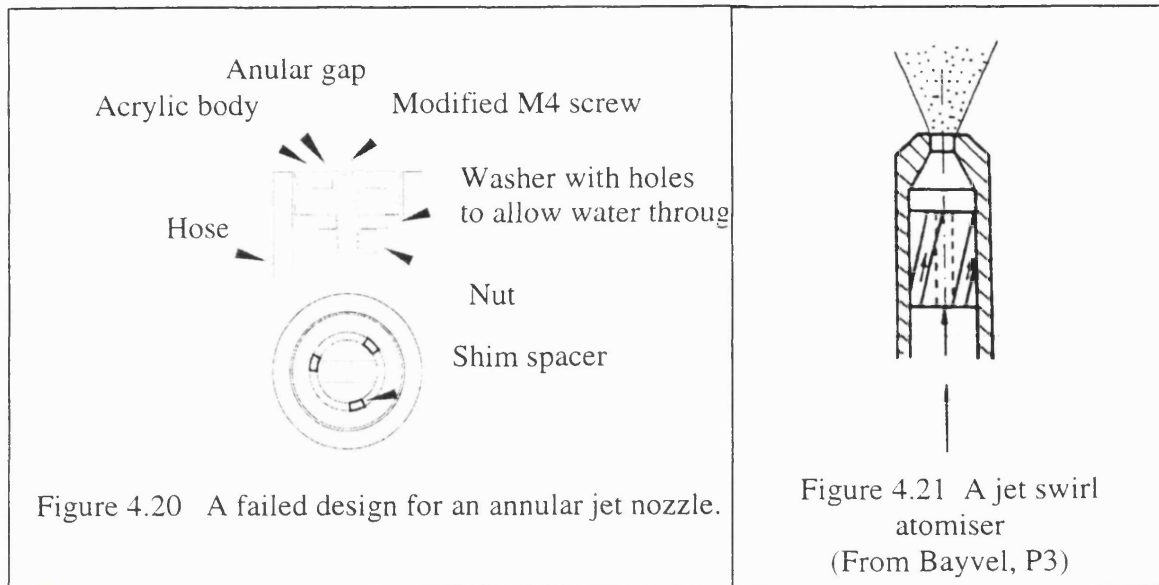
Figure 4.19 The break up of a jet spray (from Bayvel P.41)

At lower velocities the break up of the stream is not caused by aerodynamic forces but by waves that build up within the stream. This results in a much longer compact zone and a narrower dispersion angle.

The simplest modification that could be made to the nozzle design was to taper the holes so that the water emerged from a diverging cone. Tests were made with various tapers up to 6° included angle but all the results were unsuited to our application. The jet of water emerging from the cone appeared similar to one from a cylindrical nozzle except that aerodynamic forces became dominant at lower speeds, presumably because the air trapped between the taper and the water jet is highly turbulent. The transition from wave to aerodynamic atomising is sudden and extremely variable; sometimes the jet flips back and forth between one mode and the other. Even when the jet brakes up aerodynamically the compact zone is sufficiently long that the water jet might strike the tissues before it has atomised.

A number of other atomisers were considered and rejected. Piezzo electric oscillators and other mechanical devices were ruled out as being too complex to incorporate in the space available. Ceiling sprinklers for fire protection have the jet strike a plate, which is simple and effective but creates a very wide angle of dispersion so that forward thrust of the jet is

lost. Figure 4.20 shows an attempts to build a 5 mm diameter nozzle with an extremely small annular gap (nominally 0.1 mm) which failed to produce an even cone of water, was prone to clogging and was not robust.



In a swirl atomiser the stream of water enters the jet nozzle in such a way that it spins around the axis of the nozzle, then as it leaves the nozzle centrifugal force causes the jet to atomise and fan out. Figure 4.21 shows one variant on the design which is called a ‘jet swirl atomiser’. Hesche et al²² describe a method for making extremely small swirl atomisers using micro-machining and etching methods that could in principle be used for our application; however there would be very considerable practical problems to overcome and the pressure drop across the head would probably be considerable.

4.6.1 The impinging jet atomiser

In view of these problems it was a relief to find that a simple but rarely used style of atomiser worked well for the present application. Atomisers with impinging jets of liquid have been used in rocket engines where rapid and intense mixing of the fuel components is required and Figure 4.22

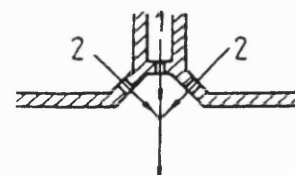


Figure 4.22 Atomiser with colliding jets. (Bayvel P.161)

shows a configuration where one part of fuel is mixed with two parts of oxidiser.

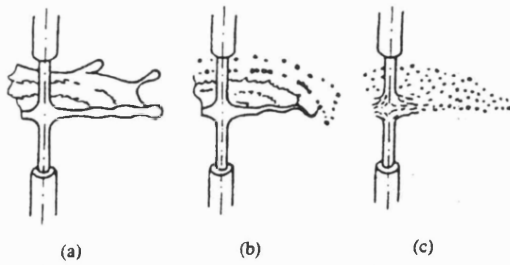


Figure 4.23 Streams colliding at (a) several m/s, (b) 20 m/s and (c) very high speed. (Bayvel P.57)

When two streams of water collide with each other from directly opposite directions they initially form a smooth sheet of water that fans out as a disc, however the turbulence caused by the streams mixing together causes the disc to vibrate and break up into droplets, as can be seen in Figure 4.23. At very high velocities, such as are encountered in the

jet propelled endoscope, the turbulence generated at the collision is so intense that the sheet disintegrates before waves have had time to develop.

When the two jets of water do not come from directly opposite each other but meet at an angle the sheet formed is elliptical rather than circular and as the angle between the jets becomes more acute so the ellipse becomes more skewed away from the nozzles (Figure 4.24). So, although the spray is mainly in the direction of the jets, it can be seen with the test nozzles that have been made that a small proportion of the atomised spray comes back towards the nozzles.

Once the sheet brakes up the spray spreads out in three dimensions. The angle of dispersion in the dimension normal to the sheet is very roughly ten to twenty degrees and appeared to be rather variable. A possible explanation of this variability was that small errors in drilling the 0.5 mm diameter holes meant that the emerging water jets did not collide exactly on axis.

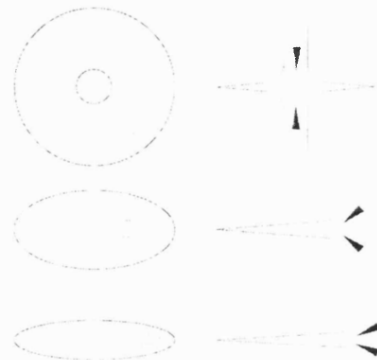




Figure 4.24 Sheets produced by jets impinging at various angles.

In practice the very high velocities involved meant that the streams atomised almost instantaneously into a fine spray, almost a mist, and it was impossible with the equipment available to judge accurately the spatial distribution of the plume. It was possible to form

a rough impression of the distribution by moving a rubber membrane around and seeing how it deformed; the drum described above was reconfigured as a tambourine to achieve this. So far as could be told the shape of the spray was as anticipated.

The subsequent collision of the water jets does not influence the water as it travels through the nozzle and so does not effect the magnitude of the thrust generated as the water accelerates in the nozzle. In other words, the water inside the nozzle does not know that it will subsequently be involved in a collision. All that is lost in changing the jet propulsion head on an endoscope from, say, eight independent nozzles to four pairs of impinging nozzles is that the nozzles no longer point straight back but are inclined at an angle of about 20°. Since the cosine of 20° is 0.94 this loss is not large.

The conclusion that the thrust produced while generating a fine spray would be only 6% less than that from a 'powerful' jet seemed rather surprising and the opposite of what one would initially expect. An experiment with the apparatus described in Figure 4.5 was performed, the results are presented in table 4.4. All the holes were drilled with a 0.52 mm drill bit, the included angle between the convergent nozzles was 40° and the pressure at the piston pump was kept to a nominal 10 bar by operating the pump at full speed and adjusting the needle valve that allows water to be bled off.

No. of holes	Flow (ml/s)	Thrust (N)	Thrust per hole (N)	Style of nozzle
1	6.3	0.28	0.28	Parallel – 'hard' jet 
2	14	0.52	0.26	
3	17.3*	0.78	0.29	
4	26	1.06	0.26	
1	7.2	0.24	0.24	Convergent – finely atomised Included angle between jets = 40° 
2	15	0.45	0.22	
3	21.3	0.66	0.23	
4	26	0.86	0.22	

* Suspected error in measurement

Table 4.4 The thrust developed by impinging and non-impinging jets.
(Pressure = 10 bar, all holes of 0.52 mm diameter)

It can be seen that the ratio of the thrust from the convergent jets to the parallel jets is about 0.85 rather than the 0.94 anticipated and that this is fairly consistent regardless of

the number of holes in the nozzle. Curiously this discrepancy is apparent even for the situation where there is only one hole and no colliding water jets, so it is not a consequence of the atomising process. At the time these experiments were performed the author put the relative underperformance of the angled nozzles down to differences in the effective areas of the holes caused by different machining processes or by the different entry and exit geometries of the holes. However returning to the data now it is clear that this explanation was wrong because the flow rates are higher for the angled nozzles and a larger flow at the same pressure should result in a larger force regardless of area. Reference to Table 4.1 shows a mean thrust 1.14 N/mm^2 (ranging from 1.03 to 1.26 N/mm^2) which for a 0.52 mm diameter hole implies a thrust of 0.24 N which is exactly the same as was measured with the angled nozzle.

In hind sight, this discrepancy between the observed thrusts and the predicted thrusts should have been investigated more fully but at the time the practical problems associated with building atomisers into a prototype jet propelled endoscope seemed more pressing. In particular there was concern that if one of the orifices became clogged then its partner would spray outwards unatomised

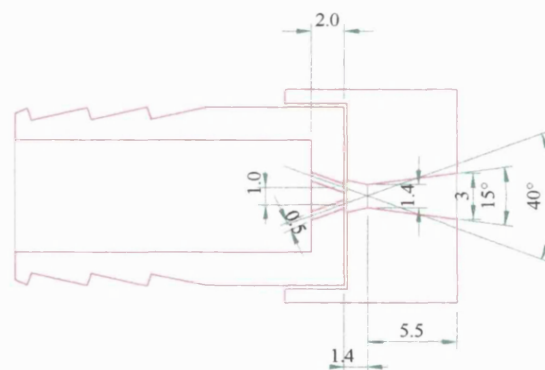


Figure 4.25 Drawing of nozzle with after-nozzle attached.

and could produce damage to the colon wall. To avoid this it was decided to add a second stage to the nozzle with a tapered bore, see Figure 4.25, so that neither jet could strike the colon wall without first bouncing off the inside of the 'after-nozzle' and at least forming a conical sheet.

The test piece that had been used for the results presented in Table 4.4 was mounted into the rig again and the thrust measured with and without the after-nozzle. As before the gauge pressure at the pump was kept to 10 bar and without the after-nozzle a thrust of 0.44 N was measured while adding the second stage reduced the thrust slightly to 0.42 N .

The after nozzle produced a better defined dispersion angle with the spray more evenly distributed circumferentially, though the distribution was not even across the diameter with the spray being concentrated around the perimeter of the cone. Spraying against a latex rubber membrane showed that there was a high spot but that the situation was far better than when a nozzle producing two parallel jets was used. The drum illustrated in Figure 4.17 was used to test the effect of the atomised jet on porcine colon, which, as before, had been defrosted having been frozen directly after collection from a freshly culled pig. It was found that at 10 bar exposure for 10 seconds produced slight blistering and at 17 bar the blistering became worse but still no holes appeared. By comparison a 0.52 mm single jet nozzle at 10 bar rapidly produced a hole through the mucosa and serosa. These tests were repeated with saline rather than water but no significant difference was found.

4.7 Prototype jet propulsion head with atomising nozzles.

The prototype jet head illustrated in Figure 4.26 was built. It can be seen that it consists of eight nozzles arranged circumferentially around the shaft of a paediatric endoscope. Each nozzle is a miniature version of the “Nozzle with after-nozzle attached” (Figure 9) with two 0.5 mm impinging jets being contained within a tapered cylinder. Considering the plan view as a clock face, the nozzles are at 1, 2, 4, 5, 7, 8, 10 and 11 o’clock with inlet tubes at 12 and 6 o’clock. Space has been left at 3 and 9 o’clock for screw holes to be added for a clamping arrangement such as that illustrated in Figure 4.12 to be used to attach the head to the endoscope. However, in view of the complexity of building the atomising head, it was decided to use hot melt adhesive to hold it in place.

4.7.1 Results using the head with atomising nozzles.

The head produced a thrust of 2.2 N when the flow rate was 83 ml/sec and the water pressure at the pump was 17 bar. Referring back to the thrust produced by the “nozzle with after-nozzle attached” this suggests that the pressure drop across the nozzles was 6.5 bar. This flow felt ‘soft’ when it was directed onto one’s hand and when tested in a length of excised pig colon it produced no visible damage. The test was to pass the endoscope, with the jets on continuously, slowly back and forth, five times, through a 30 cm length of colon. The colon was then turned inside out and a visual inspection showed no damage.

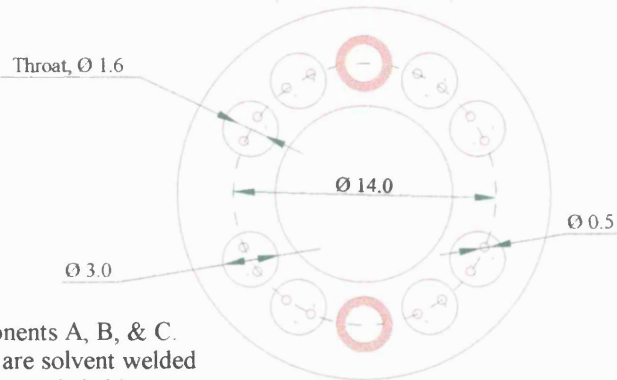
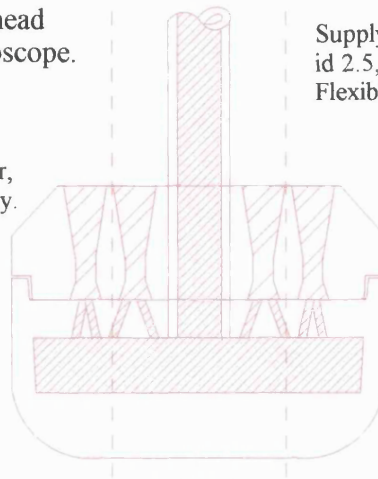
The head was attached to the Pentax FG29X gastroscope and tests were carried out with the model using an ‘S’ shaped piece of excised pig colon (described in Appendix 1 section A3), to see whether this head gave a significant benefit. Tests were carried out on two occasions, using different pieces of defrosted colon, taken from the same pig. On each occasion, the endoscope was first pushed around the colon without using the water spray and then twice more passed around the colon with intermittent bursts of water spray. The water jets were used at points where it was necessary to push relatively hard to advance the endoscope.

Unfortunately, both the pieces were relatively easy to endoscope using conventional techniques, probably because the colon was of relatively small diameter (30-40 mm when inflated). Never the less, it was clear that on every test the water jets behaved as anticipated and helped pull the endoscope forward. It could be seen that when the jets were used, there was less stretching of the Nylon stockings that were used to retain the colons and simulate mesenteries. This suggests that using the jets would make colonoscopy less painful.

Acrylic atomiser head
to fit paediatric endoscope.
14 Jan 1998

Supply tube
id 2.5, od 3.2
Flexible Nylon 11

Dense hatch = water,
Coarse hatch = spray.



Components A, B, & C.
A & B are solvent welded
together. C is held on
with hot melt adhesive.

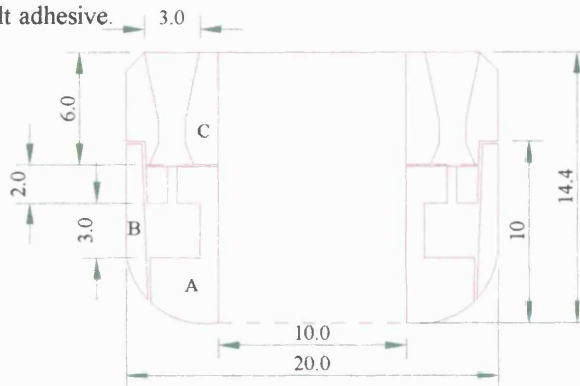


Figure 4.26 Prototype jet propulsion head with atomising nozzles.

4.8 Conclusion

Water jet propulsion is a practical method of delivering propulsion at the tip of a colonoscope but more realistic testing is required to determine whether the force generated is large enough to be useful. If a low force of, say, one Newton proves helpful then this approach would be very attractive. However the tests so far suggest that a larger force would be desirable. Increasing the force requires increasing the mass flow rate or increasing the velocity of the water through the nozzles. Within reason, the maximum volumetric flow rate is a matter of clinical convenience rather than safety and a more realistic model would allow clinicians to judge the maximum acceptable volume of water that can be delivered in one pulse. Increasing the force by increasing the water's velocity raises safety issues that are much harder to assess and require more experimentation.

In view of these difficulties it was decided to start work on an alternative approach and maybe return to jet propulsion when more realistic models are available. The approach chosen was similar to the "suction crawling" described above in Chapter 2, the literature review (although, at the time, we did not know of its use by another group).

5 Using a 'suction crawler' to pull the endoscope.

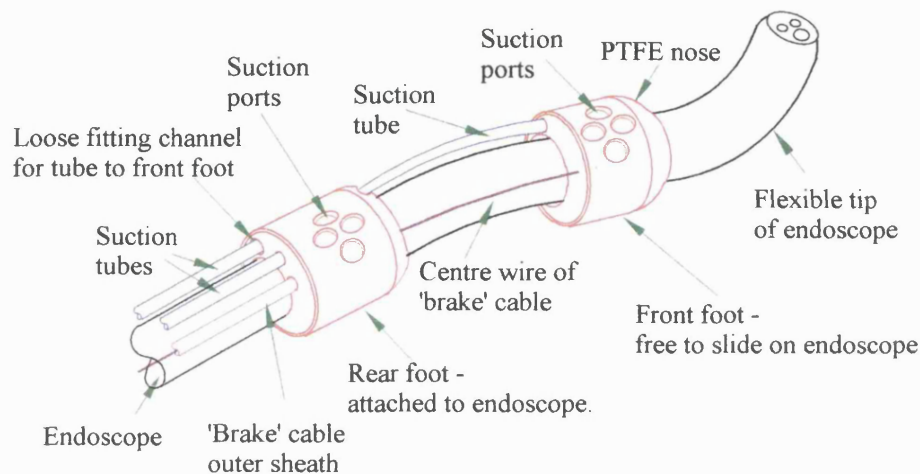


Figure 5.1 A suction crawler mounted onto an endoscope

5.1 Introduction

It will be remembered from the literature review earlier in this thesis that there have been a number of efforts to make 'earth worms' that could crawl along the colon. What these systems all have in common is that they use one or more expandable balloons to anchor themselves in the colon while some mechanism advances another balloon, or balloons, which can then in turn be expanded to act as an anchor while the first set of balloons are contracted and moved forward. It has been reported that in vivo tests show that this "principle is suitable for propelling the micro-robot in the colon efficiently without significant damage to the colon wall"¹, but there must be concern that any earthworm system gets its grip by inflating a balloon that presses outwards against the walls and relatively small pressures can burst the colon. In 1931 Burt² inflated the colons from a series of 18 cadavers and found that the pressure required to tear the serosa ranged from 43 kPa (325 mmHg) to only 5.4 kPa (41 mmHg) with a mean value of 18 kPa (137 mmHg). Several references to insufflation during colonoscopy can be found in Chapter 4 section 1.5.1 .

The problems associated with inflating cuffs to press against the wall can be avoided by using suckers instead of balloons to grip the wall. The idea for using suction feet to walk along the colon was suggested by Dr Feng Gong, who had been working with Dr Swain and Dr Mills developing an endoscopic sewing machine that used suction to draw tissue into a small cavity where a stitch could be passed through it³. In his PhD thesis⁴, Feng Gong proposed that it might be interesting to develop a propulsion method that consisted of two heads containing suction chambers separated by a bellows; - a caterpillar rather than a worm. (See Figure 5.2)

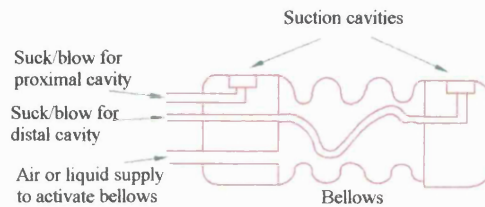


Figure 5.2 Schematic drawing of a suction crawler using bellows.

It was decided to build a device using suction heads and bellows as part of this PhD project. It was also decided to develop a system that could be attached to an existing endoscope so that the refined technology incorporated in a modern flexible endoscope would not have to be reinvented. Figure 5.1 at the head of this chapter is a schematic drawing of a suction crawler attached to an endoscope.

An initial search of the literature revealed nothing directly relevant and it was only after building some prototypes that we learned from a review article⁵ that an Italian group, whose work on earthworm systems we were already familiar with, had also been working on suction crawlers and had already published⁶ and applied for a patent which was subsequently granted⁷. The striking similarity between their device and the one we had built will be illustrated later in this chapter. (Incidentally, it will be seen in the Appendix describing the models built for this project that the same article also described a model that was similar to but predated our work!)

5.2 The principles underlying the design of the suction system

There are three components to the suction system; the vacuum pump, the vacuum tubing and the suction heads themselves. These three elements will now be discussed in turn.

During this discussion it should be remembered that suction cups are usually used to apply a force normal to the load but that the proposed crawler uses them to gain a foothold and pull the endoscope forwards parallel to the colon wall. When a suction cup is attached to the flat top of a load, then the maximum force that can be exerted is simply the area of the cup multiplied by the vacuum (for simplicity the term “vacuum” will be used throughout this chapter as shorthand for “the pressure difference between the inside of the cup and the surrounding atmosphere”). However, when the suction cup is being used to provide a force parallel to the surface it is sucking, then it will tend to slip along that surface and the factors affecting how well it grips must be considered. It is possible to paraphrase Newton’s law of friction and say that the force exerted parallel to a surface equals the force applied normal to that surface multiplied by a factor that includes the frictional properties of the material as well as the geometry of the shapes moving past each other.

5.2.1 First element; - the vacuum pump

The requirements for the pump are that it should pump sufficiently fast that the rate at which the pressure in the chamber drops or a leak is counteracted, is dominated by restrictions to the flow of air through the tubing rather than by the pump. The pump must also be able to pump down to a low pressure (say 2 kPa) which rules out normal single stage centrifugal pumps which are commonly used for commercial suction cups handling paper or card. “High vacuum” is not required as it is the pressure difference between the inside and outside of the chamber that determines the force, not the absolute pressure; - an improvement from 2 kPa to 0.02 kPa only adds about 2% to the force, taking atmospheric pressure as 100 kPa.

Most piston pumps used for laboratory vacuum chambers are sufficient for this purpose and an elderly Edwards Speedivac 1SP20 served for this project. A trap is also required since mucous and worse will be sucked off the colon wall.

5.2.2 Second element; - the vacuum tubing

Although the ultimate vacuum achieved in a sealed chamber depends only on the pump, the rate at which it is achieved in our application is limited by the small bore and length (typically 1.5 m) of the tubes connecting the pump to the suction heads.

The diameter of the tubes poses a dilemma; - on the one hand they should be as small as possible to maximise flexibility and, for the device attached to an endoscope, to minimise the overall diameter of the endoscope and the tubes running beside it. On the other hand they should be as large as possible to maximise the flow rate of the air through them and to reduce the risk of clogging. Although it is not practical to analyse all these aspects rigorously, it is possible to consider them in turn and elucidate the factors which determine the ultimate choice. The next few paragraphs will attempt to do this.

The arguments in favour of small tubes are to do with size and flexibility. When the suction heads are mounted onto an existing endoscope then the diameter of the rear head must be sufficient to clear the shaft of the endoscope and to allow the suction tube to pass through it. Whilst it is possible to insert quite large objects into the colon, it is obviously desirable to keep the suction heads as slim as possible.

The factors influencing flexibility can be elucidated by treating the tube as a circular hollow beam and applying classical beam bending theory. However, elementary bending theory has to be applied with caution to plastic tubes since it assumes an elastic material (i.e. strain is proportional to stress) and that the deflections are small so that the cross section remains constant and the moment of the load about the fulcrum is unchanged.

Consider a section of tube that is mounted as illustrated in Figure 5.3. The force required to bend a given length through a particular angle is⁸;

$$F = \theta/L^2 \cdot 2EI$$

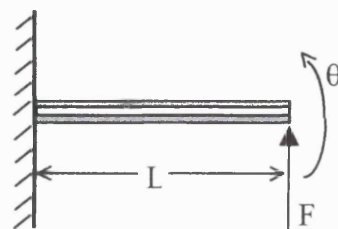


Figure 5.3 Beam bending

where F = Force applied

θ = angle bent

L = length of section being bent

E = Young's modulus for the material (Nylons are in the range 2- 4 GPa)

I = second moment of area which, for a circular tube, is given by;

$$I = (d_1^4 - d_2^4) \cdot \pi/64$$

Where d_1 = outside diameter

d_2 = inside diameter

The striking feature of this equation is the dependence on the fourth power of the diameter, so plainly a thin wall and a small diameter are highly desirable. For example, the largest Nylon tube in the Portex medical range has a bore of 2.44 mm and an O.D. of 3.24 mm which gives a second moment of area of $3.7 \times 10^{-12} \text{ m}^4$, whilst a tube from the middle of their range has dimensions I.D. = 1.5 and O.D. = 2.1 mm, giving it a second moment of area of $0.7 \times 10^{-12} \text{ m}^4$. Thus a reduction of about a third in the bore gives about a five fold increase in flexibility.

The above equation shows that the stiffness of the tube also depends on the Young's modulus of the material. The requirement is that the material should be flexible yet stiff enough not to collapse under vacuum or kink even when it is bent to a tight radius. Also, the material must be bio-compatible. The flexible Nylon tubing that had been found for the water jet propelled endoscope met these requirements well enough, was inexpensive and also had good frictional properties when sliding over wet tissues. However, it may be that a wire reinforced PVC or silicone rubber vacuum tube would have given greater flexibility for the same dimensions.

So much for the arguments in favour of using small diameter tubes, the benefit of larger diameters will now be discussed. These are that larger tubes are less likely to become clogged and that they allow a faster rate of air flow.

Clogging is mainly prevented by frequently flushing the tube with water and by including a neck or sieve where the tube joins the vacuum chamber so that no large particles can enter the tube. Nevertheless fine tubes tend to clog, particularly where there are tight bends. The problem becomes worse the smaller the bore because the force shifting the blockage depends on the square of the radius (pressure x area) while the

adhesive force holding it in place depends on the area in contact with the wall which is proportional to the radius of the tube (length x perimeter).

The flow rate does not only affect the rate at which the ‘suck – advance – suck’ cycle can be repeated, it also affects the likelihood of leaks occurring and causing the vacuum to be lost. Up until now, the chambers have been discussed as though they had little lids that were closed before the suction was turned on. This is not the case and it is the suction itself which must pull the tissue in to seal the chambers. Drawing the tissues into the chambers can easily be achieved by pumping all the existing air out of the colon so that it collapses onto the suction head. However it is extremely difficult to move an endoscope through a colon that is sucked down tightly onto it and so it is necessary to, at least partially, reflate the colon before advancing the device. Once there is air inside the colon leaks may occur and “poison” the vacuum in the chambers unless the flow rate out of the chambers along the suction tubes is faster than the leakage rate into the chamber.

The size of the leaks is unknown, but it is possible to describe the rate at which gas can be sucked out of the chambers along the tubes. The flow of gas in a long thin tube may be laminar or turbulent or a mixture of the two. When it is laminar, the resistance to flow comes from the viscosity of the medium and is described by Poiseuille’s law, whereas when it is turbulent much of the energy is absorbed in churning the air and the flow rate is less than would predicted for lamina flow. The Reynold’s number is the ratio of the dynamic to the viscous forces in a flow and a low Reynolds number, below about 2,000, indicates that the flow will be lamina while a high number suggests turbulence. However there is not a sharp transition between the two states and over a wide range of Reynold’s numbers some regions of the flow may be lamina while others are turbulent⁹, in particular, there is always turbulence where the gas enters the tube.

The Reynolds number is given by;

$$Re = 2 \rho.v.r/\eta$$

And, where the flow is laminar, the volume rate for a given pressure drop is given by Poiseuille’s law as;

$$Q = \Delta P . \pi r^4 / (8 \eta L)$$

Where Re = Reynold’s number

ρ = density, air at 20°C = 1.2 kg/m³
 v = mean velocity of air
 r = radius of tube
 η = dynamic viscosity, air at 20°C = 18 x 10⁻⁶ Pas (independent of pressure)
 Q = volume flow rate
 ΔP = pressure drop across the tube
 L = length of tube

Table 5.1 presents data for a 1.5 m long tube with the pressure drop assumed to be one atmosphere (≈ 100 kPa). The Reynold's numbers calculated using the measured flow rates are given and it can be seen that there is likely to be turbulence, which is confirmed by the discrepancy between the measured flow rates and the flow rates computed for a number of tube diameters assuming lamina flow.

Internal diameter of tube (mm)	1	1.5	2.2	3
Reynolds number	2,500	7,356	15,200	-
Computed <u>lamina</u> flow rate (l/s)	0.09	0.46	2.1	6.9
Measured flow rate (l/s)	0.03	0.13	0.4	-

Table 5.1 Computed and measured flow rates for various suction tube diameters

It can be seen that although the flow rates are considerably less than would be expected for purely lamina flow, they are still highly dependent on the radius. So once again there is a higher order dependence on the diameter but this time it is in the opposite direction, pushing the choice of tube towards a larger rather than a smaller bore.

What flow rate is required to pull the tissues down onto the suction chamber once a leak has started? No absolute answer can be given but considering some simple numerical examples is helpful. If the suction chamber has, for example, a 4 mm diameter then 0.03 l/s corresponds to a velocity of 2.4 m/s (about twice walking speed) which intuitively does not seem sufficient to grab a piece of tissue and drag it into the chamber although, of course, the area of a leak will probably be less than the area of the chamber. By contrast with the 2.2 mm tubing the flow velocity would, if it were not limited by other components in the system, be 32 m/s (115 km/hr) which intuitively sounds more than sufficient.

This discussion of the factors influencing the choice of suction tube diameter does not lead to a numerical expression that can be optimised, but it does appear that a bore of about two millimetres gives a reasonable flowrate while being flexible and compact and, so long as it is frequently flushed, not liable to clogging. Having outlined the factors affecting the choice of pump and suction tubing it remains to discuss the issues surrounding the design of the suction chambers.

5.2.3 Third element; - the vacuum chambers

The factors affecting the strength with which a suction head grips the colon wall and, above all, the reliability with which it establishes and maintains suction are complex and the discussion in this section will therefore be impressionistic rather than rigorous.

The overall dimensions of the suction heads are more or less given by the dimensions of the colon, rectum and anus and, where the device is being attached to a colonoscope, the diameter of the colonoscope. However there is leeway in the design of the suction chambers that are built into the

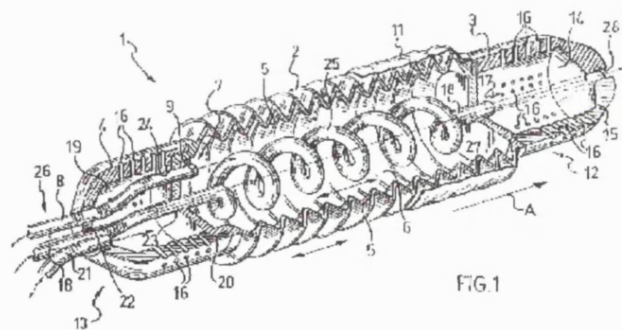


Figure 5.4 The suction crawler from Dario et al. Reference 7

heads. A fundamental design question is whether to use a few large chambers or many small ones. A possible advantage of having many small holes is that, for the same total area, the aggregate perimeter of the holes is increased and it is the wrapping of the tissues around the edges of the chambers that provide the grip. Figure 5.4 is taken from Dario et al's patent⁷ and it can be seen that they chose to use many small holes (item 16 on the drawing) to form suction cavities.

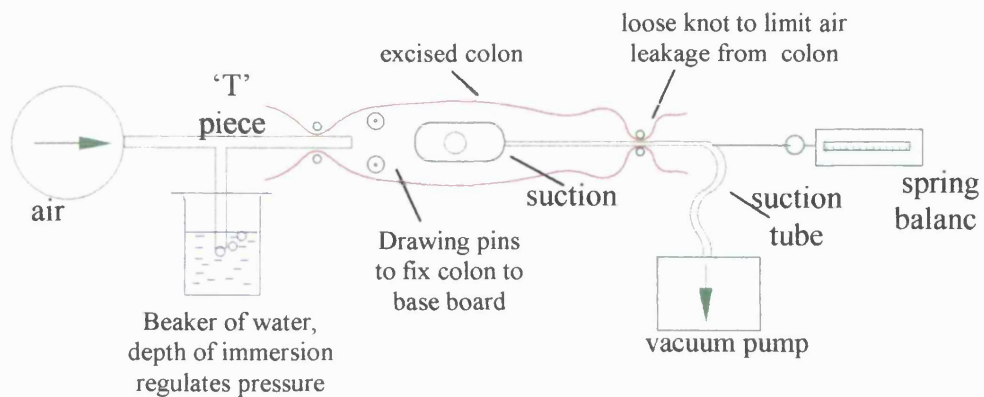


Figure 5.5 Equipment to measure the strength of attachment achieved by various designs of suction heads

It was decided to investigate this experimentally and the apparatus illustrated in Figure 5.5 was set up to compare the five different suction chamber hole designs included in the illustration. Table 5.2 presents the data found using these five designs on the same length of colon which was periodically wetted on its outside. Looking at the results for the heads with parallel sided holes it can be seen that they do not confirm that there is any advantage to using many small holes, on the contrary the force required to pull the head back along the colon is proportional to the total area of the holes and independent of whether the individual holes have a diameter of 1.1 mm or 4 mm. Furthermore, on the line below it can be seen that when the colon was inflated it peeled off small suction cavities even when inflated only weakly.

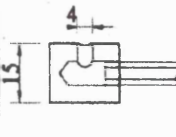
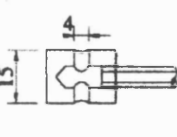
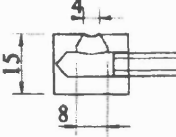
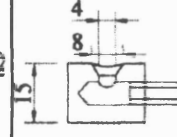
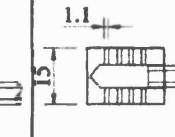
					
	Single 4 mm hole	Two 4 mm holes	Hole tapered inwards	Hole tapered outwards	52 x 1.1 mm holes
Total hole area- mm ²	12.6	25.1	12.6	12.6	49.4
Pull back force (N) 3 readings	1.5, 1.7 and 1.3	3.0, 3.2, and 3.0	2.0, 3.0 and 2.5	1.0, 1.2 and 1.3	6.5, 6.0 and 6.0
Peel off pressure (kPa)	>2.8	3.0	>3.3	2.5	0.2

Table 5.2 Results achieved with the apparatus illustrated in Figure 5.4

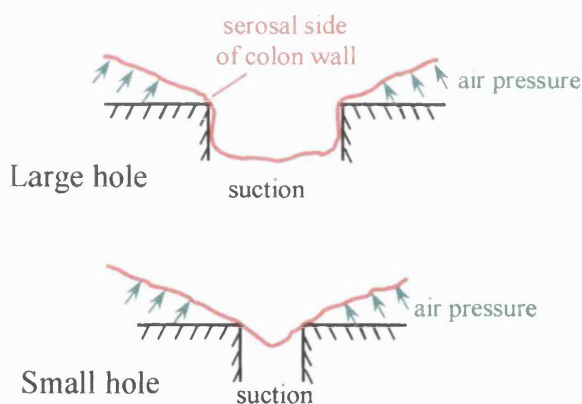


Figure 5.6 The extent to which colon is sucked down into a hole affects the ease with which it peels off the hole.

The tendency to lose suction when the colon was insufflated confirmed what had been observed during experiments using a many holed prototype in a model. A possible explanation for this is illustrated in Figure 5.6, which shows colon being sucked down into two holes, one large and one small. The arrows indicate the pressure of

insufflation tending to lift the tissues up from the hole and create a leak that will poison the vacuum. It can be seen that not only is the force pulling the colon down larger in the large hole, but also the colon conforms to the walls of the large hole and the insufflation pressure has to pull the entire slug of tissue up the hole before the seal is broken. By contrast with the small hole only one side has to be lifted to allow air into the chamber.

Returning to Table 5.2, it can be seen that the shape of the hole affects the pull and the peel in ways that are unsurprising. If the hole is tapered such that the tissue is being

pulled into an expanding chamber (column 4) it grips the tissue more strongly than when the taper runs the other way (column 5). When it came to building prototype suction crawling devices, it was impractical to make the heads with holes tapering away from the inside of the device but it will be seen in a later section that the same effect was achieved for the devices that fit over an endoscope, by making the body of the chamber much larger than the openings into it .

The importance of the size and shape of the holes probably accounts for the failure of an early prototype head that used a single 8 mm diameter hole as a suction chamber. So that tissue would not be drawn into the chamber, the hole was covered with a fine stainless steel mesh (200 lines per inch) that had been made for screen printing. This design was abandoned after it was found that, even when it was fully evacuated, the mesh slid easily over the surface of the tissues requiring a force of only about 1 N to drag it along.

There were a number of design ideas that might have helped but were not investigated because they were deemed to add too much difficulty to constructing the devices. For example, it is possible that the suction cavities would grip the colon more strongly if the holes were made some shape other than circular. One can imagine that a triangular shape oriented so that its apex pointed towards the front of the endoscope might be effective at preventing the head from slipping over the tissues. However the practical difficulties of making holes other than circular ruled out such designs. Similarly, it may be that a better grip might have been achieved by making the suction heads out of a material that had a higher coefficient of friction but as before, it was felt that PVC with an unpolished finish offered a reasonably ‘non-slip’ surface while being easy to glue and to machine into thin sections.

One idea that did help was to orient the suction holes as illustrated in Figure 5.7 so that the tissues become tightly wrapped around the back of the suction head as it is pulled back. Working with a length of uninflated colon it was

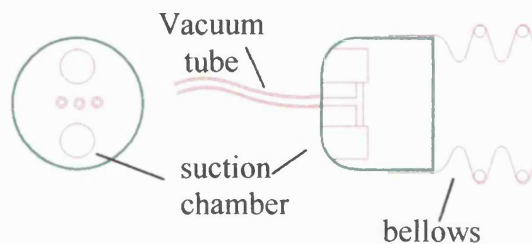


Figure 5.7 Rear facing suction ports

found that a mean force of 5.1 N ($n = 10$, SEM = 0.3 N) was required to pull the head backwards, while a similar head with radial holes slipped when the mean load was 3.9 N

($n = 3$, SEM = 0.3 N). It will be seen in the next section that the bellows driven suction crawlers were made with the rear suction ports facing backwards and that these worked well in model colons. There were problems with the tissues peeling off the suction chambers if the edge of the chamber was made too close (say, less than 3 mm) to the suction tubes. Since these problems were presumably caused by the tissues having to bend too sharply, they might be more pronounced with living tissue.

Having discussed some of the issues relating to the design of suction crawlers, the work associated with building prototypes will be described next. Suction crawlers using bellows will be dealt with first before a separate section is devoted to devices using a Bowden cable (i.e. a bicycle break cable) to move the suction heads relative to each other.

5.3 Design and construction of prototypes - Suction crawlers using bellows.

The ease with which a section of tissue could be gripped and the strength with which it could be held suggested that it was practicable to build a device that could crawl along the colon using suckers to anchor itself. This section describes the suction crawlers that were built using concertina bellows to move the suction heads.

A major concern was that the ratio of the expanded to the contracted length of the bellow should be as great as possible so that the colon could not prevent any forward progress by stretching and contracting in step with the bellows, as illustrated in Figure 5.8. Unfortunately, the requirement for a large dynamic range at an appropriate diameter could not be met from stock by any of the commercial concertina bellows manufacturers that were

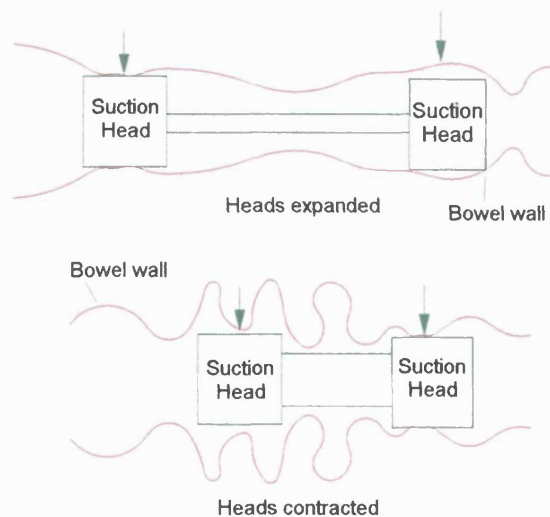


Figure 5.8 The bowel wall concertinas as much as the bellows so that no progress is made

contacted. One company was happy to supply so long as their tooling costs were met, but these were too much for the budget available. It was therefore decided to make bellows using latex rubber, which is convenient for making prototypes but suffers from the serious shortcoming that it discolours after it has been wet and, unless it is dried rigorously after use, loses its mechanical strength while being stored between experiments. It was often necessary to use fresh patches of latex rubber to repair punctures after the bellows had been stored for a number of days.

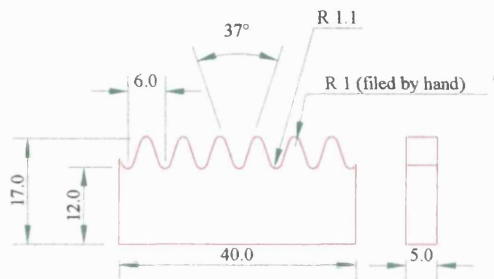


Figure 5.9 The steel tool used to make the form for the bellows

The method for making the bellows was as follows. A cutting tool was first milled out of plate steel as illustrated in Figure 5.9, and this tool was then used on a lathe to make the form of the bellows out of a length of PVC rod. Once the form had been turned it was coated with a solution of pre-vulcanised natural rubber latex

(Alec Tiranti Ltd, London) before being rotated in the lathe again to spin off excess rubber. It was then baked for about ten minutes at 75°C to produce a cured layer about 0.1 mm thick. After four layers had been applied the coating was tough enough to be dusted with talcum powder and rolled back on itself off the PVC form. The rubber did not adhere to the form and no mould release was necessary.

The rubber could now be unrolled and the bellows appeared complete. However, it was still necessary to add reinforcing rings as otherwise when suction was applied and the contraction was resisted by a load, the bellows collapsed radially rather than contracting longitudinally. The reinforcing rings were turned from aluminium and care had to be taken to radius all edges as otherwise they chafed at the rubber and rapidly produced leaks. Figure 5.10 shows the drawing for a rubber bellows with aluminium reinforcing rings.

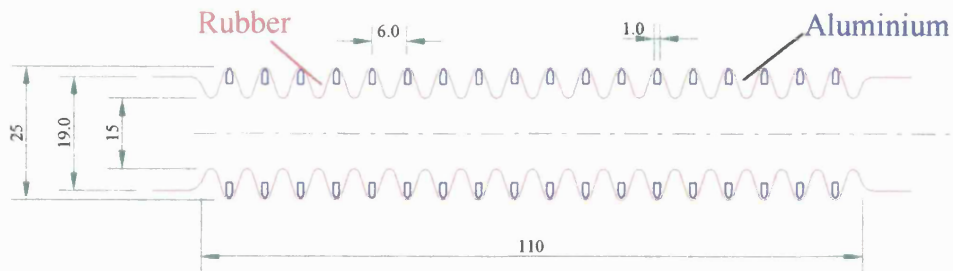


Figure 5.10 The completed bellows for a suction crawler.

The heads and tails for the three bellows driven suction crawlers that were built were broadly similar and only those made for the smallest of the three crawlers will be described in detail. Figure 5.11 is a photo of the three crawlers and Figure 5.12 is the drawing for the smallest crawler. As can be seen the end pieces are made from polished acrylic, except that a PTFE cap is fitted to the largest crawler's head. This cap was made because it could be seen that pushing the acrylic head around bends in the excised colon was stretching the tissues considerably and it was hoped that the PTFE would slide more freely. In the event it did slide more freely, but it also became apparent that the problem was caused by the tissues becoming too dry and that if the colon was kept well wetted the acrylic did not stick so much. *In-vivo* colon appears wet when viewed through an endoscope, so there is probably no need for the PTFE cap.

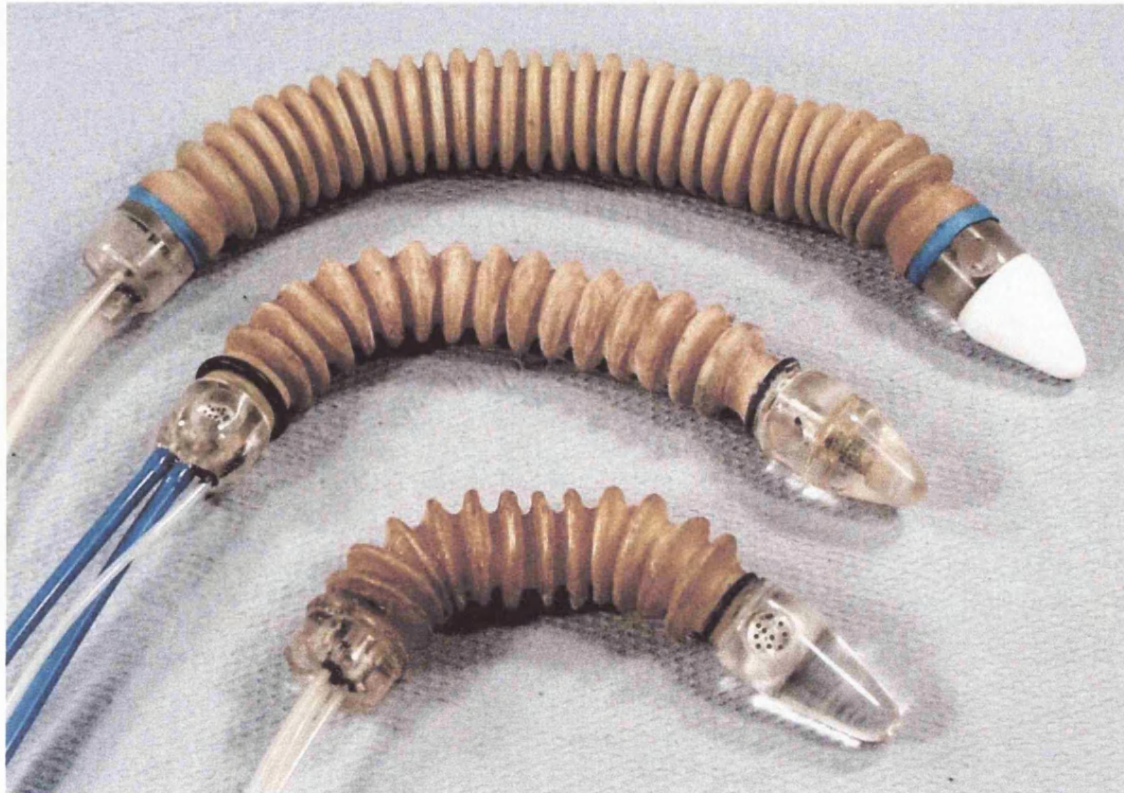


Figure 5.11 Three suction crawlers using bellows. Chronologically the smallest was made first, then the mid size and finally the largest. It can be seen that the technique for rubber casting improved with time. The two smaller bellows are 20 mm O.D. and 10 mm I.D. The largest bellows is 25 mm O.D. and 15 mm I.D.

It can be seen that small aluminium sieves have been glued into the bases of the chambers of the small and middle sized crawlers. Initially they were made without sieves. However it was found that the narrow tubes tended to become clogged and so it was decided to add crude screens made by drilling 1mm diameter holes in aluminium disks. This was particularly true for the nose piece because the coiled suction tube joining the nose and tail sections was the “weakest link in the chain” so far as clogging was concerned. The largest crawler has a single narrow neck leading to the suction chamber to prevent objects clogging the tubes. The advantage of a single hole is that the water flush has to flow through it rather than having a choice of which of many holes to flow through.

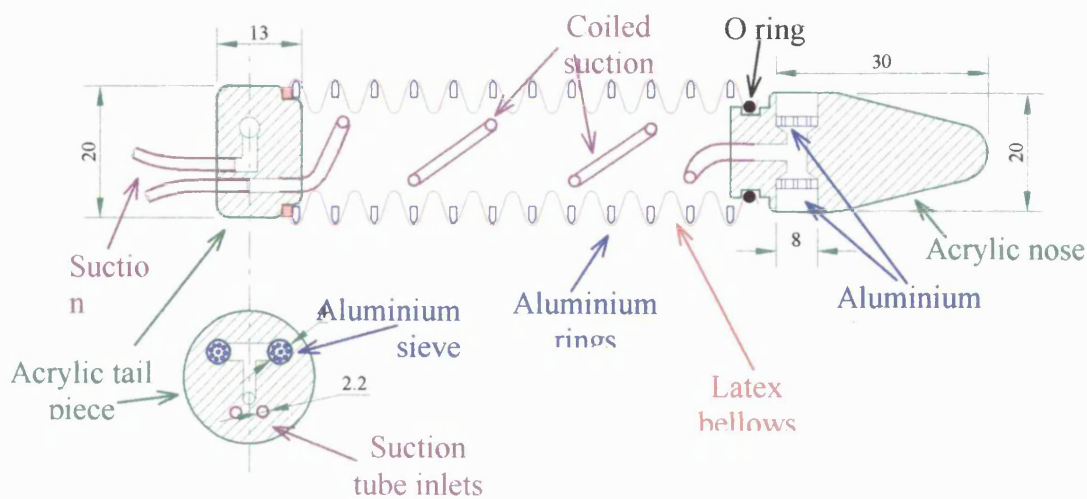


Figure 5.12 Drawing of the shortest bellows driven suction crawler

The tube taking the suction to the front head turned out to be remarkably problematic. The first prototype suction crawler used a length of silicon rubber tubing (I.D. 1 mm and O.D. 2 mm) folded like the tubes of a trombone, but the small bore restricted the flow of air and tended to become clogged. To avoid this bottleneck it was decided to change to larger diameter tubes coiled as a helix, like the wire for a telephone hand piece. Despite using the Dial and Kompas trade directories it was not possible to find a commercial source for coiled helical tubes with the right dimensions, so it was decided to make them, initially using small bore nylon tube (I.D. 1.5 mm and O.D. 2.2 mm). The technique for making the helix was to slide a length of 1 mm diameter copper wire down the tube, then wind it tightly onto a 5 mm diameter mandrel and finally heat it to 150°C for half an hour. Once it had cooled down the wire could, with difficulty, be pulled out of the tube leaving a helical coil.

Although the helix looked neat, it did not function very well; one problem was that during the heating the bore of the tube pulled down onto the wire making it oval and significantly smaller. It proved impracticable to use a thicker wire because it was not possible to pull the thicker wire out of the tube at the end of the process. This problem became more serious later on when helices were made using flexible PVC and polyurethane tubes as, when they became oval, they tended to collapse under vacuum. In the end, however, a relatively large (I.D. 3 mm, O.D. 5 mm) polyurethane tube was found (supplier unknown) that was strong enough to be tightly wound so that it fitted

into the largest bellows without collapsing. Since this polyurethane tube was far more flexible than an equivalent bore Nylon tube, it was used for the largest crawler (I.D. 15 mm).

Another practical problem was to make the ends of the helices; ideally the tube would have spiralled out of the helix and ended up with straight lengths of tube running along the axis of the helix, but in practice this could not be achieved and the ends of the tubes were not coaxial, or even parallel. This tended to bend the bellows section of the crawler, which probably only mattered aesthetically. A more important failing was that the lead in at either end of the helix was about 10 mm and for the short crawler this significantly restricted the amount by which it could contract. To some extent this problem could be overcome by using short lengths of flexible silicon rubber tube to couple between the nylon tube and steel spigots that were inserted into the acrylic end pieces. The middle sized suction crawler used silicon rubber tubes (unstretched I.D. 2 mm and O.D. 4 mm) to connect between the end pieces and a helix made from 2.2 mm O.D. Nylon.

Attaching the bellows to the end pieces was not a problem since only a small excess pressure had to be withstood. The device illustrated in Figure 5.12 happened to use different methods at either end, with the nose being held by an O ring and the tail being glued on with rubber poured onto grooves cut in the acrylic. The glued joint was rather fragile and was sometimes broken during handling and in later models mechanical fasteners were used at both ends; it can be seen in the photo (Figure 5.11) that the largest crawler used two blue rubber bands to hold the bellows onto the end pieces.

Finally, mention should also be made of the air and water supplies for the tubes that connect to the tail of the crawler. A 60 ml syringe was used to pump air into and suck air out of the bellows so that they expanded or contracted. The insulflation was provide by a diaphragm pump (Aerostyle, London) and, as has already been mentioned, the suction came from an Edwards Speedivac 1SP20 single cylinder vacuum pump. The pump had a pressure gauge on its outlet and it was possible to see when the tissues had been drawn into the suction chambers by the sudden drop in pressure. A system of valves, which will be described in section 5.4, was built to facilitate flushing the tubes, controlling the insulflation and swapping over the suction and blowing between the front and back chambers.

5.3.1 Experiments and results from suction crawlers using bellows.

Preliminary tests were performed using lengths of excised colon as a model. The methods for making models using porcine colon are described in the appendix and will not be repeated here. Three different lengths of colon were used and, once problems with reliability and with setting up the model had been sorted out, there was a total of twelve runs using the two shorter crawlers.

The largest of the bellows crawlers did not work well because the extra friction, resulting from its greater length and diameter, caused the suction chambers on the front head to drag back along the colon wall rather than provide a firm anchor and this more than offset the advantage of extra length. Indeed, if the model was set up with the colon pulled tightly around the second corner of the 'S' bend, then the largest suction crawler would get stuck with the front head dragging back as far as it had been pushed forward.

The two smaller bellows systems worked well and on eleven of the twelve runs completed the full length of the colon model. If the colon was over inflated, there was a tendency for suction to be lost on the insides of bends where the tissues are bunched up.

The crawlers were better than expected at following the lumen without the benefit of steering, on only one occasion did the crawler lose its way and bury its head into the wall of the colon. This happened with the shortest crawler in an uninflated and particularly wide piece of colon (about 6 cm in diameter or about 9 cm wide when uninflated and lying flat). Excised colon is flaccid and it is likely that a living colon would have more shape to guide the crawler.

The reason for the bellows crawler following the lumen appeared to be that as the bellows expanded with the tissues attached to the rear suction ports, the colon was dragged back over the nose. By contrast when an endoscope was blindly pushed into the excised colon model, the tissues tended to bunch up in front of the tip and obscure the route through the lumen. To put it another way, the force resisting the advance of the crawler's nose is reacted against the wall of the colon a few centimetres behind the nose,

whereas the force resisting the advance of the tip of the colonoscope is reacted against the floor of the room by the endoscopists feet.

5.3.2 *Reasons for abandoning bellows*

Overcoming the difficulties associated with building bellows driven suction crawlers took time and effort, but the approach was abandoned almost as soon as successful prototypes had been made. The immediate reason for this was the discovery that the Italian group were working along remarkably similar lines, had started first and appeared well resourced. In itself the knowledge that others were working along similar lines would not have mattered very much but it reinforced concerns that already existed that this approach broke one of the tenets of the project; wherever possible a device should be an add-on to an existing colonoscope so that it will be practical to use clinically.

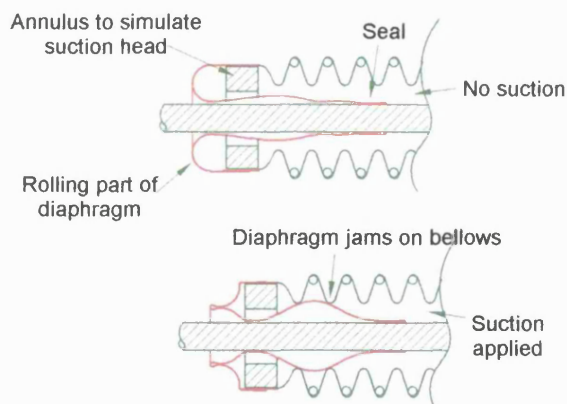


Figure 5.13 When suction is applied to the inside of the bellows it draws the rolling diaphragm onto the inside of the bellows and collapses the rolling area.

Both effects stop the 'rolling seal' from rolling.

The possibility of using bellows with an endoscope was considered but was rejected after some preliminary tests. An inherent disadvantage of having the endoscope pass along the midline of the bellows is that it reduces the cross sectional area over which the internal pressure can act to expand or contract the bellows.

A practical difficulty is that one

or other of the heads has to move back and forth along the shaft of the endoscope and this involves making a gas tight seal that can move with it; e.g. a sliding seal, a rolling seal, or a bellows seal. Sliding seals were rejected as being too stiff and too unreliable. A rolling seal was made and tested but when the air was evacuated from the bellows, it failed in an unexpected way as the rolling membrane collapsed onto itself and jammed against the bellows, as illustrated in Figure 5.13. As is often the case, this unexpected failure was obvious as soon as it happened.

The use of a second set of bellows, as illustrated in Figure 5.14, to make a pair of back-to-back bellows that could shunt a middle section containing suction chambers back and forth was an abject failure. The

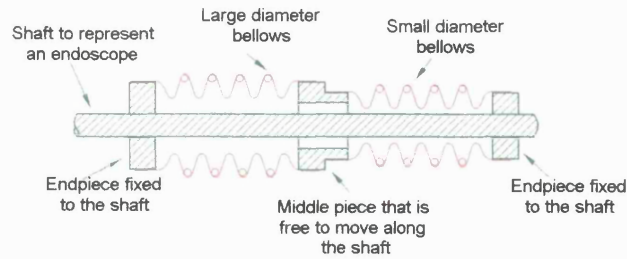


Figure 5.14 A pair of back-to-back bellows intended to move a middle section

principle was supposed to be that the larger diameter bellows would overpower the narrower bellows so that when the pressure within the bellows was raised, the narrow bellows would be forced to contract despite itself. The trouble was that when both bellows were trying to expand they did not push in a nice straight coaxial line but instead snaked about the rod that represented the shaft of an endoscope; in typographic terms the system was not “-O-” but rather “~O~”. This buckling of the bellows meant that they stuck on the side of the shaft and the pressure inflating them had to be increased, however the latex from which the bellows were made could only withstand very low pressures without blowing up like a balloon, at which point all the reinforcing rings fell out of place.

It might be that better design could have improved matters but the difficulties involved in trying to move a simple annulus back and forth along a rigid rod suggested that bellows driven systems would not work as an attachment to an endoscope where the shaft is flexible and where the moving section would have to drag a load and not just move itself. It was therefore decided to concentrate on suction crawlers that used Bowden cable to move the suction heads together and apart, and the next section describes the methods used to make cable driven suction crawlers.

Post script, September 1999.

Shortly before submitting the this thesis the author's attention was drawn to a French patent titled "Perfectionnements aux cathéters médicaux" that was filed in January 1961¹⁰. Figure 5.14ps reproduces three of the figures from this patent. It can be seen that Figure 2 anticipates the design described in Dario's 1997 patent⁷, while Figure 4 shows a version of the crawler which is suited for dragging a large tube into the colon. Admittedly, a lavage tube is shown, rather than an endoscope, but, given the date, this is not surprising. Figure 5 shows something similar to a Bowden cable, item 27 is a sheath from which emerges a wire (26) which passes over a barrel (22') and is anchored at 23'. Combining the Bowden cable from Figure 5 with the suction chambers from Figure 4 yields a device similar, in principle, to those described in the next section of this chapter.

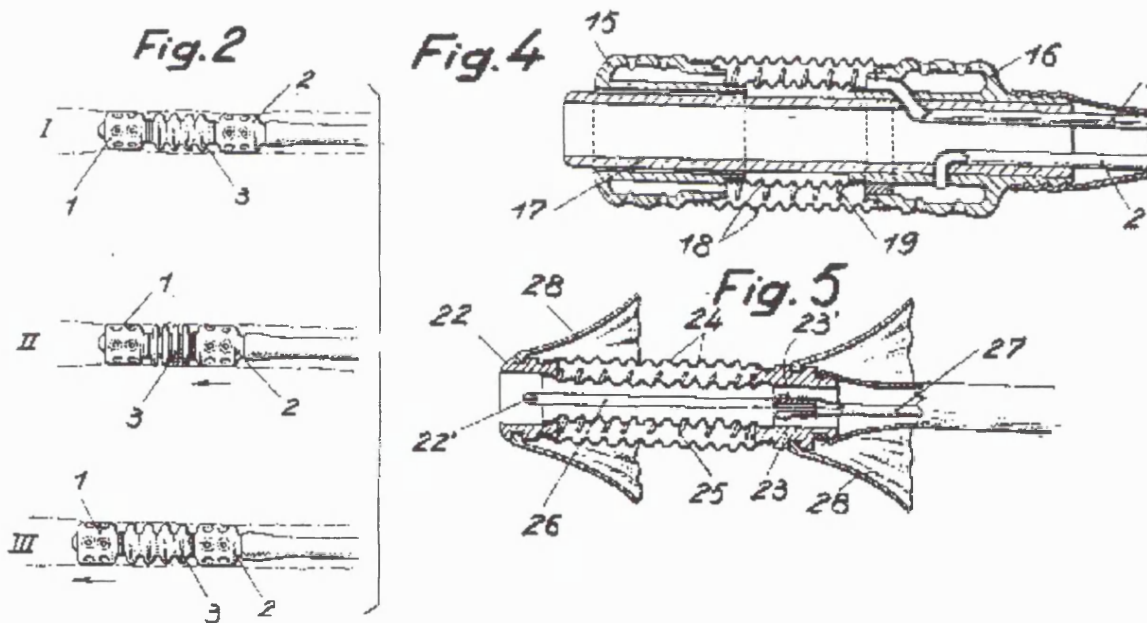


Figure 5.14ps Figures reproduced from the 1961 patent
"Perfectionnements aux cathéters médicaux"

Design and construction of prototypes, - suction crawlers using Bowden cables

A bicycle brake is operated by a Bowden cable. The cable consists of a core that can be pulled through an outer tube which is flexible but of fixed length so that when one end of the core is pulled back out of the tube, the other end is also pulled back. The suction crawlers described in this section use a Bowden cable to move the heads together and apart in much the same way that bellows were used in the last section. Figure 5.15 is a composite photograph showing the same suction crawler in the extended and contracted states as well as detail of the heads and cable, while Figure 5.1 is reproduced on the next page.

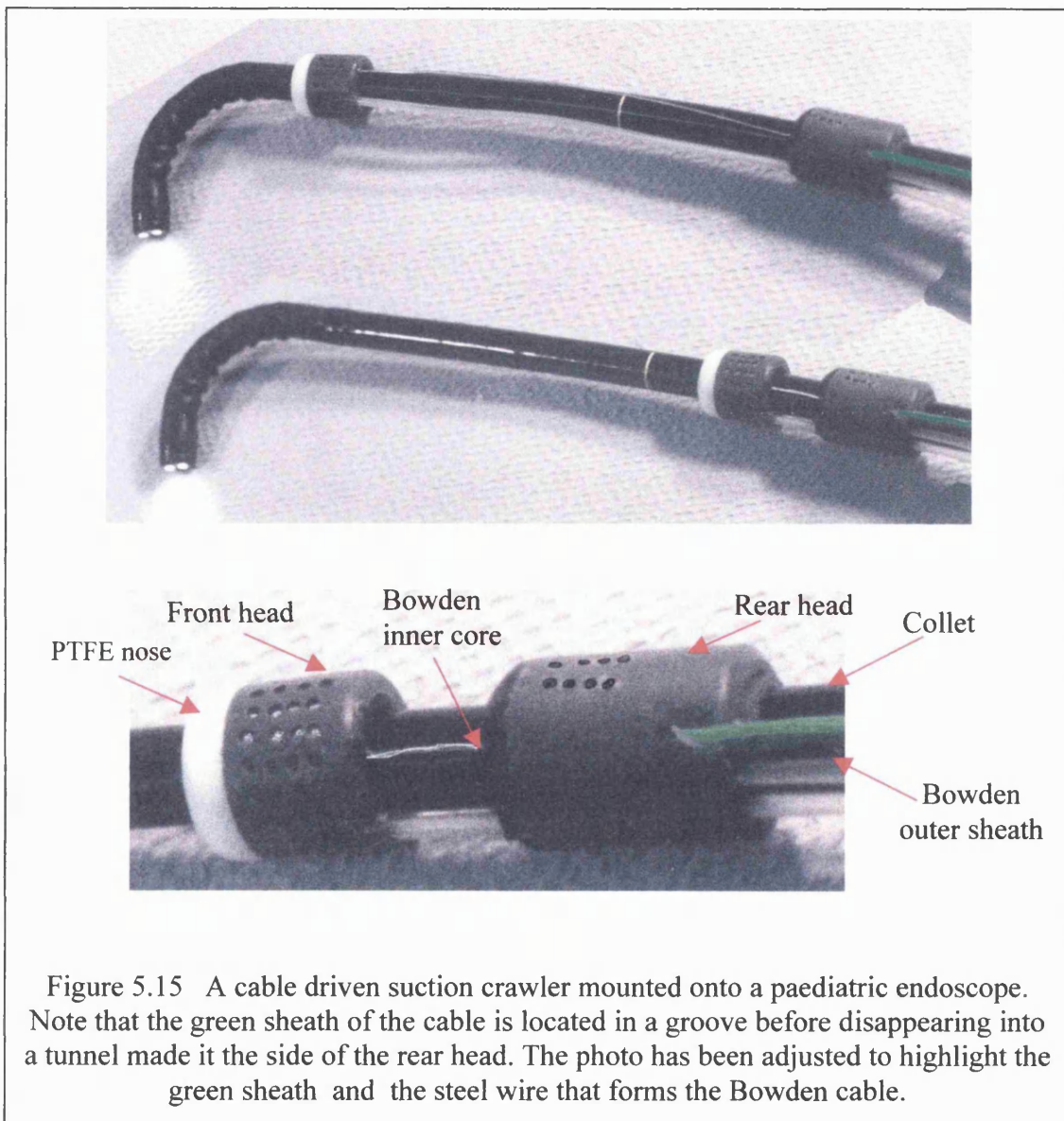


Figure 5.15 A cable driven suction crawler mounted onto a paediatric endoscope. Note that the green sheath of the cable is located in a groove before disappearing into a tunnel made in the side of the rear head. The photo has been adjusted to highlight the green sheath and the steel wire that forms the Bowden cable.

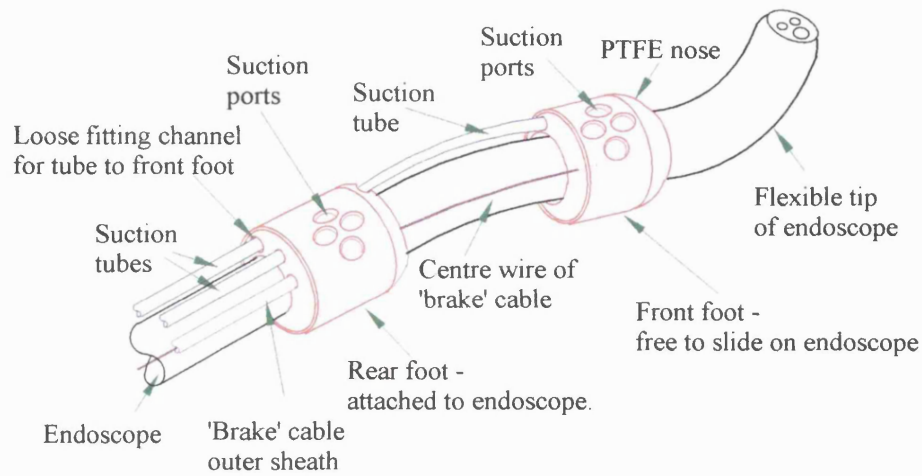


Figure 5.1 A suction crawler mounted onto an endoscope (reproduced from start of chapter)

It can, with difficulty, be seen on the photograph that the rear suction head is attached to the endoscope with a collet while the front suction head has a large internal diameter so that it can slide up and down the shaft of the endoscope. The system is positioned as close to the front of the endoscope as is possible without the front head sliding over the steering section at the tip of the endoscope, which can be bent to a radius that is too tight for the head to be pushed around.

When the wire is being pulled, so that the gap between the heads contracts, the situation is the same as for a bicycle brake and the cable is capable of delivering ample force. Even when very large forces are applied, the outer tube, which is in compression, does not buckle because the cable running through it is in equal and opposite tension. However, when the wire is being pushed so as to extend the gap between the heads, the inner core is in compression and the part of it that extends beyond the outer sheath is unsupported and will buckle if too much force is used, particularly when the cable is following a bend in the shaft of the endoscope. There was therefore a requirement for the wire to be rigid enough to push the front head forward against the resistance of the surrounding colon, but at the same time sufficiently flexible not to increase the stiffness of the endoscope significantly. Tests were made with a range of 'hard' stainless steel wires (diameters; 0.35, 0.5, 0.6, 0.8, 1.0, 1.25 mm, KC Smith Ltd, London) and it was apparent that 1 mm diameter was too stiff and 0.4 mm diameter too flexible, but that 0.6 mm diameter felt appropriate and so was used for all the devices that were made.

In principle it would be possible to replace the Bowden cable and the two suction tubes with a single coaxial pair of tubes. The inner tube would be attached to the front suction head and could be used to push and pull it as well as carrying air or water to and from it, while the outer tube would be attached to the rear head like the Bowden outer tube. Air and water for the rear head would be carried in the annular gap between the tubes. Although such an arrangement would be very neat, it was not pursued because it does not affect the basic principle.

Although the principle of operation is simple, there are more stages in each cycle than might be expected. Table 5.3 below summarises the stages taking as its starting point that the endoscope and attached crawler have been inserted into the colon with the heads close together. The term ‘neutral’ refers to the situation when neither suction nor inflation nor water flush is being applied.

Step	Front head	Cable	Rear head
1	Neutral	Contracted	Sucking
2		As above	Tissue caught in chamber
3	Neutral	Pushing forward into extended position	As above
4	Sucking	Extended	Water flush
5	Tissue caught in chamber	As above	Inflate until lumen is open
6	As above	Pulling the heads together, - contacting	Neutral
7	Water flush	Contracted	Sucking
8	Neutral	Contracted	Sucking

Table 5.3 The stages involved in advancing one step

It would be possible to automate this process but to save time and expense a unit was built that left the operator’s hands free by allowing him to use his feet to switch the vacuum and inflation between the two suction heads, so as to control the rate of inflation and to extend or contract the Bowden cable. This worked well, but the feet only operation was abandoned when water flushes were added to both lines and, to keep the system simple and inexpensive, standard manually operated syringes and fittings were used. Figure 5.16 is a schematic diagram of the system.

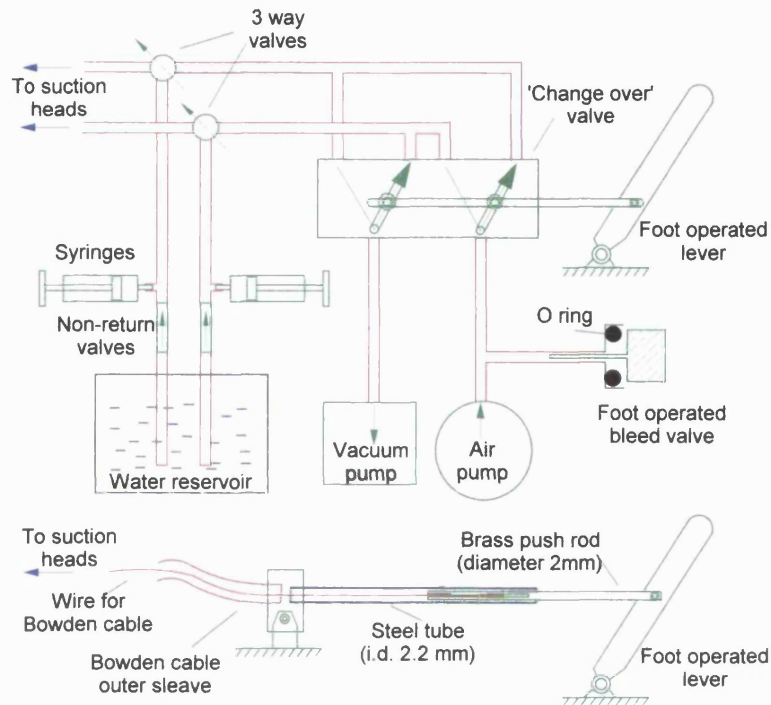


Figure 5.16 Schematic diagram of the valve unit

5.4 Methods used for constructing cable driven suction crawlers

The method for making a cable operated suction crawler will now be described before moving on to the results obtained using these devices.

The first cable driven suction crawlers that were built were not mounted onto endoscopes but, as shown in Figure 5.17, had a central Bowden cable with two heads fixed to it. This worked well on straight or gently curving sections of excised colon but when it came to a sharp bend it would bury its nose into the tissue and push out a bulge before turning. The

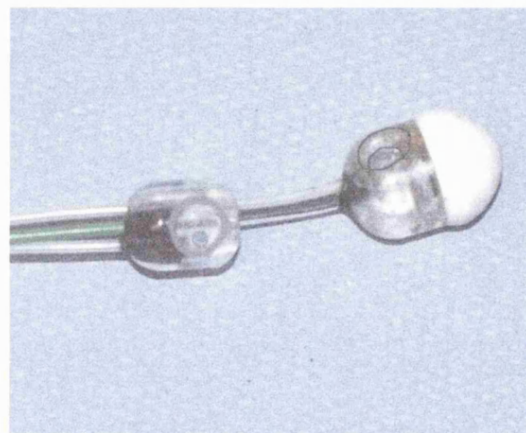


Figure 5.17 An early prototype cable driven suction crawler.

problem was that once it was pushing blindly into a bulge there was no particular reason for it to turn one way rather than the other and sometimes it would turn the wrong way and try to come back along the lumen towards its own tail.

It may be that persevering and using slightly less flexible wire as the inner core for the Bowden cable would have overcome this problem. However it appeared that the crawler needed to be constrained to move in the right direction and this could best be achieved by fixing it to an endoscope. Figure 5.18 is a drawing of a second generation model that had rear facing suction ports. Rear facing ports had worked well with bellows but, as was mentioned earlier, it was necessary to allow about three millimetres of land around the entrances to the chamber so that the tissues were not bent away from the edge of the chamber too sharply. It was discovered after making this prototype that if insufficient space was left, the tissues tended to peel off the suction chambers when the colon was inflated.

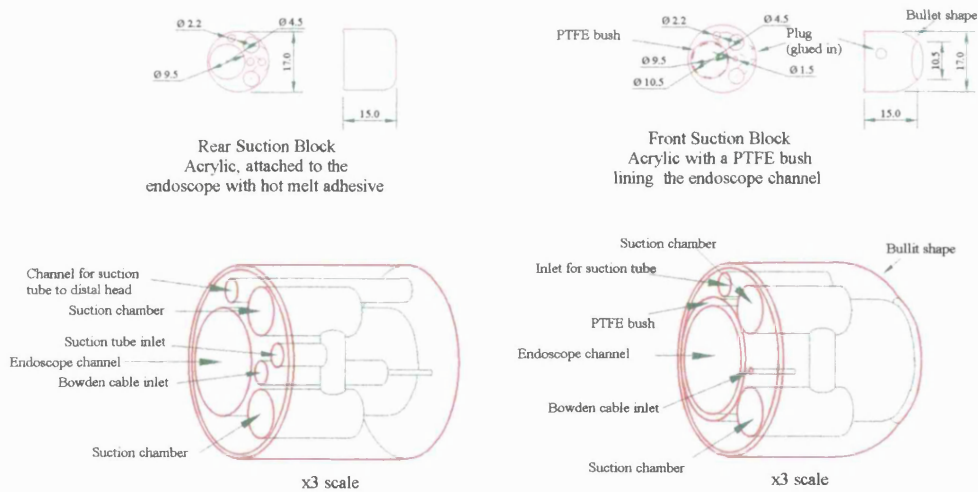


Figure 5.18 Second generation suction crawler. The nose and tail pieces for an endoscope mounted suction crawler with rear facing ports.

Although the polished acrylic slid freely over the tissues, it tended to stick against the plastic coating of the endoscope as the front head was pushed forward. Adding a PTFE bush prevented this from happening and, so long as the acrylic was roughened and the bush was an interference fit, the PTFE bush could be retained in place using Loctite 480 rubber toughened cyanoacrylate adhesive with a Loctite 770 polyolefin primer.

This design was easy to build but its performance in simple models was disappointing as the tissues tended to peel up from the suction ports when the colon was inflated, particularly if the device was advancing around a bend with the ports on the inside (i.e. the bunched up side). It was therefore decided to change to a more complex design that would allow the heads to have radial suction chambers, as has already been seen in Figures 5.1 and 5.15.

5.4.1 Method for making the third generation cable driven suction crawler

Figure 5.19 is a drawing of the latest design of crawler that used four relatively large (4 mm diameter) radial suction ports clustered together. No attempt was made to create an hygienic design that could be cleaned and reused in a clinical environment partly because it was difficult enough to make the heads anyway and partly because Bowden cables are inherently dirty after use and would probably force any clinical product to be a disposable.

The front suction head was made by gluing a PTFE nose and throat, shown in red, to a PVC outer skin and tail, shown in green. Since the suction tended to pull the component parts together, the demands on the glue were not great and the Loctite 480 with Loctite 770 primer was sufficient. These two components were shaped so that the gap between them formed an annular chamber from which air could be sucked through a nylon vacuum tube. This tube entered the chamber through a tight fitting hole into which it was glued with a waterproof epoxy (Super Steel, Loctite UK, Welwyn Garden City). Initially, the bond between the nylon and the PVC was too weak and the strength of the join had to be improved by threading the PVC (10 BA) and roughening the nylon tube so that the epoxy could grip them mechanically.

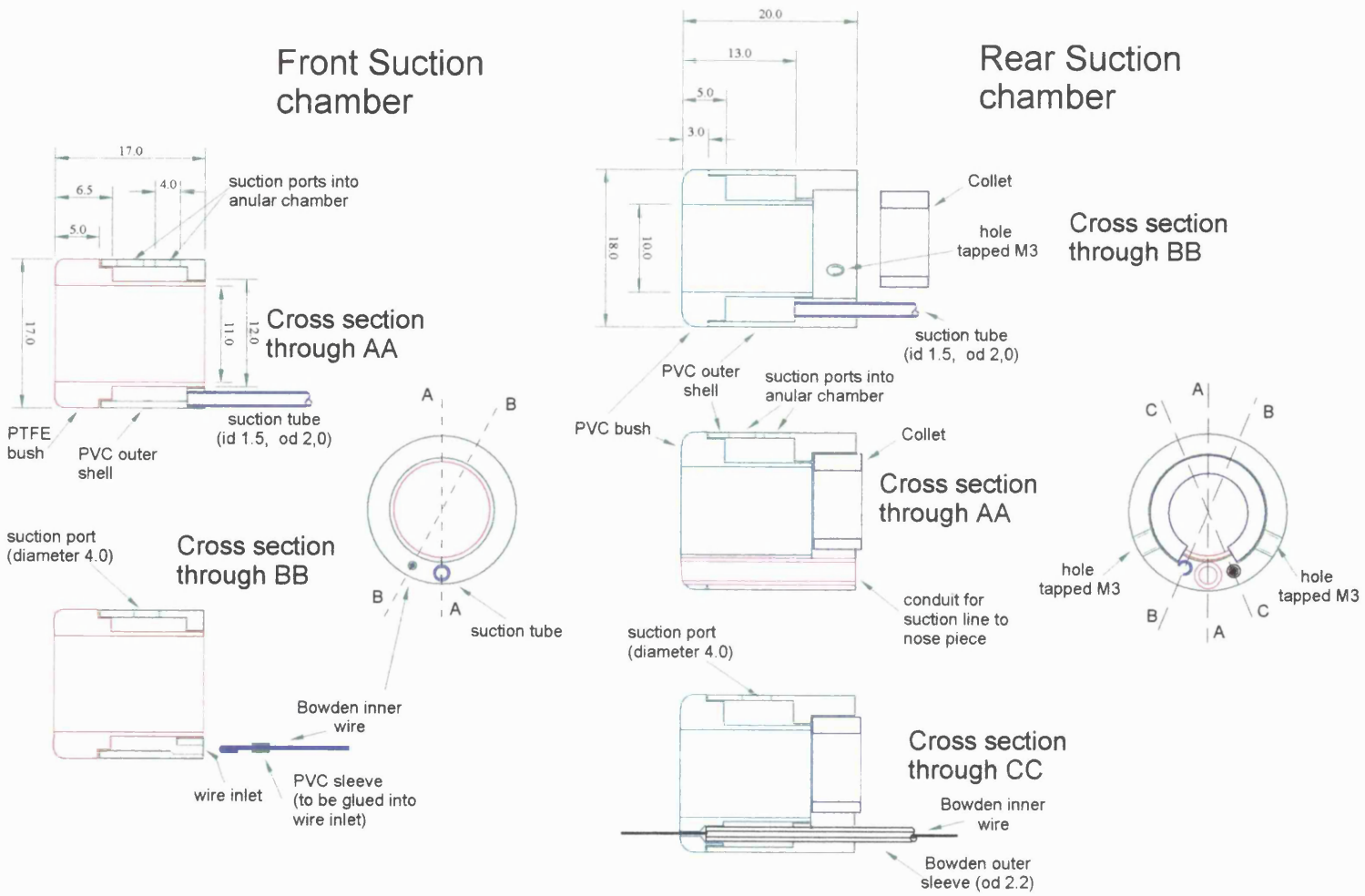


Figure 5. 19. Third generation suction crawler with radial suction ports. The left hand half of the drawing shows the nose piece, the right hand half shows the tail piece.

The vacuum chamber had four circular ports each of 4 mm diameter arranged as a cross (⊕) on one side of it. The number of ports was a compromise between on the one hand maximising the area so as to maximise the grip and on the other hand being aware that each extra port increased the likelihood of one of them leaking and destroying the suction for all of them. The holes were clustered together because it had been observed that leaking tended to happen when the sucker was trying to grip the crumpled tissues on the inside of a bend and if the holes had been evenly spaced around the chamber then the probability that one hole was on the insides of a bend would be increased. It is an annoying feature of the system that the suction is only as good as its weakest link, if one port leaks then they all lose vacuum.

The 0.6 mm diameter stainless steel wire that formed the inner core of the Bowden cable required a relatively strong attachment to withstand the load as the endoscope was dragged forward. This was achieved by folding the tip of the wire over on itself so that it formed a fat head that could be pushed into a blind hole in the PVC and trapped there with a PVC collar welded into the inlet of the hole by a solvent adhesive (Liquid Weld, Caradon Terrain, Aylesford, Kent, UK).

Moving now to the rear suction head, the principle was similar except that the head did not slide along the endoscope and so there was no need to use PTFE. Instead the nose was made from PVC which can be easily and reliably solvent welded to the tail. As before, the nylon tube delivering suction, air and water was mechanically bonded in place using epoxy.

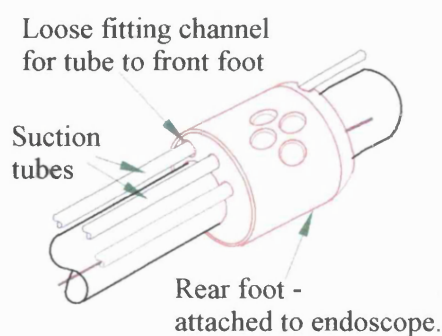


Figure 5.20 Detail from Figure 5.1 showing the suction tube for the front foot passing through the rear foot.

The rear suction head has to let the suction tube for the front head slide freely back and forth even when the rear head is sucking the tissues. This was achieved by making a conduit for the suction line out of a rod of acetyl copolymer that had been machined into a thin walled tube (I.D. 2.8 mm and O.D. 3.1 mm). This tube (shown

in pink on the section through AA in Figure 5.19) slid into a hole drilled through the tail, the vacuum chamber and the nose and was retained by a smear of cyanoacrylate. The smear of glue also provided a seal around the conduit that prevented leaks into the annular vacuum chamber.

The outer sleeve of the Bowden cable (Bard Interventional Products, Mentor OH, USA) is made from tightly coiled wire enclosed in an FEP (fluorinated ethyl propylene) sleeve and is shown in black in Figure 5.14 (section through CC). In order to glue the cable in place the FEP sleeve was stripped off the last fifteen millimetres and replaced with an equal length of PVC tube (O.D. 3.0 I.D. 2.0 mm) that is attached to the coiled wire with epoxy. This PVC tube can then be pushed into a previously drilled hole and bonded in place with a solvent. It can be seen on the drawing that the front of the hole is stepped down to a 1 mm diameter to allow the inner wire of the Bowden cable to slide freely.

Finally the method for fixing the rear head to the endoscope will be described. There was concern that glues such as hot melt adhesive would damage the lacquer coating on the endoscope and that clamping the head directly onto the shaft with grub screws might scratch the surface or even cause deeper damage. It was therefore decided to make a collet that would fit onto the endoscope and could then be gripped and squeezed tightly shut by grub screws located at the back of the rear head. The collet consisted of a 270° arc of PVC (shown in dark blue on the drawing) that was made slightly undersized so that it had to be sprung onto the endoscope. Once the clip was positioned on the endoscope shaft the rear suction head could be slid over the clip and the two M3 grub screws tightened.

5.5 Experiments and results with prototype suction crawlers using cables.

The Bowden cable driven suction crawlers suffered from a frustrating number of mechanical failures such as the changeover valve leaking or the Bowden cable becoming disconnected at either end or, even more frustratingly, the inner wire of the cable being kinked in transport. These difficulties made it hard to judge what were inherent weaknesses and what was simply the result of gimcrack construction.

The first tests of cable driven suction crawling with the 'S' bend model (described in Appendix 1 section A3) used a prototype suction head attached to an elderly Olympus CF1T1 endoscope. The prototype was similar to that illustrated in Figure 5.14 except that it had 16 x 3mm diameter holes on each head and had to be large enough to fit over the relatively fat endoscope (diameter 14.5 mm). In order to keep the overall diameter of the heads to 20 mm the annular gap between the inner and outer shells was only 1.5 mm. Prior to testing in the model, the force required to pull the front head out of a length of colon with the suction operating was measured four times consecutively and found to be 11.5, 5.5, 11 and 11 Newtons .

However, it became apparent when testing the prototypes in models of the colon that measurements, such as those described in the paragraph above, carried out in straight sections of colon overstated the grip obtained in practice. This was because the weakest grip tended to be on the inside radius of bends where the suction chamber is trying to grip crumpled tissues. *In vivo* it is unlikely that tissues would be crumpled in this way and there might be less of a problem, although, of course, the tone of the muscle and the quantity of mucus etc. might introduce other problems.

The crawler was used on different occasions with two separate lengths of colon. On both occasions the full length of the model was traversed three times with gentle pushing being used to help progress as the tip advanced around the second loop of the 'S' bend. The experiments were a success in that the entire length of the model was endoscoped without torsion or the need to "pull back" and, more importantly, with only gentle pushing that did not stretch the nylon stocking ("mesenteries") that retained the colon. Against this have to be set some disadvantages; torque could not be applied without winding up the Bowden cable and at difficult places there was quite a lot of 'dragging the anchor' so that progress was only two or three centimetres per step. The notes taken at the time record that it was "a lot of hassle". By contrast, the notes from the same session relating to the bellows system say "worked very well indeed".

Following these initial tests the prototype illustrated in Figure 5.14 was built for use with a relatively new Pentax FG29 endoscope that was lent us by the Gastrointestinal Research Unit at the Royal London Hospital. This endoscope is considerably smaller and lighter than the Olympus CF 1T1 and it slides more freely along the tissues. It has been

used with excised colon in the 'S' bend model for two sessions. On the first occasion it was used a number of times and worked well, the only negative factor being that conventional push colonoscopy also became easier with the newer endoscope.

On the second occasion there was a shortage of colon tissues and a piece was reused that had been defrosted twice before and was rather grey and lacking in mucus. It was still possible to reach the "caecum" with conventional endoscopy but it was necessary to push very hard. The problem was worse with the suction crawler which stuck about half way around the second bend and no further progress could be made despite lubricating with water and using inflation. The tip of the endoscope advanced about five centimetres each time the front head was attached to the tissue and the cable contracted, which was good. However as soon as the suction was switched away from the front head, the tissue jumped forward again and the progress was lost. It was unfortunate that the valve system switched off the suction to one head before it switched it on at the other.

The valve system was subsequently modified so that suction could be switched on or off to either side independently. It was also decided that it was confusing to have the choice of sucking, blowing or water flushing through either head and that it would simplify matters if the ability to blow air through the heads was removed. From now on the tissue could be released from the suction heads by flushing 5 ml of water through the suction head, rather than by pumping an unspecified amount of air through the head. The colon could be inflated in the conventional way, via the endoscope.

The system was then attached to the Pentax FG29 endoscope and used once again with the 'S' bend model. As before, defrosted colon was used, but this time the piece was in good condition and had only been used once before. The crawler was used twice on the same piece of colon and both times it was possible to make steady progress along the colon until the caecum was reached. Although it was steady, the progress was very slow, taking about twenty minutes to achieve what could be done in a couple of minutes with conventional endoscopy. This was largely because of the "hassle" involved in operating the valves, flushing the lines and advancing and retracting the Bowden cable.

It was also apparent that the Bowden cable inner wire was too springy when it had to push the front head forward around a tight bend. Instead of pushing the front head

forward by about 100mm, it would bow, so that no more than about 50 mm progress was made.

The suction crawler on the Pentax FG29 was used once *in vivo* in a pig's bowel. However problems with 'prepping' the bowel meant that only a few centimetres proximal to the anus had been cleared of faeces and only two complete steps were taken. These were successful and no damage was visible although some red marks were just visible. The author has been told that Dario's group⁷ have found that these red footprints (or love bites) may be confused with significant pathology as the endoscope is pulled back along the colon after it has been fully inserted.¹¹

5.6 Conclusion

Suction offers what appears to be a safe method of obtaining a foothold on the bowel wall that allows a device to crawl forward. Furthermore, devices using concertina bellows appeared to be remarkably good at following the lumen without the need for steering, although this was not tested with colons that had diverticula. A problem in principle with suction crawling is that it leaves behind "love bites" that may be confused with serious pathology although it is possible that endoscopists could learn to spot the differences between serious and trivial pathology.

The major problems with suction crawling are the practical ones. It seems that bellows cannot be used as an add-on to existing colonoscopes so that, if they are to fulfil all the functions of existing colonoscopes, novel systems for collecting biopsies etc. must be developed. Dario's group are engaged in doing this and it will be interesting to see whether their robotic devices are effective. In the nearer future, bellows systems might have applications with purely visual systems for screening or, possibly, they might be used to drag a guide wire around the colon and anchor it near the caecum so that the colonoscope could be guided up along the wire.

Cable driven devices that attach to endoscopes help by providing traction near the tip but have the inherent disadvantage that they increase the width of the endoscope and the complexity of the system. At this stage of the development, the inconvenience and

unreliability outweigh the benefits but with automation it may be that the balance would tip the other way, at least for difficult procedures.

6 Stimulating the muscles of the GI tract so that they propel the endoscope

6.1 Introduction

In Bologna in 1786 Luigi Galvani obtained muscular contractions in a frog by touching its nerves with a pair of scissors during a thunderstorm. Similar contractions were produced using Leyden jars (capacitors) and machines for generating static electricity and by 1791 Galvani felt sufficiently confident of his findings to publish the essay *De Viribus Electricitatis in Motu Musculari Commentarius*. In this essay Galvani described experiments in which contractions were caused when metals were used to connect nerves to muscles and he concluded from this that the body could generate “animal electricity” without an external source. This work is not only seminal for electrophysiology; in Pavia Alesandro Volta suspected that “animal electricity” was an artefact caused by the metals used in the instruments and to show this he experimented with dissimilar metals in salty liquids. He thereby invented the Voltaic pile that by providing a source of direct current initiated the electrical revolution of the 19th Century. Despite Volta’s suspicions Galvani was able to show that even with a single metal it was possible to connect a nerve to a muscle and produce contractions though he was wrong in believing that “animal electricity” was fundamentally different to other types of electricity.

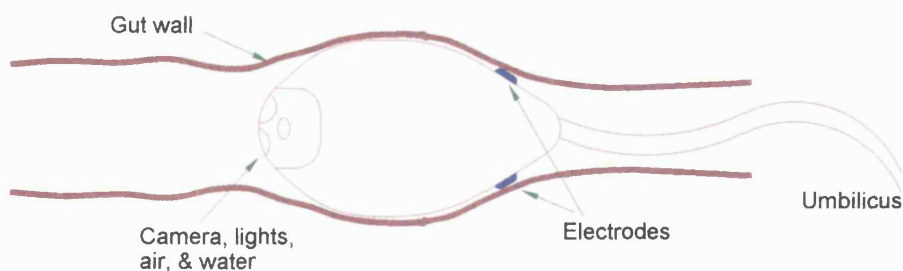


Figure 6.1 A device that propels itself forward by electrically stimulating contractions of the gut.

This chapter investigates the possibility of electrically stimulating the smooth muscles of the gut to contract and so squeeze along a lozenge shaped endoscope in much the same way that natural peristalsis propels a bolus of food. This approach, which was suggested by Dr Mills, is illustrated in Figure 6.1. The principle is that the uninflated gut clings to

the lozenge and makes contact with the two electrodes so that when a voltage is applied it causes a current to flow through the wall of the gut causing the muscles of the wall to contract and squeeze the lozenge forward, thereby bringing new tissues into contact with the electrodes. These new tissues in turn contract and so the lozenge advances smoothly along the gut. Once the device has advanced sufficiently far along the colon or small bowel the current is switched off and the bowel is inflated so that it can be viewed with the camera as the endoscope is pulled back. It should be noted that the idea is not to stimulate the autonomic peristalsis of the gut but to directly stimulate the local muscles and nerves to produce a local contraction which is propagated by the electrode being pushed along the tract.

The chapter starts with a simple description of the physiology of smooth muscle contraction followed by a review of relevant literature. The main sections of the chapter then describe the prototypes built and the experimental results obtained. Finally there is a brief conclusion.

Before starting the author would like to mention that his only previous experience of electrophysiological experimentation was when he was aged 12 and his older brother obtained an antique mahogany encased electrical stimulation machine. This consisted of a hand crank that drove a generator which was connected by two silk covered wires to a



Figure 6.2
The medical magneto stimulator

pair of brass tubes. The victim, with moist hands, gripped the tubes while the experimenter cranked furiously causing tremors and a painfully strong tingling sensation. We soon discovered that by connecting the brass tubes to the hand generator of an army surplus field telephone the victim could be 'frozen' so that he was unable to let go of the brass tubes or move his arms. A persuasive school friend managed to get the entire

top deck of a bus to hold hands while he maniacally cranked the phone but, fortunately, the resistance of so many hands held in series meant that only a mild tingling was produced.

My brother still owns the stimulator and my son has taken it to his school to excite a new generation of school children. Figure 6.2 reproduces a photo of it and Figure 6.3 is taken from the chapter 'Making and Overhauling a Magneto-electric Machine' in 'The Amateur Mechanic'¹ (the next chapter is 'Making a Leather Suitcase'!).

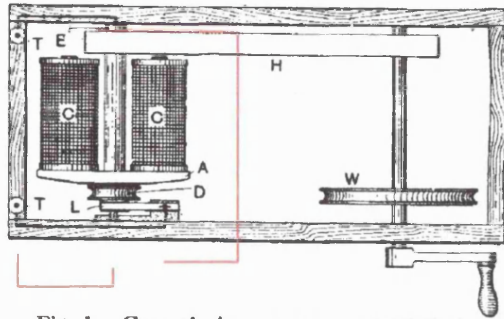


Fig. 1.—General Arrangement of Medical Magneto-electric Machine

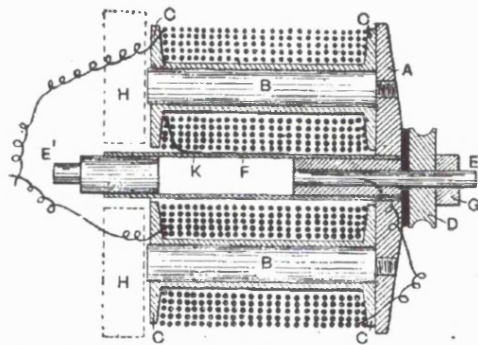


Fig. 2.—Armature of Magneto-electric Machine

Figure 6.3 Diagram of medical magneto taken from reference 1

H = magnet, T = connectors to hand bells
C = coils W, D = pulley system

NOTE The original diagram has the circuit drawn erroneously, the red lines show the correct circuit.

it was lucky that we did not produce fibrillation with it as, according to IEC 479, a current of 50 mA at 50 Hz for more than one second gives a 5% chance of fibrillation rising to a 50% chance at about 80 mA.

When the output from the stimulator is viewed on an oscilloscope it can be seen that, with a load of 1 k Ω , the waveform consists of two sharp spikes per revolution each of about 100 V amplitude but only 50 μ s duration. The brevity of the spikes ensures that the machine is safe and will not cause fibrillations of the heart. This waveform is achieved by having a sprung circuit breaker which rests on the shaft supporting the coils and provides a short circuit bypassing the patient (or victim); however there are two flats on the shaft so that when it is rotating reasonably fast the circuit breaker loses contact twice per revolution and a surge of current flows through the patient.

The telephone generator has long since been lost and the author does not know what waveform it produced. In hindsight

6.2 Simple physiology

This section is culled from a medical text book², an electro-chemistry book³, and an encyclopaedia⁴. It may be of interest to those, such as the author, who know almost no physiology. It starts with a somewhat engineering approach to ions and membranes before moving on to physiology.

Nerves and muscles are made up of cells that are electrically 'excitable' and can propagate electric signals around the body or neighbouring muscle cells. Like any electric system this activity can be described in terms of currents and voltages, however the situation differs from metallic conduction in that the electric currents are flows of ions and the potential differences across membranes arise from differences in the concentrations of ions.

There is only one type of electron but there are many types of ion and for someone used to wire circuits this adds an extra dimension; it is necessary to think in terms of chemical concentration gradients as well as electrical potential gradients. If an impermeable membrane separates two solutions one of which contains sodium ions (Na^+) and the other of which contains an equal concentration of potassium ions (K^+) then there is no electric difference across the membrane but there are chemical gradients. If holes are now made in the membrane to make it permeable, then ions will diffuse through the holes until the solutions on either side of the membrane are the same and, since the ion concentrations on either side are the same, there is still no electric potential difference (P.d.) across the membrane.

As well as permeable and impermeable membranes it is possible to make 'semipermeable' membranes that are permeable to one type of ion but not to another. Suppose that the sodium and potassium solutions are now separated by a membrane, such as the wall of a muscle or nerve cell, that allows only potassium ions to pass and blocks sodium ions as well as anions (e.g. Cl^-). Initially the solutions are in electrical equilibrium but as the K^+ ions diffuse down the chemical gradient so electrical current flows across the membrane and a potential difference develops which, since the membrane is impermeable to other ions, is not counteracted by any other currents. The system comes into equilibrium when the electrical gradient pushing the ions in one

direction balances the chemical gradient pushing them the other way. For dilute solutions the relationship between voltage and concentration is described by the Nernst-Planck equation; ~

$$\text{P.d.} = \left(\frac{RT}{zF} \right) \ln \frac{c_2}{c_1} \quad \text{Eq 6.1}$$

Where P.d. is potential difference,

R is ideal gas constant

T is absolute temperature

z is ionic valence

F is Faraday's constant

c_1 and c_2 are the concentrations of the ion either side of the membrane.

For ions of single valence at 25°C it works out that a ten fold difference in ion concentration is balanced by a P.d. of 59 mV.

Just as it requires energy from a battery or generator to establish potential differences around a wire circuit, so energy is required to 'pump' ions (or molecules that produce ions) across a membrane and so establish the concentration gradients that drive bio-electricity. The chemical pumps that actively transport sodium and potassium ions across a cell membrane are fuelled by ATP and pump three K^+ into the cell for every two Na^+ pumped out of the cell. The pumps produce a "pressure head" of about 60 mV for Na^+ and about 90 mV for K^+ .

6.2.1 Cell membranes.

Turning now to physiology, the wall of a nerve or muscle cell is made from an extremely thin membrane made of phospholipids that are waterproof and resistant to Na^+ , K^+ and Ca^+ ions. However there are proteins embedded into the membrane through which ions can be pumped or allowed to diffuse. Some of these proteins form ion selective channels that are specific to a particular species of ion and can be rapidly opened or closed, the opening and closing being controlled by chemical messenger molecules or by the electric P.d. across the membrane in the region of the channel.

Ion pumps in the cell pump potassium (K^+) into the cell while pumping sodium (Na^+) out of the cell. Under resting conditions some of the channels that allow K^+ to pass (but not its anions) are open and the potassium ions that have been pumped into the cell flow out down the chemical gradient, making the inside of the cell more electrically negative. By contrast, most of the channels that allow Na^+ through are closed during resting so that only a little Na^+ flows into the cell carrying positive charge with it. On its own the relatively free flow of K^+ out of the cell would go on until the electrical gradient reached a P.d. of -90 mV so that it balanced the chemical gradient established by the pumps. However, the restricted flow of Na^+ into the cell somewhat offsets this so that the 'resting potential' is -70 mV (negative) with respect to the surrounding bodily fluids. In the resting state the membrane is said to be 'polarised'.

The resting potential of the cell remains stable at -70 mV until a chemical or electrical stimulus arrives which is capable of opening the Na^+ channels. To be capable of opening the channels an electrical stimulation must be sufficiently positive to raise the potential of one area of the membrane to at least $+20$ mV with respect to the inside of the cell. Once the Na^+ channels are open, positive charge floods in, making the membrane nearby more positive so that more channels open, allowing even more positively charged sodium in. The process spreads like an avalanche and the inside of the entire cell membrane rapidly becomes positive with respect to the surrounding liquid, reaching a peak potential of about

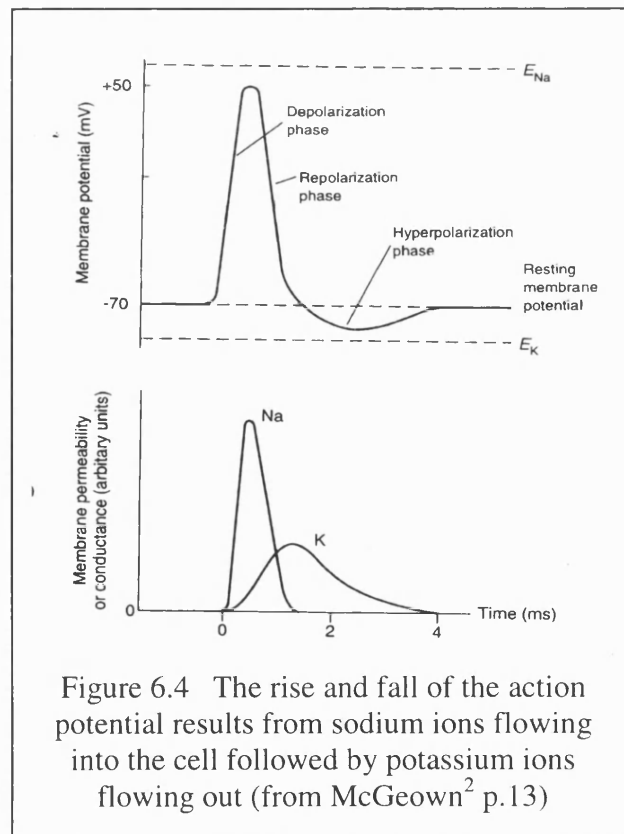


Figure 6.4 The rise and fall of the action potential results from sodium ions flowing into the cell followed by potassium ions flowing out (from McGeown² p.13)

$+50$ mV with respect to the surrounding fluid. This positive potential is called an 'action potential' and while it is present the membrane is said to be 'depolarised'.

As is shown in Figure 6.4, the Na^+ channels only remain open for about one millisecond and then close. Meanwhile extra K^+ channels open, allowing an extra high rate of potassium flow out of the cell and driving the potential more negative with respect to the extracellular fluid. This extra negative, 'refractory' period prevents the positive charge from neighbouring areas of the membrane from retriggering another action potential in an area that has just fired. In other words, it ensures that the avalanche flows away from a depolarised area rather than rumbling back and forth over it.

6.2.2 Muscle contraction.

The sudden change in the chemical and electrical environment within a muscle cell causes it to contract and the following paragraphs are a grossly simplified description of the contractile mechanism for smooth muscle such as that found in the small and large bowels.

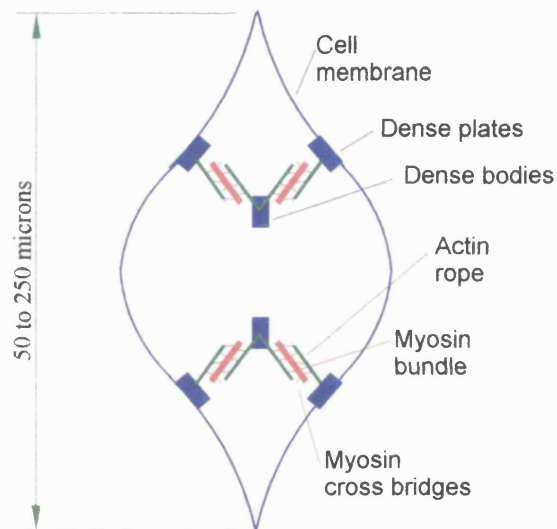


Figure 6.5 The contractile elements of a smooth muscle cell.

Figure 6.5 is a schematic representation of a smooth muscle cell. It shows that rope like structures made from a protein called actin extend inwards from dense plates on the cell membrane. Similar actin ropes extend out towards the membrane from dense bodies anchored near the centre of the cell. If these ropes are pulled past each other so that the dense plates on the surface are pulled towards dense bodies in the centre, then it can be seen from Figure 6.5 that the cell is pulled into a shorter, fatter shape. In other words, it contracts.

The pulling of the actin ropes is performed by bundles of a protein complex called myosin that lie beside the actin ropes. The myosin attaches to the neighbouring actin ropes with strands of proteins, called 'cross bridges', and these can be seen schematically in Figure 6.5. Although they are called 'bridges,' the fragments of myosin that link

across to the actin are more like arms in that when they are activated they reach forward, grab a piece of the actin rope, pull it back, let go and then repeat the cycle. Myosin is the motor that drives cell contraction and hence muscle contraction.

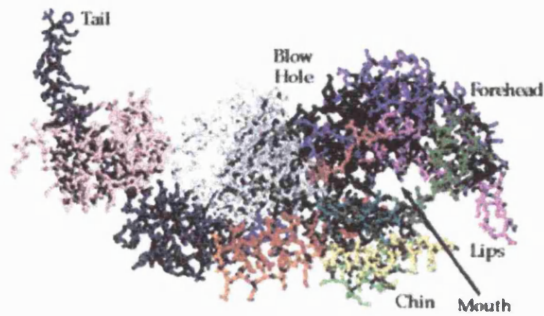


Figure 6.6 The myosin whale from Bruce Patterson's web page⁵.

Although the fragment of myosin that grips and pulls the actin is called a bridge and behaves like an arm, it looks like a whale. Figure 6.6 is taken from a Web page prepared by Bruce Patterson at the University of Arizona⁵ and shows the structure of the cross bridge for chicken myosin with different colours representing different proteins. Patterson

entertainingly points out that the analogy with a whale can be taken further with the region that looks like a mouth being the part that does indeed lock on to the actin. The tail is the part that is attached to the rest of the myosin bundle and, it is hypothesised, curls up to drag the actin backwards. The ATP that provides the energy for this is sucked in through the blow hole and it is converted to ADP and inorganic phosphate in a kind of chamber formed just below the blow hole.

Brief descriptions have now been given of the electrical activation of cell membranes and of the mechanism whereby cells contract. It remains to describe how these two processes relate to each other.

6.2.3 *Activation of smooth muscle contraction.*

Muscle cells are activated when an action potential depolarises the membrane and allows changes in the concentrations of the ions within the cell. In smooth muscle, it is the concentration of calcium ions (Ca^{2+}) which controls the cycle of gripping, pulling, releasing and moving along the rope. When the action potential arrives voltage dependent calcium channels open in the membrane wall allowing Ca^{2+} to flow into the cell and this effect can be further amplified by these Ca^{2+} ions stimulating the release of further Ca^{2+} ions stored within the cell. The Ca^{2+} ions in the cell bind to a regulatory protein named calmodulin that in turn activates an enzyme called myosin light chain kinase (the light chain is shown in pink on the whale's tale) which causes phosphorylation of the myosin and thereby powers the gripping and pulling actions.

So far no mention has been made of how the action potential is transmitted from one cell to another. In some places smooth muscle cells within one section of tissue may be electrically linked through low resistance “gap” junctions so that an action potential will spread to other cells in the same way it spreads around the membrane of a single cell. By contrast nerve cells are not in direct contact with each other or with muscles cells and the junction between them is known as a ‘synapse’. When an action potential arrives at a synapse connecting a nerve to a muscle cell, it opens channels for Ca^{2+} to enter the nerve terminal which then opens ‘vesicles’ that secrete chemical messengers, such as the neurotransmitter acetylcholine, into the narrow (generally about 200 nm) gap that separates a nerve cell from a muscle cell. The transmitter diffuses rapidly across the gap and arrives at specialised receptor sites in the muscle cell wall that in turn open channels allowing sodium and potassium ions to flow across the membrane and so generate an action potential.

When, as in the experiments described below, an artificial electrode is being pressed into muscle it may be that it directly stimulates some cells. If this happens in smooth muscle, where the cells are in electrical contact with each other, then the action potential will run from one cell to the next and a whole area of muscle and attached nerves will be stimulated to cause contractions. Alternatively, it may be that the electrodes stimulate nerve cells which then transmit the stimulus to other nerves and to muscles which then contract. There is no easy way to distinguish at a macroscopic level between direct

stimulation and stimulation via the nerves; the simplest way would probably be to give a nerve blocking drug and then observe whether it prevented muscle contraction. In any event, most of the circular muscles and nerves in the small and large intestines run in helices, so stimulation of the muscle at one point produces a ring of contraction.

As well as being electrically fired, smooth muscle cells can also be triggered purely chemically. Their membranes contain receptors that once activated by a messenger, such as acetylcholine, release a second messenger into the inside of the cell which in turn triggers the release of Ca^{2+} from storage reticules within the cell so that the calcium ion concentration rises and, as before, the contraction cycle is set in motion. In principal it might be possible to make a chemically driven device version of the device, where the electrodes were replaced by nozzles that sprayed acetylcholine or a similar chemical. This chemical might then stimulate contractions that would squeeze the lozenge shaped device along the GI tract.

6.3 Literature review –

There is an extensive literature concerned with the electrophysiology of the gastrointestinal tract and indeed the *in vivo* experimentation for this project was undertaken at the Gastrointestinal Research Unit at the Royal London Hospital which is most eminent in this field. However most of the literature is concerned with studying motility and the autonomic nervous system rather than directly stimulating the tract with electrodes. The following paragraphs briefly describe some of the work that has involved actively applying voltages to stimulate the muscles of the gut. No effort is made to describe research involved with stimulating the gut to act as a pacemaker for normal peristalsis (e.g. Eagon and Kelly⁶) because our interest is in overriding natural peristalsis and being able to move the device in either direction along the tract.

A number of groups have been working on improving continence for patients whose anus and rectum have been surgically removed and replaced by a colonic or small bowel pouch. One approach, which (according to a review article in the British Journal of Nursing⁷) was pioneered at the Royal London Hospital, has been to make a replacement anal sphincter by removing the long slender gracilis muscle from the thigh and then

wrapping it around the cut off end of the colon which has already been sutured circumferentially onto a hole cut in the perineal skin. The gracilis muscle can then be continuously stimulated by electrodes except when the patient wishes to relax it and so empty the pouch.^{8,9,10} Williams⁸ mentions that after a few days the stimulator was set to deliver 2.5 V pulses with a duration of 21 ms at a frequency of 10 Hz, however the relevance of this to our project is limited because the gracilis is skeletal muscle and the electrodes were attached to the trunk of the nerve that controls it rather than to the muscle itself.

Of more relevance to the current project have been a number of studies into direct electrical stimulation of the small and large bowels. One of these was an attempt by the group at the Royal London to see whether smooth muscle from the bowel itself could be used instead of the gracilis to make a sphincter¹¹. At laparotomy they stitched strain gauges onto the colons of 21 rabbits and also used needles to attach pairs of fine wire electrodes as illustrated in Figure 6.7. Each rabbit had two pairs of electrodes attached four centimetres apart on its colon and a pressure gauge was inserted into the colon between the pairs of electrodes.

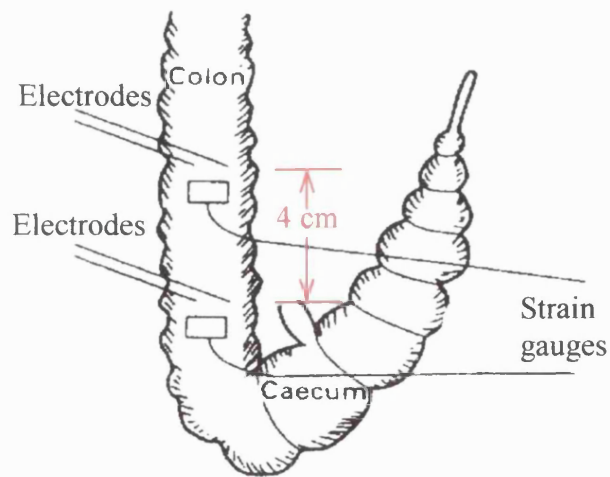


Figure 6.7 Sketch showing the positions of the electrodes and strain gauges attached to rabbit colons by Ratani et al. Reproduced from reference 11.

They report the intraluminal pressures measured at a range of stimulating voltages (10 – 14V), frequencies (2 – 10 Hz) and pulse durations (0.5 – 50 ms). Frequency has no effect but increasing the pulse duration or the voltage increases the strength of the contraction. With the duration limited to 1 ms to avoid bubbles forming and at a frequency of 10 Hz they report that the median pressure produced was 22 cm H₂O (2.2 kPa) with a 10 V (equivalent current 8 mA) pulse rising to 30 cm H₂O (3 kPa) at 14 V.

The same group had previously performed similar experiments when investigating the possibility of using colonic loops to form a neo rectum that could be electrically

stimulated to contract during evacuation and so increase the proportion of the contents that are expelled¹². They experimented with seven dogs and found the mean pressure produced was 114 cm H₂O (11.4 kPa) when the stimulator was set to give 0.5 ms pulses at 10 Hz with amplitudes of 15 V for four dogs, 18 V for one dog and 20 V for two dogs.

Several years before this, a group working in Cleveland and Vienna had performed similar experiments with a view to using ileal pouches to replace viscera such as the bladder or colon. The three papers^{13,14,15} that they published in 1988 and 1989 all describe similar studies using canine ilea with the electrodes, pressure sensors and EMGs arranged as shown in Figure 6.8.

Although the currents applied were similar to those described in the papers by the London group, they found that needle electrodes produced burning and they therefore changed to using large area (12 x 3 mm) electrodes, as illustrated, that were sewn in place. The function of the EMG electrodes appears to have been to allow the experimenters to predict the natural waves of peristalsis and so avoid taking measurements when they were due.

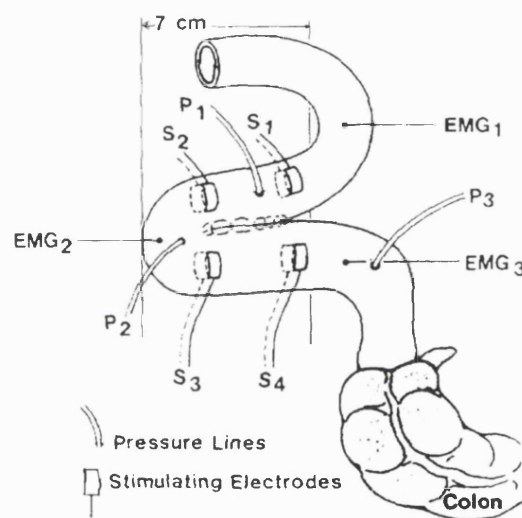


Figure 6.8 The configuration used by Grundfest-Broniatowski et al to study coordinated electrical stimulation of an ileal pouch.

In the first of their papers¹³ they report that in all the four dogs studied, stimulation at 6 Hz with 50 ms pulses was always effective in contracting the ileal pouch and squeezing liquid out of it. They present a table which summarises the pressures generated at different stimulating currents. The table shows that at 10 mA the intraluminal pressure rises by about 18 mmHg (2.4 kPa), at 15 mA it rises by about 33 mmHg (4.3 kPa) which is similar to the rise caused by stimulating with 20 mA. They also report that 100 ms pulses at 3 Hz were effective but that various stimulation sequences using pulses of 1 ms or less were ineffective at evacuating the pouches although they sometimes caused muscular contractions.

Much of their work is concerned with recording the differing results found by stimulating with different pulse lengths and repetition rates. Both the later papers deal with trains of pulses of less than 1 ms or of single shots with pulses of up to 200 ms. Pulses of less than a few milliseconds only stimulate the nerves and do not stimulate the muscles directly. When nerves are stimulated the situation is complicated as some nerves serve to inhibit the muscles and some to excite them, so the effect of a stimulation depends on the particular characteristics of the stimulating waveform as well on factors such as whether the animal has been fasted or fed. As would be expected, they report very variable results from stimulation of the nerves in the ileum and jejunum.

In the discussion section of the first paper they mention that there is a “potential problem” with “unwanted stimulation of the abdominal wall structure”. In one of the later papers¹⁵ they refer back to this paper and say that “this type of stimulation could not be used in awake animals due to heavy contractions of the abdominal wall.” Such side effects would be a major disadvantage for an endoscope driven by electro-stimulation, however the small distance between the electrodes on the endoscopic devices should limit the penetration of stray currents and, it is hoped, keep the contractions within the gut.

From the point of view of this PhD project their comment regarding anaesthesia is interesting, they say that “under Halothane induced anaesthesia we could not elicit any mechanical response” (reference 15, page 555). It will be seen later in this chapter that the pigs we used were anaesthetised using Halothane and Enflurane and yet they did respond to electrical stimulation, presumably because of the longer stimulation pulses that we used. However it is likely that the anaesthetic may have affected our results; according to Dr Mark Scott of the Royal London Hospital, it has been their general experience that Halothane approximately doubles the current required to evoke a response¹⁶.

There is a concern that electrical stimulation of the gut might be painful. The group at the London have experience of stimulating the rectum in conscious humans and report that currents of up to 15 mA are acceptable but that 35 mA proved most uncomfortable.¹⁶ These values apply to the rectum and it is likely that the less highly innervated colon is

less sensitive, indeed colonoscopists find that cutting biopsies from the rectum (at least near the anus) is painful while cutting samples from the colon is painless.

Some evidence for the insensitivity of the small bowel comes from studies by Accarino et al who stimulated the small bowel in awake human as part of a study into irritable bowel syndrome.¹⁷ They report that with transmucosal electrical nerve stimulation using 0.1 ms pulses at 15 Hz, patients tolerated 58 +/- 5 mA and healthy subjects tolerated 69 +/- 5 mA. In a similar study investigating the effects on motility¹⁸ the same group reported that “Electrical and mechanical stimuli induced dose-related perception; the perception and discomfort thresholds were 39 +/- 7 and 63 +/- 6 mA [0.1 ms pulses repeated at 15 Hz] and 31 +/- 3 and 49 +/- 5 ml for electrical and mechanical stimuli, respectively. More than one-half of electrical stimuli elicited clinical-type symptoms (abdominal pressure, fullness, colicky or sharp sensation) similar to those induced by mechanical stimuli; the remaining electrical stimuli (38 mA +/-10%) induced paresthesia or flutterlike sensation.” However care should be exercised in extrapolating from these results as the stimulation pulses were very much shorter than we used. (Incidentally, they found no adverse effect on slow wave propagation through the small bowel).

Finally, the following paragraph quoted from Ratani’s 1997 paper will serve as a cautionary conclusion to this section. “Electrical stimulation has been extensively used as a method to elicit contraction in strips of gut musculature *in vitro*. Direct smooth muscle stimulation has also been performed to improve emptying of ileal and colonic pouches in animals. A wide spectrum of electrical parameters is used in such preparations, and it would be misleading to extrapolate these parameters to humans. There have been no studies on electrical parameters required to induce colonic contraction by electrical stimulation in humans.” (Reference 11, page 1288).

6.3.1 Conclusion to the literature survey.

The overall conclusion to this survey is that, so far as we can find, there has been no previous publication describing an attempt to stimulate contractions of the small or large bowel so as to propel an object such as an endoscope. There have, however, been publications showing that electrical stimulation can be used repeatedly to produce

contractions of the smooth muscles of the gut. These publications suggest that it would be best to avoid short pulses of less than a few milliseconds since the effect of such neuro stimulations is very variable depending on the location and condition of the gut being excited. They also suggest that stray currents may cause undesired stimulation to other muscles in the neighbourhood.

6.4 Method - Description of the devices that were built



Figure 6.9 Devices for stimulating contractions of the colon. Device E1 is at 12 o'clock, Device E2 at 2 o'clock, etc.

Figure 6.9 is a photo of the five prototype electrical devices that were built.. It was decided at the outset to make the electrical devices bipolar (i.e. both electrodes on the device rather than having one electrode attached externally to the subject's skin) so that stray currents would be minimised.

It can be seen that the devices are variations on a theme and only the construction of the first electrical device (Device E1) will be described in detail. The reader may wish to

skip to the end of this section where a table briefly describes the principal features of the devices.

6.4.1 Device E1

Figure 6.10 is a drawing showing the principal dimensions for Device E1. The nose was made by turning a radius onto the end of a 20 mm diameter acrylic rod and the tail was then made by turning a taper onto the other end of the rod. A hole was also drilled into this end of the rod to provide a chamber.

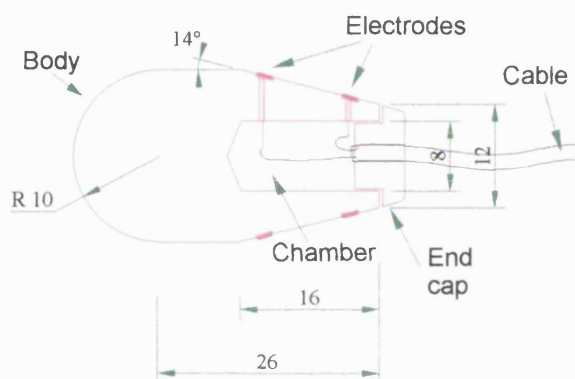


Figure 6.10 Device E1.

The angle of the taper was decided by making a number of tapers and propelling them along a length of colon by squeezing the outside of the colon between the thumb and forefinger. A taper of 1-in-2 (28° included angle) appeared to give a good compromise between ease of squeeze and speed of progress.

The two electrodes were made from lengths of 0.4 mm diameter stainless steel wire coiled round the tail of the device. These two coils, each of four turns, were located by two shallow grooves (0.2 mm deep x 2 mm wide) that were cut into the tail 10 mm apart and then wetted with cyanoacrylate “instant” adhesive. This adhesive served to hold the wires in place during assembly and then to seal the 0.6 mm diameter channels that connected the grooves to the chamber.

Finally, the cable was soldered onto the electrodes using orthophosphoric acid as a flux and an acrylic end cap was slid over the cable and sealed in place using Tensol 12 acrylic adhesive. It can be seen on the photograph that the chamber was packed with ‘Blue-tack’, this was to minimise the effect of the ingress of moisture into the chamber but in the event the seals worked better than expected and the chamber remained dry.

6.4.2 Devices E2 and E3

The design of the electrodes for Device E1 had been based on the misapprehension that electrical contact would have to be made with a ring of mucosa to make a ring of muscle contract. When it was realised that it was only necessary to make contact at two points, the design was altered and Devices 2 and 3 were made using stainless steel screw heads as electrodes. As well as making the Devices easier to construct, it was hoped that the concentration of current near the relatively small contact areas would help in stimulating the nerves and muscles in the thin walls of the bowels.

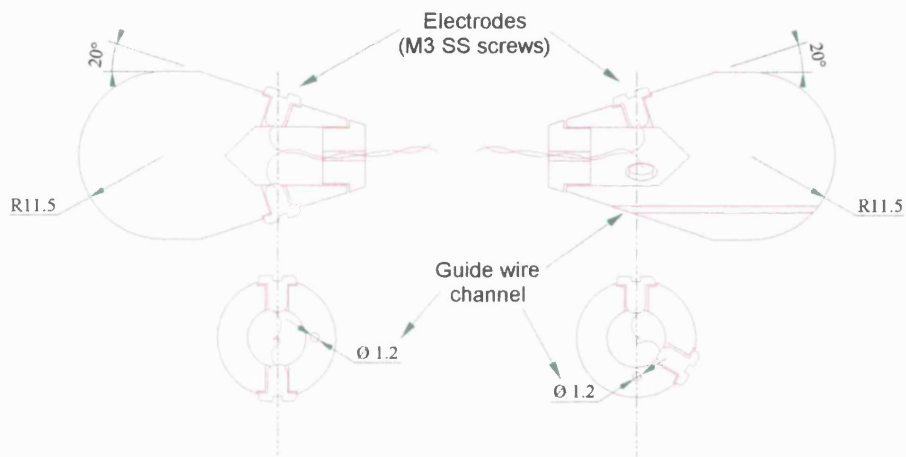


Figure 6.11 Devices E2 on the left and E3 on the right.

It was also decided to make the devices with a steeper taper (40° included angle rather than 28°) and to facilitate building the device the diameter was increased from 20 to 23 mm. A steeper taper was chosen because it meant that a weaker contraction of the muscle could propel the device forward and it was felt that at this stage it was best to concentrate on getting any movement and not worry about the speed with which the devices moved.

Figure 6.11 shows cross sections through Devices E2 and E3 and it can be seen that the only significant difference between them is the angle, and hence the spacing, between the screws. This was to allow us to test whether varying the length of the current path had a significant effect. It can also be seen that on Figure 6.9 that a small off axis hole has been

drilled longitudinally through each of the Devices. These were added as an afterthought to allow the electrode to be pushed into place over a standard endoscopic guide wire.

6.4.3 Devices E4 and E5

It was decided to start *in vivo* experimentation by trying to make the move along porcine oesophagus and to feed the electrodes into the animal through an endoscopic overtube (a semi-rigid rubber or plastic tube that fits over an endoscope and is used to lend rigidity to a length of GI tract). This meant that the diameter of the electrodes had to be reduced from 20 or 23 mm to 13 mm. Otherwise they are similar to Devices E2 and E3 and the only significant difference is that the electrodes for E5 were made as close together as was practicable so that the difference in current path lengths would be as large as possible.

The guide wire channels for these devices were not an afterthought and so were made on axis rather than off set. The reader may have noticed that the channel through Device E4 has an amber colour, this is because the tube that serves as a conduit for the guide wire is made from a length of amber polyimide tube (i.d. 1.7 mm, o.d. 1.8mm). Colourless acrylic tube was used for Device E5.

6.4.4 Summary of devices

Table 6.1 summarises the main features of the devices that were built.

Device	Diameter mm	Taper (Half angle)	Principal features
E1	20	14°	Electrodes formed from coils of SS wire
E2	23	20°	Electrodes were two SS screw heads 180° apart
E3	23	20°	Electrodes were two SS screw heads 120° apart
E4	13	20°	Small size to fit through overtube. Hole for guide wire. Electrodes 180° apart.
E5	13	20°	As E4, but electrodes as close together as possible

Table 6.1 Summary of the devices that were constructed.

6.5 Experimental Methods and Results

6.5.1 *In-vitro* experiments

The author wishes to express his thanks to Dr. Charles Hoyle of the Department of Anatomy and Developmental Biology at UCL for his advice and help during these experiments.

When this work started we did not have a Home Office licence to perform experiments on living animals, so we had to experiment of freshly excised porcine colon. This section describes what was intended to be the start of a series of *in-vitro* experiments, however the series was cut short when a licence for *in-vivo* work was granted. It will be seen that the results were inconsistent and to continue the series of experiments would have required considerable effort in improving the experimental technique.

The experiment consisted of removing colon from a freshly killed pig, placing it in a bath of warmed and oxygenated Kreb's solution, inserting Device E1 into one end of it and then turning on the stimulating current. The various steps in doing this will now be described.

The mini pig (weighing about 40 kg) was anaesthetised with Halothane and Enflurane and then, after it had been used for a different experiment, sacrificed by an injection of sodium pentobarbitol. Immediately after death, about a third of a metre of colon proximal to the rectum was excised and flushed for five to ten seconds with cold tap water before being placed in a tub of Kreb's solution and carried on a bicycle from the Royal London Hospital to UCL. Once at UCL the colon was drained and then placed in a dish of warm oxygenated Kreb's solution; it was ready for experimentation about 80 minutes after the death of the animal. The dish was filled from an oxygenated reservoir kept at 35° C but was not itself controlled and, regrettably, the temperature and oxygenation of the solution in the dish were not measured.

The recipe for the Modified Kreb's solution that was used was as follows;-Take 2 litres of water and add;-

15.6 g NaCl,

0.7 g KCl,

2.7 g Na HCO₃

2.8 g Glucose 0.2 g Na H₂PO₄ 0.3 g MgSO₄
2.5 ml of 1 molar CaCl.

100% oxygen was bubbled through the solution and occasionally, when the calcium chloride started to precipitate and the solution became cloudy, 5% CO₂ was added to the oxygen.

The electric current for the experiment was provided by a Grass SD9 stimulator, which is a signal generator widely used by physiologists. It provides an isolated output and allows the experimenter to adjust the output voltage, frequency, mark/space ratio and so on. Rather surprisingly the signal from the output amplifier is fed through a resistor to produce an output impedance of 1 k Ω , which is considerably greater than the resistance of the tissues and liquid between the electrodes. This means that most of the voltage set on the front panel is dropped across the output resistor and the set voltage serves only as a rough proxy for the output current in milli-amps. A battery powered voltage to current converter with a low output impedance was built to avoid this ambiguity but in the event it was not used, primarily because the physiologist felt more comfortable using the familiar Grass stimulator. An oscilloscope was connected across the output to monitor the voltage dropped across the electrodes and hence the current through the 1 k Ω resistor.

Device E1 was placed a few centimetres into the colon, the current switched on and various combinations of settings tried until one that worked was found. This successful setting used a 10 Hz repetition rate with an 'on' time of 25 ms and a unidirectional voltage (i.e. one electrode always positive with respect to the other) of 80 V, of which 75 V was dropped across the 1 k Ω output resistor, giving a current of 75 mA. No attempt was made to drain Krebs's solution out of the inside of the colon or to ensure a close contact between the electrodes and the mucosa, so it is likely that much of the current leaked through the Krebs's rather than passing into the colonic tissues. The success achieved with these settings was that on three occasions the colon was seen to contract and the device move slowly forward. In the excitement no measurements were made but the physiologist afterwards estimated that it moved about ten centimetres in thirty seconds while the author pessimistically estimated five centimetres in a minute. The

force required to pull the device back against the peristalsis was not measured but felt to be about 5 – 10 N.

This result was most encouraging in that it showed that the idea could work. However the conditions under which it did not work showed how ‘hit and miss’ the experiment had been. The experiment did not work when the direction of the device within the colon was reversed or when the device was placed in, or made its own way to, the other end of the piece of colon. Puzzlingly, it did not work when the polarity of the electrodes was reversed although it did work when we again reversed the polarity back to the original setting. Also it did not work when an attempt was made to repeat the experiment two hours later.

The next day another pig was being sacrificed at the Royal London Hospital and the experiment was repeated. This time the temperature and oxygenation of the bath containing the excised colon were controlled by using a peristaltic pump to circulate liquid between the bath and a heated and oxygenated reservoir. This time no success was achieved although the colon was shown to be viable by connecting the Grass stimulator directly to the colon with crocodile clips and producing contractions.

With the benefit of hindsight it seems that the most likely cause of the inconsistency was the poor and uncontrolled coupling between the electrodes and the colonic tissues, it would have been better to drain all the Krebs’s solution out of the lumen and suck the tissues down onto the electrodes. A rough attempt to do this was made at the time but only after the tissues had been subjected to various other attempts to improve matters and it is possible that they had become exhausted by then. At the time it felt that the key variable was that the experiment worked slowly when the physiologist was present and not at all when he was absent.

6.5.2 *In-vivo experiments*

Shortly after the experiments described above, Dr Swain received permission from the Home Office to perform a range of experiments on pigs including electrophysiological work. In view of the difficulty of preparing (i.e. evacuating) the pigs colon it was

decided to place the electrode in the upper GI tract, initially in the oesophagus and later in the duodenum just past the pylorus. There was some concern that stray electric currents around the oesophagus might affect the heart but the pig survived and, so far as we could tell from the pulse oximeter, the pulse pattern did not change at all.

During the first experiment an overtube was used to make a channel leading through the mouth and down into the oesophagus of the pig, which weighed about 35 kg and was anaesthetised with Enflurane. Device E4 (the small diameter device with electrodes 180° apart) was pushed with the tip of an endoscope through the overtube and a few centimetres down the oesophagus beyond the overtube. It could be seen through the endoscope that the oesophagus was stretched around the device and made good contact with the electrodes without the need for suction. The Grass stimulator was set to produce a 38 V unidirectional pulse at 10 Hz with an 18 ms 'on time'. As soon as the stimulating voltage was turned on Dr Swain could see a strong contraction and the rest of us saw the wires leading to the device being pulled rapidly into the pig's mouth at the rate of two or three centimetres per second. The device was allowed to proceed about 15 cm down the oesophagus before the current was switched off, the device was pulled back and the experiment repeated with the same results. This time the author saw the contraction and the contrast with the slow and feeble contractions during the *in-vitro* experiments was striking.

There were a number of experiments to be performed on the pig and time was very limited so no further work was carried out on the oesophagus. At the very end of the session Device E2 (large diameter with electrodes 180° apart) was placed in the pig's anus. With the same settings as before it produced an extremely sharp contraction and the current had immediately to be switched off. There was no obviously visible damage to the tissue, so the voltage was reduced from 38 V to 5 V and the Device reinserted. The voltage was then increased until at 15 V the anus twitched rapidly but did not advance the electrode. It was suspected that the failure to squeeze the Device forward was because the volume of muscle activated was too large so that the nose of the device was also enclosed in contracted muscle and there was not net force squeezing the device in either direction however no further tests could be performed as time had run out.

A fortnight later, using the same pig with the same preparation, the experiments in the oesophagus were repeated in a more systematic way. The results for various stimulator settings are shown below on table 6.2

Voltage set	5V	10V	20V	25V	30V	35V
Resulting movement	Nothing	Nothing	Slow contraction no movement	Contraction no movement	Contraction rapid movement	As for 30V

Table 6.2 The effect of varying voltage across the electrodes of Device E4 placed in pig oesophagus.

Increasing the set voltage from 30 to 35 V produced no benefit in terms of stronger or more rapid contractions, so it was decided not to test even higher voltages in case these produced fibrillations. Having settled on a 30V pulse the repetition rate was altered from 6 to 10 to 15 Hz and it was found that 6Hz produced slow and juddering progress, 10 Hz was faster but still showed a slight tremble while 15 Hz produced a fast and smooth movement. A brief test at 20 Hz showed no further improvement.

After the earlier experiments there had been concern that stimulating the oesophagus might simply have triggered the natural swallowing reaction. Also it was pointed out that in humans the top third of the oesophagus contains striated muscle and only the bottom third is entirely smooth muscle. It was therefore decided to repeat the experiment but this time the device was turned around and pushed tail first down the oesophagus until it was nearly at the stomach. When the voltage was turned on the device moved rapidly up the oesophagus towards the mouth.

An effort was then made to place the electrode just past the pylorus in the duodenum. Unfortunately there is a prohibition on using the same endoscopes on pigs and humans and the only endoscope available for use with animals was a gastroscope. This instrument was too short and it was not possible to place the device beyond the stomach endoscopically.

At the other end of the animal the waterjet driven endoscope was used, or “misused”, to flush faecal matter out of about 30 cm of the colon and rectum proximal to the anus. Device E2 was then placed a few centimetres beyond the rectum and the stimulating voltage was increased from 5 V. When the voltage reached about 12 V the right rear leg began to twitch violently although no contractions of the colon were visible and it was decided to abandon the experiment. In hindsight it is not surprising that this happened as the part of the colon, or rectum, containing the electrode was very close to the pelvic floor and would have been in intimate contact with the skeletal muscles that were twitching.

6.5.3 In-vivo, with surgical access to the small bowel.

Having failed to reach the small bowel endoscopically, it was decided to surgically open the abdomen and expose a length of small bowel. The pig was anaesthetised in the same way as before and electro-surgical diathermy was used to open a slit in the abdomen. It could be seen that the small bowel was inflated with a large amount of gas; the surgeon told us that this was due to the pig gulping in large volumes of air and anaesthetic as it struggled during the early stages of anaesthesia and that it was unlikely this would occur in humans. Nevertheless, gas in the gut is a potential problem for a system that depends on electrodes making contact with the bowel wall.

Two or three loops of small intestine were pulled out, placed on the outside surface of the abdomen and a hole was made in the intestine with a ‘purse string’ suture so that it could be opened and closed. The exposed loops were intermittently sprinkled with saline to keep them moist. Gas was allowed out of this hole and then Device E3 (the large device with electrodes 120° apart) was inserted. When the stimulator was set to deliver unidirectional 18 ms pulses at 15 Hz and 15 V the gut immediately began to contract and pull itself back over the electrode. The movement was quite rapid and the device made its way around 180° bend where the bowel folded back on itself. Also it was most encouraging to see that even where the bowel was resting on another loop the electrodes did not stimulate a contraction in that other loop. It should be remembered that the Grass stimulator has a 1 k Ω output impedance, so 15 V corresponds to about 15 mA.

Table 6.2 summarises the results that were found using the devices *in vivo* with various settings of the stimulator. The direction of the device in the bowel was reversed on a number of occasions and this made no difference to the rate of progress which shows that, as with the oesophagus, the simulated contraction is independent of the direction of natural peristalsis.

It is not easy to measure the speed of progress along a piece of bowel because the length of a given piece of living bowel varies with muscle tone. It was decided to minimise this problem by very gently stretching a piece of bowel and laying it roughly straight along the abdomen to make a 'standard' track which happened to be 18 cm long. Unfortunately this was only done after the first set of three results recorded in Table 6.3, so these have been marked with an asterisk * to show that the speeds should not be compared with later results.

The last 13 rows of Table 6.2 present results from a different pig on a different occasion. The electrode behaved reliably, in the sense that it always moved given sufficient stimulus, but was appreciably slower than had been seen previously. It may be that the speed of movement relates to the animal's response to the anaesthetic (Enflurane); it wouldn't breathe spontaneously and had to be mechanically ventilated and, towards the end of the experiments, its heart stopped for several minutes. (The timing of the heart attack did not relate to electrical stimulation of the exposed bowel).

It is encouraging that the electrodes appeared to do no harm. No damage was visible after the experiments and waves of natural peristalsis could be seen between runs, suggesting that gut motility still functioned. The pig that was recovered showed no ill effects.

It is worth commenting on a couple of other features of the later set of results. It can be seen that that brief pulses of 1.2 ms or less failed to produce progress, while pulses of 2 ms or longer were effective. This is not surprising as it is known that very short pulses stimulate the nerves, but not the muscles, and that nerve stimulation produces variable results depending on the exact parameters and the state of anaesthesia.

Also, it can be seen that no contraction was produced when the stimulator was set to deliver “bipolar” current (i.e. where each electrode is alternately positive and negative). This rather surprising result was confirmed what had been seen *in vitro*.

Variable	Constants	Speed mm/s
Repetition rate	Device E3, 15 V, 18 ms pulse width	
6 Hz stimulation	“	2.3*
10 Hz stimulation	“	3*
25 Hz. stimulation	“	2.6*
Pulse width	Device E3, 15 V, 15 Hz repetition rate	
15 ms pulses width	“	3.3
30 ms pulse width,	“	4.5
50 ms pulses width	“	4.0
Voltage	Device E3, 30 ms pulses , 15 Hz rep. Rate	
< 10 V	“	No contraction
12 V (≈12 mA)	“	4.3
20V (≈20 mA)	“	4.5
30 V (≈30 mA)	“	4.5
Device		
Device E1 (two wire coils)	No contraction at ‘standard 15 V’ setting and only weak contractions at 40V. Presumably caused by the large area electrodes giving a low current density.	
Device E2 (large with 180° electrode separation).	15 V, 30 ms pulses ,15 Hz rep rate 20V, 30 ms pulses ,15 Hz rep rate 20V, 50 ms pulses ,15 Hz rep rate	3.0 4.0 3.3
Device E5 (small with electrodes close together)	No contraction even at 30 V. This was ascribed to problems making contact with the walls because the device was too small for the lumen, but in hindsight the relevance of the electrodes being close together should have been investigated further	
Device E4 (small with electrodes 180° apart)	25 V, 30 ms pulses ,15 Hz rep. rate Produced contractions but only moved slowly. The bowel had to contract a long way before it began to squeeze the small device, so most of the contraction was wasted	< 1.0

Different pig	All tests with E3	
	First 3 runs of 25 cm each. 25 V, 17 Hz, 15 ms	1.0 – 1.5
“Bipolar” (i.e. AC)	20 V, 20 Hz, 10 ms	No contraction
2 ms at 17 Hz	20 V.	0.6
2 ms at 120 Hz	20 V	1.0
0.4 ms		
0.6 ms	120 Hz, 20 V	Barely perceptible
0.8 ms	120 Hz, 20 V	0
1.2 ms	120 Hz, 20 V	Barely perceptible
2.0 ms	120 Hz, 20 V	1.0
40 V, 100 Hz, 0.1 ms	Settings used by Malagalada et al ¹⁷	0
60 V, 100 Hz, 1 ms	“	0

* Different method of estimating speed – see text above.

Table 6.3 Summary of the speed at which the devices progressed along the bowel of a live pig with various settings of the Grass stimulator. (The stimulator has 1 k Ω output resistance, so 1 V set \approx 1 mA).

6.5.4 *In-vivo, with surgical access to the large bowel.*

The slit in the pig’s abdomen was extended, a length of colon near the caecum was exposed and a small incision made through which the electrode was inserted. The diameter of the colon at this point was between five and seven centimetres and even the larger device seemed small in relation to the colon.

With the stimulator set to 15 V, 15 Hz and 30 ms the colon immediately started to contract, however the rate of contraction was very much slower than in the small bowel and a longer section of bowel was contracted so that the device became encased in contracted muscle and no progress was possible. It appeared that a longer device might have worked.

With the gut exposed on the outside surface of the abdomen, it was possible to see natural waves of peristalsis moving around the small and large bowels. The waves in the small intestine moved much more rapidly and with a more sharply defined front than

those in the colon, which is not surprising considering that food passes through the small bowel in about one and a half hours compared with the days it can take to pass through colon (though scintigraphy studies have shown that the colon can move matter from the caecum to the sigmoid in less than one minute¹⁹). It may be that this accounts for the difference in the rate at which the muscles respond to electrical stimulation, though caution should be exercised in drawing conclusions from such tentative data.

6.6 Conclusions

At the start of the work on using active stimulation of the smooth muscles to propel devices along the bowel, it was felt this approach fell into the “interesting” rather than the “realistic” category. However the results, though very preliminary, were better than expected.

A particularly attractive feature of this approach is that it might greatly facilitate enteroscopy, - the inspection of the small bowel. The small bowel is the area in the gastrointestinal tract which is most inaccessible to endoscopy;²⁰ either the endoscopist must push an endoscope from the caecum or the duodenum or he must slowly allow natural peristalsis to pull a long and extremely flexible Sonde type enteroscope down through the digestive tract so that he can observe the walls of the small bowel as he pulls the enteroscope back. None of these approaches is satisfactory; technical difficulties with pushing only allow the ends of the small bowel to be investigated while the long time, several hours, required to pass a Sonde type enteroscope makes the procedure most unpleasant and impracticable. Any device that could carry a small camera and light source rapidly through the small bowel would be a considerable benefit.

Electrical stimulation has been used repeatedly to drive devices in both directions around the small bowel and the oesophagus and to produce contractions in the large bowel. The speed of progress in the small bowel (about 4 mm/s) was rapid compared with Sonde type endoscopy and there appeared to be no tendency for neighbouring loops of bowel to be stimulated. The currents required are small, particularly considering that the animals were anaesthetised, and it is reasonable to hope that they will not cause unacceptable pain. Also, the animals showed no evidence that their digestion had been upset by the stimulation although it should be remembered that colon is sometimes said to be an

unforgiving organ in that peristalsis patterns can become upset and not re-establish themselves.

One problem is that small devices that could easily be swallowed did not work well and it appears that a diameter of about 20 mm will be required. In principle this problem could be overcome by incorporating a mechanism or balloon within the device that allowed it to be expanded once inside the bowel.

So far as the large bowel is concerned it is too early to draw any conclusions. Even if the colon does contract slowly it does not mean that the system is of no use. After all, existing colonoscopy only advances at an average speed of about 1 - 2 mm/s and even that requires great skill. If the device was optimised for the colon with respect to length, diameter and angle of taper then it might be that the speed and, particularly, the ease of the procedure could be improved.

At the time of writing, the project to navigate the bowel by stimulating contractions is at a frustrating stage; preliminary results look very encouraging but practical difficulties with reaching the duodenum at one end or emptying the colon at the other end are frustrating further investigations. What is apparent is that, as currently envisaged, the physics and bioengineering involved are relatively straightforward and the difficulties arise around physiology and medicine. It is hoped that the investigations will be taken forward in a more clinical setting perhaps as part of an MD project.

7 The use of a lubricating sleeve to facilitate pushing a colonoscope along the bowel.

Three of the four approaches investigated in this thesis are concerned with providing traction at the tip of the endoscope. However there would be no need for traction if there was no friction between the shaft of the endoscope and the walls of the colon. In this case the endoscope could be pushed smoothly along the colon without dragging on the walls and forming loops, at least so long as the endoscopist took care to steer the instrument so that he was always pushing into open lumen rather than into the wall. Whilst frictionless sliding is not possible, substances called 'hydrogels' have been developed that reduce the coefficient of friction to extremely low values. Uyama et al report that "the surfaces of EVA and PVC tubes grafted with DMAA [a hydrogel] were found to exhibit frictional forces around 0.5 N against a PVC and a silicone surface under wet conditions, whereas the frictional force of the ungrafted tubes against the same substrates was 10 and 20 N for PVC and EVA, respectively."¹

This chapter looks at the practicality of using a 'lubricious' hydrogel coating to reduce friction and whether the reduction achieved actually aids in inserting the colonoscope.

7.1 Introduction - Hydrogels

LaPorte defines hydrogel as a term "used to describe materials that are hydrophilic in nature and exhibit the characteristic macromolecular structure of a gel. A gel is best described as a continuous three dimensional network that is held together by chemical or physical bonds. Sufficient interstitial space exists within the network, and solvent molecules (in this case water) can become trapped and immobilised, filling the available free volume."²

The ability to hold large amounts of water gives hydrogels many of the properties that make them commercially attractive. In terms of tonnage much their biggest application is as an absorbent in babies' nappies, whilst the main medical application is for contact lenses where the high oxygen permeability that results from the mobility of the water is a

desirable feature. From our point of view the important property is that water trapped at the surface of a hydrogel acts as a lubricant; “the slipperiness of the hydrated surface is due to the high water content of the hydrated layer. Quick squeezing out of water from the grafted hydrogel layer by low pressure gives us a feeling of slipperiness.”³ A wet hydrogel coated rod feels like an eel.

At a molecular level most hydrogel polymers contain carbon atoms held together primarily by single covalent bonds in the main chain and this allows for fairly unrestricted rotation of chain segments about the bonds, making the molecules extremely flexible⁴. These hydrogel molecules are usually bonded to a substrate in one of two ways, both illustrated in Figure 7.1 (adapted from Conroy⁵).

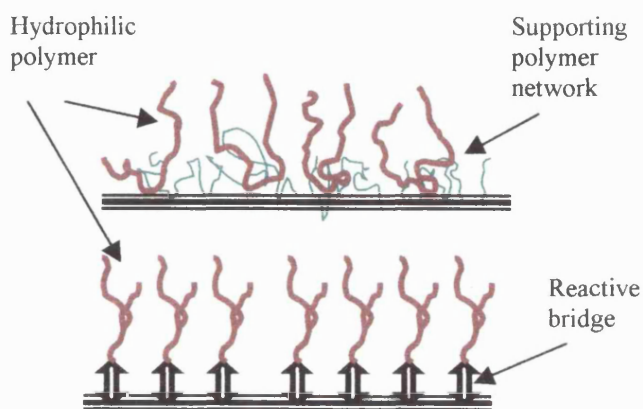


Figure 7.1 Methods of attaching Hydrophilic polymers to hydrophobic substrates. An interpenetrating network (above) and grafting (below).

One approach is to tangle the long hydrophilic molecules into the surface of a polymer so that they are literally anchored in the substrate. This tangled web is called an ‘interpenetrating network’ (IPN) and is used for many commercially available lubricious coatings. An alternative approach is to graft one end of the hydrophilic polymer to the substrate using a reactive molecule as a bridge between the two⁶. Whichever technique is used the end result is that the surface is covered in long and extremely flexible hydrophilic molecules. Looking at Figure 7.2 (adapted from

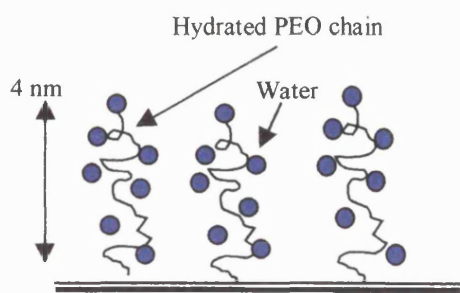


Figure 7.2. “Molecular cilia” provide lubrication

Nagaoka⁷) it is possible to imagine why these “molecular cilia” would make a slippery surface providing something like the squeeze film of hydrodynamic lubrication.

Many workers have measured the coefficient of friction between hydrogels and other surfaces in vitro and they usually show very

low values in the range of 0.05 to 0.1^{8,9}. The ability of the hydrogel to hold water without letting it squeeze away makes it particularly suitable for combating “stiction”; i.e. the friction that arises between two surfaces that are stationary with respect to each other.

Despite searching, only two articles have been found investigating the frictional properties of hydrogels in vivo and they suggest that while hydrogels are better the improvement is not as much as some of the in vitro work would suggest. Neither article measures the coefficient of friction but instead they compare the forces required to move various catheters or tubes along a rabbit’s urethra. The earlier paper¹⁰ (1987) uses a mechanical device to pull three different types of commercially available catheter out of the urethra. It concludes that Biocath hydrophilic catheters required 74% of the force needed for silicone rubber catheters (both supplied by C. R. Bard, Murray Hill NJ, USA) which in turn only required 42% of the force needed for latex catheters (Narco Biosystems, Houston, TX, USA).

The more recent paper¹¹ (1994) describes a reciprocating mechanism that moves a stainless steel tube up and down the urethra and compares the forces required when the tube is lubricated with olive oil prior to insertion with the forces required when the tube is covered by a fluorocarbon ‘heat-shrink’ tube onto which hydrogel (*N,N*-dimethyl acrylamide) has been grafted. Their results are reproduced as Figure

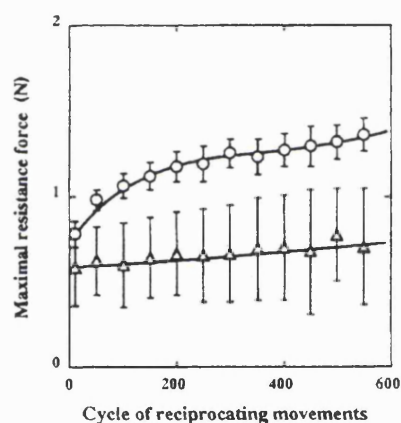


Figure 7.3 Change in maximal resistance force for a steel tube dipped in olive oil (o) or coated with hydrogel (Δ). Bars show standard deviations. From Tomita et al.

7.3 where it can be seen that the oil rapidly rubs off the steel and becomes less effective while the hydrogel stays in place and continues to act as a lubricant.

As might be expected, results from commercial suppliers of lubricious coatings show very encouraging results and Figure 7.4 and 7.5 reproduce two of these. To some extent these results may reflect improvements in the technology over the last few years but it is hard to judge them as they give no details of how the measurements were made; indeed it is not clear what units are used in the Slip-Coat tests.

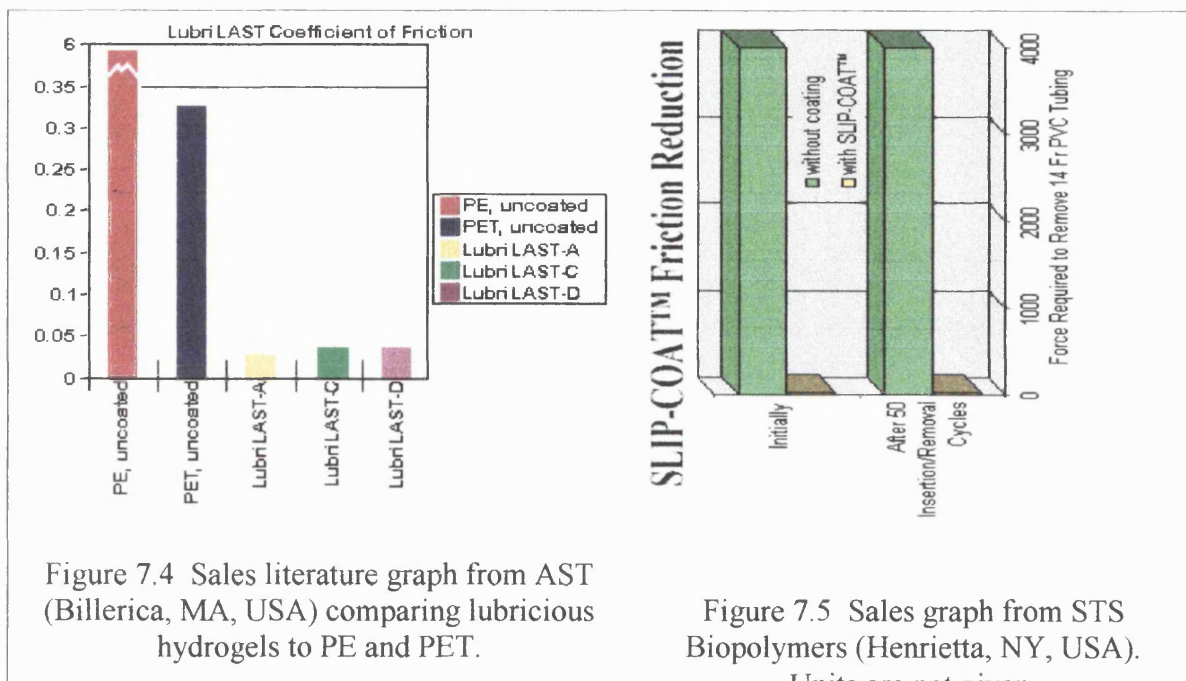


Figure 7.4 Sales literature graph from AST (Billerica, MA, USA) comparing lubricious hydrogels to PE and PET.

Figure 7.5 Sales graph from STS Biopolymers (Henrietta, NY, USA). Units are not given.

7.1.1 The proposed hydrogel coated disposable sleeve for an endoscope.

Hydrogels are not suited to reusable medical equipment. They are fragile when wet and would tend to retain chemicals from the disinfectants, such as glutaraldehyde, used to sterilise endoscopes between patients. A possible solution to this problem is to make a disposable sleeve that has a hydrogel surface and can be slid over the endoscope before use. A further advantage of a sleeve is that it could be used with existing endoscopes without the need for any modifications. A disposable sleeve need not be expensive, - in answer to our enquiry Applied Surface Technologies (AST, Billerica, MA, USA) estimated the cost of coating a polyurethane sleeve as \$1.50 to \$2.50 in ten thousand off quantities.

Disposable sheaths for endoscopes have been developed as consumables to allow an endoscope to be used on many patients without the need for chemical sterilisation^{12,13}. Sterilisation with liquids such as glutaraldehyde is time consuming, can produce allergic reactions and is, at least theoretically, not completely effective. At least one company (Vision Sciences Inc of Natick Massachusetts, USA) sell an ‘Endosheath system’ and such systems have been favourably reviewed^{14,15,16}.

The idea of adding a lubricious coating to one of these sheaths seems obvious and it is hard to believe that hydrogel coated sheaths have not been tested. However searches of the academic and patent literature (Medline, BIDS and the IBM Patent Miner) have failed to reveal anything except a passing mention by Tomita et al (reference 11 above) to the possibility of coating endoscopes with hydrogels. The professor leading this work (Ikada) was contacted by e-mail with a request for more details and, after a long delay, he forwarded the mail to Tomita who, after another long delay, sent a minimal reply saying that results had been “adequate” but that the commercial sponsor had decided not to proceed. It was not clear whether they had used a sheath or coated the shaft of an endoscope or, indeed, whether they had ever built and tested any instrument.

Professor Tighe¹⁷ of Aston University and Professor Williams of Liverpool University, both of whom are eminent in the world of hydrogels though not in endoscopy, were contacted and neither of them knew of hydrogels being used to lubricate colonoscopes. Similarly endoscopists including Dr Saunders Senior Lecturer at the MRC Endoscopy Unit at St. Marks Hospital, Professor Bell of Sunderland Royal Hospital and, of course, Dr Swain had not heard of this application.

STS Biopolymers (Henrietta, NY, USA) were contacted by e-mail and asked whether they knew of anyone having carried out tests with lubricious sheaths for endoscopes. One of their directors (Dr R Goodwin) replied “that it is safe to say the idea had been discussed” but that he was not aware of anyone actually testing it.

Despite the suspicion that there was undiscovered prior art, it was decided to press ahead and produce a disposable lubricious sheath or sleeve that might improve the method of advancing a colonoscope along the colon. It was decided to carry out a preliminary study comparing the frictional properties of a commercial endoscope with those of commercially available, hydrogel coated, urinary catheters.

7.2 The frictional properties of an endoscope shaft compared with those of hydrogel coated catheters.

This section could almost stand as a short chapter in its own right. It describes a series of experiments that were designed to establish whether there was likely to be a significant benefit to endoscopy from using hydrogels. The section starts with a brief description of what the coefficient of friction is and of how it can be measured, before going on to list the experiments performed, the results from the experiments and the conclusions that can be drawn from them.

The coefficient of friction (μ) is dimensionless and is defined by the ratio $\mu \equiv \frac{F}{N}$,

where F = Force parallel to two sliding surfaces pulling or pushing them past each other,
 N = Force Normal to the surfaces pressing them together.

' μ ' depends on the relationship between two surfaces and does not depend on either of the surfaces alone; it is not possible to look up, for example, μ for steel and μ for copper and thereby find the coefficient of friction for steel sliding on copper. It is necessary to measure steel-on-copper, or at least find a reference to someone who has. Furthermore, it is a notoriously difficult measurement to make reliably because it depends on surfaces and surface finish and surface cleanliness/lubrication are prone to vary.

For an ideal substance μ is independent of the speed at which the two surfaces slide across each other. For almost all real materials there is a velocity dependence and, in particular, the force required to start stationary surfaces sliding is greater than that required to keep them moving; the static coefficient of friction (μ_s) is greater than the dynamic coefficient of friction (μ_d). This difference is particularly large where sliding is facilitated by liquid between the surfaces but where the liquid may be squeezed out from between the surfaces when they are stationary. The high value of μ at start-up with "hydrodynamically" lubricated journal bearings causes serious problems in engineering applications and systems have been developed that actively pump oil into the base of the

bearing or, alternatively, use materials and surface preparations some of which retain a small amount of oil to provide a “boundary lubricant layer”.

The contrast between dynamic and static friction can be seen when pushing endoscopes along models using excised colon. If the endoscope becomes stuck in a loop of tissue so that the two are pushed together without moving then they appear to become stuck together. Since it is precisely these *stuck* occasions that are of interest, it was decided to measure the static coefficient of friction (μ_s) between colonic tissues and endoscope materials although measurements of (μ_s) are particularly distrusted by tribologists.

It was not clear how relevant the published results are to the situation encountered in colonoscopy. Manufacturers such as Olympus use proprietary and secret lacquers on their endoscopes to minimise friction. Also the lining of the colon produces mucous which is slimy and may make it different to other tissues. Indeed if the colon is as slippery as a hydrogel coated surface then the possibility for gain by coating the endoscope with a hydrogel would be extremely limited.

Ideally the measurements would have been made in-vivo but this was not practicable and freshly excised porcine colon was used instead. The procedure for collecting the colon will now be described, partly for completeness and partly because this aspect of the work loomed very much larger than the author had anticipated. The pigs were being used for a completely unrelated surgical experiments which ended with the pigs being killed with an overdose of barbiturates. The surgeons would then excise some tissues and leave the carcass for the present author to pick over. The stomach was then opened and the colon removed along with the surrounding sack and the mesenteries which, in the pig, tightly constrain the colon into a kind of tight bundle that contains several loops. Cutting the colon free from this bundle had to be done carefully to avoid puncturing the colon. The contents of the colon were manually extruded, which sometimes involved pouring a small amount of water (say about 300 ml) into the lumen to free up the faeces. The inside of the colon was then washed by filling it once only with tap water and after a few seconds letting the water flow out. Finally, the excised colon was carried to the Medical Physics Department a couple of streets away and mounted onto one of the rigs described

below for testing. The time between death and the first measurement was about seventy minutes.

Some of the colon was set aside and frozen for later use in models for testing methods of colonoscopy. Friction measurements were made with defrosted colon to validate that stored colon had similar frictional properties to fresh colon.

7.2.1 Methods for finding coefficients of friction.

As was stated earlier, the coefficient of friction is defined as ' $\mu \equiv F/N$ ' where 'F' is the force parallel to two sliding surfaces pulling or pushing them past each other and 'N' is the force normal to the surfaces pressing them together. It follows from this definition that the tangent of the angle at which a weight slips on

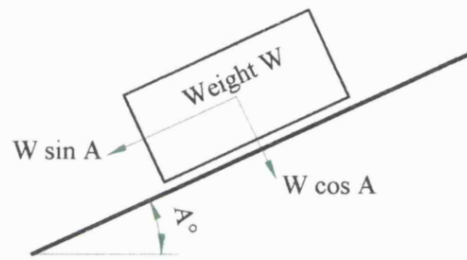


Figure 7.6 A weight on a surface.

an inclined surface is equal to the coefficient of friction. This can be seen by applying simple geometry to Figure 7.6 where the force trying to slide the weight (F) is the component of the weight parallel to the surface while the normal force (N) is the component of the weight normal to the surface; i.e.~

$$\mu \equiv \frac{F}{N} = \frac{W \sin A}{W \cos A} = \tan A \quad (\text{Eq 7.2})$$

The jigs that were used to find the coefficients of friction relied on this relationship. In essence they consist of a toboggan that has excised colon stretched over its runners so that it can slide freely along rails made from the other material being investigated. The rails are then tilted and the angle is measured at which the toboggan starts to slide (μ_s) or, once pushed, continues to slide (μ_d).

Although the static coefficient (μ_s) is notoriously variable most effort was put into measuring this because, as has been mentioned above, it is the relevant coefficient for a

situation where the endoscope has become stuck. The dynamic coefficient of friction (μ_d) was found by tilting the table a known amount and then giving the toboggan a small push to get it started, the angle was then increased or decreased until the angle at which the toboggan just kept moving was established. This somewhat arbitrary procedure gave reasonably consistent results.

The rigs were essentially the same except that when measuring the coefficients between tissues and an endoscope the rails consisted of the shaft and umbilicus of an endoscope whereas the measurements of the coefficients between tissues and hydrogel coated surfaces used commercially available hydrogel coated urinary catheters as the rails because it was not practicable to coat an endoscope.

7.2.1.1 Rig for measuring friction between tissues and an endoscope.

The rig drawn in Figure 7.7 was built so that the coefficient of friction between excised colon and an endoscope could be measured. Grooves were cut into a piece of wood so that the shaft and umbilicus of an endoscope (Olympus CF 1TI) could be laid into them to form two rails. A toboggan was made by clamping a length of colon around a piece of acrylic that had shallow channels milled into it, as illustrated. The colon was mounted so that the mucosa were against the rails which were frequently wetted to simulate in-vivo colon. The toboggan was then placed on the “rails” so that it could slide freely along them

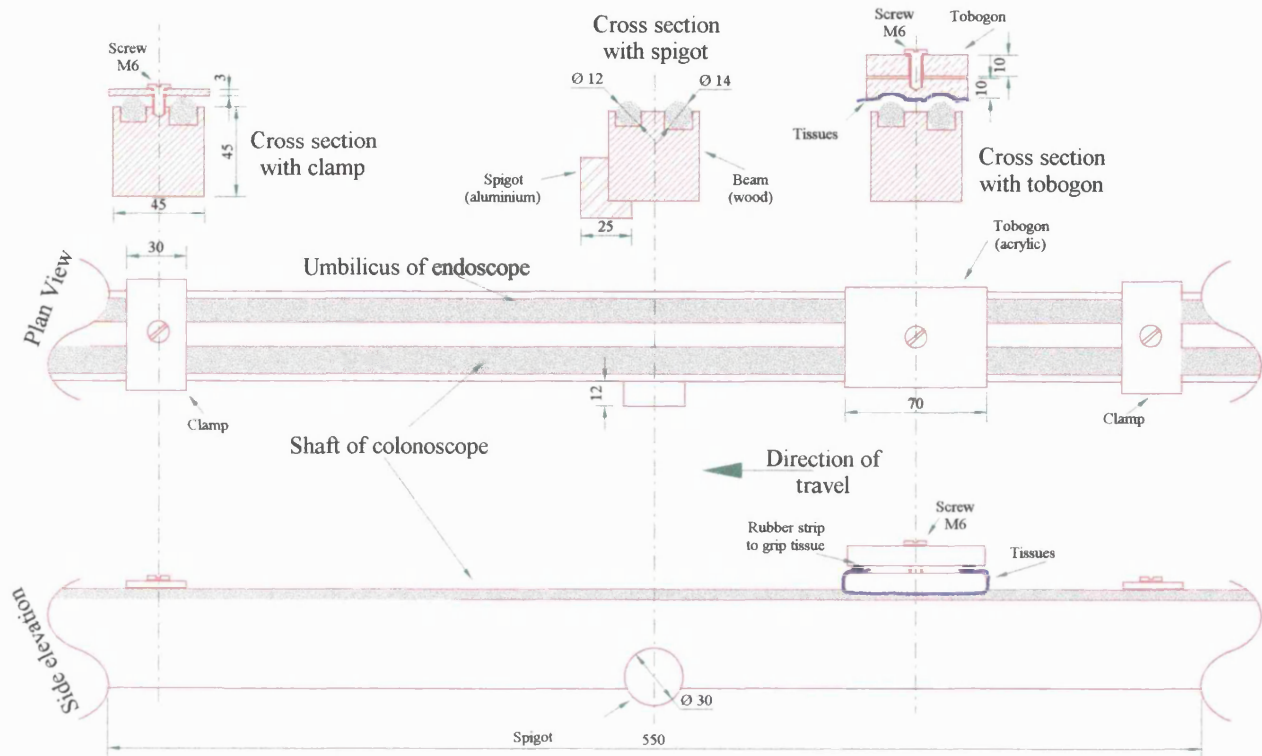


Figure 7.7 The rig and the toboggan used to measure the coefficient of friction between an endoscope and excised colon.

About half way along the piece of wood was a spigot that could be held in the chuck of a numerically controlled rotary table so that the rails could be slowly and smoothly tilted (usually at $1^\circ/\text{sec}$) until the toboggan started to slide. The Haas S5C control unit for the CNC rotary table displays the angle in degrees to 3 decimal places, which gives a spurious sense of accuracy to the experiment. The rotary table was zeroed using a precision spirit level on the wooden bar and this was checked by measuring the height of either end from the floor which, being cast concrete, was assumed level. Later when hydrogels were used and small angles had to be measured, the slip was measured with clockwise and anticlockwise tilt. Reassuringly, it was more or less the same in either direction.

With ideal materials the coefficient of friction is independent of the pressure between the surfaces but in practice where surfaces conform to each other this may not be the case and an appropriate pressure had to be chosen for these experiments. It will be

remembered that Chapter 3 described in vivo force measurements made during colonoscopies and showed typical pushing forces of 5 – 10 N. However these measurements gave no indication of the contact area between the endoscope and the colon and so no conclusions could be drawn about the pressures applied. For want of anything better a plausible guess was made and the contact length and width were taken as 0.5 m and 0.01 m, which gave a pressure range of 1 – 2 kPa.

The contact area between the tissue on the toboggan and the endoscope was judged by looking at the tissues through the transparent acrylic toboggan when it was resting on the endoscope rails. Where the tissue touched the endoscope the change in reflectivity could clearly be seen. For each rail the contact area was 8 – 10 mm wide by 70 mm long, so the total area was about 12 to 13 cm² (1.2 to 1.3 x 10⁻³ m²). The toboggan weighed 1.2 N, so the contact pressure with the toboggan unloaded was about 1 kPa. The load and pressure could be increased by placing weights on the back of the toboggan and an extra 1.2 N was sometimes added to increase the pressure to about 2 kPa.

7.2.1.2 Rig for measuring friction between tissues and a hydrogel coated catheter.

It was impractical to apply a lubricious hydrogel coating to an endoscope so, instead, the coefficient of friction of porcine colon was measured against commercially coated urinary catheters (Astra Lofric, size 16, OD = 5.3 mm). The test rig, shown in Figure 7.8, was similar to that used for the endoscope except that it was smaller and made from aluminium and rather than laying the catheters into channels they were kept straight by sliding 3 mm diameter silver steel rods into their lumens. The toboggan was the same one used in the previous experiments.

At the time this work was carried out no fresh porcine colon was available from UCL, the Royal London or the Royal Veterinary College. Defrosted colon was therefore used.

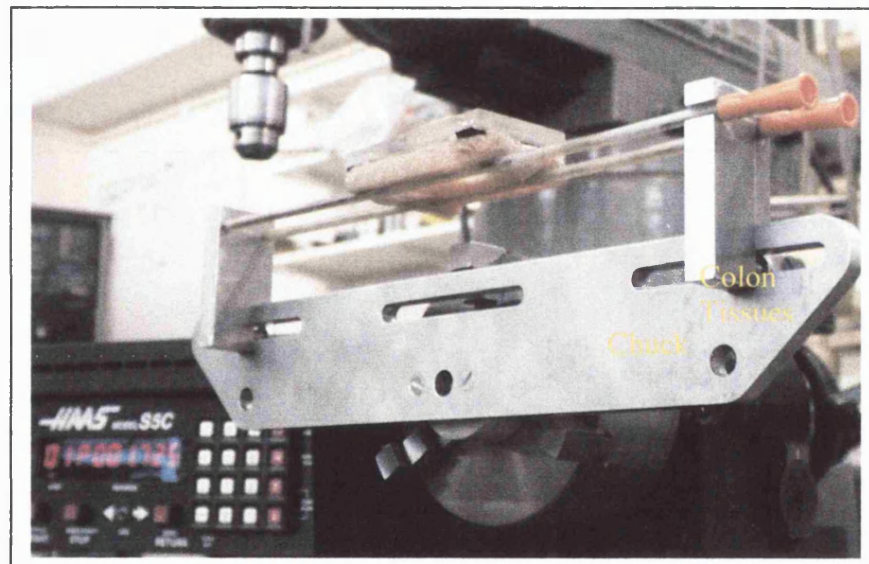
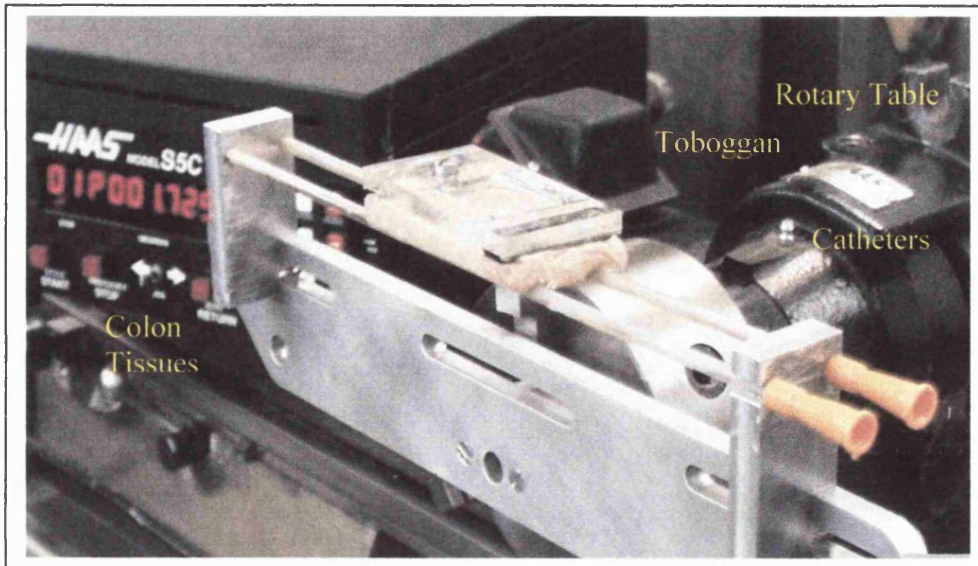


Figure 7.8 The toboggan, with tissue clamped onto it, rests on rails made from hydrogel coated catheters with steel rods running through them.

(Note the chuck of the rotary table that grips the central spigot of the jig.)

The catheters were coated with water before each run and it could immediately be felt that the toboggan slid very freely. This meant that smaller angles had to be measured and more care had to be taken to avoid errors in leveling, or ‘zeroing’, the table and recording at what

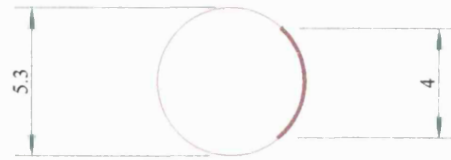


Figure 7.9 Portion of the catheter in contact with tissue.

angle sliding started. To achieve this, the table was rotated very slowly at $\frac{1}{4}^\circ$ per second and the results were repeated with clockwise (+) and anticlockwise (-) rotation. As with the endoscope the contact area could be seen through the back of the toboggan. After the first two experiments had been performed the projected width of the contact area was measured and found to be about 4 mm. Which, as is illustrated in Figure 7.9, corresponds to an arc length of about 5mm. The contact area for two rails is therefore $2 \times 70 \times 5 = 700 \text{ mm}^2 = 7 \text{ cm}^2$ ($0.7 \times 10^{-3} \text{ m}^2$).

From above (section 7.2.1.1) it can be seen that this is about half the area of contact observed with the endoscope. The rail system was therefore modified so that it had four catheters and consequently about the same contact area as the endoscope. The toboggan was also modified to run on four rails. During the experiment the middle two rails could be removed so that any dependence of the coefficient of friction on contact area could be seen and the results are presented as Test 7 in Figures 7.10 and 7.11.

7.2.2 Experiments and results.

The results for the static coefficient of friction are presented in Figure 7.10 and those for the dynamic coefficient in Figure 7.11. The results are presented in chronological order with each experiment (‘test’) being on a different day. The toboggan weighed 1.2 N and, unless otherwise stated, the results are for the toboggan without any extra weights added. It will be remembered that this corresponds to a contact pressure of about 1 kPa.

Before each run the tissues were sprinkled with water and then placed on the rails and allowed to stand for about 30 seconds before the rails were tilted. This was to prevent the tissues drying out while allowing time for the excess water to drain off.

Test	Coefficient Between	Fresh/defrosted	Comments
1	Endoscope/colon	Defrosted	Shows that the small extra weight makes no difference
2	“	Fresh (70 min. post mortem)	The shift in the coefficient of friction during the first three runs appeared to be genuine. It is suspected that this related to the tissues ‘bedding in’ so that the contact area increased but, unfortunately, this was not measured at the time. [The author’s excuse for the poor experimental technique is that he was flustered; on previous occasions clinicians had excised the colon but this time he was left alone in the room with a pair of scissors, a scalpel and a dead pig].
3	“	Fresh (75 min. post mortem)	Repeat of Test 2. Note that as before the addition of a 1.2 N weight appears to lower the static coefficient of friction.
4	“	Defrosted	Runs 1 – 6 are a repeat of Tests 2 & 3 but with defrosted colon.
4.a	“	“	Endoscopists frequently smear KY Jelly (Johnson and Johnson, Slough, UK) onto the tip of the endoscope before pushing through the anal sphincter. To study the effect of this the endoscope rails were smeared with KY Jelly before each run. This made them feel very slippery to the dry finger but it could immediately be seen that it did not help in the same way with the wet tissues of the toboggan. The toboggan moved very slowly, as though it was dragging through a viscous fluid. This tendency to creep very slowly made it impracticable to measure the static coefficient of friction (hence no results on Figure 7.10) and even the values for dynamic friction (Figure 7.11) are very approximate.
4b	“	“	Culinary fat such as “Spry” are sometimes used to lubricate the endoscope, particularly when the endoscope is being pushed through an overtube. Coefficients of friction were measured with a commercial mineral oil (“3 in 1”) and then with lard (Tesco) smeared over the endoscope. The oil was dabbed off the colon using tissue. The effect of the oil was similar to KY Jelly, with the toboggan moving so slowly that it was hard to tell whether it was moving at all.
5	Catheter/colon	“	Two rails made from hydrogel coated urinary catheters.
6	“	“	Repeat of Test 5
7	“	“	The first six runs were with two “rails”, while four “rails” were used for the final six runs

Table 7.1 Experiments with tissues sliding against an endoscope or a hydrogel coated catheters

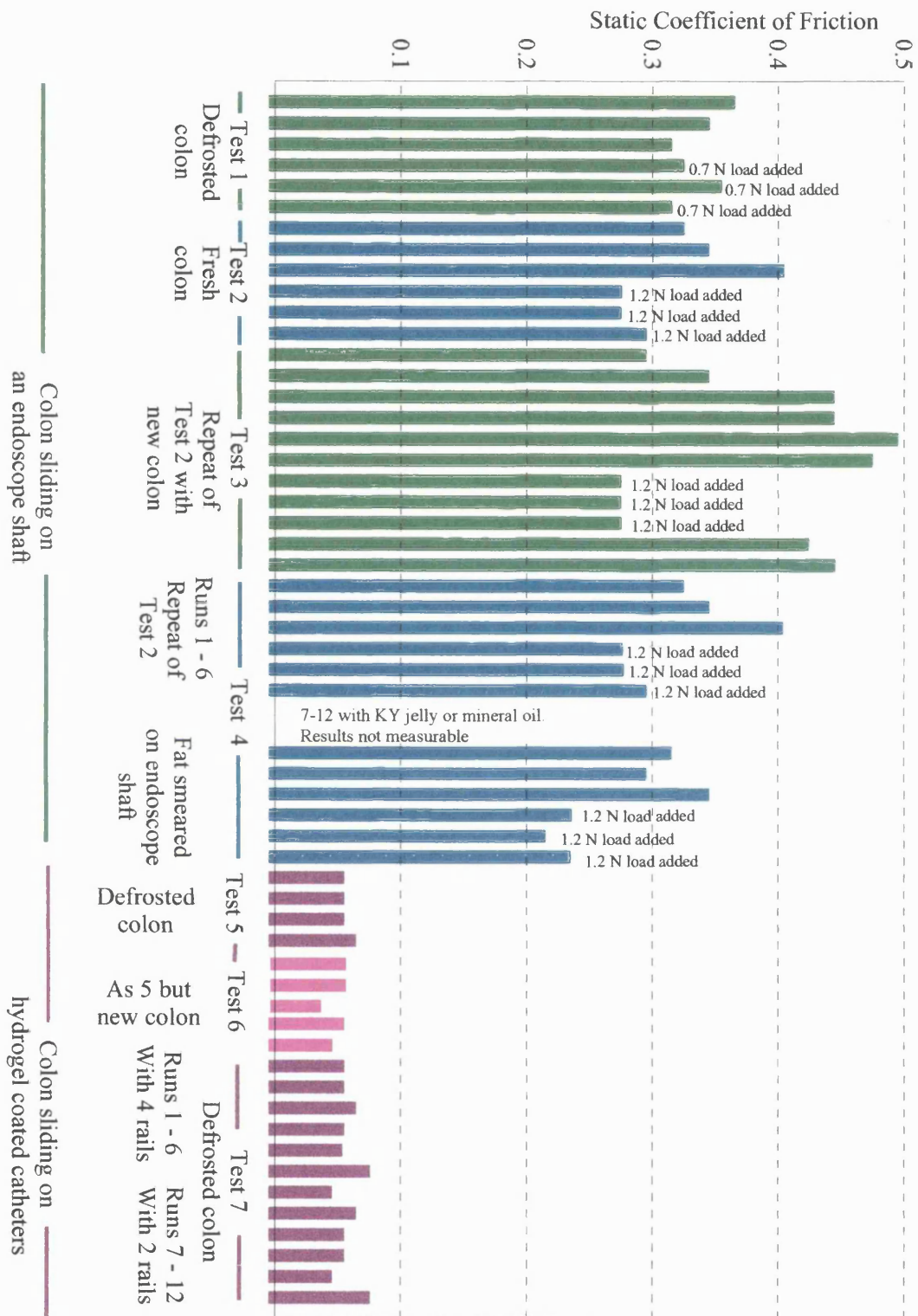


Figure 7.10 Measurements of the static coefficient of friction between excised porcine colon and an endoscope or hydrogel coated catheter.

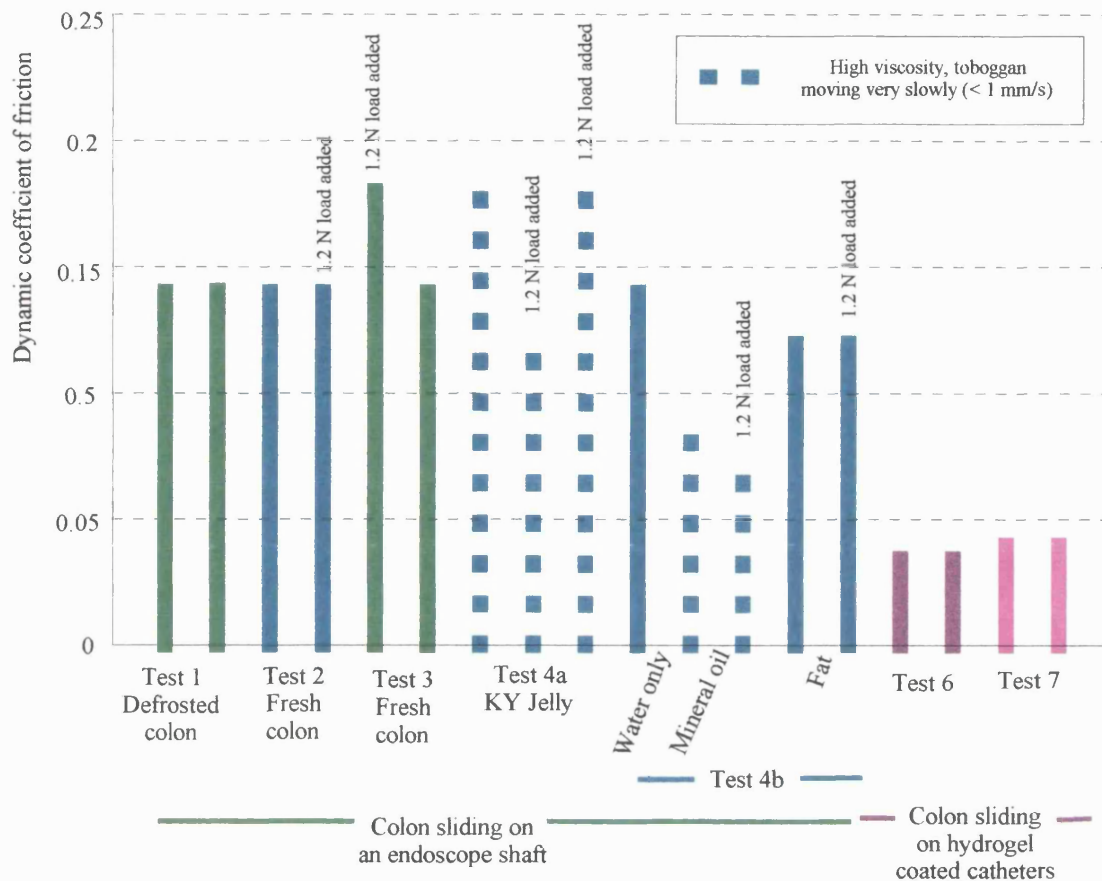


Figure 7.11 Measurements of the dynamic coefficient of friction between excised porcine colon and an endoscope or hydrogel coated catheter.

7.2.3 Discussion of the results

The outstanding feature of these results is that friction is very considerably reduced by using a lubricious hydrogel coating. This was confirmed when the toboggan was pushed by hand and it could immediately be felt that when sliding on the ‘Lofric’ catheters it moved freely regardless of speed or load.

It was stated earlier that tribologists prefer to measure the dynamic coefficient (μ_d) rather than the static coefficient (μ_s) and, indeed, comparing Figures 7.10 and 7.11 it is clear that the dynamic results are more consistent than those for the static coefficient.

There is no obvious explanation for the variations between similar experiments, but it is possible to speculate on the reasons. One factor that varied between runs was the thickness and feel of the colon tissues; in some places they are two or three millimetres thick and feel muscular, while in other places they are no more than sausage skins. Some variation between runs may also have been caused by factors such as the room temperature (which unfortunately was not recorded) and the amount of water spread on the 'rails'. In view of these caveats the mean values of μ_s for the three experiments using fresh colon without lubrication were reasonably consistent.

The measurements for static friction made with the urinary catheters were more consistent than those for the endoscope. Perhaps this is because the hydrogel provides something akin to a squeeze film of water between the surfaces so that variations between samples of colon matter less.

Moving on now to the different experiments that were performed with the endoscope, the following observations can be made.

It can be seen from the first three experiments that the coefficients of friction with defrosted colon were similar to those with fresh colon. This result helps validate the use of defrosted colon with models used to test novel approaches to endoscopy.

The results recorded with KY Jelly and mineral oil do not adequately reflect what was very clear at the time the experiments were being performed and what could be felt by manually pushing the toboggan along the rails; that the KY Jelly was rapidly wiped off while the oil formed a very viscous paste that made all but creeping progress very difficult. It was clear that using mineral oil would not help the endoscopist although it did lower the coefficient of friction.

The reason for applying fat to the endoscope when it is being used in conjunction with an overtube is clear. The overtubes are made from rubbery materials (frequently silicon rubber) and dry rubber has very high friction when rubbed against a dry plastic surface such as an endoscope's. A small amount of fat will greatly reduce this while, as can be seen from the measurements, it makes little difference to the coefficient of friction with

respect to wet tissues. As a rough experiment the colonic tissues were replaced with latex rubber (Dunlap Amber, Kent Latex Products, Akron, Ohio, USA) and the angle at which slip started was 47° giving $\mu_s = 1.05$.

It can be seen that adding a small weight appears to slightly lower μ_s , though the effect is not very pronounced. This was slightly surprising but it was not investigated further because the difference is insignificant compared with the difference produced by using hydrogel coated surfaces.

7.2.4 Conclusions regarding the frictional properties of an endoscope shaft compared with those of hydrogel coated catheters.

It was concluded from the measurements that a hydrogel coated sleeve offered a very considerable reduction in friction and that it would be worth building prototypes which could be used in models and human studies.

7.3 Prototype development

It will be remembered from the Introduction to this chapter that it was proposed to develop a disposable hydrogel coated lubricating sleeve that could be slid over an endoscope to facilitate colonoscopy.

Any sleeve would have to meet the following criteria;~

- Patient safe

- No possibility of damaging the endoscope

- Easy to put on and take off

- Does not reduce the clinician's ability to grip the endoscope so as to push, pull or twist it.

- Practical to make in prototype quantities

- (Could be made inexpensively in large numbers)

Although patient safety is the prime concern it was not the first criterion used to help define the design. From that point of view the first question was whether the sleeve should be tight fitting or baggy. A tight fitting sleeve is harder to put onto the endoscope but it has the advantage that it is less bulky in the colon and is less likely to interfere with applying torque to the endoscope shaft. Against this has to be set the major disadvantage that once the tight sleeve has become wet the clinician must handle the shaft of the endoscope through an extremely slippery coating. A quick test suggested that the endoscopist would have to exchange his latex gloves for "pebble grip" gloves. By contrast the portion of a baggy sleeve that is external to the patient can easily be slid along the endoscope and bunched-up close to the anus leaving the bare endoscope shaft for the endoscopist to handle.

It is clearly desirable to use a thin walled tube to maximise flexibility and minimise the bulkiness of the tube around the endoscope. Excellent flexibility is needed because the steerable portion of the colonoscope has to be able to bend through very tight angles without over straining the endoscope's Bowden cable and universal joint mechanism which is one of the most common areas for damage to colonoscopes. Extreme flexibility is also needed to allow the baggy sleeve to be bunched up around the endoscope shaft external to the patient.

Making it easy to put on or take off the sleeve and to bunch it up during the procedure requires that the inside of the sleeve slide freely against the endoscope shaft. Whilst this could be achieved by appropriate lubrication, the simplest solution is to make the sleeve out of a material that slides freely against the dry plastic surface.

A number of plastics could be suitable and polyamide (Nylon) was chosen because it was readily available, it could easily be welded to shape the sleeve as desired and because the company that was to coat the sleeves had experience with Nylon and did not foresee major problems. Figure 7.12 shows an uncoated prototype sleeve fitted over a Pentax Endoscope. The sleeve was made from a metre length of layflat Nylon 6 autoclavable tubing with a diameter of 32 mm and a gauge of 0.1 mm, supplied by Portex (Hythe, Kent).

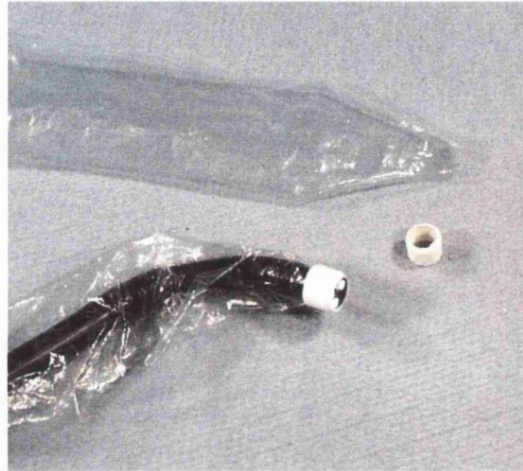


Figure 7.12 Nylon sleeves and silicone rubber bands with an endoscope.

The tapered part of the sleeve was made by first clamping the tube between two triangular aluminium plates, then using scissors to trim back the Nylon to the edge of the metal plates, and finally using a hot air gun to melt the boundary and form a welded seam.

The rubber band was shaped to fit the tip of the endoscope without covering the optics or the openings to the biopsy or water channels. It was made by casting LSR30 silicon rubber (Applied Silicones, Ventura, CA, USA) in a two part PTFE mould.

7.3.1 Patient safety.

The sleeve could prove hazardous either because the materials it contains are not sufficiently biocompatible or because of a mechanical failure.

So far as biocompatibility is concerned, the application is minimally invasive, involving insertion into the colon for periods of up to one hour. Hydrogels are used for far more demanding applications.

This is a simple device and there are very few ways in which mechanical failure might affect it. The most likely failure is a tear or hole in the sleeve however, as the sleeve does not provide sterility, this would not pose a hazard. Another possibility is that the silicon rubber cap becomes detached and is left behind after the endoscope is withdrawn. Once again this does not pose a hazard as the small and soft object would be passed without difficulty.

7.4 Prototype Manufacture

Having chosen a design it was decided to undertake a patient study at the Royal London Hospital. Ethics Committee approval was sought and was granted with the proviso that the Medical Devices Agency should approve the design. Unfortunately, the Medical Devices Agency said that this was not the type of project they dealt with and referred it back to the Ethics Committee. Five months after the original application, permission was granted and thirty prototypes were made and sent to STS Duotek (Henrietta, NY, USA) for coating with 'Slip-coat'. Although the company had been sent details of the sleeves and had not anticipated any problems, they found that they were unable to make the coating adhere to the Nylon sleeve and, after a further six weeks, returned the sleeves untreated.

At the time of writing, suitable tubing made from materials that can easily be coated is being sought.

7.5 Conclusion

It had been intended to round off the PhD project with a series of results from trials in humans but technical problems have stalled this work and left it without any clear conclusion. The preliminary study was encouraging and showed a clear reduction in

friction with hydrogel coated surfaces when used *ex vivo*. Also, if the sleeves can be made at all, then they can be made inexpensive and safe.

None of this answers the question of whether the reduction in friction is sufficient to be of clinical value. It is hoped that in the near future it will be able at least to begin to address that question.

8 Concluding remarks

The aim of this project has been to reduce the difficulty, time and pain of conventional colonoscopy by creating novel devices to assist with advancing a colonoscope around the colon to the caecum. Discussing possible solutions with experienced colonoscopists and surveying the literature describing previous attempts to do this, showed that the range of possible solutions was extremely wide, with no one approach being particularly promising. In view of this, it was decided that rather than intensively pursuing one approach, the feasibility of a number of different approaches would be investigated.

Given the width of the field, it was difficult to decide which tracks to follow but in the end four different approaches were chosen. For each approach an attempt has been made to assess its prospects initially with theory and bench tests before proceeding to build elementary prototypes which could be tested in models. It is now time to look back at the devices and assess which still look promising and which directions further work should take. There follows a brief list of the principal advantages and disadvantages of each device followed by a few closing sentences.

8.1 Water Jet

Advantages;

Effective at providing propulsive force at the endoscope tip.

The spray heads are hygienic and inexpensively.

Robust and reliable.

Disadvantages

Inconvenience of scavenging and then disposing of waste water.

Extra tubing, plumbing and equipment (pump etc.) around the patient.

The heads and tubes add to the diameter of the endoscope. However, reducing the need to push might allow thinner endoscopes to be used.



Figure 8.1 Water jetting out of the spray head lifts an endoscope vertically upwards.

Safety. Considerable pressure is being introduced into the colon and it must be carefully controlled if it is not to be a hazard. Tests using excised colon from young pigs may not extrapolate to elderly humans.

Where next?

Professor Swain is applying to the Ethics Committee for approval to test the device in humans.

8.2 Suction crawler

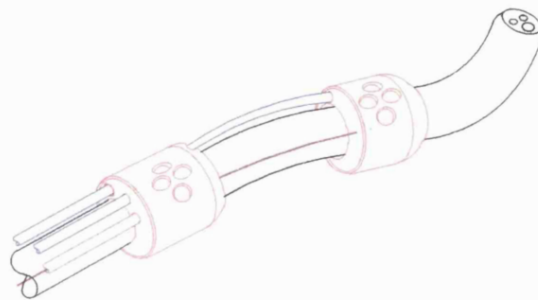


Figure 8.2 Suction crawler attached to an endoscope. The suction feet can be moved together and apart with a Bowden cable.

Advantages

The bowel wall can be easily and reliably gripped and pulled.

Safe.

The bellows driven system is effective at advancing around the model colon.

The cable driven system is moderately effective when mounted onto an endoscope.

Disadvantages

Complex to build. Difficult to make hygienic if not disposable.

More equipment and tubing around the patient.

The heads and tubes add to the diameter of the endoscope. However, reducing the need to push might allow thinner endoscopes to be used.

The bellows driven system requires fundamental redesign of endoscopic biopsy and surgery equipment. However it could be used for visual screening of the bowel or to lay a guide wire that an endoscope could follow.

Section 5.3 of the thesis drew attention to the possibility that bowel wall might contract and stretch in step with the suction feet so that no net progress would be made (see Figure 5.8). This has not been a problem with model colons but might be in, for example, a poorly attached transverse colon of a human.

The appearance of “Love bites” might confuse the clinician.

Where next?

A properly engineered prototype should be made. Too many of the problems have arisen from poor reliability and inconvenience. Since the system appears to be safe, it should be possible to test it in humans once a reliable system has been made.

8.3 Electrical stimulation of the muscles in the gut wall.

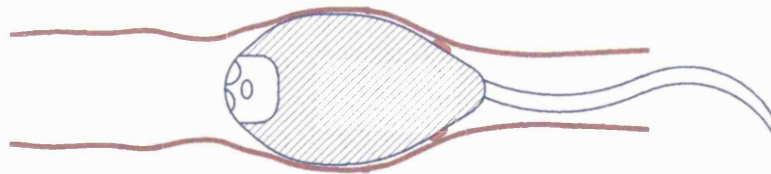


Figure 8.3 Electrodes stimulate the muscles in the gut wall to contract, squeezing the lozenge shaped device forward.

Advantages

Effective, especially for the small bowel.

Simple to build and hygienic.

Automatic, in the sense that no operator skill is required to drive it.

Disadvantages

Possible danger of fibrillation if high currents are used. This issue is well understood and should not arise with proper design.

Possible danger of upsetting gut motility by disturbing the rhythm of natural peristalsis.

There has been no evidence of this following animal experiments and reports in the literature suggest it should not be a problem.

There is a dilemma over the size of the device. It should be large enough to fill the lumen but also small enough to pass through one or other end of the bowel.

Where next?

A company has expressed interest in this approach and is wishing to fund further research. It is envisioned that this would involve a systematic effort to optimise the size and shape of the device and the electrodes as well as the pattern of electrical pulses delivered.

It is also intended to design and build a device that can expand or contract (e.g. a balloon) and to investigate the practicality of inducing contractions with a chemical such as acetylcholine, rather than using electrical stimulation.

8.4 Hydrogel coated sleeve.

Advantages

Safe.

Inexpensive disposable.

Convenient.

Disadvantages

Does it help? There is a suspicion that others have tried it and found it of no significant benefit.

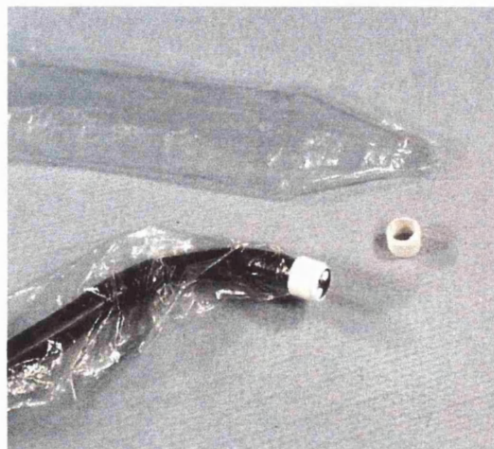


Figure 8.4 A sleeve coated with a lubricating hydrogel is attached to an endoscope. (The sleeve shown has not been coated.)

Where next.

There remains the need to find a suitable material for the sleeves and then make some sleeves that can be tested in humans.

8.5 Final comments

Inevitably with such “blue skies” devices, it is easy to think of reasons why they should fail. However it should be remembered that existing colonoscopy has serious shortcomings that cannot be overcome without radical changes to colonoscope design.

During this PhD project four novel approaches have been investigated and primitive prototypes have been built and tested. The three methods of providing traction have all shown promise and it is hoped and expected that further work will be carried out on them. The fourth method, the hydrogel coated sleeve, is perhaps the most practical of the proposals in that, if it works, it could be rapidly turned into a commercial product. It is most frustrating that this thesis must be written with this quadrant of the project left in such a tantalising state. Every effort will be made to take this approach forward before the final submission of the thesis.

Appendix 1 - Models of the colon.

A1 Introduction.

The material presented in this appendix is too slight to warrant a chapter of its own but does not fit easily into any of the chapters describing specific endoscopic devices. It has therefore been relegated to an appendix.

The models of the colon that are described were made to test the prototype devices built for the work presented in this thesis. However the most interesting application for a realistic model would be in teaching colonoscopy which is currently learnt by observing a skilled practitioner at work and then practising on patients. It has been estimated that it takes two hundred procedures before a colonoscopist should be regarded as fully proficient¹.

“Teaching” models of the colon are commercially available. They are made from vulcanised rubber and are shaped and coloured to look very realistic when viewed through an endoscope; indeed it is rather enjoyable to push an endoscope along the Olympus model and play ‘spot the polyps’. The problem with these models is that although they look good, they feel wrong; the rubber has most unrealistic mechanical properties. The rigidity of the rubber means that the lumen is always open, which removes the need for inflation and prevents the use of suction, both of which are important skills for the endoscopist. A more serious shortcoming, caused by the rubber being too rigid, is that the colon hardly stretches even when the endoscope is pushed with considerable force, so loops are not easily formed and the procedures associated with “pulling back and straightening out” are not required. The ease with which a real colon stretches is apparent during routine colonoscopy where it is common to have to insert 1.4 to 1.6 metres of endoscope shaft when pushing past the hepatic flexure, yet only about 0.8 metres of endoscope remain inside the patient when the colonoscope has reached the caecum and the endoscopist starts to pull it back.

As well as being too rigid, the rubber also has very different frictional properties compared with real colon. The chapter dealing with hydrogel coated sleeves describes a

system that was built and used to measure the coefficient of friction of colonic tissues sliding against an Olympus CF 1TI endoscope. It can be seen in that chapter that the dynamic coefficient for tissues is about 0.15. The same rig was used to measure dynamic coefficients of friction between the endoscope and rubber and the results of three separate measurements were 0.51, 0.58 and 0.53 (mean 0.54). These results should be treated as no more than indicative since the rubber (Dunlap Amber, Kent Latex Products Inc.) was not the same as that used in the model, which had been on loan from Olympus, and the friction also depends on the cleanliness of the surface which on the inside of a model is not at all well defined.

It will be seen that the models produced as part of this thesis address these problems and go a long way, but not all the way, towards producing a model that would be useful for teaching.

The American Society for Gastrointestinal Endoscopy (ASGE) has recently produced a three page technical status evaluation report on endoscopy simulators which reviews the literature². The summary section of that report will serve to end this introduction. "Each of the simulators described attempts to achieve an accurate simulation of endoscopy in human patients. Mechanical models are potentially useful for the development of hand-eye coordination but have been criticized for a lack of realism. Realistic computer simulators will likely become available in the near future. Currently, live animal models provide the most accurate simulation but are limited by anatomic differences compared to humans and the inability to simulate pathology. Ex vivo animal models allow some simulation of pathological states. Studies demonstrating benefit are awaited."

A2 Plastic and rubber model colons.

Initially, two models were constructed which were difficult to endoscope with a conventional instrument. The simpler of the models used a length of transparent PVC tube (ID 1" and OD

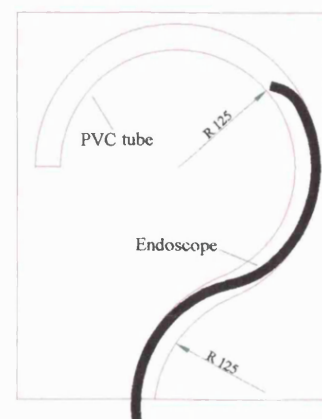


Figure A.1
The '?' model colon

1¼”) that was softened with hot water and then pushed into a ‘?’ shaped slot milled in a wooden board. When the endoscope was pushed around the loop its shaft would stick against the walls of the tube and become jammed so that harder pushing simply locked the endoscope more firmly in place. This model was constructed for use with the water jet propelled endoscope and it showed that a short blast from the jets would pull the shaft free from the wall and allow the endoscope to be pushed further around the ‘?’.

A more realistic looking latex rubber model was constructed as follows. A 70 cm length of corrugated steel ‘flexible’ vacuum tube was bent into an artist’s impression of a colon from the anus to midway across the transverse colon, this was then covered with lagging from a plumbers merchant which was itself bound with a self adhesive scrim and then a layer of plaster impregnated bandage. Once hardened the plaster was painted with PVA adhesive to make a non-porous surface which was painted with three coats of latex (MR Revultex supplied by Regent). The rubber colon was then unrolled from the model like an elephantine condom and, once unrolled and placed on a wooden board, strips of rubber were glued to it to hold it in place on the board and simulate mesenteries.

This model suffered with all the problems associated with the commercial rubber models except that it was far less expensive (the Olympus model colon costs \$2,340²). It had the added disadvantage that unless it was thoroughly cleaned and dried before storage the rubber in the wet areas would age and become prone to cracking. Nevertheless it was useful for assessing the water jet system and results found with it are described in Chapter 4.

When handling excised porcine colon it immediately became obvious that standard, readily available, plastics and rubbers had completely different mechanical properties and that finding a suitable material, particularly in the very small quantities that we needed, would be very difficult if not impossible. It was therefore decided to make models using excised colon which was available in small quantities from the animal houses at UCL and the Royal London Hospital and could potentially be obtained in large quantities from abattoirs.

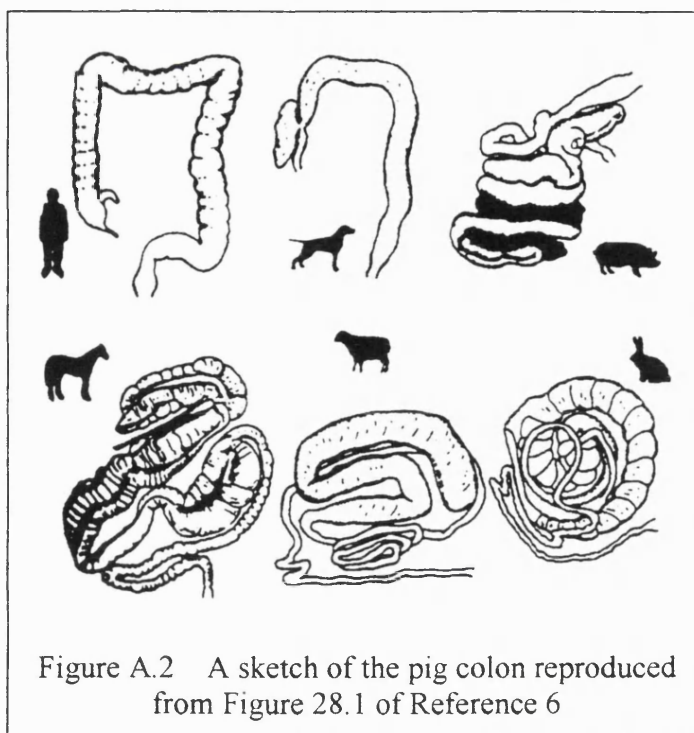
A.3 Methods for making models using excised porcine colon.

At the time we started building these models we were unaware that models using excised colon had already been described, albeit in a rather obscure publication, by Carroza³ et al. This was the same publication that described their ‘suction crawler’ and, presumably, it was being faced by a similar problem that had led them to a similar solution. The recent ASGE technology status report references a sophisticated model that has been presented by a group at Erlangen where excised porcine visceral organs are placed within a plastic torso and citrated blood can be used to perfuse the organs or simulate arterial spurting^{4,5}.

A model to simulate the human colon requires three principal components; the colon itself, the mesenteries that attach the colon and the surrounding anatomy that determines the shape of the colon. The methods for producing these three components will now be described.

The colon was simulated by lengths of pig colon. The procedure used to collect colon from freshly sacrificed pigs was the same as described in Chapter 7, except that immediately after the mesenteries had been cut away, the colon was cut into lengths of about 80 cm and then briefly flushed with cold water before being packaged and frozen for future use. The colon could generally be refrozen and reused once or twice before it aged too much to be useful. The ageing process consisted of liquids (presumably blood and mucous) leaching out of the colon wall which became progressively greyer and less slippery, ~ more papery. Most of the ageing appeared to take place during freezing and thawing though it is not clear whether this is the result of ice formation itself or just the amount of time spent slowly freezing it in a domestic fridge and then thawing it at room temperature. There was never a problem with the colon ageing significantly during an experiment except that when the water jet propelled endoscope was being repeatedly run along a length of colon it washed the lubricating mucous off the surface.

The method for making model mesenteries initially appeared to pose more of a problem. It was not practicable to use the mesenteries that were still attached to the pig's colon after it had been excised, because the pig's colon is far more tightly constrained into tight twists and turns than a human's. Figure A.2 is a sketch of various animals' colons⁶. The shape of the pig's colon defies description being rather like a couple of metres of Cumberland sausage randomly



squeezed into a tight fitting imaginary bag with both ends emerging side by side from the neck of the bag. Dr Swain has described it as a spiral helix but, when dissecting it, the convolutions are more apparent than the underlying geometry.

Stitching lengths of elastic to the edge of the colon also seemed impracticable as each length of colon would only be used once or twice. Brief attempts at using lengths of bandage as slings were unsatisfactory because the edge of the bandage formed a discontinuity against which the endoscope could jam. However Carroza³ et al describe using bandages to attach lengths of colon to scaffolding and report that results were satisfactory.

In the end it was decided to simulate mesenteries with the legs from nylon tights. The colon was partially inflated, to prevent it from becoming twisted, and fed through the hosiery which could then be pinned to a base board to define a curve, as can be seen in Figure A.3.



Figure A.3 Suction crawler in colon.

Nylon stocking stretches very easily which is desirable for a model colon as in the living human much of the colon is only loosely constrained and can be moved around by slight forces. The elasticity of the nylon stocking was shown by a brief experiment where a 50 mm wide (0.2 mm thick) strip of “10 denier appearance” Nylon stocking (The Boots Company, Nottingham) was gripped between clamps and stretched. It was found that a load of 1.09 N was sufficient to double the length of stocking from 125 mm to 250 mm. By contrast the same load only stretched a similar strip of latex (50 mm wide x 125 mm long x 0.17mm thick) cut from a ‘Finex’ disposable glove (Superglove, Cambridge) by 12%, from 125 mm to 140 mm.

The third component required for a model colon is the surrounding anatomy that anchors the mesenteries and in some places the colon itself and also provides cushioning for the colon. The model that was produced for this project was kept simple with the emphasis being placed on making it reproducible. Figure A.4 is a drawing of the system that was used to produce a sigmoid bend and Figure A.5 is a photograph of the model in use.

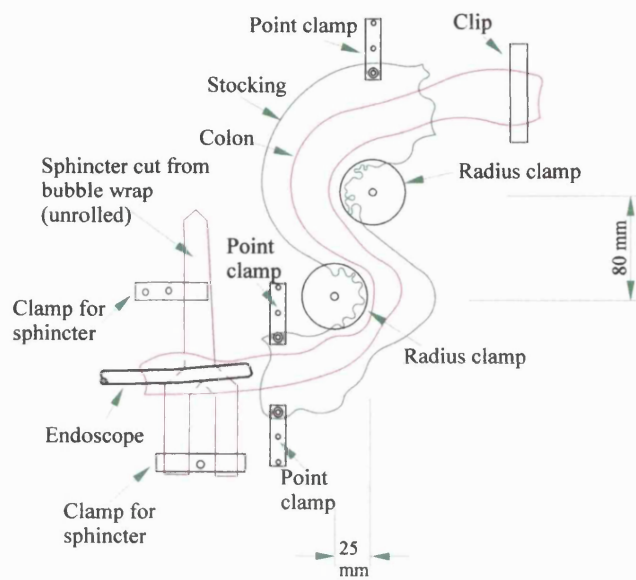


Figure A.4 Schematic diagram of model colon using nylon stocking to contain excised porcine colon.

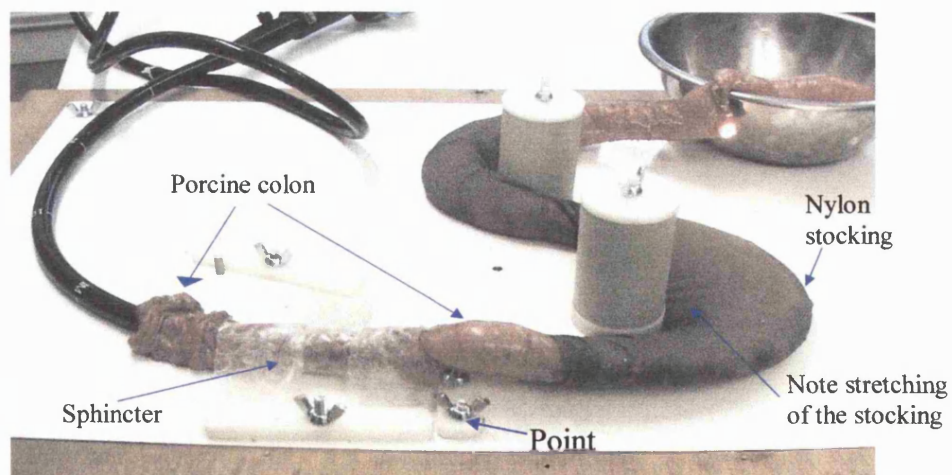


Figure A.5 Photograph of the model in use

The caecum, which is not shown on the photo, consisted of a ‘bulldog’ clip used as a clamp. The anal sphincter was constructed using a ‘Y’ piece of soft material (polyethylene “bubble wrap”) looped around the colon and tied like a belt. This sphincter worked well, allowing the endoscope to be freely slid back and forth with only a little air leaking out past the sphincter.

It can be seen that the radius clamps, which are illustrated in Figure A.6, were made with tall bodies. This was so that, as the endoscope was being pushed forward, it had to go around them rather than over them. When setting up the model, the stocking was first marked with an oil pen at five centimetre intervals and the colon fed through it. The acetyl 'C's were then slid into either end of the stocking and twenty centimetres of stocking was bunched up around each 'C' with ten centimetres being left loose between the two bunches. Finally, the 'C's were laid flat on the base board and the barrel of each clamp unit screwed down onto them as is illustrated in the assembly drawing on the right hand side of Figure A.5. The clamps were designed in this rather complicated way so that it was not too difficult to set up the model with consistent radii for the bends.

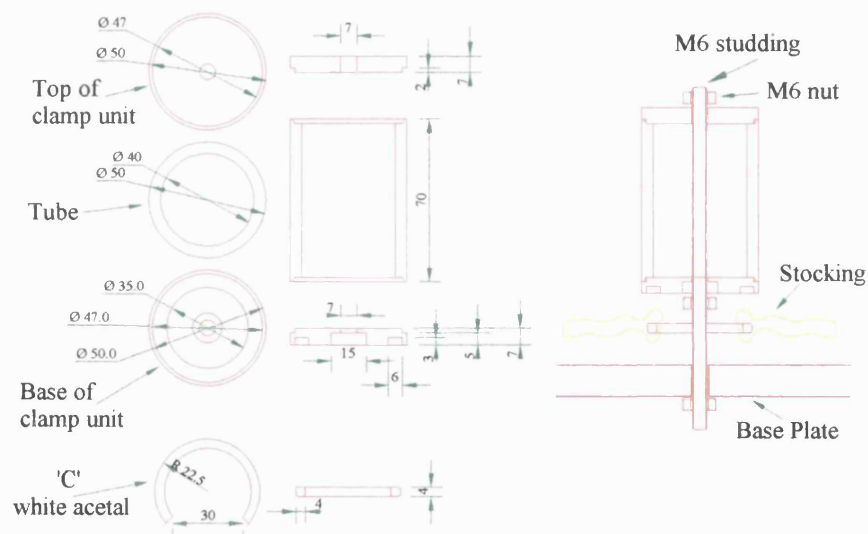


Figure A.6 Component and assembly drawings for the radius clamps

Results and Conclusions

The three experienced endoscopists who used the model said that it felt and, from the inside, looked realistic. It also required and responded appropriately to inflation and, as happens inside patients, the front lens became covered with mucous that had to be cleaned off. They particularly liked the way that the stretching of the stocking showed graphically where the bowel was being strained. It would be possible to quantify the strain of the stocking by drawing grid lines onto it before starting the procedure (or buying tartan hosiery) and then measuring the displacement of the lines as the endoscope is advanced. In principle this process could be automated, but it is hard to think of a better way of displaying the results than the image of the stocking becoming increasingly stretched.

The major weakness of the model is that it does not respond correctly to torque. When the endoscopist twists the shaft of the endoscope the colon twists around with it rather than straightening out loops and no benefit is derived. Dr Swain has found that the same happens when colonoscopy is performed during surgery where the stomach has been opened and this suggests that the problem lies not with the nylon mesenteries but with the lack of cushioning which is normally afforded by the abdominal wall retaining the internal organs. Given more time it might be possible to make a more realistic model and it is hoped in the future to experiment with cushioning to see whether it is possible to produce a model that responds appropriately to torque.

Appendix 2 Forces exerted during oesophageal dilatation

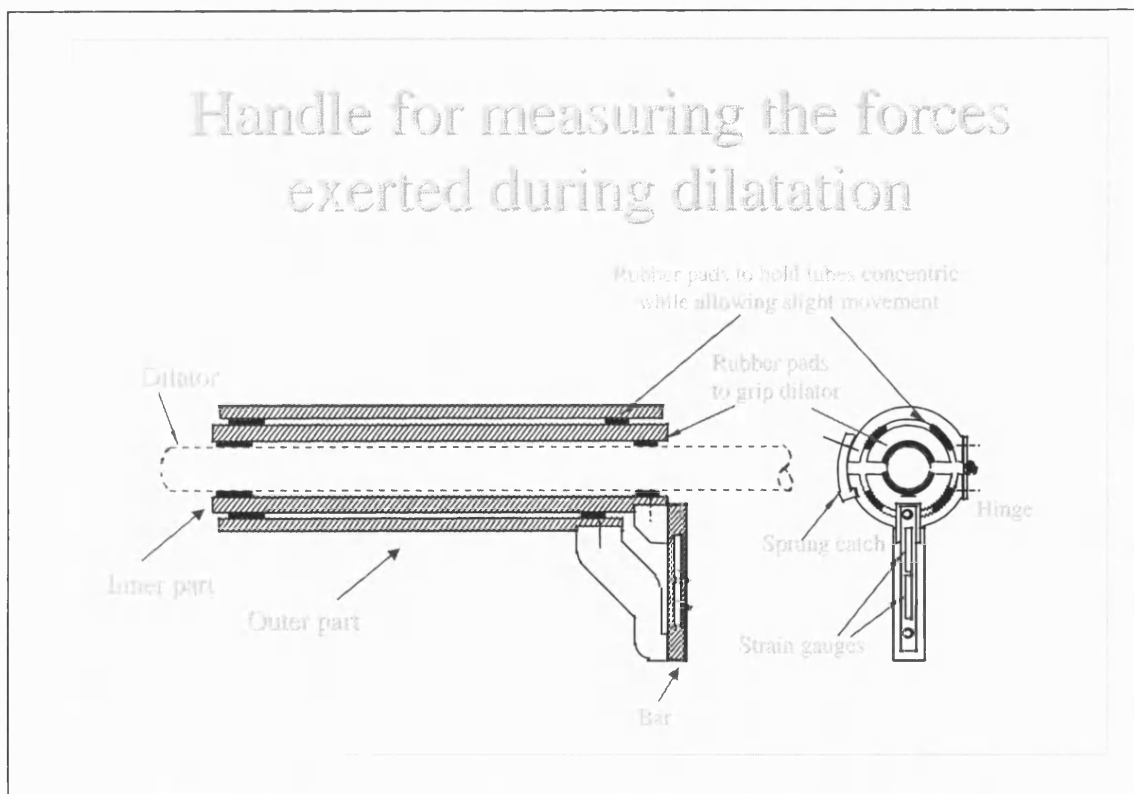
The following pages reproduce in black and white a poster that was presented at the British Society for Gastrointestinal Endoscopy annual meeting in 1997. (It is referenced in the text as, Gastrointestinal Endoscopy 1997;45:AB75)

The authors were

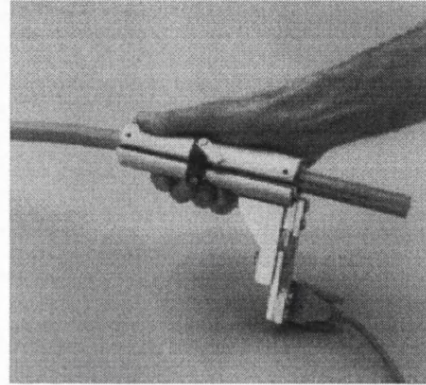
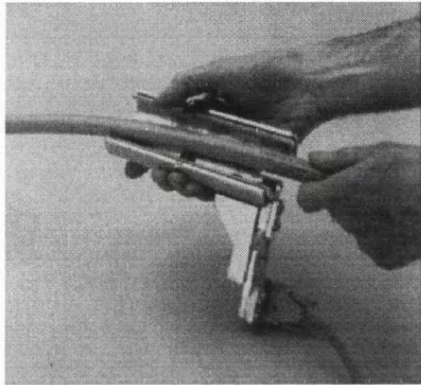
CA Mosse and TN Mills, Department of Medical Physics, UCL.

GD Bell, Ipswich General Hospital,

CP Swain, Royal London Hospital.



Using the handle to grip the dilator



Aim

- An electronic device was designed and built for use during oesophageal dilatation to allow measurement of the forces exerted on a bougie dilator.

Design of the handle used to grip the dilator

- The handle is in the shape of a hinged split cylinder which can be locked around the dilator.
- The handle has two parts, an inner that grips the dilator and an outer that is gripped by the clinician.

Design of the handle -2

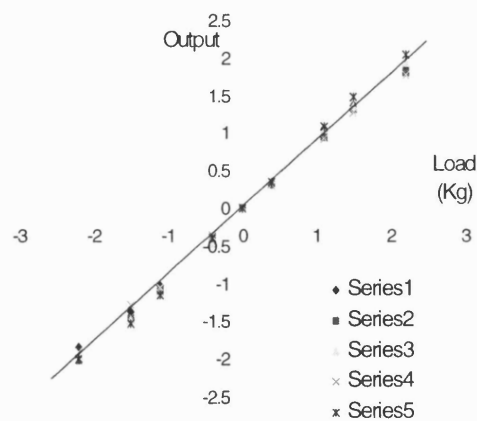
- The inner part is joined to the outer by rubber pads that allow some movement. But in one place they are also attached by a relatively rigid metal bar.
- When the outer part is pushed the bar bends slightly as it transmits the force to the inner part and hence the dilator.

Electronics.

- A pair of strain gauges is mounted on the bar to measure the forces.
- The gauges form half of a Wheatstone bridge and a cable connects them to an amplifier and electrical isolation unit.

Calibration

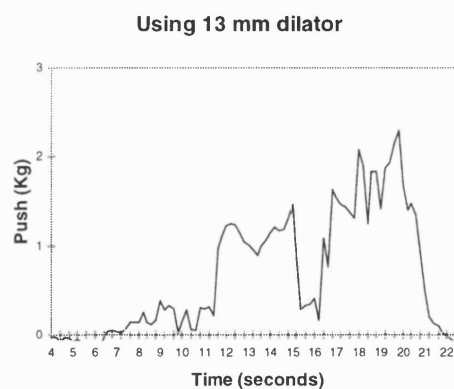
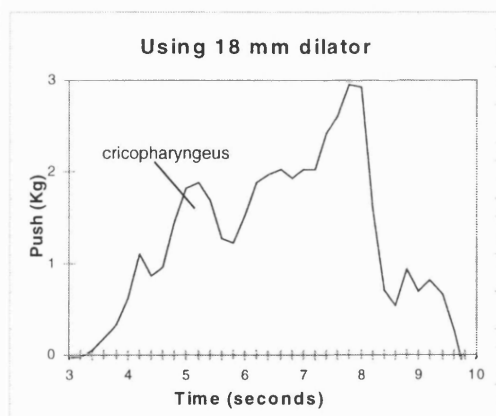
Push/pull calibration



Results

- In a preliminary study forces at dilatation were measured in 10 patients using 2 thermoelastic oesophageal dilators of 13 and 18 mm (Savary and Celestin).
- The duration for which thrust was transmitted to the oesophagus ranged from 10 to 21 seconds.

Force required during dilatation



Force measurements

■ Peak forces

- ◆ To cross stricture = 0.4 - 3.8 Kg
- ◆ To cross cricopharyngeus = 0.25 - 1.3 Kg
- ◆ Mean for 18 mm dilator = 2.3 Kg
- ◆ Mean for 13 mm dilator = 1.5 Kg

Conclusion

- These measurements represent the first accurate measurements of the forces exerted during oesophageal bouginage.

Appendix 3 Copy of a document, written early in the PhD project, outlining the different approaches that then appeared possible.

Proposed Methods of Improving the Insertion of Colonoscopes.

Sandy Mosse July 1996. Revised and items E, F and G added November 1996.

This is a list of the methods which might warrant further investigation. It does not include ideas such as the "endobot" (which, I believe, is not practical with existing technology) or the "snake robot" (which is already being very actively pursued at Cedars Sinai). Also it does not mention the idea of attaching a weight to the end of the scope and mounting the patient on a gimble (which is attractive but too silly to be credible).

A. Crinkly straw (suggested by Dr Duncan Bell).



As the straw is inflated so the paediatric endoscope is pulled into the colon.

Advantages:

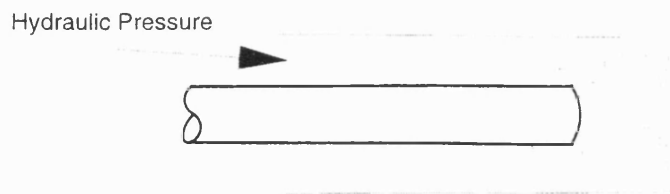
1. Assuming that the straw expands from the proximal end first, then only the tightly folded section has to slide past the colon wall which considerably reduces total friction.
2. Being hydraulic, push is transmitted around corners.
3. Duncan Bell is keen to use three small straws arranged in a triangle around the endoscope so that the system can be steered.

Disadvantages, apart from inconvenience, reliability and other "practical" problems.

1. You must ensure that it expands from the rear, or proximal, end.
2. Only the crests will rub against the colon. Is this a disadvantage?

3. It is still basically pushing a flexible tube so it will still tend to expand out a loop rather than sliding through it.
4. I suspect that the straw will not carry torque as well as a colonoscope, or that if it does it will be too flexible and not straighten out loops as it is twisted.

B. Everting tube.



Note. In practice the inside tube must be fed out so that the front of the tube rolls smoothly.

A thin walled tube is everted (i.e. turned inside out so that it passes through itself) and the endoscope is attached to one end as shown. Hydraulic pressure is then applied to force the tube to unroll on itself and pull the scope into the colon. While it is unrolling the endoscopist can see nothing but the inside of the tube, but the tip of the scope emerges from the tube as it finishes unrolling and the scope can then be pushed on further or pulled back with the tube.

Everting tubes have been used in a number of medical applications. A very brief search revealed the following references, copies of which are in my ring-binder;

Transcervical access...using a new technique for Fallopian access, Otto Bauer et al, Human Reproduction, Vol 7 Suppl 1 p7- 11, 1992.

The toposcopic through-lumen everting catheter to facilitate dilation of severe strictures of the g.i. tract. Benjamin S.D. Collins K.S. Gastrointestinal Endoscopy, 32 #1 33 - 35, 1986.

Everting (Toposcopic) catheter for broad clinical application. Shook et al, J Biomed Eng, Vol 108, May 1986, 168 - 174. (This is the best article).

Advantages;-

1. There is only rolling contact between the tube and the colon wall.
2. The scope is pulled through the tube, you are not pushing on a string.
3. One can imagine that the everting tube will find its own way painlessly around corners, like a column of water being pushed up through the colon.

Disadvantages;

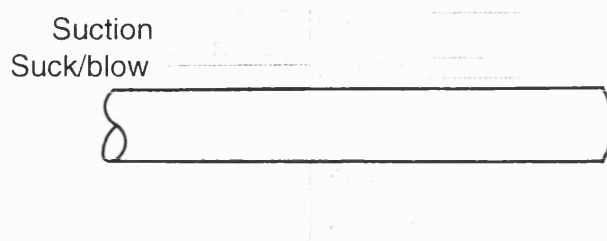
One can imagine that the tube will not find its own way around corners, but on the contrary will steer into the wall and jam.

The endoscopist is blind on the way up and can only see the colon once the tube has fully unrolled (reverted??). However on the way back visibility is unimpeded and a more flexible endoscope could be used.

A common problem during colonoscopy are blind alleys leading off the colon called diverticula. The colonoscopist must be able to see these if he is to avoid going up them.

The tube must be short enough that it is fully unrolled before the caecum is reached. The tube will have to be the right length to end somewhere in the ascending colon, or it could be used with an imaging system and pulled back if it appears to be getting close to the caecum.

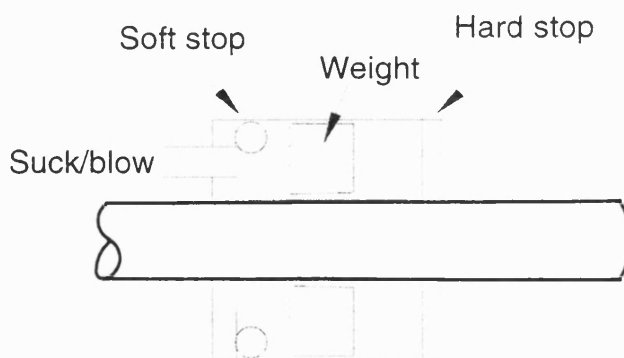
C. **Snail (Feng Gong, Tim Mills & Paul Swain)**



This is a variant on the various earthworm systems such as that described by Sugarbaker and Liddy (US patent 4,960,131 Sept1, 1987), except that it has the very important addition of suckers to enable it to grip the wall of the colon. Tim and Paul have had good experience with suckers in the past.

This approach is being investigated by Feng at UCL. It looks sensible.

D. **Hammer headed snake.**



By some means a weight is made to oscillate rapidly back and forth. On the backward stroke it is brought to rest gently by a soft stop, but on the forward stroke it hits a hard stop and hammers (or rather "taps") the endoscope forwards.

The problem is that to produce a reasonably hard tap the weight must be heavy and/or moving fast and it may be difficult to do this in practice. The attraction of the idea is that it is potentially a very compact of getting a pulling mechanism in place with only one moving part.

(P.S. August 1999. A reference to this system was found- . Ohmichi O, Yamagata Y, Higuchi T Micro impact drive mechanisms using optically excited thermal expansion J. of Micro-electromechanical Systems 6, 1, 41- 47, 1997 - but the pneumatic model we made was a total failure).

E. Alternately rigid or flexible support.

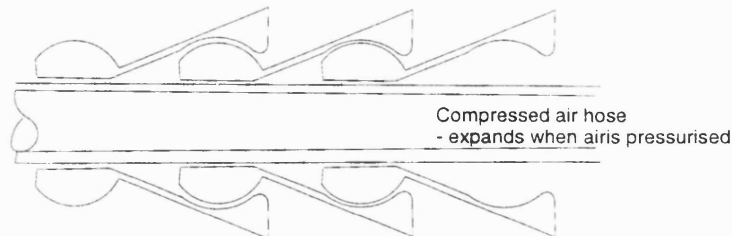
The principle of this is that the scope can travel over or through a support that can alternately be made flexible or rigid. The scope is first advanced a small distance into the colon, then the support is slid along the scope until it reaches the end of the scope, it is then made rigid. The clinician can then push the scope forward again with the forces being reacted against the rigid support rather than the colon wall. This cycle is repeated for as long as necessary.

So far two references have been found to systems like this:-

IEEE Int Conf on Robotics & Automation 1993

US patent 5,337,733 1994 Tubular inserting device with variable rigidity

Before finding these references my version of it was the “Lockable Lube Line”.



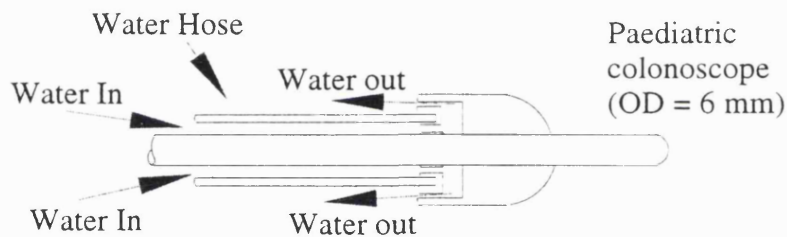
Three elements of a lockable lubrication line with a flexible compressed air hose running through the middle of them.

The idea is based on the kind of lubrication line illustrated above. The line would be modified so that it became very flexible by slitting the ball ends of the "shuttle cock" components. The tube could then be made rigid by pressurising the air hose so that it squeezed out on each ball end and locked it into the tail of the next shuttle cock.

This would involve a fundamental redesign of the endoscope so that it would be a sleeve running outside the lockable lube line.

I do not think this idea is worth pursuing further.

F. Water Jet



The principal is that the front of the colonoscope is propelled forward by shooting out jets of water (or some isotonic solution). If the water flow is 'Q' with a forward velocity of V_f as it travels up the hose and backward velocity of $-V_b$ as it leaves the jets, then the change in momentum per unit time is $Q(V_f + V_b)$ Newtons (= kg/sec x m/sec).

For short bursts one can imagine using high flow rates and high velocities.

Advantages:-

Can be fitted around an existing scope.

Practical to make.

Practical to calculate.

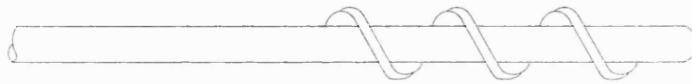
Disadvantages:-

Clinical implications of flooding the colon. (How wet is colonic irrigation?)

Messy where the water flows out of the anus

Conclusion; this warrants closer investigation.

G. Corkscrew.



Some kind of soft, smooth and flexible screw is attached to the scope just proximal to the steerable tip. By rotating the scope it will screw its way along the colon or pull the colon back over the scope. An alternative is to have a short screw travelling just in front of the scope, or perhaps just at the tip of the scope, which is turned separately to the scope with power supplied down one of the biopsy channels.

It is hard to believe that this will not twist the colon which could be very dangerous. It is particularly hard to visualise the scope screwing its way around a tight corner.

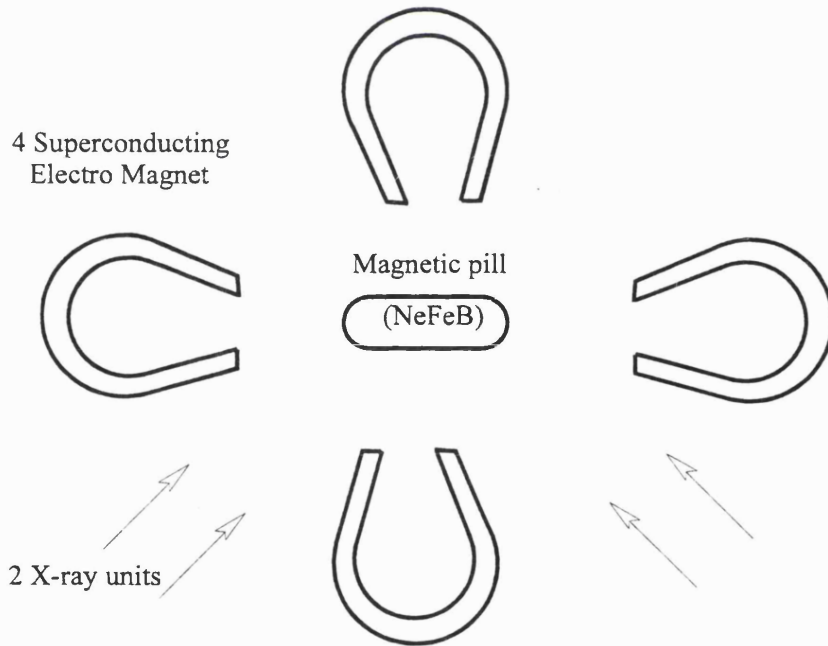
H. Corkscrew in a condom (or “sidewinder snake”).



This is similar to 'G' except that the scope does not rotate and the screw is covered by a sack which is attached to the scope so that it also does not rotate. As the screw is turned so waves travel along the sack and the scope advances like a sidewinder snake.

As with 'G', it is hard to imagine it making its way around a tight corner without snagging the sack or the surrounding colon.

I. Magnetically Steered.

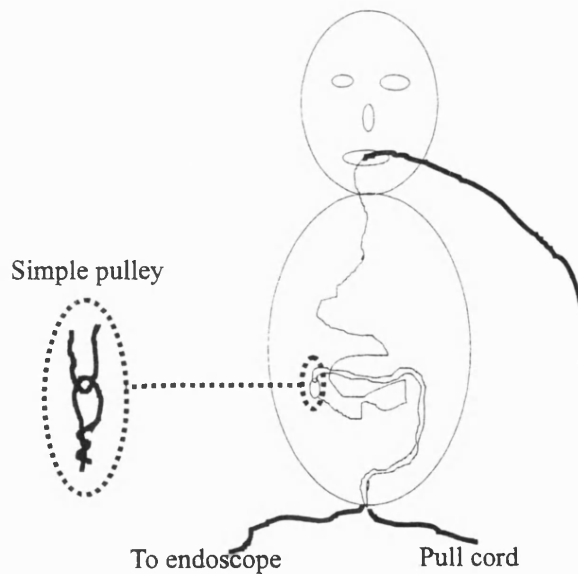


Reference McNeil et al in IEEE Trans Biomed Eng 42/8 pages 793 - 799 Aug 1995,
Functional design features and initial performance characteristics of a magnetic-implant
guidance system for stereotactic neurosurgery.

It is possible to focus a magnetic field so that it can steer a small permanent magnet in three
dimensions. As you cannot magnetically image at the same time you must also employ
another modality such as CT. The above article does not state the forces developed, but a
sister article implies that theoretically they could be as high as 0.2 N.

This does not look at all practical for colonoscopy. (*P.S. September 1999. See section 2.4.5
of the thesis. The inventors have raised \$18M to pursue the idea!*).

J. Oral Entry



The first retrograde colonoscopy was achieved by Provenzale and Ravnias in 1965 by
passing a long thin polyvinyl tube through the entire GI tract which could then be used to

position an elementary pulley in the caecum. The pulley could then be used to pull a gastroscope back through the colon.

Although this system worked it proved too inconvenient to be practical.

In principle Sonde endoscopy might be extended to the colon, but once again it is inconvenient. Also there is the issue of pulling the endoscope back through the gut.

References

References to Chapter 1

- ¹ Church JM. Endoscopy Of The Colon, Rectum And Anus P.111 Igaku Shoin, New York. 1995
- ² Baille, J. Gastrointestinal Endoscopy. Basic Principles And Practice P 66. Butterworth Heinemann, Oxford. 1992.
- ³ Damore II L J, Rantis PC, Vernava III AM, Longo WE. Colonoscopic Perforations, Etiology, Diagnosis And Management. *Disc. Colon Rectum*; 39, 11, 1308–14, 1996.
- ⁴ Rankin, GB. Indications, Contraindications And Complications Of Colonoscopy. In Sivak MV, Ed. *Gastrointestinal Endoscopy* P868-80. WB Saunders, Philadelphia. 1987.
- ⁵ Habra-Gama A, Wayne JD. Complications And Hazards In GI Endoscopy. *World J Surg.* 13, 193-201, 1989
- ⁶ Habr-Gama A, Vieira MJF, Alves PA, Sousa Jr. AHS, Sototuka, JK, Gama-Rodrigues J, Travassos VHCR, Preparo Do Colon Para Colonoscopia. Estudo Prospcctivo Randomizado Com Solucao De Manitol A 10% E Com Solusao Eletrolitica Contendo Polietilenoglicol. *Revista G.E.D.* 5:127, 1986. Quoted In Habra-Gama 1989.
- ⁷ Davis RE, Graham DY. Endoscopic Complications. The Texas Experience. *Gastrointest. Endosc.* 25: 146, 1979. Quoted In Habra-Gama 1989.
- ⁸ Damore LJ, Rantis PC, Vernava AM, Longo WE. Colonoscopic Perforations. Etiology, Diagnosis And Management. *Dis Colon Rectum*, 39:1308-14, 1996.
- ⁹ Cotton PB, Williams CB. (1996), "Practical Gastrointestinal Endoscopy", 4th Edition P.189, Blackwell Science, Oxford.1966
- ¹⁰ Cotton PB. And Williams CB. (1996), *Ibid* P.168
- ¹¹ Hallstrom. The National ASGE Colonoscopy Study. *GI Endosc* 30, 156, 1984.
¹²Northover JMA, Kettner JD. *Bowel Cancer- The Facts*, p. viii. Oxford Univ. Press, Oxford. 1992.
- ¹³ Luk GD. *Cancer Surveillance Strategies. GI Disease: Pathophysiology, Diagnosis, Management*, 5th Ed. Sleisenger MH Et al. W.B.Saunders Co. Philadelphia. 1996ger MH Et al. W.B.Saunders Co. Philadelphia. 1996
- ¹⁴ Northover JMA (1992) *Ibid.* Page 9
- ¹⁵ Northover JMA (1992) *Ibid.* Page 35
- ¹⁶ Mulcahy HE, Farthing MJ, O'donoghue DP (1997). Screening For Asymptomatic Colorectal Cancer. *BMJ* 314, Jan 1997.
- ¹⁷ Luk GD (1996). *Ibid* Page 6.
- ¹⁸ Mulcahy HE (1997).*Ibid.*
- ¹⁹ Lieberman DA. Cost Effective Model For Colon Cancer Screening. *Gastroenterology* 109:1781-90 1995.
- ²⁰ Aitken WS, Cuzick J, Northover JMA, Whynes DK. Prevention Of Colorectal Cancer By Once-Only Sigmoidoscopy. *Lancet* 341:736-40. 1993
- ²¹ Wayne JD. In Haubrich Ws, Schaffner F, Berk Je, *Colonoscopy And Proctosigmoidoscopy*, Bockus, *Gastroenterology*, 5th Ed. W.B.Saunders Co. Philadelphia 1995.
- ²² Naitove, Smith IN. *GI Disease: Pathophysiology, Diagnosis, Management*, 5th Ed. Sleisenger MH Et Al W.B.Saunders Co. Philadelphia 1995
- ²³ Hunt RH And Wayne JD. Chapman And Hall, 1981, London. 1981
- ²⁴ Northover JMA (1992) *Ibid.* Page 12
- ²⁵ Haubrich WS (1995). *Anatomy Of The Colon*, In Haubrich WS, Schaffner F, Berk JE, *Colonoscopy And Proctosigmoidoscopy*, Bockus, *Gastroenterology*, 5th Ed. W.B.Saunders Co. Philadelphia 1995. Figure 80-8.
- ²⁶ Grant's Anatomy
- ²⁷ Northover JMA,(1992). *Ibid* Page 2
- ²⁸ Haubrich WS (1995). *Ibid.* Pages 1573 – 1581.
- ²⁹ Northover JMA, (1992). *Ibid* Page 8
- ³⁰ Haubrich WS (1995). *Ibid.* Pages 1573 – 1581
- ³¹ Saunders B, Md Thesis, University Of London. August 1996
- ³² Treves F. 1885 . Referenced in Saunders B, Md Thesis, University Of London. August 1996 page 26.
- ³³ Milne JS 1907 *Surgical Instruments In Greek And Roman Times*. Clarendon Press, Oxford. 1907.

- ³⁴ Edmonson JM. History Of Instruments For Gi Endoscopy. *Gi Endosc.* 37 No 2 Supplement S27-S56. 1991.
- ³⁵ Church JM. *Endoscopy Of The Colon, Rectum And Anus.* Igaku Shoin, New York. 1995
- ³⁶ Letter To Prof Horner, Quoted In Edmonson 1991 Page S28.
- ³⁷ Kelly H. A New Method Of Examination And Treatment Of Diseases Of The Rectum And Sigmoid Flexure. *Ann Surg* 21:468-478 1895. In Church 1995 Ibid.
- ³⁸ Tuttle JP, "A Treatise On Diseases Of The Anus, Rectum And Pelvic Colon", Appleton & Co, 1903 New York. In Church 1995 Ibid.
- ³⁹ Schindler R. *Gastroscopy, The Endoscopic Study Of Gastro-Pathology* University Of Chicago Press, 1950, Referenced In Edmonson 1991.
- ⁴⁰ Schindler R, (1950). Ibid Page S36
- ⁴¹ Morrissey JF. *Progress In Gastroenerology. Gi Endoscopy.* *Gastroenterology* 62, No 6, 1241-1260. 1972
- ⁴² Wolff WI. Colonoscopy: History And Development. *Am J Gastroent.* Vol 84, 9, 1017-1025. 1989
- ⁴³ Williams CB. *Endoscopic Instrumentation. Annual Of GI Endoscopy;*143 148-157. 1989.
- ⁴⁴ Hirschowitz BJ. *Endoscopic Investigation Of The Stomach And Duodenal Cap With The Fiberscope.* *Lancet* 1961 1074-78. Referenced In Edmonson
- ⁴⁵ Cohen NC, Hughes RW, Manfredo HW. Experience With 1000 Fibergastroscopic Examinations Of The Stomach. *Am J Of Digestive Diseases,* 1:949. 1966 Referenced In Edmonson
- ⁴⁶ Williams CB. (1989) Ibid.
- ⁴⁷ Overholt BF: Chapter In *The History Of Colonoscopy In Colonoscopy, Techniques, Clinical Practice & Colour Atlas.* Ed. Hunt RH And Waye JD. Chapman And Hall, 1981, London. 1981
- ⁴⁸ Saunders B. MD Thesis, London University. 1996
- ⁴⁹ Wolff WI (1989). Ibid.
- ⁵⁰ Provenzale L, Revignas A. An Original Method For Guided Intubation Of The Colon. *GI Endosc;* 16: 11- 17, 1969.
- ⁵¹ Morrissey. *Progress In Gastroenerology. GI Endoscopy.* *Gastroenterology* 62, No 6, 1241-1260, 1972
- ⁵² Bisacre M. *Probing The Inner Man. Insight, Part 1.* Ed. Bisacre M., Marshall Cavendish Partworks Ltd, London. 1980.
- ⁵³ Katzir A. *Lasers And Optical Fibers In Medicine.* Academic Press, London. Pages 158-159, 1993

References for Chapter 2

- ¹ Bell GD, Rowland RS, Rutter M, Dogramadzi S, Allen C, Mosse CA, Mills TN, Swain CP: Routine use of a stiffening overtube during colonoscopy – would it shorten the procedure. Presentation at British Soc of Gastroenterology, March 1998, Harrogate, UK.
- ² Bauerfiend P, Bauerfiend H. Tubular inserting device with variable rigidity. US 5,337,733 (1994)
- ³ Frazer RE,. Apparatus for endoscopic examination, US patent 4,176,662 (1979)
- ⁴ Sturges RH, Laowattana S. A flexible tendon-controlled device for endoscopy. Proc 1991 IEEE Int Conf on Rob & Automation, 1991.
- ⁵ Frazer RE, *ibid.*
- ⁶ Krasner Medical apparatus having inflatable cuffs and a middle expandable section, US patent 4,676,228 (1987)
- ⁷ Shishido Y, Adachi H, Hibino H, Yamamoto T, Miyana H, Takayama S, Ueda Y, Aoki Y, Yamaguchi S Pipe inspecting apparatus having a self propelled unit, US patent 5,090,259 (1992)
- ⁸ Post script. This reference number inserted in error.
- ⁹ Krüger (1995). Insertion assisting device for medical instrument, US patent 5,454,364
- ¹⁰ Liddy J, Sugarbaker PH, Penland WZ. Medical apparatus, US patent 4,690,131 (1987)
- ¹¹ Sugarbaker PH, Penland WZ, Liddy J: Pneumatic device for the automated advancement of the fiberoptic endoscope for total colonoscopy. *Gastrointestinal Endoscopy* 31, 3:210-213, 1985
- ¹² Grundfest W, Slatkin BA, Burdick J: Rodotic endoscopy. US patent 5,337,732. 1995
- ¹³ Slatkin BA, Burdick J, Grundfest W: The development of a robotic endoscope. Dept Mech Eng. Caltech, brett@robby.caltech.edu 1996
- ¹⁴ Slatkin BA *Ibid*
- ¹⁵ Guber AE: Potential of microsystems in medicine. *Minimally invasive therapy* 4: 267- 275, 1995
- ¹⁶ Carroza MC, Dario P, Lencioni B, Magnani B, Reynaerts D, Trivella MG, Pietrabissa A: A Microrobot for colonoscopy. Proc of Seventh Int Symp on Micro Machine & Human Science, IEEE. Pages 223-228, 1996

- ¹⁶ Carroza MC, Dario P, Lencioni B, Magnani B, Reynaerts D, Trivella MG, Pietrabissa A: A Microrobot for colonoscopy. Proc of Seventh Int Symp on Micro Machine & Human Science, IEEE. Pages 223-228, 1996
- ¹⁷ Dario P, Carroza MC, Lencioni B, Magnani B, D'Attanasio S: A miniature robotic system for teleoperated colonoscopy. Proc of IARP Workshop on Medical Robotics, Vienna, Oct 1996
- ¹⁸ Burt CAV: Pneumatic rupture of the intestinal canal with experimental data showing the mechanism of perforation and the pressure required. Arch Surg 22:875-902, 1931
- ¹⁹ Morris AJ, MacKenzie JF: Small-bowel enteroscopy and NSAID ulceration. *Lancet* 1991 Jun 22;337(8756):1550, 1991
- ²⁰ Carroza MC, Dario P, Lencioni B, Magnani B, Reynaerts D, Trivella MG, Pietrabissa A: The development of a microrobot system for colonoscopy. Edited by Troccaz J, Grimson E, Mosges R. Proc of 1st Joint Conf Computer Vision, Virtual Reality & Robotics in Med & Med Rob & Comp Assisted Surgery, Grenoble March 1997. Springer. Pages 779-788, 1997
- ²¹ (Life Nature Library 1964
- ²² Sturges RH, Laowattana S: A flexible tendon-controlled device for endoscopy. Proc 1991 IEEE Int Conf on Rob & Automation, Sacramento: 2582 – 2591, 1991
- ²³ Liming Gao, Liangming L, Guozheng Y, Rong R. *Chinese J of Biomedical Eng*, 1998 Jan (1) 7 pages.
- ²⁴ Ikuta K, Masahiro T, Hirose S: Shape memory alloy servo actuator system with electric resistance feedback and application for active endoscope. IEEE int conf on Robotics and Automation: 427-430, 1988
- ²⁵ Shan Y, Koren Y: Design and motion planning of a mechanical snake. IEEE Trans on systems, man, and cybernetics. 23,4:1091-1100, 1993
- ²⁶ Utsugi M: Tubular medical instrument having a flexible sheath driven by a plurality of cuffs. US patent 4,148,307. 1979
- ²⁷ Krauter AI: Walking borescope. US patent 4,934,786. 1990
- ²⁸ Allred JB III: Self advancing endoscope. US patent 5,345,925. 1994
- ²⁹ Treat MR, Trimmer WS: Self propelled endoscope using pressure driven linear actuators. US patent 5,595,565. 1997
- ³⁰ Goh P, Tekant Y, Krishnan SM: Future developments in high technology surgery: ultrasound, stereo imaging, robotics. *Bailliere's Clinical Gastroenterology*; 7:961-987, 1993
- ³¹ Ginsburgh I, Carlson JA, Taylor GL, Saghatchi H: Method and apparatus for fluid propelled borescopes. US patent 4,735,501. 1988
- ³² Goh P, Krishnan SM. *Micromachines in endoscopy. Bailliere's Clin Gastroenterology*, 1999;13(1), 49-58.
- ³³ Takada M: Self propelled colonoscope. US patent 5,562,601. 1996
- ³⁴ Hibino H, Nagayami Y, Yoshikawa M, Takara T, Goto M, Suzuki A, Takehana S, Hoshimitsu K, Aoki Y, Ueda Y, Matsui R: Endoscope Apparatus. US patent 5,060,632. 1991
- ³⁵ Masuda S: Apparatus for feeding a flexible tube through a conduit. UK patent 1,534,441. 1978
- ³⁶ Shook DR, Doppman JL, Cattau EL, Goldstein SR: Everting (toposcopic) catheter for broad clinical application. *Trans ASME, J Biomech Eng* 108:168-174 1986
- ³⁷ Benjamin BS, Collins KS: The toposcopic everting through-lumen catheter to facilitate dilation of severe strictures of the GI tract. *GI Endosc* 32: 33-35 1986
- ³⁸ Bauer O, Diedrich D, Bacich S, Knight C, Lowery G, van der Ven H, Werner A, Krebs D. Transcervical access and intraluminal imaging of the Fallopian tube in the non anaesthized patient. Preliminary results using a new technique for fallopian access. *Human Reproduction* 7 suppl 1:7-11
- ³⁹ Grundl A, Bob A, Bob K. Method and apparatus for moving an endoscope along a canal shaped cavity. US patent 5,586,968. 1996.
- ⁴⁰ Meron G. Given Imaging Ltd, Yoqneam, Israel. Personal communication, June 1999.
- ⁴¹ Swain CP, Gong F, Mills TN: Wireless transmission of a colour television moving image from the stomach using a miniature CCD camera, light source and microwave transmitter. *Gastrointest Endosc* 45:AB40. 1997
- ⁴² Iddan GJ, Sturlesi D: In vivo video camera. US patent 5,604,531. 1997
- ⁴³ Report from Washinton School of Medicine, St Louis MO 63108-2259. Available via <http://www.stereotaxis.com/> December 1998.
- ⁴⁴ McNeil RG, Ritter RC, Wang B, Lawson MA, Gillies GT, Wika KG, Quate EG, Howard MA, Grady MS. Functional Design Features and Initial Performance Characteristics of a Magnet-Implant Guidance System for Stereotactic Neurosurgery. *IEEE Trans Biomed Eng* 42, no 8, Aug 1995, 793-799.

- ⁴⁵ Howard MA, Grady MS, Ritter RC, Gillies GT, Broaddus WC, Dacey RG. Magnetic Neurosurgery. *Stereotact Funct Neurosurg* 1996;66(1-3):102-7.
- ⁴⁶ Blezek DJ, Robb RA. Evaluating virtual endoscopy for clinical use. *J Digit Imaging* 10: Suppl 1 -51-5, 1997
- ⁴⁷ Vining DJ. Virtual colonoscopy. *Gastrointest Endosc Clin N Am* 7:285-291, 1997
- ⁴⁸ Ahlquist DA, Hara AK, Johnson CD. Computed tomographic colography and virtual colonoscopy. *Gastrointest Endosc Clin N Am* 1997, 7:349-5
- ⁴⁹ Bauerfiend P, Luboldt W, Debatin JF. Virtual Colanography. *Bailliere's Clinical Gastroenterology*, 1999;13(1), 59-65.
- ⁵⁰ Nagel JG. Extension pull through device to allow for easier passage of flexible fiber endoscope. US patent 4,066,071. 1978.

References for Chapter 3

- ¹ Tada M, Iso A, Ohtsuka H, Ogawa M, Shimizu S, Aoki Y, Aoike A, Kawai K. Clinical evaluation of a newly designed small caliber scope in pediatric colonoscopy. *Gastroenterological Endoscopy*, 31(4) 918-923 April 1989.
- ² Woloshynowych M. Psychological preparation for Gastrointestinal endoscopy. PhD Thesis, Dep't of Psychology, UCL, London University. 1997.
- ³ Mosse CA, Mills TN, Bell GD, Swain CP. Forces exerted during oesophageal dilatation. *Gastrointest Endosc* 1997;45:AB75
- ⁴ Mosse CA, Mills TN, Bell GD, Swain CP: Device for measuring the forces exerted on the shaft of an endoscope during colonoscopy. *Med & Biol Eng & Comp*, 36:186-191, 1998
- ⁵ Bladen J.S, Anderson A.P., Bell G.D., Rameh B., Evans B., Heatley D.J.T. Non-radiological technique for three dimensional imaging of endoscopes. *The Lancet* 341, 719- 722, 1993.
- ⁶ Williams CB, Saunders BP, Bell GD, Bladen JS, Gillies DF, Guy CM. Real-time magnetic three-dimensional imaging of flexible endoscopy. *Gastrointest Endosc Clin N Am* Jul;7(3):469-475, 1997

References for Chapter 4

-
- ¹ DennyMW. Air and water, the biology and physics of life's media. Princeton University Press, 1993, Princeton NJ. P 45.
 - ² Ginsburgh I, Carlson JA, Taylor GL, Saghatchi H: Method and apparatus for fluid propelled borescopes. US patent 4,735,501. 1988
 - ³ Pnuelli and Gutfinger. *Fluid Mechanics*. Cambridge University Press, Cambridge 1992. Chapter 4
 - ⁴ King RC. *Piping Handbook*, 5th Edition, McGraw Hill Book Company, New York, 1967, p.3-26.
 - ⁵ Schlichting H, *Boundary-Layer Theory*, 7th Ed, McGraw-Hill, New York 1979. (Cited in ¹).
 - ⁶ Kaye GWC, Laby TH. *Tables of physical and chemical constants*, 15th Ed. Longmans, Harlow, 1986.
 - ⁷ Burt CAV. Pneumatic rupture of the intestinal canal with experimental data showing the mechanism of perforation and the pressure required. *Archives of Surgery*, Vol 22, No 6, 875-902, June 1931.
 - ⁸ Williams CB, Lane R, Sakai Y, Hanwell A. Air pressure hazard during colonoscopy. *Lancet* 11, 729, 1973
 - ⁹ Razzak IA, Millan J, Schuster MM. Pneumatic ileal perforation: an unusual complication of colonoscopy. *Gastroent*. 70:268-71 1976.
 - ¹⁰ Wu TK. Occult injuries during colonoscopy. *GI Endosc*. 24 no 5,236-8 1978.
 - ¹¹ Sjogren TK, Johnson LF, Butler ML, Gremillion DE, Cammerer RC, Heit HA. Serosal laceration: a complication of intra-operative colonoscopy explained by transmural pressure gradients. *GI Endosc*. 24 no 5,239-242. 1978
 - ¹² Kozarek RA, Earnest DL, Silverstein ME, Smith RG. Air pressure induced colon injury during diagnostic. *Gastroent*. 78/1, 7-14 1980.
 - ¹³ Brakyo T, Kozarek RA, Sanowski RA, Howells T. Diverticular rupture during colonoscopy. *Dig Dis Sci*, 29:427-431 1985.

-
- ¹⁴ Orsoni P, Berdah S, Verrier C, Caamano A, Sastre B, Routboul R, Grimaud JC, Picaud R. Colonic Perforation Due to Colonoscopy: A retrospective Study of 48 Cases. *Endoscopy*; 29: 160-164. 1997.
- ¹⁵ Damore LJ, Rantis PC, Vernava AM, Longo WE. Colonoscopic Perforations; Etiology, Diagnosis, and Management. *Dis Colon Rectum*; 39 No 11, 1308-1314, 1996.
- ¹⁶ Young WC. *Roark's Formulas for Stress and Strain*, 6th Ed. McGraw Hill International Editions, Singapore, 1989
- ¹⁷ Yamada H. *Strength of Biological Materials* (ed. F Gaynor Evans). Robert E Kreiger Publishing Co. New York 1973.
- ¹⁸ Burt CAV. Pneumatic rupture of the intestinal canal with experimental data showing the mechanism of perforation and the pressure required. *Archives of Surgery*, Vol 22, No 6, Table 1, Page 80-81, June 1931.
- ¹⁹ Kozarek 1980. *Ibid*.
- ²⁰ Bayvel L and Orzechowski Z. *Liquid atomisation*. Taylor Francis, Bristol PA 1993, page 7.
- ²¹ Bayvel L *Ibid* page 37
- ²² Heschel M, Mullenborn M, Bouwstra S. Fabrication and characterization of truly 3-D diffuser/nozzle microstructures in silicon. *J. of Micro-electromechanical Systems* 6, 1, 41-47. 1997

References for Chapter 5

- ¹ Dario P, Carroza MC, Lencioni B, Magnani B, D'Attanasio S: A miniature robotic system for teleoperated colonoscopy. *Proc of IARP Workshop on Medical Robotics*, Vienna, Oct 1996
- ² Burt CAV: Pneumatic rupture of the intestinal canal with experimental data showing the mechanism of perforation and the pressure required. *Arch Surg* 22:875-902, 1931
- ³ Kadirkamanathan SS, Evans DF, Gong F, Yazaki E, Scott M, Swain CP. Antireflux operations at flexible endoscopy using endoluminal stitching techniques: an experimental study. *Gastrointest Endosc*. 1996 Aug;44(2):133-43.
- ⁴ Gong F. Design, development and testing of miniature instruments for flexible endoscopy. Page 184. PhD thesis submitted to the University of London, February 1999.
- ⁵ Phee SJ, Ng WS, Chen IM, Seow-Choen F, Davies BL. Automation of colonoscopy. Part II: Visual-control aspects. *IEEE Eng Med Biol Mag*. 1998 May-Jun;17(3):81-8.
- ⁶ Carroza MC, Dario P, Lencioni B, Magnani B, D'Attanasio S, Trivella MG, Pietrabissa A. The development of a microrobot system for colonoscopy. Edited by Troccaz J, Grimson E, Mosges R. 1st Joint Conf Computer Vision, Virtual Reality & Robotics in Med & Med Rob & Comp Assiste Surgery, Grenoble March 1997 Springer, 1997
- ⁷ Dario Paolo (It); Carrozza Maria Chiara (It); Pietrabissa Andrea (It); Magnani Bernardo (It); Lencioni Lucia (It). Endoscopic robot Requested Patent: EP0838200 A 19980429. Publication date: 1998-04-29
- ⁸ Stress and strain
- ⁹ Schlichting H, *Boundary-Layer Theory*, 7th Ed, McGraw-Hill, New York 1979. (Cited in ¹).
- ¹⁰ Drapier, Van Steenbrugge et Breton. *Perfectionnements aux cathéters médicaux*. P.V. no 850.935 No 1.278.965. Paris, 1961.
- ¹¹ Franks T. Personal communication reported by Dr F Gong. 1999.

References for Chapter 6

- ¹ Jones BE. *The Amateur Mechanic, A practical guide for the handyman*. Vol 4. Waverly Book Co, London. Pre 1920.
- ² McGeown JG. *Physiology. A core text of human physiology with self assessment*. Churchill Livingstone, Edinburgh. 1996.
- ³ Jiri Koryta. *Ions, electrodes and membranes*. John Wiley and sons Ltd., Chichester. 1982.
- ⁴ Britannica CD 98. *Enclopaedia Britannica Inc., Cicago IL, USA*. 1998
- ⁵ Patterson B. <http://research.biology.arizona.edu>, *The Biology Project at The University of Arizona* 1997
- ⁶ Eagon JC, Kelly KA. Effects of gastric pacing on canine gastric motility and emptying. *Am J Physiol*. 1993 Oct;265(4 Pt 1):G767-74
- ⁷ Struchfield B. The electrically stimulated neoanal sphincter and colonic conduit. *Br J Nurs*. 1997 Feb 27-Mar 12;6(4):219-24. Review
- ⁸ Williams NS, Hallan RI, Koeze TH, Watkins ES. Restoration of gastrointestinal continuity and continence after abdominoperineal excision of the rectum using an electrically stimulated neoanal sphincter. *Dis Colon Rectum*. 1990 Jul;33(7):561-5 Hughes SF, Scott SM, Pilot MA, Williams NS.
- ⁹ Shatari T, Sugiyama Y, Teramoto T, Kitajima M, Minamitani H. Reconstruction of anal function by transposed gracilis muscle with electrical stimulation: rabbit model. *Int J Artif Organs*. 1994 Apr;17(4):240-4.
- ¹⁰ Mander BJ, Abercrombie JF, George BD, Williams NS. The electrically stimulated gracilis neosphincter incorporated as part of total anorectal reconstruction after abdominoperineal excision of the rectum. *Ann Surg*. 1996 Dec;224(6):702-9; discussion 709-11
- ¹¹ Ratani RS, Yazaki E. Electrically stimulated smooth muscle neosphincter. *Br J Surg*. 1997 Sep;84(9):1286-9.
- ¹² Hughes SF, Scott SM, Pilot MA, Williams NS. Electrically stimulated colonic reservoir for total anorectal reconstruction. *Br J Surg* 1995 Oct;82(10):1321-6
- ¹³ Grundfest-Broniatowski S, Moritz A, Ilyes L, Jacobs G, Kasick J, Olsen E, Nose Y. Voluntary control of an ileal pouch by coordinated electrical stimulation. A pilot study in the dog. *Dis Colon Rectum*. 1988 Apr;31(4):261-7.
- ¹⁴ Moritz A, Grundfest-Broniatowski S, Ilyes L, Kasick J, Jacobs G, Olsen E, Nose Y. Electrical pulse train and single pulse stimulation of the small intestine: acute and chronic studies in the dog. *Artif Organs*. 1989 Apr;13(2):116-22
- ¹⁵ Moritz A, Grundfest-Broniatowski S, Ilyes L, Kasick J, Jacobs G, Nose Y. Contractile response to electrical stimulation of the small intestine in anesthetized and awake dogs. *Artif Organs*. 1989 Dec;13(6):553-7.
- ¹⁶ Scott M. Verbal communication. June 1999. Department of Gastroenterology, Royal London Hospital, Whitechapel, London.
- ¹⁷ Accarino AM, Azpiroz F, Malagelada JR. Selective dysfunction of mechanosensitive intestinal afferents in irritable bowel syndrome. *Gastroenterology* 1995 Mar;108(3):636-43
- ¹⁸ Accarino AM, Azpiroz F, Malagelada JR. Symptomatic responses to stimulation of sensory pathways in the jejunum. *Am J Physiol*. 1992 Nov;263(5 Pt 1):G673-7.
- ¹⁹ Frexinos J, Delvaux M. Colonic Motility. In 'An illustrated guide to colonic motility', edited by Kumar D, Wingate D. Second edition, Churchill Livingstone, Edinburgh, 1993. Page 429.
- ²⁰ Mosse CA, Swain CP. Technical Advances and experimental devices for enteroscopy. *Gastrointestinal Clinics of North America*. 1999, 9,1 145-161,

References to Chapter 7

- ¹ Uyama Y, Tadokoro H, Ikada Y. Low-frictional catheter materials by photo-induced graft polymerization. *Biomaterials* 1991 Jan;12(1):71-75
- ² LaPorte RJ. Hydrophilic polymer coatings for medical devices. Technomic Publishing, Lancaster PA, USA. Page 21.
- ³ Ikada Y. Surface modification of polymers for medical applications. *Biomaterials*; 1994, 15(10):725-736
- ⁴ Ibid 2 above, page 34.
- ⁵ Conroy S. Aqueous Based Lubricious Coating Technology *Med Device Tech*, Oct 1998 9(8);20-36
- ⁶ Fujimoto K, Takebayashi Y, Inoue H, Ikada Y. Ozone induced graft polymerisation onto polymer surface. *J Polymer Sci. Part A, Poly Chem*. 1993 31(4);1035-43
- ⁷ Nagaoka S, Akimasa N Clinical Application of antithrombogenic hydrogel with polyethylene oxide chains. From High Performance biomaterials. Ed Szycher. Technomic Publishing, Lancaster PA, USA. 1991, page 401.
- ⁸ Marmieri G, Pettenati M, Cassinelli C, Morra M. Evaluation of slipperiness of catheter surfaces. *J. Biomaterials Res (Applied Biomaterials)*, 1996 33, 29-33
- ⁹ Caravia L, Dowson D, Fisher J, Corkhill PH, Tighe BJ. Friction of hydrogel and polyurethane elastic layers when sliding against each other under a mixed lubrication regime. *Wear*, 1995 181-183; 236-240
- ¹⁰ Nickel JC, Olson ME, Costerton JW. In vivo coefficient of kinetic friction: study of urinary catheter biocompatibility. *Urology* 1987 May;29(5):501-503
- ¹¹ Tomita N, Tamai S, Okajima E, Hirao Y, Ikeuchi K, Ikada Y. Biomaterials lubricated for minimum frictional resistance. *J. Applied Biomaterials*, 1994 5;175-181.
- ¹² Silverstein F et al. Protective endoscope sheath and method of installing same. 1987 US patent 4,646,722
- ¹³ Moriyama H. Cover sheathed endoscope. 1997 US patent 5,695,449 Assigned to Olympus.
- ¹⁴ Beamis JF, Mathur PM, H Colt, J Harrell. Clinical evaluation of the Vision Sciences flexible bronchoscope and Endosheath system. *Chest* 1997;112(3S):60
- ¹⁵ Sardinha TC, Wexner SD, Gilliland J, Daniel N, Kroll M, Lee E, Wexler J, Hudzinski D, Glass D. Efficiency and productivity of a sheathed fiberoptic sigmoidoscope compared with a conventional sigmoidoscope. *Dis Colon Rectum* 1997 Oct;40(10):1248-53
- ¹⁶ Rothstein RI, Littenberg B. Disposable, sheathed, flexible sigmoidoscopy: a prospective, multicenter, randomized trial. The Disposable Endoscope Study Group. *Gastrointest Endosc* 1995 Jun;41(6):566-72
- ¹⁷ Caravia L, Dowson D, Fisher J, Corkhill PH, Tighe BJ. Friction of hydrogel and polyurethane elastic layers when sliding against each other under a mixed lubrication regime. *Wear* 1995, 181-183; 236-240

References to Appendix 1

- ¹ Cotton PB, Williams CB. Practical Gastrointestinal Endoscopy, 4th Edition, Blackwell Science, Oxford, 1966.
- ² Technical status evaluation report on endoscopy simulators. The American Society for Gastrointestinal Endoscopy (ASGE), May 1999.
- ³ Carroza MC, Dario P, Lencioni B, Magnani B, D'Attanasio S, Trivella MG, Pietrabissa A. The development of a microrobot system for colonoscopy. Edited by Troccaz J, Grimson E, Mosges R. 1st Joint Conf Computer Vision, Virtual Reality & Robotics in Med & Med Rob & Comp Assiste Surgery, Grenoble March 1997 Springer, 1997
- ⁴ Hochberger J, Neumann M, Maiss J, Hohenberger W, Hahn EG. EASIE - Erlangen active simulator for interventional endoscopy - A new bio-simulation-model - First experiences gained in training workshops. *GI Endosc*, 1998, Vol.47, No.4 SS, p.370
- ⁵ Hochberger J, Maiss J, Hildebrand V, Bayer J, Hahn EG. MiniEASIE - A new easy to handle and widely available training model for interventional endoscopy. *GI Endosc*. 1999, Vol.49, No.4 Pt2, p.358. Meeting abstract. (Not read by current author)
- ⁶ Frexinos J, Delvaux M. Colonic Motility. Figure 28.1 in Kumar D, Wingate D. An illustrated guide to colonic motility. Second edition. Churchill Livingstone, Edinburgh, 1993.