

Aberystwyth University

Adaptive Fuzzy Interpolation and Extrapolation with Multiple-antecedent Rules

Shen, Qiang; Yang, Longzhi

Published in:

Proceedings of the 19th International Conference on Fuzzy Systems (FUZZ-IEEE'10)

Publication date:

2010

Citation for published version (APA):

Shen, Q., & Yang, L. (2010). Adaptive Fuzzy Interpolation and Extrapolation with Multiple-antecedent Rules. In *Proceedings of the 19th International Conference on Fuzzy Systems (FUZZ-IEEE'10)* (pp. 565-572) <http://hdl.handle.net/2160/4873>

General rights

Copyright and moral rights for the publications made accessible in the Aberystwyth Research Portal (the Institutional Repository) are retained by the authors and/or other copyright owners and it is a condition of accessing publications that users recognise and abide by the legal requirements associated with these rights.

- Users may download and print one copy of any publication from the Aberystwyth Research Portal for the purpose of private study or research.
- You may not further distribute the material or use it for any profit-making activity or commercial gain
- You may freely distribute the URL identifying the publication in the Aberystwyth Research Portal

Take down policy

If you believe that this document breaches copyright please contact us providing details, and we will remove access to the work immediately and investigate your claim.

tel: +44 1970 62 2400
email: is@aber.ac.uk

Adaptive Fuzzy Interpolation and Extrapolation with Multiple-antecedent Rules

Longzhi Yang and Qiang Shen

Abstract—Adaptive fuzzy interpolation strengthens the potential of fuzzy interpolative reasoning owing to its efficient identification and correction of defective interpolated rules during the interpolation process [11]. This approach assumes that: i) two closest adjacent rules which flank the observation or a previously inferred result are always available; ii) only single-antecedent rules are involved. In practice, however, variable values of these rules may lie just on one side of the observation or inferred result. Also, there may be certain rules with multiple antecedents in the rule base. This paper extends the adaptive approach, in order to cover fuzzy extrapolation and to support rule base with multiple-antecedent rules. Adaptive fuzzy interpolation and extrapolation complement each other, which jointly improve the applicability of fuzzy interpolative reasoning, as it significantly reduces the restriction over the given rule base.

I. INTRODUCTION

Fuzzy rule interpolation enhances the robustness of fuzzy reasoning. When given observations have no overlap with any antecedent values, no rule can be fired in classical inference. However, interpolative reasoning through a sparse rule base may still obtain certain conclusions and thus improve the applicability of fuzzy models. Also, with the help of fuzzy interpolation, the complexity of a rule base can be reduced by omitting those fuzzy rules which may be approximated from their neighboring ones. A number of important interpolating approaches have been presented in the literature, including [1], [2], [3], [4], [7], [8], [9], [10]. In particular, the scale and move transformation-based approach can handle both interpolation and extrapolation which involve multiple fuzzy rules, with each rule consisting of multiple antecedents. This approach also guarantees the uniqueness as well as normality and convexity of the resulting interpolated fuzzy sets. Yet, it is possible that more than one object value of a single variable may be derived or observed in fuzzy interpolation. This implies that certain inconsistencies may result.

To address this problem, recently, *adaptive interpolative reasoning* has been proposed [11]. This approach is capable of efficiently detecting inconsistencies, locating possible fault candidates and modifying the candidates in an effort to remove all the inconsistencies. It works by artificially viewing the interpolative inference procedures as system components, and then utilizing an assumption-based truth maintenance system (ATMS) [5] to record the dependencies between an interpolated value (including any contradiction) and its preceding interpolation components. From this, the classical algorithm of general diagnostic engine (GDE) [6] is

Longzhi Yang and Qiang Shen are with the Department of Computer Science, Aberystwyth University, UK (email: {lly07, qqs}@aber.ac.uk).

employed to manipulate the sets of dependent components of contradictions to hypothesize all possible candidates of defective rules.

However, the adaptive approach of [11] is limited in its implementation in that fuzzy models are assumed to involve only single-antecedent rules and to reason only based on neighboring rules which strictly flank the given observation or a previously inferred result. Nevertheless, fundamentally, this is not restricted by the underlying approach. This work extends that of [11], in order to allow for the use of rules with multiple antecedents and to reason based on two rules both of which lie on one side of the observation or the inferred result. This will considerably widen the scope of the existing approach for adaptive fuzzy interpolation. This is because in many practical applications of fuzzy systems, multiple-antecedent rules are common and distributions of rules in a rule base can be very irregular.

The rest of this paper is structured as follows. Sec. II reviews the background of adaptive fuzzy interpolation. Sec. III describes the generalization of the existing approach to allow multiple-antecedent rules and cover fuzzy extrapolative reasoning. Sec. IV gives an example to illustrate the utility of this work. Sec. V concludes the paper and points out important future research.

II. OVERVIEW OF ADAPTIVE INTERPOLATION

Adaptive interpolative reasoning [11] provides a way to ensure inference results being consistent during the fuzzy interpolative process. In implementing fuzzy interpolation, each pair of neighboring rules is defined as a *fuzzy reasoning component* which takes a fuzzy set (an observation or a previously inferred result, which is hereafter referred to as an observation for simplicity) as input and produces another (the consequent of the interpolated rule) as output. The process of adaptive interpolation can be summarized in Fig. 1. Firstly, the interpolator carries out interpolation and passes the interpolated results to the ATMS for dependency-recording. Then, the ATMS relays any β_0 -contradictions (i.e. inconsistency between two different values for a common variable at least to the degree of a given threshold β_0 ($0 \leq \beta_0 \leq 1$)) as well as their dependent fuzzy reasoning components to the GDE which diagnoses the problem and generates all possible component candidates. After that, a modification process takes place to correct a certain candidate to restore consistency. A brief description of each of these key methods is given below.

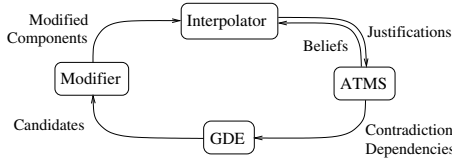

Fig. 1. Adaptive interpolative reasoning

A. Truth maintenance

ATMS is utilized to record the dependency of the interpolated results, including any contradictions, upon those fuzzy reasoning components from which they are inferred. Any ATMS node with an inferred proposition is represented by an ATMS justification:

$$O, R_i R_j \Rightarrow C, \quad (1)$$

where $R_i R_j$ stands for the fuzzy reasoning component containing the two neighboring rules R_i and R_j ($i \neq j$) that have been used to infer the outcome C from the observation O . Accordingly, a β_0 -contradiction is represented as:

$$P, P' \Rightarrow_{\beta_0} \perp. \quad (2)$$

In ATMS terms, a *label* is a set of environments, each supporting the node that it is associated with. An environment contains a minimal set of fuzzy reasoning components that jointly entail the concerned node, thereby describing how the node ultimately depends on those fuzzy reasoning components. An environment is said to be β_0 -inconsistent if β_0 -contradiction is derivable propositionally by the environment and a given justification. An environment is said to be $(1 - \beta_0)$ -consistent if it is not β_0 -inconsistent.

The label of each node is guaranteed to be $(1 - \beta_0)$ -consistent, sound, minimal and complete by the algorithm that ATMS updates node labels, except that the label of the special “false” node is guaranteed to be β_0 -inconsistent rather than $(1 - \beta_0)$ -consistent. In particular, the label of the special “false” node gathers all β_0 -inconsistent environments. Its corresponding label-updating process is given as follows. Whenever a β_0 -contradiction is detected, each environment in its label is added into the label of “false” node and all such environments and their supersets are removed from the label of every other node. Also, any such environment which is a superset of another is removed from the label of the node “false”.

B. Candidate generation

A candidate in GDE [6] is a set of assumptions which may be responsible for the whole set of current contradictions. GDE generates minimal candidates by manipulating the label of the specific “false” node. Because a β_0 -inconsistent environment indicates that at least one of its assumptions is faulty, a candidate must have a nonempty intersection with each β_0 -inconsistent environment. Thus, each candidate is constructed by taking one assumption from each environment in the label of “false” node. Supersets removal then ensures such generated candidates to be minimal. In light of this, a successful correction of any single candidate will remove all the contradictions (see later).

C. Candidate modification

Consistency can be restored by successfully correcting any single candidate because each such candidate explains the entire set of current contradictions. Suppose that $\text{MODIFY}(f)$ is the modification procedure for a given fuzzy reasoning component (f), which returns **true** when the modification succeeds and **false** otherwise. Let \mathbb{Q} be a priority queue whose elements are ordered such that those of the smallest cardinality have the highest priority. Given a set of candidates \mathbb{S} , each of which (C) is a set of fuzzy reasoning components, the modification procedure is shown in Fig. 2.

CONSISTENCYRESTORING(\mathbb{S})

- (1) **foreach** $C \in \mathbb{S}$
- (2) $\mathbb{Q}.Enqueue(C)$
- (3) $success \leftarrow \text{false}$
- (4) **do**
- (5) $C \leftarrow \mathbb{Q}.Dequeue()$
- (6) **foreach** $f \in C$
- (7) $success \leftarrow \text{MODIFY}(f)$
- (8) **if** ($success == \text{false}$)
- (9) **break**
- (10) **until** ($(success == \text{true})$ or $(\mathbb{Q} == \emptyset)$)
- (11) **return** $success$

Fig. 2. The CONSISTENCYRESTORING procedure

For convenience, in the rest of this paper, let A_{ij}^* denote the modified consequent of a culprit interpolated rule whose consequent value is A_{ij} , and $A_{ij}^{*'}$ and λ_{ij}^* denote the corresponding modified intermediate rule consequence and the *relative placement factor* of A_{ij}^* , respectively. Suppose that the neighboring rules $(x_1 = A_{11}) \Rightarrow (x_2 = A_{21})$ and $(x_1 = A_{1n}) \Rightarrow (x_2 = A_{2n})$ are the two rules used by a defective fuzzy reasoning component, that $A_{12}, A_{13}, \dots, A_{1(n-1)}$ are observations located between A_{11} and A_{1n} , and that A_{1j} ($2 \leq j \leq n-1$) is the middle most one. In carrying out interpolation, the presumed linear relation between an antecedent variable and the corresponding consequent variable can be represented by a line segment which starts from (A_{11}, A_{21}) and ends by (A_{1n}, A_{2n}) in the x_1, x_2 -plane. The modification breaks this straight line segment into two connected straight line segments: one from (A_{11}, A_{21}) to (A_{1j}, A_{2j}) and the other from (A_{1j}, A_{2j}) to (A_{1n}, A_{2n}) . That is, it uses a first-order piecewise linear approximation to replace the original linear method. The modification procedure for a single fuzzy reasoning component is summarized as follows.

1. Find the rule $(A_{1j} \Rightarrow A_{2j})$ whose antecedent locates in the middle most of the neighborhood of the antecedents of any two rules that may be used for interpolation, with respect to their representative values. Assume that the *relative placement factor* of its consequence λ_{2j} is modified to λ_{2j}^* .

2. Calculate the *correction rate pair* according to the *relative placement factor* modification of rule $A_{1j} \Rightarrow A_{2j}$:

$$\begin{cases} c^- = \frac{\lambda_{2j}^*}{\lambda_{2j}} \\ c^+ = \frac{1 - \lambda_{2j}^*}{1 - \lambda_{2j}} \end{cases} \quad (3)$$

3. Calculate the modified *relative placement factors* of consequences of all other interpolated rules which are generated from the same defective fuzzy reasoning component as per the *correction rate pair* computed above, where $i \in \{2, 3, \dots, j-1\}$ and $k \in \{j+1, j+2, \dots, n-1\}$:

$$\begin{cases} \lambda_{2i}^* = \lambda_{2i} \cdot c^- \\ 1 - \lambda_{2k}^* = (1 - \lambda_{2k}) \cdot c^+ \end{cases} \quad (4)$$

4. Calculate the modified consequences of all interpolated rules which are generated from the same defective fuzzy reasoning component in accordance with their modified *relative placement factors*:

$$\begin{cases} A_{2x}^*{}' = (1 - \lambda_{2x}^*)A_{21} + \lambda_{2x}^*A_{2n} \\ T(A_{1x}^*{}', A_{1x}) = T(A_{2x}^*{}', A_{2x}^*), \end{cases} \quad (5)$$

where $x \in \{2, 3, \dots, n-1\}$, and $T(A', A)$ represents scale and move transformations from fuzzy set A' to A .

5. Restrict the modified consequence to be consistent with the context. Suppose that m object values $A_{i1}, A_{i2}, \dots, A_{im}$ are obtained for variable x_i . If they are $(1 - \beta_0)$ -consistent, they must satisfy:

$$\bigcap_{j=1}^m (A_{ij})_{\beta_0} \neq \emptyset, \quad (6)$$

where $(A_{ij})_{\beta_0}$ denotes the β_0 -cut of fuzzy set A_{ij} .

6. Restrict the propagations of all modified consequences to be consistent with the context. For simplicity, let function $I(A_{ij}, R_l R_r) = A_{kj}$ denote the standard interpolation from the antecedent fuzzy set A_{ij} to the consequent value A_{kj} , based on fuzzy reasoning component $R_l R_r$. Suppose that m object values $A_{i1}, A_{i2}, \dots, A_{im}$ of variable x_i are modified which are located between the antecedent values of rules R_l and R_r , that the corresponding modified object values of variable x_k are A_{kj}^* , $j \in \{1, 2, \dots, m\}$, and that n object values A_{kl} , $l \in \{1, 2, \dots, n\}$, of variable x_k are already obtained one way or another. If the modified consequences A_{kj}^* are all $(1 - \beta_0)$ -consistent, then they must satisfy:

$$\begin{cases} A_{kl}^* = I(A_{ij}^*, R_l R_r) \\ \left(\bigcap_{j=1}^m (A_{kj}^*)_{\beta_0} \right) \cap \left(\bigcap_{l=1}^n (A_{kl})_{\beta_0} \right) \neq \emptyset. \end{cases} \quad (7)$$

7. Solve all these simultaneous equations as generated above. The result is the modified solution which ensures inconsistency-free.

III. EXTENSIONS

The approach described above assumes that each rule in the rule base involves only one antecedent variable. Also, the two closest adjacent rules must flank the observation. These limitations inevitably restrict the potential application of the existing techniques. However, the present approach is readily extendable to deal with these situations. Thus, the work [11] is extended herein to allow both interpolation and extrapolation with rules that involve multiple-antecedent attributes.

A. Interpolation with multiple-antecedent rules

If only one antecedent is involved in each rule in the rule base, given an observation, it is straightforward to find the flank rules to fire in the rule base. However, when multiple conditional variables are involved, the situation is rather different. It is too restrict to find such a pair of rules that every pair of their counterpart antecedents flanks the corresponding term of the observation, also in the same order. In order to remove such limitations, two closest rules rather than strictly two flanked rules are employed for multiple-antecedent rule interpolation. Once the two closest rules are chosen, the intermediate rule can then be constructed. From this, the resultant fuzzy set can be transformed from the consequent of the intermediate rule. The procedures of how to achieve these are briefly outlined as follows:

1. Choose the closest two rules: Without losing generality, suppose that a rule and an observation are represented by:

Rule R_i : If x_1 is A_{1i}, \dots, x_m is A_{mi} , then x_n is A_{ni} (8)

Observation: x_1 is A_{1x} and ... and x_m is A_{mx} . (9)

According to the work in [7], the distance $d(A_{ki}, A_{kx})$ ($k \in \{1, 2, \dots, m\}$) between two fuzzy sets A_{ki} and A_{kx} can be calculated by:

$$d_k = d(A_{ki}, A_{kx}) = d(\text{Rep}(A_{ki}), \text{Rep}(A_{kx})), \quad (10)$$

where $\text{Rep}(A_{ki})$ and $\text{Rep}(A_{kx})$ are the representative values of fuzzy sets A_{ki} and A_{kx} , respectively. As attributes have different domains, the absolute distances may not be compatible with each other. Therefore, a normalized distance measure (range of 0 to 1) is defined by:

$$d'_k = \frac{d(A_{ki}, A_{kx})}{\max_k - \min_k} = \frac{d(\text{Rep}(A_{ki}), \text{Rep}(A_{kx}))}{\max_k - \min_k}, \quad (11)$$

where \max_k and \min_k are the maximal and minimal values in the domain of attribute k , respectively. The distance d between the antecedents of a rule and an observation can be calculated in accordance with the weights of the antecedent attributes. If all attributes are of the same importance, the distance d is defined as the average of its all normalized attributes' distances:

$$d = \sqrt{d_1'^2 + d_2'^2 + \dots + d_m'^2}. \quad (12)$$

With the above definition, the distances between a given observation and the antecedent values of all those rules which involve the same antecedent attributes in the rule base can be calculated. The two rules which have minimal distances are chosen as the closest two rules from the observation. Note that each pair of antecedent values of the two closest rules does not necessarily flank its corresponding term in the observation. In the extreme case, all the conditional attribute values of the two closest rules may locate in one side of the given observation, resulting in extrapolation rather than interpolation (see Sec. III-B).

2. Construct the intermediate rule: Having chosen the two closest rules, the next step is to construct the intermediate

rule. Suppose that rules R_i and R_j are the two closest rules for a given observation:

If x_1 is A_{1i} and ... and x_m is A_{mi} , then x_n is A_{ni} ;
 If x_1 is A_{1j} and ... and x_m is A_{mj} , then x_n is A_{nj} .

When an observation $(A_{1x}, A_{2x}, \dots, A_{mx})$ is given, by analogy to the single antecedent case, the object values A_{ki} and A_{kj} ($k \in \{1, 2, \dots, m\}$) of antecedent variable x_k of those two rules are used to obtain the new intermediate fuzzy set A'_{kx} :

$$A'_{kx} = (1 - \lambda_{kx})A_{ki} + \lambda_{kx}A_{kj}, \quad (13)$$

where λ_{kx} is the *relative placement factor* associated with the value A_{kx} of the k th antecedent variable, that is:

$$\lambda_{kx} = \frac{d(A_{ki}, A_{kx})}{d(A_{ki}, A_{kj})}. \quad (14)$$

It can be shown that the representative value of A'_{kx} remains the same as that of A_{kx} . From this, the *relative placement factor* λ_{nx} of the consequent is computed by the average of λ_{kx} :

$$\lambda_{nx} = \frac{1}{m} \sum_{k=1}^m \lambda_{kx}. \quad (15)$$

Then the consequent of the intermediate rule is calculated by:

$$A'_{nx} = (1 - \lambda_{nx})A_{ni} + \lambda_{nx}A_{nj}. \quad (16)$$

3. Scale and move transformations: The main issue that remains is how to calculate the transformation rates after the intermediate rule has been constructed. The scale rate s_{kx} and move rate m_{kx} of each term A_{kx} of the observation and its corresponding fuzzy set A'_{kx} in the intermediate rule can be calculated in a way which is exactly the same as that of single-antecedent rule interpolation. From this, the combined scale rate s_{nx} and move rate m_{nx} over the m conditional attributes are calculated as the arithmetic averages of s_{kx} and m_{kx} , $k \in \{1, 2, \dots, m\}$:

$$s_{nx} = \frac{1}{m} \sum_{k=1}^m s_{kx}, \quad (17)$$

$$m_{nx} = \frac{1}{m} \sum_{k=1}^m m_{kx}. \quad (18)$$

Note that, other than using arithmetic average, different methods such as the medium value operator or weighted average operator may be employed for this purpose. Once the *scale rate* and *move rate* of the consequent are worked out, the rest of the interpolation process remains the same as that of single-antecedent rule interpolation, which is omitted here due to space limit.

These transformations can be concisely represented by an integrated transformation function T such that the transformation from $(A_{1x}', \dots, A_{mx}')$ to (A_{1x}, \dots, A_{mx}) is denoted by $T((A_{1x}', \dots, A_{mx}'), (A_{1x}, \dots, A_{mx}))$. Note that the combined scale rate s_{nx} and move rate m_{nx} reflect the similarity degree between the observation and the antecedent values

of the intermediate interpolated rule. The fuzzy set A_{nx} of the conclusion can then be estimated by transforming the consequent A'_{nx} of the intermediate interpolated rule via the application of the same s_{nx} and m_{nx} . Thus, the resultant fuzzy set A_{nx} can be transformed from its intermediate rule consequent by the same transformation function:

$$T(A_{nx}', A_{nx}) = T((A_{1x}', \dots, A_{mx}'), (A_{1x}, \dots, A_{mx})). \quad (19)$$

B. Fuzzy extrapolation

The extension of the above to perform extrapolation is readily attainable. Computationally, it can be treated as a special case of fuzzy interpolation. Indeed, when all the object values of the conditional variables of the two closest rules lie on just one side of the given observation, the interpolation problem becomes extrapolation. However, other than such a strict extrapolation case, the problem becomes somewhat more complex when certain antecedent values lie between the two closest rules while the others lie on one side or another. Nevertheless, both choosing the closest rules and constructing the intermediate rules for these situations are carried out in exactly the same way as it for interpolation as described in the above subsection.

C. Truth maintenance and candidate generation

In order for the adaptive approach to handle interpolation based on rules with multiple antecedents, the concept of *fuzzy reasoning component* therefore is generalized as shown in Fig. 3. Here, Rules i and j are the two closest ones to the ob-

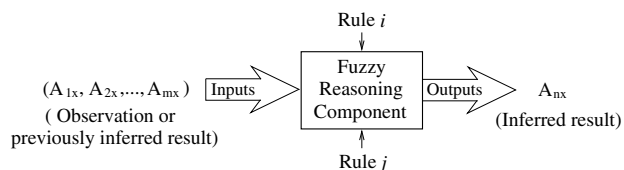

Fig. 3. Fuzzy reasoning component

servation $(A_{1x}, A_{2x}, \dots, A_{mx})$ according to the distance measure given in Eq. 12, and A_{nx} is the inferred result based on these two rules from the observation. The truth maintenance and minimal candidate generation procedures of adaptive fuzzy interpolation/extrapolation with multi-antecedent rules are basically the same as the one used for fuzzy interpolation with single-antecedent rules. The difference only exists in the representation of fuzzy reasoning component. Thus they are omitted here (refer to Sec. II or [11] for details).

D. Candidate modification

The consistency-restoring algorithm outlined in Fig. 2, which is used for single-antecedent rule interpolation can also be used in principle, for multiple-antecedent interpolation with the generalized fuzzy reasoning component. However, it is not straightforward when it comes to the correction procedure for individual defective *fuzzy reasoning component* in a multiple-antecedent rule environment. There are more sophisticated situations which complicate the

choosing procedure of the first rule to modify and thereby the *correction rate* pair. In particular, three cases need to be considered: i) strict interpolation, that is all observations lie on between the two rules; ii) strict extrapolation, that is all observations lie on one side or another but not in between; iii) mixed interpolation and extrapolation, that is observations may lie anywhere, but not as cases i and ii.

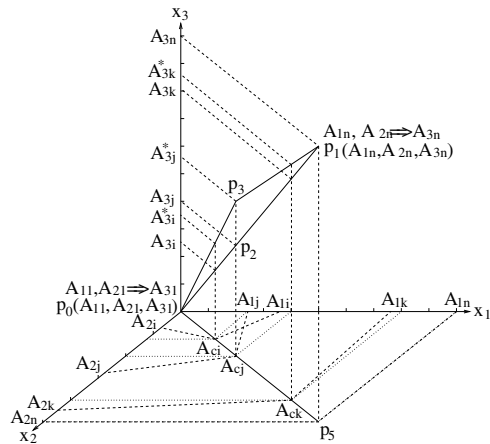

Fig. 4. Defective fuzzy reasoning component modification for interpolation

The problem space of n -antecedent ($n \geq 1$) rule interpolation is $(n + 1)$ -dimensional. Without losing generality, for simplicity, two-antecedent rules are taken here as an example. Suppose that $(A_{12}, A_{22}), (A_{13}, A_{23}), \dots, (A_{1(n-1)}, A_{2(n-1)})$ are observations, and that the neighboring rules $A_{11}, A_{21} \Rightarrow A_{31}$ and $A_{1n}, A_{2n} \Rightarrow A_{3n}$ are the two closest rules to these observations. It is interesting to observe that in computing interpolation involving two antecedent variables, the presumed linear relation between the antecedent variables and the corresponding consequent variable can be represented by a line in a 3-dimensional space (line P_0P_1 in Fig. 4) if fuzzy sets are represented using their representative values. Line P_0P_5 , the projection of line P_0P_1 onto plane x_1x_2 , provides a partial order of all possible antecedent value pairs of variables x_1 and x_2 by mapping them onto line P_0P_5 . In particular, as shown in Fig. 4, it has mapped observations $(A_{1i}, A_{2i}), (A_{1j}, A_{2j})$ and (A_{1k}, A_{2k}) to points A_{ci}, A_{cj} and A_{ck} , respectively, on the line P_0P_5 . This is done by the combined *relative placement factor* λ_{3x} ($x \in \{2, 3, \dots, n - 1\}$) calculated from λ_{1x} and λ_{2x} (Eq. 15). Note that it is not necessary that $A_{1i} \leq A_{1j} \leq A_{1k}$ and $A_{2i} \leq A_{2j} \leq A_{2k}$ though $A_{ci} \leq A_{cj} \leq A_{ck}$.

Suppose that A_{cj} ($2 \leq j \leq n - 1$) sits in the middle most within all the observations on the line P_0P_5 . Then, interpolated rule $A_{1j}, A_{2j} \Rightarrow A_{3j}$ will be modified first. The modification breaks the straight interpolation line P_0P_1 into two connected straight line segments P_0P_3 and P_3P_1 as illustrated in Fig. 4. The effect of this proposed modification method is to refine the defective fuzzy reasoning component by dividing it into two more accurate fuzzy reasoning components. This corresponds to refining the fuzzy reasoning component represented by P_0P_1 into two represented by

P_0P_3 and P_3P_1 . All interpolated rules based on the original defective fuzzy reasoning component need to be modified by the two replacement fuzzy reasoning components.

In order to facilitate the modification from the result of the original defective fuzzy reasoning component to the result of either of the new two replacements, a pair of *correction rates* are defined as follows:

$$\begin{cases} c^- = \frac{\lambda_{2j}^*}{\lambda_{2j}} \\ c^+ = \frac{1 - \lambda_{2j}^*}{1 - \lambda_{2j}} \end{cases} \quad (20)$$

where c^- represents the modification rate of those interpolated rules whose antecedents are less than the antecedent of the first modified rule (i.e. (A_{1j}, A_{2j})) by the partial order, and c^+ represents the same meaning for the greater ones. In other words, c^- measures the difference of the interpolated results by interpolation lines P_0P_1 and P_0P_3 from those antecedent pairs which are greater than (A_{11}, A_{21}) and less than (A_{1j}, A_{2j}) according to the partial order, while c^+ does the same but by interpolation lines P_0P_1 and P_3P_1 from those pairs which are between (A_{1j}, A_{2j}) and (A_{1n}, A_{2n}) .

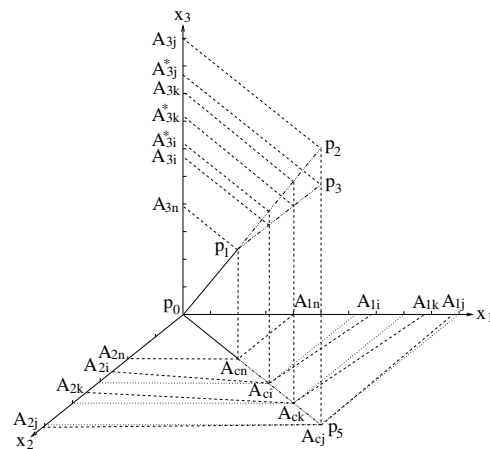

Fig. 5. Defective fuzzy reasoning component modification for extrapolation

The case discussed above covers the first kind of distribution of observations. For strict extrapolation, where all observations lie on just one side of the the two closest rules in accordance with the partial order, the linear relation between the antecedent variables and the corresponding consequent variable can also be represented by a straight line. However, all the extrapolated rules lie on the extension (i.e. line P_1P_2 in Fig. 5) of the line segment which connects the two closest rules in the problem space (i.e. line P_0P_1 in Fig. 5). Because no interpolation is possible between the two closest rules, the extrapolated rule whose antecedent is located farthest from both antecedents of these two rules is deemed to be the most dissimilar to them and hence, should be modified the most.

Continue the example, and suppose that all interpolated rules lie on just one side of the two rules for interpolation and that A_{cj} ($2 \leq j \leq n - 1$) sits in the farthest place to these two rules on the extension of line P_0P_1 ($\forall x \in$

$\{2, 3, \dots, n-1\}$, $A_{cj} \succeq A_{cx}$ by the partial order). Therefore, interpolated rule $A_{1j}, A_{2j} \Rightarrow A_{3j}$ will be modified first. The modification replaces the interpolation line P_1P_2 with P_1P_3 . All other interpolated rules based on the same fuzzy reasoning component will be modified by the same *correction rate*. Particularly in this example, all the observations are greater than the corresponding antecedent values of these rules with respect to the partial order, the *correction rate* is the same as c^+ in Eq. 20. If all the observations are less than the corresponding antecedent values of these rules, the *correction rate* is equal to c^- in Eq. 20. For situations where certain observations are greater than the corresponding antecedent values of these rules while the others are less than such values, then the *correction rate* pair is the combination of the above, that is, (c^-, c^+) .

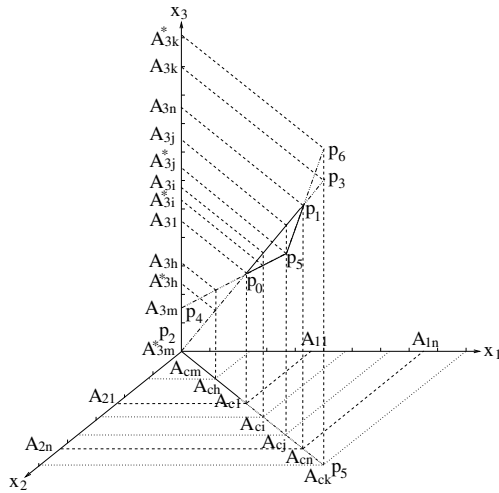

Fig. 6. Defective fuzzy reasoning component modification

Finally, when some of the observations are located between the corresponding antecedent values of the two rules for interpolation and all others are located outside with respect to the partial order, the interpolated rule whose antecedent sits in the middle most of the neighborhood of the two rules will be modified first. Suppose that A_{cj} ($2 \leq j \leq n-1$) sits in the middle most on the line P_0P_1 , then the original interpolation line P_2P_3 is replaced by two line segments P_4P_5 and P_5P_6 as illustrated in Fig. 6. In this case, the *correction rate* pair is still the same as the strict interpolation situation, that is Eq. 20.

Having chosen the first rule to modify and calculated the *correction rate* pair, the rest of the modification is exactly the same as that with single-antecedent situation, which is outlined in Sec. II-C and thus omitted here.

IV. AN ILLUSTRATE EXAMPLE

To illustrate the potential of this extended adaptive fuzzy interpolation and extrapolation method for multiple-antecedent rules, the example given in [11] is extended. The rule base is given as follows:

R_1 : If x_1 is A_{11} and x_2 is A_{21} , then x_3 is A_{31} ;

R_2 : If x_1 is A_{12} and x_2 is A_{22} , then x_3 is A_{32} ;

R_3 : If x_3 is A_{35} , then x_5 is A_{51} ;

R_4 : If x_3 is A_{36} , then x_5 is A_{52} ;

R_5 : If x_3 is A_{33} , then x_4 is A_{41} ;

R_6 : If x_3 is A_{34} , then x_4 is A_{42} ;

R_7 : If x_5 is A_{53} and x_6 is A_{61} , then x_7 is A_{73} ;

R_8 : If x_5 is A_{54} and x_6 is A_{62} , then x_7 is A_{74} ;

R_9 : If x_4 is A_{43} , then x_7 is A_{71} ;

R_{10} : If x_4 is A_{44} , then x_7 is A_{72} .

Given $\beta_0 = 0.5$ and six observations: $x_1 = A_{13} = (2.0, 3.0, 4.0)$, $x_1 = A_{14} = (2.6, 3.6, 4.6)$, $x_2 = A_{23} = (18.0, 19.0, 20.0)$, $x_4 = A_{45} = (9.5, 10.5, 11.5)$, $x_5 = A_{55} = (8.0, 9.0, 10.0)$, and $x_6 = A_{63} = (12.0, 13.0, 14.0)$, the original observations as well as interpolated results by scale and move transformation-based interpolation technique are presented in Fig. 7 and the interpolation procedures are illustrated in Fig. 8. Here, rules R_1, R_2, R_7 and R_8 are of two antecedents each. For observations (A_{13}, A_{23}) and (A_{14}, A_{23}) , R_1 and R_2 are the two closest rules while for (A_{55}, A_{63}) and (A_{56}, A_{63}) , R_7 and R_8 are the two closest. Once obtaining the two closest rules, the *relative placement factor*, *scale rate* and *move rate* of the consequent of each observation can be calculated by following Eqs. 15, 17 and 18, respectively. From this, the rest of the interpolation procedure is the same as that of the single-antecedent one.

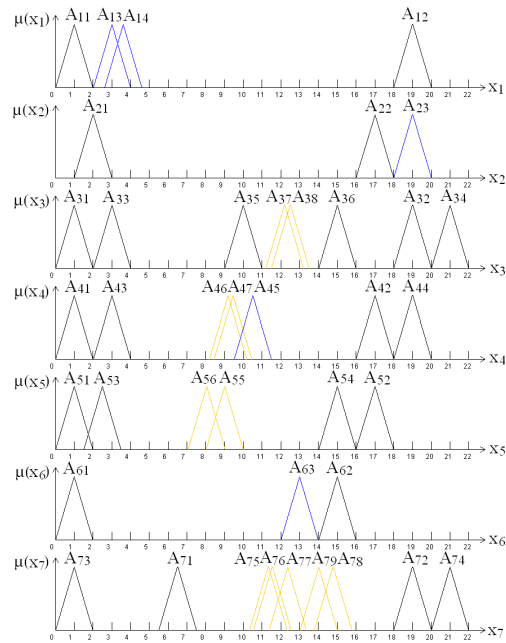

Fig. 7. Fuzzy sets used in the example

A. Dependency recording by ATMS

In Fig. 8, an arrowed line flanked by two rules R_i and R_j represents a fuzzy reasoning component, which is denoted as R_iR_j , where R_i and R_j are the neighboring rules used for interpolation. ATMS nodes and contradictions are represented by circles. Particularly, each of F_i , $i \in \{1, 2, \dots, 5\}$,

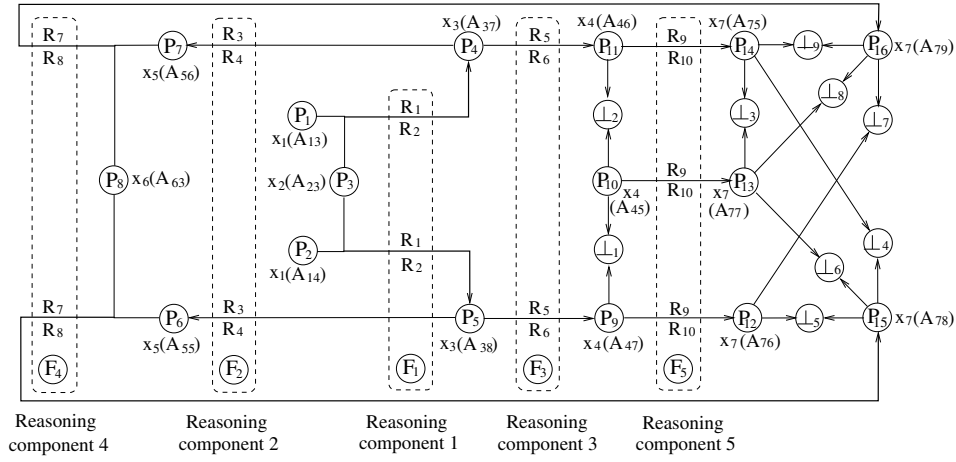

Fig. 8. Discrepancy records in ATMS

is a node denoting a fuzzy reasoning component; each of P_j , $j \in \{1, 2, \dots, 16\}$, is a node denoting a proposition; and each of \perp_k , $k \in \{1, 2, \dots, 9\}$, denotes a β_0 -contradiction. These ATMS nodes and contradictions are listed as follows, with all justifications omitted:

- $F_1 : \langle R_1 R_2, \{\{R_1 R_2\}\} \rangle$; $F_2 : \langle R_3 R_4, \{\{R_3 R_4\}\} \rangle$;
 $F_3 : \langle R_5 R_6, \{\{R_5 R_6\}\} \rangle$; $F_4 : \langle R_7 R_8, \{\{R_7 R_8\}\} \rangle$;
 $F_5 : \langle R_9 R_{10}, \{\{R_9 R_{10}\}\} \rangle$; $P_1 : \langle x_1 = A_{13}, \{\{\}\} \rangle$;
 $P_2 : \langle x_1 = A_{14}, \{\{\}\} \rangle$; $P_3 : \langle x_2 = A_{23}, \{\{\}\} \rangle$;
 $P_4 : \langle x_3 = A_{37}, \{\{R_1 R_2\}\} \rangle$; $P_5 : \langle x_3 = A_{38}, \{\{R_1 R_2\}\} \rangle$;
 $P_6 : \langle x_5 = A_{55}, \{\{\}\} \rangle$;
 $P_7 : \langle x_5 = A_{56}, \{\{R_1 R_2, R_3 R_4\}\} \rangle$;
 $P_8 : \langle x_6 = A_{63}, \{\{\}\} \rangle$;
 $P_9 : \langle x_4 = A_{47}, \{\{R_1 R_2, R_5 R_6\}\} \rangle$;
 $P_{10} : \langle x_4 = A_{45}, \{\{\}\} \rangle$;
 $P_{11} : \langle x_4 = A_{46}, \{\{R_1 R_2, R_5 R_6\}\} \rangle$;
 $P_{12} : \langle x_7 = A_{76}, \{\{R_1 R_2, R_5 R_6, R_9 R_{10}\}\} \rangle$;
 $P_{13} : \langle x_7 = A_{77}, \{\{R_9 R_{10}\}\} \rangle$;
 $P_{14} : \langle x_7 = A_{75}, \{\{R_1 R_2, R_5 R_6, R_9 R_{10}\}\} \rangle$;
 $P_{15} : \langle x_7 = A_{78}, \{\{R_7 R_8\}\} \rangle$;
 $P_{16} : \langle x_7 = A_{79}, \{\{R_1 R_2, R_3 R_4, R_7 R_8\}\} \rangle$;
 $\perp_1 : \langle \perp, \{\{R_1 R_2, R_5 R_6\}\} \rangle$;
 $\perp_2 : \langle \perp, \{\{R_1 R_2, R_5 R_6\}\} \rangle$;
 $\perp_3 : \langle \perp, \{\{R_1 R_2, R_5 R_6, R_9 R_{10}\}\} \rangle$;
 $\perp_4 : \langle \perp, \{\{R_1 R_2, R_5 R_6, R_7 R_8, R_9 R_{10}\}\} \rangle$;
 $\perp_5 : \langle \perp, \{\{R_1 R_2, R_5 R_6, R_7 R_8, R_9 R_{10}\}\} \rangle$;
 $\perp_6 : \langle \perp, \{\{R_7 R_8, R_9 R_{10}\}\} \rangle$;
 $\perp_7 : \langle \perp, \{\{R_1 R_2, R_3 R_4, R_5 R_6, R_7 R_8, R_9 R_{10}\}\} \rangle$;
 $\perp_8 : \langle \perp, \{\{R_1 R_2, R_3 R_4, R_7 R_8, R_9 R_{10}\}\} \rangle$;
 $\perp_9 : \langle \perp, \{\{R_1 R_2, R_3 R_4, R_5 R_6, R_7 R_8, R_9 R_{10}\}\} \rangle$.

The label of node P_6 is $\{\{\}\}$. This is because: a) the observation (always supported by an empty set environment), represented by node P_6 , is identical as the derived result from node P_5 by fuzzy reasoning component F_2 (with environment $\{R_1 R_2, R_3 R_4\}$), and b) the environment $\{R_1 R_2, R_3 R_4\}$ is a superset of the environment $\{\}$ and is thus removed. Similarly, the labels of node P_{15} and contradictions \perp_4 , \perp_5 and \perp_6 are also minimized above. A

specific ATMS node “false”, denoted by P_\perp , represents all the contradictions listed above from \perp_1 to \perp_9 , collectively. There are just two minimal environments in the label of the “false” node:

$$P_\perp : \langle \perp, \{\{R_1 R_2, R_5 R_6\}, \{R_7 R_8, R_9 R_{10}\}\} \rangle.$$

The label of P_\perp means that at least one element of the set $\{R_1 R_2, R_5 R_6\}$ and one element of the set $\{R_7 R_8, R_9 R_{10}\}$ are faulty simultaneously.

B. Candidate generation by GDE

Four minimal candidates are generated, each of which is composed by taking one element from each environment in the label of the “false” node:

$$\begin{aligned}
 C_1 &: [R_1 R_2, R_7 R_8]; & C_2 &: [R_1 R_2, R_9 R_{10}]; \\
 C_3 &: [R_5 R_6, R_7 R_8]; & C_4 &: [R_5 R_6, R_9 R_{10}].
 \end{aligned}$$

C. Candidate modification

Any one of these four minimal candidates can be taken for modification first because they are of the same size in cardinality. Particularly in this example, C_3 is taken randomly to modify first. Four rules have been interpolated through the two fuzzy reasoning components that comprise the candidate:

- IR_1 : If x_3 is A_{37} , then x_4 is A_{46} ;
 IR_2 : If x_3 is A_{38} , then x_4 is A_{47} ;
 IR_3 : If x_5 is A_{55} and x_6 is A_{63} , then x_7 is A_{78} ;
 IR_4 : If x_5 is A_{56} and x_6 is A_{63} , then x_7 is A_{79} .

For fuzzy reasoning component $R_5 R_6$, the culprit interpolated rule IR_1 will be modified first because fuzzy set A_{37} is located nearer the middle than A_{38} . Suppose that the *relative placement factor* of the modified consequence is λ_{46}^* . Then the correction rate pair is:

$$\begin{cases}
 c_{R_5 R_6}^- = \frac{\lambda_{46}^*}{\lambda_{46}} \\
 c_{R_5 R_6}^+ = \frac{1 - \lambda_{46}^*}{1 - \lambda_{46}}.
 \end{cases}$$

Accordingly, IR_2 will be modified with respect to the generated *correction rate pair* $(c_{R_5 R_6}^-, c_{R_5 R_6}^+)$. The *relative placement factor* λ_{47}^* of the modified consequence satisfies:

$$1 - \lambda_{47}^* = (1 - \lambda_{47}) \cdot c_{R_5 R_6}^+.$$

The interpolated rule consequences after modification, A_{46}^* and A_{47}^* can thus be expressed by:

$$\begin{cases} A_{46}^{*'} = (1 - \lambda_{46}^*)A_{41} + \lambda_{46}^*A_{42} \\ A_{47}^{*'} = (1 - \lambda_{47}^*)A_{41} + \lambda_{47}^*A_{42} \\ T(A_{37}', A_{37}) = T(A_{46}^{*'}, A_{46}^*) \\ T(A_{38}', A_{38}) = T(A_{47}^{*'}, A_{47}^*). \end{cases}$$

Fuzzy sets A_{46}^* and A_{47}^* must satisfy the following constraints if they are $(1 - \beta_0)$ -consistent:

$$(A_{46}^*)_{\beta_0} \cap (A_{47}^*)_{\beta_0} \cap (A_{45})_{\beta_0} \neq \emptyset.$$

Similarly, the culprit interpolated rules IR_3 and IR_4 are also modified by following the modification procedure outlined in Sec. III-D. The following constraints are hence generated:

$$\begin{cases} c_{R_7R_8}^- = \frac{\lambda_{79}^*}{\lambda_{79}^*} \\ c_{R_7R_8}^+ = \frac{1 - \lambda_{79}^*}{1 - \lambda_{79}^*} \\ (1 - \lambda_{78}^*) = (1 - \lambda_{78}) \cdot c_{R_7R_8}^+ \\ A_{78}^{*'} = (1 - \lambda_{78}^*)A_{73} + \lambda_{78}^*A_{74} \\ A_{79}^{*'} = (1 - \lambda_{79}^*)A_{73} + \lambda_{79}^*A_{74} \\ T((A_{55}', A_{63}'), (A_{55}, A_{63})) = T(A_{78}^{*'}, A_{78}^*) \\ T((A_{56}', A_{63}'), (A_{56}, A_{63})) = T(A_{79}^{*'}, A_{79}^*) \\ (A_{78}^*)_{\beta_0} \cap (A_{79}^*)_{\beta_0} \cap (A_{77})_{\beta_0} \neq \emptyset. \end{cases}$$

The propagations of all these modified rules need to be $(1 - \beta_0)$ -consistent as well, which can be ensured by introducing the following simultaneous equations:

$$\begin{cases} A_{75}^* = I(A_{46}^*, R_9R_{10}) \\ A_{76}^* = I(A_{47}^*, R_9R_{10}) \\ (A_{75}^*)_{\beta_0} \cap (A_{76}^*)_{\beta_0} \cap (A_{78}^*)_{\beta_0} \cap (A_{79}^*)_{\beta_0} \cap (A_{77})_{\beta_0} \neq \emptyset. \end{cases}$$

One of the solutions led by solving these simultaneous equations is illustrated in Fig. 9. It is clear from this result that there is no β_0 -contradiction any more and thus consistency has been restored. This means that the original inconsistent interpolation process has been corrected with consistent interpolated results throughout.

V. CONCLUSIONS

This paper has generalized the recent work on adaptive fuzzy interpolation [11]. This is achieved by introducing fuzzy extrapolation to the adaptive approach and extending the approach to involving multiple-antecedent rules. The work first uses the classical ATMS-based GDE approach to detect and locate faults during the process of fuzzy interpolation/extrapolation. It then modifies the identified culprit interpolated or extrapolated rule consequents by replacing the original linear interpolation/extrapolation with first-order piecewise linear approximation, in an effort to restore consistency. The working of this method is illustrated with a practically significant example.

Whilst the proposed work is promising, it relies upon the assumption that all rules for interpolation/extrapolation which are provided in the initial rule base are totally true

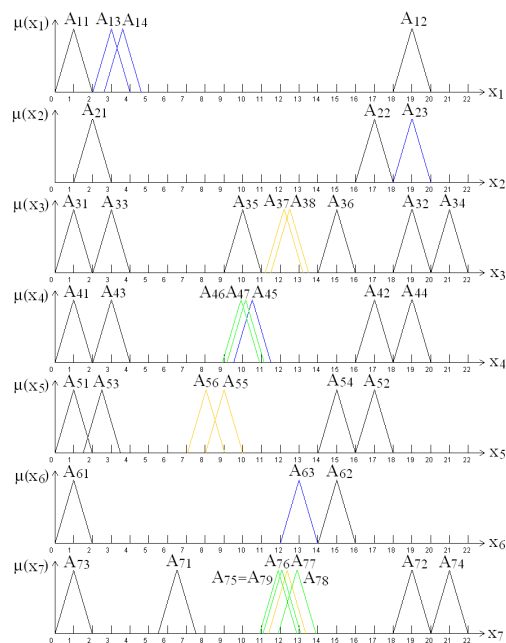

Fig. 9. The solution for the running example

and fixed. This may not be the case in some real-world problems, despite the fact that it is a common assumption made in the literature of interpolative reasoning. Thus, further development on the work may be desirable in allowing such rules to become themselves diagnosable and modifiable. It is also very interesting to develop a unified inconsistency diagnosis and fault correction mechanism on a fuzzy reasoning platform that implements both standard fuzzy inference and fuzzy interpolation/extrapolation.

REFERENCES

- [1] P. Baranyi, L. T. Kóczy, and T. D. Gedeon, "A generalized concept for fuzzy rule interpolation," *IEEE T. Fuzzy Syst.*, vol. 12, no. 6, pp. 820–837, 2004.
- [2] Y. Chang, S. Chen, and C. Liao, "Fuzzy interpolative reasoning for sparse fuzzy-rule-based systems based on the areas of fuzzy sets," *IEEE T. Fuzzy Syst.*, vol. 16, no. 5, pp. 1285–1301, 2008.
- [3] S. Chen and Y. Ko, "Fuzzy interpolative reasoning for sparse fuzzy rule-based systems based on α -cuts and transformations techniques," *IEEE T. Fuzzy Syst.*, vol. 16, no. 6, pp. 1626–1648, 2008.
- [4] S. Chen, Y. Ko, Y. Chang, and J. Pan, "Weighted fuzzy interpolative reasoning based on weighted increment transformation and weighted ratio transformation techniques," *IEEE T. Fuzzy Syst.*, vol. 17, no. 6, pp. 1412–1427, 2009.
- [5] J. de Kleer, "An assumption-based TMS," *Artif. Intell.*, vol. 28, no. 2, pp. 127–162, 1986.
- [6] J. de Kleer and B. C. Williams, "Diagnosing multiple faults," *Artif. Intell.*, vol. 32, no. 1, pp. 97–130, 1987.
- [7] Z. Huang and Q. Shen, "Fuzzy interpolative reasoning via scale and move transformations," *IEEE Trans. Fuzzy Syst.*, vol. 14, no. 2, pp. 340–359, 2006.
- [8] —, "Fuzzy interpolation and extrapolation: a practical approach," *IEEE Trans. Fuzzy Syst.*, vol. 16, no. 1, pp. 13–28, 2008.
- [9] L. T. Kóczy and K. Hirota, "Approximate reasoning by linear rule interpolation and general approximation," *Int. J. Approx. Reason.*, vol. 9, no. 3, pp. 197–225, 1993.
- [10] —, "Size reduction by interpolation in fuzzy rule bases," *IEEE Trans. Syst., Man Cybern.*, vol. 27, no. 1, pp. 14–25, 1997.
- [11] L. Yang and Q. Shen, "Towards adaptive interpolative reasoning," in *Proc. IEEE Int. Conf. Fuzzy Syst.*, 2009, pp. 542–549.