



**Manchester
Metropolitan
University**

[Pessali-Marques, Barbara](#) (2020) Influence of muscle-tendon unit structure, function, and menstrual cycle phase on dancers' physical performance. Doctoral thesis (PhD), Manchester Metropolitan University in collaboration with Lancashire Cotton Mills Ltd.

Downloaded from: <http://e-space.mmu.ac.uk/626087/>

Usage rights: Creative Commons: Attribution-Noncommercial-No Derivative Works 4.0

Please cite the published version

<https://e-space.mmu.ac.uk>

Influence of muscle-tendon unit structure,
function, and menstrual cycle phase in
dancers' physical performance

B PESSALI-MARQUES
PhD 2020

Influence of muscle-tendon unit structure,
function, and menstrual cycle phase in
dancers' physical performance

BÁRBARA PESSALI MARQUES

A thesis submitted in partial fulfilment of the
requirements of Manchester Metropolitan
University for the degree of Doctor of
Philosophy

Department of Exercise and Sport Science
Manchester Metropolitan University in
collaboration with Lancashire Cotton Mills
Ltd

2020

Table of Contents

Influence of muscle-tendon unit structure, function, and menstrual cycle phase in dancers' physical performance.....	i
Table of Contents	iii
List of abbreviations	ix
List of Tables.....	xii
List of Figures.....	xv
List of Equations	xix
Acknowledgements	xx
Abstract	xxi
Introduction.....	1
1. Narrative Literature Review	8
1.1 Stiffness	9
1.1.1 Factors that may affect S_{MTU}	14
1.1.1.1 The menstrual cycle.....	14
1.1.1.2 Oral Contraceptives	22
1.1.1.3 Sex Differences	23
1.1.1.4 Stretching	23
1.1.1.5 Strength and Cross-Sectional Area	28
1.1.1.6 Changes in the intramuscular structure and/or composition.....	30
1.1.1.7 Warm-up and temperature	31
1.2 The interaction between S_{MTU} , ROM and jump height capabilities	32
1.3 Flexibility training	37
1.3.1 Biomechanical variables involved in MTU response to flexibility training: definitions	37
1.3.2 Sensory variables involved in MTU response to flexibility training: definitions	39

1.4 Strength training.....	45
1.4.1 Variables involved in the jump performance: definition	46
2. Thesis Aims.....	51
2.1 Aim	51
2.2 Objectives	51
Overall Methods	52
3.1 Ethics	53
3.2 Participants.....	53
3.3 Equipment	58
3.3.1 Menstrual calendar, basal thermometer, and ovulation kit.....	58
3.3.2 Venepuncture & blood/sera analyses	59
3.3.3 Endocrine Analyses.....	60
3.3.4 Ultrasound Imaging	63
3.3.5 Passive Flexibility Test & Flexibility intervention	66
3.3.6 3-D motion analysis	69
3.3.7 Force platform and vertical jump tests.....	72
3.3.8 Electromyography	73
3.3.9 Ice Water Test	76
3.3.10 Visual Analogue Scale (VAS).....	76
3.3.11 Questionnaires	77
3.3.11.1 The Self-Estimated Functional Inability because of Pain (SEFIP)	77
3.3.11.2 Pain Anxiety Symptom Scale (PASS) Short Form 20	77
3.3.11.3 The Physical Activity Readiness Questionnaire (PAR-Q).....	78
3.3.12 Anthropometric measurement and body composition	78
3.3.13 Familiarisation	78
Chapter 1:.....	80

Reliability of hip flexion Flexibility Test Equipment	80
4.1 Introduction.....	81
4.2 Methods	85
4.2.1 Participants.....	85
4.2.2 Procedures.....	85
4.3 Statistical analyses	86
4.4 Results	86
4.4.1 Flexibility Test Equipment development	86
4.4.1.1 Flexibility Test Equipment - Data acquisition and analysis	91
4.4.1.2 Flexibility Test Equipment - Tests	92
4.4.1.3 Flexibility Test Equipment - Intervention.....	93
4.4.2 Reliability	94
4.5 Discussion	95
4.6 Conclusion	97
Chapter 2: Functional and structural characteristics of the MTU and lower limb asymmetries between dancers and non-dancers.....	98
5.1 Introduction.....	99
5.2 Methods	101
5.2.1 Participants.....	101
5.2.2 Procedures.....	102
5.2.3 Outcome variables.....	104
5.3 Statistical analyses	104
5.4 Results	105
5.4.1 Parametricity checks.....	105
5.4.2 MTU functional characteristics and flexibility performance: lower limb dominance and group comparisons	106
5.4.3 MTU functional characteristics and jump performance: group comparisons	109

5.4.4 MTU functional characteristics and jump performance: Lower limb dominance and group comparisons.....	110
5.4.5 MTU structural characteristics: Lower limb dominance and group comparisons .	113
5.5 Discussion	117
5.6 Conclusion	125
Chapter 3: Impact of an acute stretch intervention on lower limb asymmetries, functional characteristics of the MTU and vertical jump and flexibility performance in dancers under contraception	126
6.1 Introduction.....	127
6.2 Methods	128
6.2.1 Participants.....	128
6.2.2 Procedures.....	129
6.2.3 Outcome variables.....	130
6.3 Statistical Analyses.....	131
6.4 Results	131
6.4.1 Parametricity checks.....	131
6.4.2 MTU functional characteristics and flexibility performance after stretching: condition and time comparisons	132
6.4.3 MTU functional characteristics and vertical jump performance after stretching: condition and time comparisons	135
6.4.4 MTU functional characteristics and jump performance: Pre- and Post-test comparisons	137
6.5 Discussion	139
6.6 Conclusion	146
Chapter 4: Flexibility asymmetry and impact of an acute stretch intervention on the jump kinematics in dancers under contraception	147
7.1 Introduction.....	148
7.2 Methods	150

7.2.1 Participants.....	150
7.2.2 Procedures.....	150
7.2.3 Outcome variables.....	150
7.3 Statistical Analyses.....	152
7.4 Results	152
7.4.1 Parametricity checks.....	152
7.4.2 Vertical jumps joint angles: Condition (Training and Control) and Timepoint (Pre- and Post-test) comparisons.....	153
7.4.3 Vertical jumps angular velocity at eccentric phase: Condition (Training and Control) and Time (Pre- and Post-test) comparisons	161
CMJ: Countermovement jump, SJ: Countermovement jump. Variables in light: not statistically significant. Variables in bold: statistically significantly different. * Statistically significant difference between time points (Pre- and Post-test). # Statistically significant difference between conditions (Training and Control).	164
7.4.4 EMG _{RF} : Condition (Training and Control) and Time (Pre- and Post-test) comparisons	164
7.4.5 Vertical jumps joint angles: Δ Time [(Post-Pre)/Pre] and Condition (Training and Control) comparisons	165
7.4.6 Vertical jumps angular velocity: Δ Time [(Post-Pre)/Pre] and Condition (Training and Control) comparisons	166
7.4.7 Vertical jumps EMG: Δ Time [(Post-Pre)/Pre] and Condition (Training and Control) comparisons	167
7.4.6 Hormonal concentration (Oestrogen and Progesterone) correlations with all dependent variables: Condition (Training and Control) and Time (Pre- and Post-test) comparisons	167
7.5 Discussion	168
7.6 Conclusion	174
Chapter 5: Any effect of Menstrual Cycle Phase (peak vs trough oestrogen) on the modulation of flexibility by muscle structure and function in dancers	176

8.1 Introduction.....	177
8.2 Methods	178
8.2.1 Participants.....	178
8.2.2 Procedures.....	178
8.2.3 Outcome variables.....	181
8.3 Statistical Analyses.....	182
8.4 Results	182
8.4.1 Parametricity checks.....	182
8.4.2 Hormonal variation across menstrual cycle phases	184
8.4.3 Structural and functional characteristics across the menstrual cycle: phases and limb comparisons	185
8.4.4 Structural and functional characteristics across the menstrual cycle: delta [(D – nD)/D] comparisons between the phases	189
8.4.5 Correlations between change in outcome variables and change in hormone levels	190
8.5 Discussion	191
8.5.1 Raw data analyses	191
8.5.2 Relative change analyses	198
8.6 Conclusion	199
Overarching Discussion	200
Practical applications.....	219
Studies limitations	220
Recommendations for future work	220
References.....	222
.....	266

List of abbreviations

A _a	Ankle angle
ACL	Anterior cruciate ligaments
ACSM	American College of Sports Medicine
AS	Active stiffness
A _v	Ankle angular velocity
BIA	Bioelectrical impedance analysis
C	Control
CA	Constant angle
CIR	Circumference
CMJ	Countermovement jump
CON	Concentric
CSA	Cross-sectional area
CT	Constant torque
ECC	Eccentric
E.G.	Example
EMG	Electromyography
D	Dominant
DCN	Dancer – Contemporary – Not-taking contraception
DCT	Dancer – Contemporary – Taking contraception
DEG	Degree
DIF	Difference
F	Force
FTE	Flexibility Test Equipment
FSH	Follicle-stimulating hormone
FSS	First Sensation of Stretch
FSS _{ROM}	First Sensation of Stretch range of motion
FSS _{torque}	First Sensation of Stretch torque
FST	First sensation of tightness
GRF	Ground reaction force
H _a	Hips angle
hsCRP	C-reactive protein

H_v	Hips angular velocity
ICC	Intraclass correlation coefficient
IPAQ	International Physical Activity Questionnaire
IWT	Ice water test
K_a	Knee angle
K_v	Knee angular velocity
LH	Luteinising hormone
MaxGET	Maximum Gravity Effect Torque
MCP	Menstrual cycle phase
MTU	Muscle-tendon unit
nD	Non-dominant
NN	Non-dancer – Not taking contraception
OC	Oral contraception
PASS	Pain Anxiety Symptom Scale
ParQ	Physical Activity Readiness Questionnaire
PEC	Parallel elastic components
PhD	Philosophy Doctor
RF	Rectus femoris
RMS	Root Mean Square
ROM	Range of Motion
ROM_{Max}	Maximal range of motion
RT	Resistance torque
SEC	Series elastic components
SEFIP	Self-estimated functional Inability because of pain
SEM	Standard error of measurement
SEM%	Percentage of the Standard error of measurement
Sig	Significance
SJ	Squat jump
S_{MTU}	Muscle-tendon unit stiffness
S_{Mus}	Muscle stiffness
SSC	Stretch shortening cycle
ST	Semitendinosus

S_{Ten}	Tendon stiffness
T	Training
TENS	Transcutaneous electrical nerve stimulation
Torque _{Max}	Maximal torque
UK	United Kingdom
ULS	Universal Laser System
USA	United States of America
VAS	Visual analogue scale

List of Tables

TABLE 1: MAIN HORMONES REGULATORS OF THE FEMALE REPRODUCTIVE SYSTEM AND THEIR ACTION.	17
TABLE 2: STRETCH TECHNIQUES	24
TABLE 3: LITERATURE REVIEW ON STUDIES EVALUATING S_{MTU}	35
TABLE 4: PHYSICAL POSSIBILITIES FOR THE UNDERSTANDING OF THE MTU RESPONSE TO STRETCHING.....	44
TABLE 5: THE ASSESSMENT OF VERTICAL JUMP COMPONENTS	48
TABLE 6: CHARACTERISATION OF THE PARTICIPANTS IN THE OVERALL THESIS' RESEARCH (AVERAGE \pm STANDARD DEVIATION)	54
TABLE 7: DATA CHAPTER TESTS, PROTOCOLS AND VARIABLES OF THE CURRENT THESIS.....	55
TABLE 8: SUMMARY OF ALL OUTCOME VARIABLES.	56
TABLE 9: ASSAY PROCEDURES FOR THE ENDOCRINE ANALYSES PERFORMED IN THE CURRENT THESIS.	62
TABLE 10: RELIABILITY VARIABLES ASSESSED BY THE FLEXIBILITY TEST EQUIPMENT	94
TABLE 11: WEEKLY STRUCTURED PHYSICAL ACTIVITY (AVERAGE \pm STANDARD DEVIATION - HOURS).....	101
TABLE 12: OTHER PHYSICAL ACTIVITIES PRACTISED (ABSOLUTE [N] AND PERCENTAGE [%]).....	101
TABLE 13: REPORTED INJURIES	102
TABLE 14: OUTCOME VARIABLES CHAPTER 2.....	104
TABLE 15: NON-PARAMETRIC DATA – SHAPIRO WILK.	105
TABLE 16: CHARACTERISATION OF THE PARTICIPANTS (AVERAGE \pm STANDARD DEVIATION)	105
TABLE 17: GROUP COMPARISON FOR THE VERTICAL JUMP PERFORMANCE.	109
TABLE 18: CMJ EMG_{RF} PEAK, REST AND RATIO (AVERAGE \pm STANDARD DEVIATION)	111
TABLE 19: CMJ EMG_{ST} PEAK, REST AND RATIO (AVERAGE \pm STANDARD DEVIATION).....	112
TABLE 20: SJ EMG_{RF} PEAK, REST AND RATIO (AVERAGE \pm STANDARD DEVIATION)	112
TABLE 21: SJ EMG_{ST} PEAK, REST AND RATIO (AVERAGE \pm STANDARD DEVIATION)	113
TABLE 22: UNPAIRED T-TESTS COMPARING DANCERS AND NON-DANCERS FOR THE PAIN ANXIETY SYMPTOM SCALE (PASS) ...	114
TABLE 23: MANN-WHITNEY COMPARING DANCERS AND NON-DANCERS FOR THE SELF-ESTIMATED FUNCTIONAL INABILITY BECAUSE OF PAIN (SEFIP).....	115
TABLE 24: MANN-WHITNEY COMPARING DANCERS AND NON-DANCERS FOR THE SELF-ESTIMATED FUNCTIONAL INABILITY BECAUSE OF PAIN TOTAL SCORES (SEFIP) AND ICE WATER TEST (IWT) TOTAL TIME.	115
TABLE 25: DESCRIPTIVE STATISTICS OF THE VISUAL ANALOGUE SCALE (VAS) OF PAIN RATED DURING THE ICE WATER TEST	115
TABLE 26: HORMONE CONCENTRATION (AVERAGE \pm STANDARD DEVIATION)	116
TABLE 27: HORMONE CONCENTRATION AND DEPENDENT VARIABLES CORRELATIONS.....	117
TABLE 28: UNIVARIATE ANCOVA	117
TABLE 29: OUTCOME VARIABLES CHAPTER 3.....	130
TABLE 30: NON-PARAMETRIC DATA – SHAPIRO WILK	132
TABLE 31: CHARACTERISATION OF THE PARTICIPANTS (AVERAGE \pm STANDARD DEVIATION)	132
TABLE 32: CONTRACEPTION STATUS	132
TABLE 33: PAIRED T-TESTS (WHEN PARAMETRIC) AND MANN-WHITNEY U (WHEN NON-PARAMETRIC) COMPARING PRE- AND POST-TEST IN THE CMJ.....	137
TABLE 34: PAIRED T-TESTS (WHEN PARAMETRIC) AND MANN-WHITNEY (WHEN NON-PARAMETRIC) COMPARING PRE- AND POST- TEST IN THE SJ.....	137

TABLE 35: PAIRED T-TESTS (WHEN PARAMETRIC) AND MANN-WHITNEY (WHEN NON-PARAMETRIC) OF THE Δ BETWEEN THE C AND T CONDITIONS	138
TABLE 36: CONCENTRATION OF OESTROGEN AND PROGESTERONE IN BOTH GROUPS (AVERAGE \pm STANDARD DEVIATION)	139
TABLE 37: HORMONE CONCENTRATION AND DEPENDENT VARIABLES CORRELATIONS	139
TABLE 38: OUTCOME VARIABLES CHAPTER 4	150
TABLE 39: NON-PARAMETRIC VARIABLES (SHAPIRO-WILK)	152
TABLE 40: NON-PARAMETRIC VARIABLES' DELTA OF PRE- AND POST-TESTS PER GROUP (SHAPIRO-WILK)	153
TABLE 41: DESCRIPTIVE STATISTICS OF CMJ ANGLES IN DEGREES (AVERAGE \pm STANDARD DEVIATION)	153
TABLE 42: DESCRIPTIVE STATISTICS OF SJ ANGLES IN DEGREES (AVERAGE \pm STANDARD DEVIATION)	154
TABLE 43: VERTICAL JUMPS ANOVA REPEATED MEASURES WITH PAIRWISE COMPARISONS (WHEN PARAMETRIC) AND FRIEDMAN WITH WILCOXON COMPARISONS (WHEN NON-PARAMETRIC) OF JOINT ANGLES.	156
TABLE 44: DESCRIPTIVE STATISTICS OF CMJ ANGULAR VELOCITIES IN DEGREES PER SECOND (AVERAGE \pm STANDARD DEVIATION)	161
TABLE 45: DESCRIPTIVE STATISTICS OF SJ ANGULAR VELOCITIES IN DEGREES PER SECOND (AVERAGE \pm STANDARD DEVIATION) ..	162
TABLE 46: VERTICAL JUMPS ANOVA REPEATED MEASURES WITH PAIRWISE COMPARISONS (WHEN PARAMETRIC) AND FRIEDMAN WITH WILCOXON COMPARISONS (WHEN NON-PARAMETRIC) OF ANKLE, HIP AND KNEE ANGULAR VELOCITIES IN DEGREES PER SECOND	163
TABLE 47: AVERAGE AND STANDARD DEVIATION OF CMJ AND SJ ANKLE, HIP AND KNEE ANGULAR VELOCITY AT THE ECCENTRIC AND CONCENTRIC PHASES IN DEGREES PER SECOND	163
TABLE 48: DESCRIPTIVE STATISTICS OF RECTUS FEMORIS EMG ACTIVITY (MV) (AVERAGE \pm STANDARD DEVIATION)	164
TABLE 49: DESCRIPTIVE STATISTICS OF SEMITENDINOSUS EMG ACTIVITY (MV) (AVERAGE \pm STANDARD DEVIATION)	164
TABLE 50: VERTICAL JUMPS ANOVA REPEATED MEASURES WITH PAIRWISE COMPARISONS (WHEN PARAMETRIC) AND FRIEDMAN WITH WILCOXON COMPARISONS (WHEN NON-PARAMETRIC) OF RELATIVE (I.E. RATIO) EMG DURING VERTICAL JUMPS ..	165
TABLE 51: PAIRED T-TESTS (WHEN PARAMETRIC) OR WILCOXON (WHEN NON-PARAMETRIC) OF THE Δ JOINT ANGLES BETWEEN THE C AND T CONDITIONS (%)	165
TABLE 52: PAIRED T-TESTS (WHEN PARAMETRIC) OR WILCOXON (WHEN NON-PARAMETRIC) OF THE Δ ANGULAR VELOCITY BETWEEN C AND T CONDITIONS (%)	166
TABLE 53: PAIRED T-TESTS (WHEN PARAMETRIC) AND WILCOXON (WHEN NON-PARAMETRIC) OF THE Δ EMG BETWEEN THE C AND T CONDITIONS	167
TABLE 54: SIGNIFICANT CORRELATION RESULTS	167
TABLE 55: OUTCOME VARIABLES	181
TABLE 56: DESCRIPTIVE ANALYSIS OF THE DCN ACROSS THE MENSTRUAL CYCLE PHASES (AVERAGE \pm STANDARD DEVIATION) ..	182
TABLE 57: NON-PARAMETRIC DATA. SHAPIRO-WILK RESULTS. DATA PRESENTED ARE <i>P</i> STATISTICS.	183
TABLE 58: NON-PARAMETRIC DATA $\Delta [(D-ND)/D]$ VARIABLES. SHAPIRO-WILK RESULTS. DATA PRESENTED ARE <i>P</i> STATISTICS ..	184
TABLE 59: NON-PARAMETRIC DATA RATION HORMONES CONCENTRATION AT LUTEAL AND OVULATORY BY FOLLICULAR PHASE. SHAPIRO-WILK RESULTS. DATA PRESENTED ARE <i>P</i> STATISTICS.	184
TABLE 60: ANOVA REPEATED MEASURES THREE FACTORS WHEN PARAMETRIC WITH PAIRWISE COMPARISONS WHEN NECESSARY AND FRIEDMAN WHEN NON-PARAMETRIC DATA WITH WILCOXON WHEN NECESSARY (PHASE COMPARISONS).	185

TABLE 61: ANOVA REPEATED MEASURES SIX FACTORS (DOMINANT AND NON-DOMINANT LIMB AT FOLLICULAR, OVULATORY AND LUTEAL PHASES) AND THREE FACTORS (EITHER LIMB COMPARISONS IN EACH PHASE OR PHASE COMPARISONS). DATA PRESENTED ARE <i>P</i> STATISTICS.....	186
TABLE 62: ANOVA REPEATED MEASURES THREE FACTORS WHEN PARAMETRIC WITH PAIRWISE COMPARISONS WHEN NECESSARY AND FRIEDMAN WHEN NON-PARAMETRIC DATA WITH WILCOXON WHEN NECESSARY (PHASE COMPARISONS). DATA PRESENTED ARE <i>P</i> STATISTICS.....	189
TABLE 63: PEARSON (WHEN PARAMETRIC) AND SPEARMAN (WHEN NON-PARAMETRIC) SIGNIFICANT CORRELATIONS. DATA PRESENTED ARE <i>P</i> STATISTICS.....	190
TABLE 64: WILCOXON ANALYSIS OF THE HORMONES IN LUTEAL/FOLLICULAR AND OVULATORY/FOLLICULAR.....	191
TABLE 65: SUMMARY OF THE DATA CHAPTERS RESULTS	207

List of Figures

FIGURE 1: S_{MTU} CAN BE CALCULATED THROUGH THE CHANGE IN IN THE RESISTANCE TORQUE (T) DIVIDED BY THE CHANGE IN ROM. ANY PORTION OF THE SLOPE MAY BE USED TO CALCULATE THE PASSIVE S_{MTU} , USING A TANGENT LINE TO THE CURVE (PEARSON AND ONAMBELE, 2005, PEARSON AND ONAMBÉLÉ, 2012, PEARSON AND ONAMBELE, 2006). MODIFIED FROM CABIDO ET AL. (2014).	4
FIGURE 2: DIFFERENCE IN S_{MTU} BETWEEN TWO DANCERS. DANCER 1 NEEDS GREATER PASSIVE TORQUE TO MOVE THE LIMB AND ACHIEVE THE SAME ROM AS DANCER 2, HOWEVER, IS ABLE TO ABSORB MORE ENERGY THAT COULD BE USED IN JUMPS. NOTE: THE CURVE IS A THEORETICAL ILLUSTRATION.....	4
FIGURE 3: TENDON HYSTERESIS DURING THE LOADING AND UNLOADING PHASES OF STRETCHING. MODIFIED FROM TAYLOR ET AL. 1990.	9
FIGURE 4: VISCOELASTIC COMPONENTS OF MTU AND CONNECTIVE TISSUE DIAGRAM: CONTRACTILE COMPONENT: ACTIN AND MYOSIN FILAMENTS; PARALLEL ELASTIC COMPONENTS: PERIMYSIUM, ENDOMYSIUM AND EPIMYSIUM; SERIES ELASTIC COMPONENT: TENDON AND TITIN (HILL, 1938).....	14
FIGURE 5: ON DAY 1ST OF THE MENSTRUAL CYCLE, OESTROGEN AND PROGESTERONE LEVELS ARE LOW. LOW LEVELS OF OESTROGEN AND PROGESTERONE SIGNAL THE PITUITARY GLAND TO PRODUCE FOLLICLE STIMULATING HORMONE (FSH). FSH BEGINS THE PROCESS OF MATURING A FOLLICLE. THE FOLLICLE PRODUCES MORE OESTROGEN TO PREPARE THE UTERUS FOR PREGNANCY. AT OVULATION, USUALLY AROUND DAY 12 – 14, INCREASED OESTROGEN LEVELS TRIGGER A SHARP RISE IN LUTEINIZING HORMONE (LH) FROM THE PITUITARY GLAND, CAUSING THE RELEASE OF THE EGG FROM THE FOLLICLE. THE RUPTURED FOLLICLE (CORPUS LUTEUM) NOW SECRETES PROGESTERONE AND OESTROGEN TO CONTINUE TO PREPARE THE UTERUS FOR PREGNANCY. IF THE EGG IS NOT FERTILIZED, OESTROGEN AND PROGESTERONE LEVELS DROP AND, ON DAY 28, THE MENSES BEGIN (SHOUPE AND KJOS, 2006).....	15
FIGURE 6: LENGTH – TENSION CURVE DISPLACING THE MAXIMAL TORQUE AND MAXIMAL ROM. MODIFIED FROM CABIDO ET AL. (2014).....	38
FIGURE 7: STRESS RELAXATION AND CREEP RESPECTIVELY. MODIFIED FROM CABIDO ET AL. (2014).	38
FIGURE 8: LENGTH – TENSION CURVE DISPLAYING THE S_{MTU} . MODIFIED FROM CABIDO ET AL. (2014).	39
FIGURE 9: FIRST SENSATION OF STRETCH AND RESPECTIVE VALUES FOR TORQUE AND ROM. NOTE: IMAGE IS A TYPICAL CURVE RECORDED DURING TESTS.	44
FIGURE 10: VERTICAL FORCE AND VERTICAL DISPLACEMENT OVER TIME. MODIFIED FROM BRADY ET AL. (2017).....	47
FIGURE 11: FORCE – TIME CURVE. MODIFIED FROM BRADY ET AL. (2017).	48
FIGURE 12: EXAMPLE OF CALIBRATION SERIES DILUTION RECOMMENDED FOR THE SERUM OESTROGEN ANALYSIS BY THE R&D SYSTEMS, BIO-TECHNE, MINNEAPOLIS, MINNESOTA, USA.	63
FIGURE 13: SEMITENDINOSUS ULTRASOUND CROSS-SECTIONAL AREA IMAGE. A) SKIN; B) SUBCUTANEOUS FAT; C) MUSCLE APONEUROSES. NOTE: IMAGE RECORDED DURING TESTS OF THE CURRENT THESIS.	65
FIGURE 14: ULTRASOUND IMAGE A) FAT THICKNESS B) SEMITENDINOSUS THICKNESS C) LEAN TOTAL THICKNESS. NOTE: IMAGE RECORDED DURING TESTS OF THE CURRENT THESIS.....	65
FIGURE 15: PARTICIPANT MANIPULATING THE CONTROLS: A) LEVER ARM CONTROL B) THE FIRST SENSATION OF STRETCH CONTROL (PHOTO: BÁRBARA PESSALI-MARQUES).....	67

FIGURE 16: REFLECTIVE MARKERS POSITIONED (PHOTO: BÁRBARA PESSALI-MARQUES). REFLECTIVE MARKERS ARE ON THE LEFT AND RIGHT ANTERIOR AND POSTERIOR SUPERIOR ILIAC PROCESSES, LEFT AND RIGHT LATERAL FEMORAL CONDYLES, LATERAL MALLEOLI, LATERAL MID-THIGHS, LATERAL MID SHANK, HEELS AND SECOND METATARSAL HEADS.	70
FIGURE 17: A RECONSTRUCTED MODEL FOR THE 3D-ANALYSIS. A) PARTICIPANT MARKS ON THE ANATOMICAL POINTS OF THE LOWER LIMBS. B) PIPELINE RECONSTRUCTION OF THE LOWER LIMB BONES AND SEGMENTS. C) ANTERIOR AND D) LATERAL VIEW WITH THE MOVEMENT AXIS. E) 3D INFRA-RED CAMERAS POSITIONING. NOTE: IMAGES RECORDED DURING TESTS OF THE CURRENT THESIS.	71
FIGURE 18: KINEMATIC VARIABLE DEFINITION - HIP FLEXION/EXTENSION: HIP FLEXION IS CALCULATED ABOUT AN AXIS TO PARALLEL TO THE PELVIC TRANSVERSE AXIS WHICH PASSES THROUGH THE HIP JOINT CENTRE. THE SAGITTAL THIGH AXIS IS PROJECTED ONTO THE PLANE PERPENDICULAR TO THE HIP FLEXION AXIS. HIP FLEXION IS THEN THE ANGLE BETWEEN THE PROJECTED SAGITTAL THIGH AXIS AND THE SAGITTAL PELVIC AXIS. A POSITIVE (FLEXION) ANGLE VALUE CORRESPONDS TO THE SITUATION IN WHICH THE KNEE IS IN FRONT OF THE BODY; KNEE FLEXION/EXTENSION: THE SAGITTAL SHANK AXIS IS PROJECTED INTO THE PLANE PERPENDICULAR TO THE KNEE FLEXION AXIS. KNEE FLEXION IS THE ANGLE IN THAT PLANE BETWEEN THIS PROJECTION AND THE SAGITTAL THIGH AXIS. THE SIGN IS SUCH THAT A POSITIVE ANGLE CORRESPONDS TO A FLEXED KNEE; ANKLE DORSI/PLANTAR FLEXION: THE FOOT VECTOR IS PROJECTED INTO THE FOOT SAGITTAL PLANE. THE ANGLE BETWEEN THE FOOT VECTOR AND THE SAGITTAL AXIS OF THE SHANK IS THE FOOT DORSI/PLANTAR FLEXION. A POSITIVE NUMBER CORRESPONDS TO DORSIFLEXION. PICTURE MODIFIED FROM (UNKNOWN, 2010).....	72
FIGURE 19: A) EMG ELECTRODES ON THE SEMITENDINOSUS B) EMG ELECTRODES ON THE RECTUS FEMORIS (PHOTO: BÁRBARA PESSALI-MARQUES).	74
FIGURE 20: ELECTROMYOGRAPHIC ZERO OFFSET REMOVAL. NOTE: IMAGE RECORDED DURING TESTS OF THE CURRENT THESIS. ...	75
FIGURE 21: ROOT MEAN SQUARE WITH DIFFERENT WINDOW LENGTH AND WINDOW OVERLAP TIMES. NOTE: IMAGE RECORDED DURING TESTS OF THE CURRENT THESIS.....	75
FIGURE 22: PARTICIPANTS POSITIONED WITH THE HIPS FLEXED AT 160 DEGREES. THEREAFTER, THE KNEE EXTENSION IS PERFORMED TO STRETCH THE HAMSTRINGS. FROM PESSALI-MARQUES (2015).	83
FIGURE 23: SECOND VERSION OF THE FLEXIBILITY TEST EQUIPMENT (BASTIDORES – DANCE, RESEARCH AND TRAINING ARCHIVE).	84
FIGURE 24: ILLUSTRATION OF THE EXPERIMENTAL PROCEDURES.	85
FIGURE 25: ILLUSTRATION OF THE EXPERIMENTAL DESIGN FOR THE CONTROL GROUP (PHOTOS: BÁRBARA PESSALI-MARQUES). .	86
FIGURE 26: LINEARITY OF A) LOAD CELL AND B) POTENTIOMETER. NOTE: DATA FROM TESTS OF THE CURRENT THESIS.	88
FIGURE 27: PUSH-BUTTON TO CONTROL THE ASCEND AND DESCEND MOVEMENTS OF THE LEVER; 2. THE ANKLE SUPPORT DESIGNED IN A “U” SHAPE TO MINIMISE HIP EXTERNAL ROTATION; 3. LOAD CELL (CS 15 V, LÍDER BALANÇA, ARAÇATUBA, SP, BRAZIL) TO MEASURE THE MTU’S RESISTANCE FORCE AGAINST STRETCH; 4. AMPLIFIER (STRAIN GAUGE TRANSDUCER SMOWO, RW-ST01, SHANGHAI TIANHE AUTOMATION INSTRUMENTATION Co, SHANGHAI, CHINA); 5.SUPPORT FOR THE THIGH TO AVOID HYPEREXTENSION OF THE KNEE; 6. CONTROLLER TO SIGNAL THE FSS: A TENSION IN THE HAMSTRINGS; 7. POTENTIOMETER (TT ELECTRONICS ABW1 5K +/- 10% RAPID ELECTRONICS PART NO 51-7053, ABERCYNON, UNITED KINGDOM TT) TO RECORD THE ROM; 8. ANALOGICAL/DIGITAL CONVERTER (NI USB-6008 NATIONAL INSTRUMENTS); 9. COMPUTER: DASYLAB PROGRAM 11.0 (DASYTEC DATEN SYSTEM TECHNIK GMBH, LUDWIGSBURG, GERMANY); 10. MOTOR (PARVALUX MOTOR AND RIGHT ANGLE GEARBOX MODEL BH11 8PU PM3D LWS63690/01J, PARVALUX, BOURNEMOUTH, UNITED KINGDOM); 11. STRAPS TO FIX THE LIMB 12. CUSHIONS FOR THE NECK AND LUMBAR AREAS; 13.	

ADJUSTABLE SECTIONS ACCORDING TO PARTICIPANT’S LIMB LENGTH; 14. LEVER. (PHOTOS: BÁRBARA PESSALI-MARQUES).	91
.....	91
FIGURE 28: ACQUIRED CURVES DURING THE TESTS.....	92
FIGURE 29: CONSTANT ANGLE STRETCHING. A) ROM X TIME CURVE. B) TORQUE X TIME CURVE. MODIFIED FROM CABIDO ET AL. (2014).....	93
FIGURE 30: CONSTANT TORQUE STRETCHING. A) ROM X TIME CURVE. B) TORQUE X TIME CURVE. MODIFIED FROM CABIDO ET AL. (2014).....	94
FIGURE 31: ILLUSTRATION OF THE EXPERIMENTAL PROCEDURES	103
FIGURE 32: ILLUSTRATION OF THE TESTS’ ORDER	103
FIGURE 33: ROM _{MAX} AVERAGE AND STANDARD DEVIATION FOR THE COMPARISONS BETWEEN GROUP: NON-DANCERS (NN) X DANCERS (DCN); AND, LOWER LIMB DOMINANCE: DOMINANT LOWER LIMB (D LL) X NON-DOMINANT LOWER LIMB (ND LL). *STATISTICAL SIGNIFICANCE DIFFERENCE BETWEEN THE LIMBS. #STATISTICAL SIGNIFICANCE DIFFERENCE BETWEEN THE GROUPS.	106
FIGURE 34: TORQUE _{MAX} AVERAGE AND STANDARD DEVIATION FOR THE COMPARISONS BETWEEN GROUP: NON-DANCERS (NN) X DANCERS (DCN); AND, LOWER LIMB DOMINANCE: DOMINANT LOWER LIMB (D LL) X NON-DOMINANT LOWER LIMB (ND LL). #STATISTICAL SIGNIFICANCE BETWEEN THE GROUPS.	107
FIGURE 35: FSS _{ROM} AVERAGE AND STANDARD DEVIATION FOR THE COMPARISONS BETWEEN GROUP: NON-DANCERS (NN) X DANCERS (DCN); AND, LOWER LIMB DOMINANCE: DOMINANT LOWER LIMB (D LL) X NON-DOMINANT LOWER LIMB (ND LL). #STATISTICAL SIGNIFICANCE BETWEEN THE GROUPS.	108
FIGURE 36: ENERGY AVERAGE AND STANDARD DEVIATION FOR THE COMPARISONS BETWEEN GROUP: NON-DANCERS (NN) X DANCERS (DCN); AND, LOWER LIMB DOMINANCE: DOMINANT LOWER LIMB (D LL) X NON-DOMINANT LOWER LIMB (ND LL). #STATISTICAL SIGNIFICANCE BETWEEN THE GROUPS.	109
FIGURE 37: EMG _{RF} AVERAGE AND STANDARD DEVIATION FOR THE COMPARISONS BETWEEN GROUP: NON-DANCERS (NN) X DANCERS (DCN); AND, LOWER LIMB DOMINANCE: DOMINANT LOWER LIMB (D LL) X NON-DOMINANT LOWER LIMB (ND LL). * STATISTICAL SIGNIFICANCE BETWEEN THE LIMBS. #STATISTICAL SIGNIFICANCE BETWEEN THE GROUPS.....	111
FIGURE 38: VISUAL ANALOGUE SCALE COMPARISON BETWEEN GROUPS.	116
FIGURE 39: ILLUSTRATIVE FIGURE OF THE PROCEDURES. CMJ: COUNTERMOVEMENT JUMP, SJ: SQUAT JUMP. MOST FLEXIBLE LEG = INTERVENTION CONDITION, LEST FLEXIBLE LEG = CONTROL CONDITION.	130
FIGURE 40: ILLUSTRATIVE FIGURE OF THE TESTS’ ORDER (PHOTOS: BÁRBARA PESSALI-MARQUES)	130
FIGURE 41: ROM _{MAX} AVERAGE AND STANDARD DEVIATION FOR THE COMPARISONS BETWEEN CONDITIONS: TRAINING (T) X CONTROL (C); AND, TIME: PRE-TEST X POST-TEST. * STATISTICAL SIGNIFICANCE DIFFERENCE BETWEEN THE CONDITIONS. # STATISTICAL SIGNIFICANCE DIFFERENCE BETWEEN TIME.....	133
FIGURE 42: TORQUE _{MAX} AVERAGE AND STANDARD DEVIATION FOR THE COMPARISONS BETWEEN CONDITIONS: TRAINING (T) X CONTROL (C); AND, TIME: PRE-TEST X POST-TEST. * STATISTICAL SIGNIFICANCE DIFFERENCE BETWEEN THE CONDITIONS. # STATISTICAL SIGNIFICANCE DIFFERENCE BETWEEN TIME.....	134
FIGURE 43: SJ FORCE _{PEAK} AVERAGE AND STANDARD DEVIATION FOR THE COMPARISONS BETWEEN CONDITIONS: TRAINING (T) X CONTROL (C); AND, TIME: PRE-TEST X POST-TEST. * STATISTICAL SIGNIFICANCE DIFFERENCE BETWEEN THE CONDITIONS. # STATISTICAL SIGNIFICANCE DIFFERENCE BETWEEN TIME.....	137

FIGURE 44: JUMP PHASES DURING WHICH ANGLES WERE ANALYSED – A) PREPARATORY SQUAT: THE LOWEST POINT ACHIEVED IN THE ECCENTRIC PHASE DOWNWARDS, B) TAKE-OFF PHASE: THE POINT AT WHICH NO FORCES WERE REPORTED BY THE FORCE PLATE, C) LANDING: THE PHASE AT WHICH THE FORCE PLATE RECORDS THE FORCE FOLLOWING FROM THE AERIAL PHASE OF THE JUMP, D) LANDING SQUAT: THE LOWEST POINT ACHIEVED IN THE ECCENTRIC PHASE DOWNWARDS BREAKING FROM THE JUMP. (FIGURE – PRODUCED BY BÁRBARA PESSALI-MARQUES).....	151
FIGURE 45: PHASES WHERE THE ANGULAR VELOCITY (RED DOTS) WAS CALCULATED FOR ALL THE EVALUATED JOINTS: A) ECCENTRIC PHASE OF THE JUMP, B) CONCENTRIC PHASE OF THE JUMP (ILLUSTRATIVE FIGURE PRODUCED BY BÁRBARA PESSALI-MARQUES).....	151
FIGURE 46: ANKLE ANGLE VARIATION DURING CMJ PHASES.....	157
FIGURE 47: KNEE ANGLE VARIATION DURING CMJ PHASES.....	158
FIGURE 48: HIP ANGLE VARIATION DURING CMJ PHASES.....	158
FIGURE 49: ANKLE ANGLE VARIATION DURING SJ PHASES.....	159
FIGURE 50: KNEE ANGLE VARIATION DURING SJ PHASES.....	160
FIGURE 51: HIP ANGLE VARIATION DURING SJ PHASES.....	161
FIGURE 52: ILLUSTRATION OF THE TWO-DAY WINDOW FOR EACH PHASE OF THE MENSTRUAL CYCLE IN A REGULAR 28-DAY CYCLE LENGTH.....	179
FIGURE 53: ILLUSTRATIVE FIGURE OF THE FAMILIARISATION AND TEST SESSIONS.....	181
FIGURE 54: ILLUSTRATIVE FIGURE OF THE TESTS' ORDER. (PHOTOS: BÁRBARA PESSALI-MARQUES).....	181
FIGURE 55: AVERAGE AND STANDARD DEVIATION OF OESTROGEN, PROGESTERONE AND RELAXIN AT FOLLICULAR, OVULATORY AND LUTEAL PHASES OF THE MENSTRUAL CYCLE.....	185
FIGURE 56: ROM _{MAX} COMPARISONS BETWEEN LIMBS AND MENSTRUAL CYCLE PHASES. *: STATISTICAL SIGNIFICANCE BETWEEN LIMBS.....	188
FIGURE 57: TOTAL PASS ACROSS THE MENSTRUAL CYCLE. *: STATISTICAL SIGNIFICANCE BETWEEN THE PHASES.....	188
FIGURE 58: PASS PHYSIOLOGICAL ANXIETY COMPARISON ACROSS THE MENSTRUAL CYCLE. *: STATISTICAL SIGNIFICANCE BETWEEN THE PHASES.....	189
FIGURE 59: MENSTRUAL CYCLE LENGTH OF ONE PARTICIPANT.....	195

List of Equations

EQUATION 1: STIFFNESS CALCULATION.	9
EQUATION 2: S_{MTU} CALCULATION.	10
EQUATION 3: ACTIVE STIFFNESS CALCULATION.	13
EQUATION 4: S_{MTU} = STIFFNESS, Δ = VARIATION.	24
EQUATION 5: GRAVITY CORRECTION EQUATION.	89

Acknowledgements

Eu gostaria de agradecer ao "PhD". Cheguei cheia de ideias, sonhos, expectativas e "você" me fez sentir sozinha, vazia, nua... livre. Tive que aprender a abrir mão, aceitar que o mundo não é justo, mas que não posso mudar tudo sozinha. Isso que me fez sentir pequena, impotente. Então comecei a reparar em detalhes, para encontrar paz. Uma flor crescendo no meio do concreto, o cheiro de ar úmido, o verde da grama.

Parei de sonhar, mas comecei a viver o presente! Minha ansiedade não me incomoda mais como antes. Eu desisti de acreditar ou esperar das pessoas; agora elas me surpreendem.

Depois de tantas lágrimas eu estou lavada, nova. Eu aumentei meu conhecimento sim, mas aumentei ainda mais minha sabedoria. O que é muito mais importante.

Gostaria de agradecer à Deus, à unidade e todas as Suas partes:

Robson Marques dos Santos e Soraya Queiroz Pessali obrigada por aceitarem ser meus pais nesta vida e Gustavo Pessali Marques, meu irmão. Não há trabalho mais difícil do que compartilhar uma vida. Obrigada, Chris Huston, por pegar o trem.

Obrigada, Dra. Gladys Onambele-Pearson, Dr. Adrian Burden e Dr. Chris Morse por todas as lições.

Obrigada Bastidores, minha equipe e todos os bailarinos e artistas que tocamos ou ainda tocaremos, de qualquer forma que seja, por serem o propósito.

Obrigada Angeliki Vasaka, Dra. Marie Chollier, Dawn O'Down, Dr. Praval Khanal, Lingxiao He, Dra. Mariateresa Tassinari, Sofie Cataldo, Ana Pal e Ian Clare por fazerem Crewe um lugar habitável, com todos os experimentos, jantares, filmes e vinho.

Obrigada Regina Amaral de Freitas, Dra. Fabiola Medeiros, Camila Bicalho, Fabiola Keesen, Bárbara de Carvalho, Débora Pessali, Luciana Bruschi, Ana Carolina Maia, Matheus Milanes, Dr. Aidan Fitzgerald, Dr. Mauro Heleno Chagas, Dr. Gustavo Peixoto por todas as leituras, discussões e apoio; alguns acadêmicos, outros nem um pouco.

Obrigada CAPES pelo financiamento, obrigada Rede Brasil-UK por todo o trabalho realizado, mas principalmente por todos os amigos conquistados.

Nada é por acaso, construímos nossa própria realidade e vivemos o que devemos. Se queremos pular mais alto, não podemos ser completamente flexíveis, mas qual é a rigidez necessária? Qual é o ponto ideal que nos permite ser suficientemente flexíveis para alcançar mais longe, mas rígidos o suficiente para nos impulsionar ao mesmo tempo?

O PhD é muito mais do que um título ou um projeto, é um passo de crescimento tão emocional e espiritual quanto intelectual.

Meu PhD tem como objetivo encontrar o equilíbrio. Meu PhD é sobre rigidez, no corpo e na vida.

I would like to thank "the PhD". I arrived full of ideas, dreams, expectations and "you" made me feel alone, empty, naked, thus... free. I had to learn to let it go, to accept, that the world is not fair, but that I cannot change it all by myself. This made me feel small, impotent. Then I started to look at the details to find some peace. Like a flower growing in a concrete crack, the smell of humid air, the green of the grass.

I stopped dreaming but I started living in the present! So, my anxiety does not bother me like before. I gave up believing or expecting from people; now they surprised me.

After all my tears I am washed, new. I improved my knowledge, but I improved my wisdom much more. Far more important.

I would like to thank God, the unity, and all His parts:

Robson Marques dos Santos and Soraya Queiroz Pessali thank you for accepting being my parents in this life and Gustavo Pessali Marques, my brother. There is no harder job than sharing a life. Thank you, Chris Huston, for getting the train.

Thank you, Dr Gladys Onambele-Pearson, Dr Adrian Burden and Dr Chris Morse for all the lessons.

Thank you Bastidores, my team and all the dancers and artists we have ever touched or that we still will, at any way, for being the purpose.

Thank you Angeliki Vasaka, Dr Marie Chollier, Dawn O'Down, Dr Praval Khanal, Lingxiao He, Dr Mariateresa Tassinari, Sofie Cataldo, Ana Pal and Ian Clare for making Crewe a liveable place, with all the experiments, dinners, movies and wine.

Thank you, Regina Amaral de Freitas, Dr. Fabiola Medeiros, Camila Bicalho, Fabiola Keesen, Bárbara de Carvalho, Débora Pessali, Luciana Bruschi, Ana Carolina Maia, Matheus Milanes, Dr Aidan Fitzgerald, Dr Mauro Heleno Chagas, Dr Gustavo Peixoto for all the readings, discussions and support; some academic, some not academic at all!

Thank you, CAPES, for the funding, thank you, Brazil-UK Network, for all the work done, but mainly for all the friends made.

Nothing is a coincidence; we build our own reality and live what we must. If we want to jump higher, we cannot be completely flexible, but what is the necessary rigidity? What is the optimal point that allow us to be flexible enough to reach further but stiff enough to impulse ourselves at the same time?

This PhD is much more than a tittle or a project, it is a growth path, as emotional and spiritual as intellectual.

My PhD aims to find the balance. My PhD is about stiffness, in the body and in life.

Abstract

Flexibility and jump are crucial capabilities for dancers but reaching good performance in both is a challenge. Given that muscle-tendon stiffness (S_{MTU}) might affect both these capabilities and that muscle structure and concentration of female hormones across the menstrual cycle may affect S_{MTU} , this thesis aimed to determine the factors that might affect S_{MTU} and, therefore, physical performance in female dancers, especially through the menstrual cycle. A piece of equipment to measure and train flexibility in highly flexible participants was developed and validated. Then, fifteen young adult dance students under oral contraception, eleven dance students without contraception and twenty non-dancers without contraception completed several laboratory-based tests. Participants underwent semitendinosus and rectus femoris ultrasound imaging, flexibility and vertical jump tests including electromyography, kinematics, and pain mixed-method assessment. Participants also provided serum/saliva samples on test days, including ovulatory, follicular and luteal phases. An intervention involving stretching the most flexible limb allowed evaluation of limb asymmetries and impact on function. Results showed no statistical structural and functional differences between dancers and non-dancers. Asymmetries in flexibility, but S_{MTU} , between limbs, were found for all groups. Those asymmetries appear to not influence jump performance. Four-series of passive constant torque stretch was not sufficient to cause or increase any asymmetry or to affect S_{MTU} . Stretching did not change jump height, muscle activation and kinematics of vertical jumps. Dancers presented irregular menstrual cycle with the change in hormone across the phases being associated with changes in key outcome variables. Thus, oestrogen and relaxin appear to be positively correlated to muscle laxity while progesterone is positively correlated to S_{MTU} . This thesis' results will provide data for the development of training strategies to improve performance and potentially decrease injuries in dancers. Additionally, contributing to research on hormonal factors in female performance and, therefore, women's health.

Introduction

"A Alma e a Matéria

*Procuro nas coisas vagas ciência!
Eu movo dezenas de músculos para sorrir...
Nos poros a contrair, nas pétalas de Jasmin
Com a brisa que vem roçar da outra margem do mar...*

*Procuro na paisagem... cadência!
Os átomos coreografam a grama do chão.
Na pele braile pra ler, na superfície de mim.
Milímetros de prazer, quilômetros de paixão...*

*Vem pra esse mundo, Deus quer nascer!
Há algo invisível e encantado entre eu e você.
E a alma aproveita pra ser a matéria e viver...
E a alma aproveita pra ser a matéria e viver!"*

Marisa Monte

"Soul and Matter

*Through the vague things I look for Science!
I move dozens of muscles just to smile...
In the pores contracting, In the Jasmine petals
With the breeze rustling, from the other side of the sea...*

*At the landscape I look for... Cadence!
The atoms choreograph the grass of the ground.
On the skin; braille to read. On the surface of me.
Millimetres of pleasure, miles of passion...*

*Come to this world. God wants to be born!
There is something invisible and enchanted between you and I
And the soul takes advantage to be the matter to live ...
And the soul takes advantage to be the matter to live!"*

Marisa Monte

Many sport modalities require flexibility or strength components; in dance, both are crucial. More specifically, within dance jumps, such as *grand jetés*, *grand jetés `a la second* and *sissones*¹, the joints range of motion (ROM) plays an important role (Prati and Prati, 2006, Scheper et al., 2012) in perfecting the aesthetics component (Karloh et al., 2010, Tajet-Foxell and Rose, 1995), while strength is essential to increase the jump height (Farley et al., 1991). Also considering that dance choreographers are increasingly adopting an athletic approach to dance movements (Koutedakis et al., 2007), the optimal development of a great dance career will require a strong and flexible dancer to perform a range of different movements (Angioi et al., 2009b, Bennell et al., 1999) in addition to the need to decrease injury risk. Yet, the two capabilities appear to require opposing characteristics in terms of muscle-tendon unit (MTU) stiffness. Therefore, physical training, given the need to concomitantly be both strong and flexible, remains a challenge for trainers and dancers (Brughelli and Cronin, 2008b, Shrier, 2004a).

In previous studies, the maximal range of motion (ROM_{Max}) reached in a joint has been used to measure flexibility (Chagas et al., 2008, Pereira, 2016); while the maximum jump height has been used to infer the strength of the MTU (Cordova and Armstrong, 1996, Harley, 2002). Both, ROM_{Max} and jump height, may be influenced by the MTU stiffness (Farley et al., 1991, Brughelli and Cronin, 2008b), which is defined as the degree of resistance offered by the MTU tissues to a change in length (Fouré et al., 2011). Considering that, the term “stiffness” describes a property that may be applied to all viscoelastic material, including the MTU, in this study the MTU stiffness will be named S_{MTU} , which can be passive (when a relaxed muscle resists to changes in length, reflecting, therefore, the series elastic components behaviour) or active (when an active muscle resists to changes in length, reflecting, therefore, participation of the muscle’s contractile elements) (Morgan, 1977). In addition, the MTU components, the tendon and the muscle, may also be segregated in the description of their characteristics as each may present different properties. Therefore, the terms tendon stiffness (S_{Ten}) and muscle stiffness (S_{Mus}) respectively, will also be employed. The definitions proposed in this program of studies are aimed to decrease possible confusion and improve clarity as suggested by (Latash and Zatsiorsky, 2015).

¹ For a detailed explanation and illustration of steps (e.g. *grand jetés*, *grand jetés `a la seconde*, and *sissones*) see Appendix A page 267.

The S_{MTU} may also influence other athletic variables, such as the rate of force development and elastic energy storage and utilization in sprint kinematics (Brughelli and Cronin, 2008b). Numerous types of equipment and techniques can be utilised to assess and analyse S_{MTU} , such as video analyses, force plates, kinematic arms, contact mats and pressure sensors (Brughelli and Cronin, 2008b) along with the observation of the length-tension relationship (Blackburn et al., 2004). The majority of these techniques are indirect and assess how a joint responds to external forces to facilitate a displacement (Fouré et al., 2011).

Previous research in jumping has shown that greater mechanical S_{MTU} is beneficial to maximise jump height (Farley et al., 1991). Cornu et al. (1997) found an increase in passive S_{MTU} and a decrease in active S_{MTU} following seven weeks of power training. The authors hypothesised that the passive S_{MTU} increase is beneficial for the rate of force development and the active S_{MTU} decrease is advantageous for storing and re-using elastic energy. Corroborating this assumption, Seyfarth et al. (2000) found an enhancement to the rate of force development in stiffer MTU, which is advisable for movements that require maximum force production over a short time.

Research concerned with flexibility has investigated S_{MTU} , which is defined as the resistance to elongation and is correlated to the MTU capacity of absorbing potential elastic energy (from now on referred to as 'energy') (Marshall et al., 2011, Cabido et al., 2014, Blazevich et al., 2012) (Figure 1). Therefore, any decrease in torque (force applied outside the centre of rotation of the joint) aiming to stretch the MTU (Weppler and Magnusson, 2010) in conjunction with an unchanged ROM, following an intervention, may indicate a decrease in the resistance of stretching offered by the MTU structures (Herda et al., 2011a, Hutton, 1992).

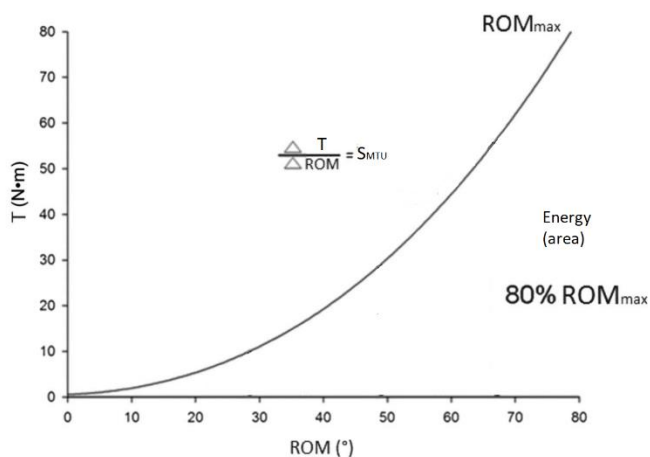

Figure 1: S_{MTU} can be calculated through the change in the resistance torque (T) divided by the change in ROM. Any portion of the slope may be used to calculate the passive S_{MTU} , using a tangent line to the curve (Pearson and Onambele, 2005, Pearson and Onambélé, 2012, Pearson and Onambele, 2006). Modified from Cabido et al. (2014).

On one hand, the decrease in the MTU resistance torque may be beneficial to dancers when raising their limbs (e.g. *grand battements* and *développés*)², as the agonist muscles have less resistance to overcome from the antagonist muscles to achieve the same ROM. On the other hand, a stiffer MTU may also be beneficial as it absorbs more energy that can be utilised within subsequent movements (e.g. jumps) (Figure 2).

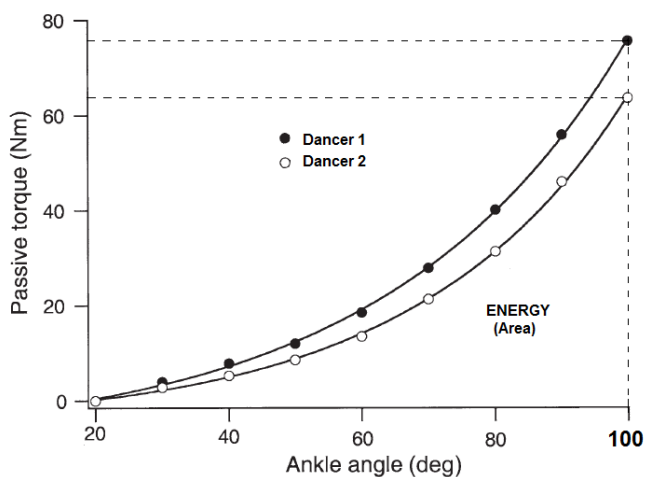

Figure 2: Difference in S_{MTU} between two dancers. Dancer 1 needs greater passive torque to move the limb and achieve the same ROM as dancer 2, however, is able to absorb more energy that could be used in jumps. Note: the curve is a theoretical illustration.

² For a detailed explanation and illustration of steps (e.g. *grand battements* and *développés*) see Appendix B page 268.

Studies concerned with the relationship between flexibility and strength have shown a decrease in jump height following flexibility training protocols (Herda et al., 2008, Morrin and Redding, 2013). This decrease may be due to a decrease in S_{MTU} (Costa et al., 2010, Herda et al., 2010b) and therefore a decrease in the elastic energy absorbed.

Conflicting evidence in the literature showed that both an increase and a decrease in S_{MTU} can lead to improvements in performance in different types of modalities (Fouré et al., 2011). Despite the controversy on the optimal S_{MTU} required for movements, such as running and jumping (Brughelli and Cronin, 2008b), a mechanical modelling study suggested that there is an optimal mechanical S_{MTU} for long jumping (Seyfarth et al., 2000); this assumption advocates a possible extrapolation to optimal S_{MTU} for raising legs in a high ROM and jumping high.

No published studies (to the author's knowledge) comparing S_{MTU} and performance in dancers were found. Shrier (2004b) offered two hypotheses still to be tested: Firstly, a lower S_{MTU} may be advantageous for dancers, as it may help to raise their limbs or secondly, a greater S_{MTU} may enhance jump performance through more potential energy stored and utilised, along with the additional potential of injury protection. However, dancers are required to concurrently perform jump and flexibility movements. Therefore, not only is there an argument for both a high and lower S_{MTU} to benefit dancers, but it may be that rather a balance of the two extremes is required. Hence the importance to study the alluded impact of S_{MTU} in dance performance; to identify a possibly optimal S_{MTU} in dancers.

The debate continues around the factors that may influence the S_{MTU} . Stable cross-links between actin and myosin filaments and the non-contractile proteins of the endosarcomeric and exosarcomeric cytoskeletons surrounding since the muscle fibre to the muscle belly may also affect stiffness. In both cases, the non-contractile proteins are referred to as 'series elastic element' (Gajdosik, 2001, Herda et al., 2009). Additional factors have been identified, such as the changes the perimysium (Gajdosik, 2001), the redistribution of water and polysaccharides in the extracellular matrix surrounding the collagen fibres (Mcnair et al., 2001), the modification in the tendon compliance (Kubo et al., 2001a), in the length of the

muscular fascicle (Fowles et al., 2000, McMahon et al., 2014) or in the cross-sectional area of the muscle.

The circulating hormonal levels of oestrogen and/or progesterone may also be one of those factors (Uldbjerg and Ulmsten, 1990); potential effects of hormone fluctuation across the MCP appear to affect tendon laxity, affecting S_{MTU} and ultimately MTU functional characteristics (Heitz et al., 1999). Aligned to MCP modifications is the perception of pain. Given that oestrogen might influence sensory processes (Tommaso, 2011) and therefore the ability to tolerate pain, the alteration in pain sensation might affect flexibility levels, as pain tolerance is one of the MTU responses to stretch (referred as the sensory property of MTU) (Chagas et al., 2016).

Although pain tolerance plays a role in flexibility training (Chagas et al., 2016), no studies, in the best of the author's knowledge, were found accessing the modification of pain across the MCP influencing flexibility and MTU structural and functional characteristics. Still regarding pain sensation, in practical applications, dancers often report different degrees of pain sensation between limbs when stretching. Even though dance is considered a bilateral activity, there is evidence that dancers might train one side to the detriment of the other side (Sadeghi et al., 2000, Kimmerle and Science, 2010). Possible asymmetries in flexibility between legs could affect S_{MTU} (Blazevich et al., 2012), and maybe, different force production between legs during jumps. In addition, possible asymmetries in flexibility may be enhanced if the pain tolerance varies between legs, given that more intensity of stretch could be applied in the leg with greater pain tolerance (Chagas et al., 2008). Therefore, it is justifiable to assign importance to assess both pain and stretch variables in each leg separately.

Considering that flexibility and strength components could be influenced by S_{MTU} (Brughelli and Cronin, 2008b), and S_{MTU} being affected by many factors including the key menstrual cycle hormones (Onambélé et al., 2007b), it is necessary to determine whether the different phases of the menstrual cycle influence jumps and flexibility performance in dancers. Indeed, jump and flexibility capacities are prerequisites for numerous dance movements and, as such, are crucial for dancers' performance. Therefore, it would also be opportune to

determine whether there is an optimum S_{MTU} associated with the best performance in both movements simultaneously. Moreover, highlighting any interaction between MTU structural and functional characteristics, against the menstrual cycle phases (MCP) will help to predict any modification in dance performance. Ultimately, the current body of research will provide data for the development of training strategies to improve performance and potentially decrease injury risks in dancers. Additionally, this will contribute to the research on hormonal factors in female performance and, therefore, women's health.

The following section will review the literature on stiffness as a material property, its influence on MTU and its components S_{Mus} and S_{Ten} . Furthermore, the factors that might influence S_{MTU} are also expanded upon.

1. Narrative Literature Review

*Eu me liberto de toda a ilusão que o medo possa criar.
Eu construo minha própria realidade.*

*I free myself from any illusion that fear may create.
I build my own reality.*

1.1 Stiffness

Stiffness is the resistance force of an elastic body against deformation and may be technically defined as “force per unit deformation” (Latash and Zatsiorsky, 2015). This deformation or displacement (e.g. an elongation, rotation, bending, slipping) is according to the properties of the material and the magnitude force applied. When one structural element deforms more than another does for the same applied force, it is considered less stiff.

Stiffness can be calculated through the formula where k = stiffness (N/m), F = applied force (N) and δ = extension, deflection (m).

$$k = F/\delta$$

Equation 1: Stiffness calculation.

If a determinate tension F is necessary to elongate an elastic material to a length δ , the area under the graph of length-tension represents the energy, or, the work performed to stretch the material. Accordingly, the total energy measured by the area under the graph represents the energy that has been stored as elastic potential energy, which equals to one-half times the material constant multiplied by the square of the extension. However, some of the initial energy might be transformed into heat. Therefore, there is a difference in the amount of energy invested in the loading and the remaining energy in the unloading curves (hysteresis loop) (Figure 3). Nevertheless, if stiffness is greater (k in the equation), the elastic potential energy is greater.

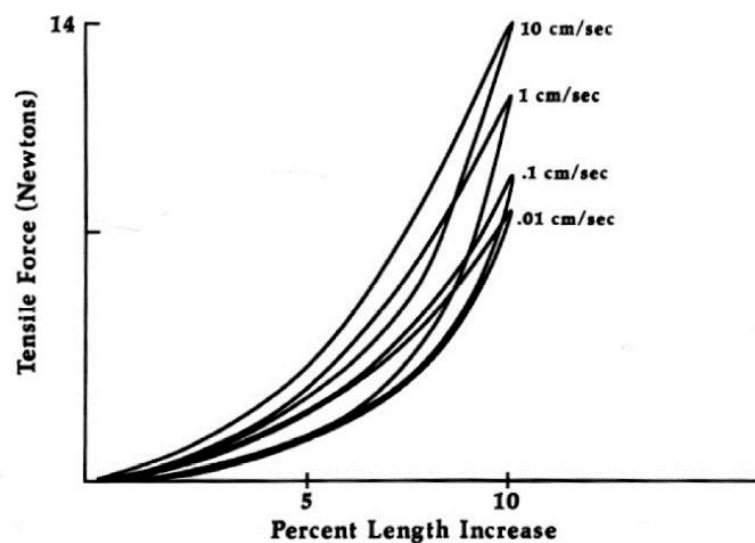

Figure 3: Tendon hysteresis during the loading and unloading phases of stretching. Modified from Taylor et al. 1990.

For rotational movements, such as the force applied for stretching the MTU, the corresponding expression is expressed in the Equation 2, where S_{MTU} = Muscle-tendon unit stiffness ($N/^\circ$), $\Delta torque$ = variation in the moment of force or joint torque (force x length) (N), ΔROM = variation in the range of motion ($^\circ$) (Latash and Zatsiorsky, 2015).

$$S_{MTU} = \frac{\Delta torque}{\Delta ROM}$$

Equation 2: S_{MTU} calculation.

A stiffer material allows a small amount of deformation per unit of force; therefore, it is less compliant. The inverse property of stiffness is known as compliance and describes the ratio of variation in deformation to tension change. Passive bodies, such as the MTU when relaxed, maintain constant length in the absence of external forces. However, beyond the aforementioned forces, the MTU is able to generate force itself, internally, acting as an active body (Latash and Zatsiorsky, 2015). The analysis of the constituents of the force production is needed for the understanding of the MTU response to external or internal forces production.

Even though the response to flexibility and strength training protocol in humans should be performed considering the response of the MTU as a whole system, studies were performed analysing the contribution and differences between the tendon and muscle properties (Arndt et al., 1988, Morse et al., 2008, Biewener and Roberts, 2000), once the separation of muscle and tendon components is didactically and scientifically important to enhance our understanding of the whole MTU.

The tendons are composed of regular fibrous connective collagen fibres lined up in parallel. The matrix gives the tissue according to the concentration of cells or fibres. The protein fibres, found in the tendons, are mainly the reticular type. The tendons are responsible for the transmission of tensile force, and in some cases, energy storage and release during physical exertion such as locomotion (Maganaris and Paul, 2002). The S_{Ten} can influence the relationship between active and passive force, and velocity in muscle; a stiffer tendon transfer forces from the muscle to the bone more rapidly than the less stiff tendon (Onambélé et al., 2007b), which might help with force production and movement execution. Due to the rapid tension changes and, perhaps the relay of sensory feedback to the central

nervous system regarding muscle length and tension, a stiffer tendon may be advantageous for performing refined movements (Ettema, 1996, Ettema, 2001).

The length-tension relationship is also affected by the tendon properties; when the tendon is less stiff (i.e. more compliant), the amount of filament overlap within the associated muscle lessens, leading to lower ability to generate external forces (Pearson and Onambele, 2005). Koceja et al. (1991) found a lesser isometric strength and greater half-relaxation time in dancers after a mechanical stimulus in the Achilles tendon when compared to non-dancers, suggesting that due to the greater compliance in the dancers' group the tensile transference was affected. This thus supports previous work in closed-loop muscle performance tests (Pearson and Onambele, 2006).

Changes in the pennation angle can be caused by a modification in the S_{Ten} . A stiffer tendon may provide a decrease in the fibre angle as the muscle fibres are stretched (Onambele-Pearson and Pearson, 2007, Hicks et al., 2013). This change in angle affects the effective force that is a product between the cosine of the angle of pennation and the muscle force. The rate of force development is influenced by the time between muscle activation and muscle force production or the electro-mechanical delay (Grosset et al., 2009). Similarly, compliant tendons would delay the action of muscle spindles, the mechanoreceptors responsible for the stretch reflex. The H-reflex was found to be smaller in dancers when compared to other sport modalities and non-trained participants. Therefore, they were able to tolerate a greater tension before the stretch reflex was stimulated (Nielsen et al., 1993), however, in an explosive effort, where forces are required to be generated rapidly, this might be a problem.

Movement economy can also be modulated by tendon stiffness, as energy may be stored and released during movement. Muscle activation during lengthening (eccentric action) stretches the tendon accumulating elastic potential energy that is released during the concentric action (Witvrouw et al., 2004, Kawakami et al., 2002). The muscle is responsible for the tension generation to change the skeleton position causing movement. The tension generation is due to actin and myosin; contracting proteins. The third protein in the

sarcomere is the titin, responsible for the elasticity together with the fasciae (endomysium, perimysium and epimysium).

To understand the response of the MTU is necessary to understand its structure and composition. The MTU exhibit both elastic and viscous properties, as such is considered a viscoelastic material. Elasticity is related to an ability to return to an original length after loading (Weppeler and Magnusson, 2010). Elasticity is tension-dependent and potential energy is accumulated during elongation (energy is stored). Viscosity is related to the accommodation, which is when the material retains its new shape/size. It is time-dependent and absorbs energy. Viscoelastic materials will tend to deform and return to its original shape in a non-linear manner.

Passive elements of the MTU also play a role in its behaviour, including tendon, ligaments, fasciae, cartilage, bones, skin and muscles (when relaxed) (Latash and Zatsiorsky, 2015). The passive S_{MTU} , which represents the resistance to changes in length, would, therefore, represent the MTU passive mechanical properties (Herda et al., 2011a, Ryan et al., 2008b). For as much as any stiff material would require greater forces up to mechanical failure (Chang et al., 2013), one could hypothesise that a stiffer muscle would offer more protection to the muscles against certain types of injuries (Blackburn et al., 2004). In the case of a stiffer system, forces are transferred to the contractile tissue with a small amount of energy being absorbed by the tendon (Safran et al., 1989). Conversely, in a less stiff system, if the contractile components are active at a high level, the tendon tissue can absorb great amount energy, thereby, reducing trauma to muscle fibres. Notwithstanding this, the ability of a muscle to absorb energy is dependent on both the active (muscles when active) and the passive elements of the MTU coupled (Witvrouw et al., 2004). However, this relationship between S_{MTU} and injury is poorly understood in the literature.

There is one main difference between the properties of passive and active structures. While for passive structures, an external force is applied, in active objects (such as active muscles) the torque (force) and angle (length) can be changed independently. Therefore, the length-tension relation can only make sense if both the level of muscle activation and its time course are specified. Given that the muscle activation level, however, depends on peripheral

receptor sensitives to both muscle force and length, finding the real participation of each structure becomes challenging (Latash and Zatsiorsky, 2015).

While the passive S_{MTU} is calculated using the same aforementioned formula to calculate stiffness, the active angular stiffness can be calculated using the Equation 3, where AS = active stiffness, m = total system mass, r = system radius, f = damped frequency of oscillation (the decrease in the amplitude of vibration lost due to friction between the oscillating body and the particles in the air) (Blackburn et al., 2004).

$$AS = 4\pi^2mr^2f^2$$

Equation 3: Active stiffness calculation.

Blackburn et al. (2004) examined the relationship between active extensibility, and passive and active S_{MTU} of the knee flexors, as well as the relative contributions of active extensibility and passive S_{MTU} to active S_{MTU} . The authors found that the active extensibility and passive S_{MTU} exhibited low and moderate positive relationships with active S_{MTU} , respectively. The cross-bridge formation dominated the active S_{MTU} response as cross-bridges detach and reform over relatively larger magnitude length changes. A moderate relationship was found between active S_{MTU} and extensibility, by which higher levels of extensibility were associated with lower levels of active S_{MTU} . They suggested that greater extensibility might predispose an individual to insufficient passive and active S_{MTU} , possibly limiting the dynamic restraint capabilities about a joint.

Despite the challenge that is finding an optimum S_{MTU} , which would benefit both jump and flexibility performances concomitantly, several factors are suggested to affect S_{MTU} . The circulating hormonal levels of oestrogen and/or progesterone (Uldbjerg and Ulmsten, 1990) and participants' sex may be two of those factors, followed by the stable cross-links between the actin and myosin filaments directly (series elastic component), the noncontractile proteins of the endosarcomeric and exosarcomeric cytoskeletons (parallel elastic component), and the deformation of the connective tissues located within and surrounding the muscle belly (parallel elastic component) (Herda et al., 2009) Figure 4.

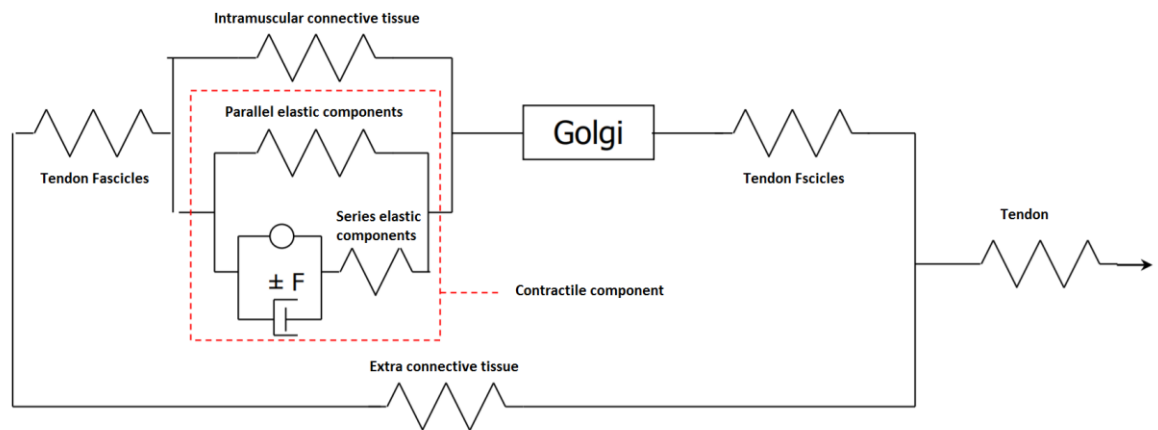

Figure 4: Viscoelastic components of MTU and connective tissue diagram: Contractile component: actin and myosin filaments; parallel elastic components: perimysium, endomysium and epimysium; series elastic component: tendon and titin (Hill, 1938).

This body of research will explore some of the factors that may affect S_{MTU} and consequently the performance in flexibility and jump movements in dancers. The following sections will detail the influence of each one of these factors on S_{MTU} .

1.1.1 Factors that may affect S_{MTU}

1.1.1.1 The menstrual cycle

The menstrual cycle is the scientific name given to the physiological alterations that occur in fertile women, which is a result of variations of blood concentrations of female hormones, especially oestrogen and progesterone. The hormones are chemical messengers that regulate the activity of cells and tissues in various organs of the body, therefore, it is essential to good health and a feeling of well-being. The menstrual cycle starts on the first day of menses and lasts until the first day of the next menses (Jukic et al., 2007). The beginning of a menses is the first of approximately two consecutive days of bleeding, in which at least one is more intense than spotting (Jukic et al., 2007). The menstrual cycle is divided into three phases: follicular, ovulatory and luteal (Bell et al., 2014b, Teixeira et al., 2012a). The follicular phase lasts from menses to ovulation (Frankovich and Lebrun, 2000), being approximately three to seven days after the beginning of the menstrual cycle. The levels of oestrogen and progesterone are expected to be low (Frankovich and Lebrun, 2000, Heitz et al., 1999, Shultz et al., 2004b) and the ovulation may be detected by an ovulation kit. The ovulation is when the egg (or two eggs in the case of fraternal twins) is released by one of the ovaries due to suppression of the gonadotrophins secretion (Teixeira et al., 2012a, Chan

et al., 2001). The ovulation occurs 24 to 28 hours after the oestrogen surge and it is followed by the luteal phase (Frankovich and Lebrun, 2000), which lasts up to the start of menses, within approximately seven-days after ovulation, if the menstrual cycle is regular and based on an average of 28-days. A peak of progesterone is expected in this phase (Karageanes et al., 2000) (Figure 5).

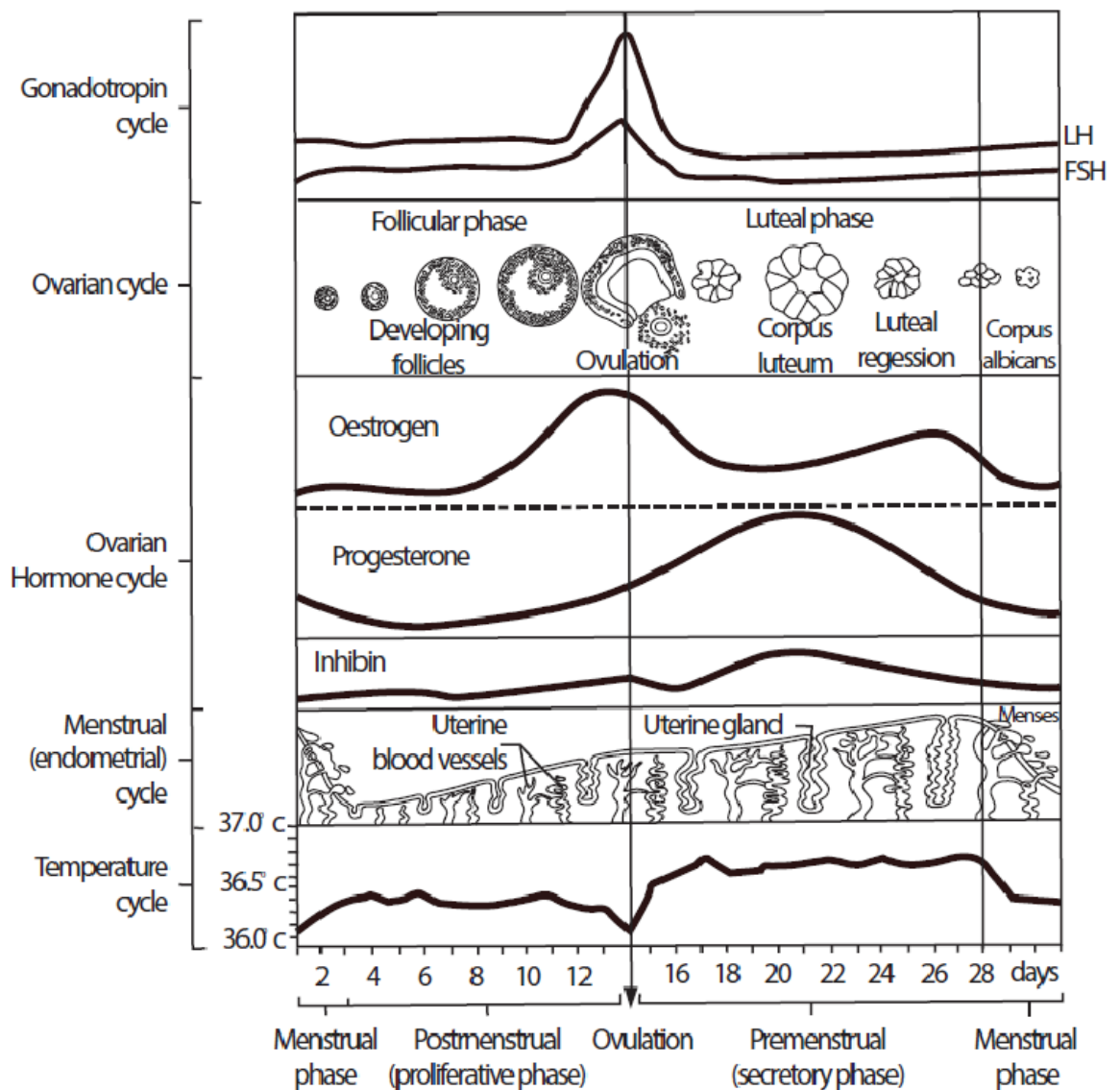

Figure 5: On Day 1st of the menstrual cycle, oestrogen and progesterone levels are low. Low levels of oestrogen and progesterone signal the pituitary gland to produce Follicle Stimulating Hormone (FSH). FSH begins the process of maturing a follicle. The follicle produces more oestrogen to prepare the uterus for pregnancy. At ovulation, usually around Day 12 – 14, increased oestrogen levels trigger a sharp rise in Luteinizing Hormone (LH) from the pituitary gland, causing the release of the egg from the follicle. The ruptured follicle (corpus luteum) now secretes progesterone and oestrogen to continue to prepare the uterus for pregnancy. If the egg is not fertilized, oestrogen and progesterone levels drop and, on Day 28, the menses begin (Shoupe and Kjos, 2006).

A regular menstrual cycle lasts on average 28 days (Teixeira et al., 2012a, Melegario et al., 2006), but it varies between women. A shift in the hormonal balance is also common, altering the individual pattern influenced by a factor like stress, anxiety or tension. The hormonal concentration of female hormones variation also affects organs that might not be directly related to the reproductive system (Table 1). A cycle ranging from 28 to 32 days for the last six-months with a consistent flow between cycles is considered regular.

Table 1: Main hormones regulators of the female reproductive system and their action.

Hormone	Action	Produced location	Mood influence	Pain influence	Other influence
<i>Follicle-stimulating hormone (FSH)</i>	Stimulates follicle development and oestrogen production.	Anterior pituitary gland			
<i>Luteinizing hormone (LH)</i>	Stimulates the release of the ovum through the rupture of the mature follicle.	Anterior pituitary gland			
<i>Oestrogen</i>	Prepares the body and uterus for ovulation and pregnancy, is responsible for the body, sex organs and secondary sex characteristics development, prepares the endometrium for pregnancy, and makes cervical mucus thinner and more alkaline.	Mostly by the ovaries but also in smaller amounts by the adrenal glands and in fat tissue.	A decrease in the oestrogen level may decrease the production of serotonin , a neurotransmitter related to the mood-enhancing qualities, as well as its influence on appetite, sleep, sexual desire, and memory.	Decreases perception of pain	It increases the synthesis and function of neurotransmitters that affect sleep, mood, memory, libido, and cognitive factors, preserve bone mass, increases high-density lipoprotein, preserves the skin elasticity and hydration, dilates blood vessels, and prevents plaque formation in blood vessel walls.
<i>Progesterone</i>	Maintain the endometrium thick when pregnancy occurs, stimulates the development of lobules and alveoli in the mammary glands. Causes premenstrual water retention slightly rise in basal body temperature during luteal phase.	Corpus luteum in the ovaries. The adrenal glands, peripheral nerves, and brain cells produce lesser amounts.			Progesterone binds to certain brain receptors to exert a calming, sedating effect. It improves sleep and protects against seizures, has a diuretic effect, enhances insulin sensitivity and the function of the thyroid hormones, increases bone production, blocks plaque formation in the blood vessels and lowers the levels of triglycerides. Increases libido and contribute to the efficient use of fat as a source of energy.
<i>Testosterone</i>	Helps women maintain muscle mass and bone strength, enhances sex drive and helps with an overall sense of well-being and zest for life.	Ovaries and adrenal glands			It strengthens ligaments, builds muscle and bone, assists brain function, and is associated with assertive behaviour and a sense of well-being, influences stamina and

					restful sleep, has a protective effect against cardiovascular disease.
<i>Relaxin</i>	Relaxes the walls of the uterus preventing early contractions, in preparation for childbirth, it relaxes the ligaments in the pelvis and softens and widens the cervix and promotes rupture of the membranes surrounding the fetus.	Corpus luteum in the ovaries and placenta during pregnancy.			Regulates the mother's cardiovascular and renal systems to help them adapt to the increase in demand for oxygen and nutrients for the fetus. Decreases tissue fibrosis in the kidney, heart, lungs and liver, and promotes wound healing. Decreases blood pressure by relaxing and promoting the growth of new blood vessels, is anti-inflammatory, is involved in bone remodelling and healing of injured ligaments and skeletal muscle
<i>Dehydroepian drosterone (DHEA)</i>	DHEA can be converted into oestrogen and testosterone through fat, muscle, bone and liver.	Ovaries and adrenal gland. Smaller amounts are produced in the skin and brain			It provides protection against the effects of physical stress and inflammation, can also increase libido and sexual arousal, improves motivation, engenders a sense of well-being, decreases pain, and enhances immune system function, facilitates the rapid eye movement (REM) phase of sleep, enhances memory, and assists in maintaining normal cholesterol levels.
<i>Cortisol</i>		Adrenal glands			It regulates the immune response, stimulates the production of glucose, aids short-term memory, and helps the body adapt to stress by increasing heart rate, respiration, and blood pressure.
<i>Pregnenalone</i>		Adrenal glands, smaller amounts in the liver, brain, skin, gonads, and even the retina of the eye.			DHEA converts to testosterone and estrogens. Additionally, progesterone converts to estrogens, cortisol, and aldosterone.

Receptors for both oestrogen and progesterone are found in connective tissues and skeletal muscle, which may explain different MTU characteristics across MCP. If the presence of increased levels of oestrogen (decreasing S_{MTU}) and/or progesterone (increasing S_{MTU}) were associated with altered stiffness of ligamentous tissues, this change would impact muscle shortening velocity, degree and muscle fascicle pennation angle (at rest and during contraction), ultimately affecting force-production capacity. During the stretch-shortening cycle (SSC) a stiffer MTU modulates the force transmission from the tendon to the bone and reduces the interval between eccentric and concentric phases (Ochala et al., 2007b). However, a less stiff MTU would lend itself to greater tendon deformation for equivalent applied forces (Onambélé et al., 2007b), reaching a greater ROM. In addition, S_{MTU} is known to be connected to the central nervous system. It is thus suggested that the sensation of pain during the stretches, controlled by mechanoreceptors, is influenced by S_{MTU} .

The endocrine process for ovulation starts with the hypothalamus activating the pituitary gland to secrete the follicle-stimulating hormone (FSH), that stimulates the ovaries to increase in size and to develop one dominant ovum. This dominant ovum is responsible for the release of a large quantity of oestrogen, which inhibits the FSH, stimulates the luteinising hormone (LH), thins the cervical mucus and make the uterine walls thicker for the implantation of a fertilized embryo (maturation of the endometrial surface) (Frankovich and Lebrun, 2000, Hennefer and Laeson, 2009). The LH is produced by the pituitary gland and acts on the ovary to release the dominant and developed ovum (Hennefer and Laeson, 2009). After this release (also known as ovulation), the blood level of oestrogen falls to approximately 50% of the peak level. In addition to this, the ovary will then produce large quantities of progesterone (Hennefer and Laeson, 2009, Frankovich and Lebrun, 2000). Progesterone increases the nutrition to the uterus and relaxes the muscle walls to accept an embryo. When fertilization occurs the levels of oestrogen and progesterone remain intact, preparing for the embedding of the developed embryo. When fertilization does not occur, the level of progesterone drops stopping this nutrition and causing the disintegrating and shedding of the walls, known as menstrual flow (Hennefer and Laeson, 2009, Frankovich and Lebrun, 2000). If both levels of oestrogen and progesterone fall, the hypothalamus detects this, and the cycle begins again.

Multiple actions on body systems might be affected by the female sex steroid hormones; such as in the strength level (Phillips et al., 1996, Onambele et al., 2006a), metabolic, thermoregulatory, cardiovascular, systemic, respiratory parameters (Frankovich and Lebrun, 2000), joint stability (Shultz et al., 2006, Shultz et al., 2004b, Park et al., 2009b), S_{MTU} , proprioception (Friden et al., 2003), muscle activation patterns (Dedrick et al., 2008), and training responses (Onambele et al., 2006a). Hormone receptors transcripts were found in the connective tissue from women (Liu et al., 1996, Sciore et al., 1998). Oestrogen affects the collagenous tissue decreasing the collagen synthesis and increasing the tissue degradation (Neugarten et al., 2000). This degradation is highlighted through decreased total collagen and protein content, fibre diameter, and density (Abubaker et al., 1996), increase elastic content (Shikata et al., 1979) and lower tensile strength (Slauterbeck et al., 1999).

Modifications in joint laxity, S_{Ten} (Onambélé et al., 2007b), muscle strength, proprioception and muscle activation patterns, were found aligned with the variation in the levels of female hormones. Greater amounts of estradiol- β -17 and progesterone would adversely affect the ligamentous laxity (Deie et al., 2002), S_{Mus} (Eiling et al., 2007) and these factors might modify the biomechanical profiles at ovulation (Bell et al., 2014b). However, other studies found no difference in similar variables (Burgess et al., 2010, Teixeira et al., 2012a), showing the lack of consensus in the literature; either way, the research is sparse and involves small numbers of participants.

Another important hormone to be considered is the relaxin, which is also an important tendon laxity modulator (Smith et al., 2014). Relaxin is a hormone produced by the ovaries and the placenta with important effects in the female reproductive system and during pregnancy (Goldsmith and Weiss, 2009). It prepares the lining of the uterus for pregnancy and in preparation for childbirth, it relaxes the ligaments in the pelvis and softens and widens the cervix (Aldabe et al., 2012). In early pregnancy, it also inhibits contractions in the wall of the uterus to prevent premature childbirth (Negishi et al., 2005). Relaxin levels rise after ovulation, during the second half of the menstrual cycle and drop if pregnancy does not occur. The production by the ovary during the menstrual cycle is stimulated by the luteinising hormone from the pituitary gland. Its release during pregnancy is also stimulated

by human chorionic gonadotrophin from the placenta. During the first trimester of pregnancy, levels rise and additional relaxin is produced by the decidua. In addition, this hormone affects other organs and systems by activating specific receptors on these tissues. Related to the muscle, relaxin therapy was shown to enhanced muscle regeneration, reduced fibrosis, and improved injured muscle strength in vivo (Negishi et al., 2005). The increase of relaxin hormone has been shown coincide with a subsequent 40% decrease in the rate of collagen synthesis (Voskanian, 2013). One hypothesis is that relaxin can drastically diminish collagen tension (Wojtys et al., 1998).

The circulating hormonal levels of oestrogen and/or progesterone could affect S_{MTU} (Uldbjerg and Ulmsten, 1990). Increased joint laxity (less stiff muscle) is exacerbated at ovulation (Onambélé et al., 2007b). Reduced S_{MTU} (more compliant MTU) would permit greater tendon deformation for equivalent forces applied (Onambélé et al., 2007b, Onambele et al., 2006b), corroborating this assumption, greater joint laxity was found in populations with a greater level of ACL injuries (Kramer et al., 2007). This greater laxity during the ovulation phase may affect dynamic joint function due to corresponding decreases in either the pre-activation of muscles to prepare the join for the application of external forces (Bell and Jacobs, 1986) and control of joint position in space (Shultz et al., 2004a). Endogenous or exogenous oestrogen might affect the injury risks by modifying the structural composition of ligaments and tendons, therefore, changing the mechanical properties (Hansen et al., 2013). A lower tendon collagen synthesis rate and overall lower tendon collagen turnover may enhance the possibility for introducing intra- and intermolecular collagen cross-links and thereby increase S_{Ten} and resistance against ruptures (Hansen et al., 2013).

A lower normalized S_{Ten} was found in ovariectomized women following oestrogen replacement therapy compared with postmenopausal peers, and this study indicated that oestrogen may enhance collagen turnover (Hansen et al., 2009a). Similarly, the lack of difference in S_{Ten} between post-menopausal women and age-matched older makes would tend to support the role of decreased oestrogen levels to relatively higher S_{Ten} (Burgess et al., 2009). Park et al. (2009b) tested the hypothesis that the knee laxity increases from the follicular phase to the ovulation due to the effect of high oestradiol on the ligament during

ovulation and decreases from ovulation to the luteal phase because of high progesterone levels. They found, on average, greater knee laxity during ovulation compared to luteal phase, however, this was not true for all subjects. Likewise, a greater joint laxity has been observed during the ovulation phase of the menstrual cycle (Heitz et al., 1999, Park et al., 2009b, Shultz et al., 2004b), although there are contradictory result as well (Pollard et al., 2006, Burgess et al., 2010). The heterogeneous response found in Park et al. (2009b) study suggests that unknown lifestyle and/or genetic factors that control tissue response to hormones may exist. Individual body composition (Janz et al., 2000), consistency of the menstrual cycle (Van Hooff et al., 1998), genetic factor such as hypermobility (Decoster et al., 1999), caloric intake (Bäumli, 1989), and habitual activity levels (Pollard et al., 2006) are all factor that may influence a subjects' knee laxity response (Park et al., 2009b).

The oestrogen was suggested to cause a disproportionate tendon joint laxity (Zazulak et al., 2006). Studies analysing one complete menstrual cycle found an increase in the ACL injury level in the pre-ovulatory phase (Hewett et al., 2007), in the early follicular phase (Slauterbeck et al., 2002), or around ovulation (Wojtys et al., 1998, Wojtys et al., 2002). (Zazulak et al., 2006) found greater knee laxity in the days 10—14 when compared to the days 15-28 of the menstrual cycle. The days 1-9 exhibited the highest values of knee stiffness.

1.1.1.2 Oral Contraceptives

Oral contraception (OC) has been used to avoid unplanned pregnancies (Abasiattai et al., 2011). A second indication consists of the treatment of some conditions such as osteoporosis, hirsutisms, endometriosis and acne (Vitzthum and Ringheim, 2005). The contraceptive pills can be divided into two types; combined hormones contraception (a combination of synthetic oestrogen in the form of ethinylestradiol and synthetic progesterone called progestogen) and progesterone-only (progestogen) contraceptive devices. The synthetic oestrogen inhibits the release of the FSH from the pituitary gland and the progestogen inhibit the release of LH (Hennefer and Laeson, 2009). In both cases, the use of hormone contraceptive inhibits ovulation (Teixeira et al., 2012a).

The use of OC suppress the endogenous secretion of female hormones and thereby the natural hormonalisation (Hansen et al., 2013). The use of OC has been associated with a greater risk of Achilles tendinopathy, persistent pelvic pain, pelvic joint instability (Saugstad, 1991) and lower back pain (Liu et al., 1996, Wreje et al., 1997). Other studies did not find any difference in lower back pain (Brynhildsen et al., 1997, Symmons et al., 1991) and risk of ACL injuries when compared with non-users of contraceptives, and a study has, in fact, reported a lower risk of traumatic injuries (Möller-Nielsen and Hammar, 1989). Oestrogen receptors have been identified in the human ACL (Sciore et al., 1998, Faryniarz et al., 2006, Liu et al., 1996), and women who are chronically exposed to oestrogen levels greater than normal follicular phase amounts of oestrogen, may have altered collagen content of tendon and ligaments (Hansen et al., 2009b) which may change the biomechanical properties (Hansen et al., 2013).

1.1.1.3 Sex Differences

Sex differences in the number of ACL injuries have been investigated (Onambélé et al., 2007b). Onambélé et al. (2007b) suggested that the composition of the tendon might be different; being the crosslinking density or arrangement of these tendons distinct between the sexes, or the ratio of type I to type III collagen is different. In addition, the total of water in the composition of the tendons may be different thereby influencing the intrinsic, structural and mechanical properties. The greater knee laxity in females demonstrate greater electromyography peak amplitude during landing from a jump, a longer time to detect joint motion in proprioception tests (Rozzi et al., 1999), and delayed generation of muscle torque in isokinetic dynamometer tests when compared to similarly aged male participants (Huston and Wojtys, 1996). Thus, there is speculation that a decreased protective mechanism caused by the increased knee laxity of females may increase the ACL injury risk during physical activity (Shultz et al., 2004a). However, contributions of variations in passive knee joint laxity during the menstrual cycle to dynamic knee joint function have not been investigated (Park et al., 2009b).

1.1.1.4 Stretching

To improve flexibility, stretch exercises should be performed (Taylor et al., 1997, Decoster et al., 2005). Flexibility improvement, however, may include either an increase in ROM_{Max}

and/or a decrease in S_{MTU} . Participants presenting higher MTU extensibility (i.e. stretch capacity), also known as compliance, were shown to improve flexibility faster when compared to stiffer participants. Additionally, different stretch techniques were found to be more efficient for determinate aim than others; an example is the efficiency of constant torque (CT) compared to constant angle (CA) to decrease S_{MTU} (Cabido et al., 2014, Herda et al., 2011a) due to greater modifications in the MTU viscoelastic properties (Herda et al., 2014). Extensibility and S_{MTU} are different despite having similar roots, as they are opposite to one another. The mechanical definition of S_{MTU} (Equation 4) suggests that the denominator provides an indication of the extensibility, defined as the available ROM at a joint (Blackburn et al., 2004).

$$S_{MTU} = \frac{\Delta torque}{\Delta ROM}$$

Equation 4: S_{MTU} = stiffness, Δ = variation.

S_{MTU} measurements may be affected by changes in angular acceleration due to variability in the soft tissue viscoelastic response and in angular inertia. Blackburn et al. (2004) established a relationship between passive moment and angular position performing linear regressions for each trial to determine this relationship. They suggested the low constant angular velocity of $5^\circ/s$ to assess the passive S_{MTU} .

Different techniques have been applied, such as dynamic (with movement) or static (without movement); passive (external forces are applied to move and stretch the limb) or active (the limb movement is done by the antagonist muscle to the one being stretched) (Table 2), and the neuromuscular proprioceptive facilitation, in which neural mechanisms are used to improve the gain in the ROM (Nelson and Bandy, 2005, Karloh et al., 2010, Di Alencar and Matias, 2010).

Table 2: Stretch techniques

	Dynamics	Static
Passive	An external force is applied (e.g. assistant or equipment) to stretch the limb up to the ROM_{Max} moving forward and backward at a rate of approximately 1 bout every second. There is no holding phase.	An external force is applied (e.g. assistant or equipment) to stretch the limb. The ROM_{Max} established is reached and maintained for a period (static phase). e.g.: Participants' limb is attached to the equipment lever that stretches the limb

	e.g.: The assistant performs the movement (Bradley et al., 2007).	(Cabido et al., 2014, Peixoto et al., 2015, Pessali-Marques, 2015).
Active	The antagonist exerts the stretching force to stretch the agonists, (Davis et al., 2005) up to the ROM _{Max} moving forward and backward at a rate of approximately 1 bout every second. There is no holding phase. e.g.: <i>Grand Battement</i> ³	The antagonist exerts the stretching force to stretch the agonists, (Davis et al., 2005). The ROM _{Max} established is reached and maintained for a period (static phase). e.g.: <i>Degagé</i>

Recently, the passive static technique has been divided in CA (when the angle is maintained constant for a period) or CT (when the torque is maintained constant by a period, even if the ROM is consequently increased) (Herda et al., 2014, Herda et al., 2011a). Herda et al. (2014) suggested that the CT allows quick changes to the passive properties of the MTU compared to CA. The CA may only affect the viscosity of the MTU, while the CT may affect both the viscous and the elastic properties of the MTU (Gajdosik, 2001). Even so, more research is needed in this area.

Cabido et al. (2014) performed 4 stretches of 30-second at 95% of ROM_{Max}, each with a 15-second interval between them, and found greater changes in the ROM_{Max}, S_{MTU}, and first sensation of tightness (FST_{ROM}) in the CT when compared to the CA. On the other hand, Herda et al. (2014) found an increase in the ROM and a decrease in passive resistance torque using both CT and CA techniques after 16 stretches of 30 seconds at the point of discomfort but not pain, with a 20-second rest between them. However, a decrease in the S_{MTU} was only noticed after the CT. The authors also suggested that the type of “static” stretching is an important factor to be considered if the effects of stretching on the passive properties of the MTU are being examined.

Taylor et al. (1990) executed a series of experiments using rabbit hind limb where ten repeated stretches to the same load were performed in the first protocol segment and 10 series of 30 seconds of passive static stretching in the second protocol segment. They found no peak tension difference after the first four bouts and no stress relaxation after the first four series of passive stretching. Similarly, *in vivo* studies concerned with human MTU response to stretch were performed (Bandy and Irion, 1994, Bandy et al., 1997, Odunaiya et

³ For a detailed explanation and illustration of steps (e.g. *grand battements and développés*) see Appendix B page 268.

al., 2005, Ryan et al., 2008b, Opplert et al., 2016). There is, however, no consensus in the literature regarding the most efficient stretching protocol. The main reason may be due to different methods, and as such, current data does not allow the comparisons between studies (Table 2).

Research on stretching protocols in dancers also shows a lack of consensus (Wyon et al., 2009, Smith et al., 2013, Lima et al., 2016, Rubini et al., 2011). Wyon et al. (2009) compared different intensities of stretching and concluded that low-intensities were more beneficial to the active and passive ROM increase. They suggested that an adaptation occurred within the muscle structure by depressing the response of the sympathetic nervous system and dampening the Muscle Spindles and Golgi Tendon Organ due to the low intensity and the participant positioning during the stretches. These findings contradicted previous results showing a greater increase in the ROM for greater intensities (Chagas et al., 2008, Freitas et al., 2015).

Although previous research suggested that a reduced parasympathetic activity would be caused by the utilization of lower intensity stretching exercises, thus permitting adaptation to happen within the muscle itself offering less resistance when it is being elongated by the contraction of its antagonist muscle (Wyon et al., 2013, Wyon et al., 2009), only the ROM was measured. Therefore, any modification in the S_{MTU} perceived in high-intensity stretches (Cabido et al., 2014, Herda et al., 2014, Freitas et al., 2015) would not have been noticed or reached.

Apostolopoulos et al. (2015b) analysed the inflammatory response after 5 x 60-seconds passive static stretching in three different intensities: 30, 60 and 90% of the ROM_{Max} . They used the C-reactive protein (hsCRP) as inflammation marker and found a significant difference when 30 and 60% were compared to 90%, suggesting that intensities greater than 60% of the ROM_{Max} should be avoided. However, they did not measure the ROM improvement after the stretching, this way; it is not possible to know if such small intensities would have resulted in an improvement. In addition, previous studies did not find accommodation after 30-seconds stretching (Bandy and Irion, 1994, Bandy et al., 1997);

suggesting that the 60-seconds performed may have influenced the inflammatory responses.

Freitas et al. (2015) compared combinations of intensity and duration analysing the length-tension curve modification after an acute session of stretch. They found that higher intensity stretches potentiate the ROM increase, while submaximal intensities, however for a longer period under stretch, potentiate the passive torque decrease. Similar studies but analysing either the response after chronic training or in different portions of the length-tension curve are needed to assure what are the adaptations to a mechanical stimulus after different training protocols.

In addition, regarding training frequency, when only one stretching session is performed, it is characterised as acute training, while more than one session would indicate a chronic training (Peixoto et al., 2015). Modification in the ROM_{Max} was found in result to either acute (Cabido et al., 2014, Herda et al., 2011a, Yeh et al., 2005, Yeh et al., 2007), or chronic training (Peixoto et al., 2015). The alteration of different variables beyond the ROM_{Max}, and the magnitude of each variables' modification, however, highlight the contrast between acute and chronic training.

Recently, Pessali-Marques (2015) compared the MTU response to acute passive static stretching with CT, among dancers and non-dancers. ROM_{Max}, first sensation of stretch (FSS) and ROM_{torque} (ROM for a comparable torque pre- and post-intervention) were measured. The FSS is used to evaluate modifications in stretch tolerance and was indicated when participants perceived the beginning of tension in the hamstrings. The exact point was then marked in the ROM and torque curves. Therefore, FSS had subcomponents including FSS_{ROM} and FSS_{torque}. The author found a greater increase in the ROM_{Max} for the dancers, but no difference in the ROM_{torque} between the groups. This indicates that viscoelastic modifications occurred in both groups, but the modification in the stretch tolerance may have played a role in the greater increase for the dancers. The FSS_{ROM} and FSS_{torque} showed that dancers responded differently to non-dancers, however, the mechanisms for this difference still need to be explored. The power of the study was large enough (0.86 to FSS_{ROM} and 0.7 to FSS_{torque}), with effect size (0.18 to FSS_{ROM} and 0.14 to FSS_{torque}) and $\alpha=0.05$

reinforcing the consistency of this result. Therefore, the investigation of pain in a multidisciplinary approach (physiologically, psychologically and biomechanical) may help to expose the mechanisms behind this reported difference in stretch tolerance, between dancers and non-dancers.

1.1.1.5 Strength and Cross-Sectional Area

Strength can be defined as the maximal force or torque developed by a muscle aiming to perform a specific joint movement (Komi, 1992). The potential for force generation, indicated by the increase in the strength is typically manifested by an increase in the cross-sectional area (CSA) due to a net accretion in muscle protein. Therefore, a loss in the muscle tissue possibly diminishes the force-generating capabilities of the muscle (Crewther et al., 2006). The CSA is measured in a plane axial to the longitudinal axis of the muscle (Abe et al., 2017).

Differences in CSA can affect S_{MTU} values due to a mathematical property concerned with an area and how that area is distributed about the reference axis. The Area Moment of Inertia describes the capacity of a cross-section resisting to bend; the higher the area, the higher the S_{MTU} . Therefore, it is important to normalise the S_{MTU} to account for these dimensional factors when comparing groups. Magnetic resonance imaging (MRI) is the gold standard to measure CSA (Magnusson et al., 1997), however, ultrasound is also highly used (Kanehisa et al., 1994) and considered reliable and cheaper to evaluate the CSA (Franchi et al., 2017, Abe et al., 2017). In addition, the ultrasound was highly correlated with the MRI (Miyatani et al., 2001) and has the same advantages of the MRI and computerized axial tomography (CT) in making visible fat and muscle tissues assessment without compression and radiation exposure. The ultrasonography is useful in estimating the muscle volume (Miyatani et al., 2001) as the MRI, but it is more suitable for field use and serial evaluation (Ishida et al., 1995). Finally, the ultrasound provides the physiological CSA; that is the cross-section of all fibres at a right angle (usually assessed in the site of bigger circumference when the force is to be normalized to CSA) while the MRI provides the anatomical CSA. A greater variability was found to be related to an incorrect normalization of the force per the anatomical CSA instead of using the physiological CSA. It is a common understanding that there is a direct proportionality between the force and its CSA, thus, if the force is normalized to the

physiological CSA not great variations among muscles and populations would be expected (Narici, 1999) and it is more linearly associated with muscle strength.

The muscle thickness obtained using the ultrasound, although related to the increase in CSA, was associated with each muscle's hypertrophy from resistance training and should not be used to predict changes in the volume of the thigh (Franchi et al., 2017). Contradicting this results, for the forearm muscle CSA in young adults, the thickness was found to be useful for the same aim (Abe et al., 2017).

A study comparing the structural components of tendons in women and men showed a lower rate of new connective tissue formation, a lower response to mechanical loading, and a lower mechanical strength in women, which may offer less protection to injury (Magnusson et al., 2007). When the CSA was compared, women showed larger fat CSA and smaller bone and muscle CSA than men in the thighs. When strength was expressed per unit of muscle (F/CSA), however, no sex difference was found (Kanehisa et al., 1994). A decrease in isometric strength in elderly men was found when compared to young men. This difference was accounted for by their decrease in muscle CSA (Overend et al., 1992).

Resistance training was found to be effective to increase the strength (Lopes et al., 2017), S_{MTU} (Albracht and Arampatzis, 2013) and muscle CSA increase (Franchi et al., 2017). In addition, S_{MTU} and strength were found to play a role in many movements, such as flexibility (Magnusson et al., 1997), the second phase of 100m sprint (Bret et al., 2002), the economy of force generation by the *triceps surae* in the running (Albracht and Arampatzis, 2013), the set of stride frequency for running (Farley et al., 1991), the long jumping distance (Seyfarth et al., 2000), and the increased efficiency of the stretch-shortening cycle (Avela and Komi, 1998a).

A study with dancers found a significant influence of the thigh and calf girth circumferences on maximal jump height (Wyon et al., 2006). Despite resistance or weight lift training being recognised as important stimuli for strength and power increase (Crewther et al., 2006), dancers seems to not undertake sufficient resistance training due to the reluctance to sustaining increased muscle mass, as this tends to not be a desired trait (Wyon et al., 2006).

On the other hand, the use of plyometric training as an intervention strategy to increase jump height showed no significant changes in the gastrocnemii S_{Ten} , or in the muscle CSA (Fouré et al., 2012), demonstrating to be a potential-jump training for dancers. The changes found in the plyometric training were mostly in neuromuscular aspects of power instead of in the muscle volume (Wyon et al., 2006).

1.1.1.6 Changes in the intramuscular structure and/or composition

The passive S_{MTU} is the resistance to elongation that does not require metabolic energy. The resistance when the muscle is stretched is due to three main structural elements: the connective tissues (within and around the muscle), the stable cross-links (between actin and myosin filaments), and the non-contractile proteins (mainly titin) (Latash and Zatsiorsky, 2015). The level of overall muscle compliance can also be influenced by the contractile elements when activated, and hence, compliance can be modified to suit different tasks (Witvrouw et al., 2004).

The MTU contractile components are responsible for force generation, length-tension and force-velocity relationships, whereas the muscle's length, velocity during contraction, and activation level will affect the contractile elements. The number of cross-bridges formed in parallel is the primary determinant of active S_{MTU} (Morgan, 1977). The increase of electromyography (EMG) activity provided by muscle contraction or the spinal reflex, are associated with an increased number of cross-bridges set in parallel, therefore, increasing the active S_{MTU} . Although the elastic elements, PEC and SEC, represent mainly the properties of the connective tissues and therefore, the passive S_{MTU} , the titin, present in the cross-bridges is activation dependent (Latash and Zatsiorsky, 2015).

The muscle fibres are made from a material with high tensile strength and embedded in another material (called matrix), which glues the fibres together and transfers external stresses (Latash and Zatsiorsky, 2015). After stretching, the mobile components within the tissues, that is, the liquid and polysaccharides may be redistributed within the collagen matrixes (McNair et al., 2001). After a periodic stretching programme, structural changes to collagen are more likely (Witvrouw et al., 2004).

1.1.1.7 Warm-up and temperature

The warm-up is a preparatory exercise for improving performance (Fradkin et al., 2006) aiming to increase the internal muscle temperature thus, decreasing muscle and joints S_{MTU} . This internal muscle temperature increase also works towards enhancing nerve conduction velocity (better proprioceptors sensitivity, coordination and recruitment of motor units), enzyme activity, (increase glycogenolysis, glycolysis and high-energy phosphate degradation) and oxygen diffusion, changing the force-velocity and length-tension relationships (Morrin and Redding, 2013, Stewart et al., 2003, Edwards et al., 1972, Bishop, 2003, de Albuquerque et al., 2011).

The increased muscle temperature may affect the physical and mechanical properties of collagen (Magee et al., 2007) changing the tissue elasticity. The decrease in the gamma fibre activity and muscle spindle sensitivity, with a consequent increase in the activation of the Golgi tendon organs, contribute to muscle relaxation (Di Alencar and Matias, 2010, Maciel and Câmara, 2008). In rapid movements, such as *grand jetés*, relaxation is fundamental in preventing injury of the antagonistic muscles (Grego et al., 1999).

The active warm-up may affect S_{MTU} by “breaking” the stable bonds between actin and myosin filaments (Behm et al., 2004), therefore, flexibility could be improved once a greater ROM may be reached for the same applied torque, or the same ROM can be attained with a smaller torque. O'Sullivan et al. (2009b) found a significant increase in flexibility after an aerobic warm-up. Supporting this study De Weijer et al. (2003) found significant ROM increase coupling warm-up and passive stretch. The warm-up alone tended to increase flexibility though not significantly so. Approximately three to five-minutes warm-up of moderate-intensity is likely to improve performance in a range of tasks. It is important that the warm-up intensity is programmed according to individual capacity to promote temperature increase and avoid fatigue; also, the intensity might change according to external factors, such as weather (Bishop, 2003) or clothing (Pessali-Marques et al., 2012).

Warm-up techniques can be done through the influence of the environment, therapeutic resources or muscle contraction. The latter is usually classified into two categories: passive warm-up (external means to increase internal or muscle temperature) or active warm-up

(exercises) (Bishop, 2003). According to Hall (1995), the muscle function is more efficient at 38.5°C and profound changes in tissue properties occur at therapeutic temperatures between 40°C and 45°C. A study by Bertolini et al. (2009) stated that the use of thermal ultrasound increased muscle extensibility. Silva et al. (2010) related this increase to a decrease of viscosity, tissue tension and to the relaxation of the mechanical properties of the muscle (decrease in the S_{MTU}).

Tissue heating has been suggested to increase metabolism and reduce mild inflammation due to a rise of 1 °C in the temperature. An increase in blood flow and a reduction of muscle spasm and pain were found as a result of a 2- 3 °C rise, and increases in ROM and tissue extensibility resulting from a rise of 4 °C (Knight and Draper, 2012).

The ultrasound is capable of producing an increase in the local temperature of more than 3°C, which would induce viscoelastic changes in the collagen (Hall, 1995). In a study where the local muscle temperature was increased approximately 4°C at a depth of 3-5 cm for 5-minutes, the result showed increased collagen fibres extensibility increase and changes in the viscoelastic and mechanical properties of the muscular tissue, and therefore, increased flexibility (Silva et al., 2010). In addition to the increase in the ROM, increase in the stretch pain tolerance was also reported (Morishita et al., 2014). Thermotherapy modalities, when applied before therapeutic exercises, were found to improve connective tissue (such as collagen fibre) extensibility thought the enhancement of the stretching effect. Transcutaneous electrical nerve stimulation (TENS) has previously been applied to relieve pain before the application of ROM exercises in the clinical setting when the pain was the primary complaint (Karasuno et al., 2016).

1.2 The interaction between S_{MTU} , ROM and jump height capabilities

A muscle-tendon unit (MTU) variable called S_{MTU} influences ROM and jumping height capacities. S_{MTU} is associated with resistance to elongation as well as the capacity of absorbing elastic potential energy by the stretch-shortening cycle (SSC), which is present in countermovement jumps (Witvrouw et al., 2004, Svantesson et al., 1998) and especially those jumps with decreased ground contact time (Wilson and Flanagan, 2008). S_{MTU} during

stretching has also been investigated in recent studies (Cabido et al., 2014, Blazevich et al., 2012, Marshall et al., 2011).

Researches focusing on flexibility and strength have shown a decrease in the jump height after flexibility training protocols (Herda et al., 2008, Morrin and Redding, 2013). One possible explanation is the decrease in passive S_{MTU} (Costa et al., 2010), which is associated with the ability of the tendon to transfer forces rapidly and effectively (Onambélé et al., 2007b, Witvrouw et al., 2004). This way, a stiffer tendon is able to transfer the muscle forces to the bone more rapidly than a less stiff (Onambélé et al., 2007b), on account of more work directly converted into external work (Witvrouw et al., 2004). Wilson et al. (1994) concluded that less stiff muscles generated less power due to the delayed transfer of energy through the MTU. The same author, however, observed in another study that increasing the compliance of the MTU through stretching, increased the contribution of potential elastic energy to the movement, facilitating performance in as SSC movement (Wilson et al., 1992). In addition, to improve flexibility, passively stiffer participants were found to be less flexible, requiring more force to reach the same ROM and having a lesser stress relaxation response than the passively compliant peers (Blazevich et al., 2012).

Using a spring as an analogy, in one hand, when a passively stiffer muscle is elongated, a greater amount of potential energy is stored in the elastic components. Therefore, the amount of energy would enable a higher jump using fast SSC. On the other hand, to raise a limb, the agonist muscles should be able to be the main contributors to the forces to enable movement. Similarly, the passive resistance offered by the antagonist muscles, the gravitational pull (when the movement is opposite to the gravity) through the weight of the limb should be lower than the maximal agonistic muscle effort. A passively stiffer muscle would offer more resistance to the movement, increasing the difficulty of those movements.

Different combinations of length increase and modifications in the whole muscle-tendon unit under stretch may happen, once the fascicle lengthening is not uniform. The sarcomeres in the muscle belly stretch first and mostly, therefore the MTU components may change at a different speed or even change in the opposite direction to each other (Cronin et al., 2013). Elastic bodies, when stretched, accumulate potential elastic energy. The

amount of energy is proportional to the force and amount of deformation. Therefore, when subjected to the same force, more compliant (less stiff) bodies, will present greater displacement, thus accumulating more energy (potential energy= $\frac{1}{2}k.x^2$). The magnitude of the deformation of the MTU length-tension curve is affected by its S_{MTU} (Witvrouw et al., 2004, Onambele-Pearson and Pearson, 2007, Pearson and Onambele, 2005), which hinder the expected results for a linear spring behaviour and provides dissemblance among studies that tried to use disparate ways of quantifying the slopes of this relationship and hence the S_{MTU} (Pearson and Onambélé, 2012).

Through acute training protocol, it is possible to modify the S_{MTU} or other flexibility variables, such as the ROM_{Max} , remaining the S_{MTU} intact. Studies concerning flexibility found an increase in ROM_{Max} without changes in S_{MTU} (Magnusson et al., 1996b, Ylinen et al., 2009, Magnusson and Renström, 2006). Others affirm that through constant torque stretching it was possible to increase ROM_{Max} and decrease S_{MTU} (Herda et al., 2011b, Yeh et al., 2005). If necessary, an increase in S_{MTU} may be possible by increasing the muscle cross-sectional area or through neuromuscular activation through plyometric jumps training (Wilson and Flanagan, 2008). Table 3 presents a literature review on studies that evaluated the S_{MTU} .

As dancers need to execute jumps with height and accuracy, concomitantly with the highest ROM possible (Morrin and Redding, 2013), it is necessary to study the influence of S_{MTU} on flexibility and jumps. Specifically, as the effect of the re-utilization of elastic energy on the efficiency of movement has been debated with no consensus, and it seems that different sports modalities may require different levels of S_{MTU} . Therefore, there may be an optimal level of S_{MTU} , influenced by structural characteristics of the MTU, during different tasks in sports (Witvrouw et al., 2004).

Table 3: Literature review on studies evaluating S_{MTU} ⁴

Author	Muscle	Sample size (n)	Stretch	Equipment	Duration (s)	Series	Intensity	Days p/w	Weeks	Results	Stiffness	Limitations
(Oduunaiya et al., 2005)	Hamstrings	37 males and 23 females adult	Passive Static	Goniometer	15, 30, 60, 90, 120	1	up to a "gentle stretch"	Alternate	6	No difference among the durations.	Reduced and maintained after 7 days	Besides the increase in flexibility was mentioned only the <i>tightness</i> was provided.
(Ryan et al., 2008b)	Plantar flexors	12 adults	Passive Static	Biodex System Isokinetic	30	4, 8, 16	Discomfort	1	acute	Decreased after all stretches and returned to baseline after 10 min for the smallest intensity and after 20 min for the others	Reduced	Only measured passive stiffness. The duration is not applicable in the practice field.
(Opplert et al., 2016).	Plantar Flexors	10 men	Passive Static	Isokinetic dynamometer	30	1, 2, 3, 4 and 10	Maximum tolerated	1	acute	All the duration altered mechanical properties, but 10x30 did not affect further. Stretching does not impair spinal excitability.	Reduced	Only mechanical variables were measured.
(Kubo et al., 2002)	Plantar Flexors	8 men	Isotonic resistance training and Passive static	Isokinetic dynamometer	45	Resistance: 10 Stretching: 5	5 sets 70% MVC 35 degree	4	8	Resistance training alone or combined with stretching increased the stiffness of tendon, muscle strength and size. Stretching did affect the viscosity but not the elasticity.	Increased after resistance training and. did not decrease after stretching.	The stretching was based on the angle and not on the individual's personal intensity.

⁴ The literature search was conducted over a period from 2000 to January 2018 using the PubMed database and the following keywords: stiffness, passive stiffness, muscle-tendon unit stiffness.

Author	Muscle	Sample (n)	Stretch	Equipment	Duration (s)	Series	Intensity	Days p/w	Weeks	Results	Stiffness	Limitations
(Freitas et al., 2015)	Hamstrings	17 males	Passive static	Passive knee extension in the dynamometer shaft (Biodex System 3, Shirley, NY, USA)	90, 135, 180	5	100, 75, 50% of the maximum without pain	1	Acute	Higher intensity stretch potentiates the acute joint range of motion gains, and a submaximal intensity and higher time under stretch potentiate passive torque decrement.	Decreased in higher durations	Data analysis should be performed for different angles of the length-tension curve to assure the real adaptations to mechanical stimulus.
(Kubo et al., 2001a)	Calf	28 men adult	Passive test	Ultrasound and Isokinetic	test	-	-	1	Acute	Passive stiffness was independent of the elasticity of tendon structures and had no effect on the muscle performance in the SSC.	Negatively correlated to the relative increase in torque. Not correlated with tendon stiffness.	
(Kubo et al., 2001b)	Calf	7 men	Passive static		600	1	35 degree	1	Acute	No significant change in the MVC but significant decrease in stiffness and hysteresis. Increase in elasticity.	Decreased	The duration is not applicable in the practice.
(Mahieu et al., 2008)	Calf	64	Eccentric training	Goniometer dynamometer and ultrasound	15	3	-	7	6	Modifications to structure rather than to stretch tolerance in the ROM increased and torque decreased.	Did not change	
(Freitas et al., 2015)	Semitendinosus, vastus medialis	17 men	Passive static	Goniometer	90, 135, 150	1	50, 75% maximum without pain	4	Acute	No difference between the protocols	Did not change	

1.3 Flexibility training

The capacity of reaching a determinate ROM in a joint is called flexibility (Magnusson et al., 1997, Di Alencar and Matias, 2010), the ROM is commonly used to reflect it, therefore, an increase in the ROM_{Max} may represent an improvement in flexibility (Chagas et al., 2008, Magnusson et al., 2000). The isolated measurement of the ROM is, however, not enough to understand the MTU behaviour after stretching protocols. Due to viscoelastic behaviour, when the MTU is stretched, variables such as stress relaxation and creep may be measured. Stress relaxation is the torque decrease when the ROM is maintained constant for a period whereas creep is the ROM increase when the applied torque is maintained constant for a period (Magnusson et al., 1997, Taylor et al., 1990). The elastic component is load-dependent, while the viscosity is a rate-dependent.

Besides stress relaxation and creep, other variables may provide additional information to understand the MTU behaviour in response to interventions including torque, potential energy, hysteresis, passive S_{MTU} (Taylor et al., 1990, Magnusson et al., 1997, Mcnair et al., 2001, Cabido et al., 2014) and the first sensation of stretch (FSS). Weppler and Magnusson (2010) have suggested a multidisciplinary approach, in which, besides the ROM, these other biomechanical and sensory variables of the MTU should be considered. These variables will be discussed in the followed sessions and are the dependent variables within the current research.

1.3.1 Biomechanical variables involved in MTU response to flexibility training: definitions

The torque is the rotational force applied to the joint aiming to stretch the MTU (Weppler and Magnusson, 2010). When the applied torque and the consequent ROM are measured the Length-Tension curve may be plotted (Cabido et al., 2014, Blazeovich et al., 2012, Marshall et al., 2011) (Figure 6).

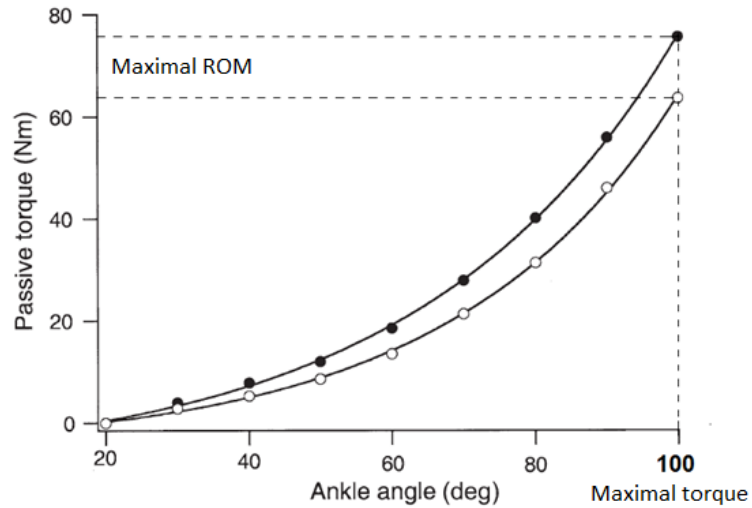

Figure 6: Length – Tension curve displacing the maximal torque and maximal ROM. Modified from Cabido et al. (2014).

The potential elastic energy is the energy stored in the elastic components of the MTU and is represented by the area under the Length-Tension curve (Silveira et al., 2011, Aquino et al., 2006). The energy may be used in subsequent movements as jumping and running. The hysteresis is the difference between the potential energy absorbed by the MTU during the stretching and the remaining energy in the MTU after the muscle be back to the initial position (Magnusson, 1998).

The stress relaxation is the torque decrease when the ROM is maintained constant for a period and the creep is the ROM increase when the applied torque is maintained constant for a period (Magnusson et al., 1997, Taylor et al., 1990) (Figure 7).

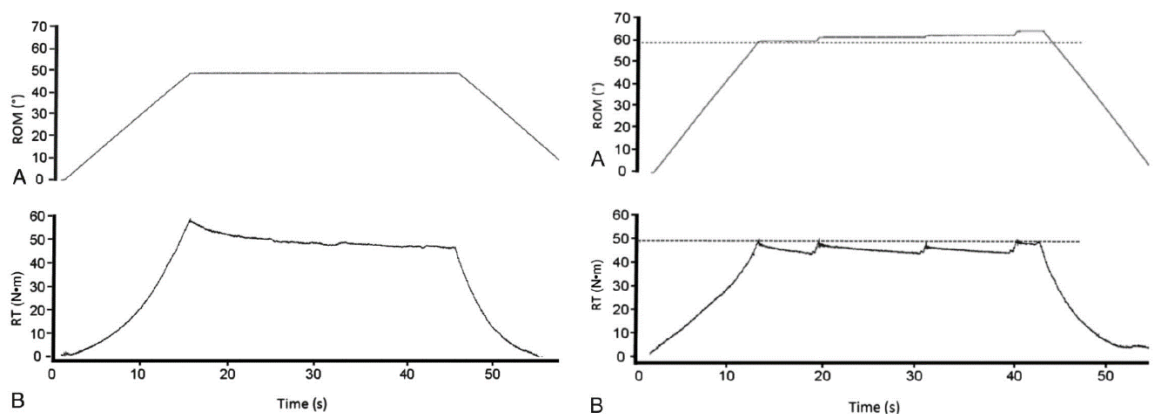

Figure 7: Stress relaxation and creep respectively. Modified from Cabido et al. (2014).

The S_{MTU} is the torque variation per the ROM variation and it has been analysed in previous studies (Kubo et al., 2001a, Blackburn et al., 2004, Magnusson et al., 1997) to understand the biomechanical behaviour of the tissue. It is represented by the slope in the Length-Tension curve (Herda et al., 2011a) (Figure 8).

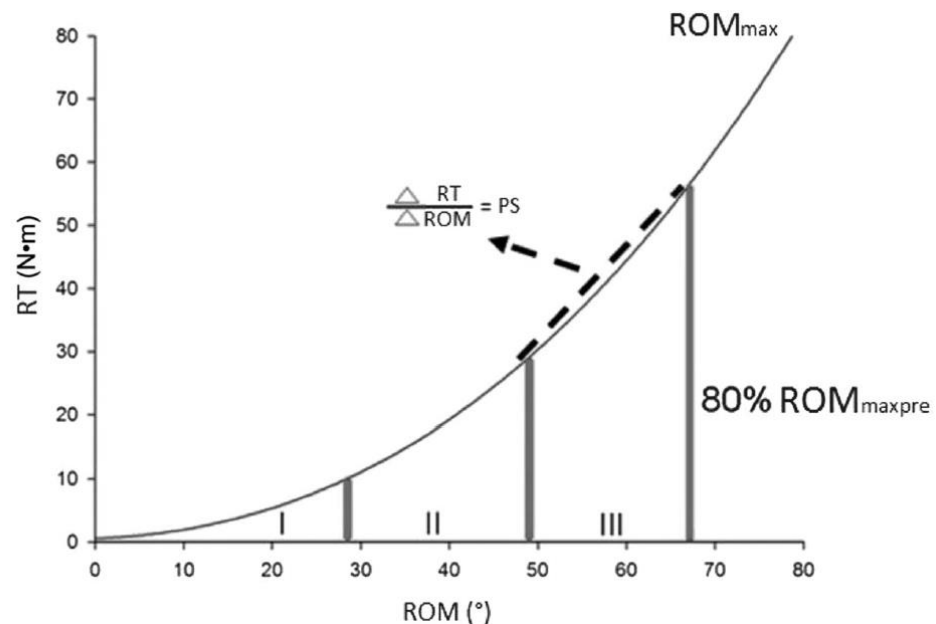

Figure 8: Length – Tension curve displaying the S_{MTU} . Modified from Cabido et al. (2014).

Changes in the viscoelastic properties of the MTU are likely to modify the S_{MTU} (such a change would be visually translated into a change of the shape of the Length-Tension curve (Herda et al., 2014) shifting this curve to the right if the S_{MTU} is decreased). However, despite the evident increase in ROM_{Max} , some authors did not find any shift of this curve (Magnusson et al., 1996b, Ylinen et al., 2009). They have justified this increase by the modification in the stretch tolerance (LaRoche and Connolly, 2006, Ylinen et al., 2009, Magnusson et al., 1996b).

1.3.2 Sensory variables involved in MTU response to flexibility training: definitions

Pain and stretch are two of many aspects of proprioception or perception of oneself (Berardi, 2016) that can respectively relate to nociception and interoception (Craig, 2003, Craig, 2009). Recent studies on the neurophysiology of interoception and nociception (Indo, 2014, Mayer et al., 2015, Labus et al., 2016) are likely to inform the relation between pain and stretch sensations (Ramel et al., 1999, Morishita et al., 2014), the accommodation processes in flexibility training, and the modification of sensory properties. Therefore,

stretch pain is defined as pain associated with stretching stimulations in soft tissues such as the skeletal muscles (Ramel et al., 1999). The control of stretch pain is necessary to increase the range of motion (Morishita et al., 2014). Due to the MTU viscoelastic response, the passive resistance to stretching is equal to the tensile force applied (torque), therefore, the relationship between the tension applied and the resultant deformation can be described by the length-tension curve (Weppeler and Magnusson, 2010). The amount of tension applied during stretch varies depending on each participant's subjective pain/sensation threshold (Weppeler and Magnusson, 2010).

Pain is a vital function of the nervous system, a sub-modality of somatic sensation intended to warn of damage, threat or danger to the tissues. It is both a sensory and emotional experience, affected by psychological factors such as experiences, beliefs about pain, fear or anxiety (Anderson and Hanrahan, 2008, Claus and MacDonald, 2017) and even personality type. There are many situations however, in which the sensory perception may not accurately reflect what is occurring in the tissues (Claus and MacDonald, 2017). Ideally, the sensory inputs (i.e. mechanical stress, chemical, heat or cold exposure) should be accurately represented after the brain's perception (Claus and MacDonald, 2017). Therefore, for the same stimulus, the same level of pain amongst people should be perceived, instead, variable levels of pain perception to the same event are reported (Coghill et al., 2003).

Further to the aforementioned topic, the main difficulty in pain assessment, whether that be in a clinical or research setting, is that pain remains a subjective experience. Indeed, the inter-individual variability can be high under similar conditions (Edwards, 2005, Gracely, 2006, Khan and Stroman, 2015) but intra-individual variability can also be high due to habituation (Slepian et al., 2017), psychological dimensions (France et al., 2002, Drahovzal et al., 2006) and contextual factors (Kamping et al., 2016).

The nociceptors are specialised sensory receptors responsible for the detection of noxious (unpleasant) stimuli. They transform the stimuli into electrical signals, which are then conducted to the central nervous system. They are nerve endings for the detection of mechanical stress, chemical, heat and cold stimuli (which in some levels may cause injuries)

and are found in abundance in the skin, joints, bones, muscles and other soft tissues (Claus and MacDonald, 2017). In skeletal muscle, the free nerve endings appear to be distributed evenly in the proximal-distal direction (Mense, 2010). The term “free nerve ending” indicates that in the light microscope no (corpuscular) receptive structure can be recognized. A receptive ending together with its afferent fibre is called an “afferent unit” (Mense, 2010).

Once detected by the nerve endings, the stimulus is transmitted to the spinal cord, the number of stimuli, however, may be distorted or amplified during the process (peripheral sensitization) (Claus and MacDonald, 2017). The spinal cord and brain may also further modify the stimuli (central sensitization) (Claus and MacDonald, 2017). Only after the brain has interpreted the stimuli signal, that the pain is considered a perception (Claus and MacDonald, 2017). The memories of danger, injury or even the anticipation of threat can be enough to induce a reverse pathway, stimulating the brain to perceive pain even without any stress in the body (Claus and MacDonald, 2017).

The sensory input from the body, thoughts, feelings, expectations and emotions may contribute to how the brain perceives pain and responds to it (Claus and MacDonald, 2017). In a qualitative study, dancers were interviewed and asked to define what they meant by pain. They had difficulty in defining pain (Anderson and Hanrahan, 2008, Thomas and Tarr, 2009) but were able to list its characteristics. Forty-three per cent of those who reported recent dance-related pain did not consider that the pain constituted an injury. They also have classified pain in two categories: "Good" pains, also called training or stretching pains, something you "do to yourself", and "bad" pains referred to as injury pains (Thomas and Tarr, 2009). Anderson and Hanrahan (2008) called “performance pain” and “injury pain” and highlighted the importance of a distinction between those to be able to alter their coping methods to appropriately manage the type of pain experienced.

The use of the phrase “dance through pain or injury”, shared among dancers is indicative of the high self-efficacy and resilience of this population (Claus and MacDonald, 2017, Anderson and Hanrahan, 2008). The pressure on the individual dancer to keep on working in spite of pain is strong, as it can be a problem for both the dancer, whose career might be

at stake and the theatre, which can be financially hurt from cancelled performances (Ramel et al., 1999).

Tajet-Foxell and Rose (1995) compared the pain tolerance between dancers and non-dancers using the *Cold Pressor Test*. They found a high general pain tolerance in dancers, suggesting that the familiarity with the stretching and the training discomforts might have influenced the general pain threshold. The authors justified these findings to their greater exposure to physical training and their increased fitness. They suggested further study of the contribution of psychological factors to understand this difference in pain perception.

Chronic pain involves many peripheral and central sensitization processes, from nerves ending to brain perception of pain. Acute pain represents a combination of tissue damage, pain, and anxiety (Claus and MacDonald, 2017). The responses to the pain perception could include stress-related changes in the hormonal system, immune system, cardiovascular system, and flight or fight responses. It is also one of the factors affecting motivation to respond and act.

Increases in the muscle length are reflected on the length-tension curve by a shift to the right of the entire curve, indicating a decrease in the S_{MTU} and an increase in the maximal ROM (Weppeler and Magnusson, 2010). The reduction in the S_{MTU} is associated with biomechanical modifications. An increase in the length can also be detected due to a further ROM attainment caused by more tension applied, in this case, no biomechanical modifications would have happened, but the results could be attributed to a sensory alteration (Weppeler and Magnusson, 2010).

Stretch tolerance has been analysed through the modification in the first sensation of stretch (FSS) (Cabido et al., 2014). The FSS is the point at which tension due to stretching is perceived in the MTU. This point is marked in the Length-Tension curve providing respective values for the torque and the ROM, being called FSS_{torque} and FSS_{ROM} , respectively. An increase in the tolerance is expected when a greater ROM, with no shift in the Length-Tension curve, is reached after either, acute (Cabido et al., 2014, Halbertsma and Göeken, 1994) or chronic intervention (Ylinen et al., 2009).

Recently, studies have found that both the biomechanical and the sensory mechanisms are involved in the ROM increase after stretching (Cabido et al., 2014). Cabido et al. (2014) compared the acute effects of the constant torque (CT) and constant angle (CA) stretching on the maximum ROM, passive S_{MTU} and the first sensation of tightness (FST) in the hamstrings. The authors have used the FST to indicate sensory modifications (if the FST was signalled in a greater ROM after stretching an increase in tolerance would have happened) and the S_{MTU} modification to indicate biomechanical modification (to reach the same ROM a smaller torque would be needed). They found both a reduction in the S_{MTU} and an increase in the FST, indicating that the biomechanical and the sensory properties were involved in the ROM increase after stretching.

The FST increase for a greater ROM after CT and CA stretching (Cabido et al., 2014, Herda et al., 2014) are supported by previously proposed notion that nociceptive nerve endings that are sensitive to mechanical stress in the muscles and joints are involved in the individual's tolerance to stretching (Magnusson et al., 1996a).

Assuming that the resistance torque resulting from the muscle deformation during the stretching is monitored by mechanoreceptors (Avela et al., 1999) the necessary torque to stimulate these mechanoreceptors could be considered a mechanical threshold for the stretch pain. The point that participants signal a tension in the stretched muscles will be called in this body of research first sensation of stretch (FSS) and its respective values for the torque and the ROM in the length-tension curve will be called FSS_{torque} and FSS_{ROM} respectively (Figure 9).

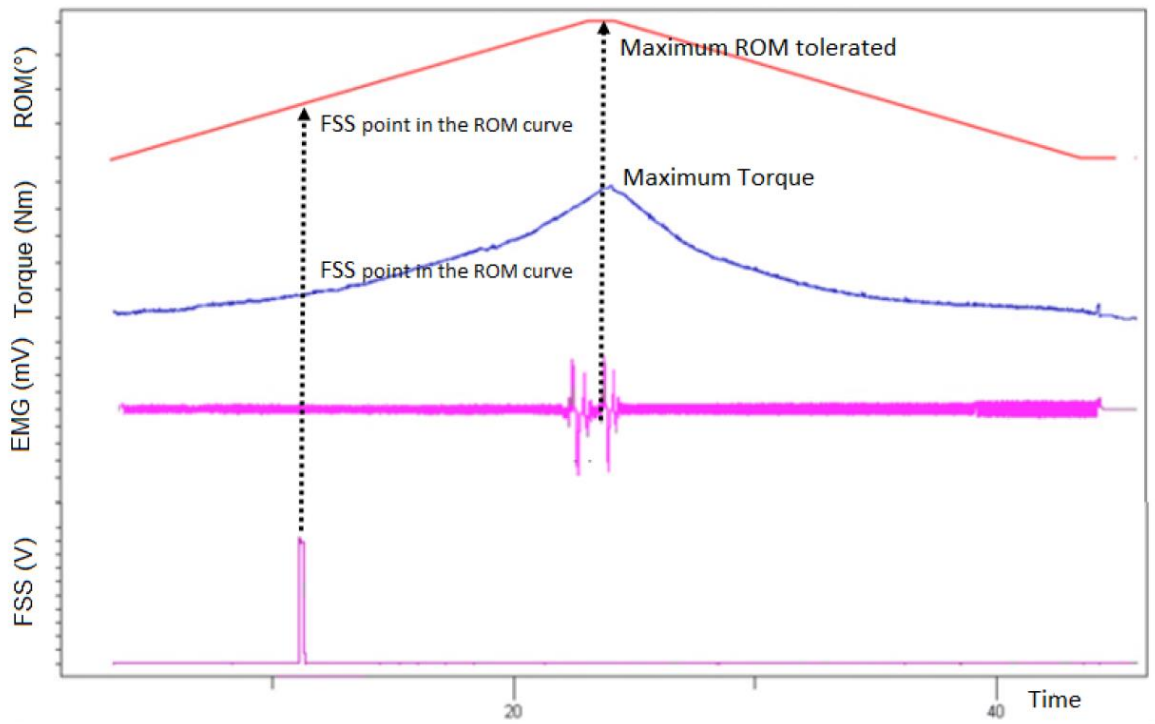

Figure 9: First sensation of stretch and respective values for torque and ROM. Note: image is a typical curve recorded during tests.

Both, the FSS and the maximal stretch tolerated (MST) (represented by the $\text{torque}_{\text{Max}}$ and its respective value for the ROM - ROM_{Max}), are expected to provide mechanical stimuli as sensory inputs to be captured by free ending receptors (Avela et al., 1999), the nociceptors. However, the threshold of the mechanical tension provided by stretching to stimulate the mechanoreceptors has seldom been measured if at all (Table 4).

Table 4: Physical possibilities for the understanding of the MTU response to stretching

First sensation of stretch (FSS)			Maximal stretch tolerated (MST)		
$\text{FSS}_{\text{Torque}}$	FSS_{ROM}	Property	$\text{Torque}_{\text{Max}}$	ROM_{Max}	Property
=	=	-	=	=	-
=	↑	Biomechanical	=	↑	Biomechanical
=	↓	Biomechanical	=	↓	Biomechanical
↓	↓	Sensory	↓	↓	Sensory
↑	↑	Sensory	↑	↑	Sensory
↑	=	Sensory	↑	=	Sensory
↓	=	Sensory	↓	=	Sensory

Specific concerns regarding pain and stretch among dancers have been identified regards to strength or ROM (Morrin and Redding, 2013, Smith et al., 2013). In addition, pain threshold and pain coping strategies in elite athletes have been documented in decathletes (Dale, 2000), combat athletes (Deroche et al., 2011), marathon runners (Johnson et al., 2012). Recent studies identified a pain modulation capacity in endurance athletes (Flood et al., 2017). As experimentally explored by Lima et al. (2017), the modulation can occur through either decreasing or increasing the pain sensations.

The sensory input from the body, thoughts, feelings, expectations and emotions may contribute to the neurological responses to sensations (Claus and MacDonald, 2017), pain-related psychological variables, such as mental toughness (Levy et al., 2006, Crust and Keegan, 2010) or self-efficacy (Nwankwo and Onyishi, 2012) are also likely to mitigate the sensation of pain. Therefore, the pain coping strategies differences between the general population and elite athletes have been robustly documented (Azevedo and Samulski, 2003).

Pessali-Marques (2015) compared the FSS and ROM_{Max} among trained (dancers) and non-trained in flexibility subjects. The non-trained group had an increase in the FSS alongside the ROM_{Max} increase, supporting the previous mentioned studies. The dancers, however, did not show any difference in the FSS, but a decrease in the corresponding torque, indicating that the FSS was signalled with a lesser resistance torque. Therefore, it would be likely to expect any change in the ROM_{Max} would not have happened. Surprisingly, the ROM_{Max} after the stretch intervention was greater for the dancers when compared to the non-trained group. Due to the lack of literature comparing trained and non-trained in flexibility subjects, these results need to be investigated further. To date, there is no clear explanation in the literature regarding the mechanisms related to stretch tolerance. Indeed, disentangling stretch sensation from pain sensation is a preliminary step to a better understanding of MTU behaviour to stretch from a sensory perspective.

1.4 Strength training

The muscle's ability to produce muscular work is directly related to performance in dance and sport alike (Angioi et al., 2009a). Moreover, jump ability is considered the best predictor

for the aesthetic competence in contemporary dancers (Angioi et al., 2009b). Jumps are dynamic movements (Yoshioka et al., 2010) with high upper and lower limbs coordination (Markovic et al., 2004). They are essential in many sports (Newton et al., 2006, Menzel et al., 2013a) as they are in dance performance (Wyon et al., 2006).

Jump height is crucial for dancers as they are expected to achieve exciting and dramatic elevation (Koutedakis et al., 2005). However, when compared to physically active control participants, dancers do not, in fact, jump significantly higher (Harley et al., 2002). Whilst it is clear that jump height can be increased with training (Crewther et al., 2006), there is evidence to suggest that dancers either do not undertake sufficient supplementary training or that the training may be ineffective (Wyon et al., 2006).

Several factors may affect vertical jump performance, such as lower body muscle strength, the rate of force development, the contraction speed (whilst maintaining a constant force output), the ability to utilize the stretch-shortening cycle (to maximize the jump height), and the degree of coordination.

Besides the crucial role of jumps' in the dance movements, many physical capacities may be evaluated through jump execution, such as maximal force (McElveen et al., 2010, Cordova and Armstrong, 1996), impulse (McElveen et al., 2010, Cordova and Armstrong, 1996), motor function (Cordova and Armstrong, 1996) and limb asymmetries (Menzel et al., 2013a).

1.4.1 Variables involved in the jump performance: definition

Vertical jump performance requires great power; that is, the ability to exert force rapidly through a vertical distance. The maximal power is the maximal value of the instantaneous power calculated with the instantaneous vertical reaction force measured during the jump. The take-off velocity ultimately determines the jump height and the vertical jumping ability; it is usually estimated by the height achieved in the vertical jump (Figure 10).

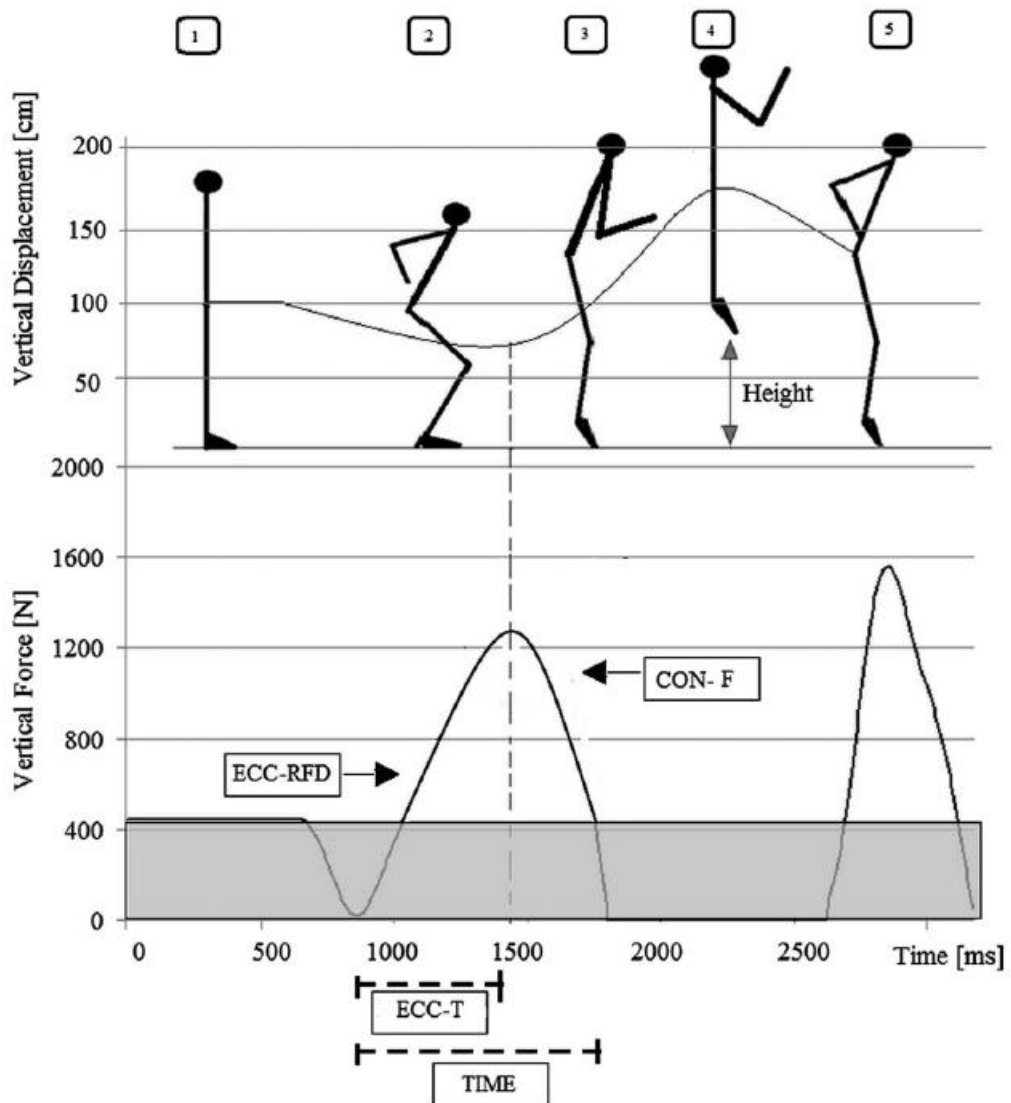

Figure 10: Vertical Force and vertical displacement over time. Modified from Brady et al. (2017)

Force platforms are considered the gold standard in the jump analyses, conferring the force applied by the time according to the third Newton law. The maximal force is the greatest value in the Force-Time curve obtained in the impulsion moment of the jump. The impulse is determined by the integral of the Force-Time curve and it is represented by the area under the curve (Figure 11). The impulse and maximal force may be obtained direct from the force platform (Meylan et al., 2010).

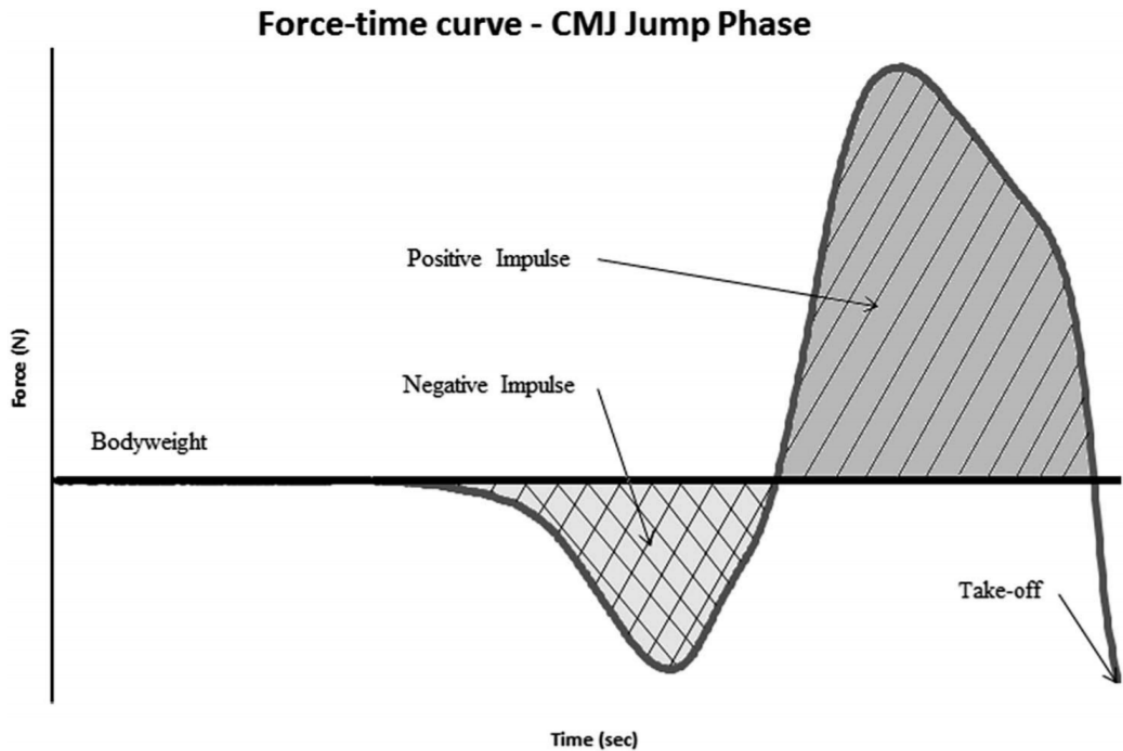

Figure 11: Force – Time curve. Modified from Brady et al. (2017).

In addition, the training of isolated vertical jump components may allow jump performance improvement (Table 5).

Table 5: The assessment of vertical jump components

Vertical jump component	Test characteristics
Maximal strength	Squat or leg press
Maximal force of rate development	Contact time during drop jump when jumping for minimum contact and maximal height
Stretch-shortening cycle ability	Difference between squat jump and counter-movement jump heights
Maximal mechanical power	Highest power output during vertical jumps with increasing loads or increasing drop heights
Jumping skills and muscle coordination	Technique analysis; i.e. the difference between jump with and without arm/trunk movement

The use of equipment for the jump analysis may provide important additional information; Goniometers or video analysis, for example, may allow the joint angles evaluation; thus, the technique may be enhanced. In addition, the associated muscle electromyography activity (EMG) would allow comparisons between contralateral limbs, muscle groups or intervention results (Menzel et al., 2013a).

The squat jump (SJ) and the countermovement jump (CMJ) are two common techniques that are used in researches protocols; both are a closed kinematic chain of movement. However, the SJ is a pure concentric muscle action while the CMJ is a combination of eccentric and concentric muscle action, using the stretch-shortening cycle (Schmidtbleicher, 1992).

When a muscle shortens (concentric muscle action) it performs positive work. When a muscle is forcibly stretched (eccentric muscle action), the external force does work on the muscle. There are two flows of energy: to the muscle—external force does work on the muscle, and the muscle spends energy to provide resistance against the external force. A higher contractile force is generally observed when an active muscle is stretched immediately before shortening (Bobbert et al., 1996), in a degree of activation level-dependent fashion (Onambélé et al., 2004). Many movements such as running, cycling, jogging, swimming (Witvrouw et al., 2004), throwing, besides jumping involve muscle actions in which the desired motion is preceded by a movement in the opposite direction (Linthorne, 2001). The combination of lengthening (eccentric phase) and shortening (concentric phase) is known as a stretch-shorten cycle (SSC) and has shown to enhance performance (Bobbert et al., 1996, Witvrouw et al., 2004). The (SSC) may be divided into two categories: the short stretch-shorten cycle (>0.200 m/s) and the long stretch-shorten cycle (<0.200 m/s) (Young et al., 1995).

Linthorne (2001) highlighted that the SJ is a slightly artificial movement that is rarely used in practice, in opposition; the CMJ is a natural jump technique. The author also suggested that most people could jump several centimetres higher in a CMJ than in an SJ. Indeed, researchers found a greater jump height of approximately 12-18% in the CMJ compared to the SJ. For the SJ, the participant squat flexing hips and knees at approximately 90 degrees, this position is sustained for a brief period and followed by a concentric muscle action upwards. Differently, for the CMJ, participant stands in the anatomical position, there is an initial eccentric muscle action downwards immediately followed for a concentric muscle action upwards (Padulo et al., 2013, Menzel et al., 2013b, McErlain-Naylor et al., 2014). Considering that, a significant increase in the jump height with the participation of the arms

in the movement was found in some studies, the arms should remain in the hips to avoid any influence (Vaverka et al., 2016, Lees et al., 2004, Shadmehr et al., 2016).

The SJ and the CMJ may be executed bilaterally or unilaterally. In addition, when each foot is positioned above two separate force platforms asymmetries may be analysed (Menzel et al., 2013a). Given that the MTU may generate forces either as an elastic-like spring (i.e. SSC) or through metabolic energy conversion into mechanical work (i.e. predominantly concentric actions), the difference in the height between these two jumps is used to infer the participation of the elastic components of the muscle in the movement. The strain energy is stored in the tendon structures as elastic energy during eccentric actions. The storage and release of elastic energy during the SSC have been generally considered as an “energy-saving” mechanism (Witvrouw et al., 2004).

2. Thesis Aims

Considering that flexibility and strength components could be influenced by S_{MTU} (Brughelli and Cronin, 2008b), and S_{MTU} being affected by many factors including the key menstrual cycle hormones (Onambélé et al., 2007b), it is necessary to determine the factors that might affect S_{MTU} and, therefore, physical performance in dancers.

2.1 Aim

To determine the modification of S_{MTU} and its characteristics, especially through the menstrual cycle phases, that may affect jump and flexibility performance in dancers and non-dancers.

2.2 Objectives

- To develop and validate a piece of equipment to measure and train flexibility in high flexible participants (chapter 1).
- To determine and compare the structural and functional characteristics of the MTU in dancers and non-dancers (chapter 2).
- To determine whether asymmetries in flexibility between the limbs may affect kinetic variables and, therefore, performance in jump and flexibility movements (chapter 3).
- To determine whether asymmetries in flexibility between the limbs may affect kinematic variables and, therefore, performance in jump and flexibility movements (chapter 4).
- To evaluate the acute influence of a stretching protocol on flexibility and jump performance in dancers through the modification in the S_{MTU} (chapter 3 and 4).
- To determine whether the different phases of the menstrual cycle influence performance in jumps and flexibility in dancers (chapter 5).
- To determine whether the changes in pain perception against the MCP influence performance in jump and flexibility (chapter 5).
- To determine any interaction between MTU structural and functional characteristics, against the MCP (chapter 5).
- To determine whether the hormonal concentration of female hormones and the oral contraceptive pill affects flexibility performance in jump in dancers and non-dancers (chapter 2 to 5).

Overall Methods

"Equipado com seus cinco sentidos, o homem explora o universo ao seu redor e chama a aventura de ciência."

Edwin Powell Hubble

"Equipped with his five senses, man explores the universe around him and calls the adventure Science"

Edwin Powell Hubble

In the overall methods of this experimental research the ethics, participants (Table 6 p54), equipment, protocols and tests performed will be described as they are duplicated in some studies (Table 7 p55), outcome variables are summarised in Table 8 p56. Information about sample size, procedures and data analyses will be described separately in the methods section of each chapter according to their aim.

3.1 Ethics

The Manchester Metropolitan University Department of Exercise and Sport Science Sub-Committee granted ethical approval by the number 22.12.15 (ii). The study was performed in compliance with the Declaration of Helsinki. Participants who have agreed to take part in this study received all the information about the aims and procedures and read the Participant Information Sheet⁵, before signing the Informed Consent Form⁶ prior to data collection.

3.2 Participants

GPower (v3.1.9.2 Heinrich Heine Universität Düsseldorf, Germany) was used for the calculation of the sample size, *a priori*, using the effect size = 0.8 obtained from a study with similar variables (Pessali-Marques, 2015), the power and the significance level were established as $\beta=0.8$ and $\alpha=0.05$, respectively. Accordingly, the sample size was set as 15 volunteers per group; the power and effect size, *a posteriori*, will be presented in the results section of each data chapter.

Fifty female participants engaged in this study. Inclusion criteria comprised the absence of injuries in the lower back and lower limbs in the last month or previous injuries that could be aggravated by the research protocols. Thirty undergraduate contemporary dance students with a minimum of 10 hours per week of dance practice for at least 3 years constituted the dancers' sample and twenty undergraduate sport science students formed the non-dancers' group. Participants from the dancers' sample were further sub-divided into two groups according to their contraception status; 1) the use of uninterrupted hormonal contraception, either combined or progesterone only, for 6 months and, 2) the absence of

⁵ Appendix U pages 334 and 335

⁶ Appendix T page 333

pharmaceutical contraception. Participants from the non-dancers' group were not under contraception. Table 6 shows the characteristics of each group.

Table 6: Characterisation of the participants in the overall thesis' research (average \pm standard deviation)

Group	n	Contraception Status	Age (years)	Body mass (kg)	Height (m)
<u>D</u>ancers <u>C</u>ontemporary (DCT)	15	<u>T</u>aking either Progesterone or Combined pill	21 \pm 7	65.83 \pm 2.8	1.61 \pm 0.03
<u>D</u>ancers <u>C</u>ontemporary (DCN)	11	<u>N</u>ot under contraception	23.5 \pm 2.94	67.65 \pm 15.62	1.63 \pm 0.05
<u>N</u>on-Dancers (NN)	20	<u>N</u>ot under contraception	22.4 \pm 1.77	65.06 \pm 15.59	1.64 \pm 0.05

One participant of the DCN dropped out from the study without specifying a reason and the other three participants were excluded, from those, one participant from the DCN was excluded due to incorrect information about her contraceptive status (her implant was not expired as she thought it was) and two participants from the DCT were excluded due to incorrect contraception ingestion, therefore, 46 participants completed the studies. A summary of the data chapters' test, protocols and variables are presented in Table 7, followed by a description of all variables presented in Table 8.

Table 7: Data chapter tests, protocols and variables of the current thesis.

Data Chapters	Data collection sessions	N Group	Passive Flexibility	CMJ/SJ	Jump kinematics	Intervention stretch training	Pain mix method	EMG	Ultrasound	Hormone and whole blood
Chapter 1 - Equipment development	1) Familiarisation 2) Data collection (24 – 48 hours after familiarisation)	17 DCT	ROM _{Max} Torque _{Max} FSS _{ROM} FSS _{torque}	-	-	Passive stretching with constant torque	-	-	-	-
Chapter 2 - Any Modulation of flexibility by muscle structure and function in young active females: Non-dancers vs dancers	1) Familiarisation 2) Data collection (Ovulatory phase of the menstrual cycle)	20 NN 11 DCN	ROM _{Max} Torque _{Max} FSS _{ROM} FSS _{torque} S _{MTU} Energy	Jump height Impulse Force _{peak} V _{take-off}	-	-	SEFIP PASS VAS Ice Water Test	EMG _{ST} EMG _{RF} during CMJ and SJ	CSA Length Width Fat thickness Lean thickness Semitendinosus thickness	Oestrogen Progesterone Relaxin (serum) Cholesterol Lactate Glucose Triglycerides
Chapter 3 - Impact of an acute stretch intervention on the Modulation of flexibility by muscle structure and function in dancers	1) Familiarisation 2) Data collection (24 – 48 hours after familiarisation)	15 DCT	ROM _{Max} Torque _{Max} FSS _{ROM} FSS _{torque} S _{MTU} Energy	Jump height Impulse Force _{peak} V _{take-off}	-	Passive stretching with constant torque	-	-	-	Oestrogen Progesterone (saliva)
Chapter 4 - Impact of an acute stretch intervention on the jump kinematics in dancers	1) Familiarisation 2) Data collection (24 – 48 hours after familiarisation)	15 DCT	ROM _{Max} Torque _{Max}	Jump height Force _{peak}	Knee, Ankle, Hip angles and angular velocity	Passive stretching with constant torque	-	EMG _{ST} EMG _{RF} during CMJ and SJ	-	Oestrogen Progesterone (saliva)
Chapter 5 - Effect of Menstrual Cycle Phase (peak vs trough oestrogen) in dancers in terms of – the Modulation of flexibility by muscle structure and function	1) Familiarisation 2) Data collection (Ovulatory, Luteal and Follicular phases of the menstrual cycle)	11 DCN	ROM _{Max} Torque _{Max} FSS _{ROM} FSS _{torque} S _{MTU}	Jump height Impulse Force _{peak} V _{take-off}	-	-	SEFIP PASS VAS Ice Water Test	EMG _{ST} EMG _{RF} during CMJ and SJ	CSA Length Width Fat thickness Lean thickness Semitendinosus thickness	Oestrogen Progesterone Relaxin (serum) Cholesterol Lactate Glucose Triglycerides

Table 8: Summary of all outcome variables.

Variable	Unit	Description
D	-	The dominant limb which presented larger ROM in the flexibility Pre-test
nD	-	The non-dominant limb which presented smaller ROM in the flexibility Pre-test
ROM _{Max}	°	ROM _{Max} was defined as the maximal ROM tolerated by the participant measured in the Flexibility Test Equipment (FTE).
Torque _{Max}	N	The resistance torque measured in the Flexibility Test Equipment (FTE) and corresponded to the ROM _{Max} was named torque _{Max} .
FSS _{ROM}	°	The ROM value in which participants signalled a tension in the stretched muscles measured in the Flexibility Test Equipment (FTE).
FSS _{torque}	N	The torque value in which participants signalled a tension in the stretched muscles measured in the Flexibility Test Equipment (FTE).
S _{MTU}	N/°	Muscle tendon-unit stiffness calculated by the variation of the range of motion (ROM) divided by the variation of the torque measured in the Flexibility Test Equipment (FTE)
Energy	Nm°	The potential energy stored when the MTU is stretched; calculated by the area under the length (ROM) x tension (torque) measured in Flexibility Test Equipment (FTE).
Jump height	cm	The highest point that a determinate body landmark reaches during CMJ and SJ from a standing position measured on the force platforms using the flight time.
Total force _{peak}	N	Greatest recorded instantaneous force produced during the CMJ and SJ combining results from both force platforms, therefore, both lower limbs.
Total impulse	Ns	Greatest force multiplied by the time of the force production during the CMJ and SJ measured on the force platforms combining results from both force platforms, therefore, both lower limbs
V _{take-off}	m/s	Velocity during the CMJ and SJ take-off phase measured on the force platforms.
Force _{peak}	N	Greatest recorded instantaneous force produced during the CMJ and SJ.
Impulse	Ns	Greatest force multiplied by the time of the force production during the CMJ and SJ measured on the force platforms.
EMG _{ST}	μV	Electromyographic activity of the semitendinosus during the CMJ and SJ.
EMG _{RF}	μV	Electromyographic activity of the rectus femoris during the CMJ and SJ.
Length	mm	Distance from the head of the femur to the lateral epicondyle measured with a measuring tape.
Width	mm	The medial and lateral boundaries of the semitendinosus were identified in the transverse plane; the edges of the muscles were marked on participant's skin with a pen and measured with a measuring tape.
ST thickness	mm	Distance from the superficial and deep aponeurosis of the semitendinosus measured using the ultrasound.
Fat thickness	mm	Distance from the subcutaneous adipose tissue to the muscle interface measured using the ultrasound.
Lean thickness	mm	Distance from the superficial aponeurosis to the muscle-bone interface measured using the ultrasound.
CSA	mm ²	Area of the muscle cross-section in the transversal plane measured using the ultrasound.
Total PASS score	-	The sum of the scores obtained in each one of the scales assessed on the PASS questionnaire.
Mode PASS score	-	Mode of the scores obtained in each one of the scales assessed on the PASS questionnaire.
PASS cog anx	-	Score related to cognitions related to pain anticipation assessed on the PASS questionnaire.
PASS escape	-	Score related to withdrawal behaviours related to actual pain or the anticipation of pain assessed on the PASS questionnaire.
PASS fear	-	Score related to actual fearful thoughts (often intrusive) related to the experience or anticipation of pain assessed on the PASS questionnaire.

PASS physio	-	Score related to the bodily reaction when experiencing or anticipating pain assessed on the PASS questionnaire.
Age	years	Number of years that a person has lived.
Height	m	The length of the human's body, from the bottom of the feet to the top of the head in an orthostatic position, looking forward, bare feet and closed feet measured using a stadiometer.
Mass	kg	The intrinsic property of the human body measured in an orthostatic position, looking forward, bare feet on top of a scale.
Fat	%	Percentage of body fat tissue measured through bioelectrical impedance analysis.
Fat	kg	The mass quantity of body fat tissue measured through bioelectrical impedance analysis.
Lean	%	Percentage of body muscle tissue without fat measured through bioelectrical impedance analysis.
Lean	kg	The mass quantity of body muscle tissue without fat measured through bioelectrical impedance analysis.
Water	%	Percentage of body water measured through bioelectrical impedance analysis.
Water	L	The volume of water in the body measured through bioelectrical impedance analysis.
Basal metabolism	j	The minimum amount of energy required to maintain vital functions in an organism at complete rest, measured by the basal metabolic rate through bioelectrical impedance analysis.
Body mass index	kg/m ²	The measure of body composition based on height and body mass measured through bioelectrical impedance analysis.
Cholesterol	mmol/L	A compound of the sterol type found in most body tissues obtained through fasting plasma analysis.
Triglycerides	mmol/L	Fatty compounds synthesized from carbohydrates during the process of digestion and stored in the body's adipose (fat) tissues obtained through fasting plasma analysis.
Glucose	mmol/L	A monosaccharide sugar used by living things to obtain energy. Obtained through fasting plasma analysis.
Lactate	mmol/L	A salt or ester of lactic acid obtained through fasting plasma analysis.
IWT duration	s	Physiologic test for the general pain tolerance assessment.
VAS	-	Visual analogue scale: numeric visual 10-point scale
Total SEFIP	-	The sum of the scores obtained in each one of the scales assessed on the SEFIP questionnaire.
Mode SEFIP	-	Mode of the scores obtained in each one of the scales assessed on the SEFIP questionnaire.
Progesterone	pg/ml	A female steroid sex hormone obtained through fasting plasma or saliva analysis.
Oestrogen	pg/ml	A female steroid sex hormone obtained through fasting plasma or saliva analysis.
Relaxin	pg/ml	A female steroid sex hormone obtained through fasting plasma or saliva analysis.
Calf circumference	cm	Circumference measured at the greatest girth.
Thigh circumference	cm	Circumference measured at the medial point between the upper anterior iliac crest and the patella.
Hips circumference	cm	Circumference measured in the height of the head of the femur.
Waist circumference	cm	The smallest circumference in the trunk. Arms remain crossed with hands touching the shoulders.
H_a	°	The hip angle measured in each of the four CMJ and SJ phases: preparatory squat, take-off, landing and landing squat.
K_a	°	Knee angle measured in each of the four CMJ and SJ phases: preparatory squat, take-off, landing and landing squat.

A_a	°	Ankle angle measured in each of the four CMJ and SJ phases: preparatory squat, take-off, landing and landing squat.
H_v	°/s	Hip angular velocity measured in the eccentric and concentric phases of the CMJ and SJ.
K_v	°/s	Knee angular velocity measured in the eccentric and concentric phases of the CMJ and SJ.
A_v	°/s	Ankle angular velocity measured in the eccentric and concentric phases of the CMJ and SJ.

3.3 Equipment

The equipment used for the tests, calibration, reliability, test protocols and data processing will be detailed in this section. The order of tests for each study will be described in the procedures of each data chapter methods section, according to their aim.

3.3.1 Menstrual calendar, basal thermometer, and ovulation kit

A menstrual calendar identifying time-of-day for sampling, armpit temperature and menstrual cycle phase (Appendix F); a digital basal thermometer (Geratherm, Geratherm Medical, Geschwenda, Germany) with accuracy of $\pm 0.10^{\circ}\text{C}$, range of 32 to 43.99°C, liquid crystal display four digits; and, five strips of urine test One Step Ultra Early Pregnancy Tests at 10 mIU/mL (One+Step®, Germany) were given to eumenorrhic (non-users of contraceptive medication) participants, to accurately track each participant's menstrual cycle.

Instructions were that the basal temperature should be measured daily just after waking up and written down in C° with two decimal places alongside the time-of-day. The menstruation phase was also to be highlighted in the calendar. To confirm the ovulation phase, an ovulation kit was given to participants to be used from five days preceding the predicted ovulation. The ovulation kit consists of colourimetric enzyme immunoassays of urinary LH. Once the LH surge has been shown to occur the ovulation is expected to take place within the next 14-26 hours (Miller and Soules, 1996). The test is composed of five strips of a urine test (One+Step, Germany), with participants collecting a urine sample in a clean and dry container and placing said test strip vertically into the urine sample for at least 10 seconds, then removing the strip and placing it on a clean and dry surface. Positive results were visible after one minute through a coloured band. To confirm a negative result, the full reaction time of 10 minutes was required. The participant had to repeat the test using one strip per

day until ovulation was confirmed. At this point, they had to call the researcher to book the tests.

3.3.2 Venepuncture & blood/sera analyses

Sera samples were used to analyse the concentration of hormones in the different phases of the menstrual cycle. Participants attended the Phlebotomy Laboratory at Manchester Metropolitan University in the morning after an overnight fast of 12 hours. Participants were requested to drink 500 ml of water just after waking up (approximately two hours before the data collection) to guarantee adequate hydration level according to the recommendations of the American College of Sports Medicine (ACSM) for the blood samples collection. The blood was collected by a trained phlebotomist in one of the veins of the antecubital fossa (medial cubital vein, basilic vein or the cephalic vein). The suitable vein may differ between participants and was chosen by palpation using the index finger. The skin was disinfected with an alcohol wipe (BlueSensor M, Ambu, Copenhagen, Denmark) and a reusable tourniquet was applied seven-10 centimetres above the cubital fossa. A disposable needle size 21g (Hamilton Gastight Bonaduz, Switzerland) attached to a syringe 10 ml (Hamilton Gastight Bonaduz, Switzerland) ml was inserted and 5 ml of venous blood was collected and stored in a BD Vacutainer Rapid Serum RST Tubes (BD Worldwide, New Jersey, USA). The containers were kept on crushed ice until the centrifugation. After 15 minutes (preparation time), samples were centrifuged at 4000 rpm, for 10 minutes, at room temperature (Hermle Z380 Beckman Coulter, California, USA). Serum was then extracted from each test tube using a pipette (Eppendorf, Hamburg, Germany) and stored in 1 ml aliquots in collection tubes 3810X (Eppendorf, Hamburg, Germany). Eppendorf's were coded to maintain participants' anonymity and stored at -20°C for later analysis.

Whole blood analysis of fasting plasma glucose, total cholesterol and triglycerides were performed immediately using an Accutrend Plus (Roche Diagnostics Limited, Welwyn Garden City, UK) monitoring device and Accutrend test strips (Roche Diagnostics Limited, Welwyn Garden City, UK). The remaining blood in the syringe was placed in the strip and the strip was placed in the monitor device. Coqueiro et al. (2014) investigated the accuracy and precision of this system in adults and found it to be a valid device. Accutrend Plus showed to be accurate ($p \leq .05$) for the glucose and the triglycerides but not of total cholesterol ($p >$

.05) when compared to laboratory tests. However, the system showed good reproducibility (Lin's coefficient: glucose = 0.958, triglycerides = 0.992, total cholesterol = 0.940), high concordance with the laboratory method (Lin's coefficient: glucose = 0.952, triglycerides = 0.990, total cholesterol = 0.944), high sensitivity (glucose = 80.0%, triglycerides = 90.5%, total cholesterol = 84.4%) and specificity (glucose = 100.0%, triglycerides = 96.9%, total cholesterol = 95.2%). Scafoglieri et al. (2012) assessed its reproducibility, accuracy and concordance for blood lipid profiling in adults. They found high reproducibility for the day-to-day assessment of total cholesterol (ICC = 0.85, $p < 0.001$), moderate for total glycerides (ICC = 0.68, $p < 0.001$) and strong correlations ($r \geq 0.80$, $p < 0.001$) with the reference laboratory method for both.

3.3.3 Endocrine Analyses

Commercially available enzyme-linked immunosorbent assay (ELISA) kits were used to determine the concentration of serum oestradiol (here thereafter called oestrogen), progesterone and relaxin, as well as saliva oestradiol (here thereafter called oestrogen) and progesterone. Samples were removed from the freezer two-hour before analyses to thaw at room temperature. Table 9 shows the specific concentration of reagents specified from each manufacturer.

ELISA assay was performed in 96 well plates, allowing multiple samples to be measured in a single experiment. These plates are special absorbent plates to ensure the antibody or antigen to stick to the surface. Each ELISA measures a specific antibody (e.g. oestrogen, progesterone or relaxin). The sandwich ELISA is composed of two sets of antibodies to detect secreted products and it consists of three steps. i) The ELISA plate is coated with a capture antibody, covered, and incubated. Any excess, unbound antibody, is then washed from the plate using wash buffer in the concentration stipulated by the manufacturer. For the manufactures who sent the wash buffer in a concentrated solution, dilution was performed as stipulated and mixed gently using a Magnetic Stirrer (in this research the HI 190M, Hanna Instruments Woonsocket, Rhode Island, EUA was used) until the crystals have completed dissolved at room temperature. The manufacturer stipulates volume (table 8) of wash buffer was applied using a 12 channel Multichannel Pipette (Thermofisher Scientific, Rochford, United Kingdom) and, an inversion dabbing and buffing method was performed four times.

ii) sample, either fresh whole or diluted according to the manufacturer specifications (Table 9) is added to the plate; any antigen found in the sample will bind to the capture antibody already coating the plate. The detection antibody is added to the appropriate wells, which will bond to any target antigen already bound to the plate. Thereafter, the well is incubated at room temperature on a shaker (in this research the 3D Rocking Platform STR9, Stuart Scientific, Staffordshire, UK, was used). Again, any excess sample was washed from the plate using the aforementioned inversion and dabbing method. iii) Substrate Solution is added to each well and incubated at room temperature on the benchtop, protected from light. Finally, Stop Solution is added to each well.

Table 9: Assay procedures for the Endocrine Analyses performed in the current thesis.

	Serum Oestrogen	Serum Progesterone	Serum Relaxin	Saliva Oestrogen	Saliva Progesterone
Manufacture	R&D Systems, Bio-technie, Minneapolis, Minnesota, EUA	Abxexa, Cambridge, UK	R&D Systems, Bio-technie, Minneapolis, Minnesota, EUA	Demeditec Diagnostics, Kiel, Germany	Demeditec Diagnostics, Kiel, Germany
Sample dilution		1:10 for concentrations between 20ng/ml – 200 ng/ml			
Standard solution	100 µL	50 µL	100 µL	100 µL	50 µL
Incubation	60-min at room temperature in a mixer			30-min at room temperature	
Wash	4 times: wash buffer soaking – inversion - dabbing				
Sample Antibody	100 µL 50 µL	50 µL 50 µL	50 µL	200 µL	100 µL
Incubation	120-min at room temperature in a mixer (3D Rocking Platform STR9, Stuart Scientific, Staffordshire, UK)	45-min at 37°	120-min at room temperature	120-min at room temperature	60-min at room temperature in a mixer (3D Rocking Platform STR9, Stuart Scientific, Staffordshire, UK)
Wash	4 times: wash buffer soaking – inversion - dabbing	3 times: wash buffer - 1 min soaking – inversion - dabbing	4 times: wash buffer soaking – inversion - dabbing	4 times: wash buffer - inversion - dabbing	4 times: wash buffer - inversion - dabbing
Working solution	200 µL	100 µL	200 µL		
Incubation	30-min at room temperature in the dark on the benchtop	30-min at 37°	120-min at room temperature		
Wash		5 times: wash buffer - 1 min soaking – inversion - dabbing	4 times: wash buffer – inversion - dabbing		
Substrate		90 µL	200 µL	200 µL	200 µL
Incubation		15-min at 37° in the dark	30-min at room temperature in the dark	30-min at room temperature	30-min at room temperature in the dark
Stop solution	100 µL	50 µL	50 µL	100 µL	50 µL
Reading	450 nm with wavelength correction of 540 or 570 nm if necessary	450 nm	450 nm with wavelength correction of 540 or 570 nm if necessary	450 nm with wavelength correction up to 10-min after the stop solution	450 nm

ELISA assays are usually chromogenic using a reaction that converts the substrate into a coloured product. The colour in the wells should change from blue to yellow, which can be measured using a microplate reader (in this research the EL 808, Biotek, Winooski, USA) using the recommended wavelength and any optical imperfections correction if necessary and where available a data reduction software (in this case Gen5, Biotek, Winooski, USA) to calculate each well's ligand concentration based on the calibration curve.

For the ligand calibration curve, each company recommends a series dilution of the standard substrate which they provide (Figure12).

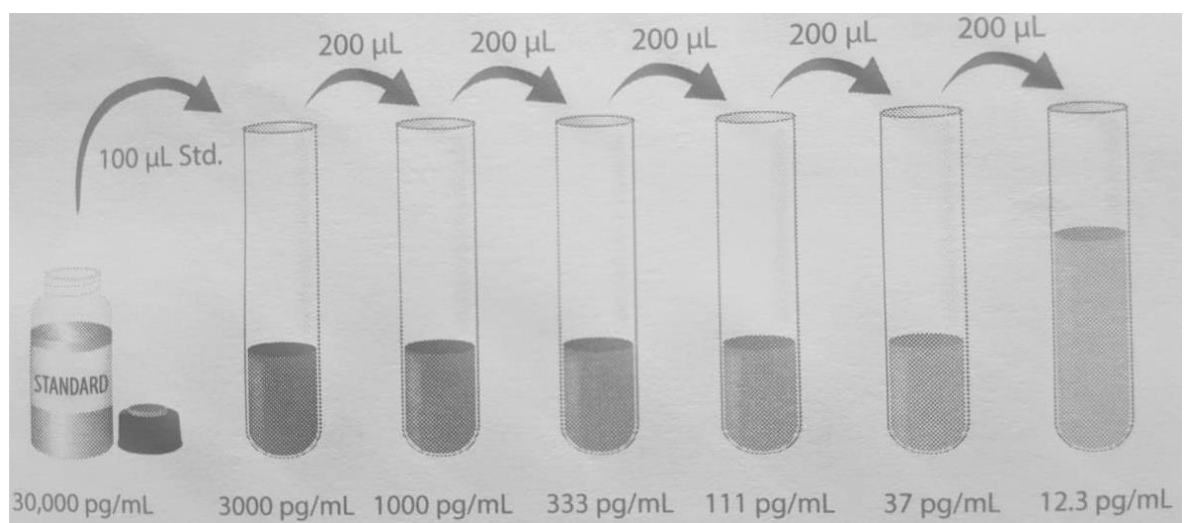

Figure 12: Example of Calibration series dilution recommended for the serum oestrogen analysis by the R&D Systems, Bio-technie, Minneapolis, Minnesota, USA.

3.3.4 Ultrasound Imaging

Ultrasound assessments were performed using (MyLab™Gamma; Esaote, Reading, Berks, UK) with a scanning frequency of 7.50 MHz, in Brightness-mode or B-mode using the following settings: depth of penetration 49.3 mm, depth of focus 27.0 – 31.0. Live streaming of all assessments was collected on a Hewlett-Packard computer running video capture software (Premier 6.0, Adobe Systems, San Jose, USA) through an analogue to digital converter (Pinnacle, Corel Inc., Ottawa, Canada). The depth of the transducer penetration was noted to allow for video scaling during post hoc analyses using ImageJ (Fiji software, Bethesda, USA).

The B mode ultrasound is a useful tool for imaging soft tissue. Its mode of operation is via the transmission and reception of sound waves produced by oscillating crystals at a frequency that is inaudible to the human ear. Transducers located in the probe produce sound (for example) at 7.5 MHz, which is then pulsed at intervals that occur every 20 microseconds. These sound waves penetrate and encounter the different tissue interfaces as they travel through the body. When sound encounters tissues or tissue planes, part of the wave is reflected back to the receivers in this same probe. The transducer must be in contact with the medium scanned, in this case, the skin, so a transmission gel is used to ensure a complete union and improve conduction, in other words, to achieve acoustic contact.

This B-mode analyses the intensity of the returning ultrasound signal as well as the direction and depth from, which it is reflected. A two-dimensional grey-scale image is constructed with different intensities from the returning signals being assigned different levels of brightness. Generally, a high-density structure such as tendon/bone will reflect a high-intensity signal back to the probe and be displayed as white on the screen.

For the assessment participants laid supine on a physiotherapy bed to minimise any muscular contraction, with participants relaxed in an extended position during the measurements. B-mode ultrasound (MyLab™Gamma; Esaote, Reading, Berks., UK) with a 7.5-MHZ linear-array probe was used for the scans of the muscles and a clear professional hypoallergenic water-soluble ultrasound transmission gel (Healthlife, Beauties Factory UK, Darlington, Durham, United Kingdom) was placed over the scan head to improve acoustic coupling.

All structural measures were taken at 50% length and mid-width of the thigh, with length measured from the head of the femur to the lateral epicondyle. The medial and lateral boundaries of the semitendinosus were identified in the transverse plane; the edges of the muscles were marked on participant's skin with a pen. The Cross-Sectional Area (CSA) scans were also conducted in the transverse plane (Figure 13). Thickness measurements of the semitendinosus (distance between the superficial and deep aponeurosis) were measured in the sagittal plane alongside with the fat thickness and total thickness (from the

subcutaneous adipose tissue-muscle interface to the muscle-bone interface (Figure 14). The accuracy of this procedure for the muscle thickness (MT) assessment was evaluated in previous research (Miyatani et al., 2001, Miyatani et al., 2004).

Ultrasound scans were recorded and digitised on a Hewlett Packard Windows laptop and analysed offline with digitizing software (Dartfish for video capture, Gimp for digital image manipulation and ImageJ for digital image measurement).

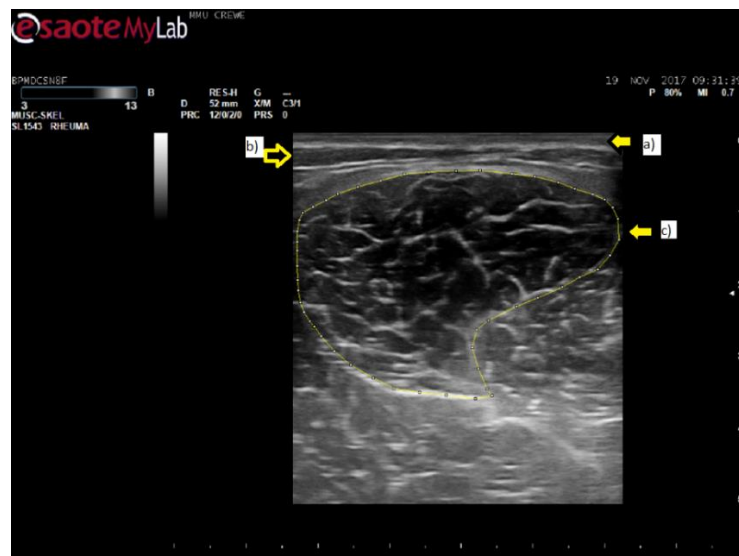

Figure 13: Semitendinosus Ultrasound Cross-sectional Area image. a) skin; b) subcutaneous fat; c) muscle aponeuroses. Note: image recorded during tests of the current thesis.

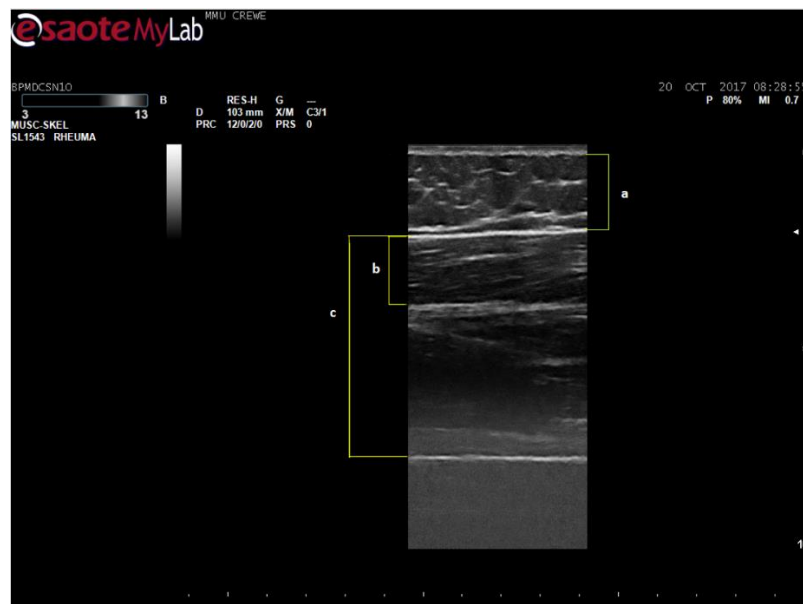

Figure 14: Ultrasound image a) Fat thickness b) Semitendinosus thickness c) Lean total thickness. Note: image recorded during tests of the current thesis.

Previous studies demonstrated a good agreement between the MRI and the ultrasound measurements of muscle thickness for the lower trapezius muscles (O'Sullivan et al., 2009a) and high interrater reliability, as well as high intrarater reliability for the thickness of the multifidus muscle by an experienced assessor and a novice assessor (Lee et al., 2018).

3.3.5 Passive Flexibility Test & Flexibility intervention

The Flexibility Test Equipment was used to measure the passive torque, passive ROM and First Sensation of Stretch (FSS). It was also used to test and to train the hamstrings flexibility through different stretching protocols. The equipment allows the measurement of the right and left lower limbs separately, with the participant lying supine on the equipment.

Participants were positioned supine on the table with the greater trochanter aligned with the rotation axis of the lever and the ankle held in support adjusted 2 cm proximal from the lateral malleolus. A load cell was coupled under this ankle support to measure MTU's resistance force against the stretching. In the initial position, participant laying supine on the table, the hip was considered 0° of hip flexion and could range to 180°; the knee was maintained at 0° of flexion during the whole stretch intervention. Straps on the ankle, distal third of the thigh and anterior superior iliac spines were used to fix the participant in this position. In addition, the thigh of the contralateral limb was strapped to the table and cushions underneath the lower back and neck were used both for comfort and to further minimise compensatory movements.

The participant manipulated two controls: 1) the first control with one button to ascend and another button to descend, the equipment lever arm; 2) the second control with a single button to be pressed at the first sensation of stretch, i.e. tension in the hamstrings (Figure 15).

For gravity correction, participants lay supine and the mass of their lower limb was measured with hip at 0° flexion and used to adjust the torque values according to equation 5⁷ detailed on Chapter 1.

⁷ Vide Chapter 1 page 89

The potentiometer, the load cell and the FSS dispositive (aforementioned as secondary control operated by the participant) are connected to an analogue/digital converter (NI USB-6008 National Instruments, Austin, Texas, EUA), itself connected to a desktop computer (Porgété Z30, Toshiba, Hammfelddamm, Neuss, Germany). The DasyLab program 11.0 (Dasytec Daten System Technik GmbH, Ludwigsburg, Germany) was also used for data acquisition and analysis.

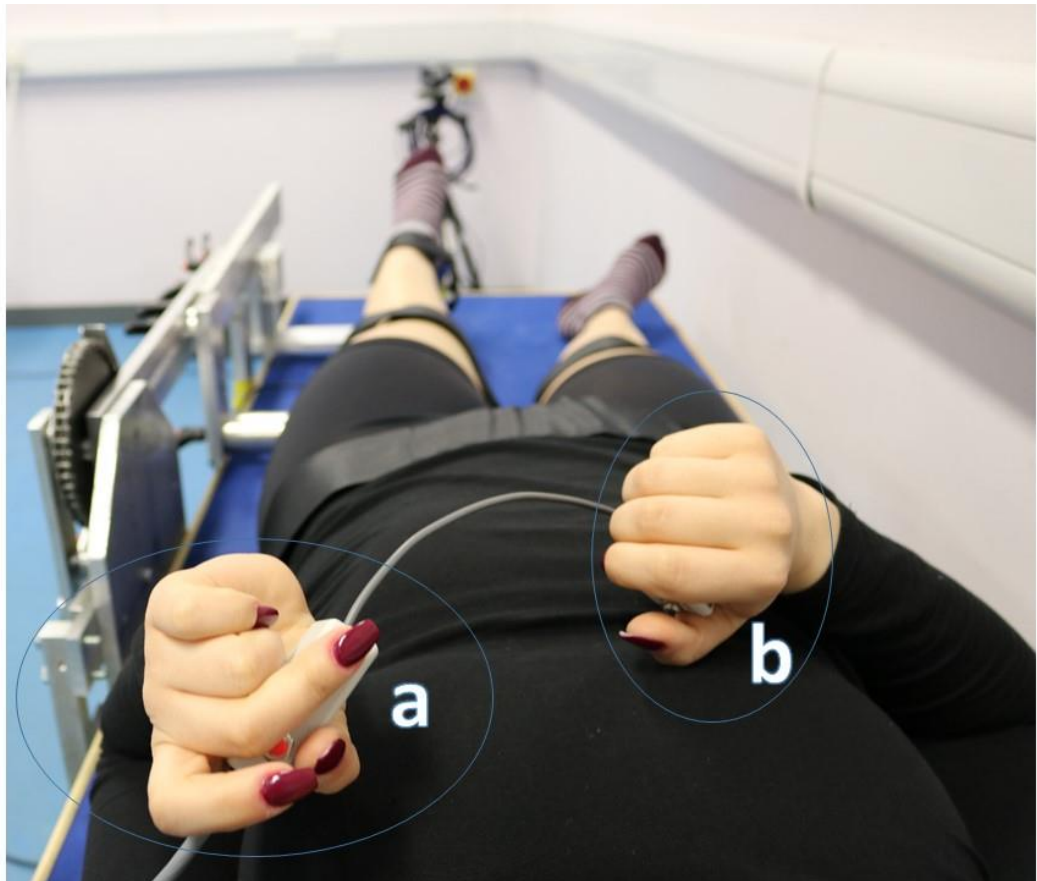

Figure 15: Participant manipulating the controls: a) lever arm control b) the first sensation of stretch control (Photo: Bárbara Pessali-Marques).

Flexibility Tests were carried out twice, once for the Pre-test (before the intervention: stretching protocol) and after for the Post-test (after the intervention: stretching protocol), with each one consisting of series of six passive stretches until the maximal ROM tolerated by the participant (ROM_{Max}). At this point, the value of the acquired torque was defined as $torque_{Max}$. Participants would press the second control button ('b' in Figure 15) when they perceived the first sensation of stretch (FSS) by a feeling of tension in the hamstrings. In this way, the respective values of ROM and torque at this point were noted as FSS_{ROM} and FSS_{torque} . Participants were blindfolded to avoid any interference of the visual stimuli to their

stretch tolerance, and both, Pre- and Post-tests were performed in both lower limbs separately.

The intervention consisted of a stretching training session. Right and left limbs were randomly assigned to initiate the Pre-test. The intervention only occurred in the lower limb that was identified in the Pre-test as possessing the greater ROM, with the contralateral limb used as the control limb. The stretch protocol was composed of a passive static (PS) stretch technique with constant torque (CT) due to the likelihood of greater S_{MTU} decrease using this technique compared to the results attainable using other passive stretch techniques (Herda et al., 2011a). The CT is characterized by the maintenance of determinate torque by the time. From the ROM_{Max} obtained in the passive flexibility Pre-test, 90% of the concomitant $torque_{Max}$ value was used for the determination of the training intensity. This intensity followed Chagas et al. (2008) recommendations that higher intensities of stretch may promote greater flexibility improvement. This absolute torque was held in each stretch manoeuvre, even if that would impose a greater ROM either in the same or in the next stretch trial (Cabido et al., 2014). The stretch is considered passive static because the same torque is maintained from the beginning to the end of the stretch. Four stretch series were executed at a rate of 30-seconds each. Participants would adjust the torque, when necessary, according to real-time visual computer screen feedback. According to Ryan et al. (2012), this protocol showed an increase in the ROM_{Max} up to the three series of stretch, with no significant difference in the accommodation in the tissue between the third and fourth stretch series. In addition, the CT technique was found to show a greater increase in the ROM_{Max} and decrease in the stiffness than the AC (Cabido et al., 2014, Yeh et al., 2007, Herda et al., 2014). The recovery time between series was approximately 20 seconds, this being the duration necessary to prepare the equipment for the next measurement (i.e. to save the recorded files and prepare the new ones to be recorded). The total time of stretching was 120 seconds and the stretch speed $5^\circ/s$ (Blackburn et al., 2004). The dependent variables included ROM_{Max} , $torque_{Max}$, FSS_{ROM} , FSS_{torque} , energy and S_{MTU} as defined in the literature review.

For the control limb, between the Pre- and Post-tests participants remained lying supine in the anatomical position for a period equal to that spent for stretching of the test limb (120

seconds). The validity (reliability and accuracy) of the equipment will be presented in Chapter 1, which details the equipment development.

3.3.6 3-D motion analysis

A 3-D motion analysis system (Vicon, Oxford Metrics, LA, USA) was used for the kinetics (Vicon was synchronised to the AMTI force platforms) and kinematics analysis assessing movement angles and angular velocity. 14 cameras Vicon MX 3-D operating at 100Hz, were used for the jump tests; the program 2.6 Nexus Motion Capture (Oxford Metrics, LA, USA) was used for data acquisition. A quintic spline filter based on code written by Herman Woltring was applied to the real marker trajectory data before the modelling stage. No further explicit filtering of the data occurs during the modelling stage. The cameras were positioned around the force platforms (AMTI Watertown, MA, USA) generating a motion capture volume to be analysed, this way, all the reflexive markers in the strategic anatomical points were visible for at least two cameras concurrently during all the jump trials (Figure 17 'e').

16 retro-reflective markers (14mm) were placed in anatomical points of the lower limb previously identified and marked with a pen, therefore ensuring markers would be placed at the same point in case of losing a marker during the movements (see Figure 16). The markers were placed at bony and anatomical landmarks in accordance with the Universal Laser System (ULS) user guideline (Limited, 2010). This set of markers defined the three-dimensional kinematics and kinetics of the pelvis, thighs, shanks, and feet of both lower limbs (Figure 17).

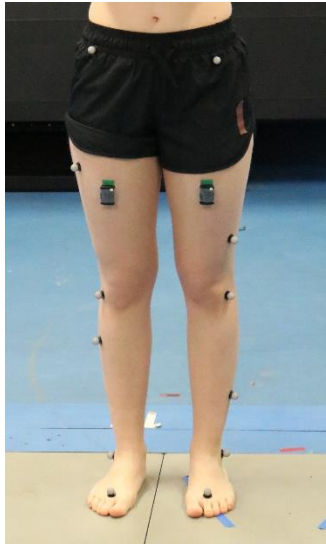
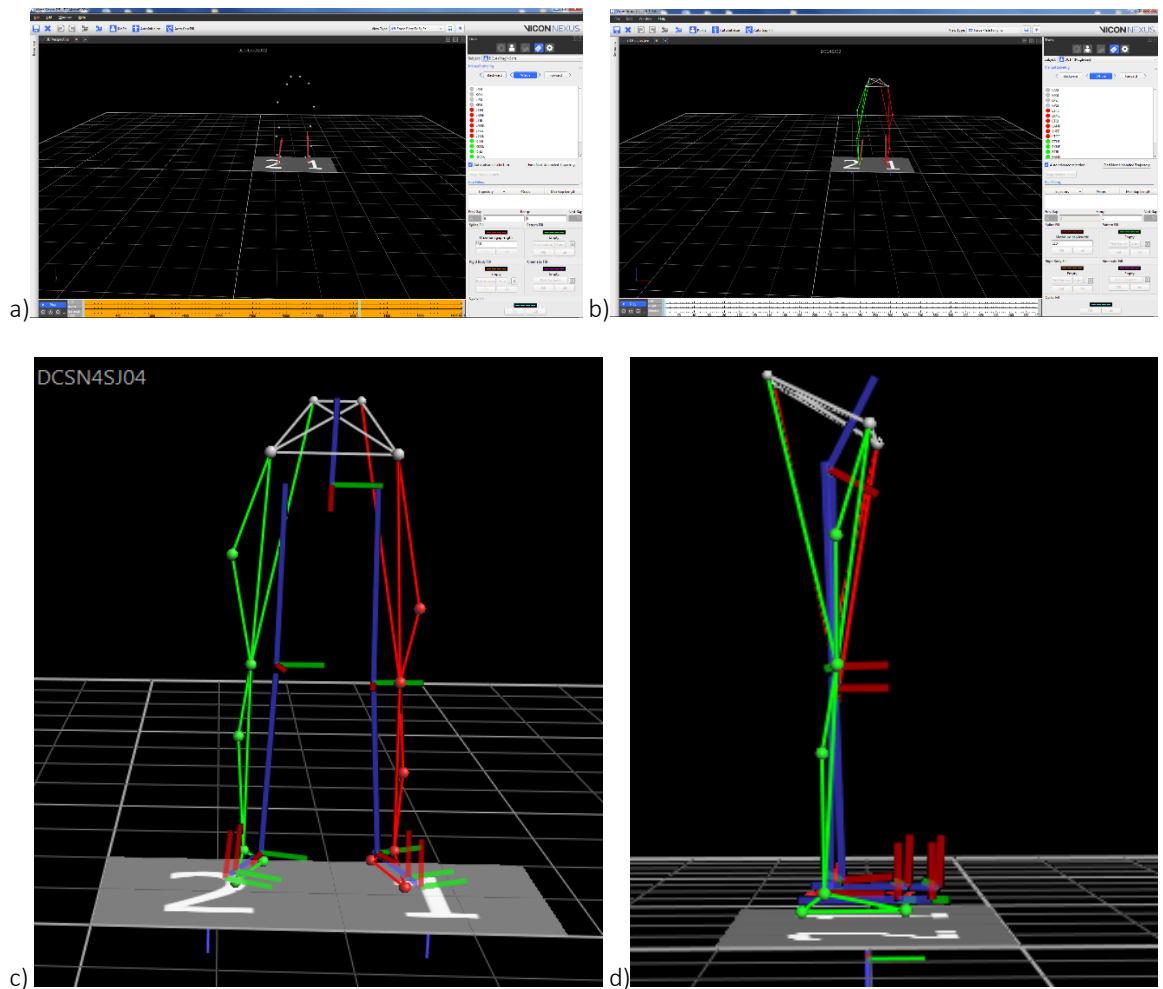
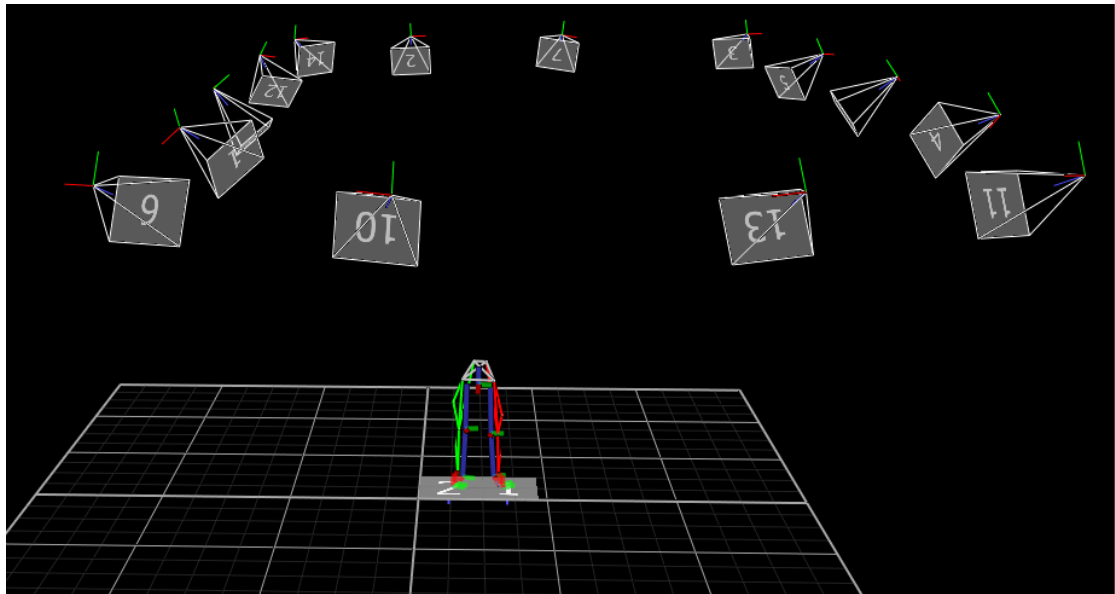

Figure 16: Reflective markers positioned (Photo: Bárbara Pessali-Marques). Reflective markers are on the left and right anterior and posterior superior iliac processes, left and right lateral femoral condyles, lateral malleoli, lateral mid-thighs, lateral mid shank, heels and second metatarsal heads.





e) Figure 17: a Reconstructed model for the 3D-analysis. a) Participant marks on the anatomical points of the lower limbs. b) Pipeline reconstruction of the lower limb bones and segments. c) Anterior and d) Lateral view with the movement axis. e) 3D infra-red cameras positioning. Note: images recorded during tests of the current thesis.

The pelvis segment coordinate system is defined by the right and left anterior superior iliac spine (ASIS) markers, since they determine the origin of the coronal orientation of the pelvis, and by the right and left posterior superior iliac spine (PSIS) markers, which determine the anterior tilt of the pelvis. Therefore, the position of the hip joint centre in the pelvis (Figure 18 and d) is calculated using the pelvis size and length (as scaling factors) and the Newington – Gage model (Limited, 2010).

The thigh and knee markers are used to calculate the knee joint centre; therefore, the femur origin is taken from the X-axis obtained from the knee joint centre to the hip joint centre, further, the remaining knee axis may be calculated. The ankle joint centre is obtained similarly to the knee joint centre, using the knee joint centre, the shank marker and the ankle marker. Finally, the foot segment is constructed using the toe and heel markers.

After all the segments and joint centres are calculated the output angles are obtained from the YXZ Cardan angles derived by comparing the relative orientation of two following segments (Limited, 2010).

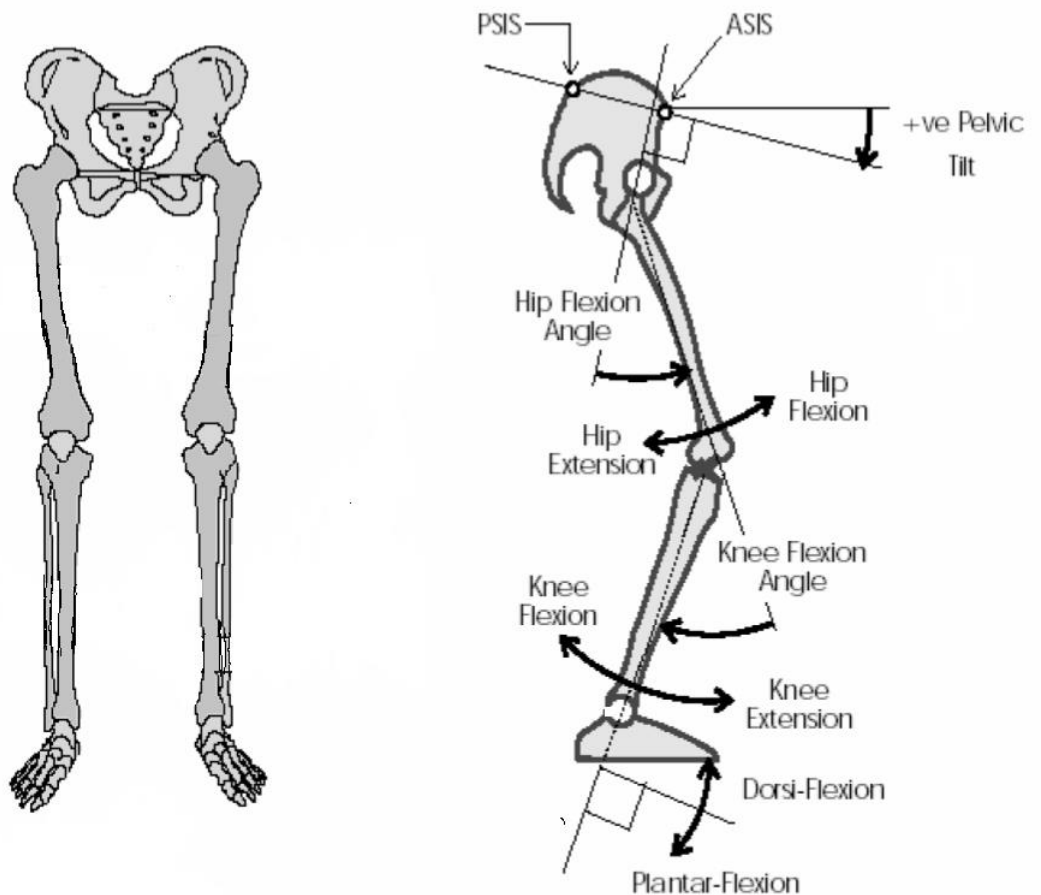

Figure 18: Kinematic variable definition - Hip Flexion/Extension: Hip flexion is calculated about an axis to parallel to the pelvic transverse axis which passes through the hip joint centre. The sagittal thigh axis is projected onto the plane perpendicular to the hip flexion axis. Hip flexion is then the angle between the projected sagittal thigh axis and the sagittal pelvic axis. A positive (Flexion) angle value corresponds to the situation in which the knee is in front of the body; Knee Flexion/Extension: The sagittal shank axis is projected into the plane perpendicular to the knee flexion axis. Knee Flexion is the angle in that plane between this projection and the sagittal thigh axis. The sign is such that a positive angle corresponds to a flexed knee; Ankle Dorsi/Plantar Flexion: The foot vector is projected into the foot sagittal plane. The angle between the foot vector and the sagittal axis of the shank is the Foot Dorsi/Plantar Flexion. A positive number corresponds to dorsiflexion. Picture modified from (Unknown, 2010).

3.3.7 Force platform and vertical jump tests

A force platform is a metal plate that varies in size with piezoelectric or strain gauge transducers at each corner to give an electrical output that is proportional to the force on the plate. It measures the force exerted on it by the subject according to Newton's third law of motion (Linthorne, 2001). Two synchronized force platforms (AMTI Watertown, MA, USA) mounted side by side were used to quantify the kinetic variation of ground reaction force (GRF) of the squat and countermovement jump in the Pre- and Post-test. The acquisition frequency was 1000 Hz (Menzel et al., 2013a) and the software 2.6 Nexus Motion Capture (Oxford Metrics, LA, USA) was used for the acquisition of the data.

Three CMJs were completed with a 20-second interval between them. The participant stood upon the force plates (one foot on each plate), standing in the vertical position with feet parallel and shoulder-width apart, hands on the hips and looking forward. An eccentric phase in a self-selected flexion angle of ankle, knee and hip was performed immediately before jumping as high as possible. There was no pause between the eccentric and the concentric phase (Padulo et al., 2013, Menzel et al., 2013b, McErlain-Naylor et al., 2014).

SJs were also performed on the force platforms (AMTI Watertown, MA, USA) with one foot on each plate. Participants were similarly positioned as at the bottom of the CMJ with both hip and knee in a self-selected angle. Participants held in this position for three seconds, after which, they jumped upwards without any eccentric movement. In this procedure, the participant was asked to jump as high as possible with no downward phase, having just a concentric phase (Padulo et al., 2013, Menzel et al., 2013a, Menzel et al., 2013b, McErlain-Naylor et al., 2014). Three SJ were completed with a 20-second interval between the jumps.

From the three trials of CMJ and three trials of SJ, the highest jump of each was used for further analysis. The $force_{peak}$ and impulse were obtained from each of the force plates and total $force_{peak}$, total impulse, jump height and take-off velocity calculated using the sum of both force plates.

3.3.8 Electromyography

Electromyography (EMG) is a physiologic signal that measures electrical currents resultant trace from many action potentials generated in muscles during contractions and allows the determination of the neuromuscular activity (Reaz et al., 2006). Electrodes placed over the muscle belly (most commonly skin surface electrodes) capture the EMG signal that is amplified and filtered to reduce noise (electrical signals that are not part of the desired EMG signal) (Reaz et al., 2006) before being sampled by a computer.

EMGs from the semitendinosus and rectus femoris were measured by surface electrodes (Trigno, Delsys, Natick, Massachusetts, USA) using a frequency of acquisition of 1000Hz and amplification of x1000. Prior to positioning the electrodes, the skin was shaved and cleaned with alcohol wipes (BlueSensor M, Ambu, Copenhagen, Denmark). Semitendinosus

electrodes positioning was performed with participant prone, the ischial tuberosity and the epicondyle medial of the femur were identified and a line was traced between these points (Rodacki et al., 2001). The electrode was positioned at the medial point of this line (Mchugh et al., 1992). For the rectus femoris participants laid supine, the tendon of the rectus femoris and the patella were identified, and a line was traced between these points, the electrodes were also positioned at the medial point of this line. The examiner immobilized the participant's limb as straight as achievable, so that isometric muscle contractions of hip flexion and hip extension could be performed, thus enabling a signal check (Figure 19).



Figure 19: a) EMG electrodes on the semitendinosus b) EMG electrodes on the rectus femoris (Photo: Bárbara Pessali-Marques).

The raw EMG does not offer useful information but requires signal-processing methods to quantify (Reaz et al., 2006). Data processing began with rectification following the removal of any zero offsets (Figure 20) and then converting into root mean square (RMS) value with a window of 0.1 s and overlap of 0.08 s. Figure 21 shows the comparison of different window and overlap lengths tested to establish the procedure. Thus, the rate of resting value contraction (%RVC) of muscle activation was used to normalize the dynamic contraction recorded. The standardization of each participant's EMG amplitude with the corresponding resting value is important to allow comparisons of the curves between participants and sessions. The resting value was chosen due to immediate measurement when participants were prepared to perform the jump but before any movement. Although the maximal voluntary isometric contraction is the most common method to normalize the EMG (Yang and Winter, 1983), there is no consensus regarding the best method. Due to time limitation, the collection of the EMG at maximal voluntary contraction was not performed. Moreover, the resting EMG appeared to be repeatable between individuals and muscles (Halaki and

Ginn, 2012) and able to reduce interindividual variability in relation to un-normalized EMGs (Burden, 2010).

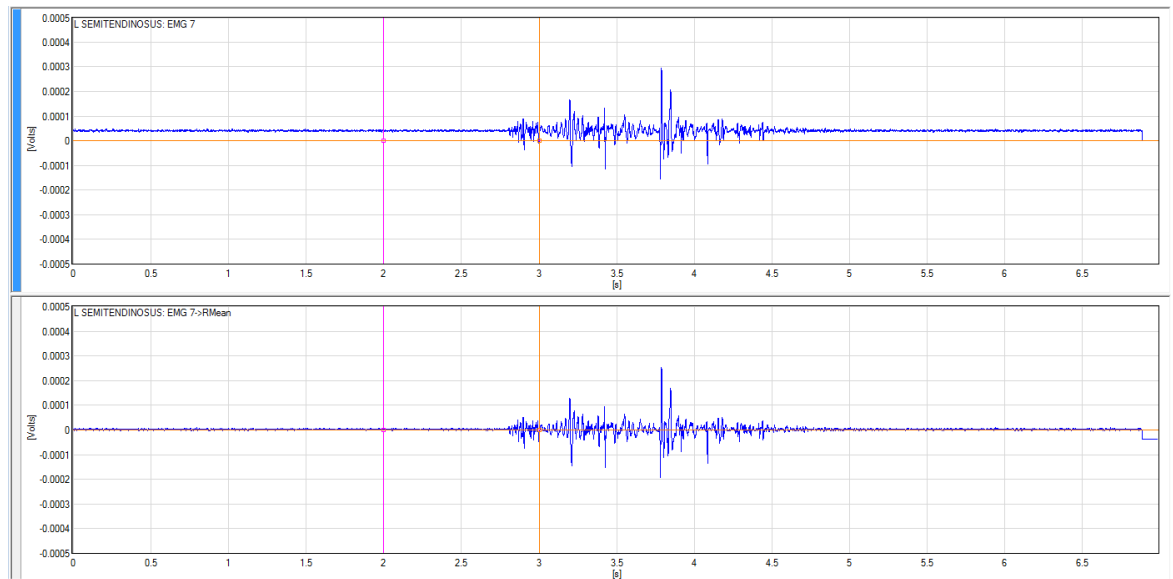

Figure 20: Electromyographic zero offset removal. Note: image recorded during tests of the current thesis.

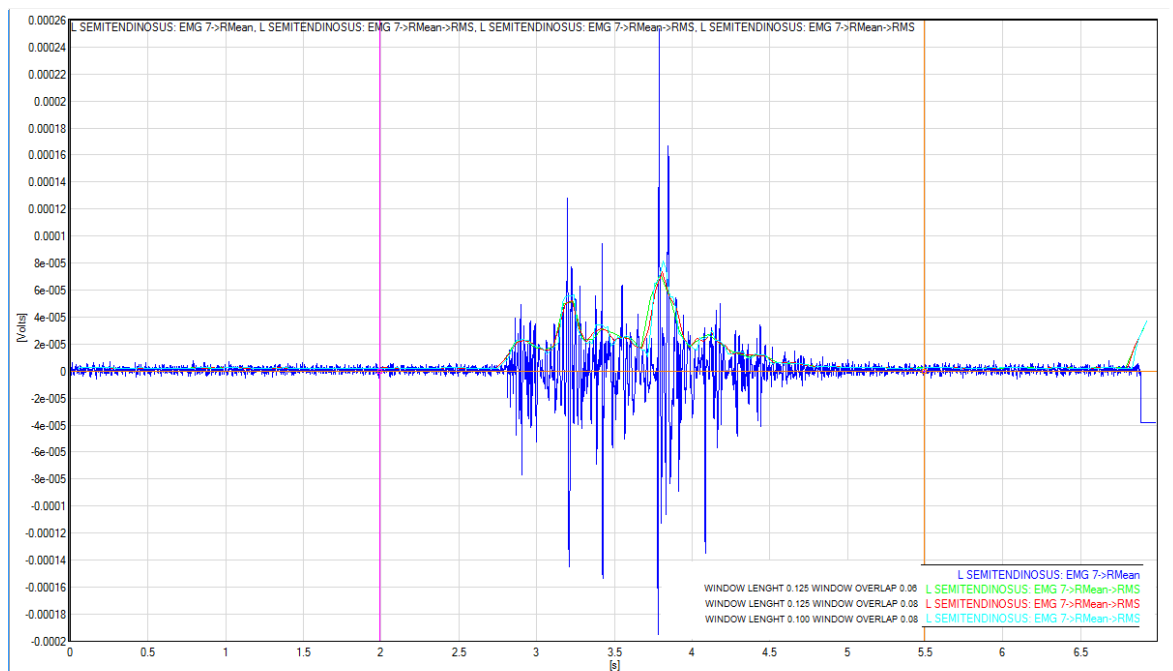

Figure 21: Root mean square with different window length and window overlap times. Note: image recorded during tests of the current thesis.

EMG from the highest jump for each participant was analysed during the time between the start of the movement (decrease of the weight) and take-off (when the toes lose contact with the floor). For the flexibility analyses, the EMG threshold was used to confirm the

passive nature of the stretching, as this helped identify any muscle activity during the passive hip flexion. Following processing, the signal exceeding the resting baseline value plus twice the standard deviation was used as the EMG threshold (Cançado, 2014, Peixoto et al., 2015).

3.3.9 Ice Water Test

The Ice Water Test (IWT) was performed to characterise participants' sensitivity to pain. Two water containers sufficiently deep to allow the immersion of the dominant forearm up to the elbow were used. One general-purpose Liquid-In-Glass Thermometer ranging from -10 to 110° C, 50mm immersion (B60300-0000, H-B Instrument, Loughborough, Leicestershire UK) in each container was used to ensure the temperature remained at 35-39° Celsius (body temperature) or -3 to 0° Celsius (cold sensation). The IWT has been widely used in cardiovascular, stress and pain research for decades. This protocol followed guidelines on the IWT described elsewhere (von Baeyer et al., 2005, Silverthorn and Michael, 2013), with the IWT being deemed as a reliable task to assess pain tolerance, provided that the initial hand temperature is recorded, and the cold temperature maintained to compare against (Mitchell et al., 2004).

To standardise initial conditions and similar body temperature prior to the IWT for all participants, each participant's dominant arm (up to the elbow) was immersed in a 35-39° Celsius (body temperature) for 120 seconds; then the dominant arm was immersed in a -3 to 0° Celsius for a maximum duration of 120 seconds. In addition, qualitative (affective and sensory) aspects of the potential pain experience during cold and warm water immersion were assessed every 15 seconds using the Visual Analogue Scale (VAS) (Appendix G). Participants were instructed to hold as long as possible with the arm under the water. They were also instructed to take their arms off whenever they felt they could no longer tolerate the cold. Participants were not made aware that the cut-off threshold for the test was at the 120 seconds point. The researcher, using a digital chronometer, recorded the time of withdrawal.

3.3.10 Visual Analogue Scale (VAS)

The VAS is a numeric visual 10-point scale and has previously been used during the Ice Water Test and during a stretching intervention. The scale was shown to participants each 15-

second that they could hold the arm in the ice to obtain the representative number of the discomfort they were feeling from zero to 10, with zero being no pain and 10 the maximal pain they have ever felt. The scale was also presented in the Intervention as soon as the stretching intensity was reached and again in the last second of the static phase (1- and 30-seconds of the constant torque stretching respectively).

3.3.11 Questionnaires

The pain assessment questionnaires were answered in every session, randomly assorted to be filled either before or after the IWT. The ParQ was answered only once to characterise the participants and to help uncover any potential health risks associated with exercise.

3.3.11.1 The Self-Estimated Functional Inability because of Pain (SEFIP)

The SEFIP was especially designed for dancers (Yurt et al., 2013, Miletic, 2007) and used in injury and pain research. This self-report questionnaire (Appendix H) combining a body map (participants must localise the pain) and 16 body areas rated on a 5-point Lickert scale; was deemed to also be helpful to assess menstruations-related (painful) symptoms.

3.3.11.2 Pain Anxiety Symptom Scale (PASS) Short Form 20

The short version of the PASS (McCracken and Dhingra, 2002) is a 20 item self-report questionnaire, validated and used among clinical and healthy populations (McCracken, 2013). Given the literature on psychological factors involved in pain perception (Villemure and Bushnell, 2002) (Nahman-Averbuch et al., 2016) the PASS 20 was chosen because of its easiness to understand, its rapidity to fill in and the relevance of the four subscales. The four subscales refer to well-studied dimensions in pain research:

- Cognitive anxiety: cognitions related to pain anticipation
- Escape and Avoidance: withdrawal behaviours related to actual pain or the anticipation of pain
- Fear: actual fearful thoughts (often intrusive) related to the experience or anticipation of pain
- Physiological Anxiety: bodily reaction when experiencing or anticipating pain

3.3.11.3 The Physical Activity Readiness Questionnaire (PAR-Q)

The Physical Activity Readiness Questionnaire is a self-screening tool to determine the safety or possible risk of exercising for an individual based on their health history, and current symptoms and risk factors according to the ACSM Standards and Guidelines for Health and Fitness Facilities. All the questions were designed to help uncover any potential health risks associated with exercise. The PAR-Q helped to identify any participant for whom physical activity may be inappropriate or those who should have medical advice concerning the type of activity most suitable for them. It was a safety procedure recommended for any type of exercise and was also used to characterise the groups in this research.

3.3.12 Anthropometric measurement and body composition

Anthropometric measurements were performed every session to compare participants' body dimensions between the groups and across menstrual cycle phases. A bioelectrical impedance analysis (BIA) (BodyStat 500, Bodystat Ltd, Isle of Man, Uk), which provides a simple method to assess body composition, was used to measure the body fat and lean percentage and weight, body water percentage and total body water, basal metabolic rate and body mass index. These measurements were taken at every data collection session.

3.3.13 Familiarisation

Independent of how many sessions each participant was required to participate, the first session was always the familiarisation. During the familiarization, participants were informed about all the procedures and protocols, signed the consent form followed by training for the tests. Participants received equipment instructions for the passive flexibility test and undertook as many trials as they needed until they felt comfortable and safe with the tests. The familiarisation was completed when the ROM and torque curves were consistent; with no peak contraction and no peak EMG activity during the stretching. For the intervention, participants learned how to increase the ROM to maintain the torque constant in case any accommodation occurred.

The jump familiarisation was completed via eight randomized vertical jumps of each technique (countermovement – CMJ and squat jump - SJ); one minute of the interval was given and eight more jumps were undertaken. Participants were considered familiarised when the performance for the first series of jumps was statistically equivalent to the second

(Claudino et al., 2013). Differently of the tests, jump familiarisation was performed on top of a jump mat due to the immediate height results (Rogan et al., 2015).

Chapter 1:

Reliability of hip flexion Flexibility Test Equipment

*"Em algum lugar, alguma coisa incrível está esperando
para ser descoberta."*

Carl Sagan

*"Somewhere, something incredible is waiting
to be known"*

Carl Sagan

4.1 Introduction

Flexibility is a physical capacity usually represented by the range of motion (ROM), which is the overall degree of movement about a joint (Magnusson et al., 1997, Di Alencar and Matias, 2010). There is a lack of consensus in the literature concerning whether training this capability is important for improving performance and/or decreasing injury risks (Gannon and Bird, 1999, Klemp et al., 1984). Studies have proposed that flexibility requirement is sport specific (Harvey, 1998, Chandler et al., 1990), yet the amount necessary for each sport modality is not clearly established. Given that flexibility is important for the practice of dance (Prati and Prati, 2006, Scheper et al., 2012, Karloh et al., 2010, Tajet-Foxell and Rose, 1995), other factors may be queried including: 1) the necessary flexibility level required in dance to decrease injury risk, 2) whether flexibility training will improve or decrease overall dancers' performance, 3) if dancers would show similar response to the same stretching protocol as non-dancers in terms of relative changes in the MTU, 4) the best protocol to improve flexibility in dancers.

Aiming to solve some of these concerns, studies have compared dancers' and other populations response to different training protocols (Wójcik and Siatkowski, 2014, Apostolopoulos et al., 2015a, Apostolopoulos et al., 2015b, Wyon et al., 2009, Smith et al., 2013, Ambegaonkar et al., 2011, Bauer et al., 2015, Bennell et al., 1999, Koceja et al., 1991, Lima et al., 2016, Nielsen et al., 1993, Rubini et al., 2011, Scheper et al., 2012, Pessali-Marques, 2015). Although studies comparing the influence of flexibility training in dancers (Wyon et al., 2009, Smith et al., 2013) are found, the ROM is commonly the only variable analysed to indicate an improvement in flexibility. Therefore, the full comprehension of the MTU modifications after training remains unknown. Only one study was found relating to the biomechanical and sensory properties of the MTU during a stretch in dancers (Pessali-Marques, 2015), however, due to limitations in the equipment the authors conceded that maximal ROM was not reached in their study.

A possible reason for the lack of research evaluating S_{MTU} , energy, creep or stress-relaxation, hysteresis, torque, ROM and the first sensation of stretch (necessary variables to explain the biomechanical and sensory properties of the MTU under stretching) may be due to the scarcity of equipment able to provide such measurements and/or demonstrate accuracy and

concurrent validity. Pessali-Marques (2016) compared different equipment used in flexibility research and found, to the authors' knowledge, only one device able to measure all the aforementioned variables in addition to a great ROM; thus making it possible to assess very flexible populations, such as dancers.

The first version of the Passive Flexibility Test Equipment (FTE) was developed in the Biomechanics Laboratory of the Excellence Centre in Sports at the Physical Education, Physiotherapy and Occupational Therapy of the Federal University of Minas Gerais, Belo Horizonte, Brazil (Pessali-Marques, 2016). Although this equipment is able to measure flexibility in a multidimensional approach reaching great ROM, two limitations were raised during the tests: 1) the equipment lever is manually moved by the examiner, who continuously adjusts the speed according to instantaneous feedback provided by the computer. Therefore, whilst the examiner is able to maintain the speed below 5 degrees/s, the speed is not constant. 2) Participants are positioned with the hips flexed at 160 degrees, thereafter, knee extension is performed to stretch the hamstrings (Figure 22). Even though the equipment could have allowed the participant to be positioned at a greater angle than 160 degrees of hip flexion, this was the maximal angle at which both groups, dancers and non-dancers' position, could be standardised. A greater angle made it difficult for the non-dancers to be positioned in the equipment and a smaller angle facilitated full knee extension by the dancers. This angle, however, was also not enough to impede the full knee extension for the dancers (Pessali-Marques, 2015) after the training protocol.



Figure 22: Participants positioned with the hips flexed at 160 degrees. Thereafter, the knee extension is performed to stretch the hamstrings. From Pessali-Marques (2015).

An improvement included the addition of an engine to control the lever and this was again performed by Bárbara Pessali-Marques and Alexandre Barros at Bastidores - Dance, Research & Training, Belo Horizonte, Brazil (Figure 23). Whilst the engine solved the lever's constant speed issue, the maximal hip flexion angle remained lower than required to assess highly flexible participants. Thenceforth, the aim of the current study was further development (third version), of the comprehensive ROM assessment apparatus and assess the reliability of the measurements.

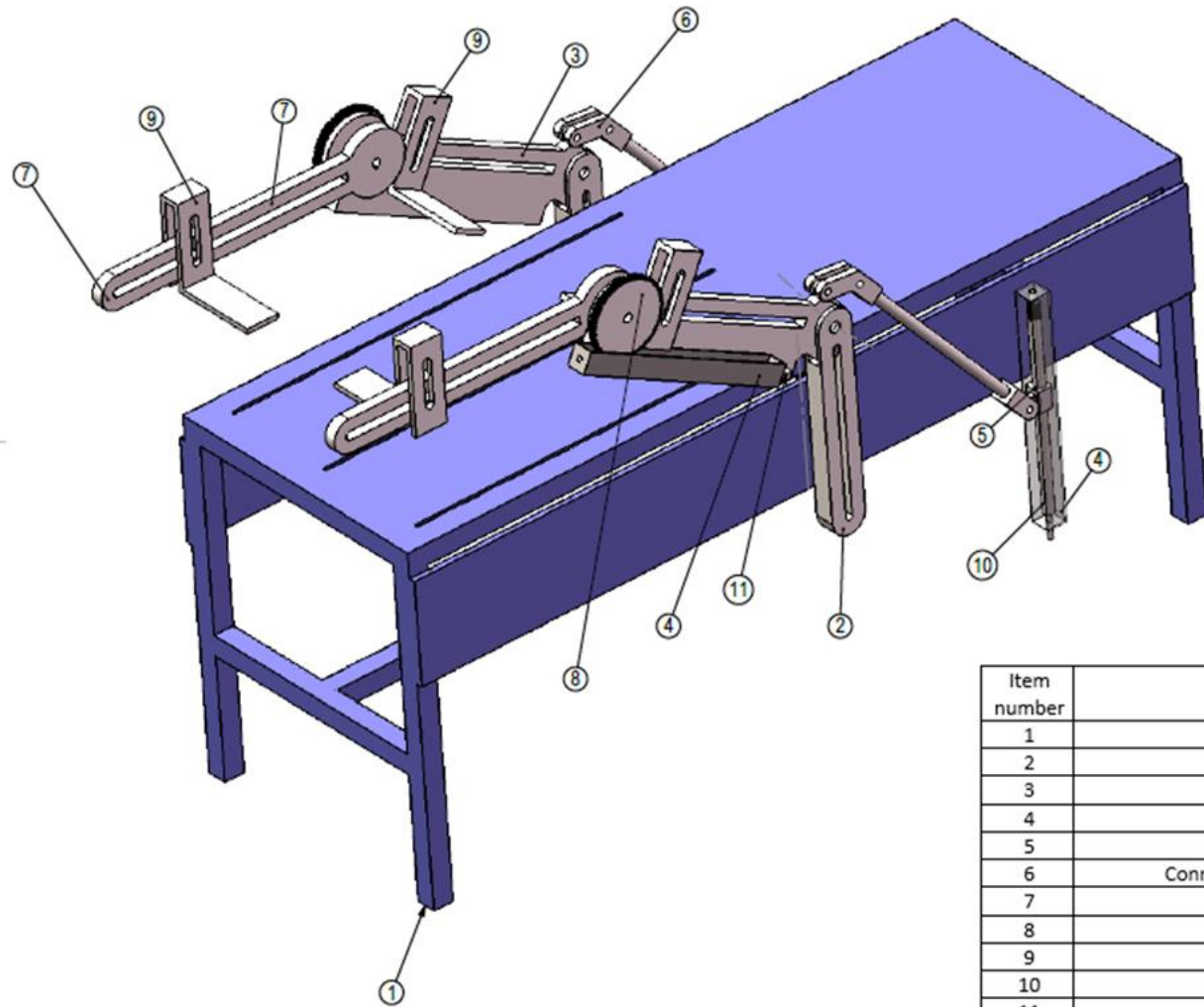

Item number	Reference	Quantity
1	Table	1
2	Hip height adjustment	2
3	Thigh lever	2
4	Thigh and ankle rotation axis protector	4
5	Traction axis	2
6	Connection lever between the traction axis and the hip axis	2
7	Lower leg lever	2
8	Knee rotational axis	2
9	Hip and ankle support	4
10	Tight axis rotation traction lever	2
11	Knee axis rotation traction lever	2

BB Concept Bárbara Pessali-Marques

letec
Ferramentaria Design Alexandre Barros

Figure 23: Second version of the Flexibility Test Equipment (Bastidores – Dance, Research and Training archive).

4.2 Methods

4.2.1 Participants

Seventeen undergraduate dance students comprised the study (mean [SD]: age; 21 [7] years, body mass; 65.83 [2.80] kg, height; 1.61 [0.03] m, body fat; 29.6 [2.05] %). Ethics, inclusion and exclusion criteria are described in the Overall Methods⁸.

4.2.2 Procedures

To assess the reliability of the FTE measurements, participants underwent two data collection sessions: i) familiarisation session (day 1), ii) test session (day 2) (Figure 24).

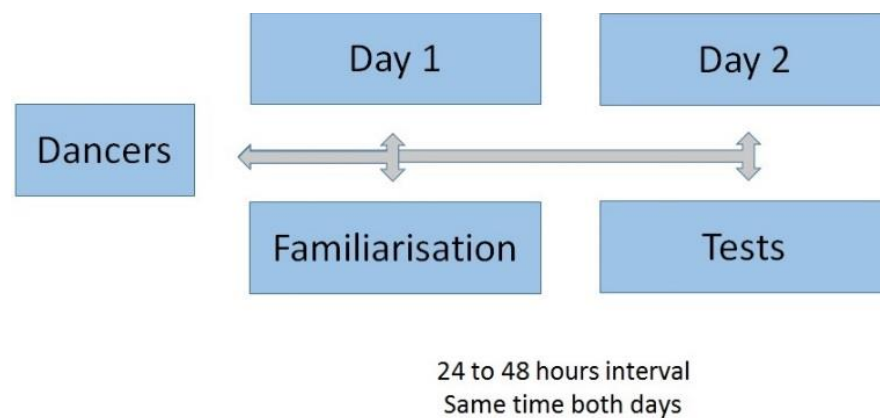

Figure 24: Illustration of the experimental procedures.

Familiarization⁹ for the flexibility tests was performed in the first session and the Tests¹⁰ (Pre- and Post-test – Figure 30) were performed on the second session with 24 to 48-hour interval between the sessions. All sessions were performed at the Muscle Function Laboratory at Manchester Metropolitan University. The Pre-test consisted of six trials of passive hip flexion to the maximal ROM tolerated (ROM_{Max}). The torque recorded at ROM_{Max} was defined as $Torque_{Max}$, and the ROM and torque at the moment in which the FSS was signalised were defined as FSS_{ROM} and FSS_{torque} respectively.

Following the Pre-test, participants remained lied supine in the anatomical position, for the same period that would have been spent to perform a stretch protocol consisted of four series of 30-seconds each (120 seconds). Finally, the Post-test, following the same protocol

⁸ Vide Overall Methods section 3.1 and 3.2 page 53

⁹ Vide Overall Methods section 3.3.13 page 78

¹⁰ Vide Overall Methods section 3.3.5 pages 66

as in the Pre-test, was performed (Figure 25). From the six trials assessed either during the Pre- or Post-test, the average of all six trials, the average of the first three only and the last three only were used for statistical analysis.

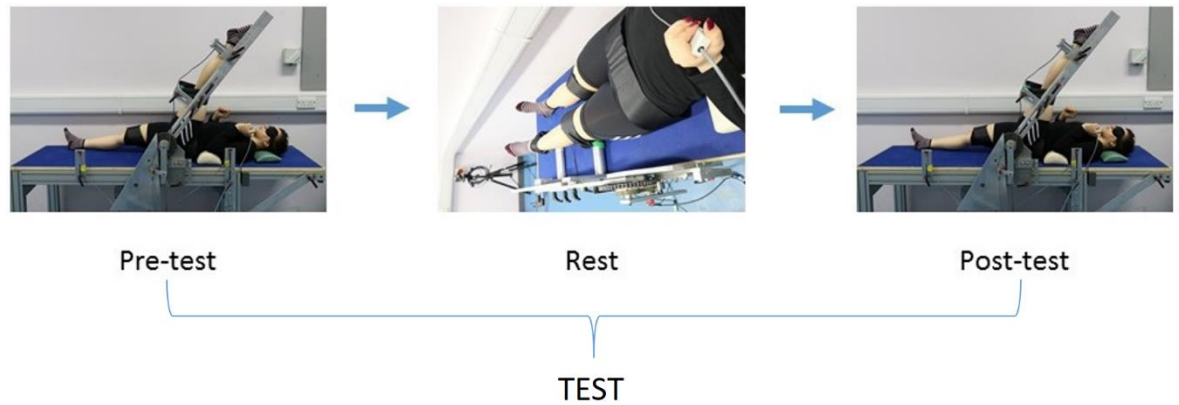

Figure 25: Illustration of the experimental design for the control group (Photos: Bárbara Pessali-Marques).

During the passive hip flexion, the electromyography (EMG) activity of the semitendinosus muscle was monitored in accordance with previous authors' recommendations Mchugh et al. (1992) in order to confirm that the stretch was passive.

4.3 Statistical analyses

The reliability of the ROM_{Max} , $Torque_{Max}$, FSS_{ROM} and FSS_{torque} were assessed via intraclass correlation coefficients (ICC3, k) and the standard error of the measurements (SEM). SEM was normalised by the average values of variables, resulting in a percentage of SEM (SEM%) (Weir et al., 2005). ICC values were classified as weak (<0.4), moderate (0.4 to 0.59), good (0.6 to 0.74) and excellent (0.75 to 1.0) (Cicchetti, 1994).

4.4 Results

4.4.1 Flexibility Test Equipment development

The FTE (Figure 27) was developed to measure passive torque, passive ROM and First Sensation of Stretch (FSS). Therefore, S_{MTU} , creep or stress-relaxation, hysteresis and energy can be calculated as described in equation 2¹¹ and methods section¹². It can also be used to

¹¹ Vide page 10

¹² Vide Table 8 pages 56-58

test and to train the flexibility of the hamstrings and to analyse the MTU response to intervention through different passive stretch techniques, such as CT and AC. The equipment was designed to allow a separate measurement of the right and left lower limbs.

Participants were positioned supine on the table with the trochanter aligned to the rotation axis of the lever and the ankle held in support adjusted 2 cm proximal from the lateral malleolus. The ankle support was designed in a 'U' shape (Figure 27 '2') to minimise hip external rotation. A load cell (Figure 27 '3') was coupled underneath the support to measure the MTU's resistance force against the stretch. In the initial position, the hip is considered 0° of hip flexion with the possibility of ranging up to 180°; the knee is maintained in 180° of the extension during the whole stretch intervention. Additional support (Figure 27 '5') was positioned behind the thigh to avoid hyperextension of the knee. All the supports were individually adjusted according to each participant's limb lengths and once the position is settled it was recorded to be reproduced in further testing sessions. Straps around the ankle, distal third of the thigh and anterior superior iliac spine (Figure 27 '11'), fixed the participant in the testing position. In addition, the thigh of the contralateral limb was strapped to the table and cushions under the lower back and neck (Figure 27 '12') were used both for comfort and to minimise spine compensatory movements.

Participants used two buttons (one to ascend and the other to descend the lever), to control the equipment (Figure 27 '1'). The lever angle speed, operated by a motor (Parvalux motor and right angle gearbox model BH11 8PU PM3d LWS63690/01J, Parvalux, Bournemouth, United Kingdom) was maintained at a constant 5°/s speed (Figure 27 '10'). This speed was chosen due to previous recommendations for passive movement assessment (Blackburn et al., 2004), given that it elicits no muscle reflex responses that might affect the resistance to stretch should be expected. For Health & Safety reasons the lever stops immediately if the button is not continuously pressed. In addition, the researcher could stop the equipment, if necessary, using an emergency button. A secondary button was also operated by participants, which marked when they first perceived the first sensation of stretch - FSS (i.e. tension in the hamstrings) (Figure 27 '6').

The ROM was recorded by a potentiometer (TT Electronics ABW1 5K +/- 10% Rapid Electronics part no 51-7053, Abercynon, United Kingdom) located in the rotation axis of the lever (Figure 27 '7'). To calibrate it, a digital goniometer (precision 0.5°, GAM 220 MF, Bosch, Leinfelden-Echterdingen, Germany) and the DasyLab program 11.0 (Dasytec Daten System Technik GmbH, Ludwigsburg, Germany) was used (Figure 27 '9'). The potentiometer voltage was taken with the lever at 0° and 180°. The delta value from the ROM was divided by voltage delta to find 'x' from the linear regression equation ($f(x) = ax + b$) that described the potentiometer's linear behaviour (Figure 26). Accordingly, the lever was positioned in other known angles to verify its consistency. A degree of error below 1° was considered acceptable.

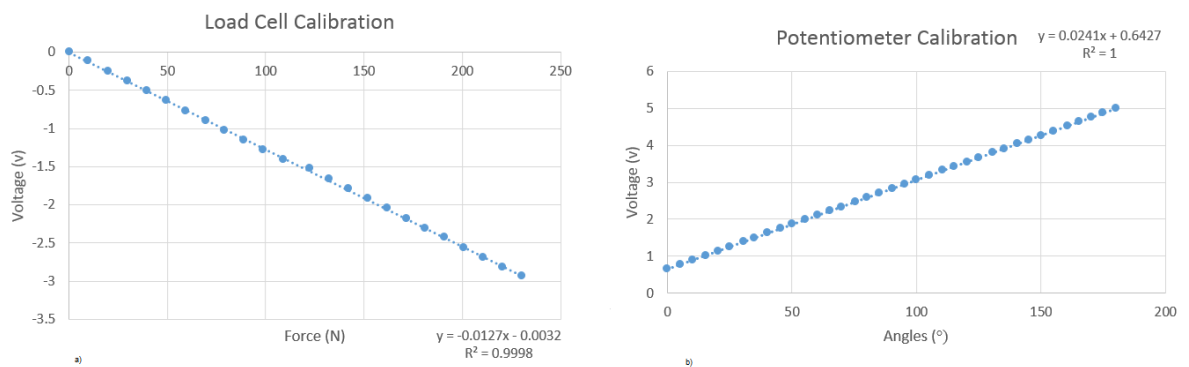

Figure 26: Linearity of a) Load cell and b) potentiometer. Note: data from tests of the current thesis.

The load cell (CS 15 V, Líder Balanças, Araçatuba, SP, Brazil) and an amplifier (Strain Gauge Transducer SMOWO, RW-ST01, Shanghai Tianhe Automation Instrumentation Co, Shanghai, China) (Figure 27 '3' and '4' respectively) measured the hamstrings' resistance force against the stretching. This force, multiplied by the leg length, provided the passive torque. To calibrate, the lever was positioned parallel to the floor and the voltage of the load cell (positioned at 1 m from the lever rotation axis to allow the torque measurements) without and with a 15 kg weight was taken. The delta value from torque was divided by voltage delta to find 'x' from the linear regression equation ($f(x) = ax + b$) that describes the load cell linear behaviour. Similar to the procedure for the calibration of the potentiometer, other known masses were positioned above the load cell to check the calibration. An error below 0.1 N was deemed acceptable.

The DasyLab program (v11.0 Dasytec Daten System Technik GmbH, Ludwigsburg, Germany) was used for the gravity correction. Participants laid supine and the masses of the participant's limb was measured at 0° of hip flexion. From this mass and the lower limb length, the maximum gravity effect torque (MaxGET) was computed. The MaxGET, limb position, and direction of motion were used to adjust the torque values for the effects of gravity using the following Equation 5:

$$\begin{aligned} & \textit{Limb assisted by gravity reported torque} \\ & = \textit{measured torque} - (\textit{MaxGET} * \textit{sine (angle)}) \end{aligned}$$

$$\begin{aligned} & \textit{Limb resisted by gravity reported torque} \\ & = \textit{measured torque} + (\textit{MaxGET} * \textit{sine (angle)}) \end{aligned}$$

Equation 5: Gravity correction equation.

The reported torque values were used to compute the maximal torque ($\text{torque}_{\text{Max}}$), the torque in the first sensation of stretch ($\text{FSS}_{\text{torque}}$) and to calculate passive S_{MTU} .

The potentiometer, the load cell and the FSS control (aforementioned as secondary control operated by the participant) are connected to an analogue/digital converter (NI USB-6008 National Instruments, Austin, Texas, EUA), itself connected to a desktop computer (Porg ete Z30, Toshiba, Hammfelddamm, Neuss, Germany). The DasyLab program 11.0 (Dasytec Daten System Technik GmbH, Ludwigsburg, Germany) was also used for data acquisition and analysis (Figure 27).

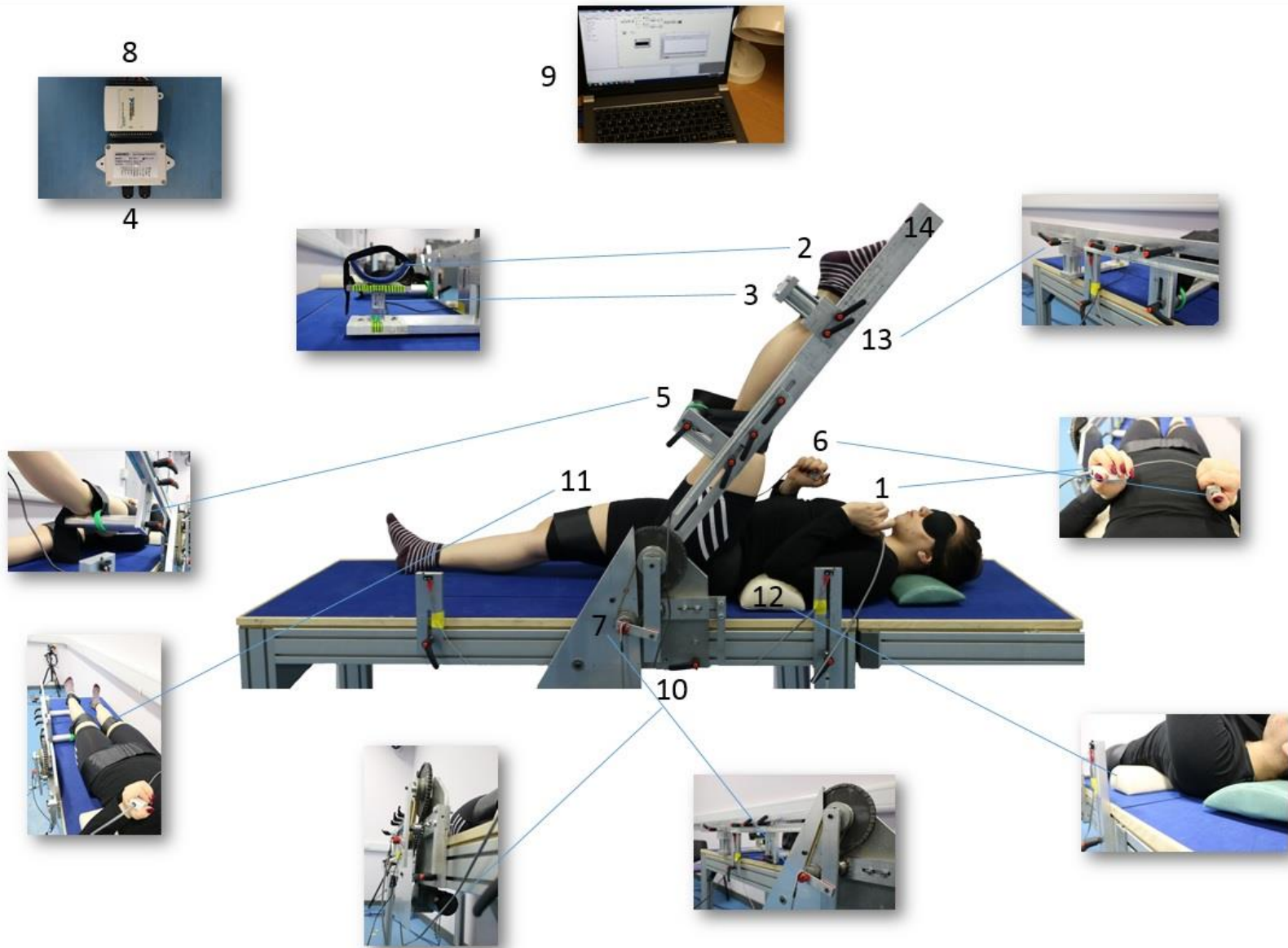

Figure 27: Push-button to control the ascend and descend movements of the lever; 2. The ankle support designed in a “U” shape to minimise hip external rotation; 3. Load cell (CS 15 V, Líder Balança, Araçatuba, SP, Brazil) to measure the MTU’s resistance force against stretch; 4. Amplifier (Strain Gauge Transducer SMOWO, RW-ST01, Shanghai Tianhe Automation Instrumentation Co, Shanghai, China); 5. Support for the thigh to avoid hyperextension of the knee; 6. Controller to signal the FSS: a tension in the hamstrings; 7. Potentiometer (TT Electronics ABW1 5K +/- 10% Rapid Electronics part no 51-7053, Abercynon, United Kingdom TT) to record the ROM; 8. Analogical/digital converter (NI USB-6008 National Instruments); 9. Computer: DasyLab program 11.0 (Dasytec Daten System Technik GmbH, Ludwigsburg, Germany); 10. Motor (Parvalux motor and right angle gearbox model BH11 8PU PM3d LWS63690/01J, Parvalux, Bournemouth, United Kingdom); 11. Straps to fix the limb 12. Cushions for the neck and lumbar areas; 13. Adjustable sections according to participant’s limb length; 14. Lever. (Photos: Bárbara Pessali-Marques).

4.4.1.1 Flexibility Test Equipment - Data acquisition and analysis

Seven worksheets were created using the DasyLab software (v11 Dasytec Daten System Technik GmbH, Ludwigsburg, Germany) for data acquisition and analyses:

- a) Calibration Worksheet
- b) Right Limb Test
- c) Left Limb Test
- d) Right Limb Training
- e) Left Limb Training
- f) Data Reading
- g) S_{MTU} and Energy Calculation

All the worksheets were developed to correct for gravity according to the aforementioned equation and to the individual mass and limb length (great trochanter until 2 cm proximal from the lateral malleolus), and to filter the signal using a 15Hz Low Pass Butterworth filter. The worksheets were synchronized with Delsys program to receive the electromyographic signal (Trigno, Delsys, Natick, Massachusetts, USA) from both the rectus femoris and semitendinosus muscles in order to start all the measurements at the same time. The Test worksheets (Right and Left Limb Test) provided the ROM_{Max} , $Torque_{Max}$, FSS_{ROM} and FSS_{torque} immediately after the acquisition. The Training worksheets (Right and Left Limb Training) provided the instantaneous feedback of the torque and ROM to control the intensity of the stretch. All the worksheets also provided graphic images of the assessed variables¹³.

¹³ Vide Appendix D page 270

The Data Reading worksheet was developed to save files to allow immediate (i.e. post-acquisition) or postponed analysis, thereby allowing flexibility in the approach to data crunching where needed. Finally, the S_{MTU} and energy worksheet calculates the variation in the ROM divided by the variation in the Torque (S_{MTU}) using the third portion of the slope in the ROM vs. torque graph (Figure 8¹⁴). The third portion is generally used due to its greatest linearity compared to the other portions of the curve (Magnusson et al., 1996a) and more reliable Peixoto et al. (2011). The energy is represented by the area under the same portion.

4.4.1.2 Flexibility Test Equipment - Tests

The torque x time and the ROM x time curves (Figure 28) were plotted with instantaneously during the flexibility tests, providing the values for ROM_{Max} , $torque_{Max}$, FSS_{ROM} and FSS_{torque} . The EMG signal of the hamstrings, synchronized with the stretch intervention, allows the analysis of any muscle activity. If the muscle activity is greater than twice the standard deviation of the rest EMG, the program automatically cuts the ROM and torque curves at that point, establishing the new values for the maximal torque and ROM.

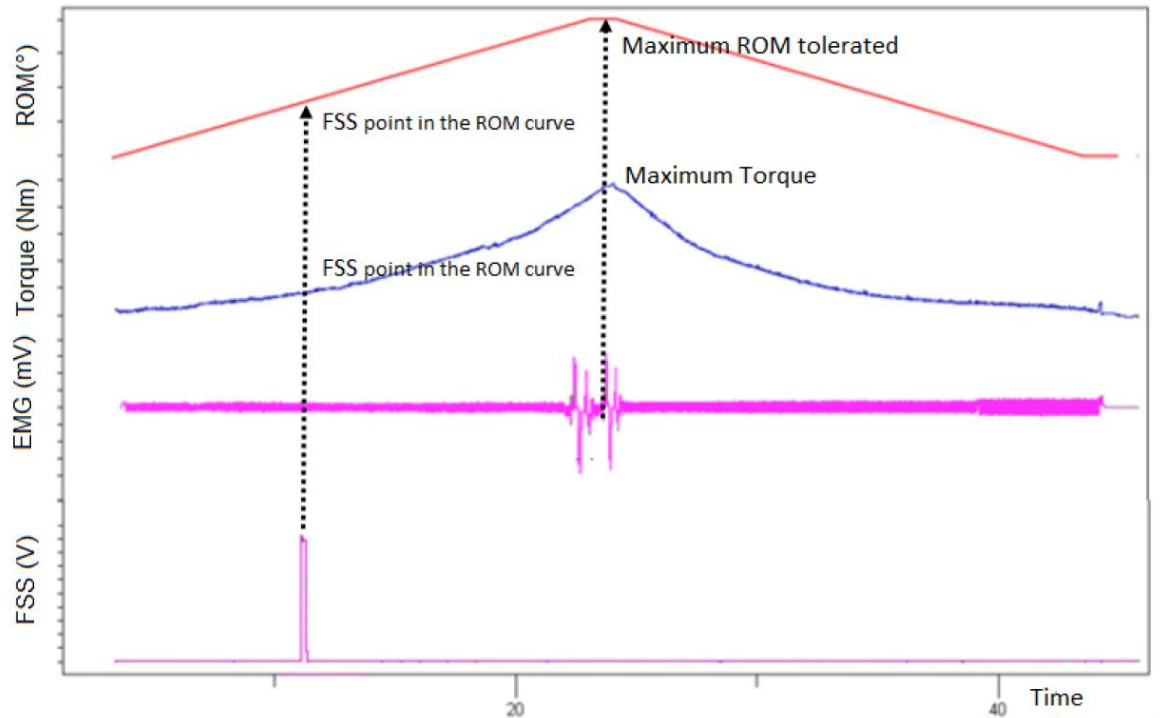

Figure 28: Acquired curves during the tests.

¹⁴ Vide page 39

4.4.1.3 Flexibility Test Equipment - Intervention

The FTE was developed to facilitate the execution of passive stretching (PS), either under a constant angle (CA) or constant torque (CT). The CA is characterized by the maintenance of a pre-determined angle over the time while the CT is the maintenance of a pre-determined torque over time. In both cases, a percentage of the maximal ROM or torque, respectively, is pre-set to standardise the intensity for the stretch training. In each stretching manoeuvre, the same ROM or torque is reached and held for a prescribed duration.

In the CA protocol, the angle is increased until the angle defined by the researcher and held in that position (Figure 29).

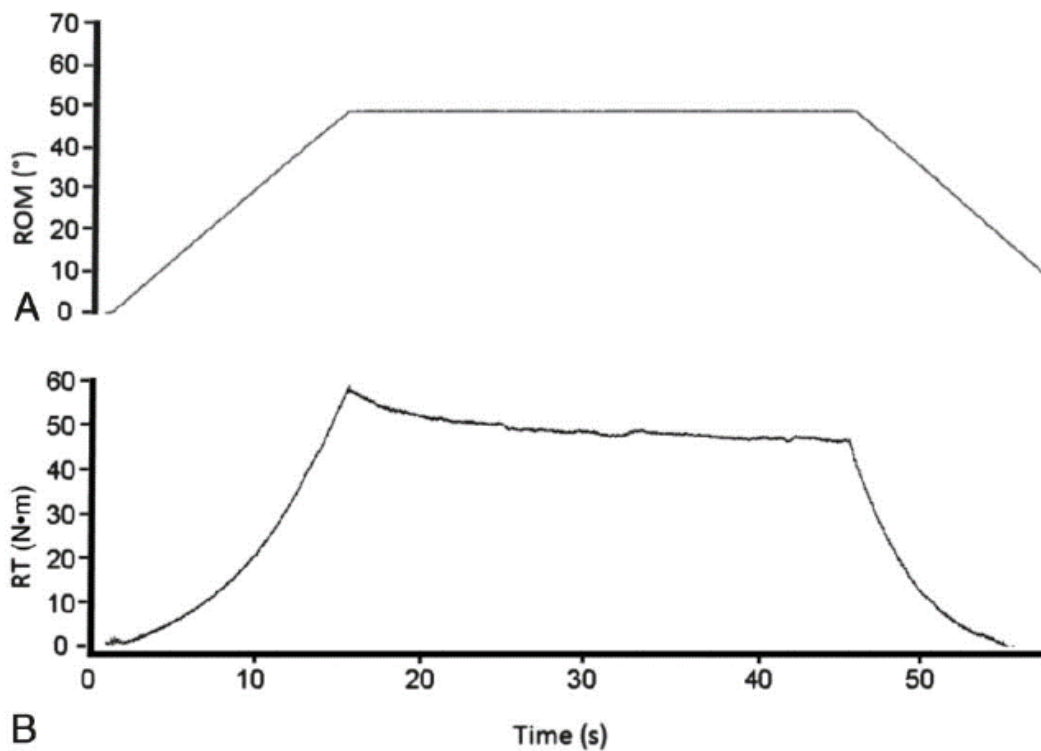

Figure 29: Constant Angle stretching. A) ROM x time curve. B) Torque x time curve. Modified from Cabido et al. (2014).

In the CT protocol, the angle is increased until the torque defined by the researcher, but, due to the tissue accommodation, the ROM needs to be increased whenever the torque decreases to maintain the torque constant (Figure 30).

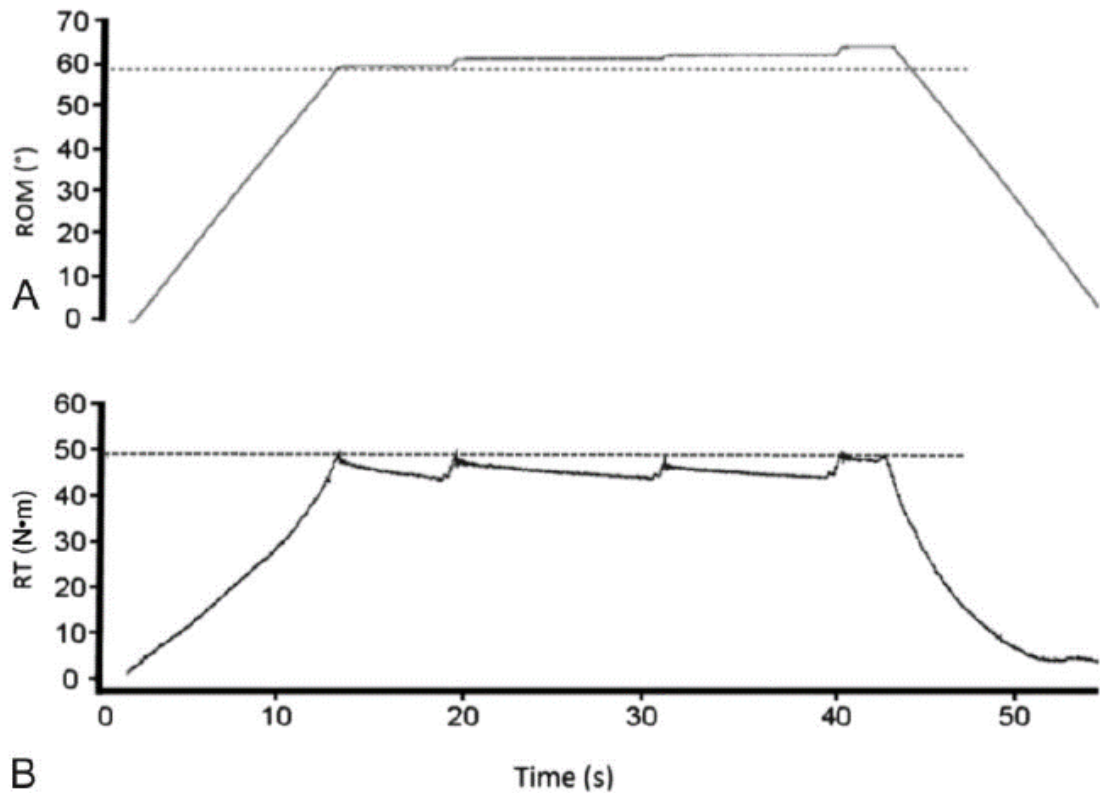

Figure 30: Constant Torque stretching. A) ROM x time curve. B) Torque x time curve. Modified from Cabido et al. (2014).

A screen provided constant visual feedback of ROM and torque vs. time to participants during the familiarisation with the protocol so they would be able to adjust the stretch intensity, if necessary. No visual feedback, however, was provided during Pre- and Post-tests, as this feedback could have influenced the measurements.

4.4.2 Reliability

The number of trials used for analyses, the ICCs, SEMs and percentages of the error for the variables ROM_{Max}, Torque_{Max}, FSS_{ROM} and FSS_{torque} during the Pre-test are shown in Table 10 below.

Table 10: Reliability variables assessed by the Flexibility Test Equipment

Variable	Trial	ICC	SEM	SEM%
ROM _{Max}	6	0.78	14.83 (°)	12
	3 first	0.87	10.87 (°)	9
	3 last	0.69	18.06 (°)	15
Torque _{Max}	6	0.85	16.71 (Nm)	18
	3 first	0.89	12.07 (Nm)	13
	3 last	0.81	20.27 (Nm)	21
FSS _{ROM}	6	0.68	11.69 (°)	13

	3 first	0.89	7.00 (°)	8.4
	3 last	0.44	15.03 (°)	17
FSS _{Torque}	6	0.80	8.96 (Nm)	24
	3 first	0.86	7.52 (Nm)	20
	3 last	0.72	10.20 (Nm)	27

4.5 Discussion

The aim of this study was the further development of a comprehensive ROM assessment apparatus designed to facilitate the assessment of highly flexible populations and the reliability of the measurements taken from it. Different results were found when the ICC was calculated using the average of the first three, last three or average of all the six-trials. ICC values were excellent, 0.75 to 1.0 for ROM_{Max}, torque_{Max}, FSS_{ROM} and FSS_{torque} when the three first trials were used for analyses. Although a little smaller, the analyses of the last three trials were considered good ICC, 0.6 to 0.74 for ROM_{Max}, torque_{Max} and FSS_{torque} with only the FSS_{ROM} being classified as moderate. Therefore, as expected, when all six trials were analysed the ICC ranged from good to excellent for all the variables (>0.67 and <0.85). The SEMs agrees with the ICC; the greater the ICC the smaller the SEMs, but highlights greater variability for the variables related to torque: torque_{Max} and FSS_{torque}, which the isolate ICC would not be able to uncover (Tighe et al., 2010). The greater variability in the SEM is related to a greater standard deviation (Tighe et al., 2010). Given that the FSS_{torque} represents the beginning of the stretch sensation and the torque_{Max} is the maximal torque tolerated during the stretch, both variables provide information about the stretch tolerance and therefore, a more subjective variable, which is predisposed to greater variation.

The reliability obtained by the FTE in comparison with other devices found in the literature is challenging seeing that the devices found neither perform the same movement nor measure the same variables as the FTE. The reliability of a manual manoeuvre was compared to that of a machine for the hamstrings stretching. Both procedures presented $r=0.99$, however, only the ROM was evaluated and the neuromuscular facilitation technique was executed (Burke et al., 2000) while in the current study the stretching technique was the passive stretch with constant torque; different results are expected for different stretch techniques (Fasen et al., 2009, Wyon et al., 2009, Aye et al., 2017). O *Teste de extensão do joelho modificado* (Modified knee extension test) showed an ICC of 0.93 and 0.94 for the submaximal and maximal ROM test respectively (Chagas et al., 2008). Nevertheless, the

device used in this study performed the knee extension maintaining the hip flexed, while the current research performed hip flexion maintaining the knee extended in the FTE. The stretch position should be considered once the effects of hamstring stretching on S_{MTU} vary between passive knee extension and hip flexion stretching manoeuvres (Miyamoto et al., 2017).

The majority of the papers presenting the reliability of the measurements assessed by the equipment used in their studies report results concerning only to the ROM_{Max} . Notwithstanding, (Cabido et al., 2014) presented the ICC and SEM of similar variables as evaluated in the present study; ROM_{Max} : ICC 0.98 - SEM 2.23%, S_{MTU} : ICC 0.83 - SEM 8.86%, FSS_{ROM} : ICC 0.93 - SEM 5.62%. The higher reliability in (Cabido et al., 2014) was probably due to the chosen analysis method, which analysed the average of the two closest values assessed compared to the six trials completed in this study. In addition, the stretch movement was through the knee extension, not hip flexion.

The reliability of the first version of the FTE was also calculated using three trials of Pre- and three trial of Post-tests in addition to the comparison between dancers and non-dancers (Pessali-Marques et al., 2015). The ICC (3,k) for the dancers (D) and for the non-dancers (ND) were respectively $ROM_{Max} = 0.76$ (D) and 0.98 (ND), $Torque_{Max} = 0.99$ (D) and 0.97 (ND), $FSS_{ROM} = 0.97$ (D) and 0.94 (ND) and $FSS_{torque} = 0.94$ (D) and 0.95 (ND), again, the first version performed the knee extension whereas the third version performed the hip flexion.

The FTE showed excellent or good reliability for all the variables analysed with only the FSS_{ROM} , being classified as moderate. Although devices found in the literature seem to present better reliability (ICC ranging from 0.76 to 0.99) when compared to the FTE, it is important to consider some factors that may affect the ICC and make this comparison difficult, such as different stretch techniques, stretch position, and training loads. Distinct stretch techniques may differently affect the biomechanical (Taylor et al., 1990) and neurophysiologic (Moore and Hutton, 1980) properties of the MTU. In addition, the variation in the stretching position (e.g. hip flexion or knee extension) might induce the participation of different structures, such as skin, ligaments, joint capsule, and anterior and posterior surrounding compartment muscles (Riemann et al., 2001), culminating in different tension

applied in the MTU. Different tension during the stretching may bring on compensatory movements (Sullivan et al., 1992) affecting the reliability. Different position for the hamstrings stretching was compared in previous research. Results indicated significant differences between them (Sullivan et al., 1992, Van Dillen et al., 2000, Miyamoto et al., 2017).

Finally, the chosen intensity established aiming to reach ROM_{Max} may also affect the results (Chagas et al., 2008, Freitas et al., 2015). Given that the maximal ROM tolerated is related to pain sensations and even inflammatory process (Apostolopoulos et al., 2015b), procedures where the intensity was lower cause less discomfort and therefore, less compensatory movements, which may increase the reliability. However, this hypothesis needs to be tested.

Additionally, the results obtained comparing the reliability of the first three, last three and six trials of Pre- and Post-test in the present analyses, as showed in Table 1, presented evidence of alteration in the perception of pain during the tests (Jessell and Kjelly, 2003). Further data in this research will provide information about whether this modification in the perception is due to biomechanical or sensory mechanisms.

4.6 Conclusion

The Flexibility Test Equipment is reliable equipment to assess both the biomechanics and sensory properties of the muscle-tendon unit after stretch protocol in populations that require a great range of motion, such as dancers. It may be used for testing and results from later chapters in this thesis will provide information on the reliability of flexibility training using said device.

Chapter 2: Functional and structural characteristics of the MTU and lower limb asymmetries between dancers and non-dancers

Não existe coincidência

There is no coincidence.

5.1 Introduction

The notion that different populations may respond differently to the same stimulus is substantiated by previous research comparing sex (Dedrick et al., 2008, Riemann et al., 2001, Stening et al., 2007), age (Gajdosik et al., 1999) and exercise practiced (Ferry et al., 2011). Recently, distinct responses found between dancers and non-dancers has been attracting attention (Nielsen et al., 1993, Koceja et al., 1991), with dancers presenting differences not only in terms of physical characteristics (Amaral et al., 2008) but also in terms of pain sensation and reporting (Anderson and Hanrahan, 2008, Claus and MacDonald, 2017, Silva and Enumo, 2016, Tajet-Foxell and Rose, 1995, Thomas and Tarr, 2009), reflex results (Nielsen et al., 1993, Nigmatullina et al., 2013), training results (Mcconneell and Oceanside, 2013, Pessali-Marques, 2015), eating disorders, personality (Bakker, 1988), body image (Radell et al., 1993, Adame et al., 1991, Santiago and Santos, 2013, Nerini, 2015), muscle strength (Bennell et al., 1999, Rowley et al., 2015) and body composition (Ferry et al., 2011, Kadel et al., 2005, Frasson et al., 2009)¹⁵, just a few, however, were performed comparing flexibility and jump capabilities, which are requirements for dancers to reach professional standards.

A study comparing the H-reflex response between dancers, trained populations from different sports including and sedentary individuals found a smaller reflex in the dancers' group (Nielsen et al., 1993). Furthermore, isometric strength of the *triceps surae* muscle was smaller and the half-relaxation time was longer in dancers compared to a non-trained group, following a mechanical stimulus applied to the Achilles tendon. The authors suggested that these results may be due to a smaller S_{MTU} in dancers, assuming that dancers exhibit a smaller transmission of a mechanical load than control individuals (Koceja et al., 1991). Pessali-Marques (2015) analysed the biomechanical and sensory response of the MTU to a stretching session comparing professional dancers to non-dancers and found a distinct response to the same protocol. Dancers presented a greater increase in the maximal ROM compared to non-dancers, but no differences in the biomechanical properties of the muscle were found between the groups. The higher ROM in dancers was suggested to occur due to a greater stretch tolerance. Although dancers tolerated a greater ROM_{Max} , it is

¹⁵ Vide complete table of papers comparing dancers vs non-dancers on Appendix E pages 275. The literature search was conducted over a period from 1994 to October 2018 using the PubMed database and the following keywords: dancers, non-dancers, sedentary.

counterintuitive that in fact, they perceived pain in early stretch stages more so than the non-dancers. This observation was true for both, after the stretching and when comparing post- to pre-test. This author was not able to propose a physiological or biomechanical rationale for the contradiction in the pain tolerance data but highlights the importance of understanding pain coping strategies differences between dancers and non-dancers. (Tajet-Foxell and Rose, 1995), compared pain tolerance in dancers and non-dancers and found greater tolerance in the first group. The authors, however, did not explain the mechanisms related to these differences. Thus, questions about general pain and pain coping strategies would provide important information to understand stretch pain.

Regarding jumping, (Volkerding and Ketcham, 2013) compared the kinematics and kinetics characteristics when landing from different heights and found that dancers utilize proprioceptive input more effectively, however, drop jump is not a common movement in dance routines, being the vertical jumps more specific. No other studies, in the best of the author's knowledge, were found assessing flexibility nor vertical jumps and the possible factors that may affect both capabilities.

To summarise, muscle cross-sectional area (Weppeler and Magnusson, 2010), muscle thickness, S_{MTU} (Morse et al., 2008) and the concentration of female hormones, are some of the factors that may play a role in the modulation of flexibility (Magnusson, 1998) and jump. In addition, the excitability of proprioceptors, responsible for the pain and tension perception, may also influence the functional response of the MTU to the stress caused by (Mense, 2010). In view of these observations, it would follow that differences in the muscle structure, function (in this case flexibility and jump), pain tolerance and coping strategies, and hormonal concentration between young female non-dancers and dancers would provide insights into the factors that might explain disparities between these populations. The aim of this chapter was, therefore, to compare the functional and structural characteristics of the MTU between dancers and non-dancers. Anthropometry, body composition, muscle structure, flexibility, vertical jump, pain tolerance, pain coping strategies and hormonal status were assessed for group and lower limb comparison. The study was pertinent given the importance of flexibility and jump movements for dancer performance. The structural modifications of the MTU, as would be expected to occur

following chronic practice of movements requiring these capabilities, also accounting for the Structure-function relationship, it was hypothesised that dancers would present differences in functional, and consequently, structural characteristics when compared to non-dancers. Specifically, dancers would have greater performance in flexibility and jump, greater pain tolerance, CSA, lean and ST thickness, but smaller fat thickness and S_{MTU} when compared to non-dancers. It was also hypothesised that were endocrine factors modulate these MTU characteristics, the group differences would still exist after correction for hormone covariates.

5.2 Methods

5.2.1 Participants

Thirty-one participants comprised the study; 20 non-dancers (Mean [SD]: age 22.4 [1.77] years, body mass 65.06 [15.59] kg, height 1.64 [0.05] m) and 11 dance students (Mean [SD]: age 23.5 [2.94] years, body mass 67.65 [15.62] kg, height 1.63 [0.05] m). Ethics, inclusion and exclusion criteria are described in the Overall Methods¹⁶. Participants filled a questionnaire informing the average time dancing and practising other physical activities per week (Tables 11 and 12) and any injury incurred (Table 13).

Table 11: Weekly structured physical activity (average \pm standard deviation - hours)

	Dancers	Non-dancers
Dance	10.50 \pm 1.73	4.00 \pm 0.00
Other physical activities	6.12 \pm 2.36	6.70 \pm 5.49

Table 12: Other physical activities practised (absolute [N] and percentage [%])

	Dancers		Non-dancers	
	N (11)	%	N (20)	%
Weightlifting	9	82	11	55
Aerobic	5	45	13	65
Gymnastics or Martial Arts	4	36	3	15
Yoga Pilates	4	36	3	15
Team sports	3	27	8	40
Other activities	3	27	6	30
Other activities practised	Cheerleading, Netball, Pole Dance		Tennis, Basketball, Swimming, Horse Riding, Adventurous Activities	

¹⁶ Vide Overall Methods section 3.1 and 3.2 pages 53

Table 13: Reported injuries

	Dancers		Non-dancers	
	N (11)	%	N (20)	%
Last 12 months	4	36	4	20
Before last 12 months	2	18	5	25

5.2.2 Procedures

A menstrual cycle calendar¹⁷ and a digital basal thermometer (Geratherm, Geratherm Medical, Geschwenda, Germany) were given to participants on average two to three months before the laboratory-based tests. The basal temperature was measured every day just after waking up and written down in °C within two decimal places, specifying sampling time. The dates of the menstruation phase, from the first to the last day, were circled or highlighted in the calendar. In addition, at least one ovulation was verified using an ovulation kit¹⁸ given to participants five days before the predicted ovulation. Thus, the individual's menstrual cycle length could be calculated to increase the chances to collect the samples in the hormonal peak as intended.

Participants were tested on two separate days with a 24 to 48-hour interval (Figure 31). Familiarization¹⁹ for the flexibility and jump tests was performed in the first session and the tests were performed on the second session. strategically booked two days before the predicted ovulation (oestrogen peak). On the second session, participants attended the Phlebotomy Laboratory at Manchester Metropolitan University in the morning after an overnight fast of 12 hours. They were asked to drink 500 ml of water just after waking up (approximately two hours before data collection) to guarantee the hydration level (according to the ACSM recommendations) for the phlebotomy²⁰. Following the phlebotomy procedures, participants had breakfast consisting of fruit tea, water, two slices of wholegrain bread with butter or jam, yoghurt and fruit (approximately 250 kcal). Anthropometry²¹ measurements were performed, then, participants laid supine on a physiotherapy bed for

¹⁷ Vide Overall Methods section 3.3.1 page 58. Example of a filled calendar Appendix R page 332

¹⁸ Vide Overall Methods section 3.3.1 page 59

¹⁹ Vide Overall Methods section 3.3.13 pages 78

²⁰ Vide Overall Methods section 3.3.2 pages 59

²¹ Vide Overall Methods section 3.3.12 page 78

the ultrasound²² recordings of the semitendinosus (ST), followed by the positioning of the electromyography electrodes²³.

Participants stood on the force platforms, one foot on each plate, to perform the jump Pre-test²⁴ consisting of three maximal CMJ followed by three maximal SJ. No warm-up before the jumps was performed. Then, participants were positioned on the Flexibility Test Equipment (FTE) and performed the first flexibility assessment or Pre-test flexibility²⁵, which consisted of repeat six trials aiming to reach the maximum ROM tolerated (ROM_{Max}).

Finally, participants undertook the pain mixed-method assessment. They were randomly assigned to perform the IWT²⁶ followed by the Questionnaires²⁷, or the Questionnaires followed by the IWT to avoid any order effect (Figure 32).

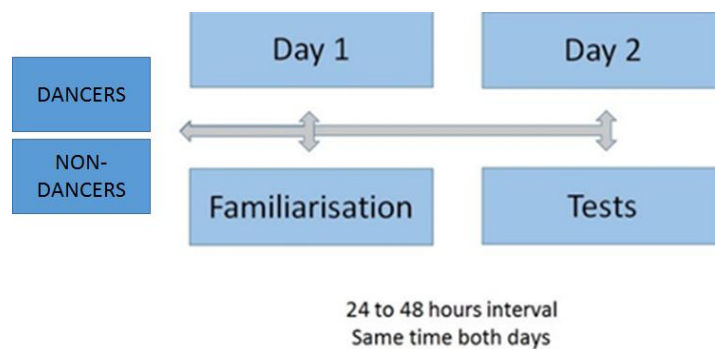

Figure 31: Illustration of the experimental procedures

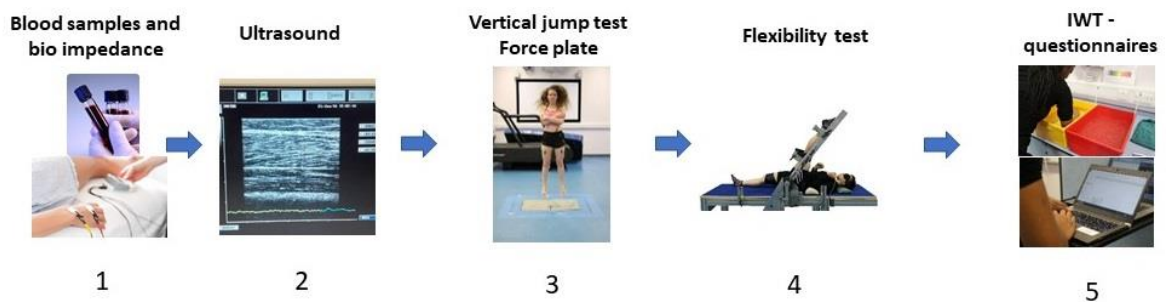

Figure 32: Illustration of the tests' order

²² Vide Overall Methods section 3.3.4 page 63

²³ Vide Overall Methods section 3.3.8 page 73

²⁴ Vide Overall Methods section 3.3.7 page 72

²⁵ Vide Overall Methods section 3.3.5 page 66

²⁶ Vide Overall Methods section 3.3.9 page 76

²⁷ Vide Overall Methods section 3.3.11 pages 77-78

5.2.3 Outcome variables

Table 14 summarises the assessed variables in the current chapter²⁸.

Table 14: Outcome variables Chapter 2

Flexibility	Vertical jump	Pain mix method	EMG	Ultrasound	Hormone
ROM _{Max} Torque _{Max} FSS _{ROM} FSS _{torque} S _{MTU} Energy	Jump height Impulse Force _{peak} V _{Take-off}	SEFIP PASS VAS Ice Water Test	EMG _{RF} EMG _{ST} during CMJ and SJ	Semitendinosus, Fat and Lean thickness, CSA, Muscle length, Muscle width.	Oestrogen, Progesterone and Relaxin (serum) Cholesterol, Lactate, Glucose and Triglycerides (whole blood)

ROM: Range of motion, Max: Maximal, FSS: first sensation of stretch, S: stiffness, MTU: muscle-tendon unit, V: velocity, SEFIP: Self-Estimated Functional Inability because of Pain, PASS: Pain Anxiety Symptom Scale, VAS: visual analogue scale, EMG: electromyography, RF: rectus femoris, ST: semitendinosus, CMJ: countermovement jump, SJ: squat jump, CSA: cross-sectional area.

5.3 Statistical analyses

SPSS Statistics (v24 International Business Machines Corporation, New York, USA) was used for statistical analyses. Levene and Shapiro-Wilk statistic tests were performed to test the homogeneity of variance and the normality of the data, respectively. The comparison between dancers and non-dancers, and flexible (dominant limb – D) vs. least flexible (non-dominant limb - nD) lower limb (hereafter referred to leg dominance) for all the dependent variables was performed using the ANOVA repeated measures (when parametric) and the Kruskal-Wallis test (when non-parametric). Post hoc pairwise comparisons were performed, when necessary, to highlight any interaction. Unpaired t-tests were performed to compare groups (when parametric) and Mann-Whitney (when non-parametric). Finally, Unpaired t-tests were performed to compare the hormonal concentration between the groups and bivariate correlation were performed to identify any association between the hormonal concentrations and outcome measures, in order to determine the influence of any covariance. Thus, covariance analyses (ANCOVA) were performed to factor out any uncovered hormonal influence on the dependent variables. The statistical significance adopted was $\alpha \leq 0.05$, study power at $\beta \geq 0.8$ (and effect size $p\epsilon^2 \geq 0.2$ where study power was adequate).

²⁸ For complete description of variables vide Table 8 pages 56-58

5.4 Results

5.4.1 Parametricity checks

All variables but FSS_{torque} ($P=0.037$) and peak force ($P=0.018$) for the CMJ in the non-dominant limb, total force_{peak} ($P=0.005$) for the SJ, upper back ($P=0.015$), back thighs ($P=0.036$), shoulders ($P=0.001$) and ankles/feet ($P=0.004$) from the SEFIP questionnaire presented significance level > 0.05 for the homogeneity test. Table 15 shows the non-parametric data²⁹. The characterisation of the NN and DCN groups is shown in Table 16.

Table 15: Non-parametric data – Shapiro Wilk.

Lower limb	Variable	Group	<i>P</i>
Dominant limb	Length	Dancers	0.049
	Width	Non-dancers	0.019
Non-dominant limb	ST thickness	Dancers	0.007
	CMJ Impulse	Non-dancers	0.006
Dominant limb	CMJ Force _{peak}	Non-dancers	0.001
	CMJ Impulse	Dancers	0.001
Non-dominant limb	CMJ Force _{peak}	Non-dancers	0.001
	CMJ total force _{peak}	Non-dancers	0.002
		Dancers	0.042
Dominant limb	SJ Impulse	Non-dancers	0.001
Non-dominant limb	SJ Impulse	Non-dancers	0.001
	SJ Force _{peak}	Non-dancers	0.013
Combined limbs	Oestrogen	Non-dancers	0.001
		Dancers	0.001
	Relaxin	Non-dancers	0.001
Combined limbs	Oestrogen	Both groups	0.001
	Progesterone	Both groups	0.001
	Relaxin	Both groups	0.001
Dominant limb	EMG _{RF} CMJ	Non-dancers	0.003
Non-dominant limb	EMG _{RF} CMJ	Non-dancers	0.005
	EMG _{ST} CMJ	Non-dancers	0.006
Dominant limb		EMG _{ST} CMJ	Dancers
Non-dominant limb	EMG _{ST} CMJ	Non-dancers	0.020
Dominant limb	EMG _{RF} SJ	Non-dancers	0.014
Dominant limb	EMG _{ST} SJ	Dancers	0.021
Non-dominant limb	EMG _{ST} SJ	Non-dancers	0.015

P: statistical significance, ST: Semitendinosus, CMJ: Countermovement jump, SJ: Squat jump, EMG: Electromyographic activity, RF: Rectus femoris.

Table 16: Characterisation of the participants (average \pm standard deviation)

	Non-dancers - NN	Dancers - DCN
Age (years)	22.4 \pm 1.77	23.5 \pm 2.94
Height (m)	1.64 \pm 0.05	1.63 \pm 0.05
Body mass (kg)	65.1 \pm 15.6	67.6 \pm 15.6
Fat %	28.6 \pm 9.1	30.3 \pm 6.8
Fat (kg)	19.8 \pm 11.1	21.3 \pm 10.6
Lean %	71.4 \pm 9.1	69.7 \pm 6.8
Lean (kg)	45.2 \pm 5.9	46.4 \pm 5.8

²⁹ See complete table in the Appendix F, page 281.

Water %	49.7 ± 7.3	48.2 ± 5.7
Water (L)	31.3 ± 3.5	32.2 ± 4.2
Basal metabolism (j)	6323.2 ± 603.4	6460.7 ± 588.1
Body mass index	24.0 ± 5.7	25.4 ± 4.5
Cholesterol (mmol/L)	5.1 ± 0.6	4.7 ± 0.3
Triglycerides (mmol/L)	1.3 ± 0.3	1.9 ± 1.2
Glucose (mmol/L)	4.9 ± 3.0	5.9 ± 3.2
Lactate (mmol/L)	1.7 ± 0.8	1.7 ± 0.7

5.4.2 MTU functional characteristics and flexibility performance: lower limb dominance and group comparisons

A main effect of group ($F_{23,87} P<0.01$; $\eta^2_p=0.46$; $\beta=0.99$) and lower limb (LL) dominance ($F_{18,37} P<0.01$; $\eta^2_p=0.396$; $\beta=0.985$) was found for the ROM_{Max}. ROM_{Max} was greater in the DCN compared to the NN group (collapsed means across conditions; $133.21^\circ \pm 5.23$ and $101.86^\circ \pm 3.7$ respectively, $P<0.01$) and in the D compared to the nD leg (collapsed means across groups; $119.90^\circ \pm 3.26$ and $115.17^\circ \pm 3.24$ respectively, $P<0.01$). However, no interaction (group [DCN and NN] x LL dominance [D and nD]) was observed ($F_{0,001} P=0.97$; $\eta^2_p=0.01$; $\beta=0.05$) for ROM_{Max} (Figure 33).

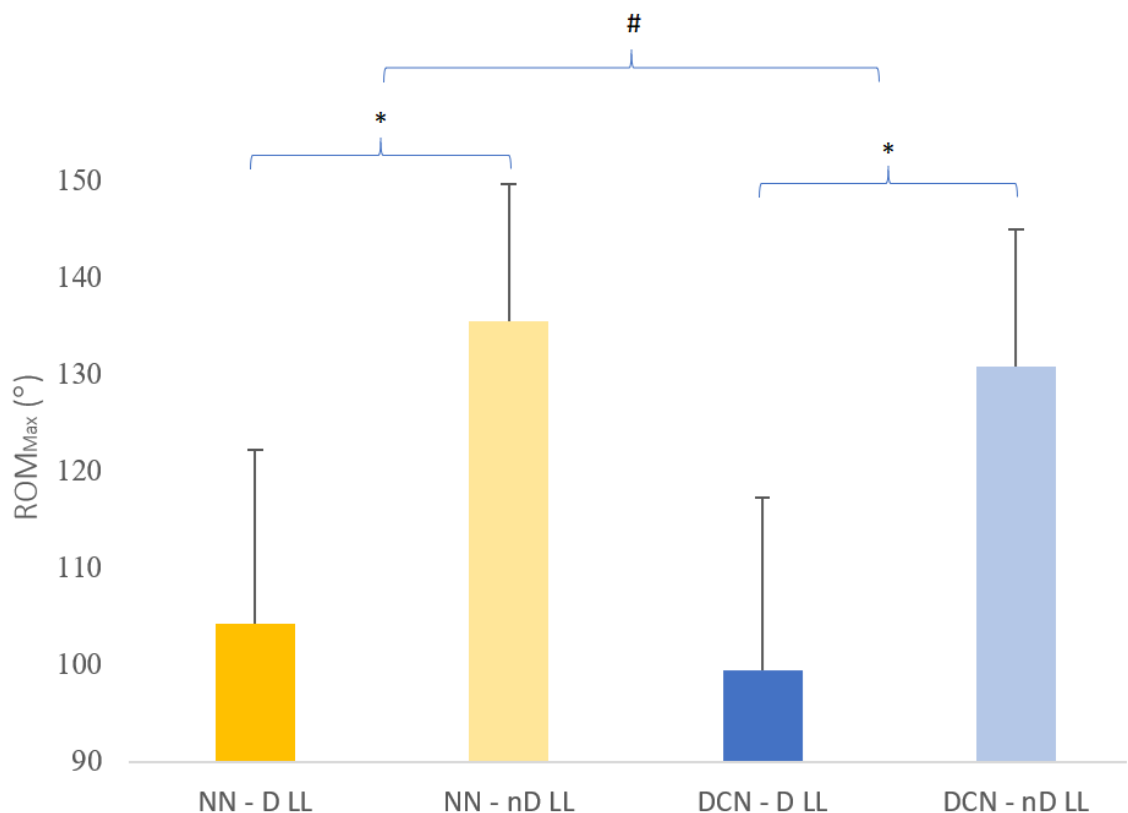

Figure 33: ROM_{Max} average and standard deviation for the comparisons between group: non-dancers (NN) x dancers (DCN); and, lower limb dominance: dominant lower limb (D LL) x non-dominant lower limb (nD LL). *statistical significance difference between the limbs. #statistical significance difference between the groups.

There was no main effect of LL dominance ($F_{0.21} P=0.651$; $\eta^2_p=0.007$; $\beta=0.073$), but a main effect of group ($F_{15.96} P<0.01$; $\eta^2_p=0.36$; $\beta=0.97$) for $\text{torque}_{\text{Max}}$, which was greater in the DCN compared to the NN group (collapsed means across conditions; $143.25 \text{ N} \pm 10.01$ and $94.22 \text{ N} \pm 7.08$ respectively, $P<0.01$). In consequence, no interaction for (group [DCN and NN] x LL dominance [D and nD]) was observed ($F_{0.816} P=0.374$; $\eta^2_p=0.02$; $\beta=0.14$) for $\text{torque}_{\text{Max}}$ (Figure 34).

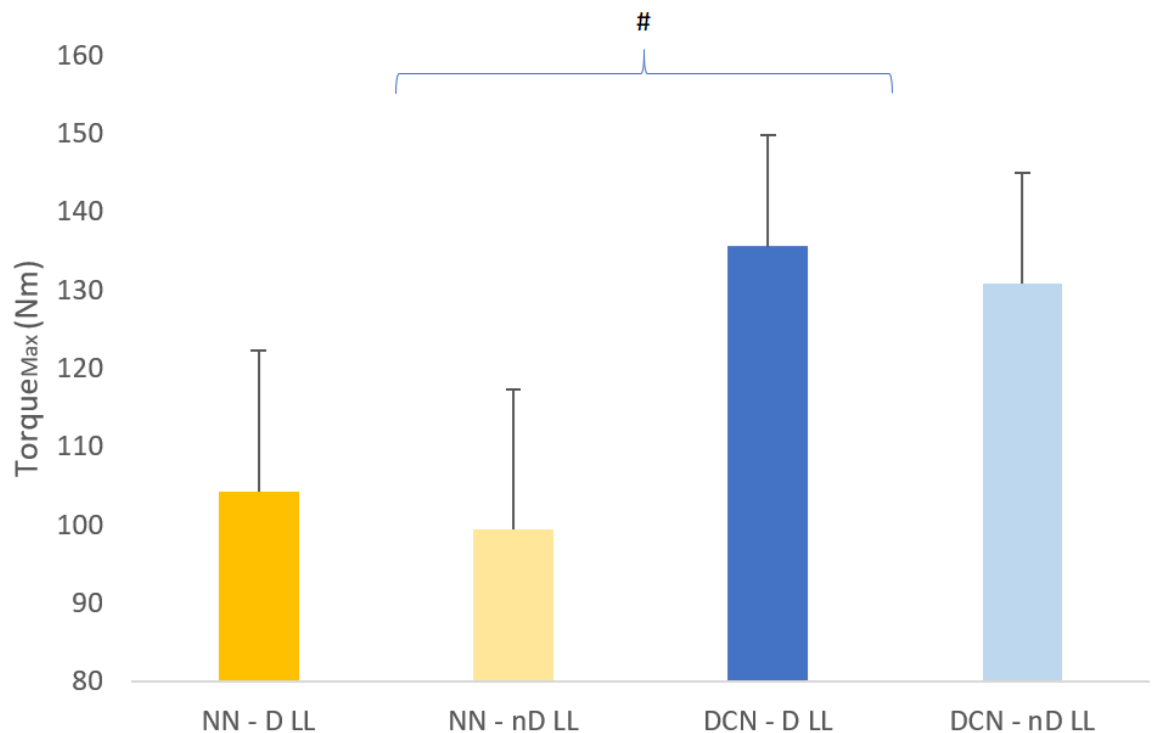

Figure 34: Torque_{Max} average and standard deviation for the comparisons between group: non-dancers (NN) x dancers (DCN); and, lower limb dominance: dominant lower limb (D LL) x non-dominant lower limb (nD LL). #statistical significance between the groups.

No main effect of LL dominance ($F_{0.008} P=0.931$; $\eta^2_p=0.001$; $\beta=0.051$) was found, but a main effect of group ($F_{23.57} P<0.01$; $\eta^2_p=0.457$; $\beta=0.99$) was observed for FSS_{ROM} , whereby this parameter was greater in the DCN compared to the NN group (collapsed means across conditions; $98.36^\circ \pm 4.17$ and $73.56^\circ \pm 2.94$ respectively, $P<0.01$). No interaction (group [DCN and NN] x LL dominance [D and nD]) was observed ($F_{1.881} P=0.181$; $\eta^2_p=0.06$; $\beta=0.26$) for FSS_{ROM} (Figure 35).

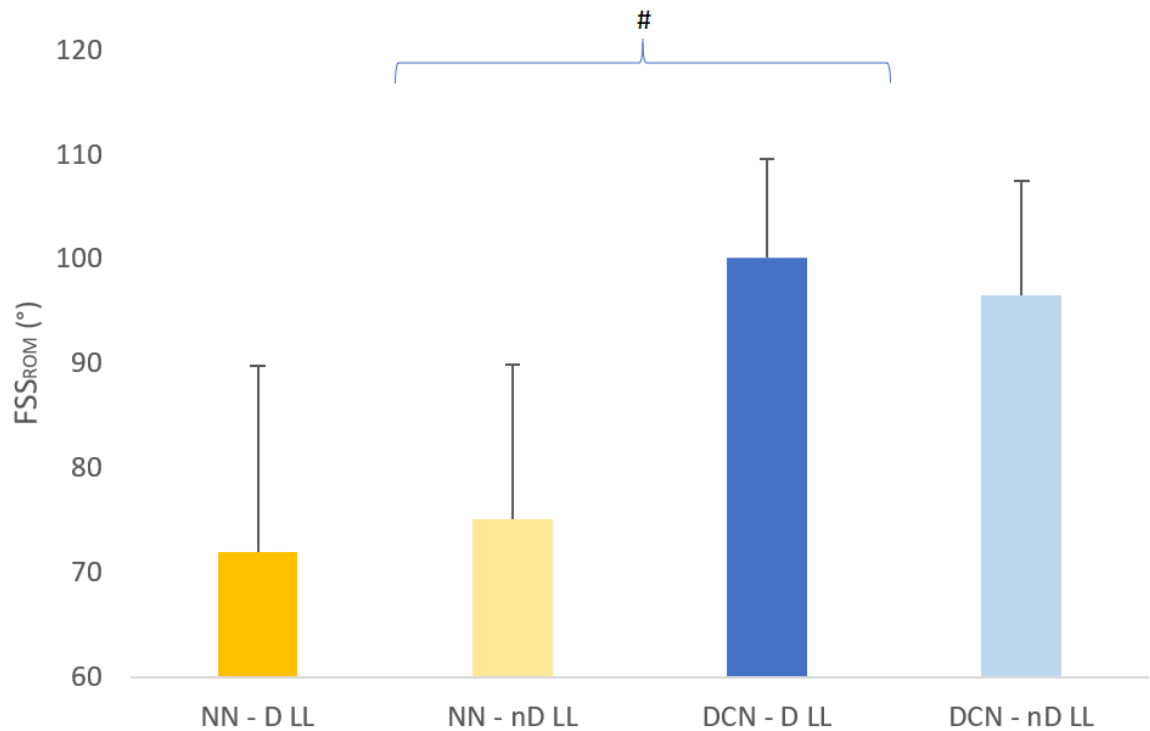

Figure 35: FSS_{ROM} average and standard deviation for the comparisons between group: non-dancers (NN) x dancers (DCN); and, lower limb dominance: dominant lower limb (D LL) x non-dominant lower limb (nD LL). #statistical significance between the groups.

Neither a main effect of LL dominance ($F_{1.332} P=0.258$; $\eta^2_p=0.045$; $\beta=0.20$) nor main effect of group ($F_{2.011} P=0.167$; $\eta^2_p=0.067$; $\beta=0.28$) was found for FSS_{torque}. In addition, no interaction (group [DCN and NN] x LL dominance [D and nD]) was observed ($F_{0.106} P=0.747$; $\eta^2_p=0.04$; $\beta=0.061$) for FSS_{torque}.

Neither a main effect of LL dominance ($F_{2.237} P=0.146$; $\eta^2_p=0.074$; $\beta=0.303$) nor main effect of group ($F_{3.561} P=0.070$; $\eta^2_p=0.113$; $\beta=0.445$) was found for S_{MTU}. Thus, no interaction (group [DCN and NN] x LL dominance [D and nD]) was observed ($F_{1.351} P=0.255$; $\eta^2_p=0.046$; $\beta=0.202$).

No main effect of LL dominance ($F_{0.325} P=0.325$; $\eta^2_p=0.035$; $\beta=0.162$), but a main effect of group ($F_{11.900} P=0.002$; $\eta^2_p=0.298$; $\beta=0.915$) was found for Energy, which was greater in the DCN compared to the NN group (collapsed means across conditions; $283.00 \text{ Nm}^\circ \pm 22.44$ and $188.16 \text{ Nm}^\circ \pm 15.88$ respectively, $P<0.01$). In consequence, no interaction (group [DCN and NN] x LL dominance [D and nD]) was found ($F_{0.227} P=0.638$; $\eta^2_p=0.008$; $\beta=0.075$) (Figure 36).

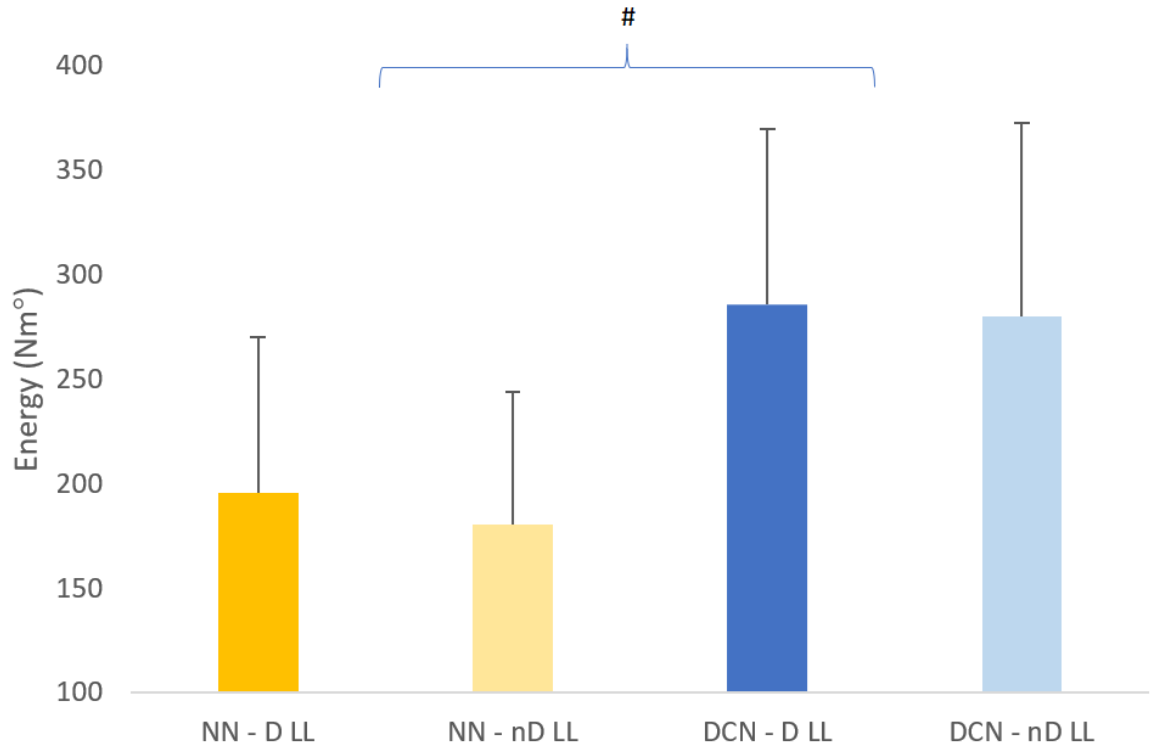

Figure 36: Energy average and standard deviation for the comparisons between group: non-dancers (NN) x dancers (DCN); and, lower limb dominance: dominant lower limb (D LL) x non-dominant lower limb (nD LL). #statistical significance between the groups.

5.4.3 MTU functional characteristics and jump performance: group comparisons

Unpaired t-tests (when parametric) and Mann-Whitney (when non-parametric) were performed for the group (DCN x NN) comparison. Results are shown in the table below (Table 17).

Table 17: Group comparison for the vertical jump performance.

Variables	CMJ		SJ	
	Average ± sd	P	Average ± sd	P
V _{take-off}	DCN 5.34 ± 0.40	0.899	DCN 2.00 ± 0.28	0.798
	NN 5.31 ± 0.64		NN 1.97 ± 0.29	
Jump height	DCN 0.22 ± 0.05	0.961	DCN 0.20 ± 0.05	0.894
	NN 0.20 ± 0.05		NN 0.20 ± 0.05	
Total impulse	DCN 147.90 ± 29.47	0.709	DCN 143.55 ± 27.43	0.379
	NN 139.67 ± 32.55		NN 138.20 ± 32.30	
Total force _{peak}	DCN 824.25 ± 370.91	0.294	DCN 768.06 ± 59.41	0.005
	NN 819.84 ± 235.01		NN 715.89 ± 222.67	

P: significance level. Sd: standard deviation. V: velocity. CMJ: countermovement jump. SJ: squat jump. Grey cells: non-parametric analyses. White cells: parametric analyses. Variables in light: not statistically significantly different. Variables in bold: statistically significantly different.

5.4.4 MTU functional characteristics and jump performance: Lower limb dominance and group comparisons

Wilcoxon showed non-statistically significant difference for the CMJ force_{peak} in the LL dominance comparison for the DCN ($Z_{-0.357}$, $P=0.385$) (average \pm sd: D 407.89 ± 80.20 and nD 396.20 ± 71.89). Similar results were found for the NN ($Z_{-0.448}$, $P=0.337$) (average \pm sd: D 403.40 ± 155.09 and nD 430.33 ± 219.77). Mann-Whitney U tests showed no statistically significant difference for CMJ force_{peak} between the groups neither for the D LL ($Z_{-1.276}$, $P=0.214$) with a mean rank score of 18.40 for DCN and 14.05 for NN, nor for the nD LL ($Z_{-0.001}$, $P=0.509$) with a mean rank score of 15.50 for DCN and 15.50 for NN.

Wilcoxon showed a non-statistically significant difference for the CMJ impulse in the LL dominance comparison for the DCN ($Z_{-0.764}$, $P=0.246$) (average \pm sd: D 69.86 ± 26.10 and nD 78.90 ± 15.64). Also, no significant difference was found for the NN ($Z_{-0.112}$, $P=0.464$) (average \pm sd: D 67.30 ± 42.14 and nD 72.36 ± 36.13). Mann-Whitney U tests showed no statistically significant difference for CMJ impulse between the groups neither for the D LL ($Z_{-0.088}$, $P=0.474$) with a mean rank score of 15.30 for DCN and 15.60 for NN nor for the nD LL ($Z_{-1.628}$, $P=0.055$) with a mean rank score of 19.20 for DCN and 13.65 for NN.

Wilcoxon showed non-statistically significant difference for the SJ force_{peak} in the LL dominance comparison for the DCN ($Z_{-1.172}$, $P=0.138$) (average \pm sd: D 434.04 ± 140.20 and nD 409.01 ± 104.71). Results were also not statistically significantly different for the NN ($Z_{-0.161}$, $P=0.445$) (average \pm sd: D 380.64 ± 133.89 and nD 362.82 ± 113.98). Mann-Whitney U tests showed no statistically significant difference for SJ force_{peak} between the groups neither for the D LL ($Z_{-1.147}$, $P=0.133$) with a mean rank score of 17.50 for DCN and 13.68 for NN nor for the nD LL ($Z_{-1.285}$, $P=0.106$) with a mean rank score of 17.80 for DCN and 13.53 for NN.

Wilcoxon showed non-statistical significance difference for the SJ impulse in the LL dominance comparison for the DCN ($Z_{-0.153}$, $P=0.461$) (average \pm sd: D 69.30 ± 71.18 and nD 74.82 ± 73.62). Similarly, results were not statistically significant for the NN ($Z_{-1.328}$, $P=0.098$) (average \pm sd: D 106.94 ± 232.97 and nD 31.26 ± 224.24). Mann-Whitney U tests showed no statistically significant difference for SJ impulse between the groups neither for the nD LL ($Z_{-0.001}$, $P=0.509$) with a mean rank score of 15.50 for DCN and 15.50 for NN.

-0.642, $P=0.271$) with a mean rank score of 16.40 for DCN and 14.26 for NN nor for the D LL ($Z_{-0.275}$, $P=0.402$) with a mean rank score of 15.60 for DCN and 14.68 for NN.

Wilcoxon showed non-statistical significance difference for the CMJ EMG_{RF} in the LL dominance comparison for the DCN ($Z_{-1.572}$, $P=0.078$) (average \pm sd: D 7.12 ± 3.86 and nD 8.19 ± 3.55). Inversely, results were statistically significant for the NN ($Z_{-0.052}$, $P=0.049$), with the D LL being smaller than the nD LL (average \pm sd: D 7.71 ± 4.66 and nD 9.51 ± 7.11). Mann-Whitney U tests showed no statistically significant difference for CMJ EMG_{RF} between the groups neither for the nD LL ($Z_{-0.159}$, $P=0.451$) with a mean rank score of 12.86 for DCN and 12.35 for NN nor for the D LL ($Z_{-0.413}$, $P=0.355$) with a mean rank score of 11.57 for DCN and 12.88 for NN (Figure 37). CMJ EMG_{RF} values at the peak, rest and ratio are presented in Table 18.

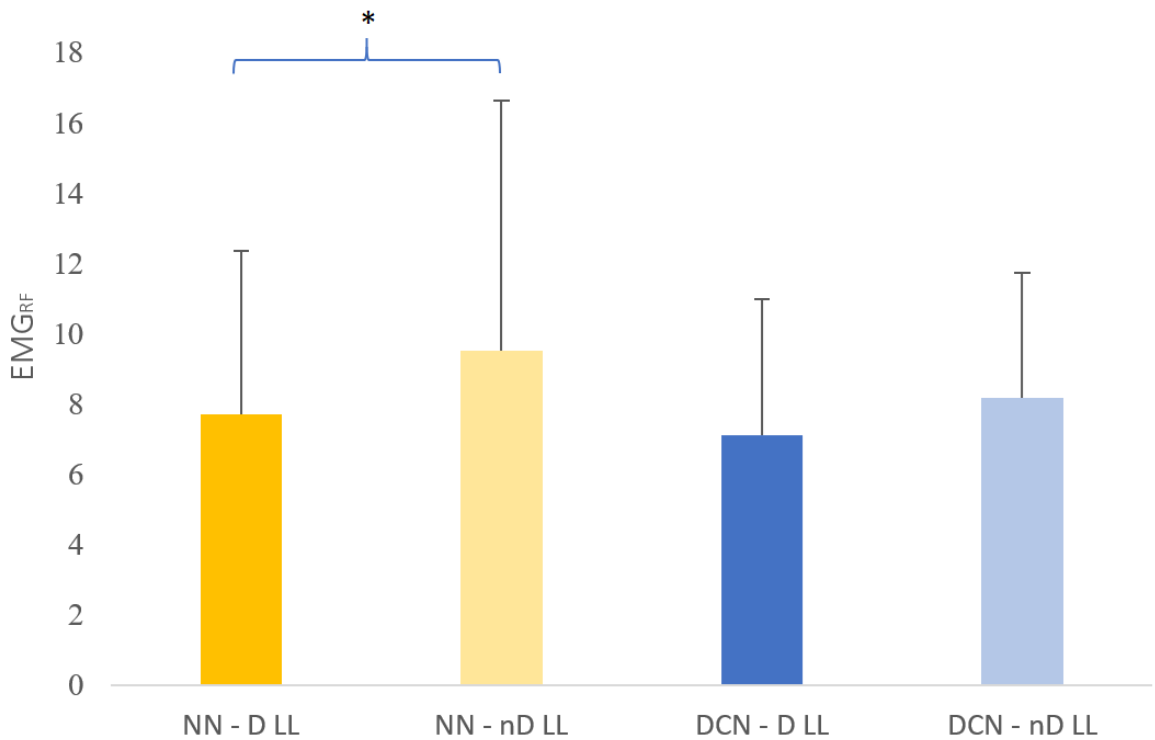

Figure 37: EMG_{RF} average and standard deviation for the comparisons between group: non-dancers (NN) x dancers (DCN); and, lower limb dominance: dominant lower limb (D LL) x non-dominant lower limb (nD LL). * statistical significance between the limbs. #statistical significance between the groups.

Table 18: CMJ EMG_{RF} Peak, Rest and Ratio (average \pm standard deviation)

		Dancers		Non-dancers	
CMJ	Dominant	EMG_{RF} Peak	$1.85E-04 \pm 7.47E-05$ V	$3.89E-04 \pm 8.71E-04$ V	
		EMG_{RF} Rest	$2.59E-06 \pm 4.06E-07$ V	$3.90E-06 \pm 3.79E-06$ V	
		EMG_{RF} Ratio	$7.49E+07 \pm 3.74E+07$	$7.24E+07 \pm 4.21E+07$	
	Non-dominant	EMG_{RF} Peak	$2.67E-04 \pm 1.91E-04$ V	$2.90E-04 \pm 4.55E-04$ V	
		EMG_{RF} Rest	$3.09E-06 \pm 1.05E-06$ V	$2.84E-06 \pm 1.50E-06$ V	

		EMG_{RF} Ratio	9.46E+07 ± 5.82E+07	9.33E+07 ± 6.27E+07
--	--	-------------------------------	---------------------	---------------------

CMJ: Countermovement jump. EMG: Electromyography. RF: Rectus femoris. Ratio: peak/rest.

Wilcoxon showed non-statistical significance difference for the CMJ EMG_{ST} in the LL dominance comparison for the DCN ($Z_{-1.153}$, $P=0.156$) (average ± sd: D 2.15 ± 1.17 and nD 3.78 ± 3.18). Similarly, results were not statistically significant for the NN ($Z_{-0.103}$, $P=0.470$) (average ± sd: D 3.12 ± 2.22 and nD 2.78 ± 1.87). Mann-Whitney U tests showed no statistically significant difference for CMJ EMG_{ST} between the groups neither for the nD LL ($Z_{-0.794}$, $P=0.228$) with a mean rank score of 14.29 for DCN and 11.76 for NN nor for the D LL ($Z_{-0.540}$, $P=0.310$) with a mean rank score of 11.29 for DCN and 13.00 for NN. CMJ EMG_{ST} values at the peak, rest and ratio are presented in Table 19.

Table 19: CMJ EMG_{ST} Peak, Rest and Ratio (average ± standard deviation)

			Dancers	Non-dancers
CMJ	Dominant	EMG_{ST} Peak	1.08E-04 ± 1.11E-04 V	9.59E-05 ± 5.93E-05 V
		EMG_{ST} Rest	5.18E-06 ± 3.06E-06 V	3.70E-06 ± 1.95E-06 V
		EMG_{ST} Ratio	1.95E+07 ± 1.03E+07	3.07E+07 ± 2.11E+07
	Non-dominant	EMG_{ST} Peak	1.27E-04 ± 7.08E-05 V	9.37E-05 ± 4.56E-05 V
		EMG_{ST} Rest	4.55E-06 ± 2.60E-06 V	3.98E-06 ± 2.50E-06 V
		EMG_{ST} Ratio	4.38E+07 ± 3.68E+07	2.71E+07 ± 1.23E+07

CMJ: Countermovement jump. EMG: Electromyography. ST: Semitendinosus. Ratio: peak/rest.

Wilcoxon showed non-statistical significance difference for the SJ EMG_{RF} in the LL dominance comparison for the DCN ($Z_{-0.169}$, $P=0.469$) (average ± sd: D 8.38 μV ± 4.97 and nD 8.73 ± 5.87). Similarly, results were not statistically significant for the NN ($Z_{-1.153}$, $P=0.137$) (average ± sd: D 8.07 ± 5.97 and nD 6.87 ± 4.3). Mann-Whitney U tests showed no statistically significant difference for SJ EMG_{RF} between the groups neither for the nD LL ($Z_{-0.540}$, $P=0.310$) with a mean rank score of 13.71 for DCN and 12.00 for NN nor for the D LL ($Z_{0.001}$, $P=0.512$) with a mean rank score of 12.50 for DCN and 12.50 for NN. SJ EMG_{RF} values at the peak, rest and ratio are presented in Table 20.

Table 20: SJ EMG_{RF} Peak, Rest and Ratio (average ± standard deviation)

			Dancers	Non-dancers
SJ	Dominant	EMG_{RF} Peak	2.04E-04 ± 8.04E-05 V	4.59E-04 ± 1.07E-03 V
		EMG_{RF} Rest	2.55E-06 ± 5.54E-07 V	4.19E-06 ± 4.77E-06 V
		EMG_{RF} Ratio	8.73E+07 ± 4.88E+07	8.38E+07 ± 5.95E+07
	Non-dominant	EMG_{RF} Peak	2.37E-04 ± 1.37E-04 V	2.11E-04 ± 1.90E-04 V
		EMG_{RF} Rest	3.05E-06 ± 1.16E-06 V	4.97E-06 ± 7.74E-06 V

		EMG_{RF} Ratio	8.66E+07 ± 4.14E+07	6.47E+07 ± 4.22E+07
--	--	-------------------------------	---------------------	---------------------

SJ: Squat jump. EMG: Electromyography. RF: Rectus femoris. Ratio: peak/rest.

Wilcoxon showed non-statistical significance difference for the SJ EMG_{ST} in the LL dominance comparison for the DCN ($Z_{-1.183}$, $P=0.148$) (average ± sd: D 1.56 ± 1.54 and nD 3.14 ± 2.05). Similarly, results were not statistically significant for the NN ($Z_{-0.314}$, $P=0.396$) (average ± sd: D 3.66 ± 2.07 and nD 3.44 ± 2.67). Mann-Whitney U tests showed a statistically significant difference for SJ EMG_{ST} between the groups for the D LL ($Z_{-2.756}$, $P=0.002$) with a mean rank score of 6.88 for DCN and 15.31 for NN. No difference was found between the groups for the nD LL ($Z_{0.001}$, $P=0.513$) with a mean rank score of 12.00 for DCN and 12.00 for NN. SJ EMG_{ST} values at the peak, rest and ratio are presented in Table 21.

Table 21: SJ EMG_{ST} Peak, Rest and Ratio (average ± standard deviation)

			Dancers	Non-dancers
SJ	Dominant	EMG_{ST} Peak	3.55E-05 ± 9.20E-06 V	1.60E-04 ± 1.34E-04 V
		EMG_{ST} Rest	4.21E-06 ± 2.35E-06 V	4.37E-06 ± 2.48E-06 V
		EMG_{ST} Ratio	1.04E+07 ± 4.89E+06	3.55E+07 ± 2.03E+07
	Non-dominant	EMG_{ST} Peak	7.76E-05 ± 4.75E-05 V	1.39E-04 ± 1.19E-04 V
		EMG_{ST} Rest	3.06E-06 ± 8.77E-07 V	3.83E-06 ± 1.71E-06 V
		EMG_{ST} Ratio	2.66E+07 ± 1.70E+07	3.88E+07 ± 2.54E+07

SJ: Squat jump. EMG: Electromyography. ST: Semitendinosus. Ratio: peak/rest.

5.4.5 MTU structural characteristics: Lower limb dominance and group comparisons

No main effect of LL dominance ($F_{0.620}$ $P=0.438$; $\eta^2_p=0.022$; $\beta=0.12$) nor main effect of group ($F_{0.696}$ $P=0.411$; $\eta^2_p=0.024$; $\beta=0.28$) was found for CSA. In addition, no interaction (group [DCN and NN] x LL dominance [D and nD]) was observed ($F_{4.208}$ $P=0.05$; $\eta^2_p=0.131$; $\beta=0.508$) for CSA.

No main effect of LL dominance ($F_{0.766}$ $P=0.389$; $\eta^2_p=0.028$; $\beta=0.135$) nor main effect of group ($F_{0.788}$ $P=0.788$; $\eta^2_p=0.003$; $\beta=0.058$) was found for fat thickness. In addition, no interaction (group [DCN and NN] x LL dominance [D and nD]) was observed ($F_{0.656}$ $P=0.425$; $\eta^2_p=0.024$; $\beta=0.122$) for fat thickness.

Mann-Whitney U tests showed no statistically significant difference in the semitendinosus thickness between the DCN and NN ($Z_{-0.264}$, $P=0.402$) groups with a mean rank score of 16.10 for DCN and 15.32 for NN. Wilcoxon showed non-statistical significance difference for the

semitendinosus thickness in the LL dominance comparison for the NN ($Z_{-0.282}$, $P=0.399$) (average \pm sd: D 2.10 ± 0.39 and nD 2.12 ± 0.56) nor for the DCN ($Z_{-0.764}$, $P=0.246$) (average \pm sd: D 2.16 ± 0.49 and nD 2.04 ± 0.38).

No main effect of LL dominance ($F_{3.137}$ $P=0.088$; $\eta^2_p=0.104$; $\beta=0.401$) nor main effect of group ($F_{0.191}$ $P=0.666$; $\eta^2_p=0.007$; $\beta=0.071$) was found for total lean tissue thickness. Thus, no interaction (group [DCN and NN] x LL dominance [D and nD]) was observed ($F_{1.253}$ $P=0.273$; $\eta^2_p=0.044$; $\beta=0.191$) for total lean.

Mann-Whitney U tests showed no statistically significant difference in the muscle width between the DCN and NN ($Z_{-0.252}$, $P=0.407$) with a mean rank score of 15.44 for DCN and 14.80 for NN. Wilcoxon showed non-statistical significance difference for the muscle width in the LL dominance comparison for the NN DCN ($Z_{-0.392}$, $P=0.365$) (average \pm sd: D 3.67 ± 0.79 and nD 3.66 ± 0.91) nor for DCN ($Z_{-1.225}$, $P=0.125$) (average \pm sd: D 3.75 ± 0.88 and nD 3.67 ± 0.80).

No main effect of LL dominance ($F_{1.647}$ $P=0.210$; $\eta^2_p=0.056$; $\beta=0.236$) was found but a main effect of group ($F_{13.147}$ $P=0.001$; $\eta^2_p=0.320$; $\beta=0.93$) was found for muscle length. Muscle length was greater in the NN compared to the DCN group (collapsed means across conditions; $41.47 \text{ cm} \pm 0.44$ and $38.70 \text{ cm} \pm 0.62$ respectively, $P<0.01$). An interaction (group [DCN and NN] x LL dominance [D and nD]) was observed ($F_{4.575}$ $P=0.041$; $\eta^2_p=0.140$; $\beta=0.542$) for muscle length.

5.4.6 Lower limb dominance and group comparisons: general pain and pain coping strategies

In brief, there is no difference in pain sensation and coping strategies in any of the tests assessed in the pain mix-method. Results are presented in Tables 22 to 25 and Figure 38.

Table 22: Unpaired t-tests comparing Dancers and Non-dancers for the Pain Anxiety Symptom Scale (PASS)

	Group	Average	SD	<i>P</i>
Total PASS score	Non-dancers	37.31	16.20	0.925
	Dancers	36.70	17.34	
Mode PASS score	Non-dancers	1.68	1.33	0.717
	Dancers	1.50	1.17	
PASS cog anx	Non-dancers	9.00	5.15	0.919
	Dancers	9.20	4.54	
PASS escape	Non-dancers	9.26	5.11	0.984
	Dancers	9.30	4.05	

PASS fear	Non-dancers	10.31	3.74	0.706
	Dancers	9.70	4.83	
PASS physio	Non-dancers	8.73	3.64	0.891
	Dancers	8.50	4.69	

P: significance level, *sd*: standard deviation, PASS: Pain Anxiety Symptom Scale, Cog: Cognitive, Anx: anxiety, Physio: Physiologic.

Table 23: Mann-Whitney comparing Dancers and Non-dancers for the Self-Estimated Functional Inability because of Pain (SEFIP)

	Z	P		Z	P
Neck	0.000	1.000	Wrists Hand	-1.800	0.245
Upper back	-0.134	0.944	Thigh Front	-0.509	0.724
Elbow	-0.745	0.832	Knee	-0.268	0.869
Lower Back	-0.706	0.524	Shin	-0.134	0.944
Hips	-0.394	0.832	Calf	-0.550	0.690
Thigh Back	-1.058	0.408	Ankle Feet	-0.788	0.654
Shoulder	-1.612	0.226	Toes	-0.745	0.832

Table 24: Mann-Whitney comparing Dancers and Non-dancers for the Self-Estimated Functional Inability because of Pain total scores (SEFIP) and Ice Water Test (IWT) total time.

	Total SEFIP	Mode SEFIP	Time tolerated
Z	-0.436	-1.074	-1.518
Sig.	0.689	0.654	0.143

Table 25: Descriptive statistics of the Visual Analogue Scale (VAS) of pain rated during the Ice Water Test

	Group	N	Mean	Std. Deviation
VAS0s	Non-dancers	20	3.6000	2.39297
	Dancers	10	4.8000	2.44040
VAS15s	Non-dancers	20	6.2000	2.44088
	Dancers	10	6.7000	1.63639
VAS30s	Non-dancers	17	7.4118	2.57534
	Dancers	9	7.6667	1.22474
VAS45s	Non-dancers	10	6.8000	2.78089
	Dancers	8	7.8750	1.45774
VAS60s	Non-dancers	7	6.8571	2.54484
	Dancers	5	8.0000	1.87083
VAS75s	Non-dancers	6	7.1667	3.37145
	Dancers	4	7.2500	1.70783
VAS90s	Non-dancers	6	7.3333	3.20416
	Dancers	4	7.5000	1.91485
VAS105s	Non-dancers	6	7.1667	2.85774
	Dancers	4	7.5000	1.91485
VAS120s	Non-dancers	6	7.0000	2.75681
	Dancers	4	8.0000	2.16025

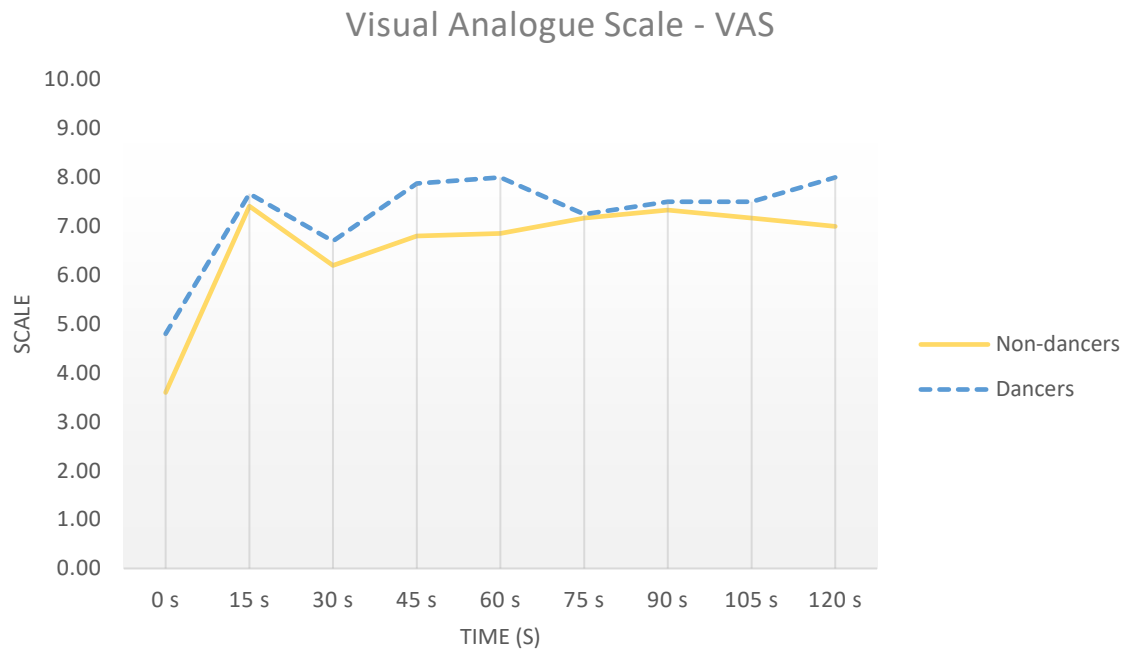

Figure 38: Visual analogue scale comparison between groups.

5.4.7 Presence of hormone levels as a covariate in the MTU structure, function and performance

Table 26 summarises the hormonal concentration of female hormones in both groups and per group.

Table 26: Hormone concentration (average \pm standard deviation)

	CV (%)	Concentration total	Concentration per group
Serum Oestrogen	5.91 \pm 4.78	162.61 \pm 141.53 pg/ml	NN 128.62 \pm 116.07 pg/ml DCN 215.49 \pm 167.41 pg/ml
Serum Progesterone	17.35 \pm 26.99	9.74 \pm 2.21 ng/ml	NN 9.67 \pm 1.86 ng/ml DCN 9.36 \pm 3.39 ng/ml
Serum Relaxin	2.81 \pm 2.39	0.73 \pm 0.57 pg/ml	NN 0.79 \pm 0.70 pg/ml DCN 0.65 \pm 0.30 pg/ml

CV: coefficient of variation, NN: non-dancers, DCN: dancers.

Unpaired t-tests showed a non-significant difference in progesterone ($P=0.749$) concentrations between the DCN and NN groups. Similarly, Mann-Whitney U tests showed a non-significant difference neither in relaxin ($P=0.507$) nor in oestrogen ($P=0.064$) concentrations between the groups.

Notwithstanding the lack of group differences in hormones levels, previous research made it pertinent to determine whether these hormones were a covariate in our analyses. This

further data mining would be expected to increase the precision of our analyses, should corrections be required. This mining was carried out by running a series of bivariate correlations between outcome measures that were significantly different between dancers and non-dancers, against these hormones. Table 27 shows only the significant³⁰ correlation between the hormone concentrations and dependent variables.

Table 27: Hormone concentration and dependent variables correlations

	Oestrogen	Progesterone	Relaxin
ROM _{Max}	$P = 0.012$ $r = 0.297^*$	$P = 0.038$ $r = 0.234^*$	-
Torque _{Max}	$P = 0.043$ $r = 0.227^*$	$P = 0.007$ $r = 0.320^{**}$	-
FSS _{ROM}	$P = 0.001$ $r = 0.390^{**}$	-	-
S _{MTU}	$P = 0.028$ $r = 0.253^*$	-	-
Energy	$P = 0.002$ $r = 0.378^{**}$	$P = 0.030$ $r = 0.249^*$	-
SJ Total Force _{peak}	-	-	$P = 0.035$ $r = 0.385^*$
PASS Escape	-	$P = 0.029$ $r = 0.362^*$	-

ROM: Range of motion. Max: Maximal. FSS: First sensation of stretch. MTU: Muscle tendon unit. SJ: Squat jump. PASS: Pain Anxiety Symptom Scale. P = significant correlation. * = $P < 0.05$. ** = $P < 0.001$. r = correlation. -: not relevant analysis.

A one-way ANCOVA was conducted to compare the aforementioned variables between the groups whilst controlling for Oestrogen, Progesterone and Relaxin hormonal concentrations when appropriate. Although bivariate correlations showed the hormones as a covariate, the ANCOVA (Table 28) showed non-significance for covariances for the same variables. Enhancing the validity of the previous ANOVA results.

Table 28: Univariate ANCOVA

	Oestrogen	Progesterone	Relaxin
ROM _{Max}	$P = 0.949$	$P = 0.759$	-
Torque _{Max}	$P = 0.736$	$P = 0.508$	-
FSS _{ROM}	$P = 0.221$	-	-
S _{MTU}	$P = 0.235$	-	-
Energy	$P = 0.756$	$P = 0.459$	-
SJ Total Force _{peak}	-	-	$P = 0.087$
PASS Escape	-	$P = 0.108$	-

ROM: Range of motion. Max: Maximal. FSS: First sensation of stretch. S_{MTU}: Muscle-tendon unit stiffness. SJ: Squat jump. PASS: Pain Anxiety Symptom Scale. P: Significance level. -: not relevant analysis.

5.5 Discussion

The first aim of this study was to compare the functional and structural characteristics of the MTU between dancers and non-dancers. The flexibility and jump capacities were examined along with muscle architecture and hormonal concentration to characterise and compare

³⁰ See complete table Appendix G pages 285

these populations. Additionally, comparisons between the lower limbs were performed to highlight any possible asymmetries. It was hypothesised that dancers would present different characteristics from non-dancers, given that both flexibility and jump movements are crucial for dancing and that the practice of distinct exercise modalities may uniquely affect the body (Karloh et al., 2010, Alencar and Matias, 2010), therefore, muscle structural differences were also expected due to the practice of these capacities. Only four variables related to the flexibility (ROM_{Max} , $torque_{Max}$, FSS_{ROM} and energy), one variable related to jumping (SJ total force_{peak}) and the SJ EMG_{RF} (only in the comparison of the dominant lower limb between groups) were statistically different between the groups, partially rejecting the null hypothesis. However, the null hypothesis was not rejected for the structural variables, jump variables, pain mix method and hormonal concentration of female hormones.

The ROM_{Max} , $torque_{Max}$, FSS_{ROM} and energy were found to be significantly different between groups, corroborating previous research that found differences in flexibility between dancers and non-dancers (Pessali-Marques, 2015). The ROM_{Max} was greater for the dancers compared to non-dancers either for the D and nD limbs (average \pm sd ($^{\circ}$): DCN D = 135.5 ± 14.2 ; NN D = 104.2 ± 18.0 ; DCN nD = 130.8 ± 14.1 ; NN nD = 99.4 ± 17.8) indicating that the training of different dance modalities, which require flexibility, may improve the ROM_{Max} (Janyachoen et al., 2013, Hui et al., 2009, Hopkins et al., 1990, Alricsson et al., 2003). Considering that the ROM_{Max} increase is dependent of the quantity of applied torque (Weppeler and Magnusson, 2010), it was expected that the population with greater values of ROM_{Max} would also present greater values of $torque_{Max}$. Accordingly, the dancers showed statistically greater values of $torque_{Max}$ for both limbs when compared to non-dancers (average \pm sd (N.m): DCN D = 139.2 ± 37.1 ; NN D = 95.5 ± 35.0 ; DCN nD = 147.3 ± 32.3 ; NN nD = 92.9 ± 35.7). However, although differences between the limbs were found for ROM_{Max} , no differences were found for the $torque_{Max}$, indicating possible biomechanical differences between the limbs.

The interpretation of the $torque_{Max}$ and the FSS_{torque} data may provide information about stretch tolerance. In both situations, the torque exerted on the MTU may trigger the mechanoreceptors responsible for the pain sensation (Avela et al., 1999). The FSS_{torque} would indicate the beginning of the discomfort while the $torque_{Max}$ would indicate the maximal

pain tolerated during stretching. Dancers tolerated greater values of $\text{torque}_{\text{Max}}$ substantiating (Blazevich et al., 2012) who also found a greater $\text{torque}_{\text{Max}}$ for more flexible participants compared to less flexible counterparts. Following this line of thought, it was expected that dancers would also tolerate more torque at the beginning of the stretch due to the greater tolerance. However, dancers signalled the initial discomfort at a similar value of torque ($\text{FSS}_{\text{torque}}$) compared to non-dancers, suggesting that although dancers tolerate a greater maximal pain, the beginning of the stretching discomfort occurred is a constant regardless of maximal ability.

Additionally, the FSS_{ROM} was greater for the dancers than the non-dancers, indicating that for a similar torque, dancers reached greater ROM, also corroborating previous authors (Blazevich et al., 2012). These results partially contradict other research that also found no differences in the $\text{FSS}_{\text{torque}}$ between dancers and non-dancers, but a smaller FSS_{ROM} for dancers compared to non-dancers (Pessali-Marques, 2015). (Pessali-Marques, 2015), however, compared the groups after the stretch intervention, while the present study did not apply any stretching protocol. The greater FSS_{ROM} for same $\text{FSS}_{\text{torque}}$ in dancers could be explained by a difference in S_{MTU} , in which dancers would present smaller values. However, S_{MTU} was not different between the groups in the current research, nor in (Pessali-Marques, 2015) study. (Pessali-Marques, 2015), did not find a difference in the $\text{torque}_{\text{ROM}}$ between the groups (variable used to represent the biomechanical modifications of the tissue, calculated by the variation of ROM for a same value of torque) (Hutton, 1992), (Herda et al., 2011a), indicating that no biomechanical modification differences were found to justify the greater increase in the ROM_{Max} after the intervention. The author concluded that other mechanisms, such as the stretch tolerance, rather than biomechanical modifications, may have played a role in the ROM increase.

The lack of difference in the S_{MTU} between dancers and non-dancers contradicts previous research comparing more and less flexible participants, which found that stiffer participants are also less flexible, with lower stretch tolerance and smaller S_{MTU} in the ROM_{Max} (Magnusson et al., 1997, Blazevich et al., 2012). However, the fact that more flexible participants tolerate a greater $\text{torque}_{\text{Max}}$ (Blazevich et al., 2012) corroborates the current study findings. Additionally, a smaller H-reflex in dancers compared to other athletes and

sedentary adults (Nielsen et al., 1993) and a smaller half-relaxation time for a mechanical stimulus in the tendon for dancers compared to non-dancers, reinforce the idea of lower S_{MTU} in dancers. The previous studies, however, were performed with professional dancers, while the current research evaluated student dancers. The non-difference in the S_{MTU} between the limbs, however, justify the non-difference in the energy also between the limbs.

Despite the modification in the maximal tolerance found through the torque_{Max} in the current and previous research (Pessali-Marques, 2015, Pessali-Marques et al., 2015, Cabido et al., 2014), which may provide a clue about the pain tolerance during the stretch, none of the studies explained the possible mechanisms related to this difference. Due to the subjectivity of pain experiences (Gracely, 2006, Edwards, 2005, Khan and Stroman, 2015, Slepian et al., 2017, France et al., 2002, Drahozal et al., 2006, Kamping et al., 2016) to consider the contribution of psychological factors may help to understand the differences in pain perception. Therefore, the IWT and questionnaires of coping strategies to pain were further applied in the current research to provide information about any differences in pain tolerance. No significant differences were found, however, either in the general discomfort to the IWT or in any of the scales of the PASS. One possible explanation might be due to the similarity between the populations gathered in the present research; dance students were compared to sport science students, who were also active in a different type of sports, such as volleyball, football, netball, weight lift among others (see Tables 11 and 12 page 101). Both dancers and athletes from different sport modalities have previously been found to have higher pain tolerance compared to sedentary groups (Azevedo and Samulski, 2003). The studies that found a difference in pain tolerance between dancers and non-dancers compared professional dancers to sedentary people (Tajet-Foxell and Rose, 1995). While sedentary people are not familiar with discomforts caused by training, dancers/athletes have the willpower to enhance performance, frequently at any cost, accepting and minimizing the pain (Weinberg et al., 2013), which may affect the pain modulation strategies. Therefore, to understand possible coping strategies, studies should compare dancers (especially professional levels) with truly sedentary populations.

The anthropometric data and habitual exercise volume similarity between the groups may have also affected other variables measured in the current research, such as the jump and structural characteristics of the muscles. The comparison of the structural characteristics of the MTU showed no significant differences in any of the measured variables: semitendinosus CSA, fat thickness, total lean and muscle width between dancers and non-dancers. Only the muscle length differed between the two groups. However, the measurements of muscle length were taken using the bone markers³¹, therefore, this result indicates an anthropometric difference rather than a muscle structural difference between the groups. Although (Magnusson et al., 1997) found differences in the flexibility between more and less flexible participants, the authors also did not find differences in the cross-sectional area among the participants. No studies comparing the structural MTU characteristics of dancers and non-dancers, in the best of the author's knowledge, were found.

Regarding the jump variables, only the SJ total force_{peak} was different between the groups. The lack of a difference between the dancers and non-dancers might be due to the fact that the non-dancers also practised modalities that require jump capacity, such as football, volleyball, netball, among others. Considering also that there were no muscle structural differences between the groups, the chances of finding functional differences were limited. The difference in the SJ total force_{peak} could be related to the difference in S_{MTU} between the groups, which may affect the load transference for a similar mechanical stimulus (Koceja et al., 1991), ultimately impacting the muscle shortening velocity and affecting the force-production capacity. However, no difference in the S_{MTU} was found.

The second aim of this study was to compare the dominant and non-dominant lower limbs within the groups. Concerning the flexibility variables, only the ROM_{Max} was found to be statistically different between the dominant and non-dominant limbs rejecting the null hypothesis. Furthermore, none of the structural variables was statistically different between the limbs. However, for the jump, the alternative hypothesis was partially confirmed. The CMJ force_{peak}, force_{Max} and impulse, and the SJ force_{peak} and force_{Max} were greater in the dominant limb compared to the non-dominant limb for the dancers, while CMJ force_{peak} and

³¹ Vide Overall Methods section 3.3.6 page 69

CMJ force_{Max} only were greater, also in the dominant limb, for the non-dancers. However, these differences were not related to S_{MTU}, as we had hypothesized.

Some studies suggested that possible asymmetries between the limbs may be due to a greater amount of dance practice for the favourite side (Kimmerle and Science, 2010). Although no differences in the quantity of asymmetry, between the limbs, was found comparing the ROM_{Max} difference between the groups, dancers showed more asymmetries in the vertical jump than the non-dancers, probably due to the ROM difference. Due to the small sample size, especially for the DCN, increasing the sample size would be paramount to confirm these results. These findings corroborate previous studies indicating that, although a level of asymmetries is naturally acquired in everyday motion (Herzog et al., 1989), the practice of dance may increase asymmetries (Kimmerle and Science, 2010) between the limbs, and, contradict other studies that suggested that dance is a bilateral activity (Herzog et al., 1989). In the results of the current thesis, in one instance, although differences in between the lower limbs for the flexibility variables were found, they were not greater than the differences also found for the non-dancers' group. (Kadel et al., 2005) found no differences between the left and right leg ROM in the hamstrings of young ballet dancers (10.4 ± 1.2 years old) while (Davenport et al., 2016) found an imbalance of 10° in the adductors of young adult dancers (20.8 ± 1.8 years old) who reported prior injuries. It is difficult to compare these studies with the results of the current research, however, since the ages and muscles are different. An age-related decrease in flexibility is caused by biological changes such as tendon stiffening, joint capsule changes, or muscle changes (Sands, 1990, Gajdosik et al., 1999). Goldspink and Harridge (1992) demonstrated that with age, collagen increases in solubility becomes more cross-linked, and increases in content in the muscle, leading to decreases in ROM.

Considering that torque_{Max} is expected to increase with the increase of the ROM_{Max}, it was expected that the limb with greater ROM_{Max} would also present greater torque_{Max} in a similar manner to what was observed in the results comparing the ROM_{Max} and torque_{Max} between the groups. However, although the ROM_{Max} was different, no differences were found in the torque_{Max} between the limbs. One possible explanation might be due to the fact that the resistance torque resulting from the muscle deformation during the stretching is monitored

by mechanoreceptors (Avela et al., 1999), therefore, the necessary torque to stimulate these mechanoreceptors could be considered a mechanical threshold for the stretch pain. These mechanoreceptors are tension stimulated, therefore, the same tension, independently of the respective ROM, would discharge the neural signal of pain, determining the maximal ROM achieved. Given that both limbs are under the control of the central nervous system of the same individual, the same stimuli would result in similar sensory behaviour, even though the biomechanical behaviour is different between the limbs. Only a few studies have studied the stretch tolerance modification and the sensory property of the MTU to stretching (Chagas et al., 2016, Pessali-Marques, 2015, Cabido et al., 2014). Despite the modification in the tolerance found, none of the aforementioned studies explained the possible mechanisms related to this difference, therefore, further studies are necessary to reveal these mechanisms. Accordingly, a possible explanation for the difference in the ROM_{Max} but the non-difference in the $torque_{Max}$ comparing the limbs could be due to the biomechanical properties of the tissue. However, S_{MTU} was not different between the limbs, not explaining why limbs with the same $torque_{Max}$ would achieve different ROM_{Max} .

Differences in many vertical jumps (CMJ and SJ) variables were found between the D and nD lower limbs for both groups, but mainly for the dancers, contradicting the non-difference in the biomechanical characteristics of the MTU found. Contrary to the hypothesis raised in this chapter that the D (most flexible) limb would exert less strength than the nD (less flexible) limb, Dancers' D lower limb was shown to perform greater CMJ $force_{peak}$, CMJ impulse and SJ $force_{peak}$, while the non-dancers' D lower limb presented greater CMJ $force_{peak}$ only. It is, however, a puzzle why the most flexible limb would also be the stronger one. One possible explanation could be due to the increase in the temperature, which was found to impact cross-bridge mechanics. It has been previously suggested that an increase of 3-4°C would be necessary to increase the extensibility of the tissue (Prentice, 2009). Nonetheless, (Magnusson et al., 2000) did not find a modification in the MTU mechanics after 3°C of internal temperature increased obtained through a warm-up on the treadmill. By any means, foreseeing any possible interference of temperature in the MTU structure, both limbs underwent the same stimuli, being always stretched after the same CMJ and SJ jump routine and the room temperature was controlled and maintained constant at 20°C.

Another alternative could be through continued specific dance training, which requires dancers to perform always the maximal ROM during the movements and often sustaining isometrically in this elongated position (such as the *developpes* movement). The limb used to perform strength always in the greatest ROM possible (i.e. in a stretched position), would change the optimal working range of the sarcomeres in according to the maximal ROM of each limb. This would happen because of the cross-bridges working length distance (owing to the movement of the myosin head) and a stretchable neck which allows them to switch from high force to low force state, therefore, dance training may increase the compliance of the cross-bridges as well as the number of high force states being, thus, in longer length to retain the position on ascending limb/plateau of the F-L relationship. Corroborating this assumption, (Eston et al., 2007) highlighted evidence that the optimal angle for force production in more flexible muscles occurs at a longer muscle length when compared to less flexible muscles. (Marginson et al., 2005) compared boys and men and observed that the passive flexibility of the quadriceps muscle was significantly greater in boys compared with men. In addition, a shift to the right in the torque-joint angle curve of the knee extensors was found in the boy's group, meaning that the peak torque occurred at a higher joint angle (longer muscle length) in children than adults (Marginson and Eston, 2001). Boys also presented a greater ability to produce greater relative strength than the men at long muscle lengths, possibly leading to less overextension of sarcomeres during the damaging exercise bouts (Marginson et al., 2005). These results could be indicative of more sarcomeres in series in the most flexible limb. However, the number of sarcomeres was not measured in the current study and no studies, in the best of the author's knowledge, were found comparing limbs with different flexibility levels.

Regarding the muscle activation, non-dancers showed greater CMJ EMG_{RF} in the dominant lower limb than in the non-dominant. This greater activation of the rectus femoris in the most flexible limb may occur to compensate the greater length of the hamstrings from the same limb. The non-difference between the limbs in the CMJ and SJ EMG_{ST} suggests that, although the limbs presented different ROM_{Max} , the $torque_{Max}$ was not different between the limbs, therefore, the EMG, which is related to the passive extensibility of the tissues under stretch (i.e. an elongation of the tendon-aponeurosis complex and muscle fascicles during the passive stretch) (Avela et al., 1999) was also not different between the limbs. It

is important to highlight that the EMG appears to be related with the torque and not with the ROM.

Finally, the hormonal concentration of progesterone, oestrogen and relaxin assessed in the ovulatory phase was compared between the groups aiming to find any co-variances. No differences were found in the comparison of the hormone concentrations between the dancers and non-dancers, suggesting that any group difference was mechanically led, as opposed to endocrinologically-associated. A series of bivariate correlations between outcome measures that were significantly different between dancers and non-dancers were carried out against these hormones expecting to increase the precision of our analyses. Although some variables were showed to be correlated with the hormonal levels, further ANCOVA analysis aiming to correct the dependent variables against the hormonal concentration negated any hormone covariance, confirming previous ANOVA results.

5.6 Conclusion

The results of this study showed differences only in the ROM_{Max} , $torque_{Max}$, FSS_{ROM} , Energy, flexibility related variables, between dancers and non-dancers. However, no conclusions about the mechanisms to explain these differences were achieved, given that no further differences in the remaining flexibility variables were found, nor in the structural muscle characteristics, as well as in the vertical jump performance and pain. Further research comparing more distinct populations, such as sedentary people and professional dancers, are necessary to highlight the reasons dancers have higher maximal tolerance but similar tolerance at the beginning of the stretch and no differences in the general pain and coping strategies, as well as greater FSS_{ROM} but similar S_{MTU} . The necessity of deeper comprehension about these mechanisms is highlighted by the fact that similar differences were found in between the limbs, where the ROM was greater in the dominant limb, but no sensory or biomechanical differences were found to justify this difference neither in the structural characteristics and jump performance.

Chapter 3: Impact of an acute stretch intervention on lower limb asymmetries, functional characteristics of the MTU and vertical jump and flexibility performance in dancers under contraception

“É nos momentos mais obscuros que devemos focar para ver a luz”

Aristóteles

“It is during the darkest moments that we must focus to see the light.”

Aristoteles

6.1 Introduction

Stiffness (S_{MTU}) is a property of the muscle-tendon unit (MTU) commonly used to represent its biomechanical properties (Herda et al., 2011a, Ryan et al., 2008b) and its adaptation to stretching. It is calculated by the variation of the range of motion (ROM) divided by the variation of the torque (Latash and Zatsiorsky, 2015); therefore, it represents the resistance of the MTU against stretching (Fouré et al., 2011) and it is correlated to the MTU capacity of absorbing elastic potential energy (Marshall et al., 2011, Cabido et al., 2014, Blazevich et al., 2012). The S_{MTU} also affects the stretch-shortening cycle (SSC) and the capacity of force generation (Brughelli and Cronin, 2008b). During the SSC a stiffer MTU induces better transmission of the force via the tendon directly to the bone and shortens the coupling time between eccentric and concentric phases (Ochala et al., 2007b). An increased ligament stiffness would increase the initial muscle shortening velocity, the degree of muscle shortening, and the muscle fascicle pennation angle at rest and during contraction, ultimately affecting the force-production capacity (Ochala et al., 2007b).

Distinct decreases in S_{MTU} have previously been found after stretch interventions (Kubo et al., 2001a, Blackburn et al., 2004, Magnusson et al., 1997, Hutton, 1992, Herda et al., 2011a). Notwithstanding this, the reduction in the S_{MTU} was proven to be greater when the torque was maintained constant for a period (constant torque technique - CT) compared with when the angle was maintained constant (constant angle technique - CA) for a period (Cabido et al., 2014, Herda et al., 2011a, Yeh et al., 2005). This difference in the S_{MTU} decrease after the CT and CA stretch techniques highlight the influence of different stretch protocols on the same MTU mechanical property.

Comparisons between participants with different levels of flexibility have also previously shown differential S_{MTU} responses to the same stretch protocol. Indeed previous authors Magnusson et al. (1997) used the *toe-touch test* to divide their participants into two groups according to their S_{MTU} level: "tight" and "normal", with the stiffer participants forming the tight group. After an acute session of stretch (intervention), the authors found a smaller ROM_{Max} , less stretch tolerance and less S_{MTU} in the ROM_{Max} for the tight group compared to the normal group. Corroborating with these authors, other authors Blazevich et al. (2012) compared "more" and "less" flexible participants and found that, although a greater S_{MTU} is

expected for the more flexible participants at ROM_{Max} , the more-flexible group showed a smaller S_{MTU} for a comparable ROM. These studies, however, have examined the response of one limb only, and in populations for whom flexibility is not a fundamental capability. It is possible that different responses may be expected for populations who frequently train this capability, such as dancers (Pessali-Marques, 2015).

Even though dance is often considered a bilateral activity, dancers frequently train more on one side during rehearsals, which may generate asymmetries in flexibility and/or strength. Despite the fact that the definition of limb dominance in dance is not clear (Kimmerle and Science, 2010), the existence of a “preferred lower limb” sometimes referred as the “dominant limb” is suggested. This limb is usually chosen to perform voluntary and more technical movements (Sadeghi et al., 2000). Consequently, it is believed that this dominant limb would present greater values of ROM, which is important for the aesthetic component of dance movements (Angioi et al., 2009b) while the non-dominant limb, responsible for support and stabilisation of the body, would be the stronger of the two.

It is possible that the flexibility and/or strength training of one lower limb in detriment to the other, and/or asymmetries between the limbs, either inherent or caused by a specific exercise modality, may result in different ROM_{Max} , $torque_{Max}$ and consequently S_{MTU} in the limbs. Therefore, considering that differences in S_{MTU} for the same ROM have previously been found due to difference in the maximal ROM Blazeovich et al. (2012) and also owing to the possible asymmetry in flexibility between the lower limbs in dancers caused by disparity in the practice of the movements, the current chapter aimed to compare the S_{MTU} between the lower limbs and examine the performance in jumps and flexibility in dancer is affected by any level of asymmetry. Therefore, it was hypothesised that asymmetries in flexibility with consequential asymmetries in S_{MTU} between the lower limbs may cause differences in force production and thus affect performance in the jump.

6.2 Methods

6.2.1 Participants

Fifteen female undergraduate contemporary dance students comprised this study (mean [SD]: age 21 [7] years, body mass 63.22 [5.74] kg, height 1.61 [0.03] m, body fat 27.01 [2.77]

%) Ethics, inclusion and exclusion criteria are described in the Overall Methods³². All participants were taking either progesterone-only or combined (oestradiol and progesterone) birth contraception. 53.33% of participants were under progesterone only and 46.67% under combined birth contraception.

6.2.2 Procedures

Participants were tested on two separate days with 24 to a 48-hour interval between sessions. The familiarization³³ was performed in the first session and the tests on the second session (Figure 31). On the second session, participants arrived at the laboratory and anthropometry³⁴ measurements were performed for the characterisation of the population, 5 ml of salivary samples³⁵ were collected followed by the positioning of the electromyographic electrodes³⁶.

The vertical jump Pre-test³⁷ was performed followed by the flexibility Pre-test³⁸ identifying the leg with greater ROM further nominated Dominant leg (D). The intervention³⁹ was performed only in the most flexible lower limb, aiming to enhance any asymmetry in flexibility already existent. Immediately after the intervention, the passive flexibility Post-test was assessed in the trained limb (Figure 39). Participants then underwent first the Post-test for the CMJ and SJ, followed by the flexibility Post-test in the control (non-dominant nD) leg. The aim of this protocol was: i) to evaluate the acute effect of any modification in the S_{MTU} affecting jump performance and ii) to submit the control limb to the same condition twice, hence an idea of data reliability and/or normal variations in the measures of interest (Figure 40).

³² Vide Overall Methods section 3.1 and 3.2 page 53

³³ Vide Overall Methods section 3.3.13 page 78

³⁴ Vide Overall Methods section 3.3.12 page 78

³⁵ Vide Overall Methods section 3.3.3 page 60

³⁶ Vide Overall Methods section 3.3.8 page 73

³⁷ Vide Overall Methods section 3.3.7 page 72

³⁸ Vide Overall Methods section 3.3.5 page 66

³⁹ Vide Overall Methods section 3.3.5 page 66

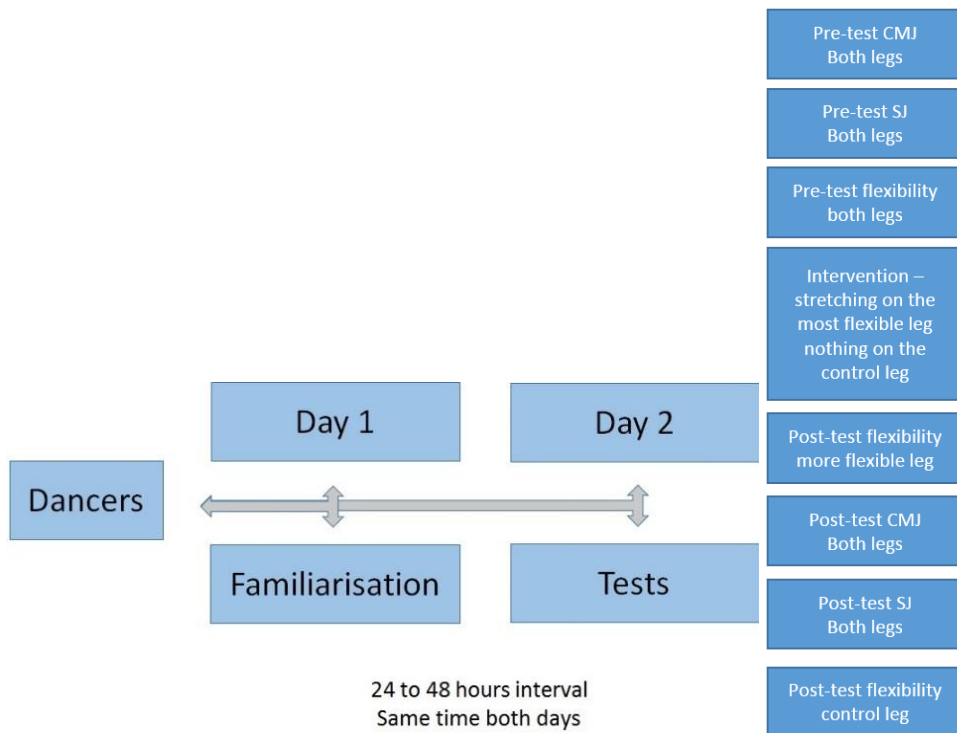

Figure 39: Illustrative figure of the procedures. CMJ: countermovement jump, SJ: squat jump. Most flexible leg = Intervention condition, Lest flexible leg = control condition.

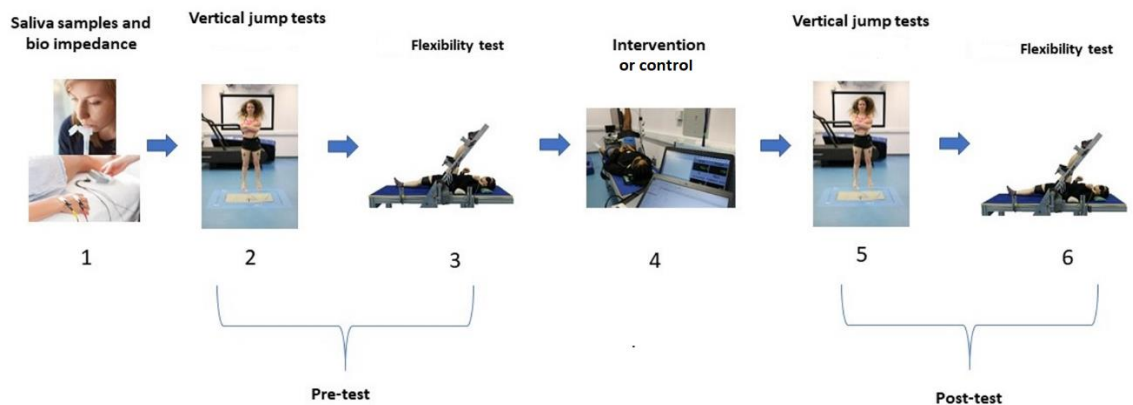

Figure 40: Illustrative figure of the tests' order (Photos: Bárbara Pessali-Marques)

6.2.3 Outcome variables

Variables summarised in Table 29 were collected in the Pre- and Post-test, with exception to hormone samples, which were collected once.

Table 29: Outcome variables Chapter 3

Flexibility	Vertical jump	Hormone
ROM _{Max} Torque _{Max} FSS _{ROM} FSS _{torque} SMTU Energy	Jump height Impulse Force _{peak} V _{Take-off}	Oestrogen and Progesterone (saliva)

ROM: Range of motion, Max: Maximal, FSS: first sensation of stretch, S: stiffness, MTU: muscle-tendon unit, V: velocity, SEFIP: Self-Estimated Functional Inability because of Pain, PASS: Pain Anxiety Symptom Scale, VAS: visual analogue scale, EMG: electromyography, RF: rectus femoris, ST: semitendinosus, CMJ: countermovement jump, SJ: squat jump, CSA: cross-sectional area.

6.3 Statistical Analyses

SPSS Statistics (v24 International Business Machines Corporation. New York. USA) was used for statistical analyses. Levene and Shapiro-Wilk statistic tests were performed to test the homogeneity of variance and the normality of the data, respectively. The comparison between control (C) and trained (T) lower limbs (condition), and Pre- and Post-test (time) for all the dependent variables was performed using the ANOVA repeated measures (when parametric) and the Friedman test (when non-parametric). Post hoc pairwise comparisons were performed, when necessary, to highlight any interaction. Paired t-tests were performed to compare the Pre- and Post-test between the combined legs (sum of D and nD limbs). A second analysis using the Paired t-tests was also performed to compare the relative change (i.e. delta %) between the Pre- and Post-tests ($[(DIF_{Post-Pre})/pre]$) for each variable between the groups (when parametric) and Mann-Whitney (when non-parametric). Finally, co-variance analyses (ANCOVA) were performed when necessary to factor out any hormonal influence on the dependent variables where appropriate. The statistical significance adopted was $\alpha \leq 0.05$, study power at $\beta \geq 0.8$ (and effect size $p\epsilon^2 \geq 0.2$ where study power was adequate). Descriptive statistics are presented as average \pm standard deviation (SD) (Table 16). The ROM_{Max} , $torque_{Max}$, FSS_{ROM} , FSS_{torque} and S_{MTU} intraclass correlation coefficients (ICC3.k) and the standard error of the measurements (SEM) were calculated using the data obtained in the control condition for the passive flexibility and jump (Weir et al., 2005). SEM was relativized by the average values of variables, resulting in percentage of SEM (SEM%) (Weir et al., 2005). ICC values were classified as weak (<0.4), moderate (0.4 to 0.59), good (0.6 to 0.74) and excellent (0.75 to 1.0) (Cicchetti, 1994).

6.4 Results

6.4.1 Parametricity checks

The characterisation of the DCT (dancer-contemporary-taking pill) is shown in Table 31 and the contraception status in Table 32. All variables presented a significance level > 0.05 for

the homogeneity test. All variable but the variables presented in Table 30 were normally distributed⁴⁰. The reliability of the data is presented in Table 10⁴¹.

Table 30: Non-parametric data – Shapiro Wilk

Variable	Group	<i>P</i>
Δ FSS _{ROM}	Training	0.001
Δ FSS _{torque}	Training	0.032
Δ S _{MTU}	Control	0.003
Δ Energy	Control	0.029
Pre - FSS _{ROM}	Training	0.002
Δ Peak force CMJ	Training	0.014
Pre – Take-off velocity SJ	Both legs	0.040

P: level of significance, Δ : delta, ROM: range of motion, S: stiffness, MTU: muscle tendon-unit, FSS: first sensation of stretch, CMJ: countermovement jump, SJ: squat jump.

Table 31: Characterisation of the participants (average \pm standard deviation)

	DCT
Age (years)	21.0 \pm 7.0
Height (m)	1.61 \pm 0.03
Body mass (kg)	65.83 \pm 5.74
Fat %	27.01 \pm 2.77
Fat (kg)	17.12 \pm 3.11
Lean %	72.97 \pm 2.77
Lean (kg)	45.75 \pm 3.01
Water %	50.45 \pm 3.06
Water (L)	31.67 \pm 1.81
Basal metabolism (j)	6395.14 \pm 303.67
Body mass index	23.85 \pm 1.84
Hours dancing per week	11.55 \pm 7.18
Hours practising other activity per week	4.25 \pm 3.87

DCT: Dancers – Contemporary – Taking contraception.

Table 32: Contraception status

Contraception	Number of participants
Intrauterine system	3
Combined pill	7
Progesterone only	5

6.4.2 MTU functional characteristics and flexibility performance after stretching: condition and time comparisons

A significant difference between condition (training and control) in the Pre-test and Post-test was found; the ROM_{Max} was greater for the T than for the C condition at both time points. A significant difference was also found between time points (Pre- and Post-test) in the C group ($P=0.001$), but no difference was found in the T condition ($P=0.741$) (average \pm

⁴⁰ See complete results of normality in the Appendix H page294.

⁴¹ See Results section Chapter 1 page 86

sd [°] - Pre-test: T = 132.20 ± 19.53, C = 118.46 ± 20.48; Post-test: T = 132.96 ± 19.03, C = 121.90 ± 21.68). A significant two-way interaction between condition (training and control) and time (Pre- and Post-test) was observed ($F_{22,969} P=0.001$; $\eta^2_p=0.621$; $\beta=1.00$) for ROM_{Max} (Figure 41).

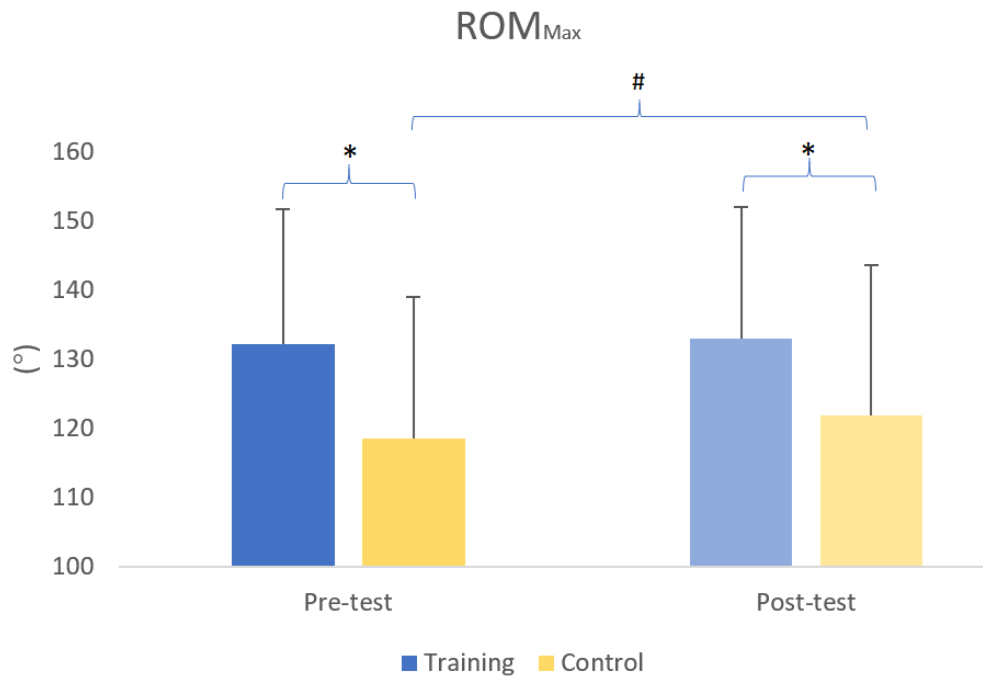

Figure 41: ROM_{Max} average and standard deviation for the comparisons between conditions: Training (T) x Control (C); and, time: Pre-test x Post-test. * statistical significance difference between the conditions. # statistical significance difference between time.

A significant difference between condition (training and control) in the Pre-test and the Post-test was found; torque_{Max} was greater for the T than for the C condition at both time points. No significant difference was found between time points (Pre- and Post-test) either for the C ($P=0.803$) or for the T ($P=0.755$) conditions (average ± sd [N.m] - Pre-test: T = 114.8 ± 49.1, C = 97.4 ± 42.1; Post-test: T = 112.9 ± 45.2, C = 98.8 ± 37.4). A significant two-way interaction for condition (training and control) and time (Pre- and Post-test) was observed ($F_{4,551} P=0.015$; $\eta^2_p=0.245$; $\beta=0.764$) for torque_{Max} (Figure 42).

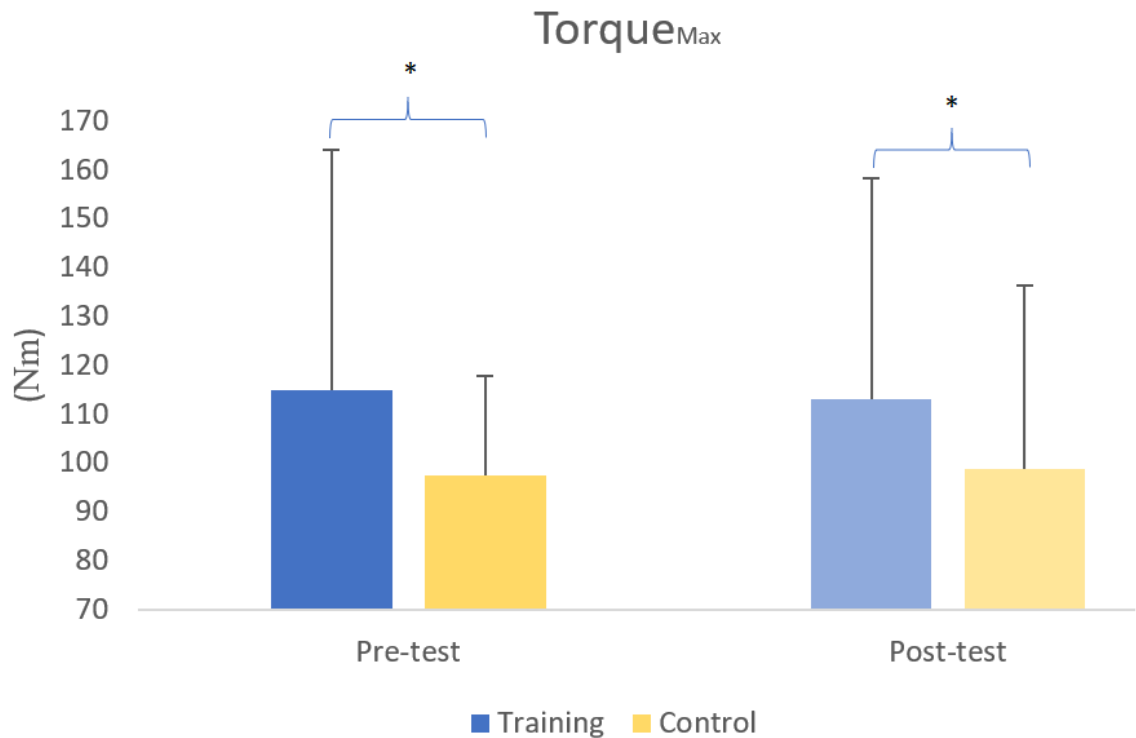

Figure 42: Torque_{Max} average and standard deviation for the comparisons between conditions: Training (T) x Control (C); and, time: Pre-test x Post-test. * statistical significance difference between the conditions. # statistical significance difference between time.

A non-significant difference between condition (training and control) in the Pre-test ($P=0.775$) and in the Post-test ($P=0.104$) was found FSS_{ROM}. In addition, no significant difference was found between time points (Pre- and Post-test) either for the C ($P=0.196$), or for the T ($P=0.128$) conditions (average \pm sd [$^{\circ}$] - Pre-test: T = 83.3 ± 23.2 , C = 85.4 ± 13.3 ; Post-test: T = 93.3 ± 13.2 , C = 88.2 ± 15.7). No significant two-way interaction for condition (training and control) or time (Pre- and Post-test) was observed ($F_{1,442}$ $P=0.255$; $\eta^2_p=0.093$; $\beta=0.234$) for FSS_{ROM}.

A non-significant difference between condition (training and control) in the Pre-test ($P=0.339$) and in the Post-test ($P=0.487$) was found for FSS_{torque}. In addition, no significant difference between time points (Pre- and Post-test) was found either for the C ($P=0.478$) or for the T ($P=0.268$) conditions (average \pm sd [N.m] - Pre-test: T = 35.6 ± 10.2 , C = 39.4 ± 17.7 ; Post-test: T = 39.1 ± 16.7 , C = 36.7 ± 13.8). No significant two-way interaction for condition (training and control) or time (Pre- and Post-test) was observed ($F_{0,582}$ $P=0.630$; $\eta^2_p=0.040$; $\beta=0.160$) for FSS_{torque}.

A non-significant difference between condition (training and control) in the Pre-test ($P=0.486$) and in the Post-test ($P=0.854$) was found for S_{MTU} . In addition, no significant difference between time points (Pre- and Post-test) was found either for the C ($P=0.656$) or for the T ($P=0.410$) conditions (average \pm sd - Pre-test: T = 0.84 ± 0.38 , C = 0.77 ± 0.41 ; Post-test: T = 0.81 ± 0.39 , C = 0.82 ± 0.42). No significant two-way interaction for condition (training and control) or time (Pre- and Post-test) was observed ($F_{0.226} P=0.878$; $\eta^2_p=0.017$; $\beta=0.089$) for S_{MTU} .

A non-significant difference between condition (training and control) in the Pre-test ($P=0.146$) and in the Post-test ($P=0.206$) was found for energy. In addition, no significant difference between time points (Pre- and Post-test) was found either for the C ($P=0.868$) or for the T ($P=0.960$) conditions (average \pm sd - Pre-test: T = 222.95 ± 94.54 , C = 191.40 ± 100.67 ; Post-test: T = 222.44 ± 108.31 , C = 194.10 ± 85.09). No significant two-way interaction for condition (training and control) or time (Pre- and Post-test) was observed ($F_{1.598} P=0.205$; $\eta^2_p=0.109$; $\beta=0.387$) for energy.

6.4.3 MTU functional characteristics and vertical jump performance after stretching: condition and time comparisons

A non-significant difference between condition (training and control) in the Pre-test ($P=0.888$) and in the Post-test ($P=0.339$) was found for CMJ Impulse. In addition, no significant difference between time points (Pre- and Post-test) was found either for the C ($P=0.339$) or for the T ($P=0.409$) conditions (average \pm sd [N.s] - Pre-test: T = 67.41 ± 23.61 , C = 69.63 ± 30.21 ; Post-test: T = 62.35 ± 14.75 , C = 72.43 ± 22.45). No significant two-way interaction for condition (training and control) or time (Pre- and Post-test) was observed ($F_{0.325} P=0.646$; $\eta^2_p=0.031$; $\beta=0.087$) for CMJ Impulse.

A non-significant difference between condition (training and control) in the Pre-test ($P=0.662$) and in the Post-test ($P=0.357$) was found CMJ force_{peak}. In addition, no significant difference between time points (Pre- and Post-test) was found either for the C ($P=0.288$) or for the T ($P=0.992$) condition (average \pm sd [N] - Pre-test: T = 338.71 ± 80.02 , C = 347.79 ± 501.16 ; Post-test: T = 339.03 ± 72.29 , C = 363.97 ± 60.19). No significant two-way interaction

for condition (training and control) or time (Pre- and Post-test) was observed ($F_{0.506} P=0.681$; $\eta^2_p=0.044$; $\beta=0.142$) for CMJ force_{peak}.

A non-significant difference between condition (training and control) in the Pre-test ($P=0.536$) and in the Post-test ($P=0.731$) was found for SJ impulse. In addition, no significant difference between time points (Pre- and Post-test) was found either for the C ($P=0.794$) or for the T ($P=0.960$) conditions (average \pm sd [N.s] - Pre-test: T = 58.35 ± 55.59 , C = 57.60 ± 80.15 ; Post-test: T = 77.95 ± 57.55 , C = 79.98 ± 88.42). No significant two-way interaction for condition (training and control) or time (Pre- and Post-test) was observed ($F_{0.213} P=0.695$; $\eta^2_p=0.017$ $\beta=0.073$) for SJ impulse.

A non-significant difference between condition (training and control) in the Pre-test ($P=0.089$) was found, but in the Post-test SJ force_{peak} was smaller in T than C ($P=0.018$) condition. In addition, SJ force_{peak} was significantly smaller for the C group ($P=0.032$) in the post-test in the comparison between time points (Pre- and Post-test) but it was not different for the T group ($P=0.05$) (average \pm sd [N] - Pre-test: T = 375.37 ± 97.10 , C = 408.78 ± 90.21 ; Post-test: T = 333.72 ± 55.08 , C = 380.09 ± 63.63). A significant two-way interaction for condition (training and control) or time (Pre- and Post-test) was observed ($F_{5.556} P=0.010$; $\eta^2_p=0.316$; $\beta=0.815$) for SJ force_{peak} (Figure 43).

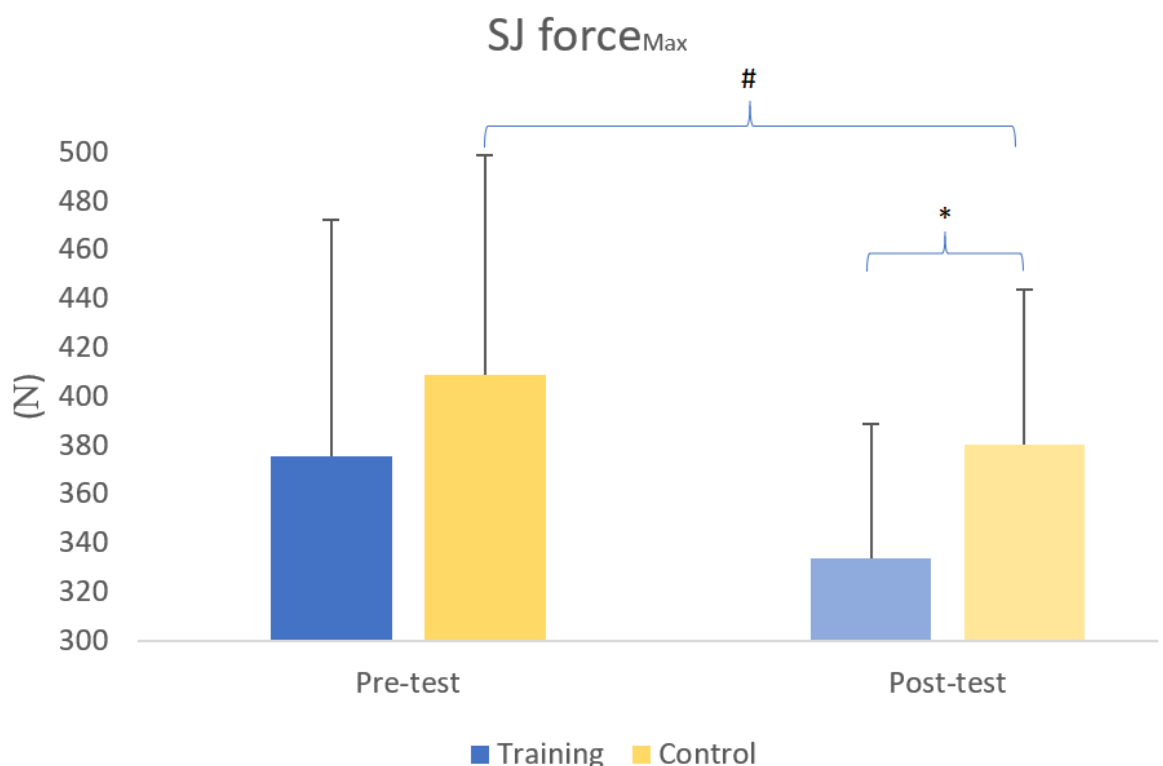

Figure 43: SJ force_{peak} average and standard deviation for the comparisons between conditions: Training (T) x Control (C); and, time: Pre-test x Post-test. * statistical significance difference between the conditions. # statistical significance difference between time.

6.4.4 MTU functional characteristics and jump performance: Pre- and Post-test comparisons

Paired t- and Mann-Whitney U tests were conducted to compare the dependent variables of combined limbs (total = sum of D-intervention and nD-control limbs) between the Pre- and Post-test. None of the CMJ variables presented statistic differences between the time points (Table 33).

Table 33: Paired t-tests (when parametric) and Mann-Whitney U (when non-parametric) comparing Pre- and Post-test in the CMJ

	Average	SD	SEM	P
CMJ total Impulse Pre-test	137.27	18.31	5.287	0.114
CMJ total Impulse Post-test	135.07	17.16	4.955	
CMJ total V _{take-off} Pre-test	2.05	0.14	0.042	0.127
CMJ total V _{take-off} Post-test	2.02	0.11	0.031	
CMJ total Jump Height Pre-test	0.21	0.03	0.008	0.112
CMJ total Jump Height Post-test	0.20	0.02	0.006	
CMJ total Acc Pre-test	-0.01	0.03	0.009	0.918
CMJ total Acc Post-test	0.01	0.02	0.008	
CMJ total Force _{peak} Pre-test	677.59	116.15	33.532	0.929
CMJ total Force _{peak} Post-test	675.08	99.08	28.604	

SD: standard deviation, SEM: standard error of the mean, P: level of significance obtained, CMJ: countermovement jump, V: velocity, Max: Maximal. Grey cells: non-parametric analyses. White cells: parametric analyses. Variables in light: not statistically significantly different. Variables in bold: statistically significantly different.

Paired t- and Mann-Whitney U tests found a significant difference between Pre- and Post-test only for the SJ total force_{peak}. The remaining variables were not statically different (Table 34).

Table 34: Paired t-tests (when parametric) and Mann-Whitney (when non-parametric) comparing Pre- and Post-test in the SJ

	Average	SD	SEM	P
SJ total Impulse Pre-test	136.30	22.22	6.163	0.224
SJ total Impulse Post-test	131.59	19.54	5.426	
SJ total V _{take-off} Pre-test	2.01	0.25	0.070	0.165
SJ total V _{take-off} Post-test	1.93	0.21	0.060	
SJ total Jump Height Pre-test	0.20	0.05	0.013	0.125
SJ total Jump Height Post-test	0.19	0.04	0.011	
SJ total Acc Pre-test	-0.01	0.03	0.008	0.105
SJ total Acc Post-test	0.01	0.03	0.010	
SJ total Force _{peak} Pre-test	781.70	175.63	48.712	0.033
SJ total Force _{peak} Post-test	711.78	102.68	28.481	

SD: standard deviation, SEM: standard error of the mean, *P*: level of significance obtained, CMJ: countermovement jump, V: velocity, Max: Maximal. Grey cells: non-parametric analyses. White cells: parametric analyses. Variables in light: not statistically significantly different. Variables in bold: statistically significantly different.

Total Force_{peak} decreased in the Post-test compared to the Pre-test during the SJ.

Paired t- and Mann-Whitney U tests were also performed to compare the difference between the delta ($\Delta = [DIF_{Post-Pre}]/Pre$) for each variable in between the groups (Table 35).

Table 35: Paired t-tests (when parametric) and Mann-Whitney (when non-parametric) of the Δ between the C and T conditions

	Average	SD	SEM	<i>P</i>
ΔROM_{Max} T	0.826	6.518	1.683	0.315
ΔROM_{Max} C	3.014	5.560	1.435	
$\Delta torque_{Max}$ T	0.284	19.448	5.021	0.399
$\Delta torque_{Max}$ C	3.300	16.276	4.202	
ΔFSS_{ROM} T	56.506	198.613	51.281	0.325
ΔFSS_{ROM} C	3.386	9.591	2.476	
ΔFSS_{torque} T	8.710	34.314	8.860	0.382
ΔFSS_{torque} C	-2.274	35.603	9.192	
$\Delta SMTU$ T	-0.041	0.194	0.050	0.321
$\Delta SMTU$ C	0.0583	0.611	0.157	
$\Delta Energy$ T	-0.012	0.180	0.046	0.030
$\Delta Energy$ C	0.043	0.471	0.121	
ΔCMJ Impulse T	61.355	14.754	4.448	0.339
ΔCMJ Impulse C	71.437	22.455	6.770	
ΔCMJ Force _{peak} T	338.034	72.294	20.869	0.357
ΔCMJ Force _{peak} C	362.977	60.194	17.376	
ΔSJ Impulse T	69.289	77.225	23.284	0.810
ΔSJ Impulse C	57.270	84.858	25.585	
ΔSJ Force _{peak} T	332.724	55.087	15.278	0.018
ΔSJ Force _{peak} C	379.096	63.634	17.649	

SD: standard deviation, SEM: standard error of the mean, *P*: level of significance obtained, Δ : delta, ROM: range of motion, Max: maximal, S: stiffness, MTU: muscle tendon-unit, T: trained, C: control, FSS: first sensation of stretch, CMJ: countermovement jump, SJ: squat jump. Grey cells: non-parametric analyses. White cells: parametric analyses. Variables in light: not statistically significant. Variables in bold: statistically significantly different.

Only the ΔSJ Force_{peak} and $\Delta Energy$ were statistically different between the control and the training conditions.

6.4.5 Presence of hormone levels as a covariate in the MTU structure, function and performance

Table 36 shows the hormonal concentration and the coefficient of variations obtained through saliva samples in both groups. The dependent variables that were correlated with either Oestrogen or Progesterone are presented in Table 37.

Table 36: Concentration of Oestrogen and Progesterone in both groups (average \pm standard deviation)

	CV	Concentration total
Saliva Oestrogen	2.17 \pm 1.63	4.07 \pm 1.38 pg/ml
Saliva Progesterone	2.59 \pm 1.24	312.77 \pm 231.63 pg/ml

CV: Coefficient of variation.

Table 37: Hormone concentration and dependent variables correlations

	Oestrogen	Progesterone
FSS _{torque}	-	$P = 0.045$ $r = -0.327^*$
S _{MTU}	$P = 0.004$ $r = 0.472^*$	-
Energy	$P = 0.014$ $r = 0.403^{**}$	-
CMJ Δ force _{peak}	-	$P = 0.030$ $r = 0.391^*$
SJ Δ force _{peak}	$P = 0.015$ $r = 0.426^*$	-
SJ Δ total force _{peak}	$P = 0.030$ $r = 0.536^*$	-
SJ Δ total impulse	-	$P = 0.001$ $r = -0.775^{**}$

FSS: First sensation of stretch. S: stiffness. MTU: Muscle tendon unit. CMJ: Countermovement jump. SJ: Squat jump. P = significance level. * = $P < 0.05$. ** = $P < 0.001$. r = correlation. -: not applicable analysis. Δ : (Post-Pre)/Pre. -: not applicable analysis.

6.5 Discussion

The primary aim of this chapter was to ascertain whether dancers may present asymmetries between the lower limbs with regards to vertical jumps and flexibility. The query had a great potential impact due to the importance of both capabilities for this population. When the flexibility performance between the limbs was compared, the results indicated that contemporary dance students presented significant between legs flexibility imbalances with regards to ROM_{Max}, torque_{Max}. The asymmetries in the ROM_{Max} agrees with previous literature (Sullivan et al., 1992, Kadel et al., 2005, Daneshjoo et al., 2013, Davenport et al., 2016) but contrasts with other authors (Agre and Baxter, 1987, Rahnama et al., 2005, Samadi et al., 2009, Oliveira et al., 2013). However, caution is needed for the comparison of the current study's results with those obtained from other authors, given the populations, laboratory protocols and equipment are diverse. Studies comparing asymmetries in flexibility were performed in football players (Daneshjoo et al., 2013, Agre and Baxter, 1987) (Rahnama et al., 2005, Oliveira et al., 2013), female collegiate athletes (Knapik et al., 1991)

and non-athletes (Samadi et al., 2009). Only a few studies were found assessing dancers (Davenport et al., 2016, Kadel et al., 2005).

Daneshjoo et al. (2013) found significant differences in the hamstrings of both limbs in football players. Participants showed greater ROM in the dominant leg (kicking leg) measured using a goniometer. However, other authors (Agre and Baxter, 1987, Knapik et al., 1991, Rahnama et al., 2005, Samadi et al., 2009, Oliveira et al., 2013), did not find between legs significant differences. All the aforementioned studies, however, have used goniometry to assess ROM_{Max}, (Knapik et al., 1991) and (Rahnama et al., 2005) assess the active flexibility. Notably, however, none of the studies reported the intensity for the stretch intervention. Previous authors (Davenport et al., 2016) found an asymmetry of 10° between in dancers with prior injuries. However, they assessed the abductors while this study assessed the hip extensors; no information about injury risks and asymmetries in the hamstrings in dancers, in the best of the authors' knowledge, was found. Finally, (Kadel et al., 2005) found asymmetries in the active flexibility (straight leg raise-test), but not in the passive hip flexion (similar test to the one performed in this study) in ballet dancers ranging from 8-13 years old. Nevertheless, active flexibility is also dependent on antagonist muscle strength while passive flexibility only relies on the flexibility of the stretched muscle. Additionally, the physiology of teenagers cannot be reliably compared to that of mature adults, given that tendon compliance alters due to aging (Adams et al., 1999, Wilke et al., 2018, Bassey, 1998).

It is expected that an increase in the torque_{Max} would happen along with the increase in the ROM_{Max} (Blazevich et al., 2012), therefore, asymmetries in ROM would lead also to asymmetries in torque. These assumptions were confirmed by the statistical difference in the torque_{Max} between the limbs found in the present research. Although asymmetries in both, ROM and torque were found, it is still possible that the S_{MTU} do not differ between the limbs, since stiffness is calculated by the variation in the ROM divided by the variation in the torque. Indeed, S_{MTU} was not found to be statistically different between the limbs, corroborating previous researchers (Blazevich et al., 2012) who found different stiffness in different flexibility levels. The authors, however, compared different populations to that in

the present study, assessing more and less flexible participants, but not trained in flexibility populations.

This is the first study, in the best of the current author's knowledge, comparing S_{MTU} between the limbs of the same individual in populations trained in flexibility. Considering also the fact that S_{MTU} represents the resistance offered by the MTU against stretching, both limbs presenting similar S_{MTU} would not justify the choice of one or another limb as preferred gesture leg due to the ease of performing the movements. It is thus, tempting to imply that the decision for the preferred gesture limb is due to self-perceived (Mertz et al., 2012) aesthetic reasons rather than easiness of performing the movement (Lin et al., 2013).

All the aforementioned studies reporting asymmetries evaluated only the ROM representing flexibility, however, (Weppeler and Magnusson, 2010) suggested the assessment of other variables to understand the MTU response to the stretch, using both, a biomechanical and a sensory approach. Both ROM_{Max} and FSS_{ROM} were used in this study to provide information on the biomechanical behaviour of the MTU while the $torque_{Max}$ and the FSS_{torque} were used to understand the sensory response to stretch. While $torque_{Max}$ is the maximum tension tolerated and therefore, the end of the stretch, the FSS_{torque} represents the beginning of the stretch, signaled when tension is exerted on the muscles and the mechanoreceptors are stimulated (Magnusson et al., 1996a). Increases in either or both these variables may indicate modification or difference in the stretch tolerance. No studies were found, in the best of the author's knowledge, comparing the FSS_{torque} between the limbs. Previous work (Pessali-Marques, 2015) compared the FSS_{torque} after stretch intervention in dancers and non-dancers. Only one limb was randomly assessed for the tests while the contralateral remained as the control group; therefore, no information about asymmetries was given. Considering the fact that the tension applied in the mechanoreceptors may act as a trigger to the FSS signal (Avela and Komi, 1998a), it was expected that the same tension (FSS_{torque}) would be perceived in both limbs, even though the ROM was different between the limbs. The results found in this research confirmed this hypothesis, as no significant difference in the FSS_{torque} was found in between the legs.

The FSS_{ROM} together with the ROM_{Max} provides information concerning the biomechanical modifications of the tissue. Although the ROM_{Max} was different, no significant difference was found in the FSS_{ROM} between the limbs. Altogether, the findings of this study suggest a similarity in the tolerance perception at the beginning of the stretch, however, they also indicate a difference in the tolerance perception at the end of the stretch. This difference in the tolerance at the end of the stretch does not appear to be related to differences in the biomechanical characteristics of the MTU since no difference in the S_{MTU} was found between the limbs. Substantiating the implication previously raised, motivational factors might play a role for the greater tolerance in the leg chosen to be the gesture leg, probably due to the side they have to perform in the choreographies, which, therefore, require greater ROM for the aesthetics.

A second hypothesis was that limbs with different ROM_{Max} could present different stiffness for a comparable ROM (Blazevich et al., 2012) and thus, different force production between the limbs, potentially due to a difference in muscle shortening velocity (Ochala et al., 2007b), which could even culminate in injuries. Supporting this latter part of the hypothesis, (Agre and Baxter, 1987) found that subjects with a hip flexion ROM difference of 6 degrees were more prone to knee and lower back injury. (Knapik et al., 1991) found that a flexibility asymmetry greater than 15% in the lower limbs was related to 2.6 times greater predisposition to a lower extremity injury. Muscular tightness, which restricts the ROM, is also believed to predispose the muscle to injury and to impair performance in sports where flexibility is important (Rahnama et al., 2005). Although differences in the ROM and torque were found between the limbs, no differences in S_{MTU} were found, suggesting that asymmetries in the ROM and torque are not strictly linked to differences in S_{MTU} and hence, differences in force production.

To verify the influence of the S_{MTU} in force production independently of asymmetries in flexibility, the CMJ and SJ were performed. No peak force and impulse imbalances were found when the legs were compared for either of the two jump techniques. Despite the assessment of strength asymmetry being commonly performed using isokinetic dynamometry (Daneshjoo et al., 2013) (Davenport et al., 2016) (Agre and Baxter, 1987, Rahnama et al., 2005, Samadi et al., 2009, Oliveira et al., 2013, Knapik et al., 1991).

(Impellizzeri et al., 2007) assessed the validity of a vertical jump test for measuring the force produced by each leg using independent force plates. The authors compared the data from the peak vertical CMJ force, the isokinetic leg extension and the isometric leg press, it was found that the jump test was a valid and reliable method to measure lower limb strength, increasing the validity of the chosen method, hence, findings of the current study.

The current study's results indicate that the $Peak_{force}$ during the SJ was significantly smaller in the Post-test only in the control leg. (Knapik et al., 1991) found that a strong force on one side may result in injury to the contralateral leg, as the weaker leg would need to absorb more force in the Z-axis, produced by the stronger leg, during the landing. The D leg (more flexible) was found to be the weaker leg, forced to absorb the increased force generated by the nD (less flexible) leg. As both legs are controlled by the same neural system, it is possible that neural control of the forces produced by the stronger leg suffers a decrease to compensate the weaker leg and minimise the risk of injuries.

The second aim of this study was to determine if any level of asymmetries in the MTU, especially S_{MTU} , between the lower limbs, could be accentuated by an acute stretch protocol and, consequently, affect performance in jumps and flexibility in dancers. Therefore, a stretch intervention was performed on the D leg aiming to increase any possible asymmetry already existent. The ROM_{Max} did not increase in the intervention leg but showed a statistical increase in the control limb. The lack of increase found in the intervention group contradicts previous literature using the CT stretching (Yeh et al., 2007, Yeh et al., 2005, Herda et al., 2011a, Cabido et al., 2014). (Cabido et al., 2014) found significant increases in hamstring flexibility after CT stretching and in the First Sensation of Tightness (FST_{ROM}) contradicting the findings of the current chapter. However, (Cabido et al., 2014) stretched the hamstrings through the knee extension, whereas this study flexed the hips maintaining the knees extended as performed in previous research (Halbertsma and Göeken, 1994, Halbertsma et al., 1996, Goeken and Hof, 1994, Ylinen et al., 2009) and systematically discussed in Chapter 1⁴².

⁴² Vide pages 95-97

The significant increase in the ROM_{Max} observed in the control leg, which was not subject to stretch, could be due to central neurological signals affecting both lower limbs even when only one limb is being stretched. The increase in temperature and any possible influence on the MTU was anticipated and controlled as discussed in the previous chapter. Although the non-modification in $torque_{Max}$ suggested a modification in the biomechanical characteristics of the MTU rather than in the stretch tolerance, the increase in the tolerance in the control leg may suggest sensory mechanisms played a role. These mechanisms, however, are still not clear.

Another possibility could be that neither the 6 series of the test nor the 4 series of stretching was enough to allow complete accommodation of the tissue. Pessali-Marques et al. (2016) compared the accommodation in dancers and non-dancers and found that the dancers were still accommodating in the 6th series while the tissue accommodation in non-dancers stopped in the 4th series showing that dancers, who are trained in flexibility, need more series, therefore, more training to cause the same adaptations as the non-dancers, who are not trained in flexibility. This assumption agrees with the principle of trainability, which states that the more fully a person is trained with respect to a given fitness component, the less there are remnants of that component to be trained in the future (Kent, 2006). If the difference in the limbs is understood as a difference in the training levels between the limbs, the trainability principle would also justify the increase in the control limb and the non-increase in the training limb. This is similar to the physiological reserve principle. Indeed, the physiological reserve represents the gap of improvement still reachable before the physiological limit. The closer to the maximum, the smaller the physiological reserve and the possibility of improvement.

The intervention on the D leg showed no significant decrease in the CMJ total variables but found a smaller total $force_{Max}$ and total $force_{peak}$ for the SJ. The lack of change in the vertical jumps height, post stretch intervention, do not agree with previous research showing a decrease in the jump height following flexibility training protocols (Herda et al., 2008, Morrin and Redding, 2013). The decrease in the jump height was justified due to a decrease in S_{MTU} (Costa et al., 2010, Herda et al., 2010b) and, therefore, a decrease in the energy absorbed. In addition, the constant torque (CT) stretching was found in the literature to be the

technique with greater results in terms of reducing stiffness (Cabido et al., 2014, Herda et al., 2011a, Yeh et al., 2005). However, no decrease in the S_{MTU} after the intervention was found in this study, justifying the lack of decrease in the jump height. As only one (and the more trained limb) underwent the intervention in the current research, the intensity of the training might not have been enough to affect S_{MTU} and thus, jump performance. This result reinforces (Seyfarth et al., 2000) suggestion that an optimal S_{MTU} would be required for each type of movement.

Interestingly, the $Force_{peak}$ during the SJ decreased in the control compared to the trained limb. Considering that the ROM_{Max} increased only in the control, the decrease in the peak force, expected to occur in the trained limb was observed in the control limb. Therefore, even with this decrease in force production, jump height was not different after the intervention. It seems to be pertinent that the trained limb might have reached a buffer zone where small changes in any variable would have very little effect on jump performance.

Finally, due to the possible influence of the menstrual cycle hormones in the studied variables, the hormonal concentration of oestrogen and progesterone and correlations with each one of them and the dependent variables were performed. The hormonal concentration of Oestrogen and Progesterone were in agreement with previous literature that found average concentrations of 3 mg of synthetic progesterone and from 0.02 to 0.035 mg of synthetic oestrogen in contraceptives (Banai, 2017). A significant negative correlation was found between Progesterone and FSS_{torque} and SJ Δ total impulse and a significant positive correlation was found with CMJ Δ $force_{peak}$. Oestrogen was found to be positively correlated with S_{MTU} , Energy, SJ Δ $force_{peak}$ and SJ Δ total $force_{peak}$. These findings corroborate results in the previous study, suggesting that oestrogen has a loosening effect on the MTU while progesterone acts as a stiffening agent in the MTU. Consequently, the variables that require high levels of stiffness for performance (such as the vertical jumps) tend to be positively related with progesterone, while the increase in the muscle complacency tends to be related to the increase of oestrogen. These results are important to be considered by athletes from different sport modalities to select the type of contraception (combined or progesterone only).

6.6 Conclusion

Dancers were shown to have asymmetries in the ROM_{Max} and $torque_{Max}$ between the limbs, but no differences in the S_{MTU} , energy, FSS_{ROM} and FSS_{torque} were found. Additionally, no differences in the CMJ and SJ performance was found between the legs, probably due to the non-difference in the S_{MTU} . Four series of constant torque stretching may not have proven sufficient to increase asymmetries in the dominant limb, which already presented greater values of ROM_{Max} and $torque_{Max}$. However, modifications were seen in the control leg that did not undertake the intervention, probably due to the trainability principle. The reasons for the increase in the control contralateral limb still need to be clarified in further studies. This chapter also concluded that the dominant and non-dominant limbs have different pain thresholds at the end of the stretch but not at the beginning, suggesting that pain coping strategies and performance motivation might play a role for the different flexibility between the limbs. Finally, oestrogen and progesterone concentrations, even in participants under contraception play a role in the MTU. Progesterone has a tightened effect while oestrogen has a loosening effect.

Chapter 4: Flexibility asymmetry and impact of an acute stretch intervention on the jump kinematics in dancers under contraception

“O bom mestre é aquele superado pelo seu discípulo”

Leonardo da Vinci

“The good master is the one surpassed by his pupil.”

Leonardo da Vinci

7.1 Introduction

In the previous chapter as with previous studies jump performance is greater in dancers compared with non-dancers' populations. It is likely that this is due to the fact that jumps are part of a dance routine and required to improve not only the maximal height but also the technique of jumping, which is crucial for dancers, especially those aimed at becoming professional. During the classes, dance teachers often require a "big *plié*"⁴³ before jump movements, justifying that "the bigger the *plié*, the higher the jump". However, this hypothesis is not based on scientific literature.

During the initial phase of any vertical jump, an eccentric downwards movement is performed, including flexion of the hip, knee and ankle (Menzel et al., 2013b). This necessitates eccentric muscle action of the quadriceps, the hamstrings, the gluteus and the triceps surae. A number of authors suggested that a high degree of flexion and proper alignment of the participating joints correlates with the number of ground forces absorbed during the landing, protecting the knee especially against anterior cruciate ligament injuries (Souza and Powers, 2009, Shultz and Schmitz, 2009, Turner et al., 2018). This protection was proposed to be related to S_{MTU} (a ratio between the MTU length and the passive tension that occurred in the movement). Indeed, since the torque increases alongside the ROM, it would be expected that the bigger the ROM, the bigger the S_{MTU} at the ROM_{Max} . Nevertheless, this is only an assumption to be tested, given that S_{MTU} is a ratio between the ROM and torque. Our results in Chapter 3 showed no differences in the S_{MTU} between the lower limbs, although dancers presented asymmetries in ROM. Additionally, results in Chapter 2 showed no differences in the S_{MTU} between dancers and non-dancers, although differences in the ROM were also found between the populations. However, it was also found that dancers did not perform better than non-dancers when performing vertical jumps. Therefore, the assessment of asymmetries in the kinematic variables of the vertical jumps might provide additional information about asymmetries in the lower limb in dancers.

It is important to consider that most studies concerning vertical jumps were performed in populations that are not trained in flexibility (Unick et al., 2005, Menzel et al., 2013a,

⁴³ A movement in which a dancer bends the knees and straightens them again. It is used in jumps and turns to provide impulse, absorb shock, and as an exercise to loosen muscles and to develop balance. See Appendix C page 269.

Linthorne, 2001, McElveen et al., 2010, Vanezis and Lees, 2005), therefore, what is considered a “high degree of flexion” was not reported, and it could be anything related to the ability to perform a squat up to 90 degrees of knee and hip flexion. It is questionable if very flexible populations, such as dancers, would be able to use the S_{MTU} as effectively as non-dancers during vertical jumps. Accordingly, Blazeovich et al. (2012) suggested that for the same angle (close to 90 degrees in the squat, as previously mentioned), more flexible people could present less stiffness than less flexible participants. No previous studies, in the best of the authors’ knowledge, were found analysing the jump performance and stiffness relationship in very flexible participants. In Chapter 2, however, our results showed that the asymmetries in ROM and Torque either between the limbs or between different populations were not related to differences in S_{MTU} . In addition, the stretch intervention applied in Chapter 3 was also not enough to modify S_{MTU} and, consequently, the kinetic of the flexibility and jump movements. It is necessary to know, however, if similar results would be found for the kinematic variables, which could affect the aesthetic of the dance movements.

Differences may also be found if performance in vertical jumps is analysed in the right and left lower limbs separately. Although similar levels of performance with contralateral limbs are expected, as dance is considered a bilateral activity (Prati and Prati, 2006), it is realistic that dancers will develop an accentuated asymmetric structure as they learn, practice and perform skills and techniques mostly for a single side of their body (Kimmerle and Science, 2010). According to (Aquino, 2010), the characteristic repetitiveness of dance may be associated with imbalances between muscle groups. Several studies found asymmetries in the muscular strength in dancers (Aquino, 2010, Gupta et al., 2004). However, no differences were found in the $force_{Max}$ and other strength-related variables in the previous chapters of this research. It is important to know whether these asymmetries in flexibility would affect the kinematics and, therefore, performance in jumps.

This chapter aims firstly, to assess if any level of asymmetry in flexibility between the lower limbs may affect kinematics and therefore, performance in the vertical jumps; secondly, to evaluate any influence of a unilateral stretch session in the same variables. The alternative hypothesis is that due to asymmetries in flexibility between the legs, the kinematics of the joints will be affected ultimately affecting jump performance, even though the S_{MTU} does not

modify. The second alternative hypothesis is that the unilateral stretching of the most flexible limb will increase any imbalance already existent in the kinematics.

7.2 Methods

7.2.1 Participants

Fifteen female undergraduate contemporary dance students comprised this study (mean [SD]: age; 21 [7] years, body mass; 63.22 [5.74] kg, height; 1.61 [0.03] m, body fat; 27.01 [2.77] %). All participants were taking either progesterone-only or combined (oestradiol and progesterone) birth contraception. Inclusion and exclusion criteria are described in the Overall Methods⁴⁴.

7.2.2 Procedures

The procedures were similar to those performed in Chapter 3⁴⁵, the only difference being the addition of the reflective markers⁴⁶ for 3D video-analysis and the electrodes for the electromyography⁴⁷.

7.2.3 Outcome variables

Variables summarised in Table 38 were collected in the Pre- and Post-test, with exception to hormone samples, which were collected once.

Table 38: Outcome variables Chapter 4

Flexibility	Vertical jump	Jump kinematics	EMG	Hormone
ROM _{Max} Torque _{Max}	Jump height Force _{peak}	Knee, Ankle, Hip angles and angular velocity	EMG _{ST} EMG _{RF} during CMJ and SJ	Oestrogen and Progesterone (saliva)

ROM: Range of motion, Max: Maximal, EMG: electromyography, RF: rectus femoris, ST: semitendinosus, CMJ: countermovement jump, SJ: squat jump.

Each one of the joint angles was measured at four phases during the CMJ and SJ: Preparatory Squat, Take-off, Landing and Landing Squat (Figure 44).

⁴⁴ Vide Overall Methods section 3.1 and 3.2 page 53

⁴⁵ Vide Chapter 3 section 6.2.2 page 129

⁴⁶ Vide Overall Methods section 3.3.6 page 69

⁴⁷ Vide Overall Methods section 3.3.8 page 73

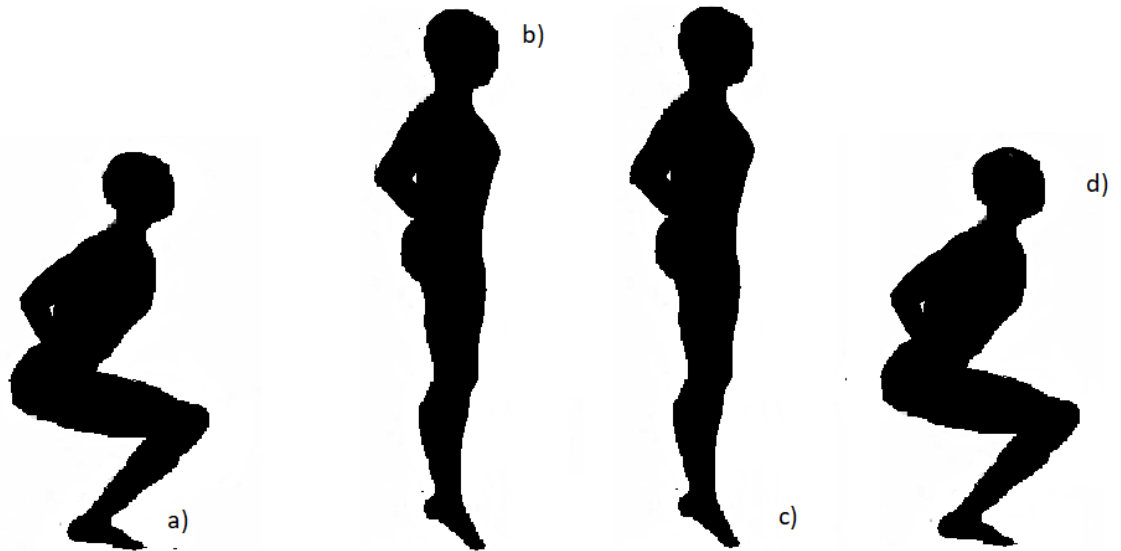

Figure 44: Jump phases during which angles were analysed – a) Preparatory squat: the lowest point achieved in the eccentric phase downwards, b) Take-off phase: the point at which no forces were reported by the force plate, c) Landing: the phase at which the force plate records the force following from the aerial phase of the jump, d) Landing squat: the lowest point achieved in the eccentric phase downwards breaking from the jump. (Figure – Produced by Bárbara Pessali-Marques).

The joint angular velocity was measured at two phases during the vertical jumps (Figure 45).

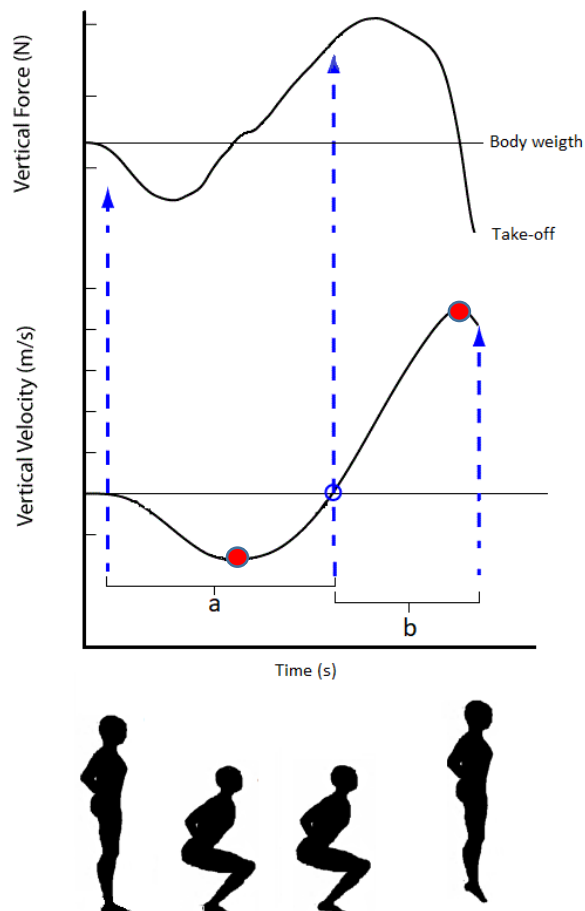

Figure 45: Phases where the angular velocity (red dots) was calculated for all the evaluated joints: a) eccentric phase of the jump, b) concentric phase of the jump (Illustrative figure produced by Bárbara Pessali-Marques).

7.3 Statistical Analyses

SPSS Statistics (v24 International Business Machines Corporation. New York. USA) was used for statistical analyses. Levene and Shapiro-Wilk statistic tests were performed to test the homogeneity of variance and the normality of the data, respectively. The comparison between control (C) and trained (T) lower limbs (condition), and Pre- and Post-test (time) for all the dependent variables was performed using the ANOVA repeated measures (when parametric) and the Friedman test (when non-parametric). Post hoc pairwise and Wilcoxon comparisons were performed, when necessary, to highlight any interaction. Paired t-tests were performed to compare the Pre- and Post-test between the combined legs (sum of D and nD limbs) where the action was deemed to involve both legs simultaneously. A second analysis using the Paired t-tests was also performed to compare the relative change (i.e. delta) between the Pre- and Post-tests ($[\text{Post-Pre}]/\text{pre}$) for each variable between the groups (when parametric) and Mann-Whitney (when non-parametric). Finally, co-variance analyses (ANCOVA) were performed when necessary to factor out any hormonal influence on the dependent variables where appropriate. The statistical significance adopted was $\alpha \leq 0.05$, study power at $\beta \geq 0.8$ (and effect size $p\epsilon^2 \geq 0.2$ where study power was adequate). Descriptive statistics are presented as average \pm standard deviation (SD).

7.4 Results

7.4.1 Parametricity checks

The characterisation of the DCT and contraception status are shown in the Results section Chapter 3⁴⁸. All variables presented significance level > 0.05 for the homogeneity test and normality except for the variables presented in Table 39 and Table 40.

Table 39: Non-parametric variables (Shapiro-Wilk)

Variable	Jump	Phase	Time	Condition	<i>P</i>
Hip Angle	CMJ	Preparatory squat	Pre	Control	0.048
Ankle Angle	CMJ	Take off	Post	Control	0.009
Hip Angle	CMJ	Landing	Post	Control	0.043
Ankle Angle	SJ	Landing Squat	Post	Control	0.002
Knee Angle	SJ	Landing Squat	Post	Control	0.008
Ankle angular velocity	CMJ	Eccentric phase	Pre	Control	0.004
Ankle angular velocity	CMJ	Eccentric phase	Post	Control	0.001
Hip angular velocity	CMJ	Eccentric phase	Post	Control	0.004
Ankle angular velocity	CMJ	Eccentric phase	Pre	Training	0.001
Ankle angular velocity	CMJ	Eccentric phase	Post	Training	0.001

⁴⁸ Vide Tables 31 and 32 Chapter 3 page 13.

Hip angular velocity	CMJ	Eccentric phase	Post	Training	0.002
Ankle angular velocity	SJ	Eccentric phase	Post	Control	0.001
Hip angular velocity	SJ	Eccentric phase	Post	Training	0.035
Knee angular velocity	SJ	Concentric phase	Pre	Control	0.015
EMG _{RF}	SJ	Rectus Femoris	Pre	Training	0.015

CMJ: Countermovement jump, SJ: Squat jump, Pre: Pre-test, Post: Post-Test, EMG: Electromyography, RF: Rectus femoris, P: significance level.

Table 40: Non-parametric variables' delta of Pre- and Post-tests per group (Shapiro-Wilk).

Phase	Jump	Condition	Delta	P
Preparatory Squat	CMJ	Control	Δ Hip	0.024
	SJ	Control	Δ Knee	0.022
Take-off	CMJ	Training	Δ Ankle	0.015
		Control	Δ Knee	0.025
	SJ	Control	Δ Ankle	0.013
		Control	Δ Knee	0.017
Landing	CMJ	Control	Δ Ankle	0.004
		Control	Δ Knee	0.001
	SJ	Training	Δ Ankle	0.013
		Control	Δ Ankle	0.001
Landing Squat	CMJ	Training	Δ Knee	0.002
	SJ	Control	Δ Ankle	0.001
		Control	Δ Knee	0.006
SJ	EMG	Training	Δ EMG _{RF}	0.004
Angular velocity CMJ	Eccentric	Training	Δ Ankle	0.001
		Training	Δ Hip	0.006
	Concentric	Training	Δ Ankle	0.005
Angular velocity SJ	Eccentric	Training	Δ Knee	0.024
		Training	Δ Hip	0.042
		Control	Δ Hip	0.002
	Concentric	Control	Δ Knee	0.023
		Training	Δ Knee	0.001
		Control	Δ Hip	0.001

Δ: (Post-Pre)/Pre, CMJ: Countermovement jump, SJ: Squat jump, P: significance level.

7.4.2 Vertical jumps joint angles: Condition (Training and Control) and Timepoint (Pre- and Post-test) comparisons

Tables 41 and 42 show the descriptive analysis of the CMJ and SJ respectively, followed by Table 43 presenting the ANOVA repeated measures (when parametric) and Friedman (when non-parametric) comparing condition vs time of vertical jump joint angles at Preparatory Squat, Take-off, Landing and Landing Squat phases on CMJ and SJ.

Table 41: Descriptive statistics of CMJ angles in degrees (average ± standard deviation)

Jump	Phase	Joint	Condition	Time	Average	SD
CMJ	Preparatory Squat	Ankle Angle	Training	Pre-Test	36.8	4.9
				Post-test	34.6	5.2
		Ankle Angle	Control	Pre-Test	32.2	6.4
				Post-test	33.2	3.8
	Hip Angle	Training	Pre-Test	87.2	13.2	

			Control	Post-test	81.2	21.6		
				Pre-Test	83.5	15.6		
			Post-test	84.2	6.6			
		Knee Angle	Training	Pre-Test	17.0	16.0		
				Post-test	16.8	11.0		
			Control	Pre-Test	71.3	13.0		
	Take-off	Ankle Angle	Training	Pre-Test	84.3	11.5		
				Post-test	-39.8	22.4		
			Control	Pre-Test	-38.1	19.7		
				Post-test	-21.9	10.4		
			Hip Angle	Training	Pre-Test	17.7	17.2	
					Post-test	18.0	12.2	
		Control		Pre-Test	17.0	16.0		
		Knee Angle	Training	Post-test	16.8	11.0		
				Pre-Test	1.7	22.1		
			Control	Post-test	-0.1	8.0		
				Pre-Test	0.6	19.8		
			Landing	Ankle Angle	Training	Post-test	-1.2	9.4
						Pre-Test	-24.7	10.0
		Control			Post-test	-23.4	7.6	
					Pre-Test	-21.5	9.9	
		Hip Angle		Training	Post-test	-21.9	10.4	
					Pre-Test	30.7	10.5	
				Control	Post-test	30.8	11.5	
	Pre-Test				29.5	9.4		
	Knee Angle	Training		Post-test	30.5	12.6		
				Pre-Test	16.6	8.2		
		Control		Post-test	14.1	9.3		
Pre-Test				14.9	10.1			
Landing Squat	Ankle Angle	Training	Post-test	14.4	10.0			
			Pre-Test	33.9	9.6			
		Control	Post-test	33.0	10.6			
			Pre-Test	31.9	9.5			
	Hip Angle	Training	Post-test	31.2	9.3			
			Pre-Test	77.7	19.0			
		Control	Post-test	77.0	26.1			
			Pre-Test	76.2	19.0			
	Knee Angle	Training	Post-test	76.9	23.8			
			Pre-Test	81.6	24.5			
Control	Training	Post-test	75.5	25.6				
		Pre-Test	76.9	25.3				
Post-test	75.7	19.7						

CMJ: Countermovement jump, SD: Standard deviation. For detailed explanation of angle directions vide Overall Methods Figure 18 page 72.

Table 42: Descriptive statistics of SJ angles in degrees (average \pm standard deviation)

Jump	Phase	Joint	Condition	Time	Average	SD
SJ	Preparatory Squat	Ankle Angle	Training	Pre-Test	32.7	4.7
				Post-test	29.4	8.2
			Control	Pre-Test	33.8	5.1
				Post-test	35.8	5.0
		Hip Angle	Training	Pre-Test	83.0	12.7
				Post-test	89.5	15.3
			Control	Pre-Test	83.6	7.9
				Post-test	83.0	10.3

		Knee Angle	Training	Pre-Test	78.9	13.1
				Post-test	70.6	15.2
		Control	Pre-Test	90.0	13.0	
			Post-test	94.6	7.6	
	Take-off	Ankle Angle	Training	Pre-Test	-43.3	8.8
				Post-test	-36.4	22.4
			Control	Pre-Test	-40.4	6.5
				Post-test	-34.7	22.4
		Hip Angle	Training	Pre-Test	15.6	8.1
				Post-test	20.1	20.5
			Control	Pre-Test	14.2	9.2
				Post-test	21.1	20.5
		Knee Angle	Training	Pre-Test	-3.1	6.3
				Post-test	3.7	26.7
			Control	Pre-Test	-5.2	7.3
				Post-test	3.5	26.1
	Landing	Ankle Angle	Training	Pre-Test	-21.8	10.9
				Post-test	-24.6	8.4
			Control	Pre-Test	-20.6	10.2
				Post-test	-21.5	7.8
		Hip Angle	Training	Pre-Test	30.8	9.2
				Post-test	30.6	10.7
			Control	Pre-Test	30.9	10.3
				Post-test	29.3	12.2
Knee Angle		Training	Pre-Test	17.7	10.5	
			Post-test	15.5	11.0	
		Control	Pre-Test	16.4	10.8	
			Post-test	13.9	9.5	
Landing Squat	Ankle Angle	Training	Pre-Test	36.5	5.7	
			Post-test	31.3	14.5	
		Control	Pre-Test	34.3	6.8	
			Post-test	28.6	14.5	
	Hip Angle	Training	Pre-Test	82.4	16.8	
			Post-test	80.7	22.7	
		Control	Pre-Test	81.9	15.5	
			Post-test	79.7	24.2	
	Knee Angle	Training	Pre-Test	86.5	16.0	
			Post-test	74.5	25.9	
		Control	Pre-Test	83.6	16.8	
			Post-test	72.9	24.0	

SJ: Countermovement jump, SD: Standard deviation. For detailed explanation of angle directions vide Overall Methods Figure 18 page 72.

Table 43: Vertical jumps ANOVA repeated measures with pairwise comparisons (when parametric) and Friedman with Wilcoxon comparisons (when non-parametric) of joint angles.

			Pre-Test Training vs Pre-Test Control	Post-Test Training vs Post-Test Control	Pre-Test Training vs Post-Test Training	Pre-Test Control vs Post-Test Control	Main effect
CMJ	Preparatory Squat	Ankle Angle	0.131	0.119	0.487	0.903	$F_{1.543} P=0.234; \eta^2_p=0.123; \beta=0.304$
		Hip Angle	-	-	-	-	0.552
		Knee Angle	0.003	0.118	0.044	0.001	$F_{7.642} P=0.001; \eta^2_p=0.410; \beta=0.977$
	Take-off	Ankle Angle	-	-	-	-	0.941
		Hip Angle	0.633	0.204	0.958	0.755	$F_{0.111} P=0.775; \eta^2_p=0.008; \beta=0.062$
		Knee Angle	0.469	0.377	0.784	0.716	$F_{0.147} P=0.731; \eta^2_p=0.010; \beta=0.065$
	Landing	Ankle Angle	0.234	0.632	0.434	0.632	$F_{0.738} P=0.536; \eta^2_p=0.058; \beta=0.192$
		Hip Angle	-	-	-	-	0.972
		Knee Angle	0.722	0.746	0.756	0.846	$F_{0.119} P=0.807; \eta^2_p=0.010; \beta=0.063$
	Landing Squat	Ankle Angle	0.793	0.873	0.763	0.830	$F_{0.073} P=0.974; \eta^2_p=0.006; \beta=0.062$
		Hip Angle	0.744	0.739	0.825	0.965	$F_{0.090} P=0.965; \eta^2_p=0.007; \beta=0.065$
		Knee Angle	0.964	0.872	0.805	0.966	$F_{0.019} P=0.996; \eta^2_p=0.002; \beta=0.053$
SJ	Preparatory Squat	Ankle Angle	0.737	0.050	0.376	0.192	$F_{2.005} P=0.128; \eta^2_p=0.125; \beta=0.479$
		Hip Angle	0.857	0.928	0.076	0.928	$F_{1.957} P=0.135; \eta^2_p=0.123; \beta=0.469$
		Knee Angle	0.005	0.001	0.457	0.076	$F_{12.129} P=0.001; \eta^2_p=0.464; \beta=0.999$
	Take-off	Ankle Angle	0.284	0.931	0.168	0.306	$F_{1.419} P=0.259; \eta^2_p=0.092; \beta=0.237$
		Hip Angle	0.469	0.971	0.328	0.329	$F_{1.000} P=0.340; \eta^2_p=0.067; \beta=0.158$
		Knee Angle	0.521	0.430	0.189	0.248	$F_{1.624} P=0.224; \eta^2_p=0.104; \beta=0.228$
	Landing	Ankle Angle	0.669	0.290	0.282	0.833	$F_{0.632} P=0.495; \eta^2_p=0.046; \beta=0.129$
		Hip Angle	0.841	0.340	0.846	0.340	$F_{0.076} P=0.854; \eta^2_p=0.006; \beta=0.059$
		Knee Angle	0.458	0.708	0.343	0.980	$F_{0.372} P=0.592; \eta^2_p=0.028; \beta=0.091$
	Landing Squat	Ankle Angle	-	-	-	-	0.250
		Hip Angle	0.838	0.672	0.362	0.698	$F_{0.108} P=0.844; \eta^2_p=0.008; \beta=0.063$
		Knee Angle	-	-	-	-	0.987

CMJ: Countermovement jump, SJ: Squat jump, Grey cells: non-parametric analyses. White cells: parametric analyses. Variables in light: not statistically significant. Variables in bold: statistically significantly different. - : No main effect, therefore no further comparisons required

Figures below (Figures 46 -51) illustrate the outcome measures for each joint and time phase for both conditions. It is notable that the knee joint in both CMJ and SJ Preparatory Squat was different between limbs prior to the stretch intervention. No other joint angles differed between limbs pre-interventions. The degree of flexion of the Knee Angle during the CMJ Preparatory Squat phase decreased significantly in the Post-test for the Training condition (average \pm SD [$^{\circ}$] - T Pre-Test: 89.3 ± 15.7 , Post-Test 75.2 ± 13.5), but increased for the Control condition (average \pm SD [$^{\circ}$] - C Pre-test: 67.8 ± 12.8 , Post-test 84.7 ± 11.8).

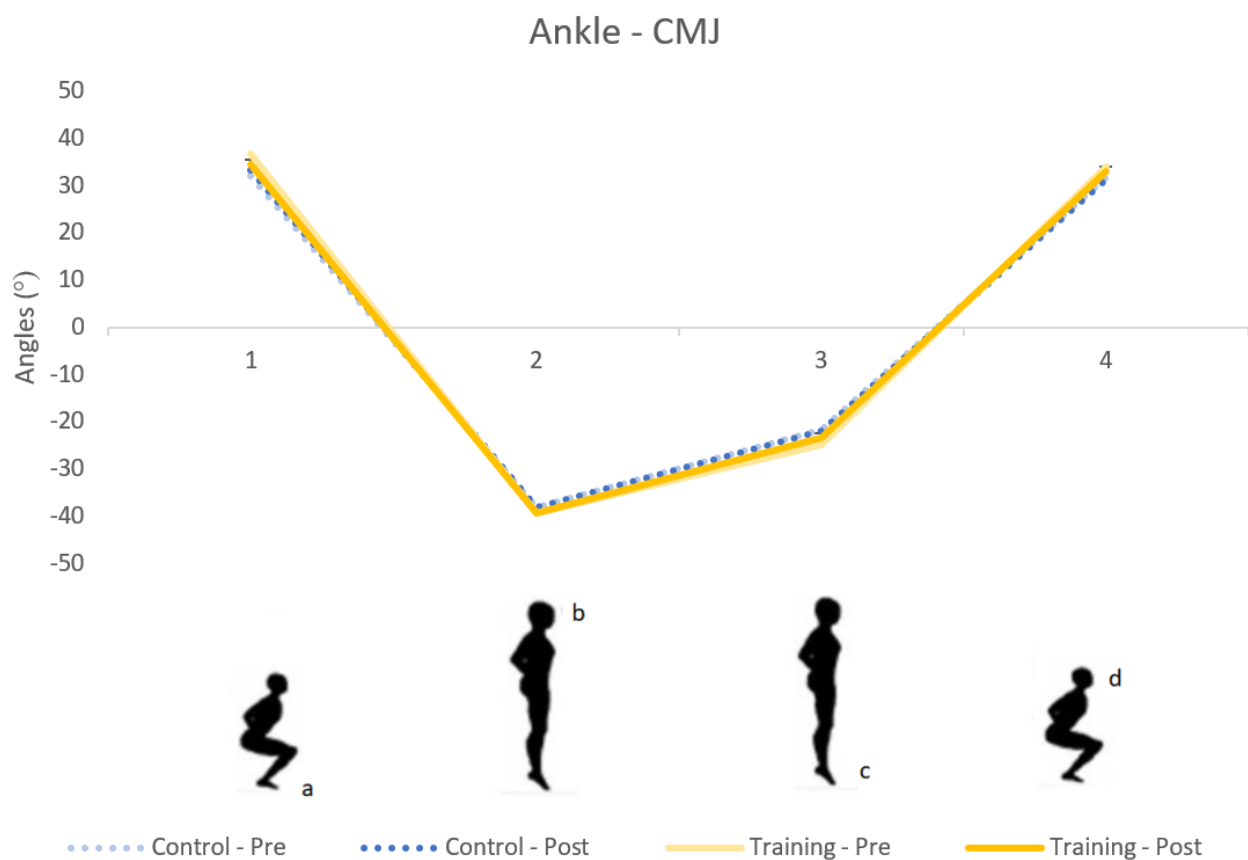

Figure 46: ankle angle variation during CMJ phases.

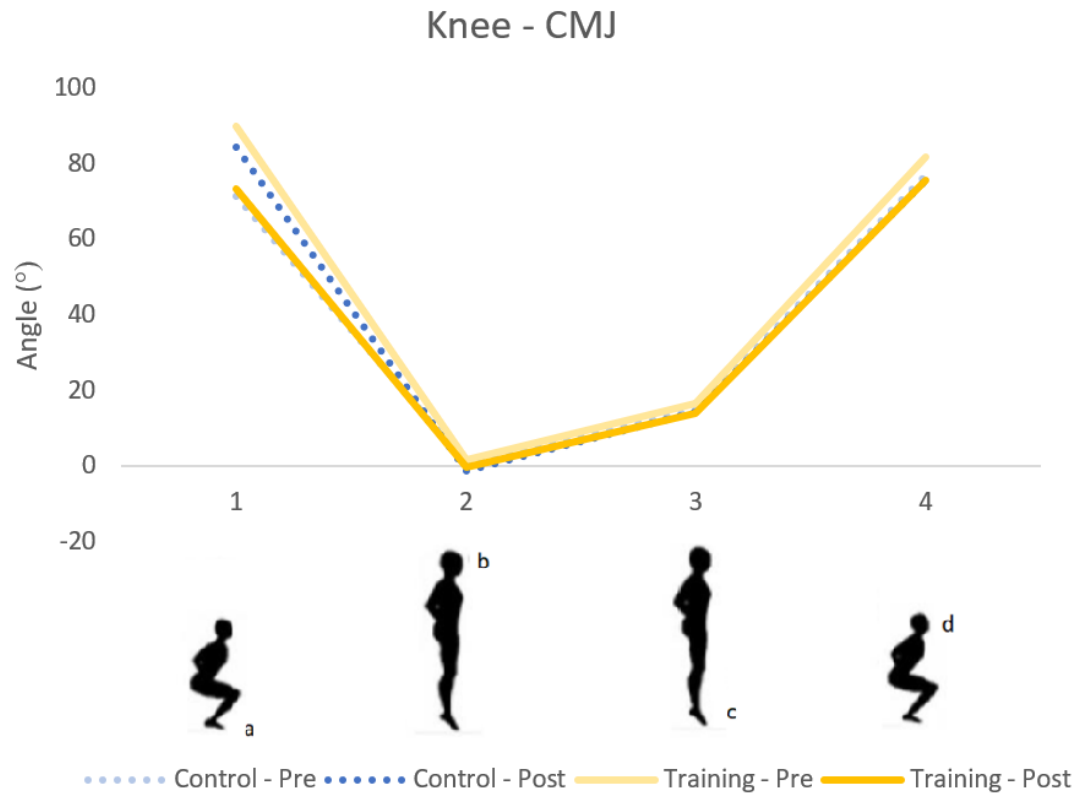

Figure 47: knee angle variation during CMJ phases

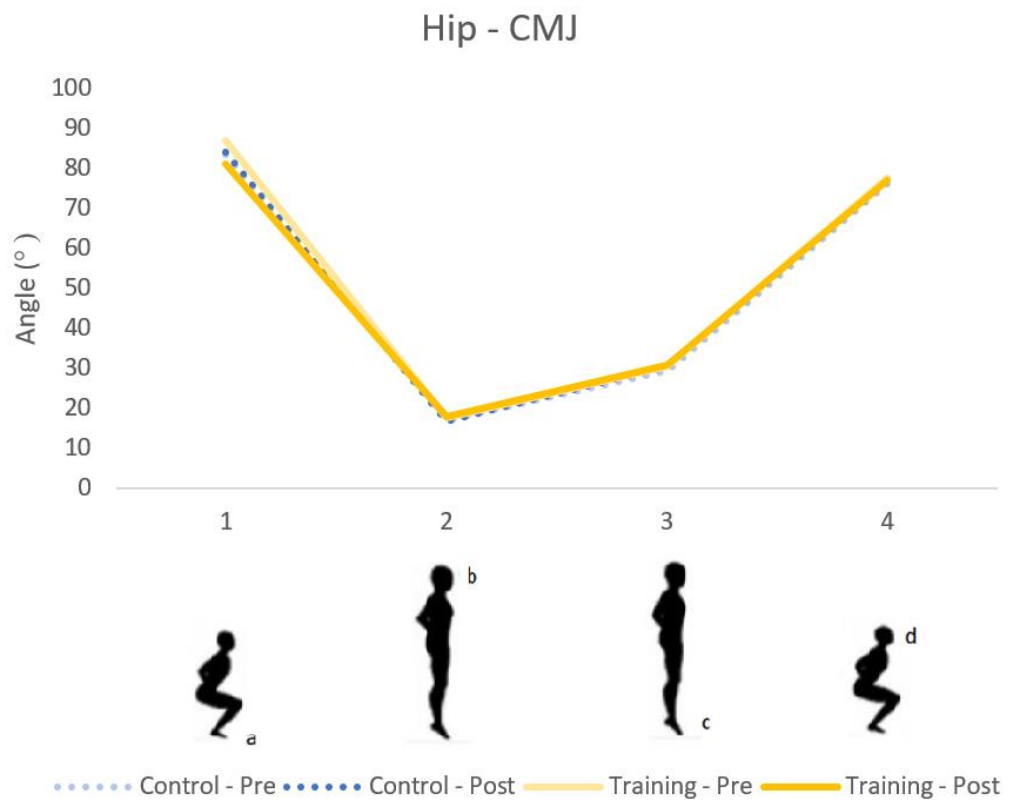

Figure 48: Hip angle variation during CMJ phases.

Likewise, the Knee Angle in the CMJ Preparatory Squat, the Knee Angle in the SJ Preparatory Squat was also statistically different between Training and Control conditions in the Pre-test. However, differently than the results obtained in the CMJ, the intervention did not cause any modification either in the Training or the Control conditions. Therefore, no adjustments occurred and the difference between the Training and the Control conditions remained significant in the Post-test (average \pm SD [$^{\circ}$] - T Pre-Test: 76.6 ± 12.1 , Post-Test 72.3 ± 14.7 - C Pre-test: 89.3 ± 13.6 , Post-test 94.6 ± 7.6).

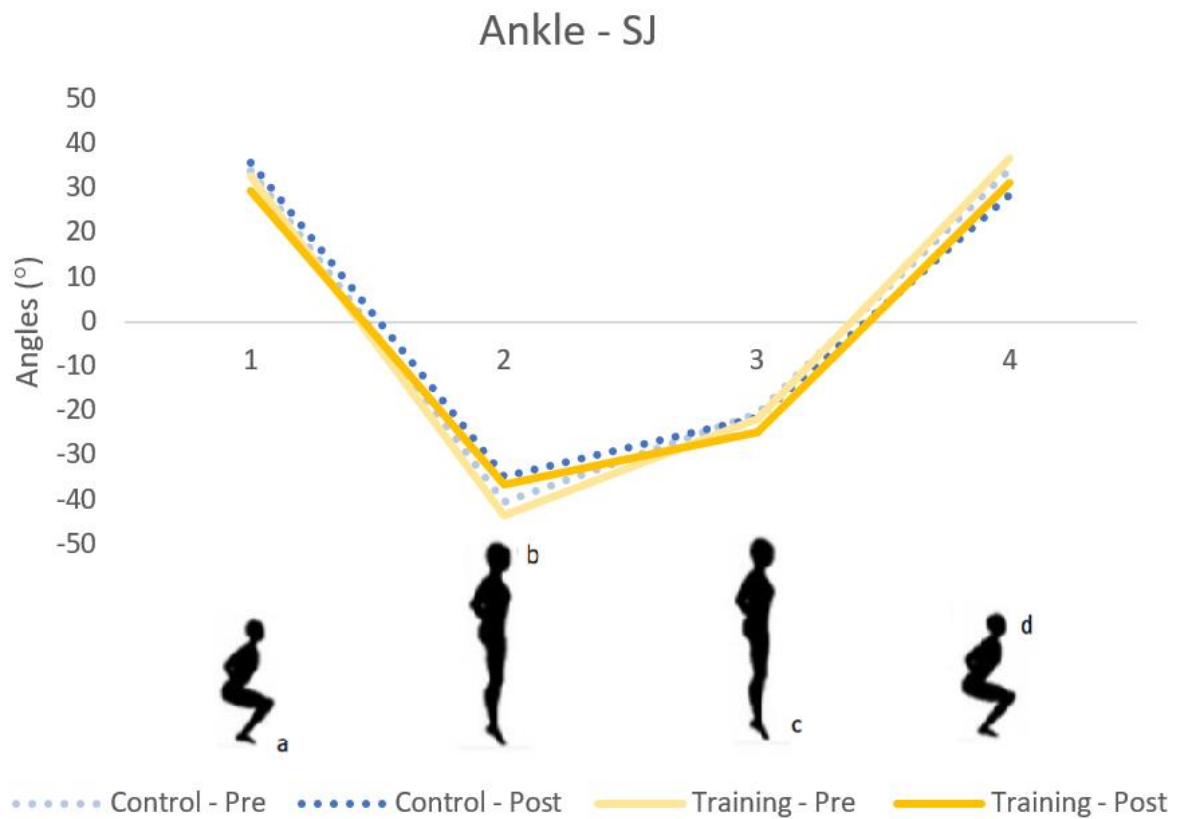

Figure 49: Ankle angle variation during SJ phases.

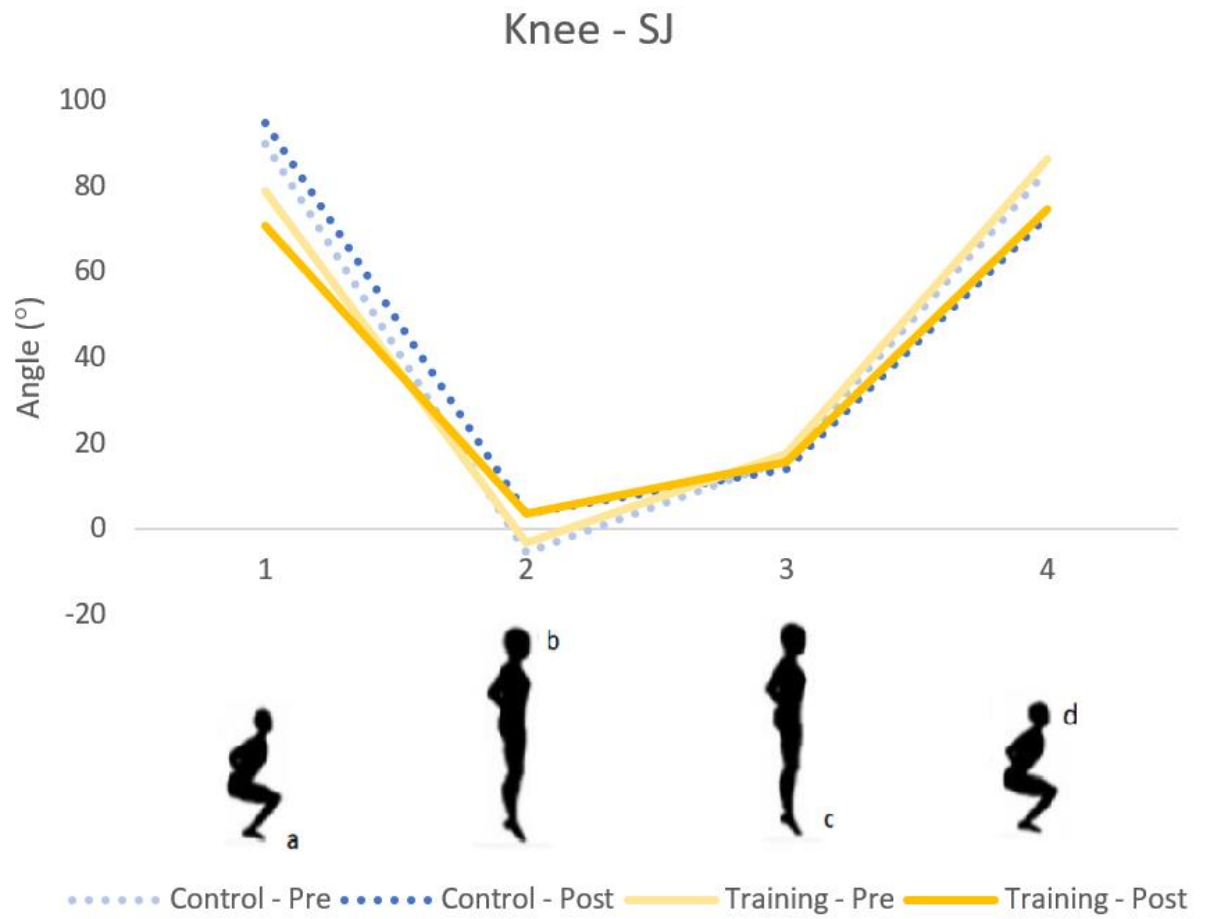

Figure 50: Knee angle variation during SJ phases.

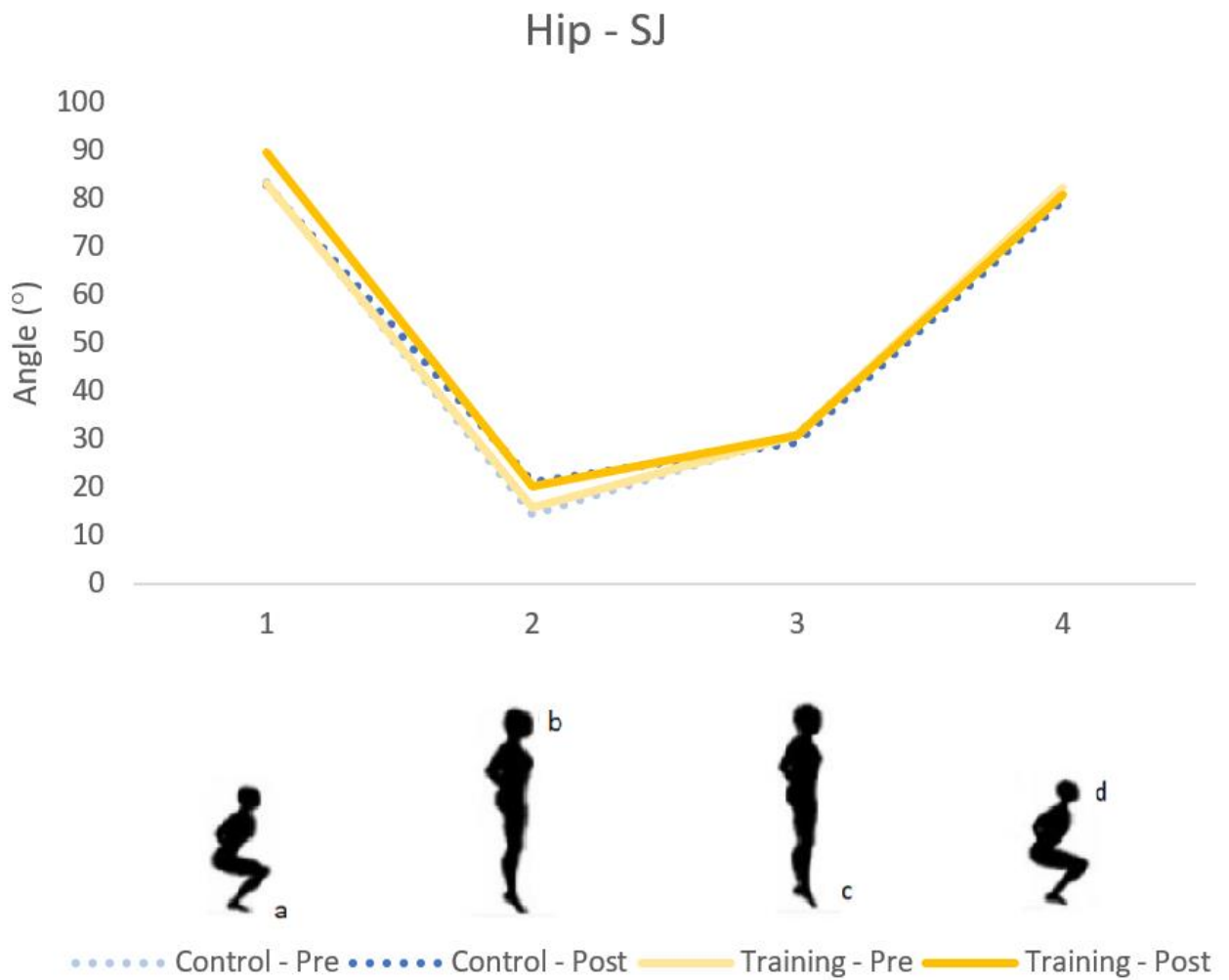

Figure 51: Hip angle variation during SJ phases.

7.4.3 Vertical jumps angular velocity at eccentric phase: Condition (Training and Control) and Time (Pre- and Post-test) comparisons

Tables 44 and 45 show the descriptive analysis of CMJ and SJ, respectively, eccentric and concentric angular velocities followed by Table 46 presenting the ANOVA repeated measures (when parametric) and Friedman (when non-parametric) comparing condition vs time of the angular velocities at each joint.

Table 44: Descriptive statistics of CMJ angular velocities in degrees per second (average \pm standard deviation)

Jump	Joint	Phase	Condition	Time	Average	SD
CMJ	Ankle	Angular Velocity Eccentric	Training	Pre-Test	149.7	121.4
				Post-test	168.6	156.7
			Control	Pre-Test	118.4	50.2
				Post-test	112.9	46.9

		Angular Velocity Concentric	Training	Pre-Test	-1322.8	244.1
				Post-test	-1276.8	324.7
			Control	Pre-Test	-1342.7	213.2
				Post-test	-1232.8	170.5
	Hip	Angular Velocity Eccentric	Training	Pre-Test	274.1	66.3
				Post-test	267.5	135.7
			Control	Pre-Test	261.2	56.7
				Post-test	248.5	105.1
		Angular Velocity Concentric	Training	Pre-Test	-550.2	70.6
				Post-test	-523.2	87.7
	Control	Pre-Test	-542.8	103.9		
		Post-test	-527.9	77.1		
Knee	Angular Velocity Eccentric	Training	Pre-Test	270.9	68.5	
			Post-test	229.2	49.0	
		Control	Pre-Test	268.4	65.6	
			Post-test	236.1	52.6	
	Angular Velocity Concentric	Training	Pre-Test	-953.0	102.6	
			Post-test	-897.8	138.3	
Control	Pre-Test	-952.7	201.3			
	Post-test	-934.7	181.8			

CMJ: Countermovement jump, SD: Standard deviation.

Table 45: Descriptive statistics of SJ angular velocities in degrees per second (average \pm standard deviation)

Jump	Joint	Phase	Condition	Time	Average	SD
SJ	Ankle	Angular Velocity Eccentric	Training	Pre-Test	87.0	26.4
				Post-test	75.0	19.7
			Control	Pre-Test	76.2	19.7
				Post-test	68.8	17.5
		Angular Velocity Concentric	Training	Pre-Test	-490.1	98.1
				Post-test	-512.2	140.5
	Control	Pre-Test	-1383.7	217.4		
		Post-test	-1284.2	177.4		
	Hip	Angular Velocity Eccentric	Training	Pre-Test	207.8	51.2
				Post-test	192.1	56.0
			Control	Pre-Test	183.8	43.8
				Post-test	177.4	33.5
		Angular Velocity Concentric	Training	Pre-Test	-902.8	110.4
				Post-test	-932.5	226.0
	Control	Pre-Test	-436.8	213.3		
		Post-test	-523.8	132.5		
	Knee	Angular Velocity Eccentric	Training	Pre-Test	178.8	17.2
				Post-test	180.0	45.1
Control			Pre-Test	190.7	40.6	
			Post-test	193.2	88.5	
Angular Velocity Concentric		Training	Pre-Test	-140.7	58.3	
			Post-test	-177.4	46.8	
Control	Pre-Test	-914.9	283.7			
	Post-test	-840.1	152.4			

SJ: Countermovement jump, SD: Standard deviation.

Table 46: Vertical jumps ANOVA repeated measures with pairwise comparisons (when parametric) and Friedman with Wilcoxon comparisons (when non-parametric) of Ankle, Hip and Knee angular velocities in degrees per second.

			Pre-Test Training vs Pre-Test Control	Post-Test Training vs Post-Test Control	Pre-Test Training vs Post-Test Training	Pre-Test Control vs Post-Test Control	Main effect
CMJ	Angular Velocity Eccentric	Ankle Angle	-	-	-	-	0.980
		Hip Angle	-	-	-	-	0.057
		Knee Angle	0.689	0.336	0.028	0.041	$F_{4.875} P=0.006; \eta^2_p=0.307; \beta=0.870$
	Angular Velocity Concentric	Ankle Angle	0.480	0.001	0.001	0.312	$F_{83.708} P=0.001; \eta^2_p=0.893; \beta=1.000$
		Hip Angle	0.951	0.492	0.261	0.443	$F_{0.806} P=0.435; \eta^2_p=0.068; \beta=0.154$
		Knee Angle	0.980	0.301	0.146	0.779	$F_{0.656} P=0.530; \eta^2_p=0.052; \beta=0.148$
SJ	Angular Velocity Eccentric	Ankle Angle	0.169	0.210	0.520	0.774	$F_{1.060} P=0.367; \eta^2_p=0.105; \beta=0.207$
		Hip Angle	-	-	-	-	0.414
		Knee Angle	-	-	-	-	0.819
	Angular Velocity Concentric	Ankle Angle	0.001	0.001	0.503	0.554	$F_{150.201} P=0.001; \eta^2_p=0.962; \beta=1.000$
		Hip Angle	0.004	0.001	0.614	0.379	$F_{17.267} P=0.001; \eta^2_p=0.742; \beta=1.000$
		Knee Angle	-	-	-	-	0.001

CMJ: Countermovement jump, SJ: Squat jump, Grey cells: non-parametric analyses. White cells: parametric analyses. Variables in light: not statistically significant. Variables in bold: statistically significantly different. - : No main effect, therefore no further comparisons required.

Table 47 presents the average and standard deviation of the Angular Velocity for all the joints (Ankle, Hip and Knee) at the Eccentric and Concentric phase of the CMJ and SJ.

Table 47: Average and standard deviation of CMJ and SJ Ankle, Hip and Knee angular velocity at the eccentric and concentric phases in degrees per second.

			Pre-Test Training	Post-Test Training	Pre-Test Control	Post-Test Control
CMJ	Angular Velocity Eccentric	Ankle Angle	149.7 ± 121.4	168.6 ± 274.1	118.4 ± 50.2	112.9 ± 46.9
		Hip Angle	274.1 ± 66.3	267.5 ± 135.7	261.2 ± 56.7	248.5 ± 105.1
		Knee Angle	270.9 ± 68.5*	229.2 ± 49.0*	268.4 ± 65.6*	236.1 ± 52.6*
	Angular Velocity Concentric	Ankle Angle	-1322.8 ± 244.1*	-1276.8 ± 324.7**	-1342.7 ± 213.2	-1232.8 ± 170.5#
		Hip Angle	-550.2 ± 70.6	-523.9 ± 87.7	-542.8 ± 103.9	-527.9 ± 77.1
		Knee Angle	-953.0 ± 102.6	-897.8 ± 138.3	-952.7 ± 201.3	-934.7 ± 181.8
SJ	Angular Velocity Eccentric	Ankle Angle	87.0 ± 26.4	75.0 ± 19.7	76.2 ± 19.7	68.8 ± 17.5
		Hip Angle	207.8 ± 51.2	192.1 ± 56.0	183.8 ± 43.8	177.4 ± 33.5
		Knee Angle	178.8 ± 17.2	180.0 ± 45.1	190.7 ± 40.6	193.2 ± 88.5
	Angular Velocity Concentric	Ankle Angle	-490.1 ± 98.1#	-512.2 ± 140.5#	-1383.7 ± 217.4#	-1284.2 ± 177.4#
		Hip Angle	-902.9 ± 110.4#	-932.5 ± 226.0#	-436.8 ± 213.3#	-525.8 ± 132.5#
		Knee Angle	-140.7 ± 58.3*#	-177.4 ± 46.8*#	-914.4 ± 283.7#	-840.1 ± 152.4#

CMJ: Countermovement jump, SJ: Countermovement jump. Variables in light: not statistically significant. Variables in bold: statistically significantly different. * Statistically significant difference between time points (Pre- and Post-test). # Statistically significant difference between conditions (Training and Control).

7.4.4 EMG_{RF}: Condition (Training and Control) and Time (Pre- and Post-test) comparisons

Tables 48 and 49 show the descriptive analysis of the Rectus femoris and Semitendinosus EMG, respectively, during the vertical jumps followed by Table 50 presenting the ANOVA repeated measures (when parametric) and Friedman (when non-parametric) comparing condition vs time of the Semitendinosus and Rectus Femoris relative EMG i.e. Ratio of EMG Peak/EMG Rest. EMG activity was similar between the limbs and did not change with stretch intervention.

Table 48: Descriptive statistics of Rectus Femoris EMG activity (mV) (average \pm standard deviation)

			Pre-test	Post-test
CMJ	Training	EMG_{RF} Peak	1.60E-04 \pm 4.45E-05	1.63E-04 \pm 3.72E-05
		EMG_{RF} Rest	2.32E-06 \pm 7.66E-07	3.76E-06 \pm 2.89E-06
		EMG_{RF} Ratio	7.82E+07 \pm 3.44E+07	6.43E+07 \pm 3.38E+07
	Control	EMG_{RF} Peak	1.56E-04 \pm 5.59E-05	1.51E-04 \pm 4.31E-05
		EMG_{RF} Rest	3.11E-06 \pm 2.22E-06	2.70E-06 \pm 9.40E-07
		EMG_{RF} Ratio	7.67E+07 \pm 5.46E+07	7.26E+07 \pm 4.98E+07
SJ	Training	EMG_{RF} Peak	1.52E-04 \pm 5.08E-05	1.40E-04 \pm 8.74E-05
		EMG_{RF} Rest	3.24E-06 \pm 1.53E-06	2.19E-06 \pm 3.85E-07
		EMG_{RF} Ratio	6.07E+07 \pm 3.80E+07	7.03E+07 \pm 5.16E+07
	Control	EMG_{RF} Peak	1.43E-04 \pm 5.68E-05	1.84E-04 \pm 9.09E-05
		EMG_{RF} Rest	3.69E-06 \pm 2.38E-06	2.14E-06 \pm 4.35E-07
		EMG_{RF} Ratio	4.90E+07 \pm 2.50E+07	8.86E+07 \pm 4.00E+07

CMJ: Countermovement jump, SJ: Countermovement jump, EMG: electromyographic activity, RF: Rectus femoris, Ratio: peak/rest.

Table 49: Descriptive statistics of Semitendinosus EMG activity (mV) (average \pm standard deviation)

			Pre-test	Post-test
CMJ	Training	EMG_{ST} Peak	6.72E-05 \pm 1.75E-05	9.96E-05 \pm 8.27E-05
		EMG_{ST} Rest	3.80E-06 \pm 1.51E-06	4.36E-06 \pm 1.49E-06
		EMG_{ST} Ratio	2.01E+07 \pm 8.19E+06	2.07E+07 \pm 8.93E+06
	Control	EMG_{ST} Peak	7.18E-05 \pm 2.41E-05	3.06E-04 \pm 5.58E-04
		EMG_{ST} Rest	3.75E-06 \pm 1.64E-06	4.94E-06 \pm 2.33E-06
		EMG_{ST} Ratio	2.22E+07 \pm 1.11E+07	4.94E+07 \pm 7.47E+07
SJ	Training	EMG_{ST} Peak	1.21E-04 \pm 1.05E-04	1.25E-04 \pm 6.32E-05
		EMG_{ST} Rest	4.23E-06 \pm 1.35E-06	3.59E-06 \pm 1.25E-06
		EMG_{ST} Ratio	2.72E+07 \pm 1.86E+07	3.93E+07 \pm 2.54E+07
	Control	EMG_{ST} Peak	9.52E-05 \pm 4.71E-05	8.64E-05 \pm 5.36E-05
		EMG_{ST} Rest	4.64E-06 \pm 2.54E-06	2.58E-06 \pm 1.41E-07
		EMG_{ST} Ratio	3.44E+07 \pm 3.67E+07	3.36E+07 \pm 2.11E+07

CMJ: Countermovement jump, SJ: Countermovement jump, EMG: electromyographic activity, ST: Semitendinosus, Ratio: peak/rest.

Table 50: Vertical jumps ANOVA repeated measures with pairwise comparisons (when parametric) and Friedman with Wilcoxon comparisons (when non-parametric) of relative (i.e. ratio) EMG during vertical jumps

			Pre-Test Training vs Pre-Test Control	Post-Test Training vs Post-Test Control	Pre-Test Training vs Post-Test Training	Pre-Test Control vs Post-Test Control	Main effect
EMG	CMJ	Rectus Femoris	0.522	0.692	0.607	0.560	<i>F</i> _{0.177} <i>P</i> =0.910; η^2_p =0.034; β =0.076
		Semitendinosus	0.702	0.380	0.881	0.414	<i>F</i> _{0.806} <i>P</i> =0.415; η^2_p =0.848; β =0.116
	SJ	Rectus Femoris	-	-	-	-	0.389
		Semitendinosus	0.247	0.758	0.969	0.678	<i>F</i> _{0.226} <i>P</i> =0.786; η^2_p =0.070; β =0.071

CMJ: Countermovement jump, SJ: Squat jump, Grey cells: non-parametric analyses. White cells: parametric analyses. Variables in light: not statistically significantly different. Variables in bold: statistically significantly different. -: not applicable analysis.

7.4.5 Vertical jumps joint angles: Δ Time [(Post-Pre)/Pre] and Condition (Training and Control) comparisons

Table 51 shows the Conditions' comparison of the difference ratio of angle joints.

Table 51: Paired t-tests (when parametric) or Wilcoxon (when non-parametric) of the Δ Joint angles between the C and T conditions (%)

			Average	SD	SEM	<i>P</i>
Preparatory Squat	CMJ	Δ Ankle Angle T	-2%	24%	7%	0.276
		Δ Ankle Angle C	10%	27%	8%	
		Δ Hip Angle T	-5%	37%	9%	0.190
		Δ Hip Angle C	-7%	30%	7%	
		Δ Knee Angle T	-13%	25%	7%	0.580
	Δ Knee Angle C	27%	21%	6%		
	SJ	Δ Ankle Angle T	-5%	28%	7%	0.480
		Δ Ankle Angle C	10%	26%	7%	
		Δ Hip Angle T	13%	24%	6%	0.756
		Δ Hip Angle C	1%	18%	5%	
Δ Knee Angle T		-20%	61%	16%	0.104	
Δ Knee Angle C	219%	759%	196%			
Take-off	CMJ	Δ Ankle Angle T	70%	505%	126%	0.165
		Δ Ankle Angle C	84%	329%	85%	
		Δ Hip Angle T	26%	63%	16%	0.002
		Δ Hip Angle C	40%	93%	24%	
		Δ Knee Angle T	-3%	63%	16%	0.151
	Δ Knee Angle C	5%	80%	20%		
	SJ	Δ Ankle Angle T	-18%	57%	15%	0.001
		Δ Ankle Angle C	-15%	54%	14%	
		Δ Hip Angle T	20%	103%	27%	0.001
		Δ Hip Angle C	69%	223%	58%	
Δ Knee Angle T		41%	195%	50%	0.467	
Δ Knee Angle C	-11%	36%	9%			
Landing	CMJ	Δ Ankle Angle T	-8%	26%	6%	0.420
		Δ Ankle Angle C	9%	26%	7%	
		Δ Hip Angle T	7%	37%	10%	0.742
		Δ Hip Angle C	-11%	64%	18%	
		Δ Knee Angle T	8%	15%	4%	0.368

Landing Squat	SJ	Δ Knee Angle C	-25%	65%	17%	0.404
		Δ Ankle Angle T	-204%	581%	150%	
		Δ Ankle Angle C	-206%	606%	156%	
		Δ Hip Angle T	2%	37%	10%	0.862
		Δ Hip Angle C	-10%	48%	13%	
		Δ Knee Angle T	8%	86%	23%	0.001
	Δ Knee Angle C	-1%	51%	14%		
	Δ Ankle Angle T	21%	103%	29%	0.780	
	CMJ	Δ Ankle Angle C	16%	68%		19%
		Δ Hip Angle T	7%	50%	14%	0.960
		Δ Hip Angle C	6%	52%	14%	
		Δ Knee Angle T	-13%	78%	20%	0.318
Δ Knee Angle C		29%	197%	51%		
SJ		Δ Ankle Angle T	-4%	50%	13%	0.452
	Δ Ankle Angle C	37%	161%	41%		
	Δ Hip Angle T	5%	15%	4%	0.111	
	Δ Hip Angle C	-2%	26%	7%		
	Δ Knee Angle T	-13%	38%	10%	0.428	
	Δ Knee Angle C	-8%	26%	7%		

SD: standard deviation, SEM: standard error of the mean, *P*: level of significance obtained, Δ: delta, T: trained, C: control, CMJ: countermovement jump, SJ: squat jump. Grey lines: non-parametric analyses. White lines: parametric analyses. Variables in light: not statistically significant. Variables in bold: statistically significantly different.

7.4.6 Vertical jumps angular velocity: Δ Time [(Post-Pre)/Pre] and Condition (Training and Control) comparisons

Table 52 shows the Conditions' comparison of the difference ratio of angular velocities.

The only limb difference was in SJ hip angular velocity at the eccentric phase.

Table 52: Paired t-tests (when parametric) or Wilcoxon (when non-parametric) of the Δ angular velocity between C and T conditions (%)

				Average	SD	SEM	<i>P</i>
CMJ	Angular Velocity	Eccentric	Δ Ankle T	41.23	145.69	40.40	0.449
			Δ Ankle C	0.80	18.44	5.56	
			Δ Hip T	-1.52	45.15	12.06	0.428
			Δ Hip C	-6.38	28.81	7.70	
			Δ Knee T	-12.22	12.55	3.62	0.171
		Δ Knee C	-8.64	14.14	4.08		
		Concentric	Δ Ankle T	0.38	25.74	7.13	0.042
			Δ Ankle C	-2.39	7.65	2.30	
			Δ Hip T	-5.04	16.02	4.62	0.001
			Δ Hip C	-2.31	18.79	5.42	
Δ Knee T	-6.03		14.51	4.02	0.055		
Δ Knee C	0.85	20.93	5.80				
SJ	Angular Velocity	Eccentric	Δ Ankle T	-3.53	16.32	5.16	0.001
			Δ Ankle C	-0.30	24.23	7.66	
			Δ Hip T	-6.19	22.44	6.48	0.326
			Δ Hip C	5.98	33.62	11.20	
			Δ Knee T	-5.11	24.01	7.59	0.500
		Δ Knee C	1.86	28.88	8.70		
		Concentric	Δ Ankle T	-2.73	12.29	4.64	0.961
			Δ Ankle C	-1.46	7.78	2.94	

			Δ Hip T	6.67	14.98	5.29	0.344
			Δ Hip C	686.84	1805.88	682.56	
			Δ Knee T	22.57	48.61	17.18	0.156
			Δ Knee C	-0.55	14.56	7.85	

SD: standard deviation, SEM: standard error of the mean, *P*: level of significance obtained, Δ : delta, T: trained, C: control, CMJ: countermovement jump, SJ: squat jump. Grey lines: non-parametric analyses. White lines: parametric analyses. Variables in light: not statistically significant. Variables in bold: statistically significantly different.

7.4.7 Vertical jumps EMG: Δ Time [(Post-Pre)/Pre] and Condition (Training and Control) comparisons

Table 53 shows the Conditions' comparison of the difference ratio of EMG. No difference between condition (Training and Control) or time (Pre- and Post-test) was found.

Table 53: Paired t-tests (when parametric) and Wilcoxon (when non-parametric) of the Δ EMG between the C and T conditions

			Average	SD	SEM	<i>P</i>
EMG	CMJ	Δ EMG _{RF} T	0%	76%	31%	0.344
		Δ EMG _{RF} C	64%	156%	64%	
	SJ	Δ EMG _{RF} T	8%	85%	38%	0.063
		Δ EMG _{RF} C	107%	125%	62%	
EMG	CMJ	Δ EMG _{ST} T	31%	76%	31%	0.500
		Δ EMG _{ST} C	102%	236%	96%	
	SJ	Δ EMG _{ST} T	18%	79%	39%	0.063
		Δ EMG _{ST} C	60%	82%	41%	

SD: standard deviation, SEM: standard error of the mean, *P*: level of significance obtained, Δ : delta, T: trained, C: control, CMJ: countermovement jump, SJ: squat jump. Grey lines: non-parametric analyses. White lines: parametric analyses. Variables in light: not statistically significant. Variables in bold: statistically significantly different.

7.4.6 Hormonal concentration (Oestrogen and Progesterone) correlations with all dependent variables: Condition (Training and Control) and Time (Pre- and Post-test) comparisons

Table 54 shows the significant correlation between the hormone concentration and Δ of the dependent variables⁴⁹. Oestrogen was significantly correlated with five out of 40 relative changes in jump kinetic outcome measures whereas progesterone was only correlated with four of these relative change variables.

Table 54: Significant correlation results

	Oestrogen	Progesterone
Δ CMJ Hip Angular velocity Concentric	<i>P</i> = 0.032 <i>r</i> = 0.393*	-
Δ CMJ EMG _{ST}	-	<i>P</i> = 0.015 <i>r</i> = 0.650*
Δ SJ EMG _{ST}	<i>P</i> = 0.022 <i>r</i> = 0.719*	-

⁴⁹ Complete correlation table Appendix K page 307

Δ SJ EMG _{RF}	$P = 0.038$ $r = 0.619^*$	-
Δ SJ Knee Angular velocity Eccentric	-	$P = 0.032$ $r = 0.444^*$
Δ SJ Ankle Angular velocity Eccentric	$P = 0.032$ $r = -0.446^*$	-
Δ SJ Ankle Angle – Take-off	$P = 0.038$ $r = 0.347^*$	-
Δ SJ Ankle Angle – Landing Squat	$P = 0.017$ $r = 0.410^*$	-

CMJ: Countermovement jump. SJ: Squat jump. P = significance level. * = $P < 0.05$. r = correlation. -: not applicable analysis. Δ : delta (Post-Pre)/Pre. EMG: Electromyography. RF: Rectus femoris. ST: Semitendinosus.

7.5 Discussion

The primary aim of this chapter was to assess whether any level of asymmetry in flexibility between the lower limbs may affect the kinematics of vertical jumps; secondly, to evaluate any influence of unilateral stretch session in the same variables. The alternative hypothesis was that dancers would present asymmetries in flexibility between the limbs and these asymmetries would affect joint angles. Results of Chapter 3 confirmed that dancers presented asymmetries in the ROM_{Max}, torque_{Max}, but these asymmetries did not appear to affect S_{MTU} and thus jump performance. In the current chapter, despite asymmetries in ROM_{Max} and torque_{Max}, asymmetries were observed only in the Knee Angle of the Preparatory Squat for both CMJ and SJ. Additionally, the intervention did not cause differences in the SJ angles whilst for the CMJ it affected both Control and Training limbs. Furthermore, the intervention decreased the asymmetry between limbs for the CMJ but not for the SJ. No modifications were seen in any other joint angle analysed through the comparison of the Pre-test between the limbs (here known as either Control or Training limb).

The Angular Velocity analysis showed modification in two out of six variables for the CMJ and three out of six for the SJ. Differently than the angle analysis, asymmetries were not found between Training and Control in the Knee joint; the after intervention the angular velocities in the Eccentric phase decreased in both limbs. However, the Ankle Angular Velocity in the Concentric Phase of the CMJ in the Training limb was smaller after the intervention just in the Trained limb. No other variable seemed to differ. For the SJ, the only differences were observed in the Concentric phase of the jump. These differences, however, were mainly between limbs, not caused by training. The only exception was for the Knee Angular Velocity that also presented differences caused by intervention. Results indicate that asymmetries in the flexibility may not directly affect the kinematic variables of the vertical jumps.

The second alternative hypothesis was that the unilateral stretch of the most flexible limb would cause or increase any imbalances already existent and further affect the jump kinematics. This hypothesis was partially rejected since stretching the most flexible limb did not increase the intervention limb's flexibility. However, unilateral stretching caused changes in Knee angle asymmetries for the CMJ where these were previously existent (increase in Control and decrease in Training conditions).

No statistical differences were found in the CMJ and SJ kinematic analysis for the ankle, hip and knee angles in any of the phases except for the Knee angle at the Preparatory Squat of CMJ and SJ. This is true whether we consider the comparison between Control and Training conditions, or we consider before against after phases of the stretch intervention (Pre- and Post-test). These results confirm that participants executed a good jump' technique. Indeed, maintaining the hip and knees extended and the ankle plantarflexed at take-off phase is part of a good jump's requirement in many dance steps (Orishimo et al., 2014, Liederbach et al., 2014, Orishimo et al., 2009). In addition, the lack of difference in the SJ angles at Preparatory Squat Pre- and Post-test confirms that the same angle was reached and maintained before all jumps.

It was expected that the hip would be more flexed after the stretch intervention to reach a pre-identified torque level due to the bigger ROM in the limb subjected to the intervention (Herda et al., 2014, Magnusson et al., 1996a, Ylinen et al., 2009). However, no modification in the hip joint was observed in the Post-test compared to Pre-test neither for the CMJ nor for the SJ. Furthermore, no differences were found between conditions. This result suggests that dancers must have produced less strength in the Post-test and reached lower height in the jump, corroborating previous literature that found a decrease in the jump height after stretching protocols (Herda et al., 2008, Morrin and Redding, 2013). However, according to results found in Chapter 3, no differences between Pre- and Post-test were observed for CMJ Jump Height neither for the CMJ total force_{peak} nor CMJ force_{peak} in each limb. When analysing the SJ results also from Chapter 3, it is apparent that the SJ total force_{peak} in the Post-test were smaller than in the Pre-test. Although no difference in the SJ Jump Height was seen, these results all together indicate that greater intensities of stretch might indeed,

affect the variables analysed in this study, but the four series of 30-seconds with constant torque at 90% of the maximum ROM tolerated, in only one limb, does not appear to have been sufficient to affect the aforementioned variables. Corroborating this assumption, previous work (Pessali-Marques et al., 2016) suggested that more flexible participants would need more series of stretching to allow tissue accommodation than less flexible participants. Finally, no differences were found in the ankle angles between the Pre- and Post-test or between conditions. This finding corroborates the nonblack of effect in the other joints. Indeed, given that the analysed joints are linked to each other by the same body segments, a cascade response would therefore be expected.

In two out of 48 CMJ and SJ outcome measures comparing Pre- and Post-test, there was a significant impact of intervention on the jump kinematics only in the Knee Angle in the Preparatory Squat. Interestingly, of the few significant outcomes, one occurred in the Control limb, which was unexpected given this limb did not undergo any intervention. This result highlights possible influence of intervention in the Training limb but also to the contralateral Control limb. The degree of flexion of the Knee Angle during the CMJ Preparatory Squat phase decreased significantly in the Post-test for Training condition but increased for Control condition. Whilst a statistically significant difference between Training and Control condition was found in the Pre-test, this difference was not statistically significant in the Post-test. This result corroborates with the aforementioned assumption that adjustments in the Control limb may happen, even when the limb did not undergo to direct training. However, given that Control and Training conditions are limbs of the same individual, the Central Nervous System may have played a role in these adjustments (Figure 47).

Although not statistically significantly different in the SJ, similar responses to those seen in the CMJ also occurred in the SJ, in which the degree of Knee flexion decreased in the Post-test for the Training condition but increased for the Control condition. This behaviour was not expected, given that any increase in the Knee angle was expected only in the limb that underwent the intervention. Not only the Training condition did not show statistical changes between Pre- and Post-test, but also showed decrease in the angles, whilst the Control condition presented significant increases in angles.

The Angular Velocity analysis showed modification in only two out of six variables for the CMJ, and three out of six for the SJ. In the CMJ Eccentric phase, the intervention did not affect the Training limb when Pre- and Post-test were compared neither for the Ankle nor for the Hip, but it decreased Knee Angular Velocities. Nevertheless, the decrease was seen in both limbs, not only in the trained one. For the Control condition, this decrease in the Post-test was not expected again as previously emphasised, given that the Control condition did not undergo any stretch intervention. In the CMJ Concentric phase, the only difference in the Angular Velocity was seen in the Ankle Angular Velocity. Due to the decrease in the Training limb Angular Velocity the comparison between groups showed an increase in asymmetry between limbs after intervention. Given that this was the only variable which accepted the alternative hypothesis of this study, that stated that intervention in only one limb could increase asymmetries between limbs, these results, intriguingly, highlight the attempt of the body to correct any asymmetry already existent in the body. In the SJ there was no differences in the Eccentric phase neither between time nor groups. The Concentric phase, however, showed smaller Angular Velocity for all the joints in the Training limb, even though, the intervention was only significant in the Knee Angular Velocity.

The fact that more adjustments aiming to decrease asymmetries happened in the CMJ than in the SJ suggests that these adjustments may be more efficient when the body is in constant movement rather than in a static position. Supporting this statement, no statistically significant differences between limbs (conditions) were found in any other CMJ and SJ time or phase. Regarding the non-modification in the joint angles after intervention, suggests that acute modifications in the hamstrings ROM_{Max} (Chapter 3) might not be enough to affect ankle, hip and knee angles during the CMJ and SJ. This result corroborate with the aforementioned assumption that adjustments in the Control limb may happen, even when the limb did not directly undergo training, but given that Control and Training conditions are limbs of the same individual, the Central Nerve System (CNS) may have played a role in these adjustments and this is expanded upon below.

It was seen in previous literature that the CNS anticipates segmental body geometry changes and mechanical effects of the movement dynamics, impacting on body orientation and

postural balance. Postural needs are established in the beginning of the vertical jumps; therefore, the CNS takes these needs into account to program the movement. With the increased practice of the same movement required by each sport modality (such as flexibility and jumps for dance), the coordination program of the vertical jumping model is so highly practiced that it has become an automatic reflex-like movement named skill-reflex. Therefore, the programmed skill-reflex seems to guide the execution of the jump (Eloranta, 1997). The specific prolonged training will cause the CNS to program muscle coordination according to the demands of that movement. However, the learned skill-reflex of the CNS seems to interfere hierarchically in the performance program of another task (Eloranta, 2003). The skill-reflex might be one possible explanation why the body tries to correct the asymmetries in both limbs during the vertical jumps, even when only one limb is subjected to intervention, and, why the intervention might not have affected immediately the jump performance. Strengthening this rationale previous authors (Volkerding and Ketcham, 2013) compared dancers and non-dancers performing drop jumps and concluded that dancers utilize the proprioceptive input more effectively controlling the hip flexion to maintain stability.

Corroborating the participation of the CNS in vertical jumps and the effect of different intervention in performance, a study that evaluated the ergogenic advantage associated with incorporated resistance training and plyometric training, justified their hypothesis in the idea of possible heightened excitability of the CNS (Jensen and Ebben, 2003). The authors, however, did not find enhancement in plyometric performance straight after resistance training.

Elite athletes are suggested to have higher sensitivity of muscle receptors and the CNS, highlighting the importance of the increased excitability of peripheral sense organs and the CNS to possible positive effects on the subsequent movements (Issurin and Tenenbaum, 1999). This study, however, focused on the effects of vibratory stimulation on explosive strength in elite and amateur athletes. The relationship between the sensory and biomechanical properties of the muscle has been discussed in previous research on flexibility (Cabido et al., 2014, Pessali-Marques, 2015, Chagas et al., 2016). However, the influence of the sensory property in subsequent movements (such as jumps) still needs to be clarified.

The EMG for both Semitendinosus and Rectus femoris showed no difference in the activation between condition and time phase in the current research. Additionally, results of Chapter 3 did not find any difference in either the CMJ or SJ Jump Height. These results contradict previous study that verified the acute effect of stretching on the kinematics of the vertical jump in a heterogeneous sample of 20 young adults and did not find significant changes in vertical velocity, knee angle, or the durations of the eccentric and concentric phases (Knudson et al., 2001). The authors concluded that stretching prior to vertical jump results in small decreases in performance in some subjects and that the non-significant biomechanical changes were due to neuromuscular inhibition rather than changes in muscle stiffness. Previous authors (Knudson et al., 2001) justified the decrease in the jump performance to the decrease in S_{MTU} . Whilst, the authors did not measure stiffness, they have proposed that a decrease in stiffness may have happened if the knee angle had increased or the duration of the eccentric and concentric actions had increased. In addition, the authors collected data from 10 males and 10 females and, although, exhibiting a high data variability, especially in the vertical velocity, no information about menstrual cycle phase of the female participants was given. The menstrual cycle phase information is required to decrease any possible hormonal influence due to the variation of female hormones across the phases. Chapter 5 of the current thesis is aimed to assess the variation of oestrogen, progesterone and relaxin across the cycle and their effect at the variables of the jump and flexibility. Finally, these authors used three series of 15 seconds of passive static stretch with constant angle and did not control the intensity of the stretch. Previous research has Cabido et al. (2014), (Herda et al., 2011b) compared 'constant angle and constant torque' passive stretching, and found a decrease in stiffness only after the constant torque protocol. The intensity and the type of passive stretching applied may have played a role in the lack of modification in stiffness.

Comparison between the change relative to baseline (delta: [Post-Pre]/Pre) between conditions showed statistical difference only for (1) the CMJ Hip angle at Take-off, with the Training limb being less flexed than the Control limb, (2) the SJ Ankle angle at Take-off, with also the Training limb being more plantarflexed than the Control limb, (3) the SJ Hip angle at Take-off, with the Training limb being less flexed than the Control limb and (4) the SJ Knee

angle at Landing, with the Training limb being less flexed than the Control limb. These results contradict the greater ROM achieved after the stretch intervention in the trained limb in previous study (Davis et al., 2005). The CMJ, Hip and Knee Angular Velocity in the Concentric phase were different between conditions, in which the Control condition reached greater angular velocity in the Ankle but smaller in the Hip and Knee. Contrary, for the SJ, the only difference was seen in the Eccentric phase, where the Ankle Angular Velocity was smaller in the Training compared to Control.

Lastly, Oestrogen and Progesterone concentrations were correlated with the dependent variables and results contradict those found in Chapter 3. Given that Progesterone has a tightening effect (Heitz et al., 1999), an increase in its concentration was expected to decrease the angles. However, Progesterone was not correlated to any of the angle variables, but it was intriguingly positively correlated with CMJ EMG_{ST} and SJ EMG_{RF}. Regarding Oestrogen levels, an increase in Oestrogen levels would increase the angles due to its loosening effect (Magnusson et al., 2007), but that was only noticed in SJ Ankle Angles. Interestingly, Oestrogen was positively correlated with CMJ Hip Angular Velocity in the Concentric phase and in the SJ EMG of both muscles. It is important to notice that the SJ does not have the Eccentric phase, therefore, levels of Oestrogen appear to increase muscle activity in the Concentric Phase, results that was not expected due to the loosening effect expected to be caused by high levels of Oestrogen. Corroborating these findings, in the Eccentric phase, Oestrogen was negatively correlated with the SJ Ankle Angular Velocity. Given this result it is possible that differential Oestrogen and Progesterone responses might vary depending on the muscle group.

7.6 Conclusion

Asymmetries in flexibility in dancers did not affect the kinematics of the CMJ and SJ vertical jumps. Additionally, the intervention did not cause differences in the SJ angles whilst for the CMJ it affected both Control and Training limbs. Furthermore, the intervention decreased the asymmetry between limbs for the CMJ but not for the SJ. Interestingly, adjustments in the Control limb may happen, even when the limb did not undergo to direct training. However, given that Control and Training conditions are limbs of the same individual, the Central Nervous System may have played a role in these adjustments. The contradiction is

the correlation between Oestrogen and Progesterone with the dependent variables highlights the possibility that differential Oestrogen and Progesterone responses might vary depending on the muscle group.

Chapter 5: Any effect of Menstrual Cycle Phase (peak vs trough oestrogen) on the modulation of flexibility by muscle structure and function in dancers

“Educação é o que sobra quando se esquece o que foi aprendido na escola.”

Albert Einstein

“Education is what remains after one has forgotten what one has learned in school.”

Albert Einsten

8.1 Introduction

Oestrogen and progesterone are female hormones that fluctuate across the menstrual cycle phases (MCP) (Strauss and Barbieri, 2013). Their primary action is related to the maturation and implantation of the ovum; however, their variation causes many physiological effects, including changes in the thermoregulatory, respiratory, renal system and behavioural responses, such as stress response, neurotransmission, mood, pain modulation and drug metabolism (Becker and Hu, 2008). These secondary effects of oestrogen and progesterone and their interaction may in turn influence exercise performance (Xanne and De Jonge, 2003).

The potential effect of the hormone fluctuations during the MCP on exercise performance is most likely to be found during phases with comparatively significantly different hormone levels (Xanne and De Jonge, 2003), such as ovulation, follicular and luteal phases. Given that previous research found Oestrogen receptors in the human anterior cruciate ligament (Sciore et al., 1998), and that women who are chronically exposed to high levels of oestrogen (i.e. contraceptive pills), may have altered collagen content of tendon and ligaments (Hansen et al., 2013), Park et al. (2009a) tested the hypothesis that the knee laxity increases from the follicular phase to the ovulation due to effect of high oestradiol on the ligament during ovulation and decreases from ovulation to the luteal phase because of high progesterone levels. They found, in average, greater knee laxity during ovulation compared to luteal phase, however, the result varied among participants. Although some studies found greater joint laxity in the ovulatory phase compared to the other phases (Deie et al., 2002, Heitz et al., 1999, Park et al., 2009b), other studies contradicted this finding (Belanger et al., 2004, Eiling et al., 2007).

The inconclusive results on this matter might be related to the range of methods attempting to measure the hormonal concentration and its influence on the body, not least owing to differences in the timing of the measurement relative to the menstrual cycle phase. Besides possible changes in the laxity of the anterior cruciate ligament provided by oestradiol concentration, Eiling et al. (2007) found considerable effects on the muscle stiffness across the 28-day cycle. This stiffness modification is expected to cause a difference in strength and jump height performance.

The perception of pain has also been reported to alter during the MCP; oestrogen may influence the sensory processes. A significantly higher pain rate in the menstrual and premenstrual phases than in the mid-menstrual and ovulatory phases has been found (Tommaso, 2011). The modulation of pain plays a role in flexibility training since stretch tolerance affects the performance and the amount of load tolerated during the physical procedure of stretching (Chagas et al., 2008). Although studies evaluated, independently, variables that may affect flexibility performance, such as ROM, tendon laxity, pain tolerance and stiffness, no studies were found examining the flexibility modification in a multi-factorial approach across the MCP, especially in terms of the modulation of this capability by muscle structure and function. Understanding of any multiway interaction between these parameters is especially important for populations for whom flexibility is a crucial capability, such as for dance. In addition, in line with results of Chapter 4 that suggested asymmetries in flexibility between legs, the necessity to evaluate the influence of the MCP in both limbs was raised. Therefore, the aim of this chapter was to evaluate the effect of Menstrual Cycle Phases in dancers in terms of the modulation of flexibility by muscle structure and function in both legs (dominant vs non-dominant) separately.

8.2 Methods

8.2.1 Participants

Eleven female participants (mean [SD]: age 23.5 [2.94] years, body mass 67.65 [15.62] kg, height 1.63 [0.05] m) comprised the study. Participants were undergraduate contemporary dance students with average 10.5 [1.73] hours of dance practice and 6.12 [2.36] hours of other physical activity practice per week. Ethics, inclusion and exclusion criteria are described in the Overall Methods⁵⁰.

8.2.2 Procedures

A paper-based menstrual cycle calendar and a digital basal thermometer (Geratherm, Geratherm Medical, Geschwenda, Germany) were given to participants three months before the tests. They were required to measure their basal temperature every day just after waking up and to note down the precise hour and the temperature in C° within two decimal

⁵⁰ Vide Overall Methods section 3.1 and 3.2 page 53

places. Participants were also asked to highlight, the menstruation phase in the same calendar. In addition, an ovulation kit⁵¹ was also given to participants to be used from five days before the predicted ovulation to confirm the said ovulation. Thus, the duration and behaviour of each individual menstrual cycle were tracked aiming to increase the chances of carrying out the laboratory-based measures exactly during the targeted phases (see below in Figure 52).

Participants were tested on four separate sessions: the first one being the familiarisation, booked at each participant's first convenience, and the following three test sessions booked according to specific phases of the menstrual cycle (allowing a two-day window: follicular, ovulatory or luteal. The first phase was randomly set to any one of the phases until all phases were completed. Figure 52 shows the phases calculated in a 28-day menstrual cycle.

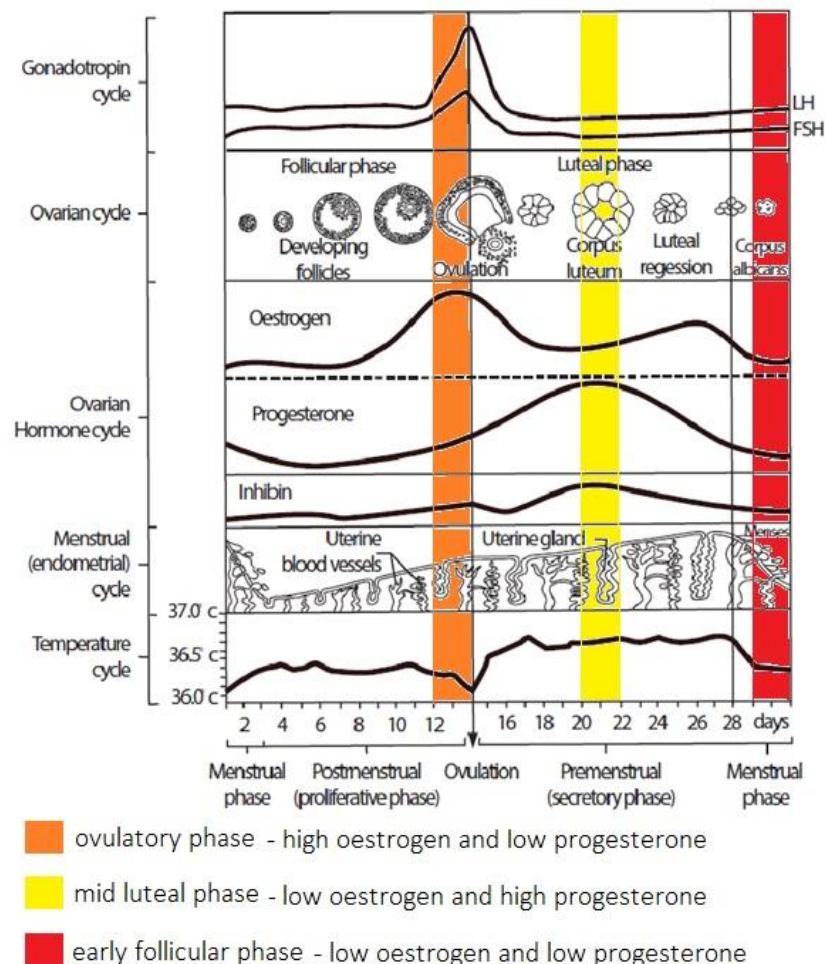

Figure 52: Illustration of the two-day window for each phase of the menstrual cycle in a regular 28-day cycle length.

⁵¹ Vide Overall Methods section 3.3.1 page 58

In each test session, participants attended the Phlebotomy Laboratory at Manchester Metropolitan University in the morning after an overnight fast over 12 hours. They were asked to drink 500 ml of water just after waking up (approximately two hours before the data collection) to guarantee the hydration level (according to the ACSM recommendations) for the blood⁵² sample collection. Following the phlebotomy procedures, participants had breakfast consisting of fruit tea, water, two slices of wholegrain bread with butter or jam, yoghurt and fruit (approximately 250 kcal). Anthropometry⁵³ measurements were performed, then, participant laid supine on a physiotherapy bed for the ultrasound recordings of the semitendinosus (ST)⁵⁴.

Following the ultrasound, participant stood on force platforms, each foot on a separate force plate, to perform the jump Pre-test consisting of three maximal CMJ, immediately followed by three maximal SJ. No warm-up before the jumps were performed. Then, participants were positioned on the Flexibility Equipment Test and performed the flexibility⁵⁵ test, which consisted of six trials aiming to reach the maximum ROM tolerated by the participant (ROM_{Max}).

Finally, participants undertook the pain mixed-method assessment. They were randomly assigned to perform the IWT⁵⁶ followed by the Questionnaires⁵⁷, or the Questionnaires followed by the IWT to avoid any order effect. Figure 53 illustrates the laboratory sessions and Figure 54 the order of tests.

⁵² Vide Overall Methods section 3.3.2 page 59

⁵³ Vide Overall Methods section 3.3.12 page 78

⁵⁴ Vide Overall Methods section 3.3.4 page 63

⁵⁵ Vide Overall Methods section 3.3.5 page 66

⁵⁶ Vide Overall Methods section 3.3.9 page 76

⁵⁷ Vide Overall Methods section 3.3.11 page 77

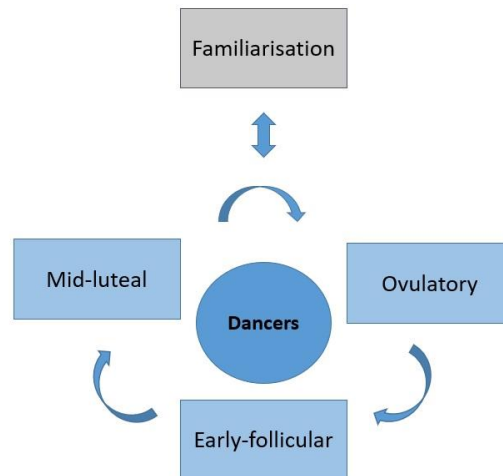

Figure 53: Illustrative figure of the familiarisation and test sessions.

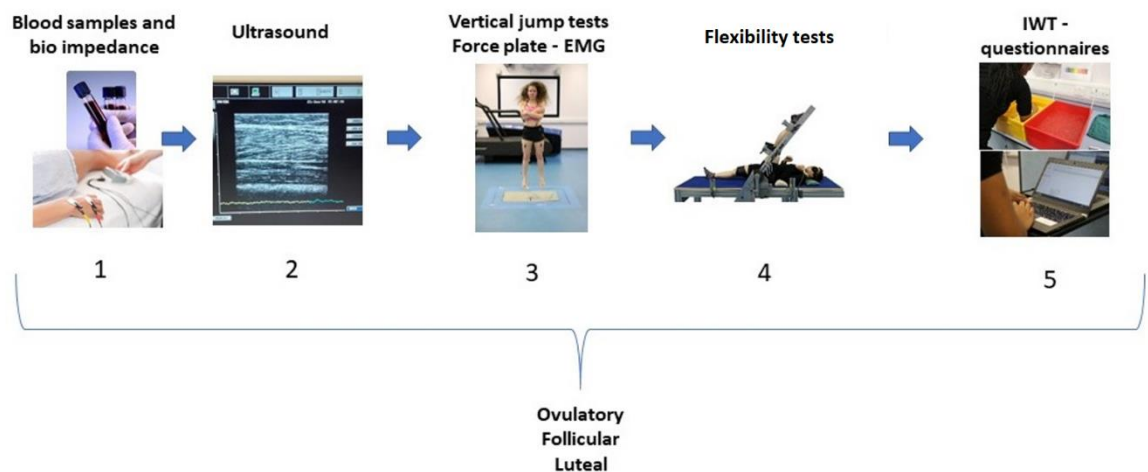

Figure 54: Illustrative figure of the tests' order. (Photos: Bárbara Pessali-Marques).

8.2.3 Outcome variables

Table 55, below, summarises the assessed variables in the current chapter⁵⁸.

Table 55: Outcome variables

Flexibility	Vertical Jump	Pain mix method	EMG	Ultrasound	Hormone and whole blood
ROM _{Max} Torque _{Max} FSS _{ROM} FSS _{torque} S _{MTU}	Jump height Impulse Force _{peak} V _{take-off}	SEFIP PASS VAS Ice Water Test	EMG _{ST} EMG _{RF} during CMJ and SJ	CSA Length Width Fat thickness Lean thickness Semitendinosus thickness	Oestrogen Progesterone Relaxin (serum) Cholesterol Lactate Glucose Triglycerides

ROM: Range of motion, Max: Maximal, FSS: first sensation of stretch, S: stiffness, MTU: muscle-tendon unit, V: velocity, SEFIP: Self-Estimated Functional Inability because of Pain, PASS: Pain Anxiety Symptom Scale, VAS: visual analogue scale, EMG: electromyography, RF: rectus femoris, ST: semitendinosus, CMJ: countermovement jump, SJ: squat jump, CSA: cross-sectional area.

⁵⁸ For complete description of variables vide Overall Methods Table 8 pages 56-58

8.3 Statistical Analyses

SPSS Statistics (v24 International Business Machines Corporation, New York, USA) was used for statistical analyses. Levene and Shapiro-Wilk statistic tests were performed to test the homogeneity of variance and the normality of the data, respectively. The comparison between flexible (dominant limb – D) vs. least flexible (non-dominant limb - nD) lower limb (hereafter referred to leg dominance) for all the dependent variables across the menstrual cycle phases (Ovulatory, Follicular and Luteal) for all dependent variables was performed using the ANOVA repeated measures six factors (when parametric) and the Friedman test (when non-parametric). Post hoc and Wilcoxon comparisons were performed to highlight which pairs were the basis for the main effect highlighted. A second analysis using the ANOVA repeated measures 3 factors was also performed to compare the relative change (i.e. delta) between the Pre- and Post-tests ($[DIF_{Post-Pre}]/pre$) for each variable between the phases (when parametric) and Friedman (when non-parametric). Finally, co-variance analyses (ANCOVA) were performed to evaluate the hormonal influence on the dependent variables and hence correct for any covariates where appropriate. The statistical significance adopted was $\alpha \leq 0.05$, study power at $\beta \geq 0.8$ (and effect size $p\epsilon^2 \geq 0.2$ where study power was adequate).

8.4 Results

8.4.1 Parametricity checks

Descriptive statistics of the DCN across the menstrual cycle phases is shown in Table 55 below. All variables presented significance level > 0.05 for the homogeneity tests but FSS_{torque} ($p = 0.037$) and peak force ($p = 0.018$) for the CMJ in the non-dominant limb, total peak force ($p = 0.005$) for the SJ, upper back ($p = 0.015$), back thighs ($p = 0.036$), shoulders (0.001) and ankles/feet ($p = 0.004$) from the SEFIP questionnaire presented significance level ($P > 0.05$) for the homogeneity test. Tables 56, 57, 58 and 59 present the non-normally distributed data⁵⁹.

Table 56: Descriptive analysis of the DCN across the menstrual cycle phases (average \pm standard deviation).

	Follicular	Ovulatory	Luteal

⁵⁹ Full normality results are presented in the Appendix L page 315.

Age (years)	23.5 ± 2.94	23.5 ± 2.94	23.5 ± 2.94
Height (m)	1.63 ± 0.05	1.63 ± 0.05	1.63 ± 0.05
Body mass (kg)	67.51 ± 15.97	67.6 ± 15.6	67.82 ± 16.00
Fat %	25.35 ± 4.53	30.3 ± 6.8	30.81 ± 6.03
Fat (kg)	21.36 ± 10.73	21.3 ± 10.6	29.53 ± 9.92
Lean %	69.50 ± 6.94	69.7 ± 6.8	69.18 ± 6.03
Lean (kg)	46.14 ± 6.24	46.4 ± 5.8	46.29 ± 6.92
Water %	48.39 ± 5.46	48.2 ± 5.7	48.08 ± 4.58
Water (L)	32.10 ± 4.33	32.2 ± 4.2	32.20 ± 4.30
Basal metabolism (j)	6487.20 ± 636.34	6460.7 ± 588.1	6449.00 ± 696.53
Body mass index	25.29 ± 4.62	25.4 ± 4.5	25.35 ± 4.53
Cholesterol (mmol/L)	4.80 ± 1.00	5.34 ± 1.53	4.72 ± 1.99
Triglycerids (mmol/L)	1.86 ± 1.45	1.75 ± 1.24	1.06 ± 0.24
Glucose (mmol/L)	5.80 ± 2.97	6.06 ± 3.61	5.04 ± 1.16
Lactate (mmol/L)	2.41 ± 2.22	1.52 ± 0.75	2.15 ± 2.29
Calf dominant limb (cm)	36.72 ± 4.06	37.11 ± 6.40	36.22 ± 7.84
Calf non-dominant limb (cm)	36.86 ± 3.67	37.11 ± .39	36.05 ± 7.84
Thigh dominant (cm)	53.31 ± 3.30	51.72 ± 6.40	51.31 ± 6.17
Thigh non-dominant (cm)	53.37 ± 3.75	51.54 ± 6.61	51.31 ± 5.96
Hips (cm)	98.22 ± 10.55	98.77 ± 10.14	100.86 ± 6.07
Waist (cm)	79.68 ± 16.86	78.77 ± 16.56	77.45 ± 15.30

Table 57: Non-parametric data. Shapiro-Wilk results. Data presented are *P* statistics.

Variable	Limb	Ovulatory	Follicular	Luteal
FSS _{torque}	Non-Dominant	n.s.	0.007	n.s.
	Dominant	n.s.	0.001	0.028
S _{MTU}	Dominant	n.s.	0.018	n.s.
Energy	Non-Dominant	n.s.	0.019	n.s.
	Dominant	n.s.	0.007	n.s.
Calf Circumference	Non-Dominant	0.002	n.s.	n.s.
	Dominant	0.002	n.s.	0.042
Thigh Circumference	Non-Dominant	0.033	n.s.	0.003
	Dominant	0.041	n.s.	0.013
Waist Circumference	n.a.	0.001	0.001	0.001
Body mass	n.a.	0.001	0.001	0.001
Height	n.a.	0.001	n.s.	0.001
Basal Metabolism	n.a.	0.009	0.026	0.008
BMI	n.a.	0.001	0.001	0.001
Mode PASS	n.a.	0.026	0.005	0.026
IWT	n.a.	0.005	0.005	0.008
PASS Cog Anx	n.a.	0.044	n.s.	n.s.
PASS Fear	n.a.	n.s.	0.025	n.s.
Cholesterol	n.a.	n.s.	0.098	n.s.
Lactate	n.a.	0.001	n.s.	n.s.
Length	Non-Dominant	n.s.	0.020	n.s.
	Dominant	0.011	0.020	n.s.
CSA	Non-Dominant	0.019	0.001	n.s.
ST thickness	Non-Dominant	n.s.	0.039	n.s.
Total impulse CMJ	Both	n.s.	0.014	0.059
Force _{peak} SJ	Dominant	0.047	n.s.	n.s.
Total impulse SJ	Both	0.039	n.s.	0.099
Total force _{peak} SJ	Both	n.s.	0.014	n.s.
EMG _{ST} CMJ	Non-Dominant	0.040	n.s.	n.s.
EMG _{ST} SJ	Dominant	0.022	n.s.	n.s.
Oestrogen	n.a.	n.s.	n.s.	0.049

Progesterone	n.a.	0.033	n.s.	0.014
Relaxin	n.a.	0.018	0.001	0.002

P: level of significance obtained, CMJ: countermovement jump, SJ: Squat jump, ST: semitendinosus, CSA: Cross-sectional area, BMI: Body mass index, FSS: first sensation of stretch, Cog Anx: Cognitive anxiety, IWT: Ice water test, S_{MTU} : muscle-tendon unit stiffness, EMG: Electromyography, V: velocity, Max: Maximal, n.a.: not applicable, n.s.: not statistically significant.

Table 58: Non-parametric data $\Delta [(D-nD)/D]$ variables. Shapiro-Wilk results. Data presented are *P* statistics.

Variable	Follicular	Ovulatory	Luteal
ΔROM_{Max}	0.019	n.s.	n.s.
$\Delta Torque_{Max}$	n.s.	0.028	n.s.
ΔFSS_{torque}	0.049	n.s.	n.s.
$\Delta Energy$	0.012	n.s.	n.s.
$\Delta CMJ Impulse$	0.001	0.027	n.s.
$\Delta CMJ force_{peak}$	0.029	n.s.	n.s.
$\Delta SJ Impulse$	0.001	0.001	0.001
$\Delta Length$	0.001	0.001	0.001
$\Delta ST thickness$	n.s.	n.s.	0.024
$\Delta Total Lean thickness$	n.s.	0.032	n.s.

P: level of significance obtained, ROM: a range of motion, Max: maximal, CMJ: countermovement jump, SJ: Squat jump, ST: semitendinosus, FSS: first sensation of stretch, n.s.: not statistically significant.

Table 59: Non-parametric data ration hormones concentration at Luteal and Ovulatory by Follicular phase. Shapiro-Wilk results. Data presented are *P* statistics.

	Luteal/Follicular	Ovulatory/Follicular
Oestrogen	0.009	0.027
Progesterone	0.002	0.017
Relaxin	0.001	n.s.
Length	0.001	0.007
Width	0.007	n.s.
ST thickness	0.007	n.s.
Total Lean thickness	0.001	n.s.
Force_{peak} CMJ	0.001	0.001
Total impulse CMJ	n.s.	0.001
Force_{peak} SJ	0.003	0.001
EMG_{RF} CMJ	0.048	n.s.
EMG_{ST} CMJ	n.s.	0.001
EMG_{RF} SJ	0.029	0.009
EMG_{ST} SJ	0.033	n.s.
FSS_{ROM}	0.017	n.s.
FSS_{torque}	0.016	0.003
SMTU	n.s.	0.040

P: level of significance obtained, CMJ: countermovement jump, SJ: Squat jump, ST: semitendinosus, RF: Rectus femoris, ROM: range of motion, S_{MTU} : Muscle tendon-unit stiffness, FSS: first sensation of stretch, n.s.: not statistically significant.

8.4.2 Hormonal variation across menstrual cycle phases

Table 60 and Figure 55 show the hormonal concentration variation across the menstrual cycle phases. Despite the trends for oestrogen to be greatest at the ovulatory phase, no differences among the phases were found for Oestrogen, Progesterone and Relaxin.

Table 60: ANOVA repeated measures three factors when parametric with pairwise comparisons when necessary and Friedman when non-parametric data with Wilcoxon when necessary (phase comparisons).

Hormone	<i>P</i>
Oestrogen	0.710
Progesterone	0.358
Relaxin	0.181

P: significance level. Grey cells: Non-parametric correlation with Wilcoxon when necessary. White cells: Parametric correlation with pairwise comparisons when necessary. Bolt numbers: Statistical significance. Light numbers: not statistically significant.

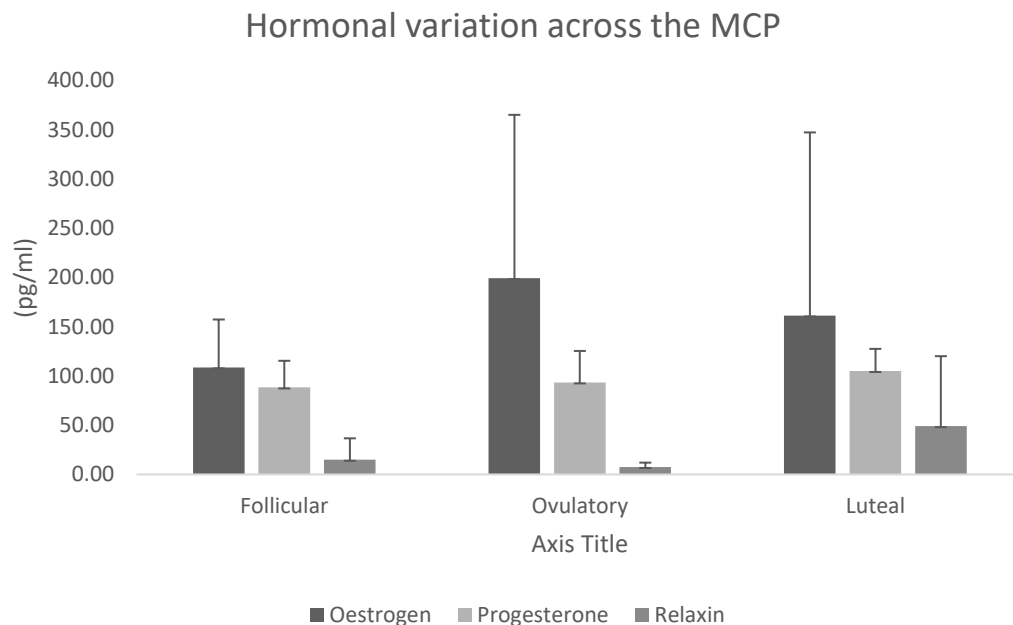

Figure 55: Average and standard deviation of Oestrogen, Progesterone and Relaxin at Follicular, Ovulatory and Luteal phases of the menstrual cycle.

8.4.3 Structural and functional characteristics across the menstrual cycle: phases and limb comparisons

ANOVA repeated measures (when parametric) and Friedman (when non-parametric) with pairwise and Wilcoxon comparisons respectively, when necessary, results are presented in the table below (Table 61).⁶⁰ Only three from 53 dependent variables analysed showed a significant difference when structural and functional characteristics were compared either between dominant and non-dominant limbs or among the phases. From those statistically different, one variable only showed a difference between limbs, while the others differed across the menstrual cycle phases (see below).

⁶⁰ Full table with correlations is presented in the Appendix M page 319

Table 61: ANOVA repeated measures six factors (Dominant and non-dominant limb at Follicular, Ovulatory and Luteal Phases) and three factors (either limb comparisons in each phase or phase comparisons). Data presented are *P* statistics.

Variables	Phases	Phases comparison for each limb					Dominant vs non-dominant limb comparisons in each phase			Phase comparisons			Main effect	
		Dominant limb			Non-dominant limb			Follicular	Ovulatory	Luteal	Follicular vs Ovulatory	Follicular vs Luteal		Ovulatory vs Luteal
		Follicular vs Ovulatory	Follicular vs Luteal	Ovulatory vs Luteal	Follicular vs Ovulatory	Follicular vs Luteal	Ovulatory vs Luteal							
ROM _{Max}		0.989	0.655	0.547	0.497	0.088	0.379	0.004	0.001	0.001	n.a.	n.a.	n.a.	<i>F</i>_{4,157} <i>P</i>=0.019; $\eta^2_p=0.294$; $\beta=0.759$
Torque _{Max}		-	-	-	-	-	-	-	-	-	n.a.	n.a.	n.a.	<i>F</i> _{1,093} <i>P</i> =0.362; $\eta^2_p=0.098$; $\beta=0.237$
FSS _{ROM}		-	-	-	-	-	-	-	-	-	n.a.	n.a.	n.a.	<i>F</i> _{1,495} <i>P</i> =0.241; $\eta^2_p=0.130$; $\beta=0.401$
FSS _{torque}		-	-	-	-	-	-	-	-	-	n.a.	n.a.	n.a.	0.201
S _{Mtu}		-	-	-	-	-	-	-	-	-	n.a.	n.a.	n.a.	0.936
Energy		-	-	-	-	-	-	-	-	-	n.a.	n.a.	n.a.	0.486
Calf Circumference		-	-	-	-	-	-	-	-	-	n.a.	n.a.	n.a.	0.115
Thigh Circum		-	-	-	-	-	-	-	-	-	n.a.	n.a.	n.a.	0.906
Hips Circum		n.a.	n.a.	n.a.	n.a.	n.a.	n.a.	n.a.	n.a.	n.a.	-	-	-	<i>F</i> _{0,441} <i>P</i> =0.650; $\eta^2_p=0.042$; $\beta=0.112$
Waist Circum		n.a.	n.a.	n.a.	n.a.	n.a.	n.a.	n.a.	n.a.	n.a.	-	-	-	0.637
Body mass		n.a.	n.a.	n.a.	n.a.	n.a.	n.a.	n.a.	n.a.	n.a.	-	-	-	0.574
Height		n.a.	n.a.	n.a.	n.a.	n.a.	n.a.	n.a.	n.a.	n.a.	-	-	-	0.532
Body Fat		n.a.	n.a.	n.a.	n.a.	n.a.	n.a.	n.a.	n.a.	n.a.	-	-	-	<i>F</i> _{0,584} <i>P</i> =0.567; $\eta^2_p=0.055$; $\beta=0.133$
Body Lean		n.a.	n.a.	n.a.	n.a.	n.a.	n.a.	n.a.	n.a.	n.a.	-	-	-	<i>F</i> _{0,584} <i>P</i> =0.567; $\eta^2_p=0.055$; $\beta=0.133$
Water		n.a.	n.a.	n.a.	n.a.	n.a.	n.a.	n.a.	n.a.	n.a.	-	-	-	<i>F</i> _{0,530} <i>P</i> =0.597; $\eta^2_p=0.050$; $\beta=0.125$
Basal Metabolism		n.a.	n.a.	n.a.	n.a.	n.a.	n.a.	n.a.	n.a.	n.a.	-	-	-	0.806
BMI		n.a.	n.a.	n.a.	n.a.	n.a.	n.a.	n.a.	n.a.	n.a.	-	-	-	0.822
IWT		n.a.	n.a.	n.a.	n.a.	n.a.	n.a.	n.a.	n.a.	n.a.	-	-	-	0.653
Total PASS		n.a.	n.a.	n.a.	n.a.	n.a.	n.a.	n.a.	n.a.	n.a.	0.060	0.416	0.009	<i>F</i>_{3,515} <i>P</i>=0.049; $\eta^2_p=0.260$; $\beta=0.587$
Mode PASS		n.a.	n.a.	n.a.	n.a.	n.a.	n.a.	n.a.	n.a.	n.a.	-	-	-	0.765
PASS Cog Anx		n.a.	n.a.	n.a.	n.a.	n.a.	n.a.	n.a.	n.a.	n.a.	-	-	-	0.994
PASS Esc		n.a.	n.a.	n.a.	n.a.	n.a.	n.a.	n.a.	n.a.	n.a.	-	-	-	<i>F</i> _{2,699} <i>P</i> =0.121; $\eta^2_p=0.213$; $\beta=0.358$
PASS Fear		n.a.	n.a.	n.a.	n.a.	n.a.	n.a.	n.a.	n.a.	n.a.	-	-	-	0.175
PASS Physio		n.a.	n.a.	n.a.	n.a.	n.a.	n.a.	n.a.	n.a.	n.a.	0.001	0.250	0.023	<i>F</i>_{7,219} <i>P</i>=0.009; $\eta^2_p=0.419$; $\beta=0.824$
Cholesterol		n.a.	n.a.	n.a.	n.a.	n.a.	n.a.	n.a.	n.a.	n.a.	-	-	-	0.222
Triglycerides		n.a.	n.a.	n.a.	n.a.	n.a.	n.a.	n.a.	n.a.	n.a.	-	-	-	<i>F</i> _{0,459} <i>P</i> =0.662; $\eta^2_p=0.187$; $\beta=0.087$
Glucose		n.a.	n.a.	n.a.	n.a.	n.a.	n.a.	n.a.	n.a.	n.a.	-	-	-	<i>F</i> _{0,683} <i>P</i> =0.560; $\eta^2_p=0.406$; $\beta=0.066$
Lactate		n.a.	n.a.	n.a.	n.a.	n.a.	n.a.	n.a.	n.a.	n.a.	-	-	-	0.222
Length		-	-	-	-	-	-	-	-	-	n.a.	n.a.	n.a.	0.293
Width		-	-	-	-	-	-	-	-	-	n.a.	n.a.	n.a.	0.804
CSA		-	-	-	-	-	-	-	-	-	n.a.	n.a.	n.a.	0.612
Fat thickness		-	-	-	-	-	-	-	-	-	n.a.	n.a.	n.a.	<i>F</i> _{0,467} <i>P</i> =0.558; $\eta^2_p=0.085$; $\beta=0.092$
ST thickness		-	-	-	-	-	-	-	-	-	n.a.	n.a.	n.a.	0.217
Lean thickness		-	-	-	-	-	-	-	-	-	n.a.	n.a.	n.a.	<i>F</i> _{0,682} <i>P</i> =0.641; $\eta^2_p=0.120$; $\beta=0.207$

Impulse CMJ	-	-	-	-	-	-	-	-	-	-	n.a.	n.a.	n.a.	<i>F</i> _{1.062} <i>P</i> =0.362; η^2_{ρ} =0.096; β =0.203
Force_{peak} CMJ	-	-	-	-	-	-	-	-	-	-	n.a.	n.a.	n.a.	<i>0.458</i>
V_{take-off} CMJ	n.a.	n.a.	n.a.	n.a.	n.a.	n.a.	n.a.	n.a.	n.a.	n.a.	-	-	-	<i>F</i> _{1.073} <i>P</i> =0.361; η^2_{ρ} =0.097; β =0.211
Jump height CMJ	n.a.	n.a.	n.a.	n.a.	n.a.	n.a.	n.a.	n.a.	n.a.	n.a.	-	-	-	<i>F</i> _{1.091} <i>P</i> =0.355; η^2_{ρ} =0.098; β =0.214
Total impulse CMJ	n.a.	n.a.	n.a.	n.a.	n.a.	n.a.	n.a.	n.a.	n.a.	n.a.	-	-	-	<i>0.844</i>
Total force_{peak} CMJ	n.a.	n.a.	n.a.	n.a.	n.a.	n.a.	n.a.	n.a.	n.a.	n.a.	-	-	-	<i>0.844</i>
Impulse SJ	-	-	-	-	-	-	-	-	-	-	n.a.	n.a.	n.a.	<i>F</i> _{0.498} <i>P</i> =0.633; η^2_{ρ} =0.047; β =0.124
Force_{peak} SJ	-	-	-	-	-	-	-	-	-	-	n.a.	n.a.	n.a.	<i>F</i> _{1.013} <i>P</i> =0.420; η^2_{ρ} =0.092; β =0.331
V_{take-off} SJ	n.a.	n.a.	n.a.	n.a.	n.a.	n.a.	n.a.	n.a.	n.a.	n.a.	-	-	-	<i>F</i> _{2.707} <i>P</i> =0.091; η^2_{ρ} =0.213; β =0.474
Jump height SJ	n.a.	n.a.	n.a.	n.a.	n.a.	n.a.	n.a.	n.a.	n.a.	n.a.	-	-	-	<i>F</i> _{2.610} <i>P</i> =0.098; η^2_{ρ} =0.207; β =0.460
Total impulse SJ	n.a.	n.a.	n.a.	n.a.	n.a.	n.a.	n.a.	n.a.	n.a.	n.a.	-	-	-	<i>0.351</i>
Total force_{peak} SJ	n.a.	n.a.	n.a.	n.a.	n.a.	n.a.	n.a.	n.a.	n.a.	n.a.	-	-	-	<i>0.732</i>
EMG_{RF} CMJ	-	-	-	-	-	-	-	-	-	-	n.a.	n.a.	n.a.	<i>F</i> _{0.379} <i>P</i> =0.635; η^2_{ρ} =0.159; β =0.071
EMG_{ST} CMJ	-	-	-	-	-	-	-	-	-	-	n.a.	n.a.	n.a.	<i>F</i> _{1.024} <i>P</i> =0.438; η^2_{ρ} =0.255; β =0.128
EMG_{RF} SJ	-	-	-	-	-	-	-	-	-	-	n.a.	n.a.	n.a.	<i>F</i> _{0.883} <i>P</i> =0.473; η^2_{ρ} =0.227; β =0.155
EMG_{ST} SJ	-	-	-	-	-	-	-	-	-	-	n.a.	n.a.	n.a.	<i>0.534</i>

P: level of significance obtained, CMJ: countermovement jump, SJ: Squat jump, ST: semitendinosus, RF: rectus femoris, v: velocity, CSA: Cross-sectional area, BMI: Body mass index, ROM: range of motion, Max: maximal FSS: first sensation of stretch, Cog Anx: Cognitive anxiety, IWT: Ice water test, *S*_{MTU}: muscle-tendon unit stiffness, EMG: Electromyography, V: velocity, circum: Circumference, n.a.: not applicable, SEFIP: Self-Estimated Functional Inability because of Pain, PASS: Pain Anxiety Symptom Scale, Cog Anx: cognitive anxiety, Esc: escape. Grey cells: Nonparametric correlation with Wilcoxon when necessary. White cells: Parametric correlation with pairwise comparisons when necessary. Bolt numbers: Statistical significance. Light numbers: non-statistical significance. Italic variables: Asymptomatic significance. - : No main effect, therefore no further comparisons required.

A significant difference between the dominant and non-dominant limb was found for the ROM_{Max} at all the menstrual cycle phases, no significant difference, however, was found comparing the phases (Table 62 and Figure 56).

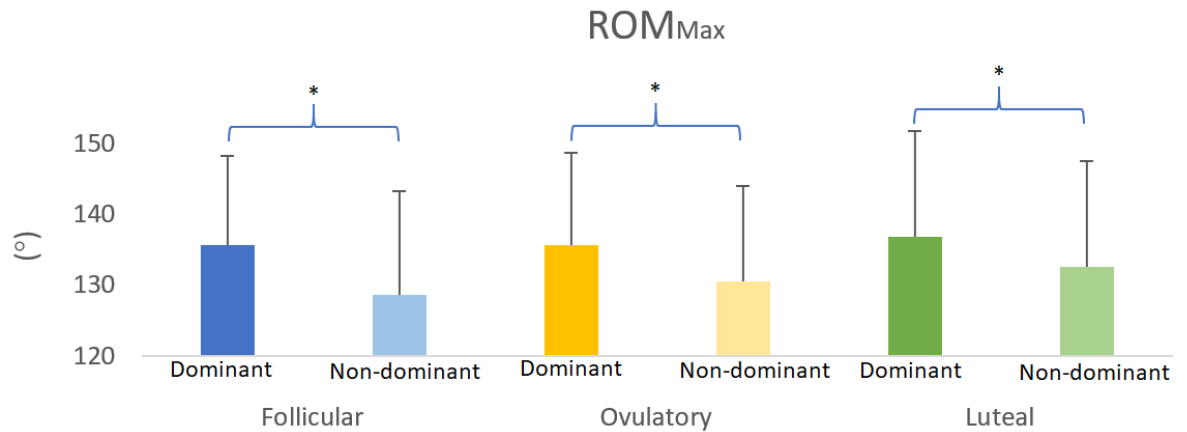

Figure 56: ROM_{Max} comparisons between limbs and menstrual cycle phases. *: Statistical significance between limbs.

Total PASS was found to be greater at Ovulatory when compared to Luteal phase. No differences, however, were found either between Luteal and Follicular or Ovulatory and Follicular (Table 62 and Figure 57).

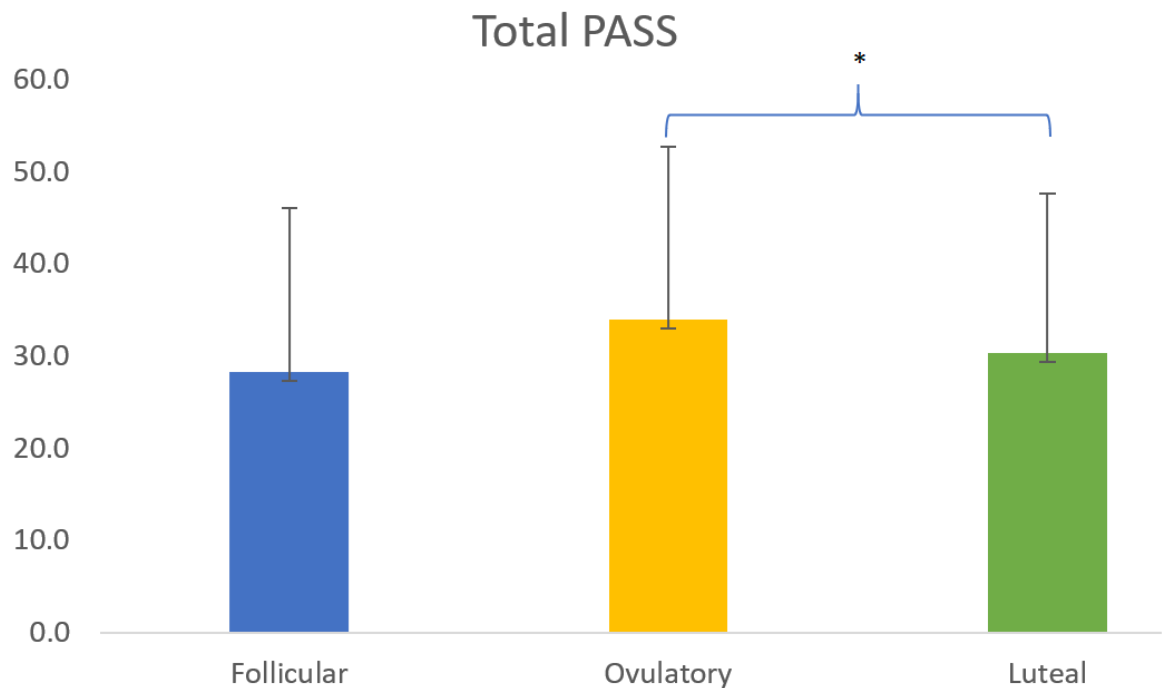

Figure 57: Total PASS across the menstrual cycle. *: Statistical significance between the phases.

The Physiological Anxiety subscale from the PASS questionnaires was found to be statistically significantly different when results from Ovulatory phase were compared to the Luteal and when results from the Ovulatory phase were compared to the Follicular phase. No difference was found between Follicular and Luteal phases (Table 60 and Figure 58).

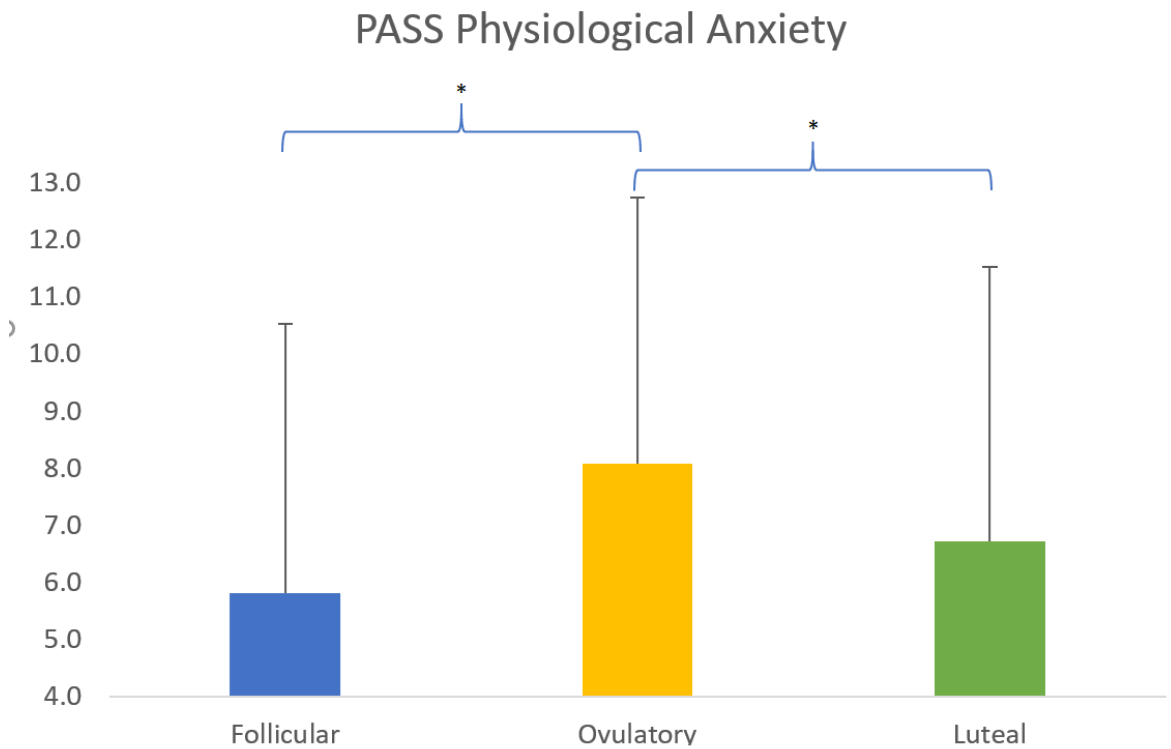

Figure 58: PASS Physiological Anxiety comparison across the menstrual cycle. *: Statistical significance between the phases.

8.4.4 Structural and functional characteristics across the menstrual cycle: delta $[(D - nD)/D]$ comparisons between the phases

A secondary analysis aiming to identify if any asymmetry level between limbs would vary across the menstrual cycle was performed. No differences in the relative limb differences (delta) were found between the phases (Table 62).

Table 62: ANOVA repeated measures three factors when parametric with pairwise comparisons when necessary and Friedman when non-parametric data with Wilcoxon when necessary (phase comparisons). Data presented are *P* statistics.

Phases	Phase comparisons			Main effect
	Follicular vs Ovulatory	Follicular vs Luteal	Ovulatory vs Luteal	
ΔROM_{Max}	-	-	-	0.219
$\Delta Torque_{Max}$	-	-	-	0.351

Δ FSS _{ROM}	-	-	-	$F_{0.777} P=0.473; \eta^2_p=0.072; \beta=0.164$
Δ FSS _{torque}	-	-	-	0.219
Δ S _{MTU}	-	-	-	$F_{0.728} P=0.495; \eta^2_p=0.068; \beta=0.138$
Δ Energy	-	-	-	0.976
Δ CMJ Impulse	-	-	-	0.629
Δ CMJ force _{peak}	-	-	-	0.256
Δ SJ Impulse	-	-	-	0.844
Δ SJ force _{peak}	-	-	-	$F_{0.796} P=0.465; \eta^2_p=0.074; \beta=0.167$
Δ Length	-	-	-	0.333
Δ Width	-	-	-	$F_{0.382} P=0.691; \eta^2_p=0.060; \beta=0.98$
Δ CSA	-	-	-	$F_{0.703} P=0.515; \eta^2_p=0.105; \beta=0.142$
Δ Fat thickness	-	-	-	0.570
Δ ST thickness	-	-	-	0.956
Δ Total Lean thickness	-	-	-	$F_{2.114} P=0.171; \eta^2_p=0.297; \beta=0.334$
Δ EMG _{RF} CMJ	-	-	-	$F_{0.211} P=0.818; \eta^2_p=0.096; \beta=0.067$
Δ EMG _{ST} CMJ	-	-	-	$F_{0.365} P=0.708; \eta^2_p=0.109; \beta=0.086$
Δ EMG _{RF} SJ	-	-	-	$F_{0.257} P=0.782; \eta^2_p=0.079; \beta=0.075$
Δ EMG _{ST} SJ	-	-	-	$F_{3.432} P=0.205; \eta^2_p=0.632; \beta=0.196$
Δ Calf Circum	-	-	-	$F_{3.023} P=0.071; \eta^2_p=0.232; \beta=0.520$
Δ Thigh Circum	-	-	-	$F_{0.297} P=0.746; \eta^2_p=0.029; \beta=0.091$

Δ : (D-nD)/D, P: level of significance obtained, CMJ: countermovement jump, SJ: Squat jump, ST: semitendinosus, RF: rectus femoris, CSA: Cross-sectional area, ROM: range of motion, Max: maximal FSS: first sensation of stretch, S_{MTU}: muscle-tendon unit stiffness, EMG: Electromyography, Circum: Circumference, Grey cells: Nonparametric correlation with Wilcoxon when necessary. White cells: Parametric correlation with pairwise comparisons when necessary. Bolt numbers: Statistical significance. Light numbers: non-statistical significance. - : No main effect, therefore no further comparisons required.

8.4.5 Correlations between change in outcome variables and change in hormone levels

To determine whether the variation of hormones across the menstrual cycle was a covariate in our analyses a series of bivariate correlations between outcome measures against the hormonal changes were carried out. Relative change in all dependent variables and relative change in hormone concentrations were correlated using values from the Follicular phase as a baseline. Table 63 shows only the significant⁶¹ correlations in these further data mining. It is thus remarkable that oestrogen change was associated with a change in 11 outcome variables, progesterone change was associated with a change in 7 outcome variables, and relaxin change was associated with a change in 15 outcome variables. Finally, Table 64 shows whether each hormones DELTA in luteal/follicular change was different from its change in ovulatory/follicular.

Table 63: Pearson (when parametric) and Spearman (when non-parametric) significant correlations. Data presented are *P* statistics.

		Oestrogen	Progesterone	Relaxin
Significant correlations Luteal/Follicular	Muscle length	$P = 0.008 r = -0.560^{**}$	$P = 0.022 r = 0.587^*$	n.s.
	Muscle CSA	$P = 0.044 r = -0.413^*$	n.s.	n.s.
	Fat thickness	$P = 0.022 r = -0.480^*$	$P = 0.044 r = 0.513^*$	$P = 0.007 r = 0.683^{**}$

⁶¹ See complete table Appendix L page 315

	Lean	n.s.	n.s.	$P = 0.015$ $r = 0.626^*$
	CMJ EMG_{RF}	$P = 0.010$ $r = -0.611^*$	n.s.	n.s.
	CMJ EMG_{ST}	$P = 0.001$ $r = -0.926^{**}$	$P = 0.006$ $r = 0.822^{**}$	n.s.
	SJ EMG_{RF}	n.s.	n.s.	$P = 0.017$ $r = 0.790^*$
	SJ EMG_{ST}	n.s.	n.s.	$P = 0.002$ $r = 0.911^{**}$
Significant correlations Ovulatory/Follicular	Muscle length	$P = 0.004$ $r = 0.599^{**}$	n.s.	$P = 0.049$ $r = 0.460^*$
	Muscle CSA	n.s.	n.s.	$P = 0.006$ $r = -0.646^{**}$
	Fat thickness	n.s.	n.s.	$P = 0.006$ $r = -0.647^{**}$
	ST thickness	$P = 0.001$ $r = 0.676^{**}$	$P = 0.010$ $r = -0.612^*$	$P = 0.001$ $r = -0.872^{**}$
	Lean	n.s.	$P = 0.045$ $r = -0.470^*$	$P = 0.001$ $r = -0.881^{**}$
	FSS_{torque}	$P = 0.020$ $r = 0.463^*$	n.s.	$P = 0.028$ $r = -0.485^*$
	S_{MTU}	n.s.	n.s.	$P = 0.001$ $r = -0.781^{**}$
	Energy	n.s.	$P = 0.034$ $r = -0.467^*$	$P = 0.021$ $r = -0.512^*$
	CMJ Force_{Peak}	n.s.	n.s.	$P = 0.022$ $r = -0.509^*$
	CMJ Total Force_{Peak}	$P = 0.040$ $r = -0.578^*$	n.s.	n.s.
	SJ Force_{Peak}	$P = 0.021$ $r = -0.459^*$	n.s.	n.s.
	CMJ EMG_{RF}	$P = 0.021$ $r = 0.549^*$	n.s.	n.s.
		SJ EMG_{RF}	n.s.	n.s.

P: level of significance obtained, *r*: correlation, *: Correlation is significant at the 0.05 level (1-tailed). **: Correlation is significant at the 0.01 level (1-tailed), n.s.: not significantly different, CMJ: countermovement jump, SJ: Squat jump, ST: semitendinosus, RF: rectus femoris, CSA: Cross-sectional area, ROM: range of motion, Max: maximal FSS: first sensation of stretch, S_{MTU}: muscle-tendon unit stiffness, EMG: Electromyography, , Grey cells: Spearman's correlation, White cells: Pearson's correlation.

Table 64: Wilcoxon analysis of the hormones in Luteal/Follicular and Ovulatory/Follicular.

	Oestrogen	Progesterone	Relaxin
Z	$P = -0.635$	-1.341	-2.812
Exact Sig. (1-tailed)	$P = 0.271$	$P = 0.097$	$P = 0.001$

P: level of significance obtained, Bolt numbers: Statistical significance. Light numbers: non-statistical significance.

8.5 Discussion

The aim of this chapter was to evaluate any effect of Menstrual Cycle Phases (MCP) in dancers in terms of the modulation of flexibility by muscle structure and function. It was hypothesised that in the ovulatory phase the MTU compliance would be increased and in the luteal, the compliance would be decreased due to the hormonal concentration variation of oestrogen, progesterone and/or relaxin in each phase. Thus, the structural and functional characteristics of the MTU were expected to be affected.

8.5.1 Raw data analyses

No statistical differences in the concentrations of the respective hormones were found between the ovulatory, luteal and follicular phases in the current research contradicting previous literature that found significantly higher levels of estradiol during the post-ovulatory and mid-luteal phases compared to the menses phase and levels of progesterone significantly lower during the menses and post-ovulatory phases compared to the mid-luteal

phase (Abt et al., 2007). The non-difference in the hormones across the phases of the menstrual cycle could be indicative of two effects: (a) either the large inter-individual variability in hormones drowned out any group pattern or (b) participants did not present regular menstrual cycle. This implication was somehow expected based on previous research showing irregularities in dancers' menstrual cycle (Frisch et al., 1980, Warren et al., 2002, Warren et al., 2003, Brooks-Gunn et al., 1987). In addition, the amount of exercise practised, and even emotional aspects, added to inter and intra-variability make it difficult to reach the targeted phase for assessments. Moreover, unless days are counted in retrospect, it is difficult to predict the day of ovulation (Xanne and De Jonge, 2003), therefore, any variation in one or more of these aspects might affect the accuracy in reaching the hormonal peak. Another difficult factor when comparing the results of the current study with previous literature is the range of different research methods, such as timing of testing and number of phases tested (Sarwar et al., 1996, Sherman and Korenman, 1975, Sherman et al., 1976, Van Goozen et al., 1997, Wojtys et al., 2002). The aforementioned points are relevant because possible effects of the menstrual cycle hormones on exercise performance are easily obscured and their potential effect is most likely to be found during those phases with significantly different hormone levels (Xanne and De Jonge, 2003).

Trying to reach the hormonal peak, participants were asked to fill a calendar with the hour and temperature daily after waking up for, preferentially, three months before the data collection and to use urine strips from 5 days before the predicted ovulation to highlight the correct ovulation day. Unfortunately, only a few participants filled the calendars. Most of them submitted uncompleted calendars or had no time to complete those before the data acquisition deadlines. Hence, their menstrual cycle phases were estimated for each participant according to available data.

Another important aspect is that most ovulating women have an increase in the body basal temperature of approximately 0.3 degrees after ovulation, which is sustained throughout the luteal phase (Marshall, 1963, Horvath and Drinkwater, 1982). In the current study, the increase in the temperature after ovulation was also detected and a variation averaged $1.60 \pm 0.16^\circ$ was found across the entire cycle. Bauman (1981) however, did not find an increase

in the basal body temperature during the luteal phase in some women, highlighting the variability and the individuality of each one of them (Bauman, 1981).

In a study analysing 30 years of data directed to the study of the temporal characteristics of the human menstrual cycle it was concluded that the 28-days the menstrual cycle in a woman is believed to be is unsupported, and in fact normally varies substantially (Treloar et al., 1967). Each woman has her own central trend and variation which changes with age. Variation, as opposed to regularity, is the rule in the menstrual cycle, even within (Treloar et al., 1967) the same woman; long cycles in young women of normal body weight, for example, were characterized by delayed follicular maturation and hormonal changes, but with normal ovulation. In addition, inconsistencies from one menstrual cycle to another do not necessarily reflect alterations in the bleeding pattern (Harlow and Ephross, 1995), and based on a regular cycle length (mean 26-days), participants with menstrual abnormalities could have been considered normal if hormonal analysis is not performed (Sherman and Korenman, 1974). Data obtained from participants who completely filled the calendars showed inconsistencies in the length of the menstrual cycles; Figure 61 shows the variation of menstrual cycle length using data from one participant which would be considered as having a regular menstrual cycle. Altogether, these factors may increase the difficulty to predict the ideal test sessions, being, therefore, one of the reasons for the lack of difference in the hormone concentration between the menstrual cycle phases in the current study.

In addition, the ovulation detected by the urine strips does not coincide with the peak in the basal body temperature also indicating ovulation. The ovulation kit aims to detect the urine increased level of LH just before the ovulation with 99% of accuracy. Previous studies have compared the validity of ovulation kits, including the one used in the current research, and found them to be correlated (between 68%–84%) to the gold methods to predict ovulation (Nielsen et al., 2001). The authors suggest that potential sources of variation include an improper performance of the test kits, differing kit sensitivities, individual test kit variation, variation in the amplitude and duration of LH surges, and variation in interpretation of the test window colour (Miller and Soules, 1996, Nielsen et al., 2001). In the present study, participants have used the kits at home following instructions given by the researchers,

however, researchers did not have further contact with the strips to double-check the results provided by participants.

Figure 59: Menstrual cycle length of one participant.

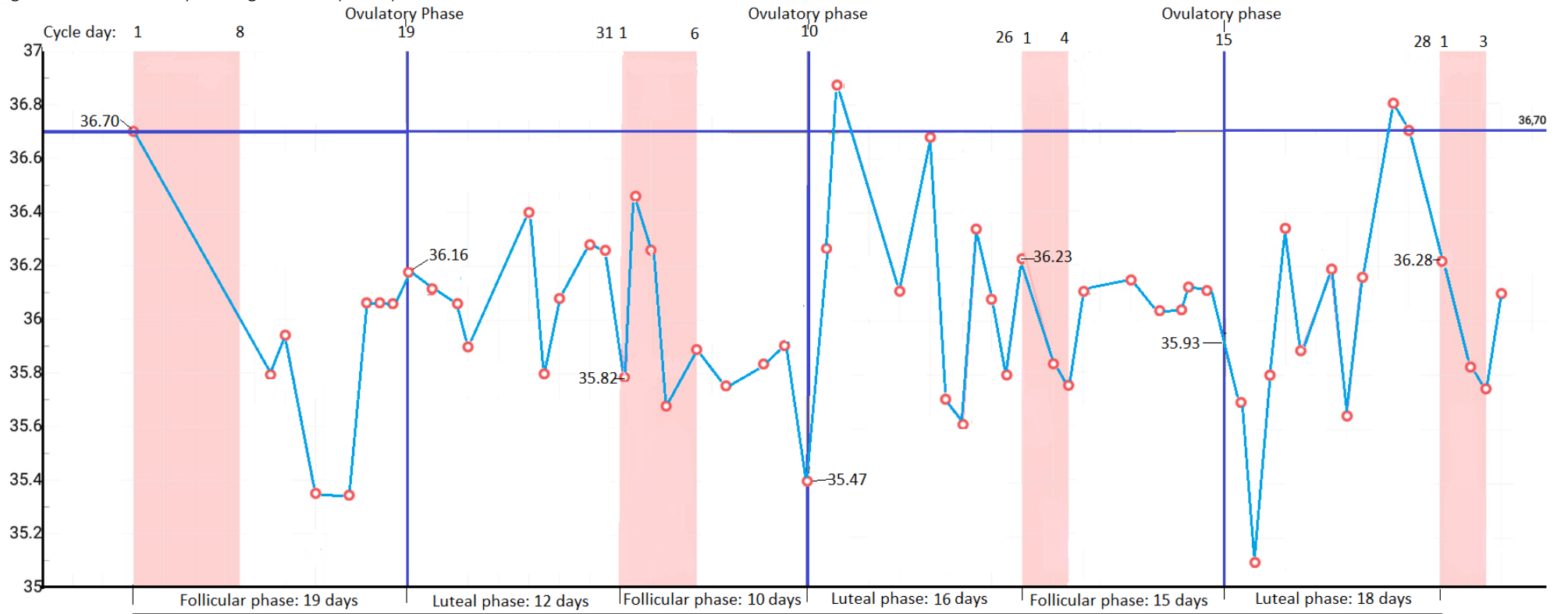

Given the multi-factorial effects caused by the variation of female hormones across the MCP and the range of different methods (and associated reliability and precision levels) attempting to measure the hormonal concentration and its influence on the body, studies results have been inconclusive. Regarding the structural characteristics of the muscle-tendon unit (MTU), no differences in the CSA, fat thickness, ST thickness, lean, width and length were found across the menstrual cycle phases in the current study. It is interesting to note that CSA has been shown to decline at the time of the menopause and postmenopausal women under hormone replacement therapy tend to be susceptible to a number of these steep deleterious changes (Phillips et al., 1996), suggesting that oestrogen may have a muscle-strengthening action (Phillips et al., 1996). Phillips et al. (1996) found muscle CSA to vary greatly between individuals. The CSA, however, was measured anthropometrically using callipers, while the CSA referred in the current study was acquired via ultrasound imaging. Despite the higher degree of precision with ultrasound imaging compared with anthropometry, no differences were found in the present study across the MCP. (Lebrun et al., 1995) also did not find differences in weight, percent body fat, sum of skinfolds, haemoglobin concentration, haematocrit, maximum heart rate, maximum minute ventilation, maximum respiratory exchange ratio, anaerobic performance, endurance time to fatigue (at 90% of VO₂max), or isokinetic strength of knee flexion and extension in between the luteal and follicular phases, corroborating the current thesis chapter findings. In contradiction, a study with daily bodyweight measurements, in 28-young-women, found highest bodyweight in the late luteal phase and at the first days of menstruation, followed by an abrupt weight loss. A short peak in bodyweight just after ovulation was also found by the authors (Watson and Robinson, 1965). The increase in body weight across the menstrual cycle might be related to fluid retention. A study examining one-year data of daily self-reported "bloating" found peak retention also on the first day of menstrual flow, but neither oestradiol nor progesterone levels was significantly associated with this retention (White et al., 2011).

The absence of anthropometric and structural differences in the present study provided a clue for the expectation that functional differences would also not be found. Indeed, results did not show differences in the vertical jump and flexibility variables. Bell et al., (2009) tested performance within three days after the onset of menses and ovulation and found that

hamstring muscle stiffness did not change across the menstrual cycle, contradicting these authors, hamstring extensibility was found to be increased at ovulation, when oestrogen concentration increases, corroborating other authors (Burgess et al., 2009).

Although some studies suggest that muscle strength is related to the oestrogen peak (Sarwar et al., 1996, Burgess et al., 2010), others report increased incidence of anterior cruciate ligament injuries (Wojtys et al., 1998) due to the increased compliance of the tendon (Heitz et al., 1999). Although no significant hormonal differences were found across the menstrual cycle in the current study (Table 57), a difference in the concentrations can be noticed (Figure 55), providing an indication of possible difference with bigger sample size, increasing the power of the study. Notwithstanding this, no other strength-related variable differed between the phases. Phillips et al. (1996) measured muscle strength throughout the menstrual cycle detecting the ovulation by urine luteinizing hormone measurements or change in basal body temperature. Significant increase in the strength was reported during the follicular phase, when the oestrogen levels are rising, and a significant drop around the time of ovulation. Nevertheless, no correlation between the plasma oestrogen and the force was found; it was suggested that the oestrogen action on the muscle might take hours or days to occur. Contradicting the previous authors, (Abt et al., 2007) found that neuromuscular and biomechanical characteristics were not influenced by oestradiol and progesterone fluctuations, despite changes in the concentration of oestrogen and progesterone. In addition, (Chaudhari et al., 2007) concluded that variations of the menstrual cycle and the use of an oral contraceptive do not affect knee or hip joint loading during jumping and landing tasks. The comparison between the studies needs to be done carefully, progesterone concentrations, for example, are highest in the morning (Syrop and Hammond, 1987), in addition, exercise is known to increase both oestrogen and progesterone concentrations (Keizer and Rogol, 1990, Jurkowski et al., 1978), therefore, many confounding variables need to be considered for comparison among studies.

The ROM_{Max} was statistically different between the limbs across all phases, however, no difference between the phases was found. This result corroborates the findings from previous chapters, showing asymmetries in flexibility between the limbs. In addition, the lack of difference when the deltas $[(D-nD)/D]$ were compared indicate that this asymmetry level

does not vary across the menstrual cycle phases. Hence, if ROM is affected by the variation in the circulating hormonal levels, both limbs beside the ROM levels, are equally affected. A similar result for the other variables delta was found.

Moreover, the Total PASS was showed to be greater in the ovulatory phase compared to the Luteal, with no difference between the other phases, while the PASS Physiological Anxiety subscale presented higher scores at the Ovulatory compared to any other phase. The higher score reported in the ovulatory phase suggests greater fearful appraisals of pain (Zvolensky et al., 2001), at least in our current sample. Although the PASS Physiological Anxiety subscale is related to the bodily reaction when experiencing or anticipating pain and was shown to be higher at ovulation, corroborating the pain research across the menstrual cycle, neither the $\text{torque}_{\text{Max}}$ nor the $\text{FSS}_{\text{torque}}$, variables associated with the stretch tolerance, were showed to be different between the phases or the limbs. Given that the stretch pain is defined as pain associated with stretch stimulations in soft tissue such as the skeletal muscles are stretched, the control of stretch pain is necessary to increase the range of motion (Morishita et al., 2014). Although each one of the menstrual phases may be related to a variety of behavioural outcomes, from the perception of attention, memory, and pain (Hoeger Bement et al., 2009; (Kowalczyk et al., 2006) Nielsen, Ahmed, & Cahill, 2014; Pletzer, Petasis, & Cahill, 2014) to calorie intake and drug use (Brennan et al., 2009; Carpenter, Upadhyaya, LaRowe, Saladin, & Brady, 2006; Holdstock & de Wit, 2000; Reed, Levin, & Evans, 2010; Reed, Evans, Bedi, Rubin, & Foltin, 2011; Reed, Levin, & Evans, 2008), none of those factors appears to affect flexibility across the phases. It is important to remember that these facts are assumptions, given that no differences in the group mean raw hormonal levels were found in the current chapter.

8.5.2 Relative change analyses

In order to deemphasize the inter-individual variability of results (potentially linked to the small samples assize as well as being a predictable physiological phenomenon), analyses were then carried out whereby each participant's change in outcome variable was quantified. A ratio of all dependent variables and hormone concentrations was performed using values from the Follicular phase as the baseline. The follicular phase was chosen to be the baseline for the ratio to the other phases because both, progesterone and oestrogen

levels, are expected to be low, therefore, changes could be highlighted in the following phases. In addition, between menstrual cycle phase differences in these relative changes were statistically assessed. What is more, where those changes were significant, they were then correlated against relative changes in hormones within each female. It was thus highly informative to find a substantial number of significant associations, potentially indicative of a causal effect of hormones on these outcome variables. Although no difference in the hormonal concentration was found across the menstrual cycle phases, Δ oestrogen_{Luteal/Follicular} was negatively correlated with Δ muscle length, Δ muscle CSA, Δ fat thickness and Δ muscle activity (EMG) during the CMJ. While Δ oestrogen_{Ovulatory/Follicular} was positively correlated with Δ ST thickness, Δ FSS_{torque} and Δ CMJ EMG_{RF}. Interestingly, Δ progesterone showed the opposite behaviour for similar variables, showing to be positively correlated when oestrogen was negatively correlated and negatively correlated when oestrogen was positively correlated. These results, the direction of the correlations and the dependent variables that the hormones are correlated corroborate findings from the previous chapters and from literature suggesting an MTC loosening effect of oestrogen and a tightening effect of progesterone. Although relaxin is more prominent after pregnancy, its variation seems to be related to the laxity of the tissue. Corroborating previous literature (Dragoo et al., 2011). In addition, relaxin was the only hormone which presented a significant difference between the variation between Ovulation/Follicular and Luteal/Follicular (see Table 63).

8.6 Conclusion

No differences were found between legs across the MCP. Additionally, no differences were found in the circulating female hormones were found across the menstrual cycle phases, potentially highlight the irregularity of menstrual cycle phases in dancers. Nevertheless, it is key to note that the relative individual changes in hormonal level found in the current chapter were associated with the majority of the relative changes in the key outcome measures including the structural and functional characteristics of the muscle tendon-unit.

Overarching Discussion

“Construímos muros demais e pontes de menos.”

Isaac Newton

“We build too many walls and not enough bridges.”

Isaac Newton

Flexibility has been studied mainly in the rehabilitation field, where injured people would need to stretch to regain decreased ROM due to injury (Pradines et al., 2016). Consequently, methods to improve the efficiency of stretching become necessary and were performed in several populations (Herda et al., 2010a, Feland et al., 2001, Cabido et al., 2014, Herda et al., 2008, Davis et al., 2005). Only recently, however, populations for whom flexibility is a crucial capability, such as dancers, started to be studied (Pessali-Marques, 2015, Pessali-Marques et al., 2016, Smith et al., 2013, Wyon et al., 2009). One of the difficulties in studying high flexible populations is the lack of equipment able to reach the maximal ROM performed by such participants (Pessali-Marques, 2016). Therefore, the development of equipment was necessary and drove the creation of the Flexibility Test Equipment (FTE) (described in Chapter 1 of this thesis), not only to measure, but also to train high flexible populations.

The ROM is usually the variable used to represent flexibility as a capability, however, according to previous authors (Weppeler and Magnusson, 2010), the response of the MTU to the stretch should be studied in a multidimensional approach. Although previous research (Aquino, 2010) reinforce this perspective, only a few studies were found in the best of the author's knowledge, measuring all of the dimensions: time, ROM, torque and CSA (Magnusson et al., 1997, Ryan et al., 2010). Therefore, the $\text{torque}_{\text{Max}}$, FSS_{ROM} , $\text{FSS}_{\text{torque}}$ and stiffness, normalized by the CSA, were measured in the current study, beyond the ROM_{Max} , in order to provide additional information considering the sensory and the biomechanical properties of the tissue. In addition, the number of factors that might affect the final flexibility performance has been raised, such as hormonal concentration of female hormones in different phases of the menstrual cycle, structural and functional characteristics of the MTU, as well as pain tolerance and coping strategies. Accordingly, the number of capabilities that flexibility level ultimately affects, such as jump and muscle stiffness, indicate that the modification of the ROM, on its own, is not enough to provide information on how to train participants that require flexibility as a fundamental capability, nor information regarding the MTU response to stretching. Hence, the FTE followed previous literature recommendation to measure the MTU response to stretching in a multidimensional approach, taking into consideration the biomechanical and sensory properties of the tissue. The FTE was shown to be reliable and accurate for all the measurements.

Once equipped, it was necessary to understand if the MTU response to stretch in trained in flexibility populations would be similar when compared to non-trained in flexibility populations considering many aspects that could affect flexibility and aspects that flexibility could further affect, such as jump performance (Chapter 2). Therefore, not only the performance in flexibility and jump capabilities and the functional characteristics of the muscle-tendon unit but also the structural characteristics were assessed aiming to characterise and differentiate these populations. This approach was deemed relevant because, if dancers respond differently for the same intervention compared to non-dancers, dissimilar training protocols would be fundamental for performance enhancement in dance. Results from Chapter 2 indicated that undergraduate contemporary dance students were not very different than undergraduate sport science students (results are shown in Table 63). However, the anthropometric similarity between participants and the fact that the undergraduate sport science students were also active in sport modalities which require jumping, might have hidden any possible differences. Larger sample size or more distinct populations in term of habitual physical activity levels, such as sedentary people compared with professional dancers, might provide additional information for discussion.

In line with the above, a study comparing professional dancers with sedentary non-dancers found greater menstrual irregularities in the dancers' group (Doyle-Lucas et al., 2010). No studies, in the best of the author's knowledge were found comparing detailed body composition in professional and student dancers. However, a study comparing BMI and nutritional knowledge found greater BMI professional dancers than in student dancers, where the BMI was related to better nutritional knowledge (Wyon et al., 2014). Another study assessed the effect of dance training on the menstrual patterns of 98 collegiate dancers and found that 72% of the dancers were eumenorrhic, 15.4% oligomenorrhic and 13.4% amenorrhic. Both oligomenorrhic and amenorrhic students had a lower body mass index and a higher incidence of musculoskeletal injuries and chronic orthopaedic problems compared to eumenorrhic age-matched ones. Ballet students had a higher incidence of menstrual dysfunction and musculoskeletal injuries compared to classical Chinese dance, modern dance and musical theatre dance students as well as a significantly lower average body mass index (To et al., 1995). Therefore, it can be hypothesised that the intensity of dance training rather than the level of professionalization or even the dance

style might be directly related to menstrual irregularities. Supporting this hypothesis, (Micheli et al., 2005) compared pre-season to post-season changes in body composition of professional ballet dancers and found significant decrease in both body weight and percentage of body fat in the female dancers in the post-season, when intensity was higher, while no modifications in body composition was found in male dancers. Although participants of this study trained at least 10 hours per week, the intensity of their training was self-reported to be low due to investment in creation and choreography rather than technique.

It is important to highlight that student dancers assessed in this study showed to be not physically prepared for the requirements of professional-level dancing. It was expected that student dancers, with a minimum 10 hours of dance practice per week would present high-level performance in both flexibility and jump compared to non-dancers, even if the latter, are habitually physically active. Although ROM_{Max} , $torque_{Max}$ and FSS_{ROM} and energy were greater for dancers, no differences in the S_{MTU} or any other variable, including jump performance, were significantly different compared to students that performed recreational sports activities. In addition, the BMI, fat and lean percentages were higher in the dance students compared to other dance student populations from previous literature (Abraham et al., 1982, Kadel et al., 2005, Angioi et al., 2009a).

The differences found in the ROM between the populations, however, led to analysing in more depth the dancers' response to stretch intervention. It was also of interest to confirm whether any level of asymmetry could affect other capabilities, such as jump. As a result of these questions, the kinetic (Chapter 3) and the kinematic (Chapter 4) variables were analysed before stretching both limbs, as well as after a stretch protocol in one limb only. Therefore, the effect of asymmetries could also be studied. The hypothesis that stretch interventions could enhance any asymmetry already existent between limbs was raised based on the results of previous studies comparing more and less flexible participants. These studies found that more flexible participants presented a greater decrease in the S_{MTU} after training, therefore, it was expected that the more flexible limb would also present greater decrease in the S_{MTU} compared to the less flexible limb after stretching (Magnusson et al., 1997, Blazeovich et al., 2012). However, these studies were compared different populations,

while, in the best of the author's knowledge, this is the first study that compared the response to stretch between limbs (i.e. within-participant observations). The fact that most of the literature in flexibility tends to be limited to one limb and, in the case of vertical jumps, to the sum of both limbs, may bypass the observations of existing bilateral asymmetries; which arguably, are related to injuries (Yoshioka et al., 2010, Kimmerle and Science, 2010, Impellizzeri et al., 2007). When one limb only is going to be investigated in research, the assignment is usually given to the dominant limb, the right limb or the limb is chosen randomly (Cabido et al., 2014). However, there is a discussion regarding the definition of limb dominance in dance. While in many sports, such as football, the dominant limb is classed as the kicking limb, it is not clear in dance whether the dominant limb is the support or the limb chosen to perform the steps, also known as gesture limb (Kimmerle and Science, 2010). Additionally, it is unclear whether, in fact, the preferred limb (or dominant) may change according to the dance movement being performed. In addition, previous authors (Mertz et al., 2012) found that dancers' perception of the strongest limb does not correlate with the actual strength and maximum ground reaction forces (GRF_{Max}), reinforcing the suggestion that data obtained in flexibility, vertical jumps and strength should be reported for both the gesturing and the supporting limb in dancers (Kimmerle and Science, 2010). Therefore, the criteria to determine dominance and/or what limb should be studied needs to be objectively described. In the present study, the dominance, therefore, the stretch intervention, was established by the limb with the largest ROM achieved in the Pre-test for the flexibility capability. In addition, although the isokinetic dynamometer is considered the golden equipment for assessing lower limb strength asymmetries, Impellizzeri et al. (2007) assessed the validity of a vertical jump test for measuring the force produced by each limb. When comparing the peak vertical CMJ force to isokinetic leg extension and isometric leg press results, the authors found that the vertical jumps test was a valid and reliable method of measuring lower limb strength. This method involves taking the force reading for each limb hence needing two force plates or alternating limbs on one force plate. Given that the latter could affect the reliability as the two jumps could be different, the first option was performed in the current thesis.

The rationale behind the query about lower limbs asymmetry in dancers was due to studies showing that the characteristic repetitiveness of dance may be associated with imbalances

between muscle groups (Aquino, 2010). Hamilton et al. (1992) found inequality between muscular strengths of male and female dancers, mainly in the adductor and abductor muscles and internal and external rotators of the hip, with the latter being respectively more developed. Another group of researchers (Aquino, 2010) also found a difference in the strength of the Tensor Fascia Lata, which shortened by overload, can cause dysfunctions in the knees and Gupta et al. (2004) found a difference in strength in the external rotation of the hip in the leg, preferably in relation to the other. Although dance aims to work the body bilaterally, it is believed that there is more training on the choreography preferred side, which characterizes a unilateral practice increasing the chances of strength inequalities and even consequent postural deviations (Prati and Prati, 2006).

Results from Chapter 3 and 4 confirm the hypothesis that dancers present asymmetries in flexibility between the lower limbs, interestingly, the asymmetries in flexibility were not sufficient to cause alterations in any other variable, nor in jump performance. On the other hand, the assumption that dancers might control the proprioceptive system efficiently to guarantee the same level of performance adjusting body movement was raised (Chapter 4). This proprioceptive skill, however, might have masked the possible influence of the stretch intervention in the remaining variables. Vanezis and Lees (2005) raised the idea that dancers' technique used together with the coordination of body segments could enable individuals to perform better without greater strength capabilities of muscles. However, the authors concluded that superior performance on vertical jumps was due to greater muscle capability in terms of strength and rate of strength development in all lower limb joints rather than to technique.

Studies that found decrease in jump performance after static stretch suggest that performance was probably impaired through mechanical and neurological mechanisms such as reduced S_{MTU} (Herda et al., 2010a, Morse et al., 2008, Kato et al., 2010), altered reflex sensitivity (Avela et al., 1999, Avela and Komi, 1998b, Komi et al., 1996), and decreased muscle activation (Silveira et al., 2011, Ryan et al., 2008a). None of these variables, however, showed modification after the stretch intervention applied in Chapter 3 and 4. The lack of difference caused by the intervention in the most flexible limb and the increase in the

control limb, which did not undergo any stretching raised important questions about neurological mechanisms related to stretch and force production between both limbs.

Previous research concerning flexibility have applied stretch interventions to one lower limb, randomly selected, while the contralateral limb is used as control (Ylinen et al., 2009, Magnusson et al., 1996a). Other studies have applied different protocols to each limb for comparison (Chagas et al., 2008, Magnusson et al., 1996b) and others used both lower limbs as independent samples (Cabido et al., 2014). The majority of the studies, however, did not in fact report what limb was chosen (Halbertsma and Göeken, 1994, Kay and Blazeovich, 2010, Hoge et al., 2010, Herda et al., 2008). According to the results in Chapters 3 and 4, due to asymmetries in flexibility between the limbs (also found in non-dancers – Chapter 2) the choice of what lower limb to use for comparison among groups needs to be done more objectively, given that subjects (either participants or limbs) might present different training response according to their inherent stretch abilities. This assumption was corroborated by previous studies showing different response in distinct groups (Pessali-Marques, 2015, Blazeovich et al., 2012, Nielsen et al., 1993). Another interesting and unexpected result is that due to the lack of difference in the force generation between lower limbs with different ROM a sarcomeroneogenesis might have occurred. The increase in the number of sarcomeres can be measured in vivo using ultrasound (Maganaris, 2001) and should be performed in further studies. It is important to highlight that according to the results of the current study, stretching just the most flexible limb appears to decrease asymmetry rather than increase it. The reasons for this decrease still need to be investigated, however, the influence of the Central Nervous System might play a role.

Finally, although a great number of dancers are female, most of the flexibility studies were performed with males. It was thus unknown whether the menstrual cycle hormones variation would affect the flexibility in each phase. Oestrogen, progesterone and relaxin levels were followed across one cycle to verify the hormonal effect on flexibility, jump and pain. Results from Chapter 5 showed a lack of variation of oestrogen, progesterone and relaxin between the ovulatory, follicular and luteal phases of the menstrual cycle contradicting previous studies (Fehring et al., Treloar et al., 1967, Lebrun et al., 1995). The lack of difference, however, highlighted the fact that dancers present irregular menstrual

cycle (Frisch et al., 1980, Brooks-Gunn et al., 1987, Warren et al., 2002, Warren et al., 2003) in addition to the difficulties of reaching the peak hormonal phase and to compare the results with the literature. There are discrepancies in the terminology used for different phases of the menstrual cycle among studies; The follicular phase, for example, is more variable in length than the luteal phase, therefore, if not referred as early, mid or late follicular, in which low oestrogen and low progesterone, rising oestrogen and low progesterone, and, high oestrogen and low progesterone, respectively, the body may be affected differently without any clear physiological pathway (Xanne and De Jonge, 2003).

Although no significant group variation in the concentration of hormones across the phases was found a negative correlation between progesterone and flexibility and a negative correlation of oestrogen and jump variables are in accordance with the role the hormones are suggested to perform. Indeed, oestrogen and relaxin were both associated with increased compliance of the MTU, whilst progesterone, on the other hand, was associated with increased muscle stiffness. Interestingly, relaxin was correlated with even more outcome variables than oestrogen or progesterone and was the only hormone which presented a significant difference in the variation between Ovulation/Follicular and Luteal/Follicular phases, highlighting its important role on MTU laxity beyond pregnancy time. Table 65, below, present a summary of all data gathered in the present thesis.

Table 65: Summary of the data Chapters results

Variable	Chapter 2 DCN vs NN D LL vs nD LL	Chapter 3 Pre- vs Post-test Training vs Control	Chapter 4 Pre- vs Post-test Training vs Control	Chapter 5 Ovulatory vs Luteal vs follicular D LL vs nD LL
ROM_{Max}	DCN > NN D LL > nD LL	Post-test = Pre-test T Post-test > Pre-test C Pre-test T > C Post-test T > C	-	D Follicular = D ovulatory D Follicular = D Luteal D Ovulatory = D Luteal nD Follicular = nD ovulatory nD Follicular = nD Luteal nD Ovulatory = nD Luteal D Follicular nD Follicular D Ovulatory nD Ovulatory D Luteal nD Luteal
Torque_{Max}	DCN > NN D LL = nD LL	Post-test = Pre-test T Post-test = Pre-test C Pre-test T > C Post-test T > C	-	D Follicular = D ovulatory D Follicular = D Luteal D Ovulatory = D Luteal nD Follicular = nD ovulatory nD Follicular = nD Luteal nD Ovulatory = nD Luteal

				D Follicular = nD Follicular D Ovulatory = nD Ovulatory D Luteal = nD Luteal
FSS_{ROM}	DCN > NN D LL = nD LL	Post-test = Pre-test T Post-test = Pre-test C Pre-test T = C Post-test T = C	-	D Follicular = D ovulatory D Follicular = D Luteal D Ovulatory = D Luteal nD Follicular = nD ovulatory nD Follicular = nD Luteal nD Ovulatory = nD Luteal D Follicular = nD Follicular D Ovulatory = nD Ovulatory D Luteal = nD Luteal
FSS_{torque}	DCN = NN D LL = nD LL	Post-test = Pre-test T Post-test = Pre-test C Pre-test T = C Post-test T = C	-	D Follicular D ovulatory D Follicular D Luteal D Ovulatory D Luteal nD Follicular nD ovulatory nD Follicular nD Luteal nD Ovulatory nD Luteal D Follicular nD Follicular D Ovulatory nD Ovulatory D Luteal nD Luteal
S_{MTU}	DCN = NN D LL = nD LL	Post-test = Pre-test T Post-test = Pre-test C Pre-test T = C Post-test T = C	-	D Follicular D ovulatory D Follicular D Luteal D Ovulatory D Luteal nD Follicular nD ovulatory nD Follicular nD Luteal nD Ovulatory nD Luteal D Follicular nD Follicular D Ovulatory nD Ovulatory D Luteal nD Luteal
Energy	DCN > NN D LL = nD LL	Post-test = Pre-test T Post-test = Pre-test C Pre-test T = C Post-test T = C	-	D Follicular = D ovulatory D Follicular = D Luteal D Ovulatory = D Luteal nD Follicular = nD ovulatory nD Follicular = nD Luteal nD Ovulatory = nD Luteal D Follicular = nD Follicular D Ovulatory = nD Ovulatory D Luteal = nD Luteal
CMJ V_{take-off}	DCN = NN	Post-test = Pre-test	-	Follicular = Ovulatory Follicular = Luteal Ovulatory = Luteal
CMJ Jump height	DCN = NN	Post-test = Pre-test	-	Follicular = Ovulatory Follicular = Luteal Ovulatory = Luteal
CMJ total impulse	DCN = NN D LL = nD LL	Post-test = Pre-test	-	Follicular = Ovulatory Follicular = Luteal Ovulatory = Luteal
CMJ total force_{peak}	DCN = NN	Post-test = Pre-test	-	Follicular = Ovulatory Follicular = Luteal Ovulatory = Luteal
CMJ force_{peak}	DCN = NN D LL > nD LL (DCN) D LL > nD LL (NN)	Post-test = Pre-test T Post-test = Pre-test C Pre-test T = C Post-test T = C	-	D Follicular = D ovulatory D Follicular = D Luteal D Ovulatory = D Luteal nD Follicular = nD ovulatory nD Follicular = nD Luteal nD Ovulatory = nD Luteal

				D Follicular = nD Follicular D Ovulatory = nD Ovulatory D Luteal = nD Luteal
CMJ impulse	DCN = NN D LL > nD LL (DCN) D LL = nD LL (NN)	Post-test = Pre-test T Post-test = Pre-test C Pre-test T = C Post-test T = C	-	D Follicular = D ovulatory D Follicular = D Luteal D Ovulatory = D Luteal nD Follicular = nD ovulatory nD Follicular = nD Luteal nD Ovulatory = nD Luteal D Follicular = nD Follicular D Ovulatory = nD Ovulatory D Luteal = nD Luteal
SJ V_{take-off}	DCN = NN	Post-test = Pre-test	-	Follicular = Ovulatory Follicular = Luteal Ovulatory = Luteal
SJ Jump height	DCN = NN	Post-test = Pre-test	-	Follicular = Ovulatory Follicular = Luteal Ovulatory = Luteal
SJ total impulse	DCN = NN	Post-test = Pre-test	-	Follicular = Ovulatory Follicular = Luteal Ovulatory = Luteal
SJ total force_{peak}	DCN > NN D LL = nD LL	Post-test < Pre-test	-	Follicular = Ovulatory Follicular = Luteal Ovulatory = Luteal
SJ force_{peak}	DCN = NN D LL > nD LL (DCN) D LL = nD LL (NN)	Post-test = Pre-test T Post-test < Pre-test C Pre-test T = C Post-test T < C	-	D Follicular = D ovulatory D Follicular = D Luteal D Ovulatory = D Luteal nD Follicular = nD ovulatory nD Follicular = nD Luteal nD Ovulatory = nD Luteal D Follicular = nD Follicular D Ovulatory = nD Ovulatory D Luteal = nD Luteal
SJ impulse	DCN = NN D LL = nD LL (DCN) D LL = nD LL (NN)	Post-test = Pre-test T Post-test = Pre-test C Pre-test T = C Post-test T = C	-	D Follicular = D ovulatory D Follicular = D Luteal D Ovulatory = D Luteal nD Follicular = nD ovulatory nD Follicular = nD Luteal nD Ovulatory = nD Luteal D Follicular = nD Follicular D Ovulatory = nD Ovulatory D Luteal = nD Luteal
CMJ EMG_{ST}	DCN = NN D LL = nD LL (DCN) D LL = nD LL (NN)	-	Post-test = Pre-test T Post-test = Pre-test C Pre-test T = C Post-test T = C	D Follicular = D ovulatory D Follicular = D Luteal D Ovulatory = D Luteal nD Follicular = nD ovulatory nD Follicular = nD Luteal nD Ovulatory = nD Luteal D Follicular = nD Follicular D Ovulatory = nD Ovulatory D Luteal = nD Luteal
CMJ EMG_{RF}	DCN = NN D LL = nD LL (DCN) D LL < nD LL (NN)	-	Post-test = Pre-test T Post-test = Pre-test C Pre-test T = C Post-test T = C	D Follicular = D ovulatory D Follicular = D Luteal D Ovulatory = D Luteal nD Follicular = nD ovulatory nD Follicular = nD Luteal nD Ovulatory = nD Luteal

				D Follicular = nD Follicular D Ovulatory = nD Ovulatory D Luteal = nD Luteal
SJ EMG_{ST}	DCN = NN (nD LL) DCN < NN (D LL) D LL = nD LL (DCN) D LL = nD LL (NN)	-	Post-test = Pre-test T Post-test = Pre-test C Pre-test T = C Post-test T = C	D Follicular = D ovulatory D Follicular = D Luteal D Ovulatory = D Luteal nD Follicular = nD ovulatory nD Follicular = nD Luteal nD Ovulatory = nD Luteal D Follicular = nD Follicular D Ovulatory = nD Ovulatory D Luteal = nD Luteal
SJ EMG_{RF}	DCN = NN D LL = nD LL (DCN) D LL = nD LL (NN)	-	Post-test = Pre-test T Post-test = Pre-test C Pre-test T = C Post-test T = C	D Follicular = D ovulatory D Follicular = D Luteal D Ovulatory = D Luteal nD Follicular = nD ovulatory nD Follicular = nD Luteal nD Ovulatory = nD Luteal D Follicular = nD Follicular D Ovulatory = nD Ovulatory D Luteal = nD Luteal
CSA	DCN = NN D LL = nD LL	-	-	D Follicular = D ovulatory D Follicular = D Luteal D Ovulatory = D Luteal nD Follicular = nD ovulatory nD Follicular = nD Luteal nD Ovulatory = nD Luteal D Follicular = nD Follicular D Ovulatory = nD Ovulatory D Luteal = nD Luteal
Fat thickness	DCN = NN D LL = nD LL (DCN) D LL = nD LL (NN)	-	-	D Follicular = D ovulatory D Follicular = D Luteal D Ovulatory = D Luteal nD Follicular = nD ovulatory nD Follicular = nD Luteal nD Ovulatory = nD Luteal D Follicular = nD Follicular D Ovulatory = nD Ovulatory D Luteal = nD Luteal
ST thickness	DCN = NN D LL = nD LL (DCN) D LL = nD LL (NN)	-	-	D Follicular = D ovulatory D Follicular = D Luteal D Ovulatory = D Luteal nD Follicular = nD ovulatory nD Follicular = nD Luteal nD Ovulatory = nD Luteal D Follicular = nD Follicular D Ovulatory = nD Ovulatory D Luteal = nD Luteal
Lean thickness	DCN = NN D LL = nD LL (DCN) D LL = nD LL (NN)	-	-	D Follicular = D ovulatory D Follicular = D Luteal D Ovulatory = D Luteal nD Follicular = nD ovulatory nD Follicular = nD Luteal nD Ovulatory = nD Luteal D Follicular = nD Follicular D Ovulatory = nD Ovulatory D Luteal = nD Luteal

Muscle width	DCN = NN D LL = nD LL (DCN) D LL = nD LL (NN)	-	-	D Follicular = D ovulatory D Follicular = D Luteal D Ovulatory = D Luteal nD Follicular = nD ovulatory nD Follicular = nD Luteal nD Ovulatory = nD Luteal D Follicular = nD Follicular D Ovulatory = nD Ovulatory D Luteal = nD Luteal
Muscle length	DCN < NN D LL = nD LL	-	-	D Follicular = D ovulatory D Follicular = D Luteal D Ovulatory = D Luteal nD Follicular = nD ovulatory nD Follicular = nD Luteal nD Ovulatory = nD Luteal D Follicular = nD Follicular D Ovulatory = nD Ovulatory D Luteal = nD Luteal
Total PASS score	DCN = NN	-	-	Follicular = Ovulatory Follicular = Luteal Ovulatory > Luteal
Mode PASS score	DCN = NN	-	-	Follicular = Ovulatory Follicular = Luteal Ovulatory = Luteal
PASS cog anx	DCN = NN	-	-	Follicular = Ovulatory Follicular = Luteal Ovulatory = Luteal
PASS escape	DCN = NN	-	-	Follicular = Ovulatory Follicular = Luteal Ovulatory = Luteal
PASS fear	DCN = NN	-	-	Follicular = Ovulatory Follicular = Luteal Ovulatory = Luteal
PASS physio	DCN = NN	-	-	Follicular < Ovulatory Follicular = Luteal Ovulatory > Luteal
Total SEFIP	DCN = NN	-	-	Follicular = Ovulatory Follicular = Luteal Ovulatory = Luteal
Mode SEFIP	DCN = NN	-	-	Follicular = Ovulatory Follicular = Luteal Ovulatory = Luteal
IWT duration	DCN = NN	-	-	Follicular = Ovulatory Follicular = Luteal Ovulatory = Luteal
Progesterone	DCN = NN	-	-	Follicular = Ovulatory Follicular = Luteal Ovulatory = Luteal
Oestrogen	DCN = NN	-	-	D Follicular = D ovulatory D Follicular = D Luteal D Ovulatory = D Luteal nD Follicular = nD ovulatory nD Follicular = nD Luteal nD Ovulatory = nD Luteal D Follicular = nD Follicular D Ovulatory = nD Ovulatory D Luteal = nD Luteal

Relaxin	DCN = NN	-	-	D Follicular = D ovulatory D Follicular = D Luteal D Ovulatory = D Luteal nD Follicular = nD ovulatory nD Follicular = nD Luteal nD Ovulatory = nD Luteal D Follicular = nD Follicular D Ovulatory = nD Ovulatory D Luteal = nD Luteal
Ankle Angle Preparatory Squat CMJ	-	-	Post-test = Pre-test T Post-test = Pre-test C Pre-test T = C Post-test T = C	-
Hip Angle Preparatory Squat CMJ	-	-	Post-test = Pre-test T Post-test = Pre-test C Pre-test T = C Post-test T = C	-
Knee Angle Preparatory Squat CMJ	-	-	Post-test < Pre-test T Post-test > Pre-test C Pre-test T > C Post-test T = C	-
Ankle Angle Take-off CMJ	-	-	Post-test = Pre-test T Post-test = Pre-test C Pre-test T = C Post-test T = C	-
Hip Angle Take-off CMJ	-	-	Post-test = Pre-test T Post-test = Pre-test C Pre-test T = C Post-test T = C	-
Knee Angle Take-off CMJ	-	-	Post-test = Pre-test T Post-test = Pre-test C Pre-test T = C Post-test T = C	-
Ankle Angle Landing CMJ	-	-	Post-test = Pre-test T Post-test = Pre-test C Pre-test T = C Post-test T = C	-
Hip Angle Landing CMJ	-	-	Post-test = Pre-test T Post-test = Pre-test C Pre-test T = C Post-test T = C	-

Knee Angle Landing CMJ	-	-	Post-test = Pre-test T Post-test = Pre-test C Pre-test T = C Post-test T = C	-
Ankle Angle Landing Squat CMJ	-	-	Post-test = Pre-test T Post-test = Pre-test C Pre-test T = C Post-test T = C	-
Hip Angle Landing Squat CMJ	-	-	Post-test = Pre-test T Post-test = Pre-test C Pre-test T = C Post-test T = C	-
Knee Angle Landing Squat CMJ	-	-	Post-test = Pre-test T Post-test = Pre-test C Pre-test T = C Post-test T = C	-
Ankle Angle Preparatory Squat SJ	-	-	Post-test = Pre-test T Post-test = Pre-test C Pre-test T = C Post-test T = C	-
Hip Angle Preparatory Squat SJ	-	-	Post-test = Pre-test T Post-test = Pre-test C Pre-test T = C Post-test T = C	-
Knee Angle Preparatory Squat SJ	-	-	Post-test = Pre-test T Post-test = Pre-test C Pre-test T > C Post-test T > C	-
Ankle Angle Take-off SJ	-	-	Post-test = Pre-test T Post-test = Pre-test C Pre-test T = C Post-test T = C	-
Hip Angle Take-off SJ	-	-	Post-test = Pre-test T Post-test = Pre-test C Pre-test T = C Post-test T > C	-
Knee Angle Take-off SJ	-	-	Post-test = Pre-test T	-

			Post-test = Pre-test C Pre-test T = C Post-test T = C	
Ankle Angle Landing SJ	-	-	Post-test = Pre-test T Post-test = Pre-test C Pre-test T = C Post-test T = C	-
Hip Angle Landing SJ	-	-	Post-test = Pre-test T Post-test = Pre-test C Pre-test T = C Post-test T = C	-
Knee Angle Landing SJ	-	-	Post-test = Pre-test T Post-test = Pre-test C Pre-test T = C Post-test T = C	-
Ankle Angle Landing Squat SJ	-	-	Post-test = Pre-test T Post-test = Pre-test C Pre-test T = C Post-test T = C	-
Hip Angle Landing Squat SJ	-	-	Post-test = Pre-test T Post-test = Pre-test C Pre-test T = C Post-test T = C	-
Knee Angle Landing Squat SJ	-	-	Post-test = Pre-test T Post-test = Pre-test C Pre-test T = C Post-test T = C	-
Ankle Angular Velocity Eccentric CMJ	-	-	Post-test = Pre-test T Post-test = Pre-test C Pre-test T = C Post-test T = C	-
Ankle Angular Velocity Concentric CMJ	-	-	Post-test < Pre-test T Post-test = Pre-test C Pre-test T = C Post-test T > C	-
Hip Angular Velocity Eccentric CMJ	-	-	Post-test = Pre-test T Post-test = Pre-test C Pre-test T = C	-

			Post-test T = C	
Hip Angular Velocity Concentric CMJ	-	-	Post-test = Pre-test T Post-test = Pre-test C Pre-test T = C Post-test T = C	-
Knee Angular Velocity Eccentric CMJ	-	-	Post-test < Pre-test T Post-test < Pre-test C Pre-test T = C Post-test T = C	-
Knee Angular Velocity Concentric CMJ	-	-	Post-test = Pre-test T Post-test = Pre-test C Pre-test T = C Post-test T = C	-
Ankle Angular Velocity Eccentric SJ	-	-	Post-test = Pre-test T Post-test = Pre-test C Pre-test T = C Post-test T = C	-
Ankle Angular Velocity Concentric SJ	-	-	Post-test = Pre-test T Post-test = Pre-test C Pre-test T < C Post-test T < C	-
Hip Angular Velocity Eccentric SJ	-	-	Post-test = Pre-test T Post-test = Pre-test C Pre-test T = C Post-test T = C	-
Hip Angular Velocity Concentric SJ	-	-	Post-test = Pre-test T Post-test = Pre-test C Pre-test T < C Post-test T < C	-
Knee Angular Velocity Eccentric SJ	-	-	Post-test = Pre-test T Post-test = Pre-test C Pre-test T = C Post-test T = C	-
Knee Angular Velocity Concentric SJ	-	-	Post-test > Pre-test T Post-test < Pre-test C Pre-test T < C Post-test T < C	-
ΔROM_{Max}	-	T = C	-	Follicular = Ovulatory Follicular = Luteal

				Ovulatory = Luteal
$\Delta \text{torque}_{\text{Max}}$	-	T = C	-	Follicular = Ovulatory Follicular = Luteal Ovulatory = Luteal
$\Delta \text{FSS}_{\text{ROM}}$	-	T = C	-	Follicular = Ovulatory Follicular = Luteal Ovulatory = Luteal
$\Delta \text{FSS}_{\text{torque}}$	-	T = C	-	Follicular = Ovulatory Follicular = Luteal Ovulatory = Luteal
$\Delta \text{S}_{\text{MTU}}$	-	T = C	-	Follicular = Ovulatory Follicular = Luteal Ovulatory = Luteal
ΔEnergy	-	T < C	-	Follicular = Ovulatory Follicular = Luteal Ovulatory = Luteal
$\Delta \text{CMJ Impulse}$	-	T = C	-	Follicular = Ovulatory Follicular = Luteal Ovulatory = Luteal
$\Delta \text{CMJ Force}_{\text{peak}}$	-	T = C	-	Follicular = Ovulatory Follicular = Luteal Ovulatory = Luteal
$\Delta \text{SJ Impulse}$	-	T = C	-	Follicular = Ovulatory Follicular = Luteal Ovulatory = Luteal
$\Delta \text{SJ Force}_{\text{peak}}$	-	T < C	-	Follicular = Ovulatory Follicular = Luteal Ovulatory = Luteal
ΔLength	-	-	-	Follicular = Ovulatory Follicular = Luteal Ovulatory = Luteal
ΔWidth	-	-	-	Follicular = Ovulatory Follicular = Luteal Ovulatory = Luteal
ΔCSA	-	-	-	Follicular = Ovulatory Follicular = Luteal Ovulatory = Luteal
$\Delta \text{Fat thickness}$	-	-	-	Follicular = Ovulatory Follicular = Luteal Ovulatory = Luteal
$\Delta \text{ST thickness}$	-	-	-	Follicular = Ovulatory Follicular = Luteal Ovulatory = Luteal
$\Delta \text{Total Lean thickness}$	-	-	-	Follicular = Ovulatory Follicular = Luteal Ovulatory = Luteal
$\Delta \text{Ankle Angle Preparatory Squat CMJ}$	-	-	T = C	-
$\Delta \text{Hip Angle Preparatory Squat CMJ}$	-	-	T = C	-
$\Delta \text{Knee Angle Preparatory Squat}$	-	-	T = C	-

CMJ				
Δ Ankle Angle Take-off CMJ	-	-	T = C	-
Δ Hip Angle Take-off CMJ	-	-	T < C	-
Δ Knee Angle Take-off CMJ	-	-	T = C	-
Δ Ankle Angle Landing CMJ	-	-	T = C	-
Δ Hip Angle Landing CMJ	-	-	T = C	-
Δ Knee Angle Landing CMJ	-	-	T = C	-
Δ Ankle Angle Landing Squat CMJ	-	-	T = C	-
Δ Hip Angle Landing Squat CMJ	-	-	T = C	-
Δ Knee Angle Landing Squat CMJ	-	-	T = C	-
Δ Ankle Angle Preparatory Squat SJ	-	-	T = C	-
Δ Hip Angle Preparatory Squat SJ	-	-	T = C	-
Δ Knee Angle Preparatory Squat SJ	-	-	T = C	-
Δ Ankle Angle Take-off SJ	-	-	T < C	-
Δ Hip Angle Take-off SJ	-	-	T < C	-
Δ Knee Angle Take-off SJ	-	-	T = C	-
Δ Ankle Angle Landing SJ	-	-	T = C	-
Δ Hip Angle Landing SJ	-	-	T = C	-
Δ Knee Angle Landing SJ	-	-	T > C	-

SJ				
Δ Ankle Angle Landing Squat SJ	-	-	T = C	-
Δ Hip Angle Landing Squat SJ	-	-	T = C	-
Δ Knee Angle Landing Squat SJ	-	-	T = C	-
Δ Ankle Angular Velocity Eccentric CMJ	-	-	T = C	-
Δ Ankle Angular Velocity Concentric CMJ	-	-	T > C	-
Δ Hip Angular Velocity Eccentric CMJ	-	-	T = C	-
Δ Hip Angular Velocity Concentric CMJ	-	-	T < C	-
Δ Knee Angular Velocity Eccentric CMJ	-	-	T = C	-
Δ Knee Angular Velocity Concentric CMJ	-	-	T < C	-
Δ Ankle Angular Velocity Eccentric SJ	-	-	T < C	-
Δ Ankle Angular Velocity Concentric SJ	-	-	T = C	-
Δ Hip Angular Velocity Eccentric SJ	-	-	T = C	-
Δ Hip Angular Velocity Concentric SJ	-	-	T = C	-
Δ Knee Angular Velocity Eccentric SJ	-	-	T = C	-
Δ Knee Angular Velocity Concentric	-	-	T = C	-

SJ				
Δ CMJ EMG _{ST}	-	-	T = C	Follicular = Ovulatory Follicular = Luteal Ovulatory = Luteal
Δ CMJ EMG _{RF}	-	-	T = C	Follicular = Ovulatory Follicular = Luteal Ovulatory = Luteal
Δ SJ EMG _{ST}	-	-	T = C	Follicular = Ovulatory Follicular = Luteal Ovulatory = Luteal
Δ SJ EMG _{RF}	-	-	T = C	Follicular = Ovulatory Follicular = Luteal Ovulatory = Luteal

=: no statistically significant difference. > Statistically significant difference in which the first variable is greater than the second. < Statistically significant difference in which the first variable is smaller than the second. -: variable not analysed in the respective chapter. Grey cells: Interaction. Δ = (DIFPost-Pre)/Pre for Chapter 4 and (D-nD)/D for Chapter 5. CMJ: countermovement jump, SJ: Squat jump, ST: semitendinosus, RF: rectus femoris, v: velocity, CSA: Cross-sectional area, ROM: range of motion, Max: maximal FSS: first sensation of stretch, Cog Anx: Cognitive anxiety, IWT: Ice water test, S_{MTU} : muscle-tendon unit stiffness, EMG: Electromyography, V: velocity, SEFIP: Self-Estimated Functional Inability because of Pain, PASS: Pain Anxiety Symptom Scale, Esc: escape, T: Training condition, C: Control condition, D: dominant limb, nD: non-dominant-limb. DCN: Dancers, NN: Non-dancers.

Practical applications

According to results obtained in the current thesis, some practical applications may be suggested. The use of adequate equipment to measure flexibility in a multidisciplinary approach is necessary to assess the response of the muscle-tendon unit to stretch intervention, especially in hyper-flexible populations such as dancers. Thus, the further developed flexibility test apparatus in this thesis provide a reliable tool that can be commercialised for wider use. This is important because differences between limbs and between different populations might happen even though no alteration in flexibility levels (usually defined as ROM) are observed. These differences should be considered when prescribing flexibility training. Asymmetries in flexibility between the limbs were found in both dancers and non-dancers. The stretch intervention in the most flexible limb showed to decrease this asymmetry, probably due to neuromuscular responses, which also influenced the greater pain tolerance in the most flexible limb.

The menstrual cycle phase should be considered when prescribing training for both dancers and non-dancers. Even for participants under contraception, progesterone has a stiffening effect in the muscle-tendon unit while oestrogen has a loosening effect, either of which may affect jump and flexibility performance. However, the hormonal influence appears to be

muscle dependent. No differences were found in the impact of hormonal influence between the limbs thereby highlighting a generalised systemic effect of these ligands.

Studies limitations

Some limitations in the current research should be addressed. Firstly, regarding the sample size, a greater sample size would provide greater power confirming the results of this study, however, all women that fitted the inclusion criteria and agreed to participate in this study at the university were tested. Recruitment of additional participants was not possible due to financial limitations to help participants to commute to campus for tests. Secondly, the normalization of electromyographic data was performed using rest values rather than MVC. This decision was due to the duration of tests agreed with the ethics committee, which should not be longer than 3 hours. Therefore, additional tests such as maximal voluntary contractions before flexibility and jump tests were not possible in the available time frame for data collection. Although the use of MVCs is the most favoured method to normalize EMG data allowing comparison of activity levels between muscles in different individuals (Halaki and Ginn, 2012), the principle of normalization, which is to have a reference EMG value obtained from the same muscle that will perform a task, was reached. Thirdly, given that the stretching was performed flexing the hips with extended knees, activation of gastrocnemius should have been assessed. A number of previous studies have not found any difference in the EMG of the gastrocnemius during the straight leg test with different ankle positions (Gajdosik et al., 1985, Laudner et al., 2016). Other authors, however, highlight the influence of static stretching of the gastrocnemius muscles in the decrease of maximal jumping performance (Wallmann et al., 2005). We, therefore, recommend that future research aims to include the monitoring of EMG activity at this muscle site, in order to account for all possible variables contributing to joint flexibility during the straight leg stretch.

Recommendations for future work

Altogether, results from the current thesis instigate further research questions:

1. Given that no structural and functional differences were found between undergraduate dance and sport science students, comparisons between markedly

different populations, such as professional dancers and sedentary people, could provide different results. In addition, comparisons between dancers' specialists in different dance modalities, are also warranted.

2. Given that four series of stretching were not able to increase the ROM in the most flexible limb, what would be the ideal number of stretch series to fully accommodate the muscle tendon-unit in highly flexible subjects?
3. Since despite asymmetries in the lower limb were found, these asymmetries were not sufficient to modify force production during the vertical jumps, to analyse the number of sarcomeres between the lower limbs could provide an explanation for the lack of strength difference.
4. According to the trainability and the physiologic reserve principles, the more trained limb or participant would present lower modifications to intervention. However, no studies, in the best of the author's knowledge, were performed during chronic stretch training.
5. Finally, forasmuch as both limbs, independently of the asymmetry level they may present, are ruled by the same central nervous system. It is important to know if the training of one limb only would affect the contralateral limb.

References

- ABASIATTAI, A., UTUK, M., OJEH, S. & EYO, U. 2011. Combined oral contraceptive pills: Profile of acceptors in a tertiary hospital in South-South Nigeria. *Nigerian Medical Journal*, 52, 19.
- ABE, T., NAKATANI, M. & LOENNEKE, J. P. 2017. Relationship between ultrasound muscle thickness and MRI-measured muscle cross-sectional area in the forearm: a pilot study. *Clinical Physiology and Functional Imaging*.
- ABRAHAM, S. F., BEUMONT, P., FRASER, I. & LLEWELLYN-JONES, D. 1982. Body weight, exercise and menstrual status among ballet dancers in training. *An International Journal of Obstetrics Gynaecology*, 89, 507-510.
- ABT, J. P., SELL, T. C., LAUDNER, K. G., MCCRORY, J. L., LOUCKS, T. L., BERGA, S. L. & LEPHART, S. M. 2007. Neuromuscular and biomechanical characteristics do not vary across the menstrual cycle. *Knee Surgery, Sports Traumatology, Arthroscopy*, 15, 901-907.
- ABUBAKER, A. O., HEBDA, P. C. & GUNSOLLEY, J. N. 1996. Effects of sex hormones on protein and collagen content of the temporomandibular joint disc of the rat. *Journal of Oral and Maxillofacial Surgery*, 54, 721-727.
- ADAME, D. D., RADELL, S. A., JOHNSON, T. C. & COLE, S. P. 1991. Physical fitness, body image, and locus of control in college women dancers and nondancers. *Perceptual and Motor Skills*, 72, 91-95.
- ADAMS, K., O'SHEA, P. & O'SHEA, K. L. 1999. Aging: Its Effects on Strength, Power, Flexibility, and Bone Density. *Strength & Conditioning Journal*, 21, 65.
- AGRE, J. & BAXTER, T. 1987. Musculoskeletal profile of male collegiate soccer players. *Archives of Physical Medicine Rehabilitation Research and Practice*, 68, 147-150.
- ALBRACHT, K. & ARAMPATZIS, A. 2013. Exercise-induced changes in triceps surae tendon stiffness and muscle strength affect running economy in humans. *European Journal of Applied Physiology*, 113, 1605-1615.
- ALDABE, D., RIBEIRO, D. C., MILOSAVLJEVIC, S. & BUSSEY, M. D. 2012. Pregnancy-related pelvic girdle pain and its relationship with relaxin levels during pregnancy: a systematic review. *European Spine Journal*, 21, 1769-1776.
- ALENCAR, T. A. M. D. & MATIAS, K. F. D. S. 2010. Princípios fisiológicos do aquecimento e alongamento muscular na atividade esportiva. *Revista Brasileira de Medicina do Esporte*, 16, 230-234.
- ALRICSSON, M., HARMS-RINGDAHL, K., ERIKSSON, K. & WERNER, S. 2003. The effect of dance training on joint mobility, muscle flexibility, speed and agility in young cross-country skiers—a prospective controlled intervention study. *Scandinavian Journal of Medicine Science in Sports*, 13, 237-243.
- AMARAL, R. K. S., PACHECO, R. C. & NAVARRO, F. 2008. Nutritional and anthropometric profile of ballet practitioners/Perfil nutricional e antropometrico de praticantes de ballet. *Revista Brasileira de Nutrição Esportiva*, 2, 37-46.
- AMBEGAONKAR, J. P., SHULTZ, S. J., PERRIN, D. H., SCHMITZ, R. J., ACKERMAN, T. A. & SCHULZ, M. R. 2011. Lower body stiffness and muscle activity differences between female dancers and basketball players during drop jumps. *Sports Health*, 3, 89-96.
- ANDERSON, R. & HANRAHAN, S. J. 2008. Dancing in pain: pain appraisal and coping in dancers. *Journal of Dance Medicine & Science*, 12, 9-16.
- ANGIOI, M., METSIOS, G., KOUTEDAKIS, Y. & WYON, M. 2009a. Fitness in contemporary dance: a systematic review. *International Journal of Sports Medicine*, 30, 475-84.

- ANGIOI, M., METSIOS, G. S., TWITCHETT, E., KOUTEDAKIS, Y. & WYON, M. 2009b. Association between selected physical fitness parameters and aesthetic competence in contemporary dancers. *Journal of Dance & Medicine Science*, 13, 115-123.
- APOSTOLOPOULOS, N., METSIOS, G., FLOURIS, A., KOUTEDAKIS, Y. & WYON, M. 2015a. The relevance of stretch intensity and position—a systematic review *Front. Frontiers in Psychology*, 6, 1-25.
- APOSTOLOPOULOS, N., METSIOS, G. S., NEVILL, A., KOUTEDAKIS, Y. & WYON, M. 2015b. Stretch Intensity vs. Inflammation: A Dose-dependent Association? *International Journal of Kinesiology & Sports Science*, 3, 27-31.
- AQUINO, C. F. 2010. Análise da relação entre dor lombar e desequilíbrio de força muscular em bailarinas. *Fisioterapia e Movimento* . 23, 399-408.
- AQUINO, C. F. D., GONÇALVES, G. G. P., FONSECA, S. T. D. & MANCINI, M. C. 2006. Análise da relação entre flexibilidade e rigidez passiva dos isquiotibiais. *Revista Brasileira de Medicina no Esporte*, 12, 175-9.
- ARNDT, A., KOMI, P., BRÜGGEMANN, G. & LUKKARINIEMI, J. 1988. Individual muscle contributions to the in vivo achilles tendon force. *Clinical Biomechanics*, 13, 532-541.
- AVELA, J. & KOMI, P. V. 1998a. Interaction between muscle stiffness and stretch reflex sensitivity after long-term stretch-shortening cycle exercise. *Muscle & Nerve*, 21, 1224-1227.
- AVELA, J. & KOMI, P. V. 1998b. Reduced stretch reflex sensitivity and muscle stiffness after long-lasting stretch-shortening cycle exercise in humans. *European Journal of Applied Physiology and Occupational Physiology*, 78, 403-410.
- AVELA, J., KYRÖLÄINEN, H. & KOMI, P. V. 1999. Altered reflex sensitivity after repeated and prolonged passive muscle stretching. *Journal of Applied Physiology*, 86, 1283-1291.
- AYE, T., KURAMOTO-AHUJA, T., HAN, H. & MARUYAMA, H. 2017. Comparison of immediate effects between two medical stretching techniques on Hamstrings flexibility. *Journal of Physical Therapy Science*, 29, 1518-1521.
- AZEVEDO, D. C. & SAMULSKI, D. M. 2003. Análise de técnicas psicológicas de controle da dor: um estudo comparativo entre atletas e não-atletas. *Revista Brasileira de Medicina do Esporte*, 9, 204-13.
- BAKKER, F. C. 1988. Personality differences between young dancers and non-dancers. *Personality and Individual Differences*, 9, 121-131.
- BANAI, I. P. 2017. Voice in different phases of menstrual cycle among naturally cycling women and users of hormonal contraceptives. *Plos One*, 12, e0183462.
- BANDY, W. D. & IRION, J. M. 1994. The effect of time on static stretch on the flexibility of the hamstring muscles. *Physical Therapy*, 74, 845-850.
- BANDY, W. D., IRION, J. M. & BRIGGLER, M. 1997. The effect of time and frequency of static stretching on flexibility of the hamstring muscles. *Physical Therapy*, 77, 1090-1096.
- BASSEY, E. J. 1998. Longitudinal changes in selected physical capabilities: muscle strength, flexibility and body size. *Age and Aging*, 27, 12-16.
- BAUER, N., PIERCE, K., BARCLAY, B., DE LA FUENTE, D. & BRONNER, S. 2015. Hypermobility As A Predictor Of Injury In Preprofessional Modern Dancers. *Journal of Orthopaedic & Sports Physical*, 45, A97-A98.
- BAUMAN, J. E. 1981. Basal body temperature: unreliable method of ovulation detection. *Fertility and Sterility*, 36, 729-733.
- BÄUML, K.-H. 1989. On the relationship between the menstrual cycle and the body weight and food intake of women (Die Beziehung zwischen Monatszyklus, Körpergewicht

- und Nahrungsaufnahme (Essverhalten) bei Frauen). *Archiv für Psychologie*, 141, 237-251.
- BECKER, J. B. & HU, M. 2008. Sex differences in drug abuse. *Frontiers in Neuroendocrinology*, 29, 36-47.
- BEHM, D. G., BAMBURY, A., CAHILL, F. & POWER, K. 2004. Effect of acute static stretching on force, balance, reaction time, and movement time. *Medicine & Science in Sports & Exercise*, 36, 1397-1402.
- BELANGER, M. J., MOORE, D. C., CRISCO, J. J., FADALE, P. D., HULSTYN, M. J. & EHRLICH, M. G. 2004. Knee laxity does not vary with the menstrual cycle, before or after exercise. *The American Journal of Sports Medicine*, 32, 1150-1157.
- BELL, D., BLACKBURN, J., HACKNEY, A., MARSHALL, S., BEUTLER, A. & PADUA, D. 2014a. Jump-landing biomechanics and knee-laxity change across the menstrual cycle in women with anterior cruciate ligament reconstruction. *Journal of Athletic Training*, 49, 154-162.
- BELL, D. G. & JACOBS, I. 1986. Electro-mechanical response times and rate of force development in males and females. *Medicine and Science in Sports and Exercise*, 18, 31-36.
- BELL, D. R., BLACKBURN, J. T., HACKNEY, A. C., MARSHALL, S. W., BEUTLER, A. I. & PADUA, D. A. 2014b. Jump-landing biomechanics and knee-laxity change across the menstrual cycle in women with anterior cruciate ligament reconstruction. *Journal of Athletic Training*, 49, 154-162.
- BELL, D. R., MYRICK, M. P., BLACKBURN, J. T., SHULTZ, S. J., GUSKIEWICZ, K. M. & PADUA, D. A. 2009. The effect of menstrual-cycle phase on hamstring extensibility and muscle stiffness. *Journal of Sport Rehabilitation*, 18, 553-563.
- BENNEL, K., KHAN, K. M., MATTHEWS, B., DE GRUYTER, M., COOK, E., HOLZER, K. & WARK, J. D. 1999. Hip and ankle range of motion and hip muscle strength in young female ballet dancers and controls. *British Journal of Sports Medicine*, 33, 340-346.
- BERARDI, G. 2016. Stretching Anatomy. *Journal of Dance Medicine & Science*, 20, 46-46.
- BERTOLINI, G. R. F., BARBIERI, C. H. & MAZZER, N. 2009. Análise longitudinal de músculos sóleos, de ratos, submetidos a alongamento passivo com uso prévio de ultrassom terapêutico. *Revista Brasileira de Medicina do Esporte*, 15, 115-118.
- BIEWENER, A. & ROBERTS, T. 2000. Muscle and tendon contributions to force, work, and elastic energy savings: a comparative perspective. *Exercise and Sport Sciences Reviews*, 28, 99.
- BISHOP, D. 2003. Warm-up II: Performance changes following active warm up on exercise performance. *Sports Medicine*, 33, 483-498.
- BLACKBURN, J. T., PADUA, D. A., RIEMANN, B. L. & GUSKIEWICZ, K. M. 2004. The relationships between active extensibility, and passive and active stiffness of the knee flexors. *Journal of Electromyography and Kinesiology*, 14, 683-691.
- BLAZEVICH, A. J., CANNAVAN, D., WAUGH, C. M., FATH, F., MILLER, S. C. & KAY, A. D. 2012. Neuromuscular factors influencing the maximum stretch limit of the human plantar flexors. *Journal of Applied Physiology*, 113, 1446-1455.
- BOBBERT, M. F., GERRITSEN, K. G., LITJENS, M. C. & VAN SOEST, A. J. 1996. Why is countermovement jump height greater than squat jump height? *Medicine & Science in Sports & Exercise*, 28, 1402-1412.
- BRADLEY, P. S., OLSEN, P. D. & PORTAS, M. D. 2007. The effect of static, ballistic, and proprioceptive neuromuscular facilitation stretching on vertical jump performance. *Journal of Strength and Conditioning Research*, 21, 223.

- BRADY, C., COMYNS, T., HARRISON, A. & WARRINGTON, G. 2017. Focus of Attention for Diagnostic Testing of the Force-Velocity Curve. *Strength & Conditioning Journal*, 39, 57-70.
- BRET, C., RAHMANI, A., DUFOUR, A., MESSONNIER, L. & LACOUR, J. 2002. Leg strength and stiffness as ability factors in 100 m sprint running. *Journal of Sports Medicine and Physical Fitness*, 42, 274.
- BROOKS-GUNN, J., WARREN, M. P. & HAMILTON, L. H. 1987. The relation of eating problems and amenorrhea in ballet dancers. *Journal of Medicine Science in Sports Exercise*.
- BRUGHELLI, M. & CRONIN, J. 2008a. A review of research on the mechanical stiffness in running and jumping: methodology and implications. *Scandinavian Journal of Medicine and Science in Sports*, 18, 417-426.
- BRUGHELLI, M. & CRONIN, J. 2008b. A review of research on the mechanical stiffness in running and jumping: methodology and implications. *Scandinavian Journal of Medicine & Science in Sports*, 18, 417-426.
- BRYNHILDSEN, J., LENNARTSSON, H., KLEMETZ, M., DAHLQUIST, P., HEDIN, B. & HAMMAR, M. 1997. Oral contraceptive use among female elite athletes and age-matched controls and its relation to low back pain. *Acta Obstetrica et Gynecologica Scandinavica*, 76, 873-878.
- BURDEN, A. 2010. How should we normalize electromyograms obtained from healthy participants? What we have learned from over 25years of research. *Journal of Electromyography and Kinesiology*, 20, 1023-1035.
- BURGESS, K. E., PEARSON, S. J., BREEN, L. & ONAMBÉLÉ, G. 2009. Tendon structural and mechanical properties do not differ between genders in a healthy community-dwelling elderly population. *Journal of Orthopaedic Research*, 27, 820-825.
- BURGESS, K. E., PEARSON, S. J. & ONAMBÉLÉ, G. L. 2010. Patellar Tendon Properties With Fluctuating Menstrual Cycle Hormones. *Journal of Strength & Conditioning Research*, 24, 2088-2095.
- BURKE, D. G., CULLIGAN, C. J., HOLT, L. E. & MACKINNON, N. C. 2000. Equipment Designed to Simulate Proprioceptive Neuromuscular Facilitation Flexibility Training. *The Journal of Strength & Conditioning Research*, 14, 135-139.
- CABIDO, C. E. T., BERGAMINI, J. C., ANDRADE, A. G. P., LIMA, F., MENZEL, H. & CHAGAS, M. H. 2014. Acute effect of constant torque and angle stretching on range of motion, muscle passive properties, and stretch discomfort perception. *The Journal of Strength & Conditioning Research*, 4, 1050-1057.
- CANÇADO, G. H. D. C. P. 2014. *Efeito de 10 semanas de treinamento e destreinamento da flexibilidade com as técnicas ângulo constante e torque constante nas variáveis biomecânicas e sensoriais nos posteriores de coxa de adultos jovens*. Doutorado, Universidade Federal de Minas Gerais.
- CHAGAS, M. H., MAGALHÃES, F. A., PEIXOTO, G. H., PEREIRA, B. M., ANDRADE, A. G. & MENZEL, H.-J. K. 2016. Exploratory factor analysis for differentiating sensory and mechanical variables related to muscle-tendon unit elongation. *Brazilian Journal of Physical Therapy*, 20, 240-247.
- CHAGAS, M. H., MENZEL, H.-J., BHERING, E. L. & BERGAMINI, J. C. 2008. Comparação de duas diferentes intensidades de alongamento na amplitude de movimento. *Revista Brasileira de Medicina do Esporte*, 14, 99-103.
- CHAN, S., HONG, Y. & ROBINSON, P. 2001. Flexibility and passive resistance of the hamstrings of young adults using two different static stretching protocols. *Scandinavian Journal of Medicine Science and Sport*, 11, 81-86.

- CHANDLER, T. J., KIBLER, W. B., UHL, T. L., WOOTEN, B., KISER, A. & STONE, E. 1990. Flexibility comparisons of junior elite tennis players to other athletes. *The American Journal of Sports Medicine*, 18, 134-136.
- CHANG, G., RAJAPAKSE, C., DIAMOND, M., HONIG, S., RECHT, M., WEISS, D. & REGATTE, R. 2013. Micro-finite element analysis applied to high-resolution MRI reveals improved bone mechanical competence in the distal femur of female pre-professional dancers. *Osteoporosis International*, 24, 1407-1417.
- CHAUDHARI, A. M., LINDENFELD, T. N., ANDRIACCHI, T. P., HEWETT, T. E., RICCOBENE, J., MYER, G. D. & NOYES, F. R. 2007. Knee and hip loading patterns at different phases in the menstrual cycle. *The American Journal of Sports Medicine*, 35, 793-800.
- CICCHETTI, D. V. 1994. Guidelines, criteria, and rules of thumb for evaluating normed and standardized assessment instruments in psychology. *Psychological Assessment*, 6, 284.
- CLAUDINO, J. G., MEZÊNCIO, B., SONCIN, R., SERRÃO, J. C., AMADIO, A. C., ROSCHEL, H., BIANCO, R., TAKAO, P. P., VALADÃO, P. F. & FERREIRA, J. C. 2013. Desenvolvimento de um método de familiarização individualizado para saltos verticais. *Rev. bras. med. esporte*, 19, 359-362.
- CLAUS, A. P. & MACDONALD, D. A. 2017. Interpreting Pain Symptoms and How Pain Affects Neuromuscular Control in Dancers: If I'm in Pain, How Should I Train? *Journal of Dance Medicine & Science*, 21, 5-12.
- COGHILL, R. C., MCHAFFIE, J. G. & YEN, Y.-F. 2003. Neural correlates of interindividual differences in the subjective experience of pain. *Proceedings of the National Academy of Sciences*, 100, 8538-8542.
- COQUEIRO, R. D. S., SANTOS, M. C., NETO, J. D. S. L., QUEIROZ, B. M. D., BRÜGGER, N. A. J. & BARBOSA, A. R. 2014. Validity of a portable glucose, total cholesterol, and triglycerides multi-analyzer in adults. *Biological Research for Nursing*, 16, 288-294.
- CORDOVA, M. L. & ARMSTRONG, C. W. 1996. Reliability of ground reaction forces during a vertical jump: implications for functional strength assessment. *Journal of Athletic Training*, 31, 342.
- CORNU, C., SILVEIRA, M.-I. A. & GOUBEL, F. 1997. Influence of plyometric training on the mechanical impedance of the human ankle joint. *European Journal of Applied Physiology and Occupational Physiology*, 76, 282-288.
- COSTA, P. B., RYAN, E. D., HERDA, T. J., WALTER, A. A., HOGE, K. M. & CRAMER, J. T. 2010. Acute effects of passive stretching on the electromechanical delay and evoked twitch properties. *European Journal of Applied Physiology*, 108, 301.
- CRAIG, A. D. 2003. Pain mechanisms: labeled lines versus convergence in central processing. *Annual Review of Neuroscience*, 26, 1-30.
- CRAIG, A. D. 2009. How do you feel--now? The anterior insula and human awareness. *Nature Reviews Neuroscience*, 10.
- CREWETHER, B., KEOGH, J., CRONIN, J. & COOK, C. 2006. Possible stimuli for strength and power adaptation. *Sports Medicine*, 36, 215-238.
- CRONIN, N. J., PRILUTSKY, B. I., LICHTWARK, G. A. & MAAS, H. 2013. Does ankle joint power reflect type of muscle action of soleus and gastrocnemius during walking in cats and humans? *Journal of Biomechanics*, 46, 1383-1386.
- CRUST, L. & KEEGAN, R. 2010. Mental toughness and attitudes to risk-taking. *Personality and Individual Differences*, 49, 164-168.
- DALE, G. A. 2000. Distractions and coping strategies of elite decathletes during their most memorable performances. *The Sport Psychologist*, 14, 17-41.

- DANESHJOO, A., RAHNAMA, N., MOKHTAR, A. H. & YUSOF, A. 2013. Bilateral and unilateral asymmetries of isokinetic strength and flexibility in male young professional soccer players. *Journal of Human Kinetics*, 36, 45-53.
- DAVENPORT, K. L., AIR, M., GRIERSON, M. J. & KRABAK, B. J. 2016. Examination of static and dynamic core strength and rates of reported dance related injury in collegiate dancers: a cross-sectional study. *Journal of Dance Medicine & Science*, 20, 151-161.
- DAVIS, D. S., ASHBY, P. E., MCCAULE, K. L., MCQUAIN, J. A. & WINE, J. M. 2005. The effectiveness of 3 stretching techniques on hamstring flexibility using consistent stretching parameters. *Journal of Strength and Conditioning Research*, 19, 27.
- DE ALBUQUERQUE, C. V., MASCHIO, J. P., GRUBER, C. R., DE SOUZA, R. M. & HERNANDEZ, S. 2011. Efeito agudo de diferentes formas de aquecimento sobre a força muscular. *Fisioterapia em Movimento*, 24.
- DE WEIJER, V. C., GORNIK, G. C. & SHAMUS, E. 2003. The effect of static stretch and warm-up exercise on hamstring length over the course of 24 hours. *Journal of Orthopaedic & Sports Physical Therapy*, 33, 727-733.
- DECOSTER, L. C., BERNIER, J. N., LINDSAY, R. H. & VAILAS, J. C. 1999. Generalized joint hypermobility and its relationship to injury patterns among NCAA lacrosse players. *Journal of athletic training*, 34, 99.
- DECOSTER, L. C., CLELAND, J., ALTIERI, C. & RUSSELL, P. 2005. The effects of hamstring stretching on range of motion: a systematic literature review. *Journal of Orthopaedic & Sports Physical Therapy*, 35, 377-387.
- DEDRICK, G. S., SIZER, P. S., MERKLE, J. N., HOUNSHELL, T. R., ROBERT-MCCOMB, J. J., SAWYER, S. F., BRISMÉE, J.-M. & JAMES, C. R. 2008. Effect of sex hormones on neuromuscular control patterns during landing. *Journal of Electromyography and Kinesiology*, 18, 68-78.
- DEIE, M., SAKAMAKI, Y., SUMEN, Y., URABE, Y. & IKUTA, Y. 2002. Anterior knee laxity in young women varies with their menstrual cycle. *International Orthopaedics*, 26, 154-156.
- DEROCHE, T., WOODMAN, T., STEPHAN, Y., BREWER, B. W. & LE SCANFF, C. 2011. Athletes' inclination to play through pain: a coping perspective. *Anxiety, Stress & Coping*, 24, 579-587.
- DI ALENCAR, T. A. M. & MATIAS, K. F. D. S. 2010. Princípios fisiológicos do aquecimento e alongamento muscular na atividade esportiva. *Rev Bras Med Esporte*, 16, 230-4.
- DOYLE-LUCAS, A. F., AKERS, J. D. & DAVY, B. M. 2010. Energetic efficiency, menstrual irregularity, and bone mineral density in elite professional female ballet dancers. *Journal of Dance Medicine & Science*, 14, 146-154.
- DRAGOO, J. L., CASTILLO, T. N., BRAUN, H. J., RIDLEY, B. A., KENNEDY, A. C. & GOLISH, S. R. 2011. Prospective correlation between serum relaxin concentration and anterior cruciate ligament tears among elite collegiate female athletes. *The American Journal of Sports Medicine*, 39, 2175-2180.
- DRAHOVZAL, D. N., STEWART, S. H. & SULLIVAN, M. J. 2006. Tendency to catastrophize somatic sensations: Pain catastrophizing and anxiety sensitivity in predicting headache. *Cognitive Behaviour Therapy*, 35, 226-235.
- EDWARDS, R., HARRIS, R., HULTMAN, E., KAIJSER, L., KOH, D. & NORDESJÖ, L. 1972. Effect of temperature on muscle energy metabolism and endurance during successive isometric contractions, sustained to fatigue, of the quadriceps muscle in man. *The Journal of Physiology*, 220, 335-352.
- EDWARDS, R. R. 2005. Individual differences in endogenous pain modulation as a risk factor for chronic pain. *Neurology*, 65, 437-443.

- EILING, E., BRYANT, A., PETERSEN, W., MURPHY, A. & HOHMANN, E. 2007. Effects of menstrual-cycle hormone fluctuations on musculotendinous stiffness and knee joint laxity. *Knee Surgery Sports Traumatology Arthroscopy*, 15, 126-132.
- ELORANTA, V. 1997. Effect of postural and load variation on the coordination of the leg muscles in rebound jumping movement. *Electromyography and clinical neurophysiology*, 37, 79-88.
- ELORANTA, V. 2003. Influence of sports background on leg muscle coordination in vertical jumps. *Electromyography and clinical neurophysiology*, 43, 141-156.
- ESTON, R. G., ROWLANDS, A. V., COULTON, D., MCKINNEY, J. & GLEESON, N. P. 2007. Effect of flexibility training on symptoms of exercise-induced muscle damage: a preliminary study. *J Exerc Sci Fit*, 5, 33-9.
- ETTEMA, G. 1996. Mechanical efficiency and efficiency of storage and release of series elastic energy in skeletal muscle during stretch-shorten cycles. *Journal of Experimental Biology*, 199, 1983-1997.
- ETTEMA, G. 2001. Muscle efficiency: the controversial role of elasticity and mechanical energy conversion in stretch-shortening cycles. *European Journal of Applied Physiology*, 85, 457-465.
- FARLEY, C. T., BLICKHAN, R., SAITO, J. & TAYLOR, C. R. 1991. Hopping frequency in humans: a test of how springs set stride frequency in bouncing gaits. *Journal of Applied Physiology*, 71, 2127-2132.
- FARYNIARZ, D. A., BHARGAVA, M., LAJAM, C., ATTIA, E. T. & HANNAFIN, J. A. 2006. Quantitation of estrogen receptors and relaxin binding in human anterior cruciate ligament fibroblasts. *In Vitro Cellular & Developmental Biology-Animal*, 42, 176-181.
- FASEN, J. M., O'CONNOR, A. M., SCHWARTZ, S. L., WATSON, J. O., PLASTARAS, C. T., GARVAN, C. W., BULCAO, C., JOHNSON, S. C. & AKUTHOTA, V. 2009. A randomized controlled trial of hamstring stretching: comparison of four techniques. *The Journal of Strength Conditioning Research*, 23, 660-667.
- FEHRING, R., SCHEIDER, M. & RAVIELE, K. 2006. Variability in the phases of the menstrual cycle. *Journal of Obstetric, Gynecologic & Neonatal Nursing*, 35, 376-384.
- FELAND, J. B., MYRER, J. W. & MERRIL, R. M. 2001. Acute changes in hamstring exibility: PNF versus static stretch in senior athletes. *Journal of Physical Therapy*, 2, 33-44.
- FERRY, B., DUCLOS, M., BURT, L., THERRE, P., LE GALL, F., JAFFRÉ, C. & COURTEIX, D. 2011. Bone geometry and strength adaptations to physical constraints inherent in different sports: comparison between elite female soccer players and swimmers. *Journal of Bone and Mineral Metabolism*, 29, 342-351.
- FLOOD, A., WADDINGTON, G., THOMPSON, K. & CATHCART, S. 2017. Increased conditioned pain modulation in athletes. *Journal of Sports Sciences*, 35, 1066-1072.
- FOURÉ, A., NORDEZ, A. & CORNU, C. 2012. Effects of plyometric training on passive stiffness of gastrocnemii muscles and Achilles tendon. *European Journal of Applied Physiology*, 112, 2849-2857.
- FOURÉ, A., NORDEZ, A., MCNAIR, P. & CORNU, C. 2011. Effects of plyometric training on both active and passive parts of the plantarflexors series elastic component stiffness of muscle-tendon complex. *European Journal of Applied Physiology*, 111, 539-548.
- FOWLES, J., SALE, D. & MACDOUGALL, J. 2000. Reduced strength after passive stretch of the human plantarflexors. *Journal of Applied Physiology*, 89, 1179-1188.
- FRADKIN, A. J., GABBE, B. J. & CAMERON, P. A. 2006. Does warming up prevent injury in sport?: The evidence from randomised controlled trials? *Journal of Science and Medicine in Sport*, 9, 214-220.

- FRANCE, C. R., FRANCE, J. L., AL'ABSI, M., RING, C. & MCINTYRE, D. 2002. Catastrophizing is related to pain ratings, but not nociceptive flexion reflex threshold. *Pain*, 99, 459-463.
- FRANCHI, M. V., LONGO, S., MALLINSON, J., QUINLAN, J. I., TAYLOR, T., GREENHAFF, P. L. & NARICI, M. V. 2017. Muscle thickness correlates to muscle cross sectional area in the assessment of strength training induced hypertrophy. *Scandinavian Journal of Medicine & Science in Sports*.
- FRANKOVICH, R. J. & LEBRUN, C. M. 2000. Menstrual cycle, contraception, and performance. *Clinics in Sports Medicine*, 19, 251-271.
- FRASSON, V. B., DIEFENTHAELER, F. & VAZ, M. A. 2009. Comparative study of anthropometric variables in female classical ballet dancers, volleyball players and physically active subjects. *Brazilian Journal of Kinanthropometry Human Performance*, 11, 8-13.
- FREITAS, S. R., VILARINHO, D., VAZ, J. R., BRUNO, P. M., COSTA, P. B. & MIL-HOMENS, P. 2015. Responses to static stretching are dependent on stretch intensity and duration. *Clinical Physiology and Functional Imaging*, 35, 478-484.
- FRIDEN, C., SAARTOK, T., BÄCKSTRÖM, C., LEANDERSON, J. & RENSTRÖM, P. 2003. The influence of premenstrual symptoms on postural balance and kinesthesia during the menstrual cycle. *Gynecological Endocrinology*, 17, 433-440.
- FRISCH, R. E., WYSHAK, G. & VINCENT, L. 1980. Delayed menarche and amenorrhea in ballet dancers. *New England Journal of Medicine*, 303, 17-19.
- GAJDOSIK, R. L. 2001. Passive extensibility of skeletal muscle: review of the literature with clinical implications. *Clinical Biomechanics*, 16, 87-101.
- GAJDOSIK, R. L., LEVEAU, B. F. & BOHANNON, R. W. 1985. Effects of ankle dorsiflexion on active and passive unilateral straight leg raising. *Physical Therapy*, 65, 1478-1482.
- GAJDOSIK, R. L., VANDER LINDEN, D. W. & WILLIAMS, A. K. 1999. Influence of age on length and passive elastic stiffness characteristics of the calf muscle-tendon unit of women. *Physical Therapy*, 79, 827-838.
- GANNON, L. & BIRD, H. 1999. The quantification of joint laxity in dancers and gymnasts. *Journal of Sports Sciences*, 17, 743-750.
- GEERTSEN, S. S., KJÆR, M., PEDERSEN, K. K., PETERSEN, T. H., PEREZ, M. A. & NIELSEN, J. B. 2013. Central common drive to antagonistic ankle muscles in relation to short-term cocontraction training in nondancers and professional ballet dancers. *Journal of Applied Physiology*, 115, 1075-1081.
- GOEKEN, L. & HOF, L. 1994. Instrumental straight-leg raising: results in patients. *Archives of Physical Medicine and Rehabilitation*, 75, 470-477.
- GOLDSMITH, L. T. & WEISS, G. 2009. Relaxin in human pregnancy. *Relaxin And Related Peptides: Fifth International Conference*. New York: Annals of the New York Academy of Sciences.
- GOLDSPINK, G. & HARRIDGE, S. 1992. Cellular and molecular aspects of adaptation in skeletal muscle. *Strength and Power in Sport*, 3, 231-51.
- GRACELY, R. 2006. Studies of pain in human subjects. *Wall and Melzack's textbook of pain*, 267-284.
- GREGO, L. G., MONTEIRO, H. L., PADOVANI, C. R. & GONÇALVES, A. 1999. Lesões na dança: estudo transversal híbrido em academias da cidade de Bauru-SP. *Revista Brasileira de Medicina do Esporte*, 13.

- GROSSET, J., PISCIONE, J., LAMBERTZ, D. & PÉROT, C. 2009. Paired changes in electromechanical delay and musculotendinous stiffness after endurance or plyometric training. *European Journal of Applied Physiology*, 105, 131-139.
- GUPTA, A., FERNIHOUGH, B., BAILEY, G., BOMBECK, P., CLARKE, A. & HOPPER, D. 2004. An evaluation of differences in hip external rotation strength and range of motion between female dancers and non-dancers *British Journal of Sports Medicine*, 38, 778-783.
- HALAKI, M. & GINN, K. 2012. Normalization of EMG signals: to normalize or not to normalize and what to normalize to? *Computational intelligence in electromyography analysis-a perspective on current applications and future challenges*. InTech.
- HALBERTSMA, J. P. & GÖEKEN, L. N. 1994. Stretching exercises: effect on passive extensibility and stiffness in short hamstrings of healthy subjects. *Archives of Physical Medicine and Rehabilitation*, 75, 976-981.
- HALBERTSMA, J. P., VAN BOLHUIS, A. I. & GÖEKEN, L. N. 1996. Sport stretching: effect on passive muscle stiffness of short hamstrings. *Archives of Physical Medicine and Rehabilitation*, 77, 688-692.
- HALL, S. J. 1995. *Basic biomechanics*, McGraw-Hill Humanities, Social Sciences & World Languages.
- HAMILTON, W. G., HAMILTON, L. H., MARSHALL, P. & MOLNAR, M. 1992. A profile of the musculoskeletal characteristics of elite professional ballet dancers. *The American journal of sports medicine*, 20, 267-273.
- HANSEN, M., COUPPE, C., HANSEN, C. S., SKOVGAARD, D., KOVANEN, V., LARSEN, J. O., AAGAARD, P., MAGNUSSON, S. P. & KJAER, M. 2013. Impact of oral contraceptive use and menstrual phases on patellar tendon morphology, biochemical composition, and biomechanical properties in female athletes. *Journal of Applied Physiology*, 114, 998-1008.
- HANSEN, M., KONGSGAARD, M., HOLM, L., SKOVGAARD, D., MAGNUSSON, S. P., QVORTRUP, K., LARSEN, J. O., AAGAARD, P., DAHL, M. & SERUP, A. 2009a. Effect of estrogen on tendon collagen synthesis, tendon structural characteristics, and biomechanical properties in postmenopausal women. *Journal of Applied Physiology*, 106, 1385-1393.
- HANSEN, M., MILLER, B. F., HOLM, L., DOESSING, S., PETERSEN, S. G., SKOVGAARD, D., FRYSTYK, J., FLYVBJERG, A., KOSKINEN, S. & PINGEL, J. 2009b. Effect of administration of oral contraceptives in vivo on collagen synthesis in tendon and muscle connective tissue in young women. *Journal of Applied Physiology*, 106, 1435-1443.
- HARLEY, Y. 2002. Quadriceps Strength and Jumping Efficiency in Dancers. *Journal of Dance and Medicine Science*, 6, 87-94.
- HARLEY, Y. X., GIBSON, A. S. C., HARLEY, E. H., LAMBERT, M. I., VAUGHAN, C. L. & NOAKES, T. D. 2002. Quadriceps strength and jumping efficiency in dancers. *Journal of Dance Medicine & Science*, 6, 87-94.
- HARLOW, S. D. & EPHROSS, S. A. 1995. Epidemiology of menstruation and its relevance to womens health. *Epidemiologic Reviews*, 17, 265-86.
- HARVEY, D. 1998. Assessment of the flexibility of elite athletes using the modified Thomas test. *British Journal of Sports Medicine*, 32, 68-70.
- HEITZ, N. A., EISENMAN, P. A., BECK, C. L. & WALKER, J. A. 1999. Hormonal changes throughout the menstrual cycle and increased anterior cruciate ligament laxity in females. *Journal of Athletic Training*, 34, 144.

- HENNEFER, D. & LAESON, E. 2009. Pharmacology- a systems approach: female hormones. *British Journal of Healthcare Assistants*, 3, 498-501.
- HERDA, T., COSTA, P., WALTER, A., RYAN, E. & CRAMER, J. 2014. The time course of the effects of constant-angle and constant-torque stretching on the muscle–tendon unit. *Scandinavian Journal of Medicine & Science in Sports*, 24, 62-67.
- HERDA, T., RYAN, E., COSTA, P., WALTER, A., HOGE, K., URIBE, B., MCLAGAN, J., STOUT, J. & CRAMER, J. T. 2010a. 4 Acute effects of passive stretching and vibration on the electromechanical delay and musculotendinous stiffness of the plantar flexors. *Electromyography & Clinical Neurophysiology*, 50, 277.
- HERDA, T. J., COSTA, P. B., WALTER, A. A., RYAN, E. D., HOGE, K. M., KERKSICK, C. M., STOUT, J. R. & CRAMER, J. T. 2011a. Effects of two modes of static stretching on muscle strength and stiffness. *Medicine & Science in Sports & Exercise*, 43, 1777-1784.
- HERDA, T. J., CRAMER, J. T., RYAN, E. D., MCHUGH, M. P. & STOUT, J. R. 2008. Acute effects of static versus dynamic stretching on isometric peak torque, electromyography, and mechanomyography of the biceps femoris muscle. *The Journal of Strength & Conditioning Research*, 22, 809-817.
- HERDA, T. J., HOUSH, T. J., FRY, A. C., WEIR, J. P., SCHILLING, B. K., RYAN, E. D. & CRAMER, J. T. 2010b. A noninvasive, log-transform method for fiber type discrimination using mechanomyography. *Journal of Electromyography and Kinesiology*, 20, 787-794.
- HERDA, T. J., WALTER, A. A., COSTA, P. B., RYAN, E. D., STOUT, J. R. & CRAMER, J. T. 2011b. Differences in the log-transformed electromyographic–force relationships of the plantar flexors between high-and moderate-activated subjects. *Journal of Electromyography and Kinesiology*, 21, 841-846.
- HERDA, T. J., WEIR, J. P., RYAN, E. D., WALTER, A. A., COSTA, P. B., HOGE, K. M., BECK, T. W., STOUT, J. R. & CRAMER, J. T. 2009. Reliability of absolute versus log-transformed regression models for examining the torque-related patterns of response for mechanomyographic amplitude. *Journal of Neuroscience Methods*, 179, 240-246.
- HERZOG, W., NIGG, B. M., READ, L. J. & OLSSON, E. 1989. Asymmetries in ground reaction force patterns in normal human gait. *Medicine & Science in Sports & Exercise*, 21, 110-114.
- HEWETT, T. E., ZAZULAK, B. T. & MYER, G. D. 2007. Effects of the menstrual cycle on anterior cruciate ligament injury risk. *The American Journal of Sports Medicine*, 35, 659-668.
- HICKS, K. M., ONAMBELE-PEARSON, G. L., WINWOOD, K. & MORSE, C. I. 2013. Gender differences in fascicular lengthening during eccentric contractions: the role of the patella tendon stiffness. *Acta Physiologica*, 209, 235-244.
- HILL, A. 1938. The heat of shortening and the dynamic constants of muscle. *Proceedings of the Royal Society of London B: Biological Sciences*, 126, 136-195.
- HOGE, K., RYAN, E., COSTA, P. & CRAMER, J. 2010. Gender differences in musculotendinous stiffness and range of motion after an acute bout of stretching. *The Journal of Strength & Conditioning Research*, 24, 523-533.
- HOPKINS, D. R., MURRAH, B., HOEGER, W. W. & RHODES, R. C. 1990. Effect of low-impact aerobic dance on the functional fitness of elderly women. *The Gerontological Society of America*, 30, 189-192.
- HORVATH, S. M. & DRINKWATER, B. L. 1982. Thermoregulation and the menstrual cycle. *Aviation, Space, Environmental Medicine*, 53, 790-794.
- HUI, E., CHUI, B. T.-K. & WOO, J. 2009. Effects of dance on physical and psychological well-being in older persons. *Archives of Gerontology and Geriatrics*, 49, e45-e50.

- HUSTON, L. J. & WOJTYS, E. M. 1996. Neuromuscular performance characteristics in elite female athletes. *The American Journal of Sports Medicine*, 24, 427-436.
- HUTTON, R. 1992. Neuromuscular basis of stretching exercises. *Strength and Power in Sport*, 3, 29-38.
- IMPELLIZZERI, F. M., RAMPININI, E., MAFFIULETTI, N. & MARCORÀ, S. M. 2007. A vertical jump force test for assessing bilateral strength asymmetry in athletes. *Medicine & Science in Sports & Exercise*, 39, 2044-2050.
- INDO, Y. 2014. Neurobiology of pain, interoception and emotional response: lessons from nerve growth factor-dependent neurons. *European Journal of Neuroscience*, 39, 375-391.
- ISHIDA, Y., KANEHISA, H., CARROLL, J. F., POLLOCK, M. L., GRAVES, J. E. & LEGGETT, S. H. 1995. Body fat and muscle thickness distributions in untrained young females. *Medicine Science in Sports Exercise*, 27, 270-274.
- ISSURIN, V. & TENENBAUM, G. 1999. Acute and residual effects of vibratory stimulation on explosive strength in elite and amateur athletes. *Journal of sports sciences*, 17, 177-182.
- JANYACHAROEN, T., LAOPHOSRI, M., KANPITTAYA, J., AUVICHAYAPAT, P. & SAWANYAWISUTH, K. 2013. Physical performance in recently aged adults after 6 weeks traditional Thai dance: a randomized controlled trial. *Clinical Interventions in Aging*, 8, 855.
- JANZ, K. F., DAWSON, J. D. & MAHONEY, L. T. 2000. Predicting heart growth during puberty: The Muscatine Study. *Pediatrics*, 105, e63-e63.
- JENSEN, R. L. & EBBEN, W. P. 2003. Kinetic analysis of complex training rest interval effect on vertical jump performance. *The Journal of Strength & Conditioning Research*, 17, 345-349.
- JESSELL, T. & KJELLY, D. 2003. Percepção e dor. *Princípios da Neurociência*. Barueri: Manole.
- JOHNSON, M., STEWART, J., HUMPHRIES, S. & CHAMOVE, A. 2012. Marathon runners' reaction to potassium iontophoretic experimental pain: Pain tolerance, pain threshold, coping and self-efficacy. *European Journal of Pain*, 16, 767-774.
- JUKIC, A. M. Z., WEINBERG, C. R., WILCOX, A. J., MCCONNAUGHEY, D. R., HORNSBY, P. & BAIRD, D. D. 2007. Accuracy of reporting of menstrual cycle length. *American Journal of Epidemiology*, 167, 25-33.
- JURKOWSKI, J. E., JONES, N. L., WALKER, C., YOUNGLAI, E. V. & SUTTON, J. R. 1978. Ovarian hormonal responses to exercise. *Journal of Applied Physiology*, 44, 109-114.
- KADEL, N. J., DONALDSON-FLETCHER, E. A., GERBERG, L. F. & MICHELI, L. 2005. Anthropometric measurements of young ballet dancers examining body composition, puberty, flexibility, and joint range of motion in comparison with non-dancer controls. *Journal of Dance Medicine & Science*, 9, 84-90.
- KAMPING, S., ANDOH, J., BOMBA, I. C., DIERS, M., DIESCH, E. & FLOR, H. 2016. Contextual modulation of pain in masochists: involvement of the parietal operculum and insula. *Pain*, 157, 445.
- KANEHISA, H., IKEGAWA, S. & FUKUNAGA, T. 1994. Comparison of muscle cross-sectional area and strength between untrained women and men. *European Journal of Applied Physiology and Occupational Physiology*, 68, 148-154.
- KARAGEANES, S. J., BLACKBURN, K. & VANGELOS, Z. A. 2000. The association of the menstrual cycle with the laxity of the anterior cruciate ligament in adolescent female athletes. *Clinical Journal of Sport Medicine*, 10, 162-168.

- KARASUNO, H., OGIHARA, H., MORISHITA, K., YOKOI, Y., FUJIWARA, T., OGOMA, Y. & ABE, K. 2016. The combined effects of transcutaneous electrical nerve stimulation (TENS) and stretching on muscle hardness and pressure pain threshold. *Journal of Physical Therapy Science*, 28, 1124-1130.
- KARLOH, M., SANTOS, R. P. D., KRAESKI, M. H., MATIAS, T. S., KRAESKI, D. & MENEZES, F. S. D. 2010. Alongamento estático versus conceito Mulligan: aplicações no treino de flexibilidade em ginastas. *Revista Fisioterapia em Movimento*, 24, 523-533.
- KATO, E., KANEHISA, H., FUKUNAGA, T. & KAWAKAMI, Y. 2010. Changes in ankle joint stiffness due to stretching: The role of tendon elongation of the gastrocnemius muscle. *European Journal of Sport Science*, 10, 111-119.
- KAWAKAMI, Y., MURAOKA, T., ITO, S., KANEHISA, H. & FUKUNAGA, T. 2002. In vivo muscle fibre behaviour during counter-movement exercise in humans reveals a significant role for tendon elasticity. *The Journal of Physiology*, 540, 635-646.
- KAY, A. D. & BLAZEVIICH, A. J. 2010. Concentric muscle contractions before static stretching minimize, but do not remove, stretch-induced force deficits. *Journal of Applied Physiology*, 108, 637-645.
- KEIZER, H. A. & ROGOL, A. D. 1990. Physical exercise and menstrual cycle alterations. *Sports Medicine*, 10, 218-235.
- KENT, M. 2006. *The Oxford Dictionary of Sports Science & Medicine* Oxford, Oxford University Press.
- KHAN, H. & STROMAN, P. 2015. Inter-individual differences in pain processing investigated by functional magnetic resonance imaging of the brainstem and spinal cord. *Neuroscience*, 307, 231-241.
- KIMMERLE, M. J. J. O. D. M. & SCIENCE 2010. Lateral bias, functional asymmetry, dance training and dance injuries. 14, 58-66.
- KLEMP, P., STEVENS, J. & ISAACS, S. 1984. A hypermobility study in ballet dancers. *The Journal of Rheumatology*, 11, 692-696.
- KNAPIK, J. J., BAUMAN, C. L., JONES, B. H., HARRIS, J. M. & VAUGHAN, L. 1991. Preseason strength and flexibility imbalances associated with athletic injuries in female collegiate athletes. *The American Journal of Sports Medicine*, 19, 76-81.
- KNIGHT, K. L. & DRAPER, D. O. 2012. *Therapeutic modalities: the art and science*, Lippincott Williams & Wilkins.
- KNUDSON, D., BENNETT, K., CORN, R., LEICK, D. & SMITH, C. 2001. Acute effects of stretching are not evident in the kinematics of the vertical jump. *The Journal of Strength Conditioning Research*, 15, 98-101.
- KOCEJA, D., BURKE, J. & KAMEN, G. 1991. Organization of segmental reflexes in trained dancers. *International Journal of Sports Medicine*, 12, 285-289.
- KOMI, P., HORITA, T., KYRÖLÄINEN, H., TAKALA, T. & NICOL, C. 1996. Reduced stretch-reflex sensitivity after exhausting stretch-shortening cycle exercise. *European Journal of Applied Physiology and Occupational Physiology*, 72, 401-409.
- KOMI, P. V. 1992. *Strength and power in sport*, Blackwell scientific publications Oxford.
- KOUTEDAKIS, Y., HUKAM, H., METSIOS, G. & NEVILL, A. 2007. The effects of three months of aerobic and strength training on selected performance-and fitness-related parameters in modern dance students. *Journal of Strength and Conditioning Research*, 21, 808.
- KOUTEDAKIS, Y., STAVROPOULOS-KALINOGLU, A. & METSIOS, G. 2005. The significance of muscular strength in dance. *Journal of dance medicine & science*, 9, 29-34.

- KOWALCZYK, W. J., EVANS, S. M., BISAGA, A. M., SULLIVAN, M. A. & COMER, S. D. 2006. Sex differences and hormonal influences on response to cold pressor pain in humans. *The Journal of Pain*, 7, 151-160.
- KRAMER, L., DENEGAR, C., BUCKLEY, W. & HERTEL, J. 2007. Factors associated with anterior cruciate ligament injury: history in female athletes. *Journal of Sports Medicine and Physical Fitness*, 47, 446.
- KUBO, K., KANEHISA, H. & FUKUNAGA, T. 2001a. Is passive stiffness in human muscles related to the elasticity of tendon structures? *European Journal of Applied Physiology*, 85, 226-232.
- KUBO, K., KANEHISA, H. & FUKUNAGA, T. 2002. Effects of resistance and stretching training programmes on the viscoelastic properties of human tendon structures in vivo. *The Journal of Physiology*, 538, 219-226.
- KUBO, K., KANEHISA, H., KAWAKAMI, Y. & FUKUNAGA, T. 2001b. Influence of static stretching on viscoelastic properties of human tendon structures in vivo. *Journal of Applied Physiology*, 90, 520-527.
- LABUS, J. S., NALIBOFF, B., KILPATRICK, L., LIU, C., ASHE-MCNALLEY, C., DOS SANTOS, I. R., ALAVERDYAN, M., WOODWORTH, D., GUPTA, A. & ELLINGSON, B. M. 2016. Pain and Interoception Imaging Network (PAIN): A multimodal, multisite, brain-imaging repository for chronic somatic and visceral pain disorders. *Neuroimage*, 124, 1232-1237.
- LAROCHE, D. P. & CONNOLLY, D. A. 2006. Effects of stretching on passive muscle tension and response to eccentric exercise. *The American Journal of Sports Medicine*, 34, 1000-1007.
- LATASH, M. L. & ZATSIORSKY, V. 2015. *Biomechanics and motor control: defining central concepts*, Academic Press.
- LAUDNER, K. G., BENJAMIN, P. J. & SELKOW, N. M. 2016. Effect of Ankle Positioning During Hamstring Stretches for Improving Straight Leg Hip Flexion Motion. *Clinical Journal of Sport Medicine*, 26, 167-171.
- LEBRUN, C. M., MCKENZIE, D., PRIOR, J. C. & TAUNTON, J. E. 1995. Effects of menstrual cycle phase on athletic performance. *Journal of Medicine Science in Sports Exercise*, 27, 437-444.
- LEE, H., HA, H., HAHN, J., LIM, S. & LEE, W. 2018. Intra- and inter-rater reliabilities for novel muscle thickness assessment during Co-contraction with dual-rehabilitative ultrasound imaging. *Physical Therapy in Sports*, 32, 109-114.
- LEES, A., VANRENTERGHEM, J. & DE CLERCQ, D. 2004. Understanding how an arm swing enhances performance in the vertical jump. *Journal of Biomechanics*, 37, 1929-1940.
- LEVY, A. R., POLMAN, R. C., CLOUGH, P. J., MARCHANT, D. C. & EARLE, K. 2006. Mental toughness as a determinant of beliefs, pain, and adherence in sport injury rehabilitation. *Journal of Sport Rehabilitation*, 15, 245-254.
- LIEDERBACH, M., KREMENIC, I. J., ORISHIMO, K. F., PAPPAS, E. & HAGINS, M. 2014. Comparison of landing biomechanics between male and female dancers and athletes, part 2: influence of fatigue and implications for anterior cruciate ligament injury. *The American Journal of Sports Medicine*, 42, 1089-1095.
- LIMA, C. D., BROWN, L. E., PINTO, R. S., RUAS, C. V., WONG, M. A. & LEYVA, W. D. 2016. Acute Effects of Static vs. Ballistic Stretching on Strength Between Ballet Dancers and Resistance Trained Women. *Medicine & Science in Sports & Exercise*, 48, 935.

- LIMITED, V. M. S. 2010. *Plug-in Gait Product Guide—Foundation Notes* [Online]. <http://www.vicon.com>: OMG Plc company. Available: <http://www.vicon.com> [Accessed August 2018].
- LIN, C.-W., SU, F.-C., WU, H.-W. & LIN, C.-F. 2013. Effects of leg dominance on performance of ballet turns (pirouettes) by experienced and novice dancers. *Journal of Sports Sciences*, 31, 1781-1788.
- LINTHORNE, N. P. 2001. Analysis of standing vertical jumps using a force platform. *American Journal of Physics*, 69, 1198-1204.
- LIU, S. H., AL-SHAikh, R., PANOSSIAN, V., YANG, R. S., NELSON, S. D., SOLEIMAN, N., FINERMAN, G. A. & LANE, J. M. 1996. Primary immunolocalization of estrogen and progesterone target cells in the human anterior cruciate ligament. *Journal of Orthopaedic Research*, 14, 526-533.
- LOPES, C. R., AOKI, M. S., CRISP, A. H., DE MATTOS, R. S., LINS, M. A., DA MOTA, G. R., SCHOENFELD, B. J. & MARCHETTI, P. H. 2017. The Effect of Different Resistance Training Load Schemes on Strength and Body Composition in Trained Men. *Journal of Human Kinetics*, 58, 177-186.
- MACIEL, A. & CÂMARA, S. 2008. Influência da estimulação elétrica nervosa transcutânea (TENS) associada ao alongamento muscular no ganho de flexibilidade. *Revista Brasileira de Fisioterapia*, 12.
- MAGANARIS, C. N. 2001. Force-length characteristics of in vivo human skeletal muscle. *Acta Physiologica Scandinavica*, 172, 279-285.
- MAGANARIS, C. N. & PAUL, J. P. 2002. Tensile properties of the in vivo human gastrocnemius tendon. *Journal of Biomechanics*, 35, 1639-1646.
- MAGEE, D. J., ZACHAZEWSKI, J. E. & QUILLEN, W. S. 2007. *Scientific Foundations and Principles of Practice in Musculoskeletal Rehabilitation*, Elsevier Health Sciences.
- MAGNUSSON, P. & RENSTRÖM, P. 2006. The European College of Sports Sciences Position statement: The role of stretching exercises in sports. *European Journal of Sport Science*, 6, 87-91.
- MAGNUSSON, S. P. 1998. Passive properties of human skeletal muscle during stretch maneuvers. *Scandinavian Journal of Medicine & Science in Sports*, 8, 65-77.
- MAGNUSSON, S. P., AAGAARD, P. & NIELSON, J. J. 2000. Passive energy return after repeated stretches of the hamstring muscle-tendon unit. *Medicine and Science in Sports and Exercise*, 32, 1160-1164.
- MAGNUSSON, S. P., HANSEN, M., LANGBERG, H., MILLER, B., HARALDSSON, B., KJOELLER WESTH, E., KOSKINEN, S., AAGAARD, P. & KJÆR, M. 2007. The adaptability of tendon to loading differs in men and women. *International Journal of Experimental Pathology*, 88, 237-240.
- MAGNUSSON, S. P., SIMONSEN, E., AAGAARD, P., SØRENSEN, H. & KJAER, M. 1996a. A mechanism for altered flexibility in human skeletal muscle. *The Journal of Physiology*, 497, 291-298.
- MAGNUSSON, S. P., SIMONSEN, E. B., AAGAARD, P., BOESEN, J., JOHANNSEN, F. & KJAER, M. 1997. Determinants of musculoskeletal flexibility: viscoelastic properties, cross-sectional area, EMG and stretch tolerance. *Scandinavian Journal of Medicine & Science in Sports*, 7, 195-202.
- MAGNUSSON, S. P., SIMONSEN, E. B., AAGAARD, P., DYHRE-POULSEN, P., MCHUGH, M. P. & KJAER, M. 1996b. Mechanical and physiological responses to stretching with and without preisometric contraction in human skeletal muscle. *Archives of Physical Medicine and Rehabilitation*, 77, 373-378.

- MAHIEU, N. N., MCNAIR, P., COOLS, A., D'HAEN, C., VANDERMEULEN, K. & WITVROUW, E. 2008. Effect of eccentric training on the plantar flexor muscle-tendon tissue properties. *Medicine and Science in Sports and Exercise*, 40, 117-123.
- MARGINSON, V. & ESTON, R. 2001. The relationship between torque and joint angle during knee extension in boys and men. *Journal of Sports Sciences*, 19, 875-880.
- MARGINSON, V., ROWLANDS, A. V., GLEESON, N. P. & ESTON, R. G. 2005. Comparison of the symptoms of exercise-induced muscle damage after an initial and repeated bout of plyometric exercise in men and boys. *Journal of Applied Physiology*, 99, 1174-1181.
- MARKOVIC, G., DIZDAR, D., JUKIC, I. & CARDINALE, M. 2004. Reliability and factorial validity of squat and countermovement jump tests. *The Journal of Strength & Conditioning Research*, 18, 551-555.
- MARSHALL, J. 1963. Thermal changes in the normal menstrual cycle. *British Medical Journal*, 1, 102.
- MARSHALL, P. W., CASHMAN, A. & CHEEMA, B. S. 2011. A randomized controlled trial for the effect of passive stretching on measures of hamstring extensibility, passive stiffness, strength, and stretch tolerance. *Journal of Science and Medicine in Sport*, 14, 535-540.
- MAYER, E., NALIBOFF, B., KILPATRICK, L., LABUS, J., LIU, C., ASHE-MCNALLY, C., DOS SANTOS, I. & TILLISCH, K. 2015. The pain and interoception imaging network (PAIN) repository: towards big data approaches to chronic pain. *The Journal of Pain*, 16, S52.
- MCCONNEELL, A. & OCEANSIDE, C. 2013. Pilates Training and Rehabilitation for Professional Ballet Dancers.
- MCCRACKEN, L. M. 2013. Pain Anxiety Symptoms Scale (PASS) and short version PASS-20. *Encyclopedia of Behavioral Medicine*. Springer.
- MCCRACKEN, L. M. & DHINGRA, L. 2002. A short version of the pain anxiety symptoms scale (PASS-20): preliminary development and validity. *Pain Research Management*, 7, 45-50.
- MCELVEEN, M. T., RIEMANN, B. L. & DAVIES, G. J. 2010. Bilateral comparison of propulsion mechanics during single-leg vertical jumping. *The Journal of Strength & Conditioning Research*, 24, 375-381.
- MCERLAIN-NAYLOR, S., KING, M. & PAIN, M. T. G. 2014. Determinants of countermovement jump performance: a kinetic and kinematic analysis. *Journal of Sports Sciences*, 32, 1805-1812.
- MCHUGH, M. P., MAGNUSSON, S. P., GLEIM, G. W. & NICHOLAS, J. A. 1992. Viscoelastic stress relaxation in human skeletal muscle. *Medicine and Science in Sports Exercise*, 24, 1375-1375.
- MCCMAHON, G., MORSE, C. I., BURDEN, A., WINWOOD, K. & ONAMBÉLÉ, G. L. 2014. Impact of range of motion during ecologically valid resistance training protocols on muscle size, subcutaneous fat, and strength. *The Journal of Strength & Conditioning Research*, 28, 245-255.
- MCNAIR, P. J., DOMBROSKI, E. W., HEWSON, D. J. & STANLEY, S. N. 2001. Stretching at the ankle joint: viscoelastic responses to holds and continuous passive motion. *Medicine & Science in Sports & Exercise*, 33, 354-358.
- MELEGARIO, S. M., SIMÃO, R., VALE, R. G., BATISTA, L. A. & NOVAES, J. S. 2006. The influence of the menstrual cycle on the flexibility in practitioners of gymnastics at fitness centers. *Revista Brasileira de Medicina do Esporte*, 12, 125-128.
- MENSE, S. 2010. Functional anatomy of muscle: muscle, nociceptors and afferent fibers. *Muscle pain: understanding the mechanisms*. Springer.

- MENZEL, H.-J., CHAGAS, M. H., SZMUCHROWSKI, L. A., ARAUJO, S. R., DE ANDRADE, A. G. & DE JESUS-MORALEIDA, F. R. 2013a. Analysis of lower limb asymmetries by isokinetic and vertical jump tests in soccer players. *The Journal of Strength & Conditioning Research*, 27, 1370-1377.
- MENZEL, H.-J., DE ANDRADE, A. G. P., ARAÚJO, S. R. & CHAGAS, M. H. Reliability of kinetic variables of squat jumps with different starting positions. International Symposium on Biomechanics in Sports, 2013b. International Society of Biomechanics in Sports.
- MERTZ, L., DOCHERTY, C. J. J. O. D. M. & SCIENCE 2012. Self-described differences between legs in ballet dancers: do they relate to postural stability and ground reaction force measures? 16, 154-160.
- MEYLAN, C. M., NOSAKA, K., GREEN, J. & CRONIN, J. B. 2010. Temporal and kinetic analysis of unilateral jumping in the vertical, horizontal, and lateral directions. *Journal of Sports Sciences*, 28, 545-554.
- MICHELI, L. J., CASSELLA, M., FAIGENBAUM, A. D., SOUTHWICK, H. & HO, V. 2005. Preseason to postseason changes in body composition of professional ballet dancers. *Journal of Dance Medicine & Science*, 9, 56-59.
- MILETIC, D. 2007. Body physique and prior training experience as determinants of SEFIP score for university dancers. *Medical Problems of Performing Artists*, 22, 110-115.
- MILLER, P. & SOULES, M. 1996. The usefulness of a urinary LH kit for ovulation prediction during menstrual cycles of normal women. *Obstetrics & Gynecology*, 87, 13-17.
- MITCHELL, L. A., MACDONALD, R. A. & BRODIE, E. E. 2004. Temperature and the Cold Pressor Test. *The Journal of Pain*, 5, 233-237.
- MIYAMOTO, N., HIRATA, K. & KANEHISA, H. 2017. Effects of hamstring stretching on passive muscle stiffness vary between hip flexion and knee extension maneuvers. *Scandinavian Journal of Medicine & Science in Sports*, 27, 99-106.
- MIYATANI, M., KANEHISA, H., ITO, M., KAWAKAMI, Y. & FUKUNAGA, T. 2004. The accuracy of volume estimates using ultrasound muscle thickness measurements in different muscle groups. *European Journal of Applied Physiology*, 91, 264-272.
- MIYATANI, M., KANEHISA, H., KUNO, S., NISHIJIMA, T. & FUKUNAGA, T. 2001. Validity of ultrasonograph muscle thickness measurements for estimating muscle volume of knee extensors in humans. *European Journal of Applied Physiology*, 86, 203-208.
- MÖLLER-NIELSEN, J. & HAMMAR, M. 1989. Women's soccer injuries in relation to the menstrual cycle and oral contraceptive use. *Medicine and Science in Sports and Exercise*, 21, 126-129.
- MOORE, M. A. & HUTTON, R. 1980. Electromyographic investigation of muscle stretching techniques. *Medicine and Science in Sports Exercise*, 12, 322 - 329.
- MORGAN, D. 1977. Separation of active and passive components of short-range stiffness of muscle. *American Journal of Physiology-Cell Physiology*, 232, 45-49.
- MORISHITA, K., KARASUNO, H., YOKOI, Y., MOROZUMI, K., OGIHARA, H., ITO, T., HANAOKA, M., FUJIWARA, T., FUJIMOTO, T. & ABE, K. 2014. Effects of therapeutic ultrasound on range of motion and stretch pain. *Journal of Physical Therapy Science*, 26, 711-715.
- MORRIN, N. & REDDING, E. 2013. Acute effects of warm-up stretch protocols on balance, vertical jump height, and range of motion in dancers. *Journal of Dance Medicine & Science*, 17, 34-40.
- MORSE, C. I., DEGENS, H., SEYNNES, O. R., MAGANARIS, C. N. & JONES, D. A. 2008. The acute effect of stretching on the passive stiffness of the human gastrocnemius muscle tendon unit. *The Journal of Physiology*, 586, 97-106.

- NAHMAN-AVERBUCH, H., NIR, R.-R., SPRECHER, E. & YARNITSKY, D. 2016. Psychological factors and conditioned pain modulation. *The Clinical Journal of Pain*, 32, 541-554.
- NARICI, M. 1999. Human skeletal muscle architecture studied in vivo by non-invasive imaging techniques: functional significance and applications. *Journal of Electromyography and Kinesiology*, 9, 97-103.
- NEGISHI, S., LI, Y., USAS, A., FU, F. & HUARD, J. 2005. The effect of relaxin treatment on skeletal muscle injuries. *The American Journal of Sports Medicine*, 33, 1816-1824.
- NELSON, R. T. & BANDY, W. D. 2005. An update on flexibility. *The Journal of Strength Conditioning Research*, 27, 10-16.
- NERINI, A. 2015. Media influence and body dissatisfaction in preadolescent ballet dancers and non-physically active girls. *Psychology of Sport and Exercise*, 20, 76-83.
- NEUGARTEN, J., ACHARYA, A., LEI, J. & SILBIGER, S. 2000. Selective estrogen receptor modulators suppress mesangial cell collagen synthesis. *American Journal of Physiology-Renal Physiology*, 279, F309-F318.
- NEWTON, R. U., GERBER, A., NIMPHIUS, S. & SHIM, J. K. 2006. Determination of functional strength imbalance of the lower extremities. *Journal of Strength and Conditioning Research*, 20, 971.
- NIELSEN, J., CRONE, C. & HULTBORN, H. 1993. H-reflexes are smaller in dancers from The Royal Danish Ballet than in well-trained athletes. *European Journal of Applied Physiology and Occupational Physiology*, 66, 116-121.
- NIELSEN, M. S., BARTON, S. D., HATASAKA, H. H. & STANFORD, J. B. 2001. Comparison of several one-step home urinary luteinizing hormone detection test kits to OvuQuick® 22. *Fertility and Sterility*, 76, 384-387.
- NIGMATULLINA, Y., HELLYER, P. J., NACHEV, P., SHARP, D. J. & SEEMUNGAL, B. M. 2013. The neuroanatomical correlates of training-related perceptuo-reflex uncoupling in dancers. *Cerebral Cortex*, 25, 554-562.
- NWANKWO, B. C. & ONYISHI, I. E. 2012. Role of self-efficacy, gender and category of athletes in coping with sports stress. *IFE Psychologia: An International Journal*, 20, 94-101.
- O'SULLIVAN, C., MEANEY, J., BOYLE, G., GORMLEY, J. & STOKES, M. 2009a. The validity of Rehabilitative Ultrasound Imaging for measurement of trapezius muscle thickness. *Manual Therapy*, 14, 572-8.
- O'SULLIVAN, K., MURRAY, E. & SAINSBURY, D. 2009b. The effect of warm-up, static stretching and dynamic stretching on hamstring flexibility in previously injured subjects. *BMC Musculoskeletal Disorders*, 10, 37.
- OCHALA, J., LAMBERTZ, D. & POUSSON, J. V. H. M. 2007a. Changes in muscle and joint elasticity following long-term strength training in old age. *European Journal of Applied Physiology*, 100, 491-498.
- OCHALA, J., LAMBERTZ, D., VAN HOECKE, J. & POUSSON, M. 2007b. Changes in muscle and joint elasticity following long-term strength training in old age. *European Journal of Applied Physiology*, 100, 491-498.
- ODUNAIYA, N., HAMZAT, T. & AJAYI, O. 2005. The effects of static stretch duration on the flexibility of hamstring muscles. *African Journal of Biomedical Research*, 8, 79-82.
- OLIVEIRA, A., BARBIERI, F. & GONÇALVES, M. 2013. Flexibility, torque and kick performance in soccer: Effect of dominance. *Science & Sports*, 28, e67-e70.
- ONAMBELE-PEARSON, N. G. & PEARSON, S. J. 2007. Time-of-day effect on patella tendon stiffness alters vastus lateralis fascicle length but not the quadriceps force-angle relationship. *Journal of Biomechanics*, 40, 1031-1037.

- ONAMBELE, G., BRUCE, S. & WOLEDGE, R. 2006a. Oestrogen status in relation to the early training responses in human thumb adductor muscles. *Acta Physiologica*, 188, 41-52.
- ONAMBÉLÉ, G., BRUCE, S. & WOLEDGE, R. 2004. Effects of voluntary activation level on force exerted by human adductor pollicis muscle during rapid stretches. *Pflugers Archive-European Journal of Physiology* 448, 457-461.
- ONAMBÉLÉ, G., BURGESS, K. & PEARSON, S. 2007a. Gender-Specific in vivo measurement of the structural and mechanical properties of the human patellar tendon. *Journal of Orthopaedic Research*, 25, 1635-1642.
- ONAMBELE, G. L., NARICI, M. V. & MAGANARIS, C. N. 2006b. Calf muscle-tendon properties and postural balance in old age. *Journal of Applied Physiology*, 100, 2048-2056.
- ONAMBÉLÉ, G. N., BURGESS, K. & PEARSON, S. J. 2007b. Gender-specific in vivo measurement of the structural and mechanical properties of the human patellar tendon. *Journal of Orthopaedic Research*, 25, 1635-1642.
- OPPLERT, J., GENTY, J.-B. & BABAUT, N. 2016. Do stretch durations affect muscle mechanical and neurophysiological properties? *International Journal of Sports Medicine*, 37, 673-679.
- ORISHIMO, K. F., KREMENIC, I. J., PAPPAS, E., HAGINS, M. & LIEDERBACH, M. 2009. Comparison of Landing Biomechanics Between Male and Female Professional Dancers. *The American Journal of Sports Medicine*, 37, 2187-2193.
- ORISHIMO, K. F., LIEDERBACH, M., KREMENIC, I. J., HAGINS, M. & PAPPAS, E. 2014. Comparison of landing biomechanics between male and female dancers and athletes, part 1: Influence of sex on risk of anterior cruciate ligament injury. *The American Journal of Sports Medicine*, 42, 1082-1088.
- OVEREND, T. J., CUNNINGHAM, D. A., KRAMER, J. F., LEFCOE, M. S. & PATERSON, D. H. 1992. Knee extensor and knee flexor strength: cross-sectional area ratios in young and elderly men. *Journal of Gerontology*, 47, M204-M210.
- PADULO, J., LAFFAYE, G., ARDIGÒ, L. P. & CHAMARI, K. 2013. Concentric and eccentric: muscle contraction or exercise? *Journal of Human Kinetics*, 37, 5-6.
- PARK, S.-K., STEFANYSHYN, D., LOITZ-RAMAGE, B., HART, D. & RONSKY, J. 2009a. Changing hormone levels during the menstrual cycle affect knee laxity and stiffness in healthy female subjects. *The American Journal of Sports Medicine*, 37, 588-598.
- PARK, S.-K., STEFANYSHYN, D. J., LOITZ-RAMAGE, B., HART, D. A. & RONSKY, J. L. 2009b. Changing hormone levels during the menstrual cycle affect knee laxity and stiffness in healthy female subjects. *The American Journal of Sports Medicine*, 37, 588-598.
- PEARSON, S. & ONAMBÉLÉ, G. 2012. Computation methods affect the reported values of in vivo human tendon stiffness. *Journal of the Mechanical Behaviour of Biomedical Materials*, 5, 291-297.
- PEARSON, S. J. & ONAMBELE, G. N. 2005. Acute changes in knee-extensors torque, fiber pennation, and tendon characteristics. *Chronobiology International*, 22, 1013-1027.
- PEARSON, S. J. & ONAMBELE, G. N. 2006. Influence of time of day on tendon compliance and estimations of voluntary activation levels. *Muscle & Nerve*, 33, 792-800.
- PEIXOTO, G. H., ANDRADE, A. G., MENZEL, H. J., ARAÚJO, S. R., PERTENCE, A. E. & CHAGAS, M. H. 2015. Viscoelastic stress relaxation in the hamstrings before and after a 10-week stretching program. *Muscle & Nerve*, 51, 761-764.
- PEIXOTO, G. H., MENZEL, H. J., MAGALHÃES, F. A., PEREIRA, B. M., PERTENCE, A. E. M., CARNEIRO, R. L. & CHAGAS, M. H. Comparison of two methods to calculate passive

- muscle stiffness in human. International Symposium on Biomechanics in Sports, 2011. International Society of Biomechanics in Sports.
- PEREIRA, B. M. 2016. *Respostas biomecânica e sensorial dos músculos posteriores da coxa submetidos à vibração mecânica localizada e ao treinamento da flexibilidade com sobreposição da vibração mecânica localizada*. Doutorado, Universidade Federal de Minas Gerais.
- PESSALI-MARQUES, B. 2015. *Comparação do efeito agudo do alongamento dos músculos posteriores da coxa nas variáveis biomecânicas e na primeira sensação de alongamento em adultos jovens treinados e não-treinados em flexibilidade*. Mestrado Dissertacao, Universidade Federal de Minas Gerais.
- PESSALI-MARQUES, B. 2016. A Comparison of different equipment used to measure and train flexibility. *Revista Movimenta*, 9, 653-658.
- PESSALI-MARQUES, B., BEINROTH, R., PINTO, K. & MENDES, T. 2012. Comparação das respostas termorregulatórias de bailarinas durante um ensaio e um espetáculo. *Revista Mineira de Educacao Fisica*, 2146-2156.
- PESSALI-MARQUES, B., CHAGAS, M. H., ANDRADE, A. G. P., MILANEZ-REIS, M., CABIDO, C. E. T. & MCEWAN, I. 2016. Comparison of rom improvement during six stretch repetitions between trained and non-trained in flexibility subjects. *22nd Congress of the European Society of Biomechanics*. Lyon.
- PESSALI-MARQUES, B., PEIXOTO, G. H., CABIDO, C., TOURINO, F., ANDRADE, A. G. & CHAGAS, M. H. 2015. Instrumentalização de um teste de extensão do joelho: Confiabilidade das medidas de variáveis biomecânicas e sensoriais. *XVI Congresso Brasileiro de Biomecânica*. Florianópolis.
- PHILLIPS, S., SANDERSON, A., BIRCH, K., BRUCE, S. & WOLEDGE, R. 1996. Changes in maximal voluntary force of human adductor pollicis muscle during the menstrual cycle. *The Journal of Physiology*, 496, 551-557.
- POLLARD, C. D., BRAUN, B. & HAMILL, J. 2006. Influence of gender, estrogen and exercise on anterior knee laxity. *Clinical Biomechanics*, 21, 1060-1066.
- PRADINES, M., MASSON, I., PORTERO, R., GIROUX, C. & GRACIES, J.-M. 2016. Muscle lengthening and structural changes in the muscle-tendon complex of triceps surae after 1 year of rehabilitation including a daily self-stretch program in patients with chronic hemiparesis. *Annals of Physical Rehabilitation Medicine*, 59, e73.
- PRATI, S. R. A. & PRATI, A. R. C. 2006. Níveis de aptidão física e análise de tendências posturais em bailarinas clássicas. *Revista Brasileira de Cineantropometria & Desempenho Humano*, 8, 80-87.
- PRENTICE, W. 2009. *Therapeutic modalities for sports medicine and athletic training*, Boston, MA, McGraw-Hill.
- RADELL, S. A., ADAME, D. D., JOHNSON, T. C. & COLE, S. P. 1993. Dance experiences associated with body-image and personality among college students: A comparison of dancers and nondancers. *Perceptual and Motor Skills*, 77, 507-513.
- RAHNAMA, N., LEES, A. & BAMBAECICHI, E. 2005. A comparison of muscle strength and flexibility between the preferred and non-preferred leg in English soccer players. *Ergonomics*, 48, 1568-1575.
- RAMEL, E. M., MORITZ, U. & JARNLO, G.-B. 1999. Validation of a pain questionnaire (SEFIP) for dancers with a specially created test battery. *Medical Problems of Performing Artists*, 14, 196-203.
- REAZ, M., HUSSAIN, M. & MOHD-YASIN, F. 2006. Techniques of EMG signal analysis: detection, processing, classification and applications. *Biological Procedures*, 8, 11-35.

- RIEMANN, B. L., DEMONT, R. G., RYU, K. & LEPHAR, S. M. 2001. The Effects of Sex, Joint Angle, and the gastrocnemius muscle on Passive ankle joint complex Stiffness. *Journal of Athletic Training*, 36, 369-377.
- RODACKI, A. L., FOWLER, N. E. & BENNETT, S. 2001. Multi-segment coordination: fatigue effects. *Medicine Science in Sports Exercise*, 33, 1157-1167.
- ROGAN, S., RADLINGER, L., IMHASLY, C., KNEUBUEHLER, A. & HILFIKER, R. 2015. Validity study of a jump mat compared to the reference standard force plate. *Asian Journal of Sports Medicine*, 6.
- ROWLEY, K. M., JARVIS, D. N., KURIHARA, T., CHANG, Y.-J., FIETZER, A. L. & KULIG, K. 2015. Toe flexor strength, flexibility and function and flexor hallucis longus tendon morphology in dancers and non-dancers. *Medical Problems of Performing Artists*, 30, 152.
- ROZZI, S. L., LEPHART, S. M., GEAR, W. S. & FU, F. H. 1999. Knee joint laxity and neuromuscular characteristics of male and female soccer and basketball players. *The American Journal of Sports Medicine*, 27, 312-319.
- RUBINI, E. C., SOUZA, A. C., MELLO, M. L., BACURAU, R. F., CABRAL, L. F. & FARINATTI, P. T. 2011. Immediate effect of static and proprioceptive neuromuscular facilitation stretching on hip adductor flexibility in female ballet dancers. *Journal of Dance Medicine & Science*, 15, 177-181.
- RYAN, E., BECK, T., HERDA, T., HULL, H., HARTMAN, M., STOUT, J. & CRAMER, J. 2008a. Do practical durations of stretching alter muscle strength? A dose-response study. *Medicine Science Sports Exercise*, 40, 1529-37.
- RYAN, E., HERDA, T., COSTA, P., WALTER, A. & CRAMER, J. 2012. Dynamics of viscoelastic creep during repeated stretches. *Scandinavian Journal Medicine Science Sports*, 22, 179-84.
- RYAN, E. D., BECK, T. W., HERDA, T. J., HULL, H. R., HARTMAN, M. J., COSTA, P. B., DEFREITAS, J. M., STOUT, J. R. & CRAMER, J. T. 2008b. The time course of musculotendinous stiffness responses following different durations of passive stretching. *journal of orthopaedic & sports physical therapy*, 38, 632-639.
- RYAN, E. D., HERDA, T. J., COSTA, P. B., WALTER, A. A., HOGE, K. M., STOUT, J. R. & CRAMER, J. T. 2010. Viscoelastic creep in the human skeletal muscle–tendon unit. *European Journal of Applied Physiology*, 108, 207-211.
- SADEGHI, H., ALLARD, P., PRINCE, F. & LABELLE, H. 2000. Symmetry and limb dominance in able-bodied gait: a review. *Gait & Posture*, 12, 34-45.
- SAFRAN, M. R., SEABER, A. V. & GARRETT, W. E. 1989. Warm-up and muscular injury prevention an update. *Sports Medicine*, 8, 239-249.
- SAMADI, H., RAJABI, R., MINOONEJAD, H. & AGHAIARI, A. 2009. Asymmetries in flexibility, balance and power associated with preferred and non-preferred leg. *World Journal of Sport Sciences*, 2, 38-42.
- SANDS, W. A. 1990. Flexibility. In: GEORGE, S. G. (ed.) *Gymnastics Safety Manual*. Second ed. Louisiana: USGF Publications.
- SANTIAGO, D. B. D. A. & SANTOS, D. L. D. 2013. Satisfação com a imagem corporal e comportamentos de risco para transtornos alimentares em meninas praticantes e não praticantes de dança. *Revista Brasileira de Nutrição Esportiva*, 7.
- SARWAR, R., NICLOS, B. B. & RUTHERFORD, O. 1996. Changes in muscle strength, relaxation rate and fatiguability during the human menstrual cycle. *The Journal of Physiology*, 493, 267-272.

- SAUGSTAD, L. F. 1991. Is persistent pelvic pain and pelvic joint instability associated with early menarche and with oral contraceptives? *European Journal of Obstetrics & Gynecology and Reproductive Biology*, 41, 203-206.
- SCAFOGLIERI, A., TRESIGNIE, J., PROVYN, S., CLARYS, J. P. & BAUTMANS, I. 2012. Reproducibility, accuracy and concordance of Accutrend® Plus for measuring circulating lipid concentration in adults. *Biochemia Medica*, 22, 100-108.
- SCHEPER, M. C., DE VRIES, J. E., DE VOS, R., VERBUNT, J., NOLLET, F. & ENGELBERT, R. H. 2012. Generalized joint hypermobility in professional dancers: a sign of talent or vulnerability? *Rheumatology*, 52, 651-658.
- SCHMIDTBLEICHER, D. 1992. Training for power events. *Strength and Power in Sport*, 1, 381-395.
- SCIORE, P., FRANK, C. B. & HART, D. A. 1998. Identification of sex hormone receptors in human and rabbit ligaments of the knee by reverse transcription-polymerase chain reaction: Evidence that receptors are present in tissue from both male and female subjects. *Journal of Orthopaedic Research*, 16, 604-610.
- SEYFARTH, A., BLICKHAN, R. & VAN LEEUWEN, J. 2000. Optimum take-off techniques and muscle design for long jump. *Journal of Experimental Biology*, 203, 741-750.
- SHADMEHR, A., HEJAZIA, S. M., OLYAEI, G. & TALEBIAN, S. 2016. Effect of Countermovement and Arm Swing on Vertical Stiffness and Jump Performance. *Journal of Contemporary Medical Sciences*, 2, 25-27.
- SHERMAN, B. M. & KORENMAN, S. G. 1974. Measurement of plasma LH, FSH, estradiol and progesterone in disorders of the human menstrual cycle: the short luteal phase. *The Journal of Clinical Endocrinology Metabolism*, 38, 89-93.
- SHERMAN, B. M. & KORENMAN, S. G. 1975. Hormonal characteristics of the human menstrual cycle throughout reproductive life. *The Journal of Clinical Investigation*, 55, 699-706.
- SHERMAN, B. M., WEST, J. H. & KORENMAN, S. G. 1976. The menopausal transition: analysis of LH, FSH, estradiol, and progesterone concentrations during menstrual cycles of older women. *The Journal of Clinical Endocrinology Metabolism*, 42, 629-636.
- SHIKATA, J., SANADA, H., YAMAMURO, T. & TAKEDA, T. 1979. Experimental studies of the elastic fiber of the capsular ligament: influence of ageing and sex hormones on the hip joint capsule of rats. *Acta Orthopaedica Scandinavica*, 7, 21-27.
- SHOUPE, D. & KJOS, S. L. 2006. *The Handbook of Contraception*, Human Press Incorporated.
- SHRIER, I. 2004a. Does stretching improve performance? A systematic and critical review of the literature. *Clinical Journal of Sports Medicine*, 14, 267-273.
- SHRIER, I. 2004b. Does stretching improve performance?: a systematic and critical review of the literature. *Clinical Journal of sport medicine*, 14, 267-273.
- SHULTZ, S. J., CARCIA, C. R. & PERRIN, D. H. 2004a. Knee joint laxity affects muscle activation patterns in the healthy knee. *Journal of Electromyography and Kinesiology*, 14, 475-483.
- SHULTZ, S. J., GANSNEDER, B. M., SANDER, T. C., KIRK, S. E. & PERRIN, D. H. 2006. Absolute serum hormone levels predict the magnitude of change in anterior knee laxity across the menstrual cycle. *Journal of Orthopaedic Research*, 24, 124-131.
- SHULTZ, S. J., KIRK, S. E., JOHNSON, M. L., SANDER, T. C. & PERRIN, D. H. 2004b. Relationship between sex hormones and anterior knee laxity across the menstrual cycle. *Medicine and Science in Sports and Exercise*, 36.

- SHULTZ, S. J. & SCHMITZ, R. J. 2009. Effects of transverse and frontal plane knee laxity on hip and knee neuromechanics during drop landings. *The American Journal of Sports Medicine*, 37, 1821-1830.
- SILVA, A. M. B. D. & ENUMO, S. R. F. 2016. Pain and injury in adolescent dancers: systematic review. *Revista Dor*, 17, 132-135.
- SILVA, S., OLIVEIRA, D., JAQUES, M. & ARAÚJO, R. 2010. Efeito da crioterapia e termoterapia associados ao alongamento estático na flexibilidade dos músculos isquiotibiais. *Motricidade*, 6, 55-62.
- SILVEIRA, R. D. N. D., FARIAS, J. M. D., ALVAREZ, B. R., BIF, R. & VIEIRA, J. 2011. Acute effect of static stretching in agonist muscle on the levels of activation and on strength performance of trained men. *Revista Brasileira de Medicina do Esporte*, 17, 26-30.
- SILVERTHORN, D. & MICHAEL, J. 2013. Cold stress and the cold pressor test. *Advances in Physiology Education*, 37, 93-6.
- SLAUTERBECK, J., CLEVINGER, C., LUNDBERG, W. & BURCHFIELD, D. M. 1999. Estrogen level alters the failure load of the rabbit anterior cruciate ligament. *Journal of Orthopaedic Research*, 17, 405-408.
- SLAUTERBECK, J. R., FUZIE, S. F., SMITH, M. P., CLARK, R. J., XU, K. T., STARCH, D. W. & HARDY, D. M. 2002. The menstrual cycle, sex hormones, and anterior cruciate ligament injury. *Journal of Athletic Training*, 37, 275.
- SLEPIAN, P. M., FRANCE, C. R., RHUDY, J. L., HIMAWAN, L. K., GÜERECA, Y. M., KUHN, B. L. & PALIT, S. 2017. Behavioral Inhibition and Behavioral Activation are Related to Habituation of Nociceptive Flexion Reflex, but Not Pain Ratings. *The Journal of Pain*, 18, 349-358.
- SMITH, A., KOUTEDAKIS, Y. & WYON, M. 2013. A comparison of strength and stretch interventions on active and passive ranges of movement in dancers: a randomized controlled trial. *The Journal of Strength & Conditioning Research*, 27, 3053-3059.
- SMITH, C. M., WALKER, A. W., HOSKEN, I. T., CHUA, B. E., ZHANG, C., HAIDAR, M. & GUNDLACH, A. L. 2014. Relaxin-3/RXFP3 networks: an emerging target for the treatment of depression and other neuropsychiatric diseases? *Frontiers in Pharmacology*, 5, 46.
- SOUZA, R. B. & POWERS, C. M. 2009. Predictors of hip internal rotation during running: an evaluation of hip strength and femoral structure in women with and without patellofemoral pain. *The American Journal of Sports Medicine*, 37, 579-587.
- STENING, K., ERIKSSON, O., WAHREN, L., BERG, G., HAMMAR, M. & BLOMQVIST, A. 2007. Pain sensations to the cold pressor test in normally menstruating women: comparison with men and relation to menstrual phase and serum sex steroid levels. *American Journal of Physiology-Regulatory, Integrative and Comparative Physiology*, 293, R1711-R1716.
- STEWART, D., MACALUSO, A. & DE VITO, G. 2003. The effect of an active warm-up on surface EMG and muscle performance in healthy humans. *European journal of applied physiology*, 89, 509-513.
- STRAUSS, J. F. & BARBIERI, R. L. 2013. *Yen & Jaffe's Reproductive Endocrinology E-Book: Physiology, Pathophysiology, and Clinical Management*, Elsevier Health Sciences.
- SULLIVAN, M. K., DEJULIA, J. J. & WORRELL, T. W. 1992. Effect of pelvic position and stretching method on hamstring muscle flexibility. *Medicine and Science in Sports and Exercise*, 24, 1383-1389.
- SVANTESSON, U., OSTERBERG, U., THOME, R. & GRIMBY, G. 1998. Muscle fatigue in a standing heel-rise test. *Scandinavian journal of rehabilitation medicine*, 30, 67-72.

- SYMMONS, D., VAN HEMERT, A., VANDENBROUCKE, J. T. & VALKENBURG, H. 1991. A longitudinal study of back pain and radiological changes in the lumbar spines of middle aged women. II. Radiographic findings. *Annals of the rheumatic diseases*, 50, 162-166.
- SYROP, C. H. & HAMMOND, M. G. 1987. Diurnal variations in midluteal serum progesterone measurements. *Fertility and sterility*, 47, 67-70.
- TAJET-FOXELL, B. & ROSE, F. D. 1995. Pain and pain tolerance in professional ballet dancers. *British journal of sports medicine*, 29, 31-34.
- TAYLOR, D. C., BROOKS, D. E. & RYAN, J. B. 1997. Viscoelastic characteristics of muscle: passive stretching versus muscular contractions. *Medicine and Science in Sports and Exercise*, 29, 1619-1624.
- TAYLOR, D. C., DALTON JR, J. D., SEABER, A. V. & GARRETT JR, W. E. 1990. Viscoelastic properties of muscle-tendon units: the biomechanical effects of stretching. *The American journal of sports medicine*, 18, 300-309.
- TEIXEIRA, A. L. D. S., FERNANDES JÚNIOR, W., MARQUES, F. A. D., LACIO, M. L. D. & DIAS, M. R. C. 2012a. Influence of different phases of menstrual cycle on flexibility of young women. *Revista Brasileira de Medicina do Esporte*, 18, 361-364.
- TEIXEIRA, A. L. D. S., JUNIOR, W. F., MARQUES, F. A. D., LACIO, M. L. D. & DIAS, M. R. C. 2012b. Influence of different phases of menstrual cycle on flexibility of young women. *Revista Brasileira de Medicina do Esporte*, 18, 361-364.
- THOMAS, H. & TARR, J. 2009. Dancers' perceptions of pain and injury: positive and negative effects. *Journal of Dance Medicine & Science*, 13, 51-59.
- TIGHE, J., MCMANUS, I., DEWHURST, N. G., CHIS, L. & MUCKLOW, J. 2010. The standard error of measurement is a more appropriate measure of quality for postgraduate medical assessments than is reliability: an analysis of MRCP (UK) examinations. *BMC Medical Education*, 10, 40.
- TO, W. K., WONG, M. & CHAN, K. 1995. The effect of dance training on menstrual function in collegiate dancing students. *Australian and New Zealand journal of obstetrics and gynaecology*, 35, 304-309.
- TOMMASO, M. D. 2011. Pain Perception during Menstrual Cycle. *Current pain and headache reports*, 15, 400 - 406.
- TRELOAR, A. E., BOYNTON, R. E., BEHN, B. G. & BROWN, B. W. 1967. Variation of the human menstrual cycle through reproductive life. *International journal of fertility*, 12, 77-126.
- TURNER, C., CROW, S., CROWTHER, T., KEATING, B., SAUPAN, T., PYFER, J., VIALPANDO, K. & LEE, S.-P. 2018. Preventing non-contact ACL injuries in female athletes: What can we learn from dancers? *Physical Therapy in Sport*, 31, 1-8.
- ULDBJERG, N. & ULMSTEN, U. 1990. The physiology of cervical ripening and cervical dilatation and the effect of abortifacient drugs. *Bailliere's clinical obstetrics and gynaecology*, 4, 263-282.
- UNICK, J., KIEFFER, H. S., CHEESMAN, W. & FEENEY, A. 2005. The acute effects of static and ballistic stretching on vertical jump performance in trained women. *Journal of strength and conditioning research*, 19, 206.
- UNKNOWN 2010. Plug in Gait.
- VAN DILLEN, L., MCDONNELL, M., FLEMING, D. & SAHRMANN, S. 2000. Effect of knee and hip position on hip extension range of motion in individuals with and without low back pain. *Journal of Orthopaedic & Sports Physical Therapy*, 30.

- VAN GOOZEN, S. H., WIEGANT, V. M., ENDERT, E., HELMOND, F. A. & VAN DE POLL, N. E. 1997. Psychoendocrinological assessment of the menstrual cycle: the relationship between hormones, sexuality, and mood. *Archives of Sexual Behavior*, 26, 359-382.
- VAN HOOFF, M., VOORHORST, F., KAPTEIN, M., HIRASING, R., KOPPENAAL, C. & SCHOEMAKER, J. 1998. Relationship of the menstrual cycle pattern in 14-17 year old adolescents with gynaecological age, body mass index and historical parameters. *Human reproduction (Oxford, England)*, 13, 2252-2260.
- VANEZIS, A. & LEES, A. 2005. A biomechanical analysis of good and poor performers of the vertical jump. *Ergonomics*, 48, 1594-1603.
- VAVERKA, F., JANDAČKA, D., ZAHRADNÍK, D., UCHYTIL, J., FARANA, R., SUPEJ, M. & VODIČAR, J. 2016. Effect of an arm swing on countermovement vertical jump performance in elite volleyball players. *Journal of human kinetics*, 53, 41-50.
- VILLEMURE, C. & BUSHNELL, C. M. 2002. Cognitive modulation of pain: how do attention and emotion influence pain processing? *Pain*, 95, 195-199.
- VITZTHUM, V. J. & RINGHEIM, K. 2005. Hormonal Contraception and Physiology: A Research-based Theory of Discontinuation Due to Side Effects. *Studies in family planning*, 36, 13-32.
- VOLKERDING, K. & KETCHAM, C. 2013. Biomechanics and Proprioceptive Differences during Drop Landings between Dancers and Non-dancers. *International Journal of Exercise Science*, 6, 4.
- VON BAEYER, C. L., PIIRA, T., CHAMBERS, C. T., TRAPANOTTO, M. & ZELTZER, L. K. 2005. Guidelines for the cold pressor task as an experimental pain stimulus for use with children. *The journal of Pain*, 6, 218-227.
- VOSKANIAN, N. 2013. ACL Injury prevention in female athletes: review of the literature and practical considerations in implementing an ACL prevention program. *Current reviews in musculoskeletal medicine*, 6, 158-63.
- WALLMANN, H. W., MERCER, J. A. & MCWHORTER, J. W. 2005. Surface electromyographic assessment of the effect of static stretching of the gastrocnemius on vertical jump performance. *Journal of Strength and Conditioning Research*, 19, 684.
- WARREN, M. P., BROOKS-GUNN, J., FOX, R. P., HOLDERNESS, C. C., HYLE, E. P. & HAMILTON, W. G. 2002. Osteopenia in exercise-associated amenorrhea using ballet dancers as a model: a longitudinal study. *The journal of clinical endocrinology metabolism*, 87, 3162-3168.
- WARREN, M. P., BROOKS-GUNN, J., FOX, R. P., HOLDERNESS, C. C., HYLE, E. P., HAMILTON, W. G. & HAMILTON, L. 2003. Persistent osteopenia in ballet dancers with amenorrhea and delayed menarche despite hormone therapy: a longitudinal study. *Fertility and sterility*, 80, 398-404.
- WATSON, P. E. & ROBINSON, M. F. 1965. Variations in body-weight of young women during the menstrual cycle. *British Journal of Nutrition*, 19, 237-248.
- WEINBERG, R., VERNAU, D. & HORN, T. 2013. Playing through pain and injury: Psychosocial considerations. *Journal of Clinical Sport Psychology*, 7, 41-59.
- WEIR, D. E., TINGLEY, J. & ELDER, G. C. 2005. Acute passive stretching alters the mechanical properties of human plantar flexors and the optimal angle for maximal voluntary contraction. *European Journal of Applied Physiology*, 93, 614-623.
- WEPLER, C. H. & MAGNUSSON, S. P. 2010. Increasing muscle extensibility: a matter of increasing length or modifying sensation? *Physical therapy*, 90, 438-449.

- WHITE, C. P., HITCHCOCK, C. L., VIGNA, Y. M. & PRIOR, J. C. 2011. Fluid retention over the menstrual cycle: 1-year data from the prospective ovulation cohort. *Obstetrics gynecology international*, 2011.
- WILKE, J., MACCHI, V., DE CARO, R. & STECCO, C. 2018. Fascia thickness, aging and flexibility: is there an association? *Journal of Anatomy*.
- WILSON, G., ELLIOTT, B. & WOOD, G. 1992. Stretch shorten cycle performance enhancement through flexibility training. *Medicine and Science in Sports and Exercise*, 24, 116-123.
- WILSON, G., MURPHY, A. & PRYOR, J. 1994. Musculotendinous stiffness: its relationship to eccentric, isometric, and concentric performance. *Journal of applied physiology*, 76, 2714-2719.
- WILSON, J. M. & FLANAGAN, E. P. 2008. The role of elastic energy in activities with high force and power requirements: a brief review. *The Journal of Strength & Conditioning Research*, 22, 1705-1715.
- WITVROUW, E., MAHIEU, N., DANNEELS, L. & MCNAIR, P. 2004. Stretching and injury prevention. *Sports medicine*, 34, 443-449.
- WÓJCIK, M. & SIATKOWSKI, I. 2014. Selected lower extremity flexibility tests as an element of functional assessment for ballet school students—Preliminary observation. *Polish Annals of Medicine*, 21, 20-23.
- WOJTYS, E. M., HUSTON, L. J., BOYNTON, M. D., SPINDLER, K. P. & LINDENFELD, T. N. 2002. The effect of the menstrual cycle on anterior cruciate ligament injuries in women as determined by hormone levels. *The American journal of sports medicine*, 30, 182-188.
- WOJTYS, E. M., HUSTON, L. J., LINDENFELD, T. N., HEWETT, T. E. & GREENFIELD, M. L. V. 1998. Association between the menstrual cycle and anterior cruciate ligament injuries in female athletes. *The American journal of sports medicine*, 26, 614-619.
- WREJE, U., ISACSSON, D. & ABERG, H. 1997. Oral contraceptives and back pain in women in a Swedish community. *International journal of epidemiology*, 26, 71-74.
- WYON, M., ALLEN, N., ANGIOI, M., NEVILL, A. & TWITCHETT, E. 2006. Anthropometric factors affecting vertical jump height in ballet dancers. *Journal of Dance Medicine and Science*, 10, 106-110.
- WYON, M., FELTON, L. & GALLOWAY, S. 2009. A comparison of two stretching modalities on lower-limb range of motion measurements in recreational dancers. *The Journal of Strength & Conditioning Research*, 23, 2144-2148.
- WYON, M., HARRIS, J., BROWN, D. & CLARK, F. 2013. Bilateral differences in peak force, power, and maximum pli  depth during multiple grande Jet s. *Medical Problems of Performing Artists*, 28, 28-32.
- WYON, M., HUTCHINGS, K., WELLS, A. & NEVILL, A. 2014. Body mass index, nutritional knowledge, and eating behaviors in elite student and professional ballet dancers. *Clinical Journal of Sport Medicine*, 24, 390-396.
- XANNE, A. K. & DE JONGE, J. 2003. Effects of the Menstrual Cycle on Exercise Performance. *Sports Medicine*, 33, 833-851.
- YANG, J. F. & WINTER, D. A. 1983. Electromyography reliability in maximal and submaximal isometric contractions. *Archives of physical medicine and rehabilitation*, 64, 417-420.
- YEH, C.-Y., CHEN, J.-J. & TSAI, K.-H. 2007. Quantifying the effectiveness of the sustained muscle stretching treatments in stroke patients with ankle hypertonia. *Journal of Electromyography and Kinesiology*, 17, 453-461.

- YEH, C.-Y., TSAI, K.-H. & CHEN, J.-J. 2005. Effects of prolonged muscle stretching with constant torque or constant angle on hypertonic calf muscles. *Archives of physical medicine and rehabilitation*, 86, 235-241.
- YLINEN, J., KANKAINEN, T., KAUTIAINEN, H., REZASOLTANI, A., KUUKKANEN, T. & HÄKKINEN, A. 2009. Effect of stretching on hamstring muscle compliance. *Journal of rehabilitation medicine*, 41, 80-84.
- YOSHIOKA, S., NAGANO, A., HAY, D. C. & FUKASHIRO, S. 2010. The effect of bilateral asymmetry of muscle strength on jumping height of the countermovement jump: A computer simulation study. *Journal of sports sciences*, 28, 209-218.
- YOUNG, W., MC LEAN, B. & ARDAGNA, J. 1995. Relationship between strength qualities and sprinting performance. *Journal of Sports Medicine and Physical Fitness*, 35, 13-19.
- YURT, Y., YAKUT, Y. & SENER, G. 2013. Validity and reliability of turkish version of self estimated functional inability because of pain (SEFIP) questionnaire and determination of pain profile in a turkish folk dancer group. *Annals of the Rheumatic Diseases*, 71, 701-701.
- ZAZULAK, B., PATERNO, M., MYER, G., ROMANI, W. & HEWETT, T. 2006. The effects of the menstrual cycle on anterior knee laxity. *Sports medicine*, 36, 847-862.
- ZVOLENSKY, M., GOODIE, J., MCNEIL, D., SPERRY, J. & SORRELL, J. 2001. Anxiety sensitivity in the prediction of pain-related fear and anxiety in a heterogeneous chronic pain population. *Behaviour research therapy*, 39, 683-696.

Crewe Week- February 8th-12th 2016

Event Title:	Body Conditioning/Flexibility training
Event Description/advert listing: Please give as much information as possible – i.e. format of session, benefit to students, what they will learn etc. – sell it! * If the event is already listed elsewhere on the website, you can just provide the link here	Basic concepts of flexibility training. How to do it properly, why to do it and how it can improve movements of dance and daily life.
Date(s):	09 th February 2016
Time(s): *Workshops could run for one or two hours. They could also function as a course with separate individual sessions that could be booked separately or as a whole block—	11-12:30 (1 Hour practical)
Venue: *Please book your book in advance. We will try to concentrate all the workshops in <u>Delaney and Francis Wood</u>, so changing from one room to another will be easier.	AXIS Art Centre- Contemporary Arts Building Room CCA-1:41
Maximum number of Participants:	20
Contact Details for any queries:	Sets.cheshire@mmu.ac.uk Barbara.pessali-marques@stu.mmu.ac.uk
Closing Date for Registrations: <i>Please let us know when you would like this listing to be removed from our website</i>	07 th February 2016
Skills Gained*: (e.g. Leadership / Organisation / Time-management / Negotiation / Team-work / Enterprise / Commercial Awareness / Problem-solving / Communication / Language skills / Knowledge / Finance / Sustainability awareness / Global perspectives / industry knowledge and insight / adaptability / dealing with change / personal development / * Please remember this list is not exhaustive	- Knowledge -Facilitation Skills -Active Research Evidence -Work experience -Personal development



THE INFLUENCE OF MENSTRUAL CYCLE PHASE ON FLEXIBILITY AND JUMP PERFORMANCE IN DANCERS: INTERACTIONS WITH MTU STRUCTURAL AND FUNCTIONAL CHARACTERISTICS

Bárbara Pessali-Marques, Gladys Onambele-Person*, Adrian Burden*, Vincent Cacalano* and Islay McEwan**

*Manchester Metropolitan University
b.pessali-marques@mmu.ac.uk

Abstract: The menstrual cycle occurs as a direct result of variations of blood concentrations of female hormones. It is composed of three phases: follicular, ovulatory and luteal (Bell et al., 2014a, Teixeira et al., 2012b). Some studies found modifications in joint laxity (Bell et al., 2014a), tendon stiffness (Onambélé et al., 2007a), muscle strength, proprioception and muscle activation patterns, in line with circulating levels of female hormones. However, other studies found no difference in similar variables (Burgess et al., 2010, Teixeira et al., 2012b).

If the presence of relatively high levels of oestrogen and/or progesterone were associated with decreased stiffness of ligamentous tissues, this reduction would increase initial muscle shortening velocity, degree of muscle shortening, muscle fascicle pennation angle at rest and during contraction, ultimately affecting force-production capacity. During the stretch-shortening cycle, a stiffer MTU induces better transmission of the force via the tendon directly to the bone and shortens the coupling time between eccentric and concentric phases (Ochala et al., 2007a). In addition, MTU stiffness is known to be connected to the central nervous system, once the sensation of pain during the stretches, controlled by mechanoreceptors, is influenced by stiffness. This way, a reduced stiffness would lend itself to greater tendon deformation for equivalent forces (Onambélé et al., 2007a).

Considering that flexibility and jumping abilities, both crucial for dancers' performance, could be influenced by MTU stiffness, and that this (Brughelli and Cronin, 2008a) appears to be affected by key menstrual cycle hormones, the aim of this research is to determine the effects of MCP in MTU characteristics in jump and flexibility performance in dancers and non-dancers to predict any modifications in dance performance. Also, determine whether different levels of dancers are equally

affected by the endocrine fluctuations induced through the MCP. This will allow the development of training strategies to improve performance and potentially avoid injuries.

Methods: The volunteers will receive a kit to measure the ovulation phase. To confirm the menstrual cycle phase, venepuncture samples and blood chemiluminescent tests will be carried out. Testing will take place on four days: familiarization, follicular, ovulatory and luteal phases. Forms will be filled to characterize the subjects (personal information, injuries and exercise practised).

Anthropometry and ultrasound images: body weight, height, percentage of fat, circumferences and length of the segments. Ultrasound images of the MTU of the biceps femoris and rectus femoris.

Passive flexibility: supine on the Cybex isokinetic dynamometer, with the lever arm attached to the ankle. The hamstrings will be stretched until the maximum tolerated by the participant. They will press in control when they start to feel the stretching; 6 trials will be done.

Active flexibility: standing with feet parallel on Cybex, one ankle attached at the lever arm; 3 trials of flexion and extension of the hip will be done.

Vertical jumps: countermovement jump and squat jump from a force platform; 3 trials of each jump.

Passive stretch: 4 series of passive static stretch for 30 seconds will be done supine on Cybex.

Tests will be recorded (3D analyses) to analyse the influence of pelvic movement and electromyography of the agonists and antagonist muscles will be done.

Participants: student and professional dancers, non-dancers, 18-30 years. Sample size: 12 per group.

Keywords: Dancers, Flexibility, Jumps, Menstrual Cycle Phases, Muscle-tendon Unit.

Presentation modality: 3 minute + 1 slide

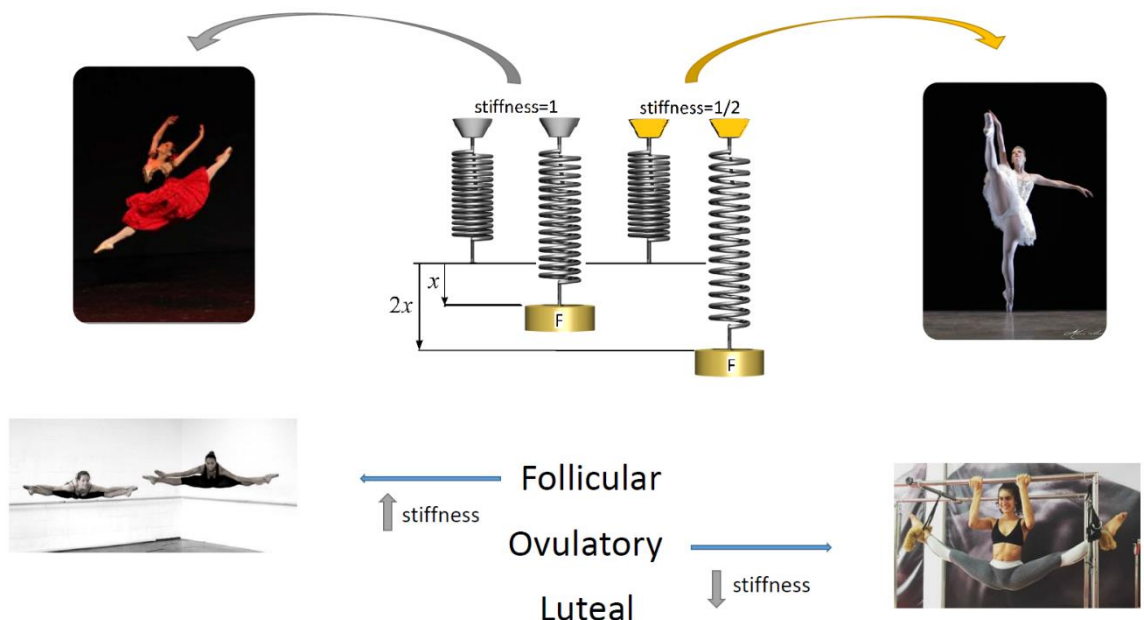



COMPARISON OF ROM IMPROVEMENT DURING SIX STRETCH REPETITIONS BETWEEN TRAINED AND NON-TRAINED IN FLEXIBILITY SUBJECTS

Bárbara Pessali-Marques(1); Mauro H.Chagas(2); André G.P.Andrade(2); Matheus Milanez-Reis(2); Christian Cabido(3); Islay McEwan(1).

1. Manchester Metropolitan University, United Kingdom; 2. Federal University of Minas Gerais, Brazil 3. Federal University of Maranhão, Brazil.

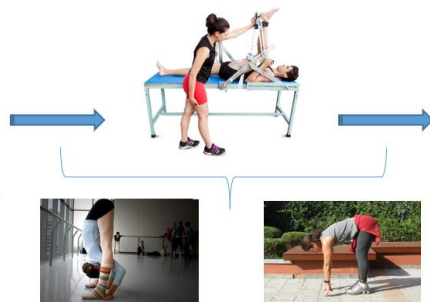
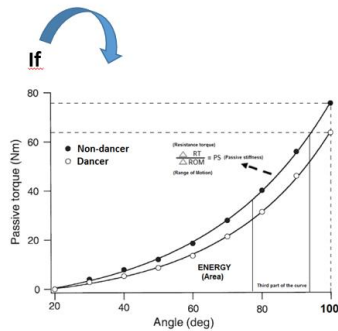

SERIE	GROUP			
	TF		NTF	
	ROM _{increase} (%)	SD	ROM _{increase} (%)	SD
1	1.05	±0.03	1.03	±0.03
2	1.06	±0.03	1.05	±0.03
3*	1.07	±0.03	1.04	±0.04
4*	1.08	±0.03	1.05	±0.05
5*	1.09	±0.03	1.06	±0.05
6*	1.09	±0.03	1.06	±0.06

TF – Trained in flexibility; TNF – Non-trained in flexibility
*p<0,05

Range of Motion_{increase}

Range of Motion_{increase}

Scholarship student of Capes – Brazil. 99999.002176/2015-07

COMPARISON OF ROM IMPROVEMENT DURING SIX STRETCH REPETITIONS BETWEEN TRAINED AND NON-TRAINED IN FLEXIBILITY SUBJECTS

Bárbara Pessali-Marques(1); Mauro H.Chagas(2); André G.P.Andrade(2); Matheus Milanez-Reis(2); Christian Cabido(3); Islay McEwan(1).

1.Manchester Metropolitan University, United Kingdom; 2.Federal University of Minas Gerais, Brazil
3.Federal University of Maranhão, Brazil.

Introduction

Dancers exhibited less unilateral isometric force and longer half-relaxation times than non-trained participants, which may be reflected by differences in tissue compliance, neural organization or muscle stiffness[1]. Volunteers less stiff showed greater range of motion (ROM) during stretching[2], if dancers were considered less stiff than non-trained, it is possible hypothesize that the increase in ROM between the series of stretching will be greater in dancers than in non-trained. The aim of this study was to compare the ROM_{increase} in six series of passive stretch with constant torque between trained in flexibility (TF) and non-trained in flexibility (NTF) groups.

Methods

Participated in this study 46 men with no musculoskeletal injury, 23 dancers in the TF (age:21.5±0.60years; body weight:66.4±2.02kg; height:175.0±0.1cm) and 23 non-trained individuals in the NTF (age:27.5±0.98years; body weight:76.8±2.56kg; height:174.0±0.1cm). The volunteers went to the biomechanical laboratory on two different days with a 24h interval between sessions (familiarization and data collection). The stretching and testing were performed on a designed equipment (Figure 1) to measure biomechanical variables (i.e. Torque, ROM, Maximal ROM-ROM_{Max}). The volunteers were positioned lay down with 140° of hip flexion and the knee was passively extended until the point of increased stiffness, defined as the ROM_{Max}. The torque corresponded was recorded (pre-test). Stretching: 6 series of 30s keeping the torque measured in the pre-test constant. Electromyography readings guaranteed the passivity of the stretching. To calculate ROM_{increase} each one of the trials was divided by the ROM_{Max} of that subject. A two-way (Group×Series) ANOVA with repeated-measures assessed ROM_{increase} values (STATISTICA 7.0). When necessary, a post hoc Tukey HSD test was used. Alpha=0.05.

Results

With regard to the ROM_{increase}, the two-way ANOVA indicated a significant main effect for group ($F_{1,44}=9.717$, $p=0.0020$, power=0.80, $\eta_p^2=0.61$) and series ($F_{5,44}=7.846$, $p=0.0001$, power=0.72, $\eta_p^2=0.60$). A difference between groups became significant from the third trial with the TF exhibiting greater improvement than the NTF (Table 1).



Figure 1: The equipment and subject position during stretching.

SERIE	GROUP			
	TF		NTF	
	ROM _{increase} (%)	SD	ROM _{increase} (%)	SD
1	1.05	±0.03	1.03	±0.03
2	1.06	±0.03	1.05	±0.03
3*	1.07	±0.03	1.04	±0.04
4*	1.08	±0.03	1.05	±0.05
5*	1.09	±0.03	1.06	±0.05
6*	1.09	±0.03	1.06	±0.06

Table 1: Averaged ROM_{increase} between TF and NTF. * $p < 0.05$.

Discussion

The enhancement in the ROM_{increase} was greater in the TF than in the NTF, demonstrating greater accommodation from the third of the six series of the stretching. The acute increase of ROM after stretching may occur by mechanical alterations of the muscle-tendon unit (MTU) against stretching or by stretching tolerance change[3]. These results may be due to the varieties of the MTU passive structures (i.e., perimysium) and the passive joint structure[4] taking into consideration that more flexible subjects have lower stiffness than less flexible subjects[5] and that less stiff subjects showed higher viscoelastic response and increase in ROM during stretching[2].

References

1. Kocaja et al, Int J of Spo Med,12:285-289,1991.
2. Sobolewski et al, Mus & Ner,48:571-577,2013.
3. Weppler et al, J of Phy The,90:438-49,2010
4. Gajdosik et al, Clin Bio,16:87-101,2001.
5. Blazevich et al, J of App Phy,113:1446-1455,2012.



Confirmed Schedule

*The fourth Dance Science student and graduate networking and careers
day Friday 10th June*

Dear Barbara,

Many thanks for agreeing to present your research at our annual Dance Science Networking and Career's Day. I attach here a draft outline schedule of the day for your information.

Your session will be within the **Dance Science Research** section, which is currently scheduled for 14.45-15.45, you will be one of four speakers giving a brief 10-12 minute presentation. The four presentations will be followed by 15-20 minutes of q&a and discussion.

For your information, the intention of the day is twofold;

- To create a networking opportunity between like-minded individuals and forge connections between those in the early stages of a dance science career and with those with established positions in the field.
- To give soon-to-be graduates an idea of the routes into and out of Dance Science study.

Please let me know if you have any questions, require any specific equipment - beyond powerpoint presentation equipment such as projector, PC laptop and screen.

I look forward to meeting with you.

Many thanks,
Edel



27 – 31 of August 2016

The influence of menstrual cycle phase on flexibility and jump performance in dancers: interactions with MTC structural and functional characteristics

Pessali-Marques, B., Onambélé-Pearson, G.P., Burden, A., Cacalano, V. and McEwan, I.M.
Manchester Metropolitan University

INTRODUCTION: The menstrual cycle is a biological phenomenon with cyclic characteristics which occurs as a direct result of variations of blood concentrations of female hormones. It is composed by three phases: follicular, ovulatory and luteal (Bell et al., 2014). Connective tissue expresses hormone receptor transcripts for both oestrogen and progesterone; this may explain the differences in muscle-tendon complex (MTC) characteristics across menstrual cycle phases (MCP) previously identified. Studies have found modifications in joint laxity (Bell et al., 2014) tendon stiffness (Onambélé et al., 2007), muscle strength, proprioception and muscle activation patterns, in line with circulating levels of female hormones. However, there are two camps: studies showing difference in MTC characteristics and those not showing any in similar variables (Burgess et al., 2010); either way, the research is only spare and involves small numbers for the majority of the time.

If the presence of relatively high levels of oestrogen and/or progesterone were associated with decreased stiffness of ligamentous tissues, this reduction would increase initial muscle shortening velocity, the degree of muscle shortening, the muscle fascicle pennation angle at rest and during contraction, thus ultimately affecting force-production capacity. In addition, MTC stiffness is known to be integrated by the central nervous system, and the sensation of pain during the stretches, controlled by mechanoreceptors, is influenced by stiffness. This way, a reduced stiffness would lend itself to greater tendon deformation for equivalent forces (Onambélé et al., 2007), reaching a greater range of motion.

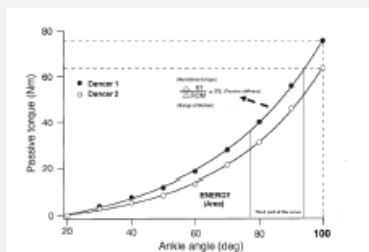

Figure 1. Passive stiffness was defined as the change in resistance torque (RT) divided by the change in range of motion (ROM) Dancer 1 needs greater passive torque to move the limb and achieve the same ROM as dancer 2, however, he is able to absorb more energy that could be used in jumps (Pessali-Marques, 2016).

AIM: Considering that flexibility and Jumping abilities could be influenced by MTC stiffness (Brughelli and Cronin, 2008), and MTC stiffness could be influenced by key menstrual cycle hormones, it is therefore necessary to determine if the different MCP could affect performance in Jumps and flexibility in dancers. Moreover, highlighting any interaction between MTC structural and functional characteristics, against the MCP, will help and/or predict any modifications in dance performance. It would also be timely to determine whether different levels of dancers are equally affected by the endocrine fluctuations induced through the MCP.



Figure 2. Jump and flexibility capabilities are prerequisites for numerous dance steps and as such are crucial for dancers' performance. (Credits: Luiza Castilho; Photo: Mario Veloso)

Study 1: Influence of MCP on Jump and flexibility performance in female taking and non-taking contraceptive pills.

Study 2: Influence of MCP on the response of MTC to stretch training in female taking and non-taking pills.

Study 3: Comparison of the MTC structural and functional characteristics between elite and student dancers and non-dancers.

Study 4: Influence of stretching in the performance of Jump and active flexibility in student-dancers, elite-dancers and non-dancers.

METHODS: The Manchester Metropolitan University Exercise and Sports Science Sub-Committee granted the ethical approval by the number 22.12.16 (ii). The groups will be composed of female non-dancers, professional and student dancers. The sample size is 21 volunteers in each group (effect size=0.8, power=0.96 and $\alpha=0.05$). The participants will be informed about all procedures and will sign the consent form. They will be tested on four separate days. The first day will be the familiarization, followed by follicular, ovulatory and luteal phases. Forms will be filled to characterize the participants' (personal information, injuries and exercise practiced). All the procedures will be done in the same order described above.

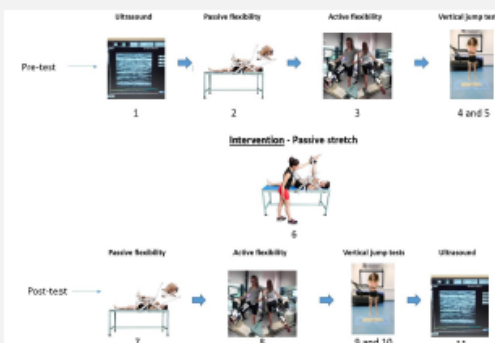

Figure 3. Illustrative images of the tests.

Vanipuncture: 6 ml of blood of the forearm veins for the concentration of hormones measurement.

Anthropometry and ultrasound images: body weight, height and percentage of fat, circumferences and length of the segments. Ultrasound images of the muscle tendon-unit of the hamstring muscle.

Passive flexibility: laid down with the arm of the equipment attached to the ankle. The researcher will move the equipment arm slowly (6°/s) to stretch the hamstrings muscles until the maximum tolerated by the volunteer. They will press in a control when they start to feel the stretching, 6 trials will be done.

Active flexibility: standing in vertical position with parallel feet, one ankle attached at the equipment arm. Then, 3 trials of flexion and extension of the hip will be done.

Vertical Jumps: countermovement jump and squat jump above a force platform, 3 trials of each jump will be done.

Intervention: 4 series of stretching for 30 seconds will be done in the same position and equipment used to measure the passive flexibility.

All tests will be recorded (3D analyses) to mechanical analyses of movements and the electromyography of the agonists and antagonists of each movement will be done.

References

- Bell, D., Blackburn, J., Harkney, A., Marshall, S., Beutler, A. and Padua, D. (2014) 'Jump-landing biomechanics and knee-laxity change across the menstrual cycle in women with anterior cruciate ligament reconstruction.' *Journal of Athletic Training*, 49
- Brughelli, M. and Cronin, J. (2008) 'A review of research on the mechanical stiffness in running and jumping: methodology and implications.' *Scandinavian Journal of Medicine and Science in Sports*, 18(4)
- Burgess, K. E., Pearson, S. J. and Onambélé, G. L. (2010) 'Deltoid Tendon Properties With Fluctuating Menstrual Cycle Hormones.' *Journal of Strength & Conditioning Research*, 24(8)
- Dichals, J., Lamberts, D. and Pousson, J. V. H. M. (2007) 'Changes in muscle and joint elasticity following long-term strength training in old age.' *European Journal of Applied Physiology*, 100
- Onambélé, G., Burgess, K. and Pearson, S. (2007) 'Gender-Specific In Vivo Measurement of the Structural and Mechanical Properties of the Human Deltoid Tendon.' *Journal of orthopaedic research*.

A COMPARISON OF DIFFERENT EQUIPMENT USED TO MEASURE AND TRAIN FLEXIBILITY

Bárbara Pessali Marques¹.

¹ - Manchester Metropolitan University; Doctoral researcher; BR-UK Dance Medicine & Science Network.

Email: b.pessali-marques@mmu.ac.uk.

Abstract

Flexibility is the capacity of a muscle to reach a range of motion (ROM) in a joint. However, the measurement of the ROM does not explain the behaviour of the muscle tendon unit (MTU) when stretched. Therefore, it is necessary to consider other parameters such as time and applied tension, beyond the ROM, to analyse the behaviour of the MTU after a stretching exercise. Considering the lack of equipment that could measure the described biomechanical and sensory variables to understand the MTU behaviour during the stretch, especially in flexibility trained populations such as dancers, the aim of this study was to analyse the potentials and limitations of the equipment used in previous researches and the Flexibility Test Equipment. A survey of the equipment already existing in the literature was performed and compared with the Flexibility Test Equipment. Then, the potentials and limitations regarding the volunteer positioning and variable measurements were analysed and compared. Six different pieces of equipment were found in the literature to measure flexibility from 1996 to 2014. We concluded that the The Flexibility Test Equipment is the only equipment able to measure all the biomechanical and sensory variables that are necessary for the multidimensional evaluation of flexibility and to understand MTU behaviour during stretching protocols.

Key words: Stretching; Muscle-tendon unit; Multidimensional; ROM; Flexibility test.

Introduction

Flexibility is the capacity of a muscle to reach a range of motion (ROM) in a joint^{1,2}. The ROM is usually used to represent this capacity, which is commonly measured in degrees. However, the measurement of the ROM does not explain the behaviour of the muscle tendon unit (MTU) when stretched³. Recently, Weppier and Magnusson³ (2010) have highlighted the necessity of considering other parameters such as time and applied tension, beyond the ROM, to analyse the behaviour of the MTU after a stretching exercise.

The increase in the ROM may be explained by two properties of the muscle-tendon unit: the biomechanical and the sensory properties. The biomechanical property is related with the MTU adaptations and the viscoelastic and neuromuscular relaxation. The mechanical property may be represented in the Length vs Tension curve as a shift to the right after the stretching protocol, which may result in a greater ROM with the same applied torque. The sensory property is related to the modifications in the tolerance of stretching and may be represented by an increase in the ROM without any shift of the curve³.

The behaviour of the MTU during the stretching protocol may be explained by the viscous and elastic characteristics, which together make the muscle behave as a viscoelastic material^{4,5}. To understand

PROCEEDINGS OF EVENT

this behaviour, it is necessary to measure variables other than the ROM considering both the biomechanical and sensory properties.

The stress relaxation is the accommodation of MTU tissue, which is the difference in torque when an angle is reached and maintained constant per a determined time⁵. The creep is the increase in the angle when the torque is maintained constant⁶. The stiffness is the variation of torque divided by the variation of ROM obtained in the Length vs Tension curve. The slope in the curve represents this, while the area under the curve represents energy. This refers to the potential energy stored by the muscle during the stretch. The first sensation of stretch is classed as the beginning of the stretch, which happens when the participant feels a tension in the muscle. Maximal discomfort tolerated is commonly used as the end of stretching, or maximal ROM point⁶.

Considering the lack of equipment that could measure the described biomechanical and sensory variables to understand the MTU behaviour during the stretch, especially in trained in flexibility populations such as dancers, the aim of this study was to analyse the potentials and limitations of equipment used in research and the Flexibility Test Equipment developed in the Biomechanics Laboratory of the Excellence in Sports Centre at Physical Education, Physiotherapy and Occupational Therapy of Federal University of Minas Gerais, Belo Horizonte, Brazil.

Methods

A survey of the equipment already existing in the literature was completed and compared with the Flexibility Test Equipment. Following this, the potentials and limitations regarding the volunteer positioning, and variables measurements were analysed and compared.

Results and Discussion

Six different pieces of equipment were found in the literature to measure flexibility. The pieces of equipment which have been used from 1996 to 2014 are presented in Figure 1.



Figure 1. Equipment used by Burke et al. (2000), Chagas et al. (2008), Magnusson et al. (1996) and Magnusson et al. (1998), Cabido et al. (2014), Chan et al. (2001), Blackburn et al. (2004), respectively.

As can be seen in image 1 (Figure 1), Burke et al.⁷ (2000) have performed the stretching through the flexion of the hip with the knee extended. This positioning allows pelvic movement and the hip retroversion may be confused with training effects. Moreover, the lower limbs, both the stretched and the non-stretched, were not properly attached to the equipment, which may have allowed other accessory movements and could be confused with flexibility improvements. Furthermore, this equipment did not allow measurements of the resistance torque nor the first sensation of stretch.

The image 2 (Figure 1) is from Chagas et al.⁸ (2008). They have used an apparatus in which the positioning of the participants was well established. The volunteer was better fixed to the equipment using straps with the hip flexed 90 degrees, thus the knee was passively extended. These adjustments have minimized accessories and pelvic movements, however, not all flexibility parameters were accessed. The torque and the first sensation of stretch were done. Furthermore, the maximum ROM measured by the equipment excludes the evaluation of trained in flexibility volunteers, since the maximum ROM was the knee extension with the hip flexed at 90 °.

Magnusson et al.⁹ (1996) and Magnusson et al.¹⁰ (1998) (image 3 – Figure 1) have also taken care of the participants' positioning with straps. Besides the fact that the maximum measurable ROM was greater, once the participants were sat and the thigh was flexed 45 degrees from the horizontal axis, the evaluation of trained in flexibility participants was still inappropriate. Both ROM and resistance torque were measured, but not the first sensation of stretch.

PROCEEDINGS OF EVENT

Image 4 (Figure 1) shows Cabido et al.¹¹ (2014) equipment. They have used a device that was able to measure all parameters for a multidimensional assessment of flexibility, ROM, resistance torque and first sensation of stretch, however, this equipment remained restricted to flexible people, allowing research only with those untrained in flexibility.

Chan et al.¹² (2001) have used a device in which the volunteer remained lying (image 5 - Figure 1). The ROM and resistance torque were accessed but not the first sensation of stretch. The volunteer was well positioned and strapped in the equipment avoiding any accessory pelvic movement. The stretching was performed by passive extension of the knees, however, the maximum measurable ROM was the full knee extension with the hip flexed 90°.

The equipment showed in the image 6 (Figure 1) was used by Blackburn et al.¹³ (2004), and it only evaluates the active ROM of knee extension, remaining with all the inability to measure the flexibility as a multi-dimensional capability as previously reported.

The Flexibility Test Equipment (Figure 2) allows the measurement of the right and left lower limbs separately during the passive knee extension with the participant lying supine on the equipment. Each one of the arms has two segments, one aligned to the calf and another aligned to the thigh. Together, these segments allow the movement and measurement of the hip and knee joints angles. When laying supine, the segment of hip flexion allows the positioning from 0° (thigh parallel to the table and floor) to 160° of hip flexion. The segment of knee extension allows the positioning from 30° to 180° (knee completely extended). It is possible to establish and fix the hip segment angle between these freedom angles and measure the knee segment ROM, once the knee is free to be extended and to stretch the volunteer until the maximal knee extension (180°).



Figure 2. Flexibility Test Equipment.

INTERNATIONAL WORKSHOP BR-UK DANCE MEDICINE & SCIENCE NETWORK A

The knee extension ROM is recorded by potentiometers located in the rotation axis of the knee in the equipment. The angle speed of the equipment lever arm during the stretch is maintained constant in $5^{\circ}/s^{1/2}$ when the movement is passive. At the distal portion of the equipment segment was a load cell and its position is adjusted in the ankle of the participant according to individual leg size. To minimize compensatory movements in the contralateral lower limb, straps are used on the anterior superior iliac spines and distal third of the thigh. During the ROM measurements, a control is given to the volunteer that should press the button when the first sensation of stretch is perceived in the hamstring muscles.

The purpose of this equipment was to enable a multidimensional approach of flexibility and allow the evaluation of flexible participants through proper body positioning. This equipment follows all of the volunteer placement requirements. The measurement by passive knee extension and not by hip flexion decreases compensatory pelvic movements that can be confused with the real gain of ROM. Proper fixing of both lower limbs strapped in the equipment also decreases the compensatory movements during stretching. The equipment assesses all the necessary parameters for a multidimensional evaluation of flexibility: ROM, resistance torque and first sensation of stretch. It allows the positioning of the volunteers with the contralateral to the stretched limb in an elongated position, and finally, gives the possibility of increasing the hip flexion of the stretching limb from 90° to 160° of hip flexion, which enables the use of the equipment for all the populations from non-trained individuals to trained in flexibility athletes, as dancers, gymnasts and wrestlers.

Conclusion

In conclusion, we understand that the Flexibility Test Equipment is the only equipment found in the literature able to measure all the biomechanical and sensory variables that are necessary for the multidimensional evaluation of the flexibility and to understand the muscle-tendon unit behaviour during stretching protocols. The participant is positioned and fixed properly in the equipment avoiding any compensatory movements and the maximal ROM achieved allows the evaluation of individuals with low and high levels of flexibility.

Acknowledgements

I would like to thank CAPES Foundation and the Brazilian Government for financing this research.

References

PROCEEDINGS OF EVENT

- 1- Magnusson SP, Simonsen EB, Aagaard P, Boesen J, Johannsen F, Kjaer M. Determinants of musculoskeletal flexibility: viscoelastic properties, cross-sectional area, EMG and stretch tolerance. *Scandinavian Journal of Medicine & Science in Sports*. 1997;7(4):195-202.
- 2- Alencar TAM, Matias KFS. Princípios fisiológicos do aquecimento e alongamento muscular na atividade esportiva. *Revista Brasileira de Medicina do Esporte*. 2010;16(3):230-44.
- 3- Weppler CH, Magnusson SP. Increasing muscle extensibility: a matter of increasing length or modifying sensation? *Journal of Physical Therapy*. 2010;90(3):438-49.
- 4- Taylor DC, Brooks DE, Ryan JB. Viscoelastic characteristics of muscle: passive stretching versus muscular contractions. *Medicine & Science in Sports Exercise*. 1997;29(12):1619-24.
- 5- Magnusson SP, Simonsen EB, Aagaard P, Gleim GW, McHugh MP, Kjaer M. Viscoelastic response to repeated static stretching in the human hamstring muscle. *Scandinavian Journal of Medicine & Science in Sports*. 1995;5(6):342-7.
- 6- Cabido C, Bergamini JC, Andrade AG, Lima F, Menzel H, Chagas MH. Acute effect of constant torque and angle stretching on range of motion, muscle passive properties, and stretch discomfort perception. *The Journal of Strength & Conditioning Research*. 2014;4(28):1050-7.
- 7- Burke GB, Culligan CJ, Holt LE, Mackinnon NC. Equipment Designed to Simulate Proprioceptive Neuromuscular Facilitation Flexibility Training. *Journal of Strength and Conditioning Research*. 2000(8):135-9.
- 8- Chagas MH, Bhering EL, Bergamini JC, Menzel HJ. Comparação de Duas Diferentes Intensidades de Alongamento na Amplitude de Movimento. *Revista Brasileira de Medicina do Esporte*. 2008;14(2):99-103.
- 9- Magnusson SP, Simonsen EB, Aagaard P, Dyhre-Poulsen P, McHugh MP, Kjaer M. Mechanical and Physiological Responses to Stretching With and Without Preisometric Contraction in Human Skeletal Muscle. *Archives of Physical Medicine and Rehabilitation*. 1996(77):373-8.
- 10- Magnusson SP. Passive properties of human skeletal muscle during stretch maneuvers. A review. *Scandinavian Journal of Medicine Science and Sports*. 1998(8):65-77.
- 11- Chan SP, Hong Y, Robinson PD. Flexibility and passive resistance of the hamstrings of young adults using two different static stretching protocols. *Scandinavian Journal of Medicine Science and Sport*. 2001;11:81-6.
- 12- Blackburn JK, Padua DA, Reimann BL, Guskiewicz KM. The relationships between active extensibility, and passive and active stiffness of the knee flexors. *Journal of Electromyography and Kinesiology*. 2004;14(6):683-91.



COMPARISON OF THE SYMMETRY INDEX OF RANGE OF MOTION AND TORQUE IN DANCERS AND NON-DANCERS

Bárbara Pessali-Marques¹, Mauro Chagas², Christian Cabido³, Gustavo Peixoto², André Andrade², Islay McEwan¹

¹Manchester Metropolitan University, Crewe, Cheshire, United Kingdom

²Federal University of Minas Gerais, Belo Horizonte, Minas Gerais, Brazil

³Federal University of Maranhão, São Luis, Maranhão, Brazil

Comparison of the symmetry index of Range of Motion and Torque in dancers and non-dancers

[Author names & affiliations removed for blinded review]

Purpose:

A number of researchers have considered identification of injury risk factors in relation to bilateral asymmetries (BA). In football players, BA in strength measurements have been linked to injury risk. There is, however, a paucity of published research considering the relationship between BA flexibility and injury risk. The multi-dimensional response of the muscle-tendon unit to stretching may provide valuable insight into the injury risk of dancers. The aim of this study, therefore, was to compare the symmetry index of hamstring range of motion and torque between the lower limbs in dancers and non-dancers.

Methods:

Ethical approval (36424414.0.000.5149 – FUMG). Participants were 30 male volunteers with no current musculoskeletal injury; 15 dancers (Dancers Group-DG [age:21.5±0.60 years; body weight:66.4±2.02kg; height:175.0±0.1cm]) and 15 non-dancers (Non-Dancers group-NDG [age:27.5±0.98 years; body weight:76.8±2.56kg; height:174.0±0.1cm]). All participants attended a biomechanics laboratory on two different days with a 24h interval between sessions (familiarization and data collection). Passive stretching was performed using equipment designed to measure biomechanical variables (i.e. Torque, Maximal ROM-ROMMax). The volunteers were positioned in supine with 140° of hip flexion and the knee was passively extended 3 times until the point of increased stiffness, defined as the ROMMax, was reached. The torque corresponded was recorded and called TorqueMax. The symmetry index was calculated using the Sadeghi et al. equation [(left lower limb–right lower limb)/biggest value]x100. An independent t-test was used to determine whether there were any significant differences between the groups (SPSS 22.0). Alpha=0.05.

Results:

A significant difference for the ROMMax between the two groups was found (DG:9.92%±7.5, 1.69%-26.95%; NDG:5.01%±4.5, 0.91%-18.03%; P=0.02). No significant differences in the symmetry index were found between DG and NDG for the TorqueMax (DG: 17.15%±8.9; 2.55%-31.18%; NDG:17.71%±8.9, 4.92%-32.58%; P=0.82).

Conclusion:

Both groups demonstrated BA in TorqueMax and ROMMax between each participant's legs. Only ROMMax was significantly different between the two groups (DG>NDG). The motor demands associated with dance may increase the BA and the relationship between BA in dancers and injury risk requires further investigation.

Arts · Humanities · Social Sciences · Sciences
 tinyurl.com/mmuconf2017 #MMUPGC17

@MMUPgrConf
 MMUPgrConf
 pgrconference@mmu.ac.uk

'CHANGING LIVES'

22 February 2017



How to evaluate dancers' performance? The validation of a jump mat to be used in the field



Bárbara Pessali-Marques, Adrian Burden, Gladys Onambele-Pearson, Islay McEwan.



Comparison in jump height

Jump mat	Force plate	3D-analyses
34.15 (±1.11)	21.75 (±1.57)	21.44 (±1.18)

Average (± standard deviation) in cm.

Jump mat intra and inter reliability

CV Between days	2.93%
CV Within days	3.33%

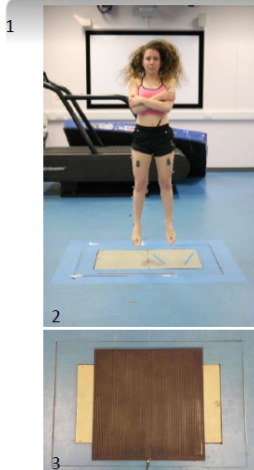

Jump mat vs. Force plate

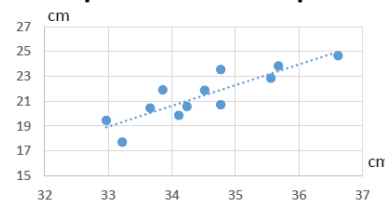

$R^2 = 0.7562$ $y = 1.6664x - 36.041$

Jump mat vs. 3D-analyses

Overestimation in the jump height of 12.99 ± 0.64 cm. (Bland-Altman analysis 95% limits of agreement ranging from 11.72 to 14.26 cm).

Scholarship student of Capes – Brazil. [9999.002176/2015-07](https://doi.org/10.9999/002176/2015-07)

1. Dancer: Luiza Castilho; Photo: Mario Veloso. 2. Dancer: Efimia Raouna; Photo 2 and 3: Bárbara Pessali-Marques. (Bárbara Pessali-Marques personal archive).

Oral presentation

Contact details of the 1st author (presenting at the conference)

Name: Bárbara Pessali-Marques

E-mail: b.pessali-marques@mmu.ac.uk

University: Manchester Metropolitan University

Faculty: MMU Cheshire

Department: Health, Exercise, and Active Living Research Centre, Department of Exercise and Sport Science

<p>The 9th MMU Postgraduate Research Conference 'CHANGING LIVES' Wednesday 22nd February 2017, 8.45–17.00 MMU Student Union (21 Higher Cambridge St, Manchester, M15 6AD, UK)</p>	
<p style="text-align: center;"><u>Abstract Submission Form</u></p>	
<p><u>Title</u></p>	<p>How to evaluate dancers' performance? The validation of a jump mat to be used in the field</p>
<p><u>Author(s)</u></p>	<p>Bárbara Pessali-Marques, Gladys Onambele-Pearson, Adrian Burden, Islay McEwan.</p>
<p><u>Abstract</u></p>	<p>Jump capability is crucial for dancers(1), however, when compared to physically active control participants, they do not jump significantly higher(2). Jump height can be increased with training(3), although there is evidence to suggest that dancers do not undertake sufficient supplementary training, or that the training may be ineffective(4). For good jump training results, jump height should be monitored. Force platforms and 3D-analysis are considered to be the gold standard for jump height measurements, however, they are expensive and their acquisition is not often possible for dance companies. An alternative is the jump mat that is cheaper, lighter, and considered to be a reliable method(5), despite accuracy levels being questionable. The aim of this study was to compare data from jump mat with that from force platform and 3D-analysis in order to validate and calculate its reliability. One participant performed 12 countermovement jumps in each situation: jump mat+3D-analysis; force platform+3D-analysis, and; jump mat+force platform+3D-analysis. The jump mat intra and inter reliability between 12 countermovement jumps was found to be very good (CV=2.93% and CV=3.33%, respectively). The correlation between jump mat and force plate was $r^2=0.76$ and the equation to predict force plate height from jump mat height was found to be $y=1.6664x-36.041$. The jump mat overestimate the jump height compared to the 3D-analyses in 12.99 ± 0.64cm. (Bland-Altman analysis 95% limits of agreement ranging from 11.72 to 14.26cm). Jump mat was found to be reliable and valid for field based monitoring of jump height. This may change dancers' lives, as better performance could lead to a more successful career.</p> <ol style="list-style-type: none">1. Kouterdakis Y, Stavropoulos-Kalinoglou A, Metsios G. The significance of muscular strength in dance. <i>Journal of Dancer Medicine and Science</i>. 2005;9(1):29-34.2. Harley Y. Quadriceps Strength and Jumping Efficiency in Dancers. <i>Journal of Dance and Medicine Science</i>. 2002;6:87-94.3. Crewther B, Cronin J, Keogh J. Possible Stimuli for Strength and Power Adaptation. <i>Sports Medicine</i>. 2005;35(11):967-89.4. Wyon M, Allen N, Angioi M, Nevill A, Twitchett E. Anthropometric factors affecting vertical jump height in ballet dancers. <i>Journal of Dance Medicine and Science</i>. 2006;10(3):106-10.5. Rogan S, Radlinger L, Imhasly C, Kneubuehler A, Hilfiker R. Validity study of a jump mat compared to the reference standard force plate. <i>Asian Journal of Sports Medicine</i>. 2015;6(4).

April 2017



DEVELOPMENT OF A DEVICE TO MEASURE AND TRAIN FLEXIBILITY

Bárbara Pessali-Marques; Gladys Onambélé-Pearson; Adrian Burden; Desney Richards; Islay McEwan.
1.Manchester Metropolitan University – Department of Exercise and Sport Science, United Kingdom.



Introduction

Flexibility is the capacity of a muscle to reach a range of motion in a joint (1, 2). The range of motion (ROM) is usually used to represent this capacity, which is commonly measured in degrees. The measurement of the ROM, however, does not explain the behaviour of the muscle-tendon unit (MTU) when stretched (3), therefore, it is necessary to measure variables other than the ROM considering the biomechanical and sensory properties; e.g. Maximum Torque, First Sensation of Stretch (Fig. 1), Stiffness, Energy (Fig. 2), Creep (Fig. 3), Stress Relaxation (Fig. 4).

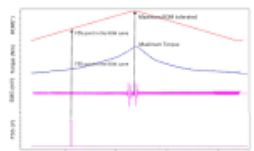

Figure 1 - Maximum ROM, Maximum torque and First sensation of stretch. (Pessali-Marques, 2014)

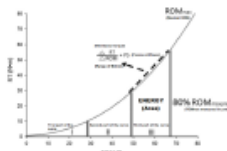

Figure 2 - Stiffness and Energy (Pessali-Marques, 2014)

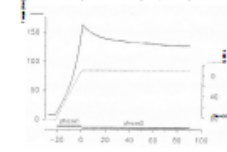

Figure 3 - Creep (adapted from Cabido et al 2014)

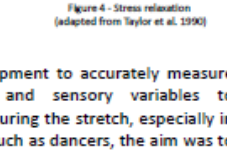

Figure 4 - Stress relaxation (adapted from Taylor et al. 1990)

Objective

Given the lack of adequate equipment to accurately measure the described biomechanical and sensory variables to understand the MTU behaviour during the stretch, especially in trained in flexibility populations such as dancers, the aim was to design and develop the Flexibility Equipment Test (FET).

1. Push button to control the ascend and descend of the lever.
2. The ankle support designed in a "U" shape to minimise hip external rotation.
3. Load cell (15 V - Líder Balanças - Brazil) to measure the MTU's resistance force against stretch.
4. Amplifier (RW-ST01 Strain Gauge Transducer - SWOWO).
5. Support for the thigh to avoid hyperextension of the knee.
6. Participants control to signal the FSS: a tension in the hamstrings.
7. Potentiometer (TT Electronics 5k0 1 watt wire wound pot) to record the ROM.
8. Analogical/digital converter (NI USB-6008 National Instruments).
9. Computer: DasyLab program 11.0 (Dasytec Daten System Technik GmbH, Germany).
10. Motor (Parvalux motor and right angle gearbox).
11. Straps to fix the limb
12. Cushions for the neck and lumbar areas.
13. Adjustable sections according to participant's limb length.
14. Lever

Scholarship student of Capes – Brazil. 99999.002176/2015-07

Description

The first version of the Equipment for Flexibility Test (EFT) was developed in the Biomechanics Laboratory of the Excellence in Sports Centre at Federal University of Minas Gerais, Belo Horizonte, Brazil. Improvements were done by Bárbara Pessali Marques and Alexandre Barros at Bastidores Conditioning Centre, Belo Horizonte, Brazil. The third version, here presented, was refined at Manchester Metropolitan University.

The EFT is used to measure passive torque, passive ROM and FSS. It is used to test and to train the hamstrings flexibility through different stretching protocols. The equipment allows the measurement of the right and left lower limbs separately.

In the initial position, the hip is considered to be at 0° of flexion and can move in a range up to 180°. The lever's angular speed is maintained constantly at 5°/s (4) when the button is continuously pressed. For gravity correction, the weight of the participant's limb is measured at 0° of hip flexion in the horizontal position. Therefore, the maximum gravity effect torque (MaxGET) is computed using the formulae:

$$\text{Limb assisted by gravity reported torque} = \text{Measured torque} - (\text{MaxGET} * \sin(\text{angle}))$$

$$\text{Limb resisted by gravity reported torque} = \text{Measured torque} + (\text{MaxGET} * \sin(\text{angle}))$$

Conclusion

The EFT enables a multidimensional approach of flexibility measurement through proper body positioning. It is the only equipment found in the literature (5) able to measure all the biomechanical and sensory variables that are necessary for the multidimensional evaluation of the flexibility and to understand the MTU behaviour during stretch protocols.

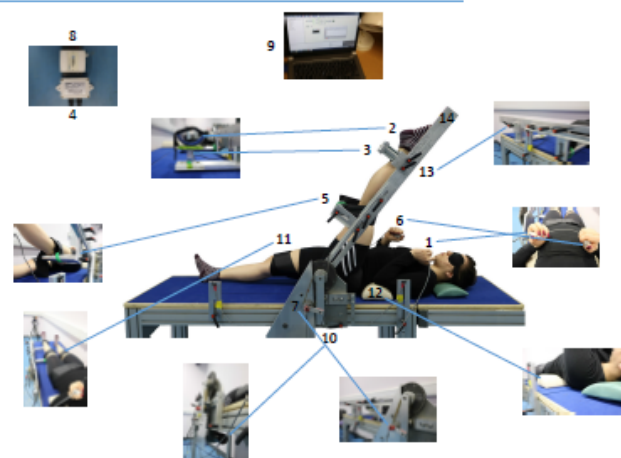

References

1. Magnusson SP, et al Scan J Med & Sci Spo. 1997;7(4):195-202.
2. Alencar TAM & Matias KFS. Rev Bras Med Esp. 2010;16(3):230-4.
3. Weppler CH, et al. J Phy Ther 2010;90(3):438-49.
4. Blackburn JK, et al. J Elec Kin. 2004;14(6):683-91.
5. Pessali-Marques, B. Rev Mov. 2016; 9(4):552-632



IADMS 28th Annual Conference Abstracts

Flexibility training for dancers

Bárbara Pessali-Marques, BA, MSc, Christopher Morse, PhD, Adrian Burden, PhD, Gladys Onambele, PhD

Manchester Metropolitan University, Crewe, Cheshire, United Kingdom

Participants: This session will be geared toward body conditioning professionals, dancers, movement scientists, teachers and clinicians who work with dancers aiming to increase their performance and decrease injury risks.

Purpose: The purpose is to educate attendees about the different types of stretching technique. Workshop leaders will demonstrate how to implement distinct stretching protocols according to the target to be reached; e.g. increase range of motion (ROM) without decreasing stiffness, increase ROM and decrease stiffness, and the importance and applicability of each protocol. The training loads: intensity of stretching, number of series and repetitions, and rest period will be analysed based on studies on the muscle-tendon unit (MTU) response to stretch-training. To understand the modifications in the MTU during the protocols, the biomechanical and sensory properties will be discussed according to the MTU's viscoelastic characteristic. At the conclusion of the session, participants should have a theoretical and practical understanding of how to stretch effectively, implement, monitor and progress a flexibility training through different stretching protocols, and how flexibility may affect other capabilities such as jumps.

Approach: Participants will be introduced to multiple stretch techniques Passive (with external support) or Active (antagonist muscle performing the stretching), Static (constant angle and constant torque) or Dynamic (ballistic). In addition, the neuromuscular proprioceptive facilitation and the use of mechanoreceptors to facilitate the stretch will be discussed. Participants will learn how to use the Visual Analogue Scale to (a) control the intensity of training, and (b) guarantee appropriate positioning to facilitate proper stretch execution. Participants will individually go through all the protocols. The session will utilize ropes, pillows, and elastic bands as auxiliary equipment. Participants should wear workout clothes.

Relevance: Flexibility is the capacity of reaching a determinate ROM. However, the isolated ROM measurement does not suffice to increase our understanding of the MTU behaviour after stretching protocols. Stiffness, for example, is an additional variable that is potentially modifiable with stretching, which also influence other capabilities such as jumps. Thus, it is important to know how to improve flexibility but also how flexibility may affect other crucial capabilities for dancers.

Pain sensitivity and tolerance: preliminary results between dancers and non-dancers

Bárbara Pessali-Marques, BA, MSc, Marie Chollier, BA, MSc, Adrian Burden, PhD, Christopher Morse, PhD, Gladys Onambebe, PhD
Manchester Metropolitan University, Crewe, Cheshire, United Kingdom

Purpose: Some studies investigating the mechanisms related to flexibility improvement after a stretching protocol found an increase in the range of motion without any modification in the biomechanical properties of the muscle-tendon unit. They justified this increase by the modification in the stretch tolerance to the pain felt during the stretching. However, the pain assessment remains a subjective experience; the inter- and intra-individual variability can be high due to habituation, psychological dimensions, and contextual factors. The aim of this study was to assess pain tolerance threshold between dancers and non-dancers.

Methods: Following ethics approval by the local committee, 6 dancers and 7 non-dancers, female aged [18;31], completed the “Self- Estimated Functional Inability because of Pain” (SEFIP) and the “Pain Anxiety Symptom Scale (PASS) Short Form 20” then performed the “Ice Water Test” (IWT). To standardise baseline conditions in terms of body temperature, each participant’s dominant forearm (up to the elbow) was immersed in a 35-38°C water container for 120 seconds; the dominant forearm was then immersed in a 0°C to -5°C ice water container for a maximum duration of 120 seconds.

Results: Preliminary results indicate that dancers show lower PASS scores (Total and subscales) but higher SEFIP scores (related mostly to current injury). IWT test duration was longer and rated as less painful in dancers.

Conclusion: Given the small sample (ongoing data collection) parametric tests cannot be performed, however descriptive findings are promising in assessing pain profile combining coping strategy and physiological sensitivity. Indeed, the elaboration of such pain profiling could have direct implications on training planning, may decrease the likelihood of injury, and influence rehabilitation protocols. Future work should further focus on any link between self-awareness of bodily triggers of pain sensation and coping strategies.

Appendix A – Grand jeté and sissone



Grand jeté a la seconde



Sissone



Grand Jeté

Appendix B – Développé and grand battement



Développé

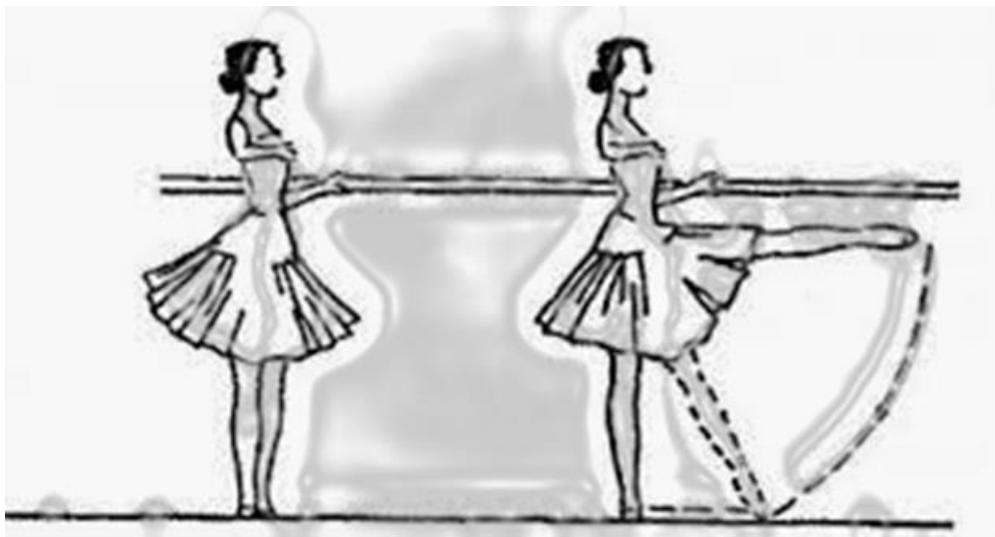

Grand battement



Both can be done devant, a la seconde and derriere

Appendix C – Plié



Plié

Appendix D – Developed worksheets

a) Calibration Worksheet

The screenshot displays a software interface for a calibration worksheet. The main workspace contains a central block diagram with the following components:

- Digital Me00**: A module with two black rectangular outputs.
- Digital Me01**: A module with two black rectangular outputs, labeled **ROM** and **TORQUE**.
- Task Panel**: A module with a red 'X' icon.
- Control and Signal Processing Modules**: A series of modules including **Control**, **Mathematics**, **Statistics**, **Signal Analysis**, **Display**, **Files**, **Data Reduction**, **Network**, **Special**, and **Add-On Modules**.
- Recorder00**: A data recorder window showing a plot with a single data point at approximately 16.58 s. The Y-axis ranges from -5.0 to 5.0. The X-axis ranges from 0 to 30 s.
- Recorder01**: A data recorder window showing a plot with a single data point at approximately 15.42 s. The Y-axis ranges from -25 to 300. The X-axis ranges from 0.00 to 1.00 min:s.
- Recorder02**: A data recorder window showing a plot with a single data point at approximately 15.42 s. The Y-axis ranges from -5.0 to 5.0. The X-axis ranges from 0 to 30 s.

The interface includes a menu bar (File, Edit, Modules, Measurement, View, Tools, Options, Window, Help) and a toolbar. The 'Modules' list on the left side is as follows:

- Modules
- Inputs/Outputs
- Trigger Functions
- Mathematics
- Statistics
- Signal Analysis
- Control
- Display
- Files
- Data Reduction
- Network
- Special
- Add-On Modules

The status bar at the bottom right shows the file name 'DASYLab11-Net - CALIBRATION.DSB - [Worksheet]' and the page number '154437'.

b) Left and right limb test Worksheet

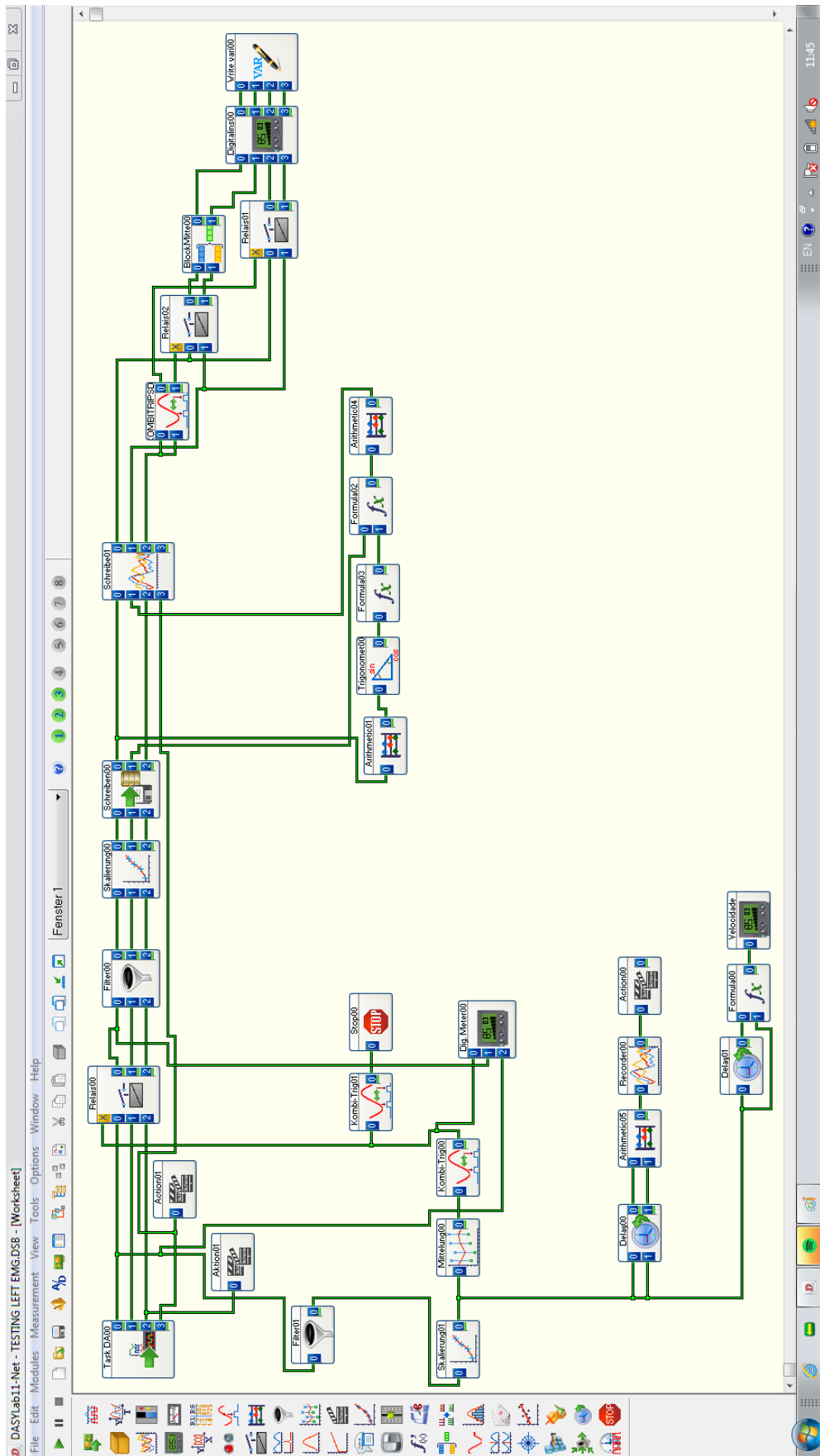

c) Right and left limb training worksheet

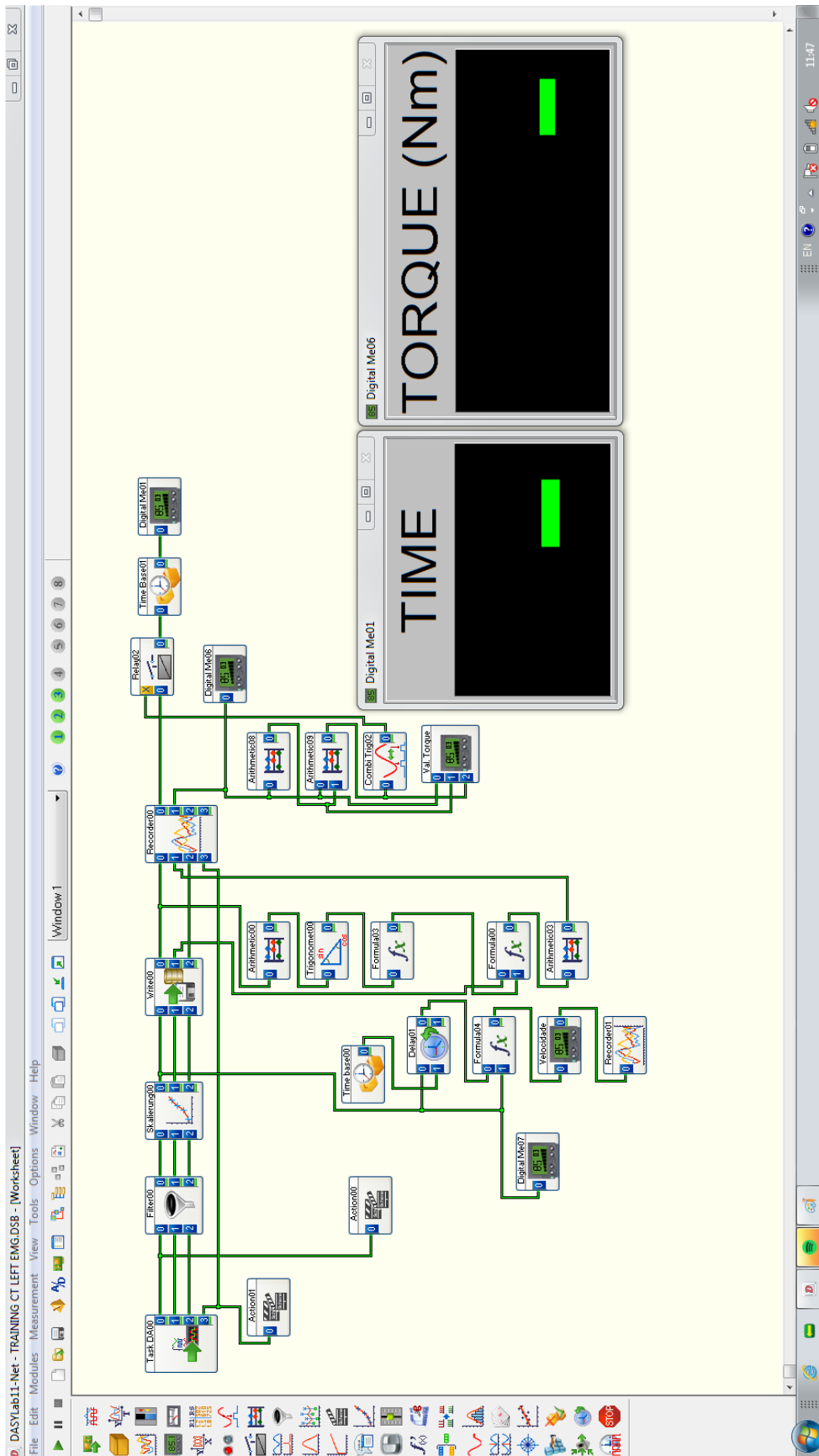

d) Data reading worksheet

The screenshot displays a LabVIEW data reading worksheet. The main workspace contains a block diagram with several modules: 'ROM', 'Torque', 'FSS (Torque)', 'FSS (ROM)', and 'Dig. Meter02'. A 'Schreiber01' window shows cursor data for 'Forca' with values: Y: 15.49, I2: 15.49, dt: 0.089. A 'Schreiber00' window shows a plot of 'ADM', 'EMG-m. ischiocruralii', and 'PSD'. A 'Modules' navigator is on the left, and a system tray with '1603:53' is at the bottom right.

e) Energy and Stiffness calculation worksheet

The screenshot displays a LabVIEW interface for an "ENERGY AND STIFFNESS" calculation worksheet. The main workspace contains a complex block diagram with the following components:

- Input/Output:** An "INBOX" module at the bottom left and an "ACTIVITY" module at the bottom right.
- Mathematical Operations:** Multiple "Form" blocks (containing $f(x)$), "Sum" blocks, and "Product" blocks.
- Data Handling:** "Write Array" and "Read Array" blocks for data storage and retrieval.
- Signal Processing:** "Derivative" and "Integral" blocks for calculating rates of change and accumulation.
- Control and Logic:** "Case" and "Select" blocks for conditional execution.
- Display and Monitoring:** A "Recorder" window on the left shows a graph of displacement (y-axis, -25 to 200) over time (x-axis, 0.00 to 1.00 min.s). On the right, a panel contains eight digital readout (DRO) displays: ENERGY, ENERGY II, ENERGY III, TOTAL ENERGY, STIFFNESS, STIFFNESS II, STIFFNESS III, and TOTAL STIFFNESS.

The interface includes a menu bar (File, Edit, Modules, Measurement, View, Tools, Options, Window, Help), a toolbar, and a module palette at the bottom with categories like Inputs/Outputs, Mathematics, Signal Analysis, and Data Reduction.

Appendix E – Literature review on studies comparing dancers and non-dancers

A Test of Objectification Theory in Former Dancers and Non-Dancers	Marika Tiggemann, Amy Slater, 2001	50 former students of classical ballet and 51 undergraduate psychology students	to test the complete model proposed in objectification theory as it applies to disordered eating.	It was found, as predicted, that former dancers scored more highly on self-objectification, self-surveillance, and disordered eating, with the differences in disordered eating, accounted for by the objectification measures.
Sources of Disordered Eating Patterns Between Ballet Dancers and Non-dancers	Anshel, Mark H. 2004	Australian adolescent ballet dancers and non-dancers.	To compare selected psycho-behavioural characteristics linked to disordered eating patterns.	Ballet dancers were more at risk for developing eating disorders than non-dancers and that dancers presented greater weight preoccupation, body dissatisfaction, and perfectionism than non-dancers.
Personality differences between young dancers and non-dancers	Frank C. Bakker 1988	dancers aged 15 or 16 years and children of the same age	Leisure activities, interests and personality traits were assessed by means of a number of questionnaires.	With respect to physical self-concept and self-esteem, dancers had less favourable attitudes and less self-esteem and were significantly more introverted than non-dancers.
An evaluation of differences in hip external rotation strength and range of motion between female dancers and nondancers	A Gupta, B Fernihough, G Bailey, P Bombeck, A Clarke, D Hopper. 2004	34 dancers and 37 non-dancers	To evaluate the differences in hip external rotation (ER) strength and inner, outer, and total hip ER range of motion (ROM) between dancers and non-dancers	Ballet dancers have greater inner range, angle specific strength and inner range ER ROM.
A comparison of actual-ideal weight discrepancy, body appreciation, and media influence between street-dancers and non-dancers	Viren Swami, Martin J. Tovée	83 street-dancers and 84 non-dancers	Body image was examined among individuals involved in street-dancing and an age-matched comparison of non-dancers.	No significant difference between-group difference in actual-ideal weight discrepancy, although street-dancers had significantly higher body appreciation than non-dancers.
Coordination modes in sensorimotor synchronization of whole-body movement: A study of street dancers and non-dancers	Akito Miura	dancers and non-dancers	The study investigated whole-body sensorimotor synchronization (SMS) in street dancers and non-dancers.	Street dancers have superior whole-body SMS ability.

Mother-daughter differences in menarcheal age in adolescent girls attending national dance company schools and non-dancers	J. Brooks-Gunn Michelle P. Warren 2009	350 adolescent dancers and non-dancers and their mothers were surveyed	To examine the possible differential influence of heredity and environmental factors on menarcheal age	The dancers had a later age of menarche than did the comparison group; their mothers did not differ with respect to menarcheal age
Action-perception coordination dynamics of whole-body rhythmic movement instance: A comparison study of street dancers and non-dancers	Akito Miuraab Kazutoshi Kudoa Kimitaka Nakazawaa	Nine skilled street dancers and 9 novice controls	The action-perception coordination in street dancers and non-dancers through knee extension/flexion on the beat were analysed.	dancers were able to perform up-on-the-beat at higher movement frequencies than non-dancers. This suggests that dynamical properties may differ between Dancers and Non-dancers.
Toe Flexor Forces in Dancers and Non-Dancers	Aneel Nihal, Jeffrey Goldstein, Judith Haas, Rudi Hiebert, Frederick J. Kummer, Marijeanne Liederbach, Elly Trepman	24 dancers and 29 non-dancers	Toe flexor force (hallux and second toe) was determined in the right and left feet	For the hallux and second toe combined (all trials combined), average toe flexor force was slightly greater for dancers than non-dancers
Bone Mineral Density Differences between Adolescent Dancers and Non-exercising Adolescent Females	William W.K.I., Margaret W.N.Wong, Ivy Y.L.Lam 2005	35 full-time collegiate dance students. 35 same age non-exercising controls.	To compare the bone mineral density (BMD) of the axial and appendicular to assess the impact of weight-bearing exercises and menstrual status on BMD	Dancers undergoing regular intensive weight-bearing exercises have higher BMD in the axial and appendicular skeleton as compared to non-dancers.
“Flash” dance: How speed modulates perceived duration in dancers and non-dancers	Helena Sgouramania ArgiroVatakis 2014	Dancers and non-dancers	Investigating the effects of speed and spatiotemporal experience in time estimation	Fast stimuli attracted attention and led to a contraction of perceived elapsed time Dancers were significantly less variable in their time estimates
Dancers entrain more effectively than non-dancers to another actor’s movements	Auriel Washburn, Mariana DeMarco. Simon de Vries, Kris	Thirty-five participants (16 female, 19 male) non-dancers, thirty-five (31 female, 4 male) dancers	to investigate whether trained dancers would be better able to coordinate with a partner performing	dancers consistently displayed higher levels of coordination with the confederate at both short and long time scales. These findings demonstrate that the visual-motor coordination capabilities of trained dancers allow them to better

	Ariyabuddhiphongs, R. C. Schmidt, Michael J. Richardson and Michael A. Riley, 2014		short sequences of dance-like movements than nondancers	synchronize with other individuals performing dance-like movements than non-dancers
Anthropometric Measurements of Young Ballet Dancers Examining Body Composition, Puberty, Flexibility, and Joint Range of Motion in Comparison with Non-Dancer Controls	Kadel, Nancy J., Donaldson-Fletcher, Emily A.; Gerberg, Lynda F., Micheli, Lyle J. 2005	43 female dance students from a school affiliated with a nationally known ballet company and 43 female age-matched students from local public schools	to compare body composition, sexual maturity, flexibility, and joint range of motion measurements between child ballet dancers and age-matched, non-dancer controls	child dancers were significantly leaner, more flexible, and sexually immature when compared to age-matched, non-dancer controls.
Exploring Active and Passive Contributors to Turnout in Dancers and Non-Dancers	Kristen Sutton-Traina, Jo Armour Smith, Danielle Nicole Jarvis, Szu-Ping Lee, Kornelia Kulig 2015	Twenty-three female dancers and 13 female non-dancers aged 18 to 30	To explore the relationship between standing active turnout and femoral bony morphology, hip passive ROM, and strength among dancers and non-dancers	Dancers demonstrated greater standing turnout, a significant difference for femoral version and were able to achieve greater peak force in turnout compared to non-dancers.
The Effect of Spinal and Pelvic Posture and Mobility on Back Pain in Young Dancers and Non-Dancers	McMeeken, Joan; Tully, Elizabeth; Natrass, Caroline; Stillman, Barry 2002	41 dances and 79 non-dancers	a questionnaire concerning the type and amount of regular activity and history of low back pain and computer-based analysis of videotape records examined sagittal standing posture and thoracolumbar flexion-extension mobility.	Dancers undertook more regular activity, were lighter, had straighter standing postures and greater thoracic and lumbar sagittal excursions, experienced significantly more back pain in the last year, and in earlier years, compared to non-dancers, but the relative incidence of back pain per hours of activity.
The Differences in Gait Pattern Between Dancers and Non-Dancers	C. -W. Lung, J. -S. Chern, L. -F. Hsieh and S. -W. Yang 2008	Thirteen students in dancing department and twenty age-matched normal healthy subjects	to investigate the differences in gait patterns between dancers and non-dancers and to explore the gait characteristics in dancers	dancers have greater medial shear force of the GRF, and decreased the CoP velocity during the pre-swing phase, delayed peak-CoP velocity occurrence during the mid-stance, and straighter CoP trajectory through the forefoot at push-off. The intense and demanding dancing activities change the

				walking pattern of dancers, which may lead to a higher chance of getting ankle sprain.
Hip and ankle range of motion and hip muscle strength in young female ballet dancers and controls.	K Bennell, K M Khan, B Matthews, M De Gruyter, E Cook, K Holzer, J D Wark	77 dancers and 49 controls	To compare the hip and ankle range of motion and hip muscle strength in 8–11-year-old novice female ballet dancers and controls.	Dancers had less ER and IR range than controls but greater ER: IR. dancers had greater non-hip ER. greater range of ankle dorsiflexion but similar calf muscle range, controls had stronger hip muscles except for hip abductor strength which was similar.
Comparison of Cervical and Ocular Vestibular Evoked Myogenic Potentials in Dancers and Non-Dancers	Sujeet Kumar Sinha, Vaishnavi Bohra, and Himanshu Kumar Sanju	8 trained in Indian classical dance, 8 non-dancers.	no significant difference between dancers and non-dancers for the latency and amplitude parameter for cVEMP and oVEMP, <i>i.e.</i> P13, N23 latency and P13-N23 complex amplitude and N10, P14 latency, N10-P14 complex amplitude respectively	The objective of the study was to assess the sacculocollic and otolith ocular pathway function using cervical vestibular evoked myogenic potentials (cVEMP) and ocular vestibular myogenic potentials (oVEMP) in dancers and non-dancers.
Media influence and body dissatisfaction in preadolescent ballet dancers and non-physically active girls	Amanda Nerini	67 non-professional ballet dancers ($M = 12.28$ years) and 68 non-physically active girls	The present study analysed media influences and body dissatisfaction in preadolescent non-professional female ballet dancers and non-physically active girls.	Amateur ballet dancers reported higher body dissatisfaction than non-physically active girls, higher athletic internalization
Satisfação com a imagem corporal e comportamentos de risco para transtornos alimentares em meninas praticantes e não praticantes de dança	Daniele Borba de Assunção Santiago Daniela Lopes dos Santos	11 dancers and 10 nondancers (public school) 9 dancers and 11 nondancers (private school) 9 dancers (dance school)	To investigate the relationship of dance and body image satisfaction and risk behaviours for eating disorders	It was found that the presence of risk behaviours for eating disorders and disorders related to body image distortion are present very early, not only in students who dance, but also in students in general.
Dance Experiences Associated with Body-Image and Personality among College Students: A Comparison of Dancers and Nondancers	Daniel D. Adame, Thomas C. Johnson, Steven P. Cole 1993	32 college students in dance classes and 26 students enrolled in a personal health class	To assess and Body-Image and Personality between dancers and non-dancers	dancers scored more internally on the locus of control and had lower Fitness Evaluation scores at pretest, but at post-test there were no significant differences between groups.

Toe Flexor Strength, Flexibility and Function and Flexor Hallucis Longus Tendon Morphology in Dancers and Non-Dancers	K. Michael Rowley, Danielle N. Jarvis, Toshiyuki Kurihara, Yu-Jen Chang, Abbigail L. Fietzer, Kornelia Kulig 2015	25 Dancers and 25 non-dancers	to characterize toe flexors in dancers by measuring strength, flexibility, function, and FHL tendon morphology.	dancers rely on toe flexors more than non-dancers to complete balance and heel raise tasks.
Biomechanical and Proprioceptive Differences during Drop Landings between Dancers and Non-dancers	Caroline J. Ketcham 2013	Eight collegiate dancers and seven collegiate controls	to determine if female dancers have differing kinematic and kinetic characteristics when landing from three heights (0.2, 0.5, and 0.8 m) both with and without vision compared to non-dancers.	Dancers significantly increased hip flexion when landing without vision compared to landing with vision, while non-dancers tended to stiffen up and reduced hip flexion, dancers utilize proprioceptive input more effectively as they adopted a hip strategy (flexion of the hips) to maintain stability.
The effects of delayed menarche in different contexts: Dance and non-dance students	J. Brooks-Gunn Michelle P. Warren 1985	276 non-dancers and 69 dancers	To explore how maturational timing relates to adaptation within different social contexts	Dance students weighed less and were leaner, had higher eating scores, and had lower family relationship and impulse control scores than the comparison sample.
Comparative study of anthropometric variables in female classical ballet dancers, volleyball players and physically active subjects	<i>Viviane Bortoluzzi Frasson, Fernando Diefenthaler, Marco Aurélio Vaz</i>	14 classical ballet dancers, 22 volleyball players and 13 physically active subjects	to compare anthropometric variables (body weight, height, and per cent body fat) and plantarflexion and dorsiflexion range of motion (ROM) between three different groups of women	Bodyweight and height were higher in volleyball players, followed by physically active women and ballet dancers. Per cent body fat was higher in physically active women. The three groups had similar ankle ROM and active dorsiflexion ROM, plantarflexion ROM was higher in ballet dancers.
Functional Characteristics of the Plantar Flexors in Ballet Dancer, Folk Dancer, and Non-Dancer Populations	Thomas, Kathleen S.; Parcell, Allen C 2004.	15 non-dancers, 15 folk dancers, and 15 ballet dancers	To compare values representing the strength, power, and endurance of the plantar flexors within a female population consisting of non-dancers, folk dancers and ballet dancers.	Based on the data, dancers as a general group are clearly a separate and distinct population from the normal, healthy, non-dancing females with regard to isometric strength, isokinetic strength, and the ability to produce work over a period of time.
Exploring the reciprocal modulation of time and space in dancers and non-dancers	Barbara Magnani Massimiliano Oliveri Francesca Frassinetti 2014	Dancers and non-dancers	explored whether time and space representations modulate each other in subjects that are trained to integrate time and space dimensions, i.e., professional dancers.	Dancers, differently from non-dancers, anticipated time in the Temporal task. However, both dancers and non-dancers were biased by the stimulus length when performing the Temporal task, while they were not biased by the stimulus duration when performing the Spatial task.

	Nigmatullina et al., 2013	In further support of differences between dancers and other sub-populations, a reduced capacity to maintain a determinate level of muscular co-contraction in the ankle was found in dancers compared to non-dancers, and a different response of the vestibular system between the two groups have been reported (Nigmatullina et al., 2013, Geertsen et al., 2013).		
	Geertsen et al., 2013			

Appendix F – Chapter 2 parametricity

Shapiro-Wilk parametricity test chapter 2. Variables in bold are non-normally distributed and variables in light are normally distributed.

Lower limb	Variable	Group	P
Dominant leg	ROM _{Max}	Non-dancers	.221
		Dancers	.434
	Torque _{Max}	Non-dancers	.853
		Dancers	.159
	FSS _{ROM}	Non-dancers	.166
		Dancers	.460
	FSS _{torque}	Non-dancers	.510
		Dancers	.070
	S _{MTU}	Non-dancers	.965
		Dancers	.917
	Energy	Non-dancers	.958
		Dancers	.854
Non-dominant leg	ROM _{Max}	Non-dancers	.886
		Dancers	.336
	Torque _{Max}	Non-dancers	.772
		Dancers	.240
	FSS _{ROM}	Non-dancers	.982
		Dancers	.550
	FSS _{torque}	Non-dancers	.359
		Dancers	.473
	S _{MTU}	Non-dancers	.944
		Dancers	.920
	Energy	Non-dancers	.941
		Dancers	.898
Dominant leg	Length	Non-dancers	.260
		Dancers	.049
	Width	Non-dancers	.019
		Dancers	.369
	CSA	Non-dancers	.141
		Dancers	.273
	Fat thickness	Non-dancers	.087
		Dancers	.119
	ST thickness	Non-dancers	.258
		Dancers	.735
	Total Lean thickness	Non-dancers	.180
		Dancers	.055
Non-dominant leg	Length	Non-dancers	.404
		Dancers	.266
	Width	Non-dancers	.070
		Dancers	.390
	CSA	Non-dancers	.238
		Dancers	.090
	Fat thickness	Non-dancers	.346
		Dancers	.607
	ST thickness	Non-dancers	.191
		Dancers	.007
	Total Lean thickness	Non-dancers	.521
		Dancers	.777
Dominant leg	CMJ Force _{peak}	Non-dancers	.001

		Dancers	.380
	CMJ Impulse	Non-dancers	.006
		Dancers	.088
Non-dominant leg	CMJ Force _{peak}	Non-dancers	.001
		Dancers	.602
	CMJ Impulse	Non-dancers	.615
		Dancers	.435
Combined	CMJ Take-off velocity	Non-dancers	.756
		Dancers	.818
	CMJ Jump height	Non-dancers	.502
		Dancers	.181
	CMJ total impulse	Non-dancers	.116
		Dancers	.240
CMJ total force _{peak}	Non-dancers	.002	
	Dancers	.042	
Dominant leg	SJ Force _{peak}	Non-dancers	.133
		Dancers	.108
	SJ Impulse	Non-dancers	.001
		Dancers	.728
Non-dominant leg	SJ Force _{peak}	Non-dancers	.013
		Dancers	.519
	SJ Impulse	Non-dancers	.001
		Dancers	.311
Combined	SJ Take-off velocity	Non-dancers	.323
		Dancers	.772
	SJ Jump height	Non-dancers	.958
		Dancers	.534
	SJ total impulse	Non-dancers	.110
Dancers		.097	
SJ total force _{peak}	Non-dancers	.054	
	Dancers	.098	
Dominant leg	EMG _{RF} CMJ	Non-dancers	.003
		Dancers	.899
Non-dominant leg	EMG _{RF} CMJ	Non-dancers	.005
		Dancers	.816
Dominant leg	EMG _{ST} CMJ	Non-dancers	.006
		Dancers	.037
Non-dominant leg	EMG _{ST} CMJ	Non-dancers	.020
		Dancers	.112
Dominant leg	EMG _{RF} SJ	Non-dancers	.014
		Dancers	.091
Non-dominant leg	EMG _{RF} SJ	Non-dancers	.720
		Dancers	.289
Dominant leg	EMG _{ST} SJ	Non-dancers	.540
		Dancers	.021
Non-dominant leg	EMG _{ST} SJ	Non-dancers	.015
		Dancers	.549
Combined	Total PASS	Non-dancers	.983
		Dancers	.484
	Mode Pass	Non-dancers	.049
		Dancers	.058
	Cognitive anxiety PASS	Non-dancers	.250
		Dancers	.078
	Escape PASS	Non-dancers	.232
		Dancers	.234
	Fear PASS	Non-dancers	.440
		Dancers	.359

Physiologic PASS	Non-dancers	.890	
	Dancers	.472	
Neck	Non-dancers	.000	
	Dancers	.000	
Upper back	Non-dancers	.000	
	Dancers	.000	
Elbows	Non-dancers	.000	
	Dancers	.000	
Lower back	Non-dancers	.000	
	Dancers	.001	
Hips	Non-dancers	.000	
	Dancers	.000	
Thighs (back)	Non-dancers	.000	
	Dancers	.000	
Shoulders	Non-dancers	.000	
	Dancers	.003	
Wrists/hands	Non-dancers	.000	
	Dancers	.000	
Thighs (front)	Non-dancers	.000	
	Dancers	.000	
Knees	Non-dancers	.000	
	Dancers	.000	
Shins	Non-dancers	.000	
	Dancers	.000	
Calves	Non-dancers	.000	
	Dancers	.000	
Ankles/feet	Non-dancers	.000	
	Dancers	.000	
Toes	Non-dancers	.000	
	Dancers	.000	
Other	Non-dancers	-	
	Dancers	-	
Total SEFIP	Non-dancers	.011	
	Dancers	.002	
Mode SEFIP	Non-dancers	.000	
	Dancers	.000	
IWT time tolerated	Non-dancers	.000	
	Dancers	.017	
VAS0s	Non-dancers	.336	
	Dancers	.846	
VAS15s	Non-dancers	.019	
	Dancers	.487	
VAS30s	Non-dancers	.013	
	Dancers	.122	
VAS45s	Non-dancers	.061	
	Dancers	.032	
VAS60s	Non-dancers	.568	
	Dancers	.453	
VAS75s	Non-dancers	.135	
	Dancers	.850	
VAS90s	Non-dancers	.182	
	Dancers	.272	
VAS105s	Non-dancers	.258	
	Dancers	.272	
VAS120s	Non-dancers	.061	
	Dancers	.577	
Combined	Oestrogen	Non-dancers	.001

		Dancers	.062
		Non-dancers	.223
	Progesterone	Dancers	.001
		Non-dancers	.001
	Relaxin	Dancers	.115
	Oestrogen	Both groups	.001
Combined	Progesterone	Both groups	.001
	Relaxin	Both groups	.001

Appendix G – Chapter 2 correlations

Correlation Flexibility – Hormonal concentration

		ROM _{Max}	Torque _{Max}	FSS _{ROM}	FSS _{torque}	SMTU	Energy	Oestrogen	Progesterone	Relaxin
ROM _{Max}	Correlation	1	.730**	.718**	.217*	.122	.484**	.297*	.234*	.084
	Sig. (1-tailed)		.000	.000	.048	.176	.000	.012	.038	.288
	N	60	60	60	60	60	60	58	58	46
Torque _{Max}	Correlation	.730**	1	.608**	.606**	.507**	.669**	.227*	.320**	.127
	Sig. (1-tailed)	.000		.000	.000	.000	.000	.043	.007	.201
	N	60	60	60	60	60	60	58	58	46
FSS _{ROM}	Correlation	.718**	.608**	1	.308**	.187	.408**	.390**	.137	.110
	Sig. (1-tailed)	.000	.000		.008	.076	.001	.001	.153	.234
	N	60	60	60	60	60	60	58	58	46
FSS _{torque}	Correlation	.217*	.606**	.308**	1	.559**	.476**	.105	.184	.025
	Sig. (1-tailed)	.048	.000	.008		.000	.000	.217	.083	.434
	N	60	60	60	60	60	60	58	58	46
SMTU	Correlation	.122	.507**	.187	.559**	1	.647**	.253*	.119	.063
	Sig. (1-tailed)	.176	.000	.076	.000		.000	.028	.187	.338
	N	60	60	60	60	60	60	58	58	46
Energy	Correlation	.484**	.669**	.408**	.476**	.647**	1	.378**	.249*	.133
	Sig. (1-tailed)	.000	.000	.001	.000	.000		.002	.030	.189
	N	60	60	60	60	60	60	58	58	46
Oestrogen	Correlation	.297*	.227*	.390**	.105	.253*	.378**	1.000	.347**	-.151
	Sig. (1-tailed)	.012	.043	.001	.217	.028	.002	.	.004	.159
	N	58	58	58	58	58	58	58	56	46

Progesterone	Correlation	.234*	.320**	.137	.184	.119	.249*	.347**	1.000	-.125
	Sig. (1-tailed)	.038	.007	.153	.083	.187	.030	.004	.	.210
	N	58	58	58	58	58	58	56	58	44
Relaxin	Correlation	.084	.127	.110	.025	.063	.133	-.151	-.125	1.000
	Sig. (1-tailed)	.288	.201	.234	.434	.338	.189	.159	.210	.
	N	46	46	46	46	46	46	46	44	46

Grey lines: Nonparametric correlation. White lines: Parametric correlation. Bolt numbers: Statistic significance. *: Correlation is significant at the 0.05 level (1-tailed). **: Correlation is significant at the 0.01 level (1-tailed). ROM: range of motion. Max: Maximal. S: Stiffness. MTU: Muscle tendon-unit. FSS: first sensation of stretch. Sig: significance. N: sample size.

		Impulse	Force _{Peak}	Take-off velocity	Jump height	Total Force	Total Impulse	Total Force _{Peak}	Oestrogen	Progesterone	Relaxin
Impulse	Correlation	1.000	.386**	.241	.241	.238	.701**	.536**	-.004	.154	.125
	Sig. (1-tailed)	.	.001	.099	.099	.103	.000	.001	.489	.124	.203
	N	60	60	30	30	30	30	30	58	58	46
Force_{Peak}	Correlation	.386**	1.000	-.274	-.274	.088	.456**	.827**	-.048	.034	.181
	Sig. (1-tailed)	.001	.	.072	.072	.321	.006	.000	.362	.401	.114
	N	60	60	30	30	30	30	30	58	58	46
Take-off velocity	Correlation	.232	-.253	1	.995**	.070	.338*	-.208	-.104	.046	-.214
	Sig. (1-tailed)	.109	.089		.000	.356	.034	.135	.296	.406	.163
	N	30	30	30	30	30	30	30	29	29	23
Jump height	Correlation	.221	-.245	.995**	1	.085	.361*	-.195	-.104	.046	-.214
	Sig. (1-tailed)	.120	.096	.000		.327	.025	.151	.296	.406	.163
	N	30	30	30	30	30	30	30	29	29	23
Total Force	Correlation	.300	.259	.070	.085	1	.348*	.177	.136	-.139	.262
	Sig. (1-tailed)	.054	.084	.356	.327		.030	.174	.241	.236	.114

	N	30	30	30	30	30	30	30	29	29	23
Total Impulse	Correlation	.558**	.311*	.338*	.361*	.348*	1	.407*	-.013	.240	.096
	Sig. (1-tailed)	.001	.047	.034	.025	.030		.013	.474	.104	.331
	N	30	30	30	30	30	30	30	29	29	23
Total Force_{peak}	Correlation	.536**	.827**	-.153	-.153	-.084	.530**	1.000	-.114	.199	.285
	Sig. (1-tailed)	.001	.000	.210	.210	.329	.001	.	.278	.150	.094
	N	30	30	30	30	30	30	30	29	29	23
Oestrogen	Correlation	-.004	-.048	-.104	-.104	.136	-.013	-.114	1.000	.347**	-.151
	Sig. (1-tailed)	.489	.362	.296	.296	.241	.474	.278	.	.004	.159
	N	58	58	29	29	29	29	29	58	56	46
Progesterone	Correlation	.154	.034	.046	.046	-.139	.240	.199	.347**	1.000	-.125
	Sig. (1-tailed)	.124	.401	.406	.406	.236	.104	.150	.004	.	.210
	N	58	58	29	29	29	29	29	56	58	44
Relaxin	Correlation	.125	.181	-.214	-.214	.262	.096	.285	-.151	-.125	1.000
	Sig. (1-tailed)	.203	.114	.163	.163	.114	.331	.094	.159	.210	.
	N	46	46	23	23	23	23	23	46	44	46

Grey lines: Nonparametric correlation. White lines: Parametric correlation. Bolt numbers: Statistic significance. *: Correlation is significant at the 0.05 level (1-tailed). **: Correlation is significant at the 0.01 level (1-tailed). Sig: significance. N: sample size.

		Impulse	Force _{Peak}	Take-off velocity	Jump height	Total Impulse	Total Force _{peak}	Oestrogen	Progesterone	Relaxin
Impulse	Correlation	1.000	.286*	.463**	.463**	.338*	-.032	.010	.064	.024
	Sig. (1-tailed)	.	.015	.006	.006	.036	.436	.470	.319	.436
	N	58	58	29	29	29	29	56	56	46
Force_{Peak}	Correlation	.286*	1.000	-.140	-.140	.600**	.739**	-.030	.102	.123
	Sig. (1-tailed)	.015	.	.235	.235	.000	.000	.414	.228	.207
	N	58	58	29	29	29	29	56	56	46

Take-off velocity	Correlation	.463**	-.140	1	.993**	.325*	-.133	-.201	.046	-.274
	Sig. (1-tailed)	.006	.235		.000	.042	.245	.153	.409	.103
	N	29	29	29	29	29	29	28	28	23
Jump height	Correlation	.463**	-.140	.993**	1	.330*	-.100	-.201	.046	-.274
	Sig. (1-tailed)	.006	.235	.000		.040	.302	.153	.409	.103
	N	29	29	29	29	29	29	28	28	23
Total Impulse	Correlation	.338*	.600**	.325*	.330*	1	.539**	-.092	.305	.046
	Sig. (1-tailed)	.036	.000	.042	.040		.001	.321	.057	.417
	N	29	29	29	29	29	29	28	28	23
Total Force _{peak}	Correlation	-.032	.739**	-.133	-.100	.539**	1	-.071	.028	.385*
	Sig. (1-tailed)	.436	.000	.245	.302	.001		.361	.444	.035
	N	29	29	29	29	29	29	28	28	23
Oestrogen	Correlation	.010	-.030	-.201	-.201	-.092	-.071	1.000	.347**	-.151
	Sig. (1-tailed)	.470	.414	.153	.153	.321	.361	.	.004	.159
	N	56	56	28	28	28	28	58	56	46
Progesterone	Correlation	.064	.102	.046	.046	.305	.028	.347**	1.000	-.125
	Sig. (1-tailed)	.319	.228	.409	.409	.057	.444	.004	.	.210
	N	56	56	28	28	28	28	56	58	44
Relaxin	Correlation	.024	.123	-.274	-.274	.046	.385*	-.151	-.125	1.000
	Sig. (1-tailed)	.436	.207	.103	.103	.417	.035	.159	.210	.
	N	46	46	23	23	23	23	46	44	46

Grey lines: Nonparametric correlation. White lines: Parametric correlation. Bolt numbers: Statistic significance. *: Correlation is significant at the 0.05 level (1-tailed). **: Correlation is significant at the 0.01 level (1-tailed). Sig: significance. N: sample size.

Correlation muscle structure – Hormonal concentration

		Muscle length	Muscle width	Muscle CSA	Fat thickness	St thickness	Lean	Oestrogen	Progesterone	Relaxin
Muscle length	Correlation	1	.102	.062	-.013	.261*	.196	-.070	.280*	-.149
	Sig. (1-tailed)		.226	.319	.462	.023	.069	.300	.051	.162
	N	60	57	60	59	59	59	58	58	46
Muscle width	Correlation	.102	1.000	.723**	.253*	.229*	.493**	.166	.156	.119
	Sig. (1-tailed)	.226	.	.000	.030	.045	.000	.114	.128	.224
	N	57	57	57	56	56	56	55	55	43
Muscle CSA	Correlation	.062	.723**	1	-.196	.445**	.580**	.177	.167	.041
	Sig. (1-tailed)	.319	.000		.068	.000	.000	.092	.105	.394
	N	60	57	60	59	59	59	58	58	46
Fat thickness	Correlation	-.013	.253*	-.196	1	.014	.043	.039	-.036	.185
	Sig. (1-tailed)	.462	.030	.068		.460	.373	.387	.395	.112
	N	59	56	59	59	59	59	57	57	45
ST thickness	Correlation	.261*	.229*	.445**	.014	1.000	.704**	-.021	.065	.030
	Sig. (1-tailed)	.023	.045	.000	.460	.	.000	.438	.315	.421
	N	59	56	59	59	59	59	57	57	45
Lean	Correlation	.196	.493**	.580**	.043	.704**	1	-.001	.117	-.072
	Sig. (1-tailed)	.069	.000	.000	.373	.000		.498	.193	.320
	N	59	56	59	59	59	59	57	57	45
Oestrogen	Correlation	-.070	.166	.177	.039	-.021	-.001	1.000	.347**	-.151
	Sig. (1-tailed)	.300	.114	.092	.387	.438	.498	.	.004	.159
	N	58	55	58	57	57	57	58	56	46
Progesterone	Correlation	.280*	.156	.167	-.036	.065	.117	.347**	1.000	-.125

	Sig. (1-tailed)	.017	.128	.105	.395	.315	.193	.004	.	.210
	N	58	55	58	57	57	57	56	58	44
Relaxin	Correlation	-.149	.119	.041	.185	.030	-.072	-.151	-.125	1.000
	Sig. (1-tailed)	.162	.224	.394	.112	.421	.320	.159	.210	.
	N	46	43	46	45	45	45	46	44	46

Grey lines: Nonparametric correlation. White lines: Parametric correlation. Bolt numbers: Statistic significance. *: Correlation is significant at the 0.05 level (1-tailed). **: Correlation is significant at the 0.01 level (1-tailed). D: dominant limb. nD: non-dominant limb. CSA: Cross-sectional area. ST: semitendinosus. Sig: significance. N: sample size.

Correlation pain tolerance – Hormonal concentration													
		Time tolerated	Total PASS	Mode PASS	PASS Anxiety	PASS Escape	PASS Fear	PASS Physio	Total SEFIP	Mode SEFIP	Oestrogen	Progesterone	Relaxin
Time tolerated	Correlation	1.000	.023	-.013	.166	-.146	.067	-.094	.058	.210	.081	-.240	.324
	Sig. (1-tailed)	.	.452	.473	.194	.224	.365	.313	.385	.142	.338	.105	.066
	N	30	29	29	29	29	29	29	28	28	29	29	23
Total PASS score	Correlation	.023	1	.894**	.917**	.892**	.954**	.948**	-.143	-.103	.134	.271	.073
	Sig. (1-tailed)	.452		.000	.000	.000	.000	.000	.235	.301	.249	.081	.374
	N	29	29	29	29	29	29	29	28	28	28	28	22
Mode PASS score	Correlation	-.013	.894**	1	.891**	.768**	.832**	.815**	-.215	-.143	-.078	.246	.114
	Sig. (1-tailed)	.473	.000		.000	.000	.000	.000	.136	.234	.347	.104	.307
	N	29	29	29	29	29	29	29	28	28	28	28	22
PASS Anxiety	Correlation	.166	.917**	.891**	1	.690**	.867**	.832**	-.197	-.026	.130	.244	.015
	Sig. (1-tailed)	.194	.000	.000		.000	.000	.000	.157	.448	.254	.106	.473

	N	29	29	29	29	29	29	29	28	28	28	28	22
PASS Escape	Correlation	-.146	.892**	.768**	.690**	1	.796**	.815**	-.103	-.190	.117	.362*	.084
	Sig. (1-tailed)	.224	.000	.000	.000		.000	.000	.302	.166	.277	.029	.354
	N	29	29	29	29	29	29	29	28	28	28	28	22
PASS Fear	Correlation	.067	.954**	.832**	.867**	.796**	1	.886**	-.087	-.069	.100	.286	.059
	Sig. (1-tailed)	.365	.000	.000	.000	.000		.000	.330	.364	.307	.070	.397
	N	29	29	29	29	29	29	29	28	28	28	28	22
PASS Physio	Correlation	-.094	.948**	.815**	.832**	.815**	.886**	1	-.123	-.112	.081	.160	.093
	Sig. (1-tailed)	.313	.000	.000	.000	.000	.000		.266	.285	.342	.208	.340
	N	29	29	29	29	29	29	29	28	28	28	28	22
Total SEFIP	Correlation	.058	-.143	-.215	-.197	-.103	-.087	-.123	1.000	.356*	-.012	.049	.082
	Sig. (1-tailed)	.385	.235	.136	.157	.302	.330	.266	.	.032	.477	.404	.362
	N	28	28	28	28	28	28	28	28	28	27	27	21
Mode SEFIP	Correlation	.210	-.103	-.143	-.026	-.190	-.069	-.112	.356*	1.000	.200	.000	-.014
	Sig. (1-tailed)	.142	.301	.234	.448	.166	.364	.285	.032	.	.159	.500	.477
	N	28	28	28	28	28	28	28	28	28	27	27	21
Oestrogen	Correlation	.081	.134	-.078	.130	.117	.100	.081	-.012	.200	1.000	.347**	-.151
	Sig. (1-tailed)	.338	.249	.347	.254	.277	.307	.342	.477	.159	.	.004	.159
	N	29	28	28	28	28	28	28	27	27	58	56	46
Progesterone	Correlation	-.240	.271	.246	.244	.362*	.286	.160	.049	.000	.347**	1.000	-.125
	Sig. (1-tailed)	.105	.081	.104	.106	.029	.070	.208	.404	.500	.004	.	.210
	N	29	28	28	28	28	28	28	27	27	56	58	44
Relaxin	Correlation	.324	.073	.114	.015	.084	.059	.093	.082	-.014	-.151	-.125	1.000
	Sig. (1-tailed)	.066	.374	.307	.473	.354	.397	.340	.362	.477	.159	.210	.

N	23	22	22	22	22	22	22	21	21	46	44	46
---	----	----	----	----	----	----	----	----	----	----	----	----

Grey lines: Nonparametric correlation. White lines: Parametric correlation. Bolt numbers: Statistic significance. *: Correlation is significant at the 0.05 level (1-tailed). **: Correlation is significant at the 0.01 level (1-tailed). SEFIP: Self-estimated functional inability because of pain. PASS: Pain anxiety symptom scale. Sig: significance. N: sample size.

		Correlation EMG – Hormonal concentration						
		CMJ EMG _{RF}	CMJ EMG _{ST}	SJ EMG _{RF}	SJ EMG _{ST}	Oestrogen	Progesterone	Relaxin
CMJ EMG _{RF}	Correlation	1.000	.285*	.650**	.160	-.164	-.199	-.133
	Sig. (1-tailed)	.	.025	.000	.153	.132	.093	.210
	N	48	48	44	43	48	46	39
CMJ EMG _{ST}	Correlation	.285*	1.000	.268*	.369**	.022	.059	-.236
	Sig. (1-tailed)	.025	.	.040	.007	.441	.347	.074
	N	48	48	44	43	48	46	39
SJ EMG _{RF}	Correlation	.650**	.268*	1.000	.290*	-.028	-.121	-.141
	Sig. (1-tailed)	.000	.040	.	.024	.425	.212	.193
	N	44	44	48	47	48	46	40
SJ EMG _{ST}	Correlation	.160	.369**	.290*	1.000	-.144	-.117	-.131
	Sig. (1-tailed)	.153	.007	.024	.	.167	.222	.211
	N	43	43	47	47	47	45	40
Oestrogen	Correlation	-.164	.022	-.028	-.144	1.000	.347**	-.151
	Sig. (1-tailed)	.132	.441	.425	.167	.	.004	.159
	N	48	48	48	47	58	56	46

Progesterone	Correlation	-.199	.059	-.121	-.117	.347**	1.000	-.125
	Sig. (1-tailed)	.093	.347	.212	.222	.004	.	.210
	N	46	46	46	45	56	58	44
Relaxin	Correlation	-.133	-.236	-.141	-.131	-.151	-.125	1.000
	Sig. (1-tailed)	.210	.074	.193	.211	.159	.210	.
	N	39	39	40	40	46	44	46

Grey lines: Nonparametric correlation. White lines: Parametric correlation. Bolt numbers: Statistic significance. *: Correlation is significant at the 0.05 level (1-tailed). **: Correlation is significant at the 0.01 level (1-tailed). SEFIP: Self-estimated functional inability because of pain. PASS: Pain anxiety symptom scale. Sig: significance. N: sample size.

Appendix H – Chapter 3 parametricity

Shapiro-Wilk parametricity test chapter 3. Variables in bold are non-normally distributed and variables in light are normally distributed.

Variable	Group	p
ΔROM_{Max}	Control	.506
	Training	.800
$\Delta Torque_{Max}$	Control	.735
	Training	.191
ΔFSS_{ROM}	Control	.924
	Training	.000
ΔFSS_{torque}	Control	.060
	Training	.032
ΔS_{MTU}	Control	.003
	Training	.124
$\Delta Energy$	Control	.029
	Training	.390
Pre - ROM_{Max}	Control	.412
	Training	.714
Post - ROM_{Max}	Control	.100
	Training	.898
Pre - $Torque_{Max}$	Control	.759
	Training	.360
Post - $Torque_{Max}$	Control	.881
	Training	.976
Pre - FSS_{ROM}	Control	.223
	Training	.002
Post - FSS_{ROM}	Control	.186
	Training	.971
Pre - FSS_{torque}	Control	.108
	Training	.649
Post - FSS_{torque}	Control	.449
	Training	.405
Pre - S_{MTU}	Control	.634
	Training	.922
Post - S_{MTU}	Control	.565
	Training	.478
Pre - Energy	Control	.490
	Training	.819
Post - Energy	Control	.591
	Training	.698
ΔCMJ Impulse	Control	.490
	Training	.691
ΔCMJ force _{peak}	Control	.952
	Training	.014
ΔCMJ total impulse	Both limbs	.381
ΔCMJ total $v_{take-off}$	Both limbs	.121
ΔCMJ jump height	Both limbs	.153

Δ CMJ total force _{peak}	Both limbs	.861
Δ SJ Impulse	Control	.239
	Training	.607
Δ SJ force _{peak}	Control	.598
	Training	.096
Δ SJ total impulse	Both limbs	.142
Δ SJ total v _{take-off}	Both limbs	.588
Δ SJ jump height	Both limbs	.694
Δ SJ total force _{peak}	Both limbs	.088
Pre – CMJ impulse	Control	.186
	Training	.167
Post – CMJ impulse	Control	.490
	Training	.691
Pre – CMJ force _{peak}	Control	.701
	Training	.774
Post – CMJ force _{peak}	Control	.952
	Training	.014
Pre – CMJ total impulse	Both limbs	.614
Post – CMJ total impulse	Both limbs	.381
Pre – CMJ v _{take-off}	Both limbs	.484
Post – CMJ v _{take-off}	Both limbs	.120
Pre – CMJ jump height	Both limbs	.441
Post – CMJ jump height	Both limbs	.153
Pre – CMJ total force _{peak}	Both limbs	.896
Post – CMJ Total force _{peak}	Both limbs	.861
Pre – SJ impulse	Control	.801
	Training	.201
Post – SJ impulse	Control	.607
	Training	.239
Pre – SJ force _{peak}	Control	.221
	Training	.875
Post – SJ force _{peak}	Control	.096
	Training	.598
Pre – SJ total impulse	Both limbs	.936
Post – SJ total impulse	Both limbs	.142
Pre – SJ v _{take-off}	Both limbs	.040
Post – SJ v _{take-off}	Both limbs	.588

Pre – SJ jump height	Both limbs	.050
Post – SJ jump height	Both limbs	.694
Pre – SJ total force _{peak}	Both limbs	.710
Post – SJ Total force _{peak}	Both limbs	.088
Oestrogen	Both limbs	.154
Progesterone	Both limbs	.007

Appendix I – Chapter 3 correlations

		Correlation Flexibility – Hormonal concentration							
		Δ ROM	Δ torque	Δ FSS _{ROM}	Δ FSS _{torque}	Δ S _{MTU}	Δ Energy	Oestrogen	Progesterone
Δ ROM	Correlation	1	.362*	-.029	-.238	.190	.288	.060	.293
	Sig. (1-tailed)		.025	.439	.102	.157	.062	.377	.065
	N	30	30	30	30	30	30	30	28
Δ torque	Correlation	.362*	1	.151	.255	-.272	-.288	-.129	.014
	Sig. (1-tailed)	.025		.213	.087	.073	.062	.248	.472
	N	30	30	30	30	30	30	30	28
Δ FSS _{ROM}	Correlation	.083	-.048	1.000	.564**	.135	.222	.021	-.241
	Sig. (1-tailed)	.331	.400	.	.001	.239	.119	.456	.108
	N	30	30	30	30	30	30	30	28
Δ FSS _{torque}	Correlation	-.181	.288	.564**	1.000	.180	.175	-.004	-.327*
	Sig. (1-tailed)	.169	.062	.001	.	.171	.178	.492	.045
	N	30	30	30	30	30	30	30	28
Δ S _{MTU}	Correlation	-.009	-.226	.135	.180	1.000	.802**	.472**	.286
	Sig. (1-tailed)	.481	.115	.239	.171	.	.000	.004	.070
	N	30	30	30	30	30	30	30	28
Δ Energy	Correlation	.111	-.185	.222	.175	.802**	1.000	.403*	.310
	Sig. (1-tailed)	.280	.163	.119	.178	.000	.	.014	.054
	N	30	30	30	30	30	30	30	28
Oestrogen	Correlation	.060	-.129	.021	-.004	.472**	.403*	1	.393*
	Sig. (1-tailed)	.377	.248	.456	.492	.004	.014		.019
	N	30	30	30	30	30	30	30	28

Progesterone	Correlation	.293	.014	-.241	-.327*	.286	.310	.393*	1.000
	Sig. (1-tailed)	.065	.472	.108	.045	.070	.054	.019	.
	N	28	28	28	28	28	28	28	28

Grey lines: Nonparametric correlation. White lines: Parametric correlation. Bolt numbers: Statistic significance. *: Correlation is significant at the 0.05 level (1-tailed). **: Correlation is significant at the 0.01 level (1-tailed). Δ : (Post-Pre)/Pre. ROM: range of motion. Max: Maximal. FSS: first sensation of stretch. Sig: significance.

		Δ impulse	Δ force _{peak}	Δ total impulse	Δ total v _{takeoff}	Δ total jump height	Δ total force _{peak}	Oestrogen	Progesterone
Δ impulse	Correlation	1	.326	.750**	.640*	.641*	.418	-.024	-.163
	Sig. (1-tailed)		.064	.004	.017	.017	.100	.457	.229
	N	23	23	11	11	11	11	23	23
Δ force _{peak}	Correlation	.326	1.000	.755**	.147	.147	.951**	-.016	-.391*
	Sig. (1-tailed)	.064	.	.002	.324	.324	.000	.471	.030
	N	23	24	12	12	12	12	24	24
Δ total impulse	Correlation	.750**	.755**	1	.388	.385	.819**	.022	-.476
	Sig. (1-tailed)	.004	.002		.106	.108	.001	.472	.059
	N	11	12	12	12	12	12	12	12
Δ total v _{takeoff}	Correlation	.640*	.147	.388	1	1.000**	.020	-.027	-.007
	Sig. (1-tailed)	.017	.324	.106		.000	.475	.466	.491
	N	11	12	12	12	12	12	12	12
Δ total jump height	Correlation	.641*	.147	.385	1.000**	1	.020	-.035	-.007
	Sig. (1-tailed)	.017	.324	.108	.000		.475	.457	.491
	N	11	12	12	12	12	12	12	12
Δ total force _{peak}	Correlation	.418	.951**	.819**	.020	.020	1	.074	-.406

	Sig. (1-tailed)	.100	.000	.001	.475	.475		.410	.095
	N	11	12	12	12	12	12	12	12
Oestrogen	Correlation	-.024	-.016	.022	-.027	-.035	.074	1	.560**
	Sig. (1-tailed)	.457	.471	.472	.466	.457	.410		.001
	N	23	24	12	12	12	12	30	28
Progesterone	Correlation	-.163	-.391*	-.476	-.007	-.007	-.406	.560**	1.000
	Sig. (1-tailed)	.229	.030	.059	.491	.491	.095	.001	.
	N	23	24	12	12	12	12	28	28

CMJ: countermovement jump. Grey lines: Nonparametric correlation. White lines: Parametric correlation. Bolt numbers: Statistic significance. *: Correlation is significant at the 0.05 level (1-tailed). **: Correlation is significant at the 0.01 level (1-tailed). Δ : (Post-Pre)/Pre. Sig: significance.

		Δ impulse	Δ force _{peak}	Δ total impulse	Δ total V _{takeoff}	Δ total jump height	Δ total force _{peak}	Oestrogen	Progesterone
Δ impulse	Correlation	1	.226	.490	.688**	.679*	-.482	-.071	-.112
	Sig. (1-tailed)		.144	.063	.010	.011	.066	.370	.302
	N	24	24	11	11	11	11	24	24
Δ force_{peak}	Correlation	.226	1	.203	-.089	-.065	.879**	.426*	.106
	Sig. (1-tailed)	.144		.253	.386	.416	.000	.015	.304
	N	24	26	13	13	13	13	26	26
Δ total impulse	Correlation	.490	.203	1	.525*	.516*	.143	-.174	-.775**
	Sig. (1-tailed)	.063	.253		.033	.036	.321	.285	.001
	N	11	13	13	13	13	13	13	13
Δ total V_{takeoff}	Correlation	.688**	-.089	.525*	1	.998**	-.287	-.168	-.033
	Sig. (1-tailed)	.010	.386	.033		.000	.171	.291	.457

	N	11	13	13	13	13	13	13	13
Δ total jump height	Correlation	.679*	-.065	.516*	.998**	1	-.265	-.142	-.033
	Sig. (1-tailed)	.011	.416	.036	.000		.191	.322	.457
	N	11	13	13	13	13	13	13	13
Δ total force_{peak}	Correlation	-.482	.879**	.143	-.287	-.265	1	.536*	.280
	Sig. (1-tailed)	.066	.000	.321	.171	.191		.030	.177
	N	11	13	13	13	13	13	13	13
Oestrogen	Correlation	-.071	.426*	-.174	-.168	-.142	.536*	1	.560**
	Sig. (1-tailed)	.370	.015	.285	.291	.322	.030		.001
	N	24	26	13	13	13	13	30	28
Progesterone	Correlation	-.112	.106	-.775**	-.033	-.033	.280	.560**	1.000
	Sig. (1-tailed)	.302	.304	.001	.457	.457	.177	.001	.
	N	24	26	13	13	13	13	28	28

SJ: squat jump. Grey lines: Nonparametric correlation. White lines: Parametric correlation. Bolt numbers: Statistic significance. *: Correlation is significant at the 0.05 level (1-tailed). **: Correlation is significant at the 0.01 level (1-tailed). Δ: (Post-Pre)/Pre. Sig: significance.

Appendix J – Chapter 4 parametricity

Shapiro-Wilk parametricity test chapter 4.

Variable	Jump	Phase	Time	Condition	P
Ankle angle	CMJ	Preparatory squat	Pre	Control	.716
				Training	.250
			Post	Control	.407
				Training	.158
Hip Angle	CMJ	Preparatory squat	Pre	Control	.048
				Training	.942
			Post	Control	.712
				Training	.652
Knee Angle	CMJ	Preparatory squat	Pre	Control	.482
				Training	.242
			Post	Control	.628
				Training	.534
Ankle angle	SJ	Preparatory squat	Pre	Control	.382
				Training	.504
			Post	Control	.076
				Training	.717
Hip Angle	SJ	Preparatory squat	Pre	Control	0.933
				Training	.273
			Post	Control	.102
				Training	.808
Knee Angle	SJ	Preparatory squat	Pre	Control	.719
				Training	.277
			Post	Control	.095
				Training	.817
Ankle angle	CMJ	Take-off	Pre	Control	.989
				Training	.393
			Post	Control	.009
				Training	.288
Hip Angle	CMJ	Take-off	Pre	Control	.784
				Training	.875
			Post	Control	.718
				Training	.815
Knee Angle	CMJ	Take-off	Pre	Control	.535
				Training	.336
			Post	Control	.733
				Training	.342
Ankle angle	SJ	Take-off	Pre	Control	.672
				Training	.582
			Post	Control	.488
				Training	.972
Hip Angle	SJ	Take-off	Pre	Control	.600
				Training	.513
			Post	Control	.788
				Training	.920
Knee Angle	SJ	Take-off	Pre	Control	.126
				Training	.393
			Post	Control	.382
				Training	.473
Ankle angle	CMJ	Landing	Pre	Control	.182
				Training	.136
			Post	Control	.617
				Training	.689

Hip Angle	CMJ	Landing	Pre	Control	.214
			Post	Training	.374
Knee Angle	CMJ	Landing	Pre	Control	.043
			Post	Training	.619
Ankle angle	SJ	Landing	Pre	Control	.992
			Post	Training	.990
Hip Angle	SJ	Landing	Pre	Control	.406
			Post	Training	.263
Knee Angle	SJ	Landing	Pre	Control	.399
			Post	Training	.661
Ankle angle	CMJ	Landing Squat	Pre	Control	.496
			Post	Training	.750
Hip Angle	CMJ	Landing Squat	Pre	Control	.442
			Post	Training	.350
Knee Angle	SJ	Landing	Pre	Control	.653
			Post	Training	.413
Ankle angle	CMJ	Landing Squat	Pre	Control	.306
			Post	Training	.504
Hip Angle	CMJ	Landing Squat	Pre	Control	.621
			Post	Training	.798
Knee Angle	CMJ	Landing Squat	Pre	Control	.750
			Post	Training	.363
Ankle angle	SJ	Landing Squat	Pre	Control	.655
			Post	Training	.120
Hip Angle	CMJ	Landing Squat	Pre	Control	.848
			Post	Training	.826
Knee Angle	CMJ	Landing Squat	Pre	Control	.060
			Post	Training	.518
Ankle angle	SJ	Landing Squat	Pre	Control	.123
			Post	Training	.407
Hip Angle	SJ	Landing Squat	Pre	Control	.150
			Post	Training	.281
Knee Angle	CMJ	Landing Squat	Pre	Control	.706
			Post	Training	.472
Ankle angular velocity	CMJ	Eccentric phase	Pre	Control	.002
			Post	Training	.676
Hip angular velocity	CMJ	Eccentric phase	Pre	Control	.746
			Post	Training	.829
Knee angular velocity	SJ	Landing Squat	Pre	Control	.110
			Post	Training	.448
Ankle angular velocity	SJ	Eccentric phase	Pre	Control	.678
			Post	Training	.445
Ankle angular velocity	CMJ	Eccentric phase	Pre	Control	.008
			Post	Training	.331
Hip angular velocity	CMJ	Eccentric phase	Pre	Control	.004
			Post	Training	.001
Knee angular velocity	CMJ	Eccentric phase	Pre	Control	.001
			Post	Training	.001
Ankle angular velocity	SJ	Eccentric phase	Pre	Control	.559
			Post	Training	.997
Ankle angular velocity	CMJ	Eccentric phase	Pre	Control	.004
			Post	Training	.002
Ankle angular velocity	CMJ	Eccentric phase	Pre	Control	.201
			Post	Training	.165
Ankle angular velocity	SJ	Eccentric phase	Pre	Control	.331
			Post	Training	.492
Ankle angular velocity	CMJ	Eccentric phase	Pre	Control	.403
			Post	Training	.088

			Post	Control	.786
				Training	.947
			Pre	Control	.173
Hip angular velocity	SJ	Eccentric phase		Training	.105
			Post	Control	.474
				Training	.035
			Pre	Control	.999
Knee angular velocity	SJ	Eccentric phase		Training	.525
			Post	Control	.001
				Training	.601
			Pre	Control	.071
Ankle angular velocity	CMJ	Concentric phase		Training	.081
			Post	Control	.437
				Training	.114
			Pre	Control	.450
Hip angular velocity	CMJ	Concentric phase		Training	.966
			Post	Control	.266
				Training	.611
			Pre	Control	.270
Knee angular velocity	CMJ	Concentric phase		Training	.063
			Post	Control	.126
				Training	.321
			Pre	Control	.133
Ankle angular velocity	SJ	Concentric phase		Training	.099
			Post	Control	.605
				Training	.707
			Pre	Control	.352
Hip angular velocity	SJ	Concentric phase		Training	.129
			Post	Control	.794
				Training	.991
			Pre	Control	.015
Knee angular velocity	SJ	Concentric phase		Training	.446
			Post	Control	.206
				Training	.708
			Pre	Control	.725
EMG_{RF}	CMJ	Rectus Femoris		Training	.811
			Post	Control	.212
				Training	.341
			Pre	Control	.339
EMG_{ST}	CMJ	Semitendinosus		Training	.423
			Post	Control	.958
				Training	.092
			Pre	Control	.814
EMG_{RF}	SJ	Rectus Femoris		Training	.015
			Post	Control	.244
				Training	.064
			Pre	Control	.325
EMG_{ST}	SJ	Semitendinosus		Training	.525
			Post	Control	.149
				Training	.332

Variables in bold are non-normally distributed and variables in light are normally distributed.

Shapiro-Wilk parametricity test Δ of Pre- and Post-test per group variables Chapter 4.

Phase	Jump	Condition	Delta	P
Preparatory Squat	CMJ	Training	Δ Ankle	.468

			Δ Hip	.163
			Δ Knee	.335
		Control	Δ Ankle	.572
			Δ Hip	.024
			Δ Knee	.718
		Training	Δ Ankle	.478
			Δ Hip	.103
	SJ		Δ Knee	.727
		Control	Δ Ankle	.580
			Δ Hip	.556
			Δ Knee	.022
		Training	Δ Ankle	.015
			Δ Hip	.431
		Control	Δ Knee	.025
	CMJ		Δ Ankle	.013
			Δ Hip	.251
			Δ Knee	.017
Take-off		Training	Δ Ankle	.051
			Δ Hip	.052
		Control	Δ Knee	.539
	SJ		Δ Ankle	.621
		Control	Δ Hip	.189
			Δ Knee	.004
		Training	Δ Ankle	.412
			Δ Hip	.845
		Control	Δ Knee	.320
	CMJ		Δ Ankle	.004
			Δ Hip	.592
			Δ Knee	.001
Landing		Training	Δ Ankle	.013
			Δ Hip	.840
		Control	Δ Knee	.450
	SJ		Δ Ankle	.001
		Control	Δ Hip	.071
			Δ Knee	.518
		Training	Δ Ankle	.193
			Δ Hip	.337
		Control	Δ Knee	.002
	CMJ		Δ Ankle	.840
			Δ Hip	.552
			Δ Knee	.780
Landing Squat		Training	Δ Ankle	.673
			Δ Hip	.429
		Control	Δ Knee	.351
	SJ		Δ Ankle	.001
		Control	Δ Hip	.066
			Δ Knee	.006
		Training	Δ Ankle	.001
			Δ Hip	.100
		Control	Δ Knee	.100
	Eccentric		Δ Ankle	.004
		Control	Δ Hip	.001
			Δ Knee	.048
Angular Velocity CMJ		Training	Δ Ankle	.015
	Concentric		Δ Hip	.003
			Δ Knee	.001

		Control	Δ Ankle	.001
			Δ Hip	.010
			Δ Knee	.009
		Training	Δ Ankle	.001
			Δ Hip	.001
	Eccentric		Δ Knee	.105
		Control	Δ Ankle	.001
			Δ Hip	.001
			Δ Knee	.010
Angular Velocity		Training	Δ Ankle	.001
SJ			Δ Hip	.001
			Δ Knee	.001
	Concentric		Δ Ankle	.001
		Control	Δ Hip	.001
			Δ Knee	.001
		Training	Δ EMG _{RF}	.402
			Δ EMG _{ST}	.185
	CMJ	Control	Δ EMG _{RF}	.456
			Δ EMG _{ST}	.395
EMG		Training	Δ EMG _{RF}	.004
			Δ EMG _{ST}	.506
	SJ	Control	Δ EMG _{RF}	.133
			Δ EMG _{ST}	.533

Variables in bold are non-normally distributed and variables in light are normally distributed.

Shapiro-Wilk parametricity test Δ of the dependent variables for hormone analysis Chapter 4.

Phase	Jump	Variable	P
Preparatory Squat	CMJ	Δ Ankle Angle	.222
		Δ Hip Angle	.032
		Δ knee Angle	.266
	SJ	Δ Ankle Angle	.386
		Δ Hip Angle	.197
		Δ knee Angle	.066
Take-off	CMJ	Δ Ankle Angle	.001
		Δ Hip Angle	.612
		Δ knee Angle	.001
	SJ	Δ Ankle Angle	.001
		Δ Hip Angle	.011
		Δ knee Angle	.001
Landing	CMJ	Δ Ankle Angle	.001
		Δ Hip Angle	.032
		Δ knee Angle	.001
	SJ	Δ Ankle Angle	.001
		Δ Hip Angle	.140
		Δ knee Angle	.108
Landing Squat	CMJ	Δ Ankle Angle	.001
		Δ Hip Angle	.001
		Δ knee Angle	.001
	SJ	Δ Ankle Angle	.001

		Δ Hip Angle	.001
		Δ knee Angle	.001
Eccentric	CMJ	Δ Ankle Angular velocity	.001
		Δ Hip Angular velocity	.001
Δ Knee Angular velocity		.990	
Concentric		Δ Ankle Angular velocity	.001
		Δ Hip Angular velocity	.259
Δ Knee Angular velocity		.015	
Eccentric	SJ	Δ Ankle Angular velocity	.367
		Δ Hip Angular velocity	.001
Δ Knee Angular velocity		.074	
Concentric		Δ Ankle Angular velocity	.331
		Δ Hip Angular velocity	.001
Δ Knee Angular velocity		.001	
EMG	CMJ	Δ EMG _{RF}	.002
		Δ EMG _{ST}	.001
	SJ	Δ EMG _{RF}	.198
		Δ EMG _{ST}	.406
		Oestrogen	.079
		Progesterone	.007

Variables in bold are non-normally distributed and variables in light are normally distributed.

Appendix K – Chapter 4 correlations

Correlations CMJ Ankle, Hip and Knee angles – Hormonal concentration																
		Preparatory Squat			Take-off			Landing			Landing Squat			Oestr	Progeste	
		Δ Ankle	Δ Hip	Δ Knee	Δ Ankle	Δ Hip	Δ Knee	Δ Ankle	Δ Hip	Δ Knee	Δ Ankle	Δ Hip	Δ Knee	rogen	rone	
Preparatory Squat	Δ Ankle	Correlation	1	-.218	.179	.084	.295	-.229	-.331*	.268	-.062	.173	.517**	.399*	-.052	-.279
		Sig. (1-tailed)	-	.128	.176	.341	.072	.130	.046	.088	.379	.194	.003	.020	.403	.098
		N	29	29	29	26	26	26	27	27	27	27	27	27	25	23
	Δ Hip	Correlation	-.218	1.000	.446**	.054	.074	.124	.039	-.048	.274	-.219	-.151	-.184	.201	.089
		Sig. (1-tailed)	.128	-	.008	.396	.361	.273	.423	.406	.084	.136	.225	.179	.168	.343
		N	29	29	29	26	26	26	27	27	27	27	27	27	25	23
	Δ Knee	Correlation	.179	.446**	1	-.043	.193	-.104	.043	.002	.212	-.118	.043	-.045	.058	.164
		Sig. (1-tailed)	.176	.008	-	.417	.172	.307	.415	.496	.144	.279	.416	.413	.391	.227
		N	29	29	29	26	26	26	27	27	27	27	27	27	25	23
Take-off	Δ Ankle	Correlation	.084	.054	-.043	1.000	-.007	-.169	-.359*	-.084	-.103	-.532**	-.243	-.556**	.168	-.001
		Sig. (1-tailed)	.341	.396	.417	-	.486	.186	.033	.339	.305	.002	.111	.001	.197	.498
		N	26	26	26	30	30	30	27	27	27	27	27	27	28	26
	Δ Hip	Correlation	.295	.074	.193	-.007	1	.129	.017	.464**	.536**	.052	.507**	.464**	-.088	-.245
		Sig. (1-tailed)	.072	.361	.172	.486	-	.248	.466	.007	.002	.399	.003	.007	.328	.114
		N	26	26	26	30	30	30	27	27	27	27	27	27	28	26
	Δ Knee	Correlation	-.229	.124	-.104	-.169	.129	1.000	.081	-.303	.146	.363*	-.187	.126	.139	.044
		Sig. (1-tailed)	.130	.273	.307	.186	.248	-	.345	.062	.234	.031	.175	.265	.240	.416
		N	26	26	26	30	30	30	27	27	27	27	27	27	28	26
Landing	Δ Ankle	Correlation	-.331*	.039	.043	-.359*	.017	.081	1.000	-.238	.077	.015	-.063	-.071	-.138	.191

		Sig. (1-tailed)	.046	.423	.415	.033	.466	.345	-	.103	.343	.469	.371	.354	.246	.180		
		N	27	27	27	27	27	27	30	30	30	30	30	30	30	27	25	
	Δ Hip	Correlation	.268	-.048	.002	-.084	.464**	-.303	-.238	1.000	.453**	-.092	.707**	.383*	-.075	-.244		
		Sig. (1-tailed)	.088	.406	.496	.339	.007	.062	.103	-	.006	.314	.000	.018	.356	.120		
		N	27	27	27	27	27	27	30	30	30	30	30	30	27	25		
	Δ Knee	Correlation	-.062	.274	.212	-.103	.536**	.146	.077	.453**	1.000	.014	.318*	.200	-.034	-.300		
		Sig. (1-tailed)	.379	.084	.144	.305	.002	.234	.343	.006	-	.471	.043	.145	.433	.072		
		N	27	27	27	27	27	27	30	30	30	30	30	30	27	25		
	Landing Squat	Δ Ankle	Correlation	.173	-.219	-.118	-.532**	.052	.363*	.015	-.092	.014	1.000	.159	.653**	.235	.060	
			Sig. (1-tailed)	.194	.136	.279	.002	.399	.031	.469	.314	.471	-	.201	.001	.119	.388	
			N	27	27	27	27	27	27	30	30	30	30	30	30	27	25	
		Δ Hip	Correlation	.517**	-.151	.043	-.243	.507**	-.187	-.063	.707**	.318*	.159	1.000	.708**	-.075	-.176	
Sig. (1-tailed)			.003	.225	.416	.111	.003	.175	.371	.001	.043	.201	-	.001	.355	.200		
N			27	27	27	27	27	27	30	30	30	30	30	30	27	25		
Δ Knee		Correlation	.399*	-.184	-.045	-.556**	.464**	.126	-.071	.383*	.200	.653**	.708**	1.000	.142	.018		
		Sig. (1-tailed)	.020	.179	.413	.001	.007	.265	.354	.018	.145	.001	.001	-	.241	.466		
		N	27	27	27	27	27	27	30	30	30	30	30	30	27	25		
Oestrogen		Oestrogen	Correlation	-.052	.201	.058	.168	-.088	.139	-.138	-.075	-.034	.235	-.075	.142	1	.392*	
			Sig. (1-tailed)	.403	.168	.391	.197	.328	.240	.246	.356	.433	.119	.355	.241	-	.020	
			N	25	25	25	28	28	28	27	27	27	27	27	27	30	28	
Progesterone	Progesterone	Correlation	-.279	.089	.164	-.001	-.245	.044	.191	-.244	-.300	.060	-.176	.018	.392*	1		
		Sig. (1-tailed)	.098	.343	.227	.498	.114	.416	.180	.120	.072	.388	.200	.466	.020			
		N	23	23	23	26	26	26	25	25	25	25	25	25	28	28		

Grey cells: Nonparametric correlation. White lines: Parametric correlation. Bolt numbers: Statistic significance. *: Correlation is significant at the 0.05 level (1-tailed). **: Correlation is significant at the 0.01 level (1-tailed). Sig: significance. N: sample size.

Correlations CMJ Ankle, Hip and Knee angular velocity and EMG – Hormonal Concentration

			Eccentric			Concentric			EMG		Hormones	
			Δ Ankle Angular velocity	Δ Hip Angular velocity	Δ Knee Angular velocity	Δ Ankle Angular velocity	Δ Hip Angular velocity	Δ Knee Angular velocity	Δ EMG _{RF}	Δ EMG _{ST}	Oestrogen	Progesterone
Eccentric	Δ Ankle Angular velocity	Correlation	1.000	.065	.307	.155	.114	.127	.310	-.357	.180	.107
		Sig. (1-tailed)	.	.381	.072	.252	.311	.287	.228	.193	.206	.318
		N	24	24	24	21	21	22	8	8	23	22
	Δ Hip Angular velocity	Correlation	.065	1.000	.469**	.061	.135	.125	-.055	.200	.062	.080
		Sig. (1-tailed)	.381	.	.009	.389	.261	.271	.441	.290	.382	.356
		N	24	28	25	24	25	26	10	10	26	24
	Δ Knee Angular velocity	Correlation	.307	.469**	1	.074	.234	-.084	.643*	-.357	-.162	-.280
		Sig. (1-tailed)	.072	.009		.375	.147	.352	.043	.193	.225	.098
		N	24	25	25	21	22	23	8	8	24	23
Concentric	Δ Ankle Angular velocity	Correlation	.155	.061	.074	1.000	.204	.335	.164	.115	.045	-.279
		Sig. (1-tailed)	.252	.389	.375	.	.176	.055	.326	.376	.421	.110
		N	21	24	21	24	23	24	10	10	22	21
	Δ Hip Angular velocity	Correlation	.114	.135	.234	.204	1	.502**	.636*	.297	.393*	-.041
		Sig. (1-tailed)	.311	.261	.147	.176		.005	.024	.202	.032	.429
		N	21	25	22	23	25	25	10	10	23	22
	Δ Knee Angular velocity	Correlation	.127	.125	-.084	.335	.502**	1.000	.455	-.285	.302	.082
		Sig. (1-tailed)	.287	.271	.352	.055	.005	.	.093	.213	.076	.355
		N	22	26	23	24	25	26	10	10	24	23
EMG	Δ EMG _{RF}	Correlation	.310	-.055	.643*	.164	.636*	.455	1.000	.196	.475	.009
		Sig. (1-tailed)	.228	.441	.043	.326	.024	.093	.	.271	.060	.489

		N	8	10	8	10	10	10	12	12	12	11
	Δ EMG _{ST}	Correlation	-.357	.200	-.357	.115	.297	-.285	.196	1.000	.274	.650*
		Sig. (1-tailed)	.193	.290	.193	.376	.202	.213	.271	.	.194	.015
		N	8	10	8	10	10	10	12	12	12	11
Hormones	Oestrogen	Correlation	.180	.062	-.162	.045	.393*	.302	.475	.274	1	.560**
		Sig. (1-tailed)	.206	.382	.225	.421	.032	.076	.060	.194		.001
		N	23	26	24	22	23	24	12	12	30	28
	Progesterone	Correlation	.107	.080	-.280	-.279	-.041	.082	.009	.650*	.560**	1.000
		Sig. (1-tailed)	.318	.356	.098	.110	.429	.355	.489	.015	.001	.
		N	22	24	23	21	22	23	11	11	28	28

Grey cells: Nonparametric correlation. White cells: Parametric correlation. Bolt numbers: Statistic significance. *: Correlation is significant at the 0.05 level (1-tailed). **: Correlation is significant at the 0.01 level (1-tailed). Sig: significance. N: sample size.

Correlations SJ Ankle, Hip and Knee angles – Hormonal concentration

		Preparatory Squat			Take-off			Landing			Landing Squat			Oestrogen	Progesterone	
		Δ Ankle	Δ Hip	Δ Knee	Δ Ankle	Δ Hip	Δ Knee	Δ Ankle	Δ Hip	Δ Knee	Δ Ankle	Δ Hip	Δ Knee			
Preparatory Squat	Δ Ankle	Correlation	1.000	-.211	.685**	.234	-.058	-.021	-.218	-.122	.212	.470**	.400*	.458**	-.062	-.121
		Sig. (1-tailed)	-	.123	.001	.107	.380	.456	.128	.264	.135	.005	.016	.006	.376	.277
		N	32	32	32	30	30	30	29	29	29	29	29	29	28	26
	Δ Hip	Correlation	-.211	1.000	.205	.212	.044	.186	-.038	-.046	.111	-.145	-.232	-.089	-.279	-.073
		Sig. (1-tailed)	.123	-	.130	.131	.408	.163	.423	.406	.284	.227	.113	.323	.075	.361
		N	32	32	32	30	30	30	29	29	29	29	29	29	28	26
	Δ Knee	Correlation	.685**	.205	1.000	.306*	-.117	.185	-.351*	-.108	.361*	.145	.050	.098	-.124	-.127
		Sig. (1-tailed)	.001	.130	-	.050	.269	.163	.031	.289	.027	.227	.398	.306	.265	.268
		N	32	32	32	30	30	30	29	29	29	29	29	29	28	26
Take-off	Δ Ankle	Correlation	.234	.212	.306*	1.000	-.559**	.011	-.165	.094	.020	.278	-.071	.079	.347*	.256
		Sig. (1-tailed)	.107	.131	.050	-	.001	.477	.196	.314	.460	.072	.356	.341	.038	.108
		N	30	30	30	31	31	31	29	29	29	29	29	29	27	25
	Δ Hip	Correlation	-.058	.044	-.117	-.559**	1.000	-.062	-.183	-.061	.265	-.161	-.047	.091	-.161	-.042
		Sig. (1-tailed)	.380	.408	.269	.001	-	.369	.171	.377	.083	.203	.404	.320	.210	.421
		N	30	30	30	31	31	31	29	29	29	29	29	29	27	25
	Δ Knee	Correlation	-.021	.186	.185	.011	-.062	1.000	-.045	-.312*	-.165	.098	-.292	-.147	.061	.205
		Sig. (1-tailed)	.456	.163	.163	.477	.369	-	.408	.050	.197	.306	.062	.224	.382	.163
		N	30	30	30	31	31	31	29	29	29	29	29	29	27	25
Landing	Δ Ankle	Correlation	-.218	-.038	-.351*	-.165	-.183	-.045	1.000	-.067	-.234	-.265	-.230	-.437**	-.071	.126
		Sig. (1-tailed)	.128	.423	.031	.196	.171	.408	-	.359	.103	.075	.107	.007	.363	.274
		N	29	29	29	29	29	29	31	31	31	31	31	31	27	25
	Δ Hip	Correlation	-.122	-.046	-.108	.094	-.061	-.312*	-.067	1	.040	-.308*	.042	-.255	-.011	-.013

		Sig. (1-tailed)	.264	.406	.289	.314	.377	.050	.359	-	.415	.046	.412	.083	.478	.475	
		N	29	29	29	29	29	29	29	31	31	31	31	31	31	27	25
	Δ Knee	Correlation	.212	.111	.361*	.020	.265	-.165	-.234	.040	1.000	.133	.024	.367*	-.051	-.124	
		Sig. (1-tailed)	.135	.284	.027	.460	.083	.197	.103	.415	-	.238	.449	.021	.400	.278	
		N	29	29	29	29	29	29	31	31	31	31	31	31	31	27	25
Landing Squat	Δ Ankle	Correlation	.470**	-.145	.145	.278	-.161	.098	-.265	-.308*	.133	1.000	.096	.550**	.410*	.051	
		Sig. (1-tailed)	.005	.227	.227	.072	.203	.306	.075	.046	.238	-	.305	.001	.017	.405	
		N	29	29	29	29	29	29	31	31	31	31	31	31	31	27	25
	Δ Hip	Correlation	.400*	-.232	.050	-.071	-.047	-.292	-.230	.042	.024	.096	1.000	.578**	-.058	-.291	
		Sig. (1-tailed)	.016	.113	.398	.356	.404	.062	.107	.412	.449	.305	-	.001	.387	.079	
		N	29	29	29	29	29	29	31	31	31	31	31	31	31	27	25
	Δ Knee	Correlation	.458**	-.089	.098	.079	.091	-.147	-.437**	-.255	.367*	.550**	.578**	1.000	.193	-.025	
		Sig. (1-tailed)	.006	.323	.306	.341	.320	.224	.007	.083	.021	.001	.001	-	.167	.453	
		N	29	29	29	29	29	29	31	31	31	31	31	31	31	27	25
	Oestrogen	Oestrogen	Correlation	-.062	-.279	-.124	.347*	-.161	.061	-.071	-.011	-.051	.410*	-.058	.193	1.000	.392*
			Sig. (1-tailed)	.376	.075	.265	.038	.210	.382	.363	.478	.400	.017	.387	.167	-	.020
			N	28	28	28	27	27	27	27	27	27	27	27	27	27	30
Progesterone	Progesterone	Correlation	-.121	-.073	-.127	.256	-.042	.205	.126	-.013	-.124	.051	-.291	-.025	.392*	1.000	
		Sig. (1-tailed)	.277	.361	.268	.108	.421	.163	.274	.475	.278	.405	.079	.453	.020	-	
		N	26	26	26	25	25	25	25	25	25	25	25	25	25	28	28

Grey Cells: Nonparametric correlation. White Cells: Parametric correlation. Bolt numbers: Statistic significance. *: Correlation is significant at the 0.05 level (1-tailed). **: Correlation is significant at the 0.01 level (1-tailed). N: sample size.

Correlations SJ Ankle, Hip and Knee angular velocity and EMG – Hormonal Concentration

		Eccentric			Concentric			EMG		Hormones		
		Δ Ankle Angular velocity	Δ Hip Angular velocity	Δ Knee Angular velocity	Δ Ankle Angular velocity	Δ Hip Angular velocity	Δ Knee Angular velocity	Δ EMG _{RF}	Δ EMG _{ST}	Oestrogen	Progesterone	
Eccentric	Δ Ankle Angular velocity	Correlation	1	.332	.530**	.155	.469	.691**	1.000**	1.000	-.446*	-.106
		Sig. (1-tailed)		.083	.010	.306	.062	.009	.	.	.032	.343
		N	20	19	19	13	12	11	3	2	18	17
	Δ Hip Angular velocity	Correlation	.332	1.000	.546**	.042	.368	-.112	.400	.500	.028	.106
		Sig. (1-tailed)	.083	.	.008	.444	.108	.365	.300	.333	.456	.348
		N	19	21	19	14	13	12	4	3	18	16
	Δ Knee Angular velocity	Correlation	.530**	.546**	1	-.140	.175	.218	.800	1.000**	.212	.444*
		Sig. (1-tailed)	.010	.008		.324	.293	.260	.100	.	.192	.032
		N	19	19	21	13	12	11	4	3	19	18
Concentric	Δ Ankle Angular velocity	Correlation	.155	.042	-.140	1	.211	.008	-.300	.200	-.243	.007
		Sig. (1-tailed)	.306	.444	.324		.234	.489	.312	.400	.202	.491
		N	13	14	13	16	14	13	5	4	14	13
	Δ Hip Angular velocity	Correlation	.469	.368	.175	.211	1.000	.783**	-.100	-.800	.058	-.477
		Sig. (1-tailed)	.062	.108	.293	.234	.	.001	.436	.100	.426	.058
		N	12	13	12	14	15	12	5	4	13	12
	Δ Knee Angular velocity	Correlation	.691**	-.112	.218	.008	.783**	1.000	.200	-1.000**	-.370	-.256
		Sig. (1-tailed)	.009	.365	.260	.489	.001	.	.400	.	.131	.238
		N	11	12	11	13	12	13	4	3	11	10
EMG	Δ EMG _{RF}	Correlation	1.000**	.400	.800	-.300	-.100	.200	1.000	.262	.619*	.551
		Sig. (1-tailed)	.	.300	.100	.312	.436	.400	.	.265	.038	.079

		N	3	4	4	5	5	4	9	8	9	8
	Δ EMG_{ST}	Correlation	1.000**	.500	1.000**	.200	-.800	-1.000**	.262	1.000	.719*	.378
		Sig. (1-tailed)	.	.333	.	.400	.100	.	.265	.	.022	.201
		N	2	3	3	4	4	3	8	8	8	7
Hormones	Oestrogen	Correlation	-.446*	.028	.212	-.243	.058	-.370	.619*	.719*	1.000	.560**
		Sig. (1-tailed)	.032	.456	.192	.202	.426	.131	.038	.022	.	.001
		N	18	18	19	14	13	11	9	8	30	28
	Progesterone	Correlation	-.106	.106	.444*	.007	-.477	-.256	.551	.378	.560**	1.000
		Sig. (1-tailed)	.343	.348	.032	.491	.058	.238	.079	.201	.001	.
		N	17	16	18	13	12	10	8	7	28	28

Grey cells: Nonparametric correlation. White cells: Parametric correlation. Bolt numbers: Statistic significance. *: Correlation is significant at the 0.05 level (1-tailed). **: Correlation is significant at the 0.01 level (1-tailed). Sig: significance. N: sample size.

Appendix L – Chapter 5 parametricity

Shapiro-Wilk parametricity test chapter 5. Variables in bold are non-normally distributed and variables in light are normally distributed.

Variable	Group	Ovulatory	Follicular	Luteal
ROM _{Max}	Non-Dominant	0.437	0.963	0.277
	Dominant	0.686	0.621	0.051
Torque _{Max}	Non-Dominant	0.844	0.747	0.692
	Dominant	0.385	0.210	0.645
FSS _{ROM}	Non-Dominant	0.681	0.563	0.964
	Dominant	0.338	0.478	0.095
FSS _{torque}	Non-Dominant	0.508	0.007	0.433
	Dominant	0.039	0.001	0.028
S _{MTU}	Non-Dominant	0.316	0.621	0.561
	Dominant	0.418	0.018	0.080
Energy	Non-Dominant	0.256	0.019	0.162
	Dominant	0.245	0.007	0.161
Calf Circumference	Non-Dominant	0.002	0.148	0.074
	Dominant	0.002	0.334	0.042
Thigh Circumference	Non-Dominant	0.033	0.148	0.003
	Dominant	0.041	0.164	0.013
Hips Circumference	-	0.101	0.235	0.118
Waist Circumference	-	0.001	0.001	0.001
Body mass	-	0.001	0.001	0.001
Height	-	0.001	0.420	0.001
Body Fat	-	0.694	0.618	0.642
Body Lean	-	0.694	0.618	0.642
Water	-	0.576	0.905	0.967
Basal Metabolism	-	0.009	0.026	0.008
BMI	-	0.001	0.001	0.001
Total PASS	-	0.315	0.673	0.093
Mode PASS	-	0.026	0.005	0.026
PASS Cog Anx	-	0.044	0.699	0.251
PASS Esc	-	0.134	0.218	0.431
PASS Fear	-	0.195	0.025	0.222
PASS Physio	-	0.319	0.289	0.150
IWT	-	0.005	0.005	0.008
Cholesterol	-	0.446	0.098	0.521
Triglycerides	-	0.432	0.237	0.607
Glucose	-			
Lactate	-	0.001	0.085	0.780
Length	Non-Dominant	0.195	0.020	0.370
	Dominant	0.011	0.020	0.274
Width	Non-Dominant	0.299	0.533	0.487
	Dominant	0.739	0.355	0.786
CSA	Non-Dominant	0.019	0.001	0.571
	Dominant	0.817	0.627	0.323
Fat thickness	Non-Dominant	0.547	0.250	0.339
	Dominant	0.163	0.139	0.288
ST thickness	Non-Dominant	0.430	0.039	0.682
	Dominant	0.491	0.580	0.660
Total Lean thickness	Non-Dominant	0.499	0.794	0.165
	Dominant	0.957	0.121	0.584
Force _{peak} CMJ	Non-Dominant	0.001	0.001	0.001
	Dominant	0.001	0.001	0.001

Impulse CMJ	Non-Dominant	0.365	0.865	0.862
	Dominant	0.085	0.714	0.411
Peak force CMJ	Non-Dominant	0.410	0.985	0.216
	Dominant	0.236	0.051	0.834
V _{take-off} CMJ	-	0.729	0.592	0.390
Jump height CMJ	-	0.454	0.376	0.156
Total impulse CMJ	-	0.187	0.014	0.059
Total Force _{peak} CMJ	-	0.130	0.125	0.993
Impulse SJ	Non-Dominant	0.340	0.632	0.469
	Dominant	0.700	0.605	0.277
Force _{peak} SJ	Non-Dominant	0.417	0.096	0.541
	Dominant	0.047	0.028	0.711
V _{take-off} SJ	-	0.832	0.990	0.990
Jump height SJ	-	0.492	0.937	0.689
Total impulse SJ	-	0.039	0.442	0.099
Total Force _{peak} SJ	-	0.059	0.014	0.474
EMG _{RF} CMJ	Non-Dominant	0.135	0.382	0.351
	Dominant	0.248	0.243	0.072
EMG _{ST} CMJ	Non-dancers	0.040	0.302	0.903
	Dancers	0.282	0.859	0.820
EMG _{RF} SJ	Non-dancers	0.581	0.486	0.598
	Dancers	0.375	0.409	0.927
EMG _{ST} SJ	Non-dancers	0.149	0.247	0.224
	Dancers	0.022	0.626	0.371
Oestrogen	-	0.331	0.511	0.049
Progesterone	-	0.033	0.068	0.014
Relaxin	-	0.018	0.001	0.002

Shapiro-Wilk parametricity test chapter $\Delta [(D-nd)/D]$ Chapter 5. Variables in bold are non-normally distributed and variables in light are normally distributed.

Variable	Follicular	Ovulatory	Luteal
ΔROM_{Max}	0.019	0.646	0.353
$\Delta Torque_{Max}$	0.204	0.028	0.118
ΔFSS_{ROM}	0.290	0.338	0.729
ΔFSS_{torque}	0.049	0.736	0.879
ΔS_{MTU}	0.091	0.154	0.390
$\Delta Energy$	0.012	0.174	0.390
$\Delta CMJ Impulse$	0.001	0.027	0.558
$\Delta CMJ force_{peak}$	0.029	0.184	0.662
$\Delta SJ Impulse$	0.001	0.001	0.001
$\Delta SJ force_{peak}$	0.635	0.086	0.433
$\Delta Length$	0.001	0.001	0.001
$\Delta Width$	0.810	0.238	0.134
ΔCSA	0.371	0.767	0.724
$\Delta Fat thickness$	0.217	0.224	0.969
$\Delta ST thickness$	0.864	0.310	0.024
$\Delta Total Lean thickness$	0.391	0.032	0.526
$\Delta EMG_{RF} CMJ$	0.455	0.765	0.803
$\Delta EMG_{ST} CMJ$	0.361	0.737	0.195
$\Delta EMG_{RF} SJ$	0.853	0.203	0.686
$\Delta EMG_{ST} SJ$	0.212	0.262	0.202
$\Delta Calf Circum$	0.435	0.074	0.424
$\Delta Thigh Circum$	0.392	0.018	0.506

Shapiro-Wilk parametricity test of hormonal ratios

	Luteal/Follicular	Ovulatory/Follicular
Oestrogen	.009	.027
Progesterone	.002	.017
Relaxin	.000	.252
Length	.000	.007
Width	.007	.085
CSA	.278	.109
Fat thickness	.121	.275
ST thickness	.007	.097
Total Lean thickness	.001	.058
Force _{peak} CMJ	.001	.001
Impulse CMJ	.895	.872
V _{take-off} CMJ	.412	.874
Jump height CMJ	.759	.697
Total impulse CMJ	.231	.000
Total Force _{peak} CMJ	.539	.571
Force _{peak} SJ	.003	.000
Impulse SJ	.745	.986
V _{take-off} SJ	.346	.117
Jump height SJ	.662	.062
Total impulse SJ	.778	.195
Total Force _{peak} SJ	.139	.816
EMG _{RF} CMJ	.048	.484
EMG _{ST} CMJ	.147	.000
EMG _{RF} SJ	.029	.009
EMG _{ST} SJ	.033	.324
ROM _{Max}	.175	.057
Torque _{Max}	.124	.209
FSS _{ROM}	.017	.151
FSS _{torque}	.016	.003
SMTU	.086	.040
Energy	.201	.176

Appendix M – Chapter 5 correlations

Correlation muscle structure – Hormonal concentration (Luteal/Follicular)										
		Muscle length	Muscle width	Muscle CSA	Fat thickness	St thickness	Lean	Oestrogen	Progesterone	Relaxin
Muscle length	Correlation	1.000	.299	.334	.344	.060	.144	-.560**	.587*	-.029
	Sig. (1-tailed)	.	.122	.088	.081	.406	.284	.008	.022	.464
	N	18	17	18	18	18	18	18	12	12
Muscle width	Correlation	.299	1.000	.712**	.333	.343	.765**	-.040	-.180	.199
	Sig. (1-tailed)	.122	.	.001	.096	.089	.000	.439	.288	.268
	N	17	17	17	17	17	17	17	12	12
Muscle CSA	Correlation	.334	.712**	1.000	.195	.243	.498*	-.413*	.258	-.198
	Sig. (1-tailed)	.088	.001	.	.219	.166	.018	.044	.209	.269
	N	18	17	18	18	18	18	18	12	12
Fat thickness	Correlation	.344	.333	.195	1.000	.564**	.606**	-.480*	.513*	.683**
	Sig. (1-tailed)	.081	.096	.219	.	.007	.004	.022	.044	.007
	N	18	17	18	18	18	18	18	12	12
ST thickness	Correlation	.060	.343	.243	.564**	1.000	.633**	-.251	.274	.498*
	Sig. (1-tailed)	.406	.089	.166	.007	.	.002	.158	.194	.050
	N	18	17	18	18	18	18	18	12	12
Lean	Correlation	.144	.765**	.498*	.606**	.633**	1.000	-.234	-.007	.626*
	Sig. (1-tailed)	.284	.000	.018	.004	.002	.	.175	.491	.015
	N	18	17	18	18	18	18	18	12	12
Oestrogen	Correlation	-.560**	-.040	-.413*	-.480*	-.251	-.234	1.000	-.378	.143
	Sig. (1-tailed)	.008	.439	.044	.022	.158	.175	.	.091	.329
	N	18	17	18	18	18	18	22	14	12
Progesterone	Correlation	.587*	-.180	.258	.513*	.274	-.007	-.378	1.000	.029
	Sig. (1-tailed)	.022	.288	.209	.044	.194	.491	.091	.	.464
	N	12	12	12	12	12	12	14	14	12
Relaxin	Correlation	-.029	.199	-.198	.683**	.498*	.626*	.143	.029	1.000
	Sig. (1-tailed)	.464	.268	.269	.007	.050	.015	.329	.464	.

N 12 12 12 12 12 12 12 12 12

Grey cells: Nonparametric correlation. White cells: Parametric correlation. Bolt numbers: Statistic significance. *: Correlation is significant at the 0.05 level (1-tailed). **: Correlation is significant at the 0.01 level (1-tailed). CSA: Cross-sectional area. ST: semitendinosus. Sig: significance. N: sample size.

Correlation Flexibility – Hormonal concentration Luteal/Follicular

		ROM _{Max}	Torque _{Max}	FSS _{ROM}	FSS _{torque}	S _{MTU}	Energy	Oestrogen	Progesterone	Relaxin
ROM _{Max}	Correlation	1	.334	.329	-.103	-.007	.199	-.041	.943**	-.127
	Sig. (1-tailed)		.065	.067	.324	.488	.187	.429	.000	.347
	N	22	22	22	22	22	22	22	14	12
Torque _{Max}	Correlation	.334	1	-.094	.225	.527**	.582**	-.068	.653**	-.014
	Sig. (1-tailed)	.065		.338	.157	.006	.002	.382	.006	.483
	N	22	22	22	22	22	22	22	14	12
FSS _{ROM}	Correlation	.329	-.094	1.000	.453*	-.217	-.151	.118	.031	.014
	Sig. (1-tailed)	.067	.338	.	.017	.166	.252	.301	.458	.483
	N	22	22	22	22	22	22	22	14	12
FSS _{torque}	Correlation	-.103	.225	.453*	1.000	-.023	.029	.242	.121	-.339
	Sig. (1-tailed)	.324	.157	.017	.	.459	.449	.139	.341	.140
	N	22	22	22	22	22	22	22	14	12
S _{MTU}	Correlation	-.007	.527**	-.217	-.023	1	.875**	.052	.487*	.226
	Sig. (1-tailed)	.488	.006	.166	.459		.000	.409	.039	.240
	N	22	22	22	22	22	22	22	14	12
Energy	Correlation	.199	.582**	-.151	.029	.875**	1	.027	.487*	-.014
	Sig. (1-tailed)	.187	.002	.252	.449	.000		.452	.039	.483
	N	22	22	22	22	22	22	22	14	12
Oestrogen	Correlation	-.041	-.068	.118	.242	.052	.027	1.000	-.378	.143
	Sig. (1-tailed)	.429	.382	.301	.139	.409	.452	.	.091	.329
	N	22	22	22	22	22	22	22	14	12
Progesterone	Correlation	.943**	.653**	.031	.121	.487*	.487*	-.378	1.000	.029
	Sig. (1-tailed)	.000	.006	.458	.341	.039	.039	.091	.	.464
	N	14	14	14	14	14	14	14	14	12

Relaxin	Correlation	-.127	-.014	.014	-.339	.226	-.014	.143	.029	1.000
	Sig. (1-tailed)	.347	.483	.483	.140	.240	.483	.329	.464	.
	N	12	12	12	12	12	12	12	12	12

Grey lines: Nonparametric Pearson. White lines: Parametric Pearson. Bolt numbers: Statistic significance. *: Pearson is significant at the 0.05 level (1-tailed). **: Pearson is significant at the 0.01 level (1-tailed). D: Dominant limb. nD: non-dominant limb. Cir: circumference. Sig: significance. N: sample size.

		Impulse	Force _{Peak}	Take-off velocity	Jump height	Total Impulse	Total Force _{peak}	Oestrogen	Progesterone	Relaxin
Impulse	Correlation	1	.618**	-.096	-.051	-.197	.353	-.023	.013	-.014
	Sig. (1-tailed)		.001	.390	.441	.281	.144	.460	.482	.483
	N	22	22	11	11	11	11	22	14	12
Force _{Peak}	Correlation	.618**	1.000	-.629*	-.583*	-.727**	.891**	-.041	.389	.141
	Sig. (1-tailed)	.001	.	.019	.030	.006	.000	.429	.085	.331
	N	22	22	11	11	11	11	22	14	12
Take-off velocity	Correlation	-.096	-.629*	1	.991**	.958**	-.741**	-.319	.072	.143
	Sig. (1-tailed)	.390	.019		.000	.000	.005	.170	.439	.394
	N	11	11	11	11	11	11	11	7	6
Jump height	Correlation	-.051	-.583*	.991**	1	.944**	-.678*	-.346	.072	.143
	Sig. (1-tailed)	.441	.030	.000		.000	.011	.148	.439	.394
	N	11	11	11	11	11	11	11	7	6
Total Impulse	Correlation	-.197	-.727**	.958**	.944**	1	-.771**	-.309	.072	.600
	Sig. (1-tailed)	.281	.006	.000	.000		.003	.178	.439	.104
	N	11	11	11	11	11	11	11	7	6
Total Force _{peak}	Correlation	.353	.891**	-.741**	-.678*	-.771**	1	.091	.414	-.371
	Sig. (1-tailed)	.144	.000	.005	.011	.003		.395	.178	.234
	N	11	11	11	11	11	11	11	7	6
Oestrogen	Correlation	-.023	-.041	-.319	-.346	-.309	.091	1.000	-.378	.143
	Sig. (1-tailed)	.460	.429	.170	.148	.178	.395	.	.091	.329
	N	22	22	11	11	11	11	22	14	12
Progesterone	Correlation	.013	.389	.072	.072	.072	.414	-.378	1.000	.029
	Sig. (1-tailed)	.482	.085	.439	.439	.439	.178	.091	.	.464

	N	14	14	7	7	7	7	14	14	12
Relaxin	Correlation	-.014	.141	.143	.143	.600	-.371	.143	.029	1.000
	Sig. (1-tailed)	.483	.331	.394	.394	.104	.234	.329	.464	.
	N	12	12	6	6	6	6	12	12	12

Grey lines: Nonparametric Pearson. White lines: Parametric Pearson. Bolt numbers: Statistic significance. *: Pearson is significant at the 0.05 level (1-tailed). **: Pearson is significant at the 0.01 level (1-tailed). D: Dominant limb. nD: non-dominant limb. Cir: circumference. Sig: significance. N: sample size.

		Impulse	Force _{Peak}	Take-off velocity	Jump height	Total Impulse	Total Force _{Peak}	Oestrogen	Progesterone	Relaxin
Impulse	Correlation	1	.030	-.322	-.314	-.224	-.194	-.057	-.063	-.042
	Sig. (1-tailed)		.447	.167	.173	.254	.284	.401	.416	.448
	N	22	22	11	11	11	11	22	14	12
Force_{Peak}	Correlation	.030	1.000	-.164	-.036	.000	.955**	-.045	.282	.269
	Sig. (1-tailed)	.447	.	.315	.458	.500	.000	.421	.165	.199
	N	22	22	11	11	11	11	22	14	12
Take-off velocity	Correlation	-.322	-.164	1	.986**	.957**	-.170	-.391	.595	-.486
	Sig. (1-tailed)	.167	.315		.000	.000	.308	.117	.080	.164
	N	11	11	11	11	11	11	11	7	6
Jump height	Correlation	-.314	-.036	.986**	1	.939**	-.161	-.373	.450	-.486
	Sig. (1-tailed)	.173	.458	.000		.000	.318	.129	.155	.164
	N	11	11	11	11	11	11	11	7	6
Total Impulse	Correlation	-.224	.000	.957**	.939**	1	-.104	-.391	.414	-.371
	Sig. (1-tailed)	.254	.500	.000	.000		.380	.117	.178	.234
	N	11	11	11	11	11	11	11	7	6
Total Force_{Peak}	Correlation	-.194	.955**	-.170	-.161	-.104	1	-.027	.342	.143
	Sig. (1-tailed)	.284	.000	.308	.318	.380		.468	.226	.394
	N	11	11	11	11	11	11	11	7	6
Oestrogen	Correlation	-.057	-.045	-.391	-.373	-.391	-.027	1.000	-.378	.143
	Sig. (1-tailed)	.401	.421	.117	.129	.117	.468	.	.091	.329
	N	22	22	11	11	11	11	22	14	12
Progesterone	Correlation	-.063	.282	.595	.450	.414	.342	-.378	1.000	.029

	Sig. (1-tailed)	.416	.165	.080	.155	.178	.226	.091	.	.464
	N	14	14	7	7	7	7	14	14	12
Relaxin	Correlation	-.042	.269	-.486	-.486	-.371	.143	.143	.029	1.000
	Sig. (1-tailed)	.448	.199	.164	.164	.234	.394	.329	.464	.
	N	12	12	6	6	6	6	12	12	12

Grey lines: Nonparametric Pearson. White lines: Parametric Pearson. Bolt numbers: Statistic significance. *: Pearson is significant at the 0.05 level (1-tailed). **: Pearson is significant at the 0.01 level (1-tailed). D: Dominant limb. nD: non-dominant limb. Cir: circumference. Sig: significance. N: sample size.

		Correlation EMG – Hormonal concentration Luteal/Follicular						
		CMJ EMG _{RF}	CMJ EMG _{ST}	SJ EMG _{RF}	SJ EMG _{ST}	Oestrogen	Progesterone	Relaxin
CMJ EMG _{RF}	Correlation	1.000	.550*	-.427	-.390	-.611*	.587	.239
	Sig. (1-tailed)	.	.021	.109	.170	.010	.063	.303
	N	14	14	10	8	14	8	7
CMJ EMG _{ST}	Correlation	.550*	1.000	-.265	-.102	-.926**	.822**	-.426
	Sig. (1-tailed)	.021	.	.230	.405	.000	.006	.170
	N	14	14	10	8	14	8	7
SJ EMG _{RF}	Correlation	-.427	-.265	1.000	.703*	.183	.395	.790*
	Sig. (1-tailed)	.109	.230	.	.012	.284	.167	.017
	N	10	10	12	10	12	8	7
SJ EMG _{ST}	Correlation	-.390	-.102	.703*	1.000	.057	.041	.911**
	Sig. (1-tailed)	.170	.405	.012	.	.438	.462	.002
	N	8	8	10	10	10	8	7
Oestrogen	Correlation	-.611*	-.926**	.183	.057	1.000	-.378	.143
	Sig. (1-tailed)	.010	.000	.284	.438	.	.091	.329
	N	14	14	12	10	22	14	12
Progesterone	Correlation	.587	.822**	.395	.041	-.378	1.000	.029
	Sig. (1-tailed)	.063	.006	.167	.462	.091	.	.464
	N	8	8	8	8	14	14	12
Relaxin	Correlation	.239	-.426	.790*	.911**	.143	.029	1.000
	Sig. (1-tailed)	.303	.170	.017	.002	.329	.464	.
	N	7	7	7	7	12	12	12

Grey lines: Nonparametric Pearson. White lines: Parametric Pearson. Bolt numbers: Statistic significance. *: Pearson is significant at the 0.05 level (1-tailed). **: Pearson is significant at the 0.01 level (1-tailed). D: Dominant limb. nD: non-dominant limb. Cir: circumference. Sig: significance. N: sample size.

Correlation muscle structure – Hormonal concentration Ovulatory/Follicular										
		Muscle length	Muscle width	Muscle CSA	Fat thickness	St thickness	Lean	Oestrogen	Progesterone	Relaxin
Muscle length	Correlation	1.000	-.190	.058	-.001	.367	-.081	.599**	-.009	.460*
	Sig. (1-tailed)	.	.225	.404	.499	.056	.366	.004	.488	.049
	N	20	18	20	20	20	20	18	14	14
Muscle width	Correlation	-.190	1	.271	.384	-.121	.346	-.281	-.209	.004
	Sig. (1-tailed)	.225		.139	.058	.316	.080	.130	.237	.495
	N	18	18	18	18	18	18	18	14	14
Muscle CSA	Correlation	.058	.271	1	.207	.524**	.658**	.158	-.222	-.646**
	Sig. (1-tailed)	.404	.139		.191	.009	.001	.266	.223	.006
	N	20	18	20	20	20	20	18	14	14
Fat thickness	Correlation	-.001	.384	.207	1	.388*	.694**	.104	-.435	-.647**
	Sig. (1-tailed)	.499	.058	.191		.046	.000	.341	.060	.006
	N	20	18	20	20	20	20	18	14	14
ST thickness	Correlation	.367	-.121	.524**	.388*	1	.652**	.676**	-.612*	-.872**
	Sig. (1-tailed)	.056	.316	.009	.046		.001	.001	.010	.000
	N	20	18	20	20	20	20	18	14	14
Lean	Correlation	-.081	.346	.658**	.694**	.652**	1	.037	-.470*	-.881**
	Sig. (1-tailed)	.366	.080	.001	.000	.001		.442	.045	.000
	N	20	18	20	20	20	20	18	14	14
Oestrogen	Correlation	.599**	-.281	.158	.104	.676**	.037	1.000	-.192	-.491*
	Sig. (1-tailed)	.004	.130	.266	.341	.001	.442	.	.239	.027
	N	18	18	18	18	18	18	20	16	16
Progesterone	Correlation	-.009	-.209	-.222	-.435	-.612*	-.470*	-.192	1.000	.180
	Sig. (1-tailed)	.488	.237	.223	.060	.010	.045	.239	.	.269
	N	14	14	14	14	14	14	16	16	14
Relaxin	Correlation	.460*	.004	-.646**	-.647**	-.872**	-.881**	-.491*	.180	1

Sig. (1-tailed)	.049	.495	.006	.006	.000	.000	.027	.269	
N	14	14	14	14	14	14	16	14	16

Grey lines: Nonparametric Pearson. White lines: Parametric Pearson. Bolt numbers: Statistic significance. *: Pearson is significant at the 0.05 level (1-tailed). **: Pearson is significant at the 0.01 level (1-tailed). D: Dominant limb. nD: non-dominant limb. Cir: circumference. Sig: significance. N: sample size.

Correlation Flexibility – Hormonal concentration Ovulatory/Follicular

		ROM_{Max}	Torque_{Max}	FSS_{ROM}	FSS_{torque}	SMTU	Energy	Oestrogen	Progesterone	Relaxin
ROM_{Max}	Correlation	1	-.027	.526**	-.082	-.619**	-.480*	-.332	.387	.208
	Sig. (1-tailed)		.453	.006	.358	.001	.012	.077	.069	.220
	N	22	22	22	22	22	22	20	16	16
Torque_{Max}	Correlation	-.027	1	-.332	.430*	.528**	.298	-.100	-.045	-.285
	Sig. (1-tailed)	.453		.066	.023	.006	.089	.338	.435	.142
	N	22	22	22	22	22	22	20	16	16
FSS_{ROM}	Correlation	.526**	-.332	1	.168	-.612**	-.367*	.183	-.202	.285
	Sig. (1-tailed)	.006	.066		.227	.001	.047	.220	.226	.142
	N	22	22	22	22	22	22	20	16	16
FSS_{torque}	Correlation	-.082	.430*	.168	1.000	.270	.259	.463*	-.360	-.485*
	Sig. (1-tailed)	.358	.023	.227	.	.112	.122	.020	.085	.028
	N	22	22	22	22	22	22	20	16	16
SMTU	Correlation	-.619**	.528**	-.612**	.270	1.000	.784**	.254	-.271	-.781**
	Sig. (1-tailed)	.001	.006	.001	.112	.	.000	.140	.155	.000
	N	22	22	22	22	22	22	20	16	16
Energy	Correlation	-.480*	.298	-.367*	.259	.784**	1	.200	-.467*	-.512*
	Sig. (1-tailed)	.012	.089	.047	.122	.000		.199	.034	.021
	N	22	22	22	22	22	22	20	16	16
Oestrogen	Correlation	-.332	-.100	.183	.463*	.254	.200	1.000	-.192	-.491*
	Sig. (1-tailed)	.077	.338	.220	.020	.140	.199	.	.239	.027
	N	20	20	20	20	20	20	20	16	16
Progesterone	Correlation	.387	-.045	-.202	-.360	-.271	-.467*	-.192	1.000	.180
	Sig. (1-tailed)	.069	.435	.226	.085	.155	.034	.239	.	.269

	N	16	16	16	16	16	16	16	16	14
Relaxin	Correlation	.208	-.285	.285	-.485*	-.781**	-.512*	-.491*	.180	1
	Sig. (1-tailed)	.220	.142	.142	.028	.000	.021	.027	.269	
	N	16	16	16	16	16	16	16	14	16

Grey lines: Nonparametric Pearson. White lines: Parametric Pearson. Bolt numbers: Statistic significance. *: Pearson is significant at the 0.05 level (1-tailed). **: Pearson is significant at the 0.01 level (1-tailed). D: Dominant limb. nD: non-dominant limb. Cir: circumference. Sig: significance. N: sample size.

		Impulse	Force _{Peak}	Take-off velocity	Jump height	Total Impulse	Total Force _{peak}	Oestrogen	Progesterone	Relaxin
Impulse	Correlation	1	.483*	.505	.544*	.145	.394	-.012	-.042	-.110
	Sig. (1-tailed)		.011	.057	.042	.335	.115	.480	.439	.343
	N	22	22	11	11	11	11	20	16	16
Force _{Peak}	Correlation	.483*	1.000	-.136	-.210	-.355	.482	.002	-.024	-.509*
	Sig. (1-tailed)	.011	.	.345	.268	.142	.067	.497	.465	.022
	N	22	22	11	11	11	11	20	16	16
Take-off velocity	Correlation	.505	-.136	1	.985**	.818**	-.125	-.310	-.539	.000
	Sig. (1-tailed)	.057	.345		.000	.001	.358	.192	.084	.500
	N	11	11	11	11	11	11	10	8	8
Jump height	Correlation	.544*	-.210	.985**	1	.763**	-.061	-.494	-.434	.016
	Sig. (1-tailed)	.042	.268	.000		.003	.429	.073	.141	.485
	N	11	11	11	11	11	11	10	8	8
Total Impulse	Correlation	.145	-.355	.818**	.763**	1.000	.082	-.085	-.611	.071
	Sig. (1-tailed)	.335	.142	.001	.003	.	.405	.408	.054	.433
	N	11	11	11	11	11	11	10	8	8
Total Force _{peak}	Correlation	.394	.482	-.125	-.061	.082	1	-.578*	.275	-.392
	Sig. (1-tailed)	.115	.067	.358	.429	.405		.040	.255	.168
	N	11	11	11	11	11	11	10	8	8
Oestrogen	Correlation	-.012	.002	-.310	-.494	-.085	-.578*	1.000	-.192	-.491*
	Sig. (1-tailed)	.480	.497	.192	.073	.408	.040	.	.239	.027
	N	20	20	10	10	10	10	20	16	16

Progesterone	Correlation	-.042	-.024	-.539	-.434	-.611	.275	-.192	1.000	.180
	Sig. (1-tailed)	.439	.465	.084	.141	.054	.255	.239	.	.269
	N	16	16	8	8	8	8	16	16	14
Relaxin	Correlation	-.110	-.509*	.000	.016	.071	-.392	-.491*	.180	1
	Sig. (1-tailed)	.343	.022	.500	.485	.433	.168	.027	.269	
	N	16	16	8	8	8	8	16	14	16

Grey lines: Nonparametric Pearson. White lines: Parametric Pearson. Bolt numbers: Statistic significance. *: Pearson is significant at the 0.05 level (1-tailed). **: Pearson is significant at the 0.01 level (1-tailed). D: Dominant limb. nD: non-dominant limb. Cir: circumference. Sig: significance. N: sample size.

		Impulse	Force _{Peak}	Take-off velocity	Jump height	Total Impulse	Total Force _{peak}	Oestrogen	Progesterone	Relaxin
Impulse	Correlation	1	.506**	-.201	-.177	-.092	-.452	-.339	.083	.150
	Sig. (1-tailed)		.008	.277	.301	.394	.081	.072	.379	.290
	N	22	22	11	11	11	11	20	16	16
Force _{Peak}	Correlation	.506**	1.000	-.127	-.155	-.036	-.218	-.459*	.217	.201
	Sig. (1-tailed)	.008	.	.355	.325	.458	.260	.021	.209	.227
	N	22	22	11	11	11	11	20	16	16
Take-off velocity	Correlation	-.201	-.127	1	.990**	.978**	-.261	-.128	.216	-.457
	Sig. (1-tailed)	.277	.355		.000	.000	.219	.363	.304	.127
	N	11	11	11	11	11	11	10	8	8
Jump height	Correlation	-.177	-.155	.990**	1	.975**	-.281	-.177	.355	-.396
	Sig. (1-tailed)	.301	.325	.000	.000		.201	.313	.194	.166
	N	11	11	11	11	11	11	10	8	8
Total Impulse	Correlation	-.092	-.036	.978**	.975**	1	-.278	.043	.156	-.443
	Sig. (1-tailed)	.394	.458	.000	.000		.204	.454	.356	.136
	N	11	11	11	11	11	11	10	8	8
Total Force _{peak}	Correlation	-.452	-.218	-.261	-.281	-.278	1	.182	-.108	.196
	Sig. (1-tailed)	.081	.260	.219	.201	.204		.307	.400	.321
	N	11	11	11	11	11	11	10	8	8
Oestrogen	Correlation	-.339	-.459*	-.128	-.177	.043	.182	1.000	-.192	-.491*

	Sig. (1-tailed)	.072	.021	.363	.313	.454	.307	.	.239	.027
	N	20	20	10	10	10	10	20	16	16
Progesterone	Correlation	.083	.217	.216	.355	.156	-.108	-.192	1.000	.180
	Sig. (1-tailed)	.379	.209	.304	.194	.356	.400	.239	.	.269
	N	16	16	8	8	8	8	16	16	14
Relaxin	Correlation	.150	.201	-.457	-.396	-.443	.196	-.491*	.180	1
	Sig. (1-tailed)	.290	.227	.127	.166	.136	.321	.027	.269	
	N	16	16	8	8	8	8	16	14	16

Grey lines: Nonparametric Pearson. White lines: Parametric Pearson. Bolt numbers: Statistic significance. *: Pearson is significant at the 0.05 level (1-tailed). **: Pearson is significant at the 0.01 level (1-tailed). D: Dominant limb. nD: non-dominant limb. Cir: circumference. Sig: significance. N: sample size.

Correlation EMG – Hormonal concentration Ovulatory/Follicular								
		CMJ EMG _{RF}	CMJ EMG _{ST}	SJ EMG _{RF}	SJ EMG _{ST}	Oestrogen	Progesterone	Relaxin
CMJ EMG_{RF}	Correlation	1	.388	.224	.184	.549*	.237	-.414
	Sig. (1-tailed)		.085	.267	.331	.021	.230	.117
	N	14	14	10	8	14	12	10
CMJ EMG_{ST}	Correlation	.388	1.000	-.467	-.143	.350	.215	-.025
	Sig. (1-tailed)	.085	.	.087	.368	.110	.251	.473
	N	14	14	10	8	14	12	10
SJ EMG_{RF}	Correlation	.224	-.467	1.000	.345	.282	-.063	.812**
	Sig. (1-tailed)	.267	.087	.	.164	.187	.431	.007
	N	10	10	12	10	12	10	8
SJ EMG_{ST}	Correlation	.184	-.143	.345	1	-.202	.371	-.015
	Sig. (1-tailed)	.331	.368	.164		.287	.145	.486
	N	8	8	10	10	10	10	8
Oestrogen	Correlation	.549*	.350	.282	-.202	1.000	-.192	-.491*
	Sig. (1-tailed)	.021	.110	.187	.287	.	.239	.027
	N	14	14	12	10	20	16	16
Progesterone	Correlation	.237	.215	-.063	.371	-.192	1.000	.180

	Sig. (1-tailed)	.230	.251	.431	.145	.239	.	.269
	N	12	12	10	10	16	16	14
Relaxin	Correlation	-.414	-.025	.812**	-.015	-.491*	.180	1
	Sig. (1-tailed)	.117	.473	.007	.486	.027	.269	
	N	10	10	8	8	16	14	16

Grey lines: Nonparametric Pearson. White lines: Parametric Pearson. Bolt numbers: Statistic significance. *: Pearson is significant at the 0.05 level (1-tailed). **: Pearson is significant at the 0.01 level (1-tailed). D: Dominant limb. nD: non-dominant limb. Cir: circumference. Sig: significance. N: sample size.

Appendix N – Participant information form

Participant_information			
Participant_information	<input type="text" value="51"/>	For_how_long(contemporary)	<input type="text"/>
Participant_code	<input type="text"/>	National_dance	<input type="checkbox"/>
Study	<input type="text"/>	For_how_long(national)	<input type="text"/>
Name	<input type="text"/>	Other_dance_style(specify)	<input type="text"/>
Phone	<input type="text"/>	For_how_long	<input type="text"/>
Email	<input type="text"/>	Hours_dancing_pw	<input type="text"/>
Birthday	<input type="text"/>	Weight_lifting	<input type="checkbox"/>
Male	<input type="checkbox"/>	For_how_long(weight_lifting)	<input type="text"/>
Female	<input type="checkbox"/>	Aerobic	<input type="checkbox"/>
Taking_progesterone_only_CP	<input type="checkbox"/>	For_how_long(aerobic)	<input type="text"/>
Taking_combined_CP	<input type="checkbox"/>	Gymnastics_or_Martial_Arts	<input type="checkbox"/>
Coil	<input type="checkbox"/>	For_how_long(gymnastics)	<input type="text"/>
Implant	<input type="checkbox"/>	Yoga_Pilates	<input type="checkbox"/>
Not_taking_CP	<input type="checkbox"/>	For_how_long(yoga)	<input type="text"/>
Professional_dancer	<input type="checkbox"/>	Team_sports	<input type="checkbox"/>
Student_dancer	<input type="checkbox"/>	For_how_long(sports)	<input type="text"/>
Non_dancer	<input type="checkbox"/>	Other(specify)	<input type="text"/>
Height	<input type="text"/>	For_how_long(other)	<input type="text"/>
Parents_name	<input type="text"/>	Hours_other_activities_pw	<input type="text"/>
Parents_phone	<input type="text"/>	Have_you_had_injuries(last12months)	<input type="checkbox"/>
Parents_email	<input type="text"/>	Specify_where_what	<input type="text"/>
Classical_ballet	<input type="checkbox"/>	Other_injuries_during_the_carrier	<input type="checkbox"/>
For_how_long(ballet)	<input type="text"/>	Specify_what_where	<input type="text"/>
Jazz	<input type="checkbox"/>		
For_how_long(jazz)	<input type="text"/>		
Contemporary	<input type="checkbox"/>		

Appendix O – PASS 20 questionnaire

Please rate each item in terms of frequency, from 0 (Never) to 5 (Always).

Item Numbers	Never	Always
1. I can't think straight when in pain	0	5
2. During painful episodes it is difficult for me to think of anything besides the pain	0	5
3. When I hurt I think about pain constantly	0	5
4. I find it hard to concentrate when I hurt	0	5
5. I worry when I am in pain	0	5
6. I go immediately to bed when I feel severe pain	0	5
7. I will stop any activity as soon as I sense pain coming on	0	5
8. As soon as pain comes on I take medication to reduce it	0	5
9. I avoid important activities when I hurt	0	5
10. I try to avoid activities that cause pain	0	5
11. I think that if my pain gets too severe it will never decrease	0	5
12. When I feel pain I am afraid that something terrible will happen	0	5
13. When I feel pain I think I might be seriously ill	0	5
14. Pain sensations are terrifying	0	5
15. When pain comes on strong I think that I might become paralyzed or more disabled	0	5
16. I begin trembling when engaged in activity that increases pain	0	5
17. Pain seems to cause my heart to pound or race	0	5
18. When I sense pain I feel dizzy or faint	0	5
19. Pain makes me nauseous	0	5
20. I find it difficult to calm my body down after periods of pain	0	5

Appendix P – SEFIP questionnaire

- neck
- upper back
- elbows
- lower back
- hips
- thighs (back)

- shoulders
- wrists/hands
- thighs (front)
- knees
- shins
- calves
- ankles/feet
- toes

How do you feel just now?
 Do you have any musculoskeletal pain and/or ache right now (today), and in that case indicate below to what extent it disturbs your dance work. Look at the picture above to see the definitions for the body regions, and check one box for every body region, please.
 Thank you.

Very well

Some pain but not much problem

Pretty much pain but I can handle it

Much pain, must avoid some movements

Can not work in the production because of pain

Body region:	Estimation					Comments (optional):
neck	<input type="checkbox"/>	<input type="checkbox"/>	<input type="checkbox"/>	<input type="checkbox"/>	<input type="checkbox"/>	
upper back	<input type="checkbox"/>	<input type="checkbox"/>	<input type="checkbox"/>	<input type="checkbox"/>	<input type="checkbox"/>	
elbows	<input type="checkbox"/>	<input type="checkbox"/>	<input type="checkbox"/>	<input type="checkbox"/>	<input type="checkbox"/>	
lower back	<input type="checkbox"/>	<input type="checkbox"/>	<input type="checkbox"/>	<input type="checkbox"/>	<input type="checkbox"/>	
hips	<input type="checkbox"/>	<input type="checkbox"/>	<input type="checkbox"/>	<input type="checkbox"/>	<input type="checkbox"/>	
thighs (back)	<input type="checkbox"/>	<input type="checkbox"/>	<input type="checkbox"/>	<input type="checkbox"/>	<input type="checkbox"/>	
shoulders	<input type="checkbox"/>	<input type="checkbox"/>	<input type="checkbox"/>	<input type="checkbox"/>	<input type="checkbox"/>	
wrists/hands	<input type="checkbox"/>	<input type="checkbox"/>	<input type="checkbox"/>	<input type="checkbox"/>	<input type="checkbox"/>	
thighs (front)	<input type="checkbox"/>	<input type="checkbox"/>	<input type="checkbox"/>	<input type="checkbox"/>	<input type="checkbox"/>	
knees	<input type="checkbox"/>	<input type="checkbox"/>	<input type="checkbox"/>	<input type="checkbox"/>	<input type="checkbox"/>	
shins	<input type="checkbox"/>	<input type="checkbox"/>	<input type="checkbox"/>	<input type="checkbox"/>	<input type="checkbox"/>	
calves	<input type="checkbox"/>	<input type="checkbox"/>	<input type="checkbox"/>	<input type="checkbox"/>	<input type="checkbox"/>	
ankles/feet	<input type="checkbox"/>	<input type="checkbox"/>	<input type="checkbox"/>	<input type="checkbox"/>	<input type="checkbox"/>	
toes	<input type="checkbox"/>	<input type="checkbox"/>	<input type="checkbox"/>	<input type="checkbox"/>	<input type="checkbox"/>	
	<input type="checkbox"/>	<input type="checkbox"/>	<input type="checkbox"/>	<input type="checkbox"/>	<input type="checkbox"/>	

Appendix Q – Par-Q questionnaire

ParQ_you

Participant_code

1ParQ_you **1. Has your doctor ever said that you have a heart condition and that you should only do physical activity recommended by a doctor?**

2ParQ_you **2. Do you feel pain in your chest when you do physical activity?**

3ParQ_you **3. In the past month, have you had chest pain when you were not doing physical activity?**

4ParQ_you **4. Do you lose your balance because of dizziness or do you ever lose consciousness?**

5ParQ_you **5. Do you have a bone or joint problem (for example, back, knee or hip) that could be made worse by a change in your physical activity?**

6ParQ_you **6. Is your doctor currently prescribing drugs (for example, water pills) for your blood pressure or heart condition?**

7ParQ_you **7. Do you know of any other reason why you should not do physical activity?**

Appendix R – Example of menstrual cycle calendar filled

November 2016

Nº	Monday	Tuesday	Wednesday	Thursday	Friday	Saturday	Sunday
		1	2	3	4	5	6
44		Temperature: 36,2 Time: 12:00 Phase:	Temperature: 36,1 Time: 10:00 Phase:	Temperature: 36,5 Time: 8:00 Phase:	Temperature: 36,4 Time: 9:00 Phase:	Temperature: 36,2 Time: 10:00 Phase:	Temperature: 36,6 Time: 11:00 Phase:
	7	8	9	10	11	12	13
45	Temperature: 36,5 Time: 8:00 Phase:	Temperature: 36,2 Time: 8:00 Phase:	Temperature: 36,5 Time: 9:00 Phase:	Temperature: 36,7 Time: 8:30 Phase:	Temperature: 36,3 Time: 9:00 Phase:	Temperature: 36,1 Time: 10:00 Phase:	Temperature: 36,4 Time: 10:00 Phase:
	14	15	16	17	18	19	20
46	Temperature: 36,2 Time: 8:30 Phase:	Temperature: 36,5 Time: 8:00 Phase:	Temperature: 36,6 Time: 9:00 Phase:	Temperature: 36,1 Time: 8:30 Phase:	Temperature: Time: Phase:	Temperature: Time: Phase:	Temperature: Time: Phase:
	21	22	23	24	25	26	27
47	Temperature: Time: Phase:	Temperature: Time: Phase:	Temperature: Time: Phase:	Temperature: Time: Phase:	Temperature: 36,1 Time: 9 Phase:	Temperature: 36 Time: 10 Phase: P	Temperature: 36,2 Time: 11:00 Phase: P
	28	29	30				
48	Temperature: 36 Time: 8:00 Phase: P	Temperature: 36,3 Time: 9:00 Phase: P	Temperature: 36,1 Time: 8:10 Phase: P				

Appendix S – Visual Analogue Scale





Department of Exercise and Sport Science



Informed Consent Form

Name of Participant:

Supervisor/Principal Investigator: Bárbara Pessali-Marques

Project Title: The influence of menstrual cycle phase on flexibility and jump performance in dancers: interaction with MTU structural and functional characteristics.

Ethics Committee Approval Number: **22.12.15 (ii)**

Participant Statement

I have read the participant information sheet for this study and understand what is involved in taking part. Any questions I have about the study, or my participation in it, have been answered to my satisfaction. I understand that I do not have to take part and that I may decide to withdraw from the study at any point without giving a reason. Any concerns I have raised regarding this study have been answered and I understand that any further concerns that arise during the time of the study will be addressed by the investigator. I, therefore, agree to participate in the study.

It has been made clear to me that, should I feel that my rights are being infringed or that my interests are otherwise being ignored, neglected or denied, I should inform the Registrar and Clerk to the Board of Governors, Head of Governance and Secretariat Team, Manchester Metropolitan University, All Saints Building, All Saints, Manchester, M15 6BH, Tel: 0161 247 1390 who will undertake to investigate my complaint.

Signed (Participant)	<input type="text"/>	Date	<input type="text"/>
Signed (Investigator)	<input type="text"/>	Date	<input type="text"/>

Parental or guardian consent for research involving children.

I confirm that the details of this study have been fully explained and described in writing to (insert name) and have been understood by him/her and I, therefore, consent to his/her participation in this study.

Signed :	<input type="text"/>	Date :	<input type="text"/>
----------	----------------------	--------	----------------------

Please provide a contact number in case we need to get in touch with you.
Telephone

Appendix U – Participant information sheet

The influence of menstrual cycle phase on flexibility and jump performance in dancers:
interaction with MTU structural and functional characteristics
Ethics: 22.12.15 (u)



MANCHESTER METROPOLITAN UNIVERSITY
MMU Cheshire
Department of Exercise and Sport Science
Information Sheet for Participants
Title of Study:
The influence of menstrual cycle phase on flexibility and jump performance in
dancers: interactions with MTU structural and functional characteristics
Ethics Committee Reference Number:
22.12.15 (u)
Participant Information Sheet

1) This is an invitation to take part in a piece of research.
You are being invited to take part in a research study. Before you decide whether or not to take part, it is important for you to understand why the research is being done and what it will involve. Please take time to read the following information carefully and discuss it with others if you wish. Ask us if there is anything that is not clear or if you would like more information. Please take time to decide whether or not you wish to take part.

2) What is the purpose of the research?
The purposes of the study are to:

- 1) Determine if student dancers, elite dancers and non-dancers have the same structural and functional characteristics, to discover if their muscles respond in the same way during jump and flexibility exercises;
- 2) Determine if these characteristics are influenced by the different concentration of hormones during the phases of the menstrual cycle, and finally;
- 3) Determine if these muscle characteristics are influenced by the phases of the menstrual cycle, to find whether and how this can influence in jump and flexibility performance in dancers.

1

The influence of menstrual cycle phase on flexibility and jump performance in dancers:
interaction with MTU structural and functional characteristics
Ethics: 22.12.15 (u)

3) Why is the study being performed?
This study is being performed because we do not know the influence of different phases of menstrual cycle on the performance of movements like jumps and leg-holds. If the phases influence performance, we can use this information to guide dancers and other female athletes on how to conduct their training to optimize performance and minimize injury risks.

4) Why am I being asked to take part?
You are being asked to take part because you are female, you either have no formal dance background, or are a training/trained ballet dancer and are not taking a contraceptive pill or you are taking a combined contraceptive pill or you are taking a progesterone only contraceptive pill. In addition, you have had no injuries in the lower limb or low back in the last 6 months. Furthermore, you are aged 15 to 45 years, have no current health issues that may affect your ability to move without any pain or physical impediment. Finally, you are not taking any medication likely to affect your physical performance abilities.

5) Do I have to take part?
You are under no obligation to take part in this study. If, after reading this information sheet and asking any additional questions, you do not feel comfortable taking part in the study you do not have to. If you do decide to take part you are free to withdraw from the study at any point, without having to give a reason. If you do withdraw from the study you are free to take any personal data with you, on written request to the Principal Investigator, and this will not be included when the research is reported. If you decide not to take part or withdraw from the study, this will not affect your relationship with any of the staff at the Manchester Metropolitan University.

If you do decide to take part, you and your parent/guardian (when appropriate), will be asked to sign an informed consent form stating your agreement to take part. You will be given a copy of the consent form together with this information sheet to keep.

6) What will happen to me if I agree to take part?
If you agree to take part in this study, you will be invited to attend the Biomechanics Laboratory at Manchester Metropolitan University on the Crewe Campus on four separate occasions for approximately 4 hours each visit. On the first day, all the procedures will be explained in detail, so that you will be completely sure of them.

The following procedures will apply:

- 1) **Menstrual cycle calendar and body temperature:** Up to three months before the data collection, you will fill a calendar with your body temperature, the time, and highlight the dates of your period. The thermometer will be provided.
- 2) **Ovulation kit:** Using the menstrual calendar and the temperatures provided, your ovulation and the behaviour of your menstrual cycle will be recorded. You will then receive a urine kit 5 days before your predicted ovulation to find the ovulation phase. The ovulation kit is composed of five strips of urine test (One+Step, Germany), you should collect a urine sample in a clean and dry

2

- container (which will be provided) and place the test strip vertically into the urine sample for at least 10 seconds, you will remove the strip and place it on a clean and dry surface. Positive results may be visible after one minute through a coloured band, but to confirm the negative results, the full reaction time of 10 minutes is required. You have to repeat the test using one strip per day until the ovulation is confirmed. The next step is to call the researcher to book the tests.
- 3) **Forms about personal information:** You will be required to complete forms about personal information; any injuries suffered; the quantity and types of exercises that you practice; any pain you feel and how intense they are.
 - 4) **Anthropometry measurements:** Your body weight (balance), height (stadiometer), and percentage of fat (bio impedance), internal temperature (tympenic thermometer), circumferences and length of your limb segments (measuring tapes) will be measured. None of these measurements will cause any discomfort or pain.
 - 5) **Blood samples:** As the aim of this study is to evaluate the influence of menstrual cycle phases on performance, we have to repeat all the measurements in each one of the phases of the menstrual cycle. To know exactly which phase you are in, I have to take blood samples. These blood samples will be collected by a trained researcher from a vein in your arm. Once we have established the dates of your menstrual cycles phases you will be asked to come back to the laboratory to repeat all the measurements until all 3 phases have been evaluated. For the blood samples, you need to come to the laboratory after 12 hours of fasting, because of that, the research sessions will happen early in the morning. Breakfast will be provided after the samples being collected.
 - 6) **Ultrasound measurements of your thigh muscles and tendons:** You will lie on a physiotherapy bed, facing down, with your thighs and lower legs exposed in a way that your hamstrings can be measured. The ultrasound, which is a medical scanning tool, has an instrument called a probe, which is then covered with a hypo-allergenic gel. Once covered in gel, the probe is placed on the back of your thigh to obtain the images required to characterize your muscles and tendons. This assessment causes no pain or discomfort.
 - 7) **Arrixation of the electrodes and markers for the video analyses:** The electrodes are adhesive patches placed on the skin to measure the electrical activity of the muscle. To enable the electrodes to be attached, your leg will be shaved and cleaned with alcohol. The marks for the video analyses are adhesive too, but for them we do not need to shave the skin.
 - 8) **Familiarization with vertical jump tests:** You have to do 3 jumps of two different technique in the data collection day, however, during the familiarization you can try as many times as needed until you be able to execute 3 similar jumps. The techniques are the countermovement jump and the squat jump and they are generally executed in many sports and physical activities. In the countermovement jump, you will be positioned above a force platform, standing in vertical position with parallel feet, hands on the hips and looking forward. You will flex your knee and hip immediately before the jump. In the squat jump, you will be in the same initial position and above the force platform as in the previous jump. However, you will assume a hip and knee flexion about 90° (the researcher will tell you to stop the knee and hip flexion when you reach this position) and hold this position for three seconds before the jump.
 - 9) **Flexibility assessment:** You will be standing in a vertical position with parallel feet, hands on the hips and looking forward. The equipment has arms that follow your lower limb when you flex or extend the hip measuring the range of motion

3

- of this joint. For that, one of your ankle will be attached to the equipment arm with a Velcro strap. As in the jump familiarization, you can repeat the measurements as many times as you need to learn the pattern of movement, and to feel comfortable during the tests. The electrodes will be connected at the computer and the entire test will be recorded.
- 10) **Passive flexibility:** The passive flexibility will also be measured in an equipment that its arm follow the movement of your hip or knee measuring the range of motion. However, for this evaluation you will be laid down on your back on the equipment table, with the arm of the equipment attached to your ankle. Straps at your thighs, pelvis, and chest will attach you to the equipment. You will receive two controls, one to move the equipment arm up and down and the other to press when you start to feel a tension (the beginning of stretching) in the hamstring. The equipment arm moves slowly (5°/s) and you have to stretch until the maximum tolerated by you. This procedure is done to evaluate your maximal range of motion. After that, 4 series of stretches with 90% of your maximal range of motion for 30 seconds will be done. The equipment will not go further than the maximum established by you, also, if you stop to press the button the arm of the equipment stops immediately.
 - 11) **Ice Water Test (IWT):** Your dominant arm (up to the elbow) will be immersed in a 37-39 degrees Celsius (body temperature) water for 120 seconds; then the same arm will be immersed in a -3 to 0 degrees Celsius until the maximum time that you can tolerate the cold, for a maximum duration of 120 seconds. Every 20 seconds you will be asked about any discomfort and to describe your sensation.

7) Are there any disadvantages or risks in taking part?

The stretching and the Ice Water Test could be uncomfortable as the aim of both tests is reach the maximum tolerated by you. However, the risks of taking part of this study are very low, once the all the movements are supervised by the researcher that will correct any technique and control the maximum stretch reached in the equipment. This way, the possible injury risks, such as muscle strains due the stretching or twists of lower limb due to jumps because of bad technique will be minimized. Muscle soreness also can be felt after jumping and flexibility tests, but it is not indicative of an injury and this soreness will disappear within 12 to 48 hours. Bruises can also happen due to the venipuncture. They are normal and happen when a small bleeding occur under the skin.

8) What are the possible benefits of taking part?

Taking part of this study you are contributing for the development of training strategies to improve performance and decrease injury risk in dancers population. Also, the results of this study can be extrapolated to other sports and activities practiced by women. Individually you will be informed about how to conduct your training during the phases of the menstrual cycle and will receive a screening of you performance and physical capabilities.

9) Who are the members of the research team?

Bárbara Pessali Marques is the principal investigator of this PhD research. If further information is needed you can contact by the e-mail b.pessali-marques@mmu.ac.uk or by the number 1612475033, Seeley building 1-16. Other members of the research

4

team include Dr Gladys Onambe-Pearson - g.pearson@mmu.ac.uk, Director of studies; as well as the co-supervisors Dr Adrian Burden and Dr Christopher Morse.

10) Who is funding the research?

The Brazilian Government - CAPES Foundation, is founding the principal investigator for this research. The research laboratory facilities and consumables are generously provided through the (1) Department of Exercise and Sport sciences, and (2) the Health exercise & Active Living Research Centre, at the Manchester Metropolitan University.

11) Who will have access to the data?

All information collected during the course of the research will be kept confidential and will only be used for the purposes of the study. The data will be stored in anonymous or coded form at the point of data collection and just the research team will have access to it. The data will be kept for up to 3 years after completion of the program of PhD research, and after that it will be destroyed.

The results of the study are likely to be communicated at conferences or published in scientific journals at some point in the future but in a manner that does not allow an individual's identity to be determined. In addition, you may obtain a copy of any publication that result from this research.

12) Who do I contact if I feel my rights have been violated?

If you wish to make a complaint regarding their involvement in the study you can contact the MMU Ethics Committee:

MMU Ethics Committee
Registrar & Clerk to the Board of Governors
Head of Governance and Secretariat Team
Manchester Metropolitan University
All Saints Building, All Saints
Manchester M15 6BH
Tel: 0161 247 1390

Also include the following statement :

I confirm that the insurance policies in place at Manchester Metropolitan University will cover claims for negligence arising from the conduct of the University's normal business, which includes research carried out by staff and by undergraduate and postgraduate students as part of their course. This does not extend to clinical negligence.

13) Finally, a thank you!

Your participation in this study has a priceless value. Thank you considering to make a contribution to development of science, and even more of dance science.

ESS Ethics Stage 1 ISP form. Use this ISP form for all Stage 1 applications from March 2015 onwards.