

18-Pulse Rectifier with Electronic Phase Shifting and Pulse Width Modulation

E. Sokol, V. Zamaruev, V. Ivakhno, Yu. Voitovych, O. Butova, V. Makarov
 Department of Industrial and Biomedical Electronics
 National Technical University of Ukraine "Kharkiv Polytechnic Institute"
 Kharkiv, Ukraine
 VoitovychYS@gmail.com

Abstract - At present, 12-pulse rectifiers with electronic phase shift are known. Unlike classic rectifiers, they do not use phase-shifting transformers and have a unit power factor. Increasing of the rectifier's pulse makes it possible to improve the harmonic composition of the input current. This article is devoted to the study of the operation of an 18-pulse rectifier with an electronic phase shift. The use of the principle of electronic phase shift leads to different levels of constant voltage at the output of the rectifiers. The introduction of pulse-width modulation contributes to equalizing the output voltages of the 6-pulse rectifiers which are the parts of the converter. In addition, the use of the pulse-width modulation allows eliminating matching magnetic elements which are used to equalize rectifiers output voltages. This improves the mass and dimension parameters of the converter. The results of modeling are presented.

Keywords: rectifiers, power factor, electronic phase shifting, pulse-width modulation, magnetic elements.

I. INTRODUCTION

At present, with the development of semiconductor devices, there is a tendency to minimize magnetic elements or to completely abandon their use. This is especially true in power electronics. Magnetic elements typically have the greatest mass and dimension parameters as compared with semiconductor elements forming a main part of a converter device [1].

For the operation of a classical three-phase more than 6-pulse rectifier, phase-shifting transformers or autotransformers are used [2, 3]. For higher-pulse rectifier configuration (more than 12-pulse) phase-shifting magnetic elements complicate their construction [4, 5].

Exclude phase-shifting transformers for 12-pulse rectifiers was proposed in [6, 7]. In this case, the phase shift is realized by means of the rectifier itself (electronic phase shift).

When developing power converters, it is necessary to take into account the requirements for the quality of the consumed electricity. The quality parameters include the limitation of the harmonic composition and the total harmonic distortion of the consumed current (THD_i) [8], the power factor, etc.

To correspond the quality requirements, converters with a

power factor correction (PFC) function can be used as rectifiers [9, 10, 11, 12]. However, usually, these converters use pulse-width modulation (PWM) and introduce significant distortion of the consumption current at PWM frequency and its harmonics [11, 12]. The disadvantages of these converters are include large dynamic losses in semiconductor switches. It is also necessary to take into account the features of magnetic elements that operate at high frequencies.

The article deals with the use of an 18-pulse rectifier with an electronic phase shift. The electronic phase shift makes it possible to obtain a power factor of the converter close to unity without using of phase-shifting transformers. Introduction of low-frequency PWM makes it possible to abandon the matching autotransformers. In contrast to the PFC with a high frequency PWM, the switching frequency of 18-pulse rectifier's switches is equal to the frequency of the network or twice more it when using PWM and eliminating matching autotransformers. Low PWM frequency minimizes dynamic losses. Increasing the pulse numbers, allows to improve the harmonic composition of the consumed current.

II. REALIZATION OF AN 18-PULSE RECTIFIER WITH ELECTRONIC SHIFT PHASES

A. Principles of constructing an 18-pulse rectifier

To obtain minimum harmonic distortion of the input current, it is advisable to increase the pulse numbers of the rectifier [6]. The most significant reduction of THD_i has a transition from a 6-pulse to a 12-pulse circuit, but THD_i remains above the 15% limit defined in [8]. The transition to a 18-pulse rectifier circuit allows to overcome the limitations of 15% and 12%. A further increase the pulse of the rectifier to 24 makes it possible to approach close to the 8% boundary whereas the converter circuit becomes more complicated [13]. Consider an 18-pulse inverter with inductive load [2, 6] that meets the requirements of most consumers. To obtain a minimum THD_i, the phase difference between the rectifier currents should be 20 electrical degrees. To obtain a unite power factor, the rectifier currents must be symmetrical with respect to the line voltage [6, 7, 12], as shown in Fig. 1 for the U_{AB} case. The first rectifier should work with a control angle of +20 electrical degrees, the second – with a zero phase shift, and the third – with a control angle of -20 electrical degrees.

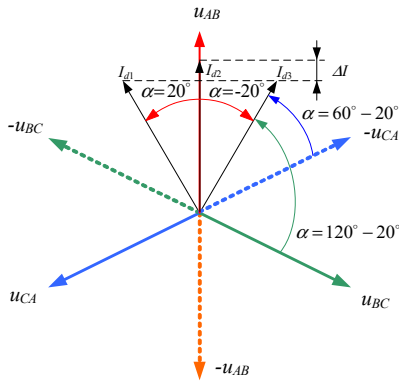

Fig. 1. Vector diagram of 18-pulse rectifier with electronic phase shift

As switches of first rectifier, can be used thyristors, the second – diodes, the third – completely controlled switches with reverse blocking capability. The functional diagram of the 18-pulse converter is given in Fig. 2.

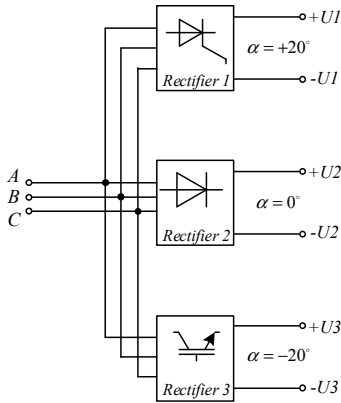

Fig. 2. Functional diagram of the 18-pulse converter with electronic phase shift

In this case, the output voltages, and, consequently, the currents of the rectifiers will ($I_{d1}=I_{d3}<I_{d2}$), which is due to the operation of rectifiers with different control angles. This problem can be solved by introducing a matching step-up autotransformer for rectifiers with control angles of ± 20 electrical degrees. (Fig. 3). A step-down matching autotransformer for a rectifier with zero control angle can also be used (Fig. 4).

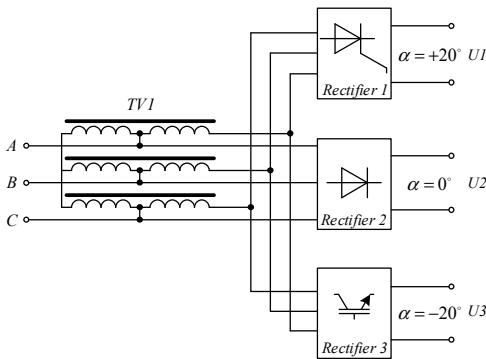

Fig. 3. The scheme of 18-pulse rectifier with step-up matching transformer

The transformation ratio is chosen taking into account the alignment of the average output voltages of the rectifiers. The installed capacity of the transformers is 4% and 2% of the load power, respectively.

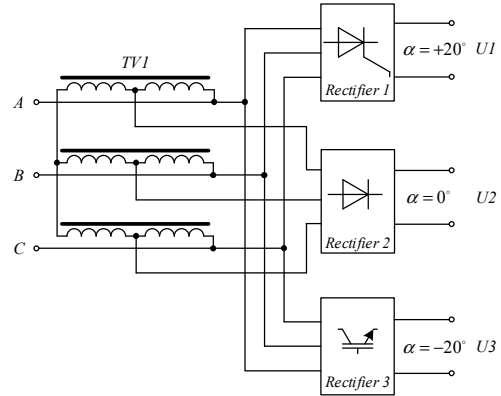

Fig. 4. The scheme of 18-pulse rectifier with a step-down matching transformer

The use of matching autotransformers leads to a deterioration in the mass and dimension parameters of the converter. Estimated mass for a 90 kW total load are: for a step-up autotransformer is 23 kg, for a step-down autotransformer is 14 kg.

B. Implementation of electronic phase shift with PWM

To exclude matching autotransformers, it is proposed to introduce PWM of the voltage in the rectifier operating with zero control angle. When replacing diodes in the uncontrolled Rectifier2 (Fig. 2) to fully controllable switches, it becomes possible to abandon a matching autotransformer and reduce the output voltage of the rectifier by limiting the conductivity time of the switches. In the basic rectifier circuit (Fig. 5) it is advisable to use IGBT with reverse blocking capability.

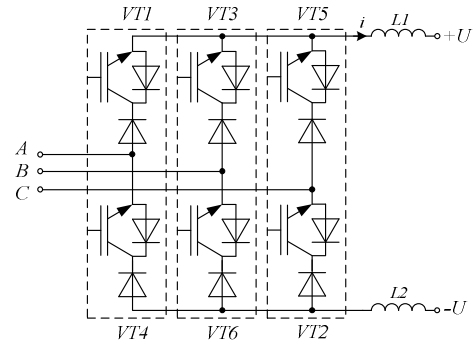

Fig. 5. Basic circuit of rectifier

To avoid the appearance of a phase shift of the Rectifier2 input current relative to the supply voltage, it is necessary to use a symmetric limitation of the conduction time of the switches, which is one of the types of the pulse-width modulation. So for the VT_1 of the anode group conducting the current of phase A, the conduction time is shortened from the interval tk_1-tk_3 to the interval t_1-t_4 (Fig. 6).

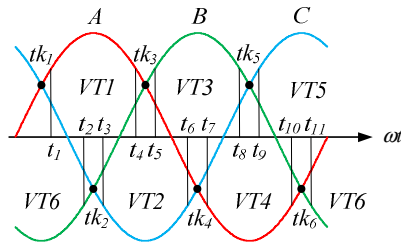

Fig. 6. The simplest switch algorithm

For practical implementation of the simplest switching algorithm (Fig. 6) must be modified. This is due to the inadmissibility of interrupting the current of the chokes L_1 and L_2 (Fig. 5). On time intervals t_2-t_3 , t_4-t_5 etc. at the same time as the input rectifier current is interrupted, the path of its output current must be provided. This can be realized by turning on the second switch in the rectifier's arm with conducting switch (VT_4 on the interval t_2-t_3 , VT_5 on the interval t_4-t_5 etc. (Fig. 5, Fig. 6)). In some cases, in the circuit (Fig. 5), can be introduced diode that shunt DC terminals of the rectifier bridge. With the shunt diode no additional switching on the transistor is required, the output current at the switch-off intervals is closed via a diode VD_1 (Fig. 7), but properties of this circuit are significantly different than base circuit (Fig. 5).

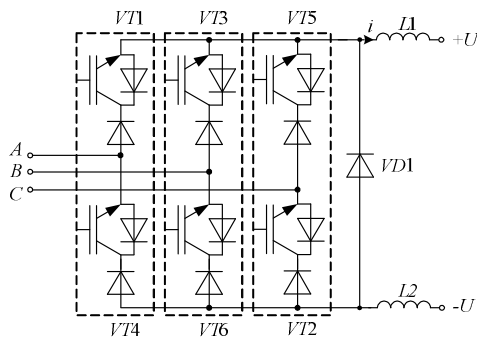

Fig. 7. Modified circuit of rectifier

The energy transfer to the load occurs at intervals t_1-t_2 , t_3-t_4 , t_5-t_6 and so on (Fig. 8).

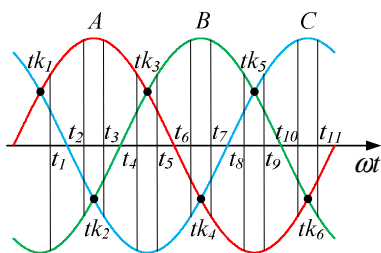

Fig. 8. Switching algorithm and energy transfer intervals

The current flow in the circuit Fig. 7 is represented by Fig. 9.

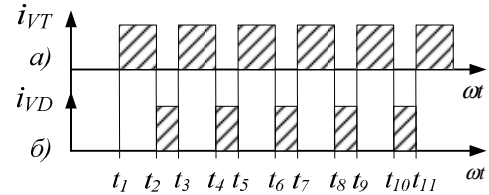

Fig. 9. a) current of controlled switches; b) current of diode

Control angles of switches corresponding to the time intervals – $t_{k1}-t_{l1}$, t_2-t_{k2} , $t_{k2}-t_3$ etc. can be determined based on a comparison of decrease the average rectified voltage with the selected control algorithm and the rectified voltage without regulation. The relative decrease of voltage can be calculated by (1), where α – the control angle of the switches (in electrical degrees). A symmetrical PWM is used with a period of 60 electrical degrees.

$$\text{int}(\alpha, t) = \frac{\frac{\pi}{2} - \frac{\pi\alpha}{180}}{\frac{\pi}{2}} \frac{\int_{0+\frac{\pi}{6}}^{\frac{\pi}{2}} \sin(t) dt}{\int_{0+\frac{\pi}{6}}^{\frac{\pi}{2}} \sin(t) dt} \quad (1)$$

The results of the calculations are given in Fig. 10.

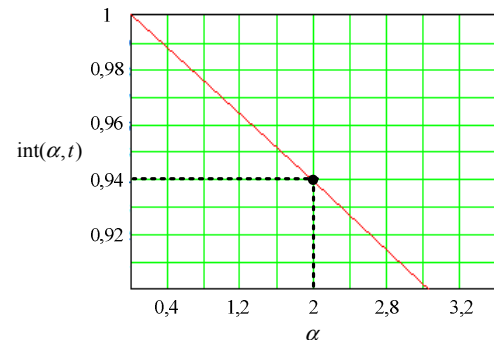

Fig. 10. Dependence of the relative voltage drop of the control angle

To 6% reduce a rectified voltage requires the control angle of 2 electrical degrees.

C. 18-pulse rectifier with electronic phase shift

Using in 18-pulse rectifier (Fig. 2) of the rectifier unit on a semi-controlled switches (thyristors) leads to differences in the switching processes in this and other rectifiers. These differences lead to the appearance of asymmetry in the input currents of the rectifiers and an increase THD₁. The asymmetry can be eliminated either by control means or by using identical power units (Fig. 5) in all rectifiers. The functional diagram of the converter gets the form shown in Fig. 11. Current distribution between rectifier1 to rectifier3 is provided by rectifiers' control systems. In this converter agreed control between rectifiers is used.

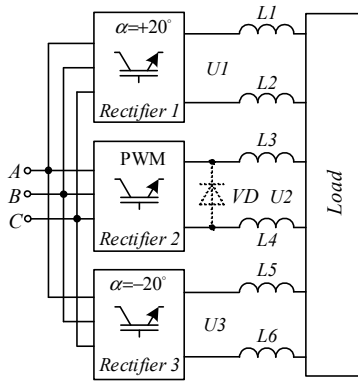

Fig. 11. Functional scheme of 18-pulse converter with electronic phase shift

The load of the converter can be either typical (Fig. 12), or multi-channel (Fig. 13). Proposed converter is suitable for symmetrical multi-channel loads. With equal load in different channels, the converter, from the point of view of the mains, remains an 18-pulse rectifier with a conventional inductive load.

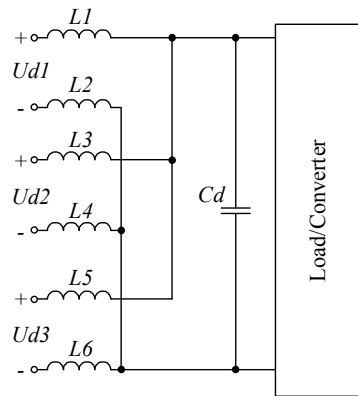

Fig. 12. The single-channel load of 18-pulse converter

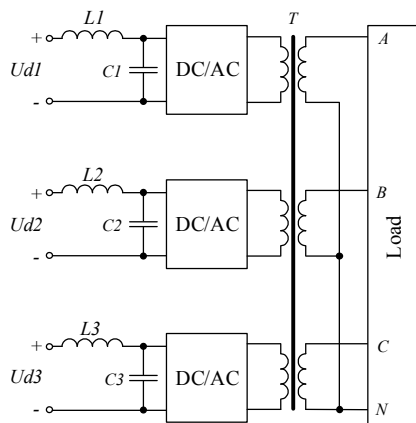

Fig. 13. The multi-channel load of 18-pulse converter

Some converters can be easily adapted to the multichannel load mode. For example, airport ground power units manufactured by ITW GSE [14] and «Estel» AS [15] use one constant voltage source to power inverter 3x115V 400Hz [16]. Since the load of the inverters is galvanically isolated, the

power supply of the inverters can be realized via a multichannel circuit.

III. RESULTS OF MODELING

Simulation of an 18-pulse converter with electronic phase shift and PWM was performed on the model in accordance with the functional scheme of Fig. 11 and multi-channel load (Fig. 13). The total load power is 90 kW. The DC current pulsations do not exceed 0.5 A.

The simulation results, such as output voltages and rectifier currents are shown in Fig. 14 and Fig. 15. It can be seen that the results correspond to the expected results.

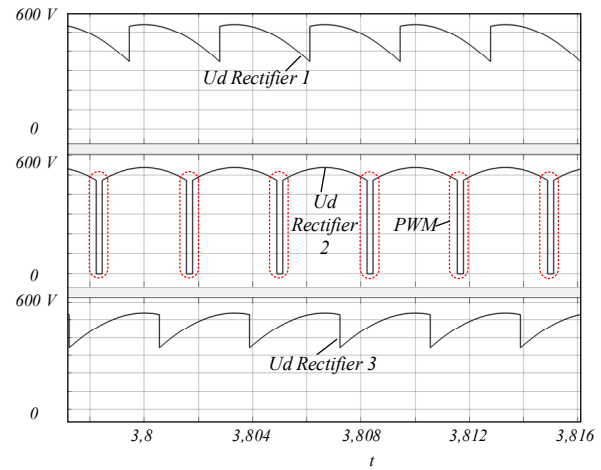

Fig. 14. Oscillograms of rectified voltages in 18-pulse rectifier with electronic phase shift

Without additional regulation and the same load of channels, the rectified voltages are $U_{dRectifier}=481$ V (Fig. 14) and the currents of one load channel is $I_{dRectifier}=62,9$ A (Fig. 15).

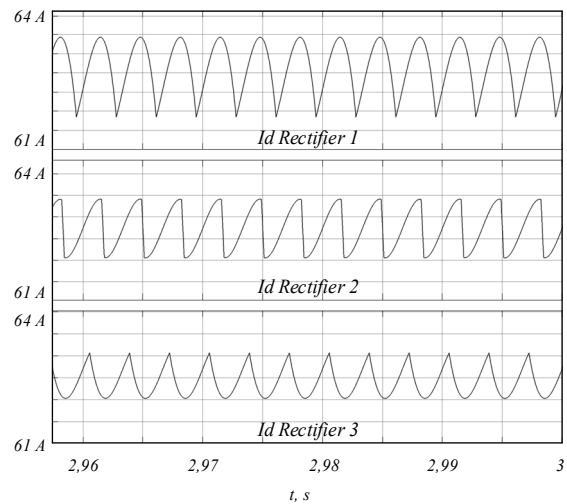

Fig. 15. Oscillograms of rectified rectifier currents included in an 18-pulse rectifier with electronic phase shift

In Fig. 16 shows the computer diagrams of the phase

voltages of the mains and the input phase currents of the simulated converter.

The use of positive and negative control angles of rectifier1 and rectifier3 and a symmetrical limitation of the conductivity time of rectifier's2 switches, made it possible to obtain input currents of rectifiers symmetric with respect to the voltage of the mains. This provided the zero phase shift of the input current and voltage – a unit power factor of the converter.

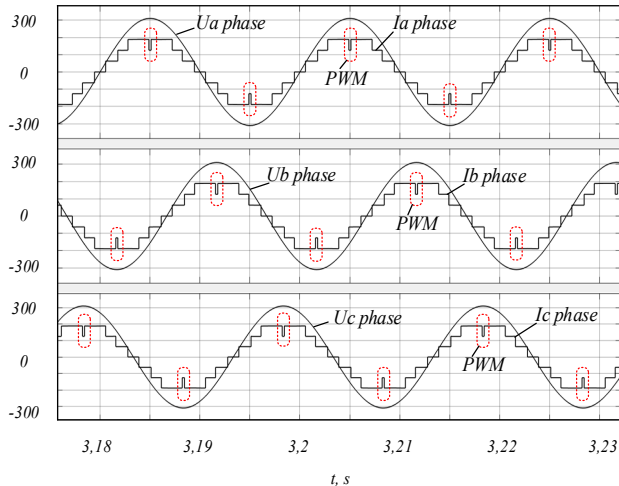

Fig. 16. Oscillograms of the input phase currents of the 18-pulse converter operating in the rated load mode without input filters

In comparison with the converter with a matching autotransformer ($THD_I=10.68\%$) the increase of THD_I of the input current was 2.84% .

IV. CONCLUSION

The use of electronic phase shifting provides a unit power factor of 18-pulse converter.

The use of PWM in the rectifier channel with zero control angle, makes it possible to exclude matching autotransformers (step-up or step-down) with an insignificant deterioration of THD_I of the input current.

Symmetric limitation of the conduction time of the switches and using positive and negative control angles of rectifiers are made it possible to obtain rectifier input currents symmetric with respect to the voltage of the mains and a power factor close to unity.

REFERENCES

- [1] Ivakhno, V., V. Zamaruev, B. Styslo, R. Kosenko, and A. Blinov. 2017. "Bidirectional Isolated ZVS DC-DC Converter with Auxiliary Active Switch for High-Power Energy Storage Applications." doi:10.1109/UKRCON.2017.8100315.
- [2] B. Wu, M. Narimani, "High-power converters and ac drives," Wiley-IEEE Press, 2017. DOI:10.1002/9781119156079
- [3] S. Choi, P. N. Enjeti, I. J. Pitel, "Polyphase transformer arrangements with reduced kVA capacities for harmonic current reduction in rectifier-type utility interface," in IEEE Transactions on Power Electronics, vol. 11, no. 5, pp. 680-690, Sep 1996. DOI: 10.1109/63.535400
- [4] IEEE Guide for the Application, Specification, and Testing of Phase-Shifting Transformers," in IEEE Std C57.135-2011 (Revision of IEEE Std C57.135-2001) , vol., no., pp.1-50, Aug. 19 2011 DOI: 10.1109/IEEESTD.2011.5993462
- [5] G. L. Skibinski, N. Guskov and Dong Zhou, "Cost effective multi-pulse transformer solutions for harmonic mitigation in AC drives," 38th IAS Annual Meeting on Conference Record of the Industry Applications Conference, 2003., 2003, pp. 1488-1497 vol.3. DOI: 10.1109/IAS.2003.1257753
- [6] D.A. Paice Power Electronics Converter Harmonics: Multipulse Methods for Clean Power Wiley-IEEE Press, 1996. DOI: 10.1109/9780470545560
- [7] Y. B. Blauth and I. Barbi, "A phase-controlled 12-pulse rectifier with unity displacement factor without phase shifting transformer," Applied Power Electronics Conference and Exposition, 1998. APEC '98. Conference Proceedings 1998., Thirteenth Annual, Anaheim, CA, 1998, pp. 970-976 vol.2. DOI: 10.1109/APEC.1998.654016
- [8] IEEE Std 519TM-2014, IEEE Recommended Practice and Requirements for Harmonic Control in Electric Power Systems" (Revision of IEEE Std 519-1992), 2014.
- [9] M.H. Rashid, "Power Electronics Handbook," 3rd ed., Boston: Elsevier Inc., 2011.
- [10] F.L. Luo, H. Ye, "Power Electronics: Advanced Conversion Technologies," CRC Press, Boca Raton, p. 745, 2010.
- [11] W. Hu, A. Yu, J. Lyu, H. Ding and J. Lyu, "Research on reducing the input current distortion based on PWM method for Vienna rectifier with LCL filter," 2017 Chinese Automation Congress (CAC), Jinan, 2017, pp. 6634-6639. DOI: 10.1109/CAC.2017.8243972
- [12] Yungtaek Jang and M. M. Jovanovic, "A comparative study of single-switch three-phase high-power-factor rectifiers," in IEEE Transactions on Industry Applications, vol. 34, no. 6, pp. 1327-1334, Nov/Dec 1998. DOI: 10.1109/28.739018
- [13] Y.I. Sokol, V.V. Zamaruev, V.V. Ivakhno, Yu.S. Voitovych Electronic Phase Shifting in Multipulse Rectifier// Electrical, Control and Communication Engineering, The Journal of Riga Technical University, 2017, vol.12, pp.5-10. DOI: 10.1515/ecee-2017-0001.
- [14] <http://itwgse.com/power/>
- [15] <http://tet-estel.com/products/aviation/kombinirovannyj-istochnik-pitaniya-fcaar/>
- [16] 2400-Series, 30 - 90 kVA Main Circuit and Instrumentation <http://itwgse.com/wp-content/uploads/2018/03/478101db.pdf>