

HENRY

Hydraulic Engineering Repository

Ein Service der Bundesanstalt für Wasserbau

Conference Paper, Published Version

Keramaris, Evangelos; Panayotis, P.

Gravity currents in a valley of trapezoidal shape

Verfügbar unter/Available at: <https://hdl.handle.net/20.500.11970/99695>

Vorgeschlagene Zitierweise/Suggested citation:

Keramaris, Evangelos; Panayotis, P. (2010): Gravity currents in a valley of trapezoidal shape. In: Dittrich, Andreas; Koll, Katinka; Aberle, Jochen; Geisenhainer, Peter (Hg.): River Flow 2010. Karlsruhe: Bundesanstalt für Wasserbau. S. 599-604.

Standardnutzungsbedingungen/Terms of Use:

Die Dokumente in HENRY stehen unter der Creative Commons Lizenz CC BY 4.0, sofern keine abweichenden Nutzungsbedingungen getroffen wurden. Damit ist sowohl die kommerzielle Nutzung als auch das Teilen, die Weiterbearbeitung und Speicherung erlaubt. Das Verwenden und das Bearbeiten stehen unter der Bedingung der Namensnennung. Im Einzelfall kann eine restriktivere Lizenz gelten; dann gelten abweichend von den obigen Nutzungsbedingungen die in der dort genannten Lizenz gewährten Nutzungsrechte.

Documents in HENRY are made available under the Creative Commons License CC BY 4.0, if no other license is applicable. Under CC BY 4.0 commercial use and sharing, remixing, transforming, and building upon the material of the work is permitted. In some cases a different, more restrictive license may apply; if applicable the terms of the restrictive license will be binding.



Gravity Currents in a Valley of Trapezoidal Shape

Keramaris Evangelos

Department of Civil Infrastructure Eng., TEITh, Sindos, 57400 Thessaloniki, Greece

Prinos Panayotis

Department of Civil Infrastructure Eng., AUTH, 54124 Thessaloniki, Greece

ABSTRACT: In this study the motion of saline gravity currents is investigated in lock-exchange experiments which are carried out in a tank of rectangular upper cross section and a lower valley of trapezoidal shape. This is considered as a realistic model of the valleys which occur in nature. The experiments are performed for equal depths of heavy and light fluid on both sides of the lock gate. Gravity current is generated, due to the horizontal density gradient, after the removal of the partition. The heavier fluid propagates towards the lighter fluid reservoir along the bottom of the tank and the lighter fluid propagates along the free surface in the opposite direction. Density difference between salt water and clear water is varied between 0.1 % and 0.4 % and hence the effect of density difference on the motion of the gravity currents is also investigated. The movement of the gravity current is monitored with a digital video of high definition, the front velocity is measured and the height of the front is captured. Twenty four experiments were performed twelve inside the trapezoidal section ($H=4, 6$ or 8 cm) and twelve over the trapezoidal section ($H=12, 14$ or 16 cm). The initial Reynolds number, based on the height of the valley and the reduced gravity, is greater than 10000 for all cases indicating that the gravity currents are turbulent. Results are compared with those of gravity currents in simple rectangular tanks as well as with similar experiments in V-shaped valleys performed by Monaghan et al. (2009).

Keywords: Gravity currents, Lock-Exchange, Front Velocity, Valley, Trapezoidal

1 INTRODUCTION

The environmentally important problem of gravity current motion in an open channel has been investigated theoretically and experimentally. The lock-exchange flows have used for studying the behaviour of gravity currents.

Such currents can be easily reproduced in the laboratory through a lock-exchange experiment in which a laboratory tank is divided in two reservoirs, filled with fluids at different densities, by installing a removable partition. When the partition is removed, the horizontal density gradient generates an exchange flow. The heavier fluid propagates toward the lighter fluid reservoir along the bottom of the tank and the lighter fluid propagates along the free surface in the opposite direction (Simpson, 1997).

Initially Benjamin (1968) studied the classic lock exchange has negligible dissipation and its inertia dominated. It exhibits a predominantly horizontal interface that curves sharply toward the

free surface and the bed at the leading edges of the surface current and undercurrent, respectively.

Shin et al. (2004) described a new theory and experiments on gravity currents produced by lock-exchange which suggested that the dissipation due to turbulence and mixing between the current and the surrounding ambient fluid is unimportant when the Reynolds number is sufficiently high. They provided an alternative theory that predicts the current speed and depth based on energy-conserving flow.

A related problem which has been studied experimentally is the flow of gravity currents down rumps into a horizontal surface. There has been much less research on gravity currents flowing along valleys.

Antenucci et al. (2005) have studied a constant flux flow along a V-shaped channel into a reservoir to model the spread of pathogens. Constant flux currents along sinuous channels have been investigated using saline current to model turbidity currents (Keevil et al., 2006).

Takagi and Huppert (2007) examined Newtonian viscous gravity currents propagating along horizontal and inclined channels with semicircular and V-shaped boundaries. The mathematical equations are compared with data from laboratory experiments. Geological applications of the results are discussed.

Also Takagi and Huppert (2008) used a model of unidirectional Stokes flow on rigid surfaces to obtain a variety of different propagation rates of viscous gravity currents, which arise by considering different releasing rates at the source inside channels that change shape down the flow. Also the position of a current inside either an extremely narrow or nearly V-shaped channel that gently widens along the flow is studied and shown to be proportional to a power of time.

Monaghan et al. (2009a) investigated the motion of saline gravity currents propagating horizontally in a tank of rectangular upper cross section and lower V-shaped valley by lock-exchange experiments and a box model. The presence of valley results in three major differences in the gravity current compared to that flowing along a flat bottom. These are : i) the front of the current is approximately parabolic ii) for sufficiently large time t the velocity of the current in the V-shaped valley varies in the flat bottom case and iii) the width of the current in V-shaped valley decreases with time t . They have used the box model to predict the effect of changing the slope of the valley after obtaining good agreement between experiments and box model results. The result is that for equal volume currents, the steeper the valley the faster the flow.

Also Monaghan et al. (2009b) in their paper extended previous studies of saline gravity currents at high Reynolds number flowing along a tank with a V-shaped valley. They used experiments and a box model to determine the primary features of the flow. The front of the current is approximately parabolic. The results can be described with remarkable accuracy by a box model using a generalization of the equation for sedimentation from a turbulent medium.

Finally Marino and Thomas (2009) studied the variation of the Froude number at the front of gravity currents developed in uniform channels whose cross-section shape depends on a parameter usually used in many numerical and theoretical models. The relationships obtained agree with the results of laboratory experiments in which open and closed channels of different cross-section shapes are used.

In this study the motion of saline gravity currents is investigated in lock-exchange experiments which are carried out in a tank of rectangular upper cross section and a lower valley

of trapezoidal shape. This is considered as more realistic model of the valleys which occur in nature. The experiments are performed for equal depths of heavy and light fluid on both sides of the lock gate. Gravity current is generated, due to the horizontal density gradient, after the removal of the partition. Results are compared with those of gravity currents in simple rectangular tanks as well as with similar experiments in V-shaped valleys performed by Monaghan et al. (2009).

2 EXPERIMENTAL PROCEDURE - MEASUREMENTS

Experiments were conducted in a tank of rectangular upper cross section and a lower valley of trapezoidal shape. The dimensions of the tank are: width $W=23$ cm, height $H=25$ cm high and total length $L=5$ m. The trapezoidal section of the valley has the following dimensions: bottom width= 5 cm, height= 10 cm and side slope $1:1$. The depth a of the valley which measured vertically from the bed is 10 cm. The tank was separated into two reservoirs by a removable thick vertical partition, which was removed at the start of the experiments. One reservoir was filled with $H=4, 6, 8, 12, 14$ or 16 cm of well-mixed saltwater of density ρ_{sw} and the other with freshwater of density ρ_w ($\rho_w < \rho_{sw}$) until the free surface in both reservoirs was aligned. Twenty four experiments were performed twelve inside the trapezoidal section ($H=4, 6$ or 8 cm for four different densities) and twelve over the trapezoidal section ($H=12, 14$ or 16 cm for four different densities). The distance from the lock gate to the front edge of the current head is denoted as x (figure 1).

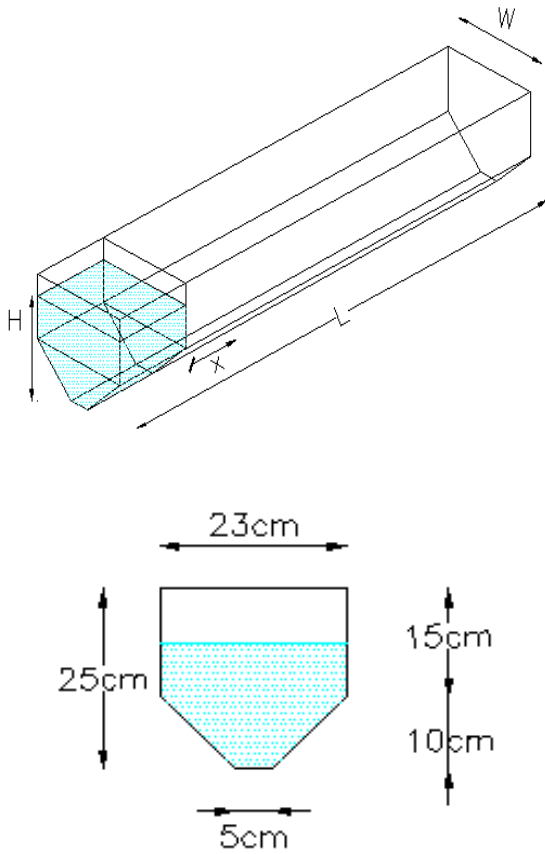

Figure 1: Tank dimensions and symbols used

The slope of the channel was horizontal. Experiments began with the removal of the vertical partition. Gravity current is generated, due to the horizontal density gradient, after the removal of the partition. The heavier fluid propagates towards the lighter fluid reservoir along the bottom of the tank and the lighter fluid propagates along the free surface in the opposite direction. For flow visualization, the saltwater was dyed with rhodamin (red color). Density difference between salt water and clear water was varied between 0.1 % and 0.4 % ($\rho_w=1000 \text{ kg/m}^3$, $\rho_{sw}=1010$ or 1020 or 1030 or 1040 kg/m^3). Series of images were captured using a camera mounted on a stationary tripod in front of the tank after the initiation of the current. These recordings were subsequently analysed to determine the front position and velocity as functions of time, by measuring the time required for the front to travel fixed-length intervals marked on the tank. A digital camera was used for the viewing of current and then measured the height and the position of the current front (figure 2).

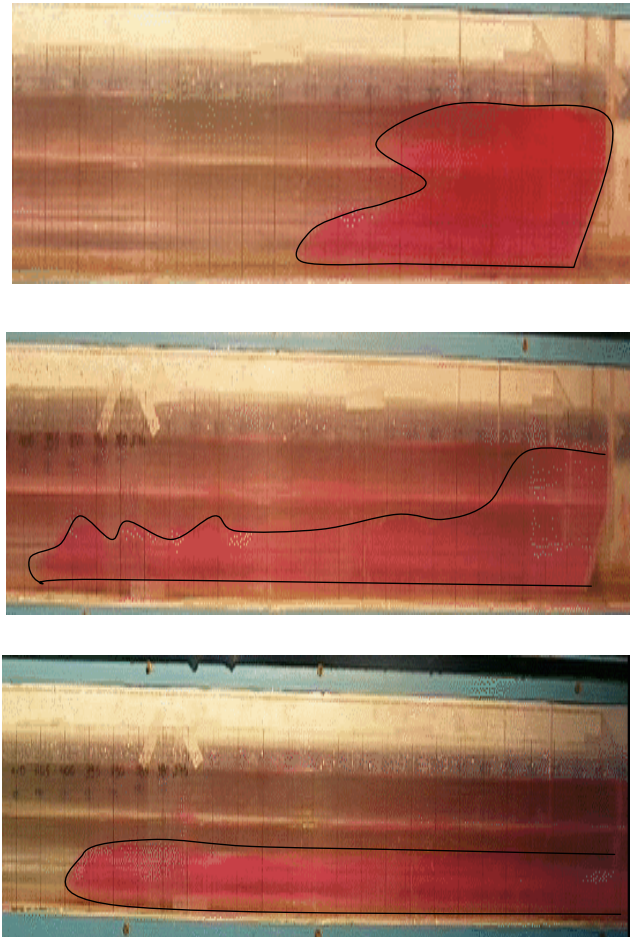

Figure 2: Gravity Current (H=14 cm, Density Difference 0.3%) at three locations (x=50 cm, x=120 cm, x=300 cm).

3 ANALYSIS OF RESULTS

In figure 3 the effect of density difference on the motion of the gravity current is examined. The current with the greater difference (density difference 0.4%) travels faster than the others in both cases (H=4 cm within valley and H= 16cm composite). This is due to the fact that the velocity of the gravity current increases with increasing density difference. The effect of density difference is more pronounced in the case of composite section than the trapezoidal section.

In figure 4 the effect of H on the motion of the gravity current is examined for the same density difference 0.1%. As it is observed, the gravity current with the greater H travels faster in all cases.

In figure 5 the dimensionless distance x^* is plotted against the dimensionless time t^* from the opening of the gate for currents within orthogonal and trapezoidal valleys. The distance x is made dimensionless with the water depth H ($x^* = x/H$) and the time t from the lock exchange with the

parameter $\sqrt{g(1-\gamma)/H}$ ($t^* = t\sqrt{g(1-\gamma)/H}$, $\gamma = \frac{\rho_w}{\rho_{sw}}$)

Also the time development of the gravity front from the experiments of Shin et al. (2004), for horizontal rectangular section, is included. It is shown that the motion of the current depends on the shape of the valley. The current moves faster within the trapezoidal section which is in agreement with the analytical findings of Monaghan et al (2009).

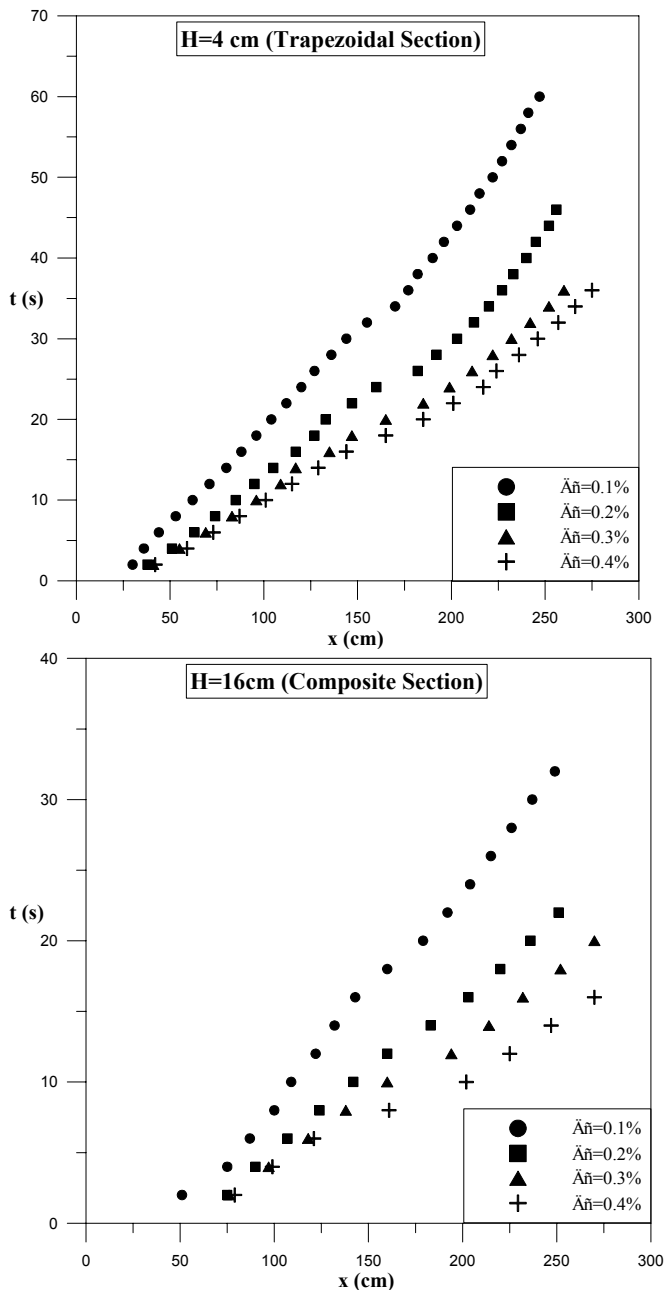

Figure 3: Effect of density difference on the motion of gravity current

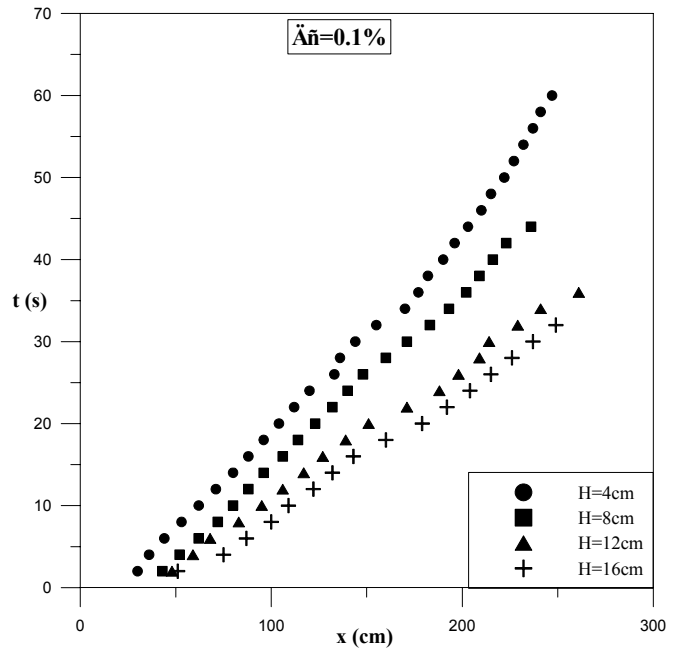

Figure 4: Effect of depth H on the motion of gravity current

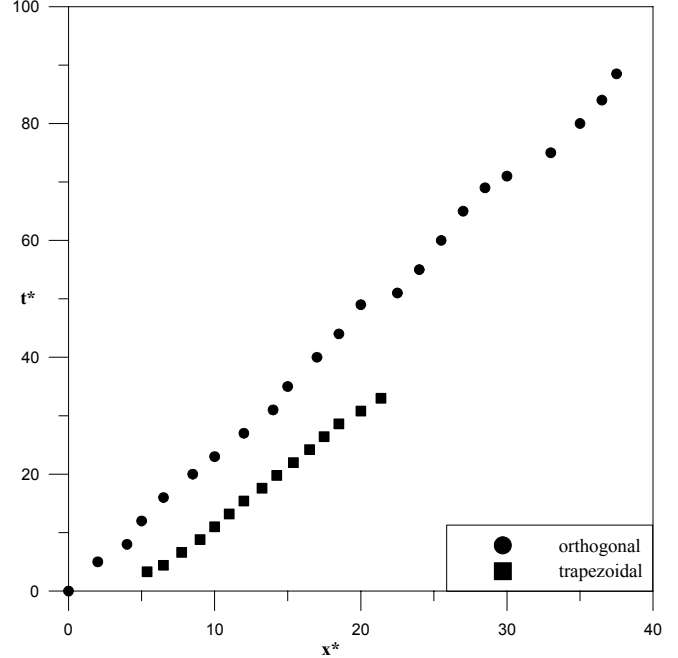

Figure 5: Time development of gravity front for orthogonal and trapezoidal sections (dimensionless)

Figure 6 includes box model results of Monaghan et al. (2009) for triangular valleys (slope of the valley is 12° , 23° and 41° to the horizontal with respective depths of the valley 0.03 m, 0.06 m and 0.12 m) together with our experimental results for trapezoidal valley (with side slope 1:1) and results for orthogonal valley (Shin et al., 2004). The effect of the valley geometry and the steepness of the flanks on the motion is significant.

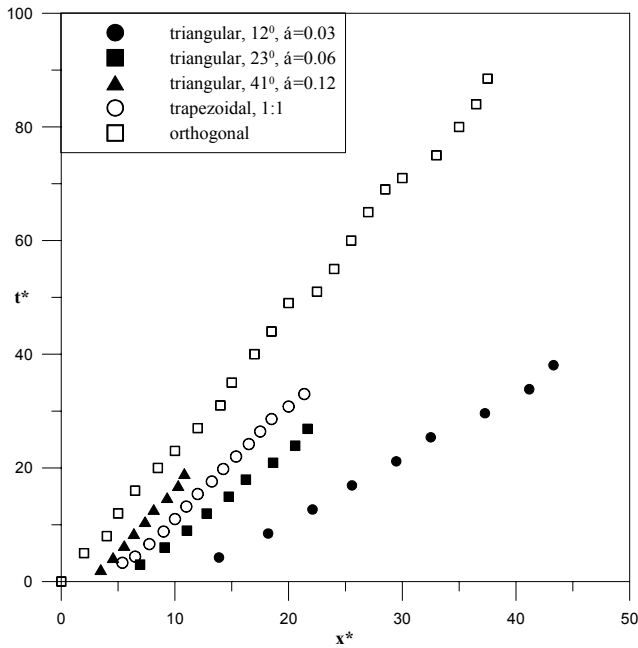

Figure 6: Dimensionless comparison between triangular, orthogonal and trapezoidal shape

In figure 7 the results of this study are compared with similar experiments performed by Monaghan et al. (2009). As it is shown in figure 7 the dimensionless distance y is plotted against the dimensionless time τ . The distance x is made dimensionless with the parameter l and the time t with the parameter σ . The former parameter l is defined as: $l = \left(\frac{2V}{aW} \right)$, $V =$ volume of the current

($V = L_1 W (H_0 + \frac{1}{2} a)$, $L_1 =$ distance between the lock gate and the rest of the tank, $W =$ current width, $H_0 =$ height of the water over the valley, $a =$ depth of the valley), and $\sigma = \frac{l}{Fr} \sqrt{\frac{2}{g'a}}$ where

$Fr =$ Froude number, $Fr = \frac{U}{\sqrt{g'h}}$ ($U =$ current speed, $h =$ height of the current and $g' = g(\rho_{sw} - \rho_w) / \rho_{sw}$ with $g = 9.81 \text{ m/s}^2$). As it is observed (figure 7) a satisfactory agreement exists between the measurements of these studies.

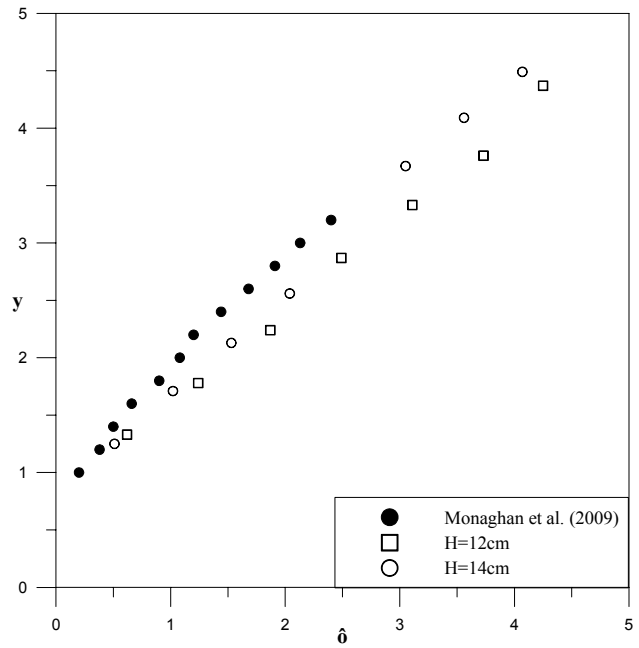

Figure 7: Time development of gravity front (dimensionless)

4 CONCLUSIONS

In this study the motion of saline gravity currents is investigated in lock-exchange experiments which were carried out in a tank of rectangular upper cross section and a lower valley of trapezoidal shape. The lock-exchange experiments are performed for equal depths of heavy and light fluid on both sides of the lock gate. The gate separates the two fluids (water and saltwater) with density difference 0.1%, 0.2%, 0.3 % and 0.4%. The main conclusions of this study are:

- The gravity current propagates with a parabolic head. The current with the greater difference density difference 0.4%) travels faster than the others in both cases ($H = 4 \text{ cm}$ and $H = 16 \text{ cm}$). This is due to the fact that the velocity of the gravity current increases with increasing density difference.
- The effect of density difference is more pronounced in the case of composite section than the trapezoidal section.
- The dimensionless distance x^* is plotted against the dimensionless time t^* for both orthogonal and trapezoidal valleys. The effect of the valley section on the motion of the current is clear. Also results from the box model of Monaghan et al. (2009) for triangular valleys of different side wall steepness indicate the dependence of the current motion on the geometry of the valley.

- The dimensionless distance y is plotted against the dimensionless time τ . There is a good agreement between the results of this study with similar experiments in V-shaped valleys performed by Monaghan et al. (2009).

REFERENCES

- Antenucci, J.P., Brooks, J.D., Hipsey, M.R. 2005. A simple model for quantifying cryptosporidium transport, dilution and potential risks in reservoirs, *J.Am Water Works Assoc.* 97, 86-93.
- Benjamin, T.B. 1968. Gravity currents and related phenomena, *J. Fluid Mech.*, 31, 209-248.
- Keevil, G.M., Peakall, J., Best, J., Amos, K.J. 2006. Flow structure in sinuous submarine channels : velocity and turbulence structure of an experimental channel. *Mar.Geol.* 229, 241-257.
- Marino, B.M., Thomas, L.P., 2009. Front condition for gravity currents in channels of nonrectangular symmetric cross-section shapes, *J. of Fluid Eng.*, Vol 131, 051201-1-6.
- Monaghan, J.J., Meriaux, C.A., Huppert, H.E., Mansour, J., 2009a. Particulate gravity currents along V-shaped valleys. *J.Fluid Mech.*, Vol 631, 419-440.
- Monaghan, J.J., Meriaux, C.A., Huppert, H.E., Monaghan J.M. 2009b. High Reynolds number gravity currents along V-shaped valleys. *European Journal of Mechanics B/Fluids*, (28), 651-659.
- Shin, J.O., Dalziel, S.B., and Linden, P.F. 2004. Gravity currents produced by lock-exchange, *J.Fluid Mech.*, 521, 1-34.
- Simpson, J.E. 1997. *Gravity Currents in the Environment and the Laboratory*, Cambridge Univ. Press, New York
- Takagi, D., Huppert, H.E., 2007. The effect of confining boundaries on viscous gravity currents. *J. Fluid Mech.*, Vol 577, 495-505.
- Takagi, D., Huppert, H.E., 2008. Viscous gravity currents inside confining channels and fractures. *Phys. Of Fluids* 20, 023104-1-6