

HENRY

Hydraulic Engineering Repository

Ein Service der Bundesanstalt für Wasserbau

Article, Published Version

Weichbrodt, Frank

Coastal Groynes in Germany

Die Küste

Zur Verfügung gestellt in Kooperation mit/Provided in Cooperation with:

Kuratorium für Forschung im Küsteningenieurwesen (KFKI)

Verfügbar unter/Available at: <https://hdl.handle.net/20.500.11970/101608>

Vorgeschlagene Zitierweise/Suggested citation:

Weichbrodt, Frank (2008): Coastal Groynes in Germany. In: Die Küste 74. Heide, Holstein: Boyens. S. 241-251.

Standardnutzungsbedingungen/Terms of Use:

Die Dokumente in HENRY stehen unter der Creative Commons Lizenz CC BY 4.0, sofern keine abweichenden Nutzungsbedingungen getroffen wurden. Damit ist sowohl die kommerzielle Nutzung als auch das Teilen, die Weiterbearbeitung und Speicherung erlaubt. Das Verwenden und das Bearbeiten stehen unter der Bedingung der Namensnennung. Im Einzelfall kann eine restriktivere Lizenz gelten; dann gelten abweichend von den obigen Nutzungsbedingungen die in der dort genannten Lizenz gewährten Nutzungsrechte.

Documents in HENRY are made available under the Creative Commons License CC BY 4.0, if no other license is applicable. Under CC BY 4.0 commercial use and sharing, remixing, transforming, and building upon the material of the work is permitted. In some cases a different, more restrictive license may apply; if applicable the terms of the restrictive license will be binding.



Coastal Groynes in Germany

By FRANK WEICHBRODT

Contents

1. Introduction	241
2. Review of History of Groyne Construction in Germany	243
3. Design of Groynes	247
4. Future Aspects	250
5. References	250

1. Introduction

Coastal groynes represent one of the oldest coastal protection structures in Germany. Since a wide beach is by far the best form of coastal protection at a sandy coast, the coastal engineer uses groynes for beach management or control. Today, coastal groynes are frequently used in combination with beach nourishment. Groynes are designed in such a way, that long-shore sediment transport is locally influenced in order to increase the persistence of sand at natural or artificially nourished beaches.

In the available literature, different definitions of groynes can be found. Generally, groynes are slender structures built to protect beaches, forelands, coast-parallel structures and other objects at the coast. They are arranged more or less normal to the coastline to influence near-shore currents and, thus, the sediment transport process in the littoral zone. Considering the function there is a differentiation between beach groynes influencing mainly



Fig. 1: Wooden single-row pile groynes at low water at the Baltic coast near Warnemünde (photo: WEICHBRODT, 2006)

wave caused currents and groynes located at islands and tidal inlets mainly acting at the tidal currents. The latter are named 'stream groynes' in German textbooks (EAK, 1993).

At the German Baltic Sea beach groynes still represent an important part of the coastal protection scheme. The groynes are mostly deployed in entire groyne systems (Fig. 1) to influence the movement of sediments along the shoreline as a result of wave-induced long-shore currents. Most of these groynes are built as permeable groynes consisting of wooden piles.

At the German North Sea coast, groynes are often installed as stream groynes, especially at islands and estuaries, to protect sandy coasts against erosion caused by tidal currents. These groynes are mostly constructed using rock and concrete because of usually heavy loads (Fig. 2).

Despite extensive national and international investigations having been carried out in the past including hydraulic/numerical model tests and field investigations, the effectiveness of coastal groynes is being controversially discussed in literature and by public authorities. However, many single groynes and groyne systems exist and have to be maintained at the German coast and new groynes are still built. Therefore, there is a need for a safe and efficient design.

Tab. 1 gives an review of the actual number of groynes at the coast of Germany broken down to the three federal coastal states with a coastline.



Fig. 2: Rock groyne at 'Hallig (holm) Südfall' (photo: HINRICHSSEN, 2005)

Table 1: Number of groynes in Germany

Federal state	Number of groynes
Lower Saxony	262 (North Sea)
Schleswig-Holstein	1245 (North Sea) 1143 (Baltic Sea)
Mecklenburg-Vorpommern	1129 (Baltic Sea)

In the following, some information on the history, the functional and constructive design and future aspects of groynes in Germany are given.

2. Review of History of Groyne Construction in Germany

Between 1815 and 1821, first simple groynes were built at the Island of Wangerooge in the North Sea for the purpose of protecting a lighthouse. The groynes were built of brushwood material without additional rubble protection. Due to information given by FÜLSCHER (1905), these first groynes were already seriously damaged in the winter of 1821/22. Nevertheless, more groynes of this simple design were built at Wangerooge in 1832 and 1834, but they had to be abandoned around 1850 because of destruction by currents and waves.

Starting 1843, further simple bush groynes were constructed on the Island of Norderney. Just like the first groynes built to protect the coastline of Wangerooge, these groynes were destroyed shortly after completion.

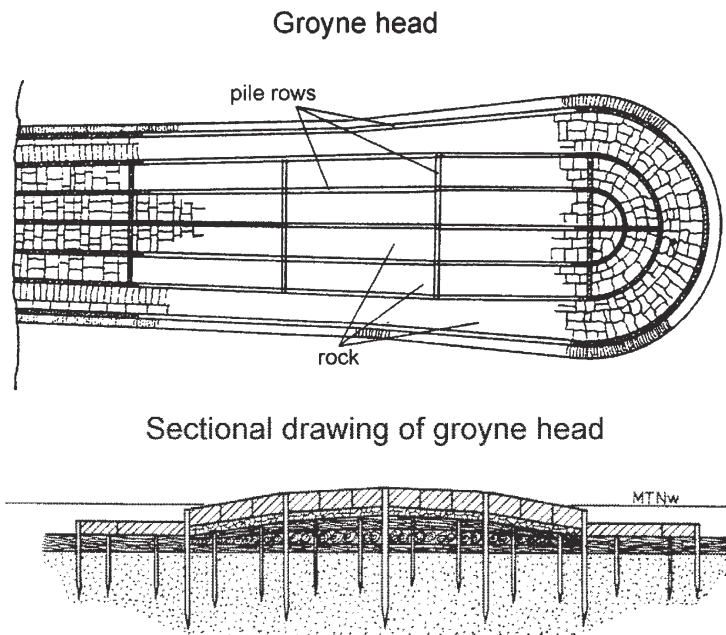

Fig. 3: First rock groynes on Norderney, 1861 (TRITT and ALTEMEIER, 1987; after FÜLSCHER, 1905)

Table 2: Year of first construction and type of groynes at the German North Sea islands

Island	Year of first groyne construction	Type of groyne
Borkum	1869	Rock groynes
Juist	1914	Pile groynes
Norderney	1843	Bush groynes
Baltrum	1873	Rock groynes
Langeoog	no groynes	–
Spiekeroog	1873	Rock groynes
Wangerooge	1815	Bush groynes
Amrum	1895	Rock groynes, Pile groynes
Föhr	1895	Pile groynes
Sylt	1872	Rock groynes, Pile groynes
Helgoland	1897	Fascines, fascine raft, Rock

Using this experience, coastal engineers began constructing various types of groynes from rubble or broken rock on the North Sea islands. The first seven solid groynes were installed at the western part of the Island of Norderney between 1860 and 1867. They were built with a length between 190 m and 215 m using layers of fascines, wooden piles and an cover of rock or rubble, as shown in Fig. 3. Only little damage was detected after this modification of groyne construction. Until 1877, five more of these groyne constructions were placed at the west side of Norderney.

Following the positive experience of groyne construction at Norderney, more groynes of this type were built on the other German islands in the North Sea, e.g. Borkum, Baltrum, Spiekeroog, Sylt and Wangerooge. Tab. 2 presents the year of construction and the type of groyne built along the North Sea island coasts. In Figs. 4 and 5, satellite views of the East and North Friesland islands are shown to illustrate the situation.

At some locations on the North Sea islands, wooden pile groynes were built as well. Since 1906, they were established on Borkum, Juist, Norderney, Sylt, Föhr and Amrum using various designs and were constructed both as permeable and as impermeable groynes. As a special construction, wooden pile boxes filled with rubble or concrete blocks (called box-type-groynes), were introduced for the first time in 1925.



Fig. 4: Satellite view of the East Friesland Islands (photo: Nasa World Wind – Wikipedia)



Fig. 5: Satellite view of the North Friesland Islands (photo: Nasa World Wind – Wikipedia)

Starting in the middle of the 1920s, different construction materials such as steel, concrete, reinforced concrete and asphalt were increasingly used for groyne construction. In the 1930s single wall groynes made of steel sheet piling were built. Later on, box-type-groynes made of two rows of sheet piling filled with sand, rubble or broken rock with or without a concrete armour layer became common along the coast. Combinations of various constructions methods and materials in one groyne were tested and very long submerged groynes were built.

However, wooden pile groynes became generally not too popular at the German North Sea islands although they seldom sustained any damage by currents and waves according to FÜLSCHER (1905). This may be also due to the fact that wooden constructions in sea water is susceptible to infestation by the shipworm (*teredo navalis*). Today, one will mostly find natural stone (e.g. basalt columns), concrete, steel and asphalt as construction material for groynes at the German North Sea coast.

Following recommendations of HAGEN (1863), the first groynes at the German Baltic coast were tentatively installed at the Island Ruden (near Usedom at the border to Poland) in 1843. Similar to those first ones at the North Sea coast, these groynes were very simple constructions consisting of two rows of piles entwined with pine branches. Compared to present groynes, they had small dimensions. With a length of 4 to 8 Ruthen (a Ruthe is an old dimension unit – 1 Ruthe = approx. 3.77 m), they were built in water depths of not more than 1.0 m. These groynes were destroyed by waves and scouring some years after completion. Over the years, advanced structural design and construction methods were introduced. Figs. 6 and 7 show some examples of groyne construction in the 19th century using fascines and rock armouring.

With the invention of pile drivers, the embedding length of piles in the ground could be remarkably increased. Thus, groynes were more stable and could better resist wave and ice forces. The length of groynes was increased and groynes were built up to a water depth of 3.0 m.

Pile groyne at Warnemünde 1895

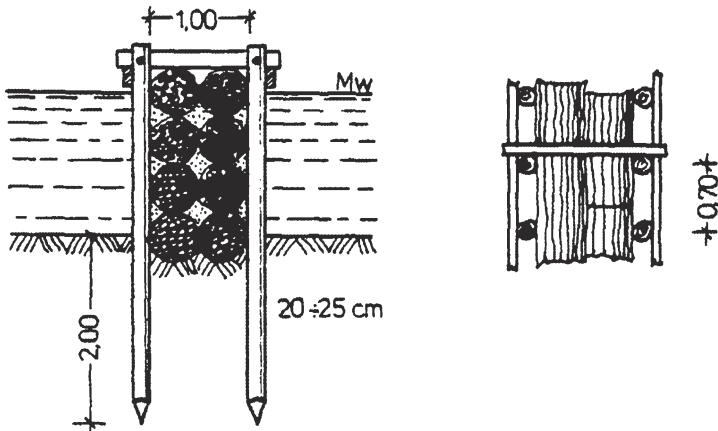

Fig. 6: Wooden groyne construction at the Baltic coast near Warnemünde, 1895 (TRITT and ALTEMEIER, 1987; after FÜLSCHER, 1905)

Before World War II, some groynes were built with steel sheet piling. However, substantial corrosion problems were encountered and groynes caused a risk for tourists at sandy beaches. Since they do not well merge into the environment as do the more naturally looking wooden stone or wooden groynes, they were not very popular and are not accepted today, in addition.

By comparing experience and practical knowledge from the construction of groynes, POPPE (1942) wrote: “among the simple groyne constructions, the wooden single-row pile

Pile groyne at Baltic Sea 1897

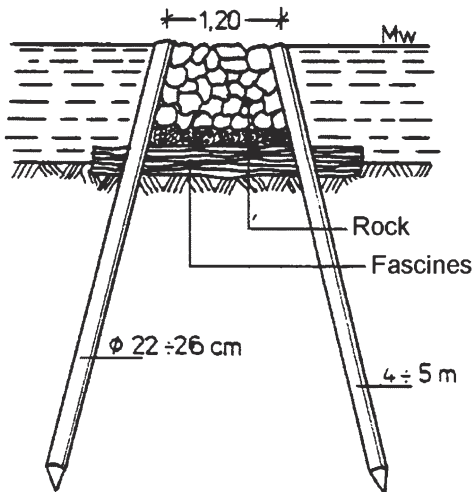

Fig. 7: Wooden groyne construction at the Baltic coast, 1897 (TRITT and ALTEMEIER, 1987; after FÜLSCHER, 1905)

groyne has proven best, despite some faults". At the Baltic coast of Germany and at the coast of Mecklenburg-Vorpommern in particular, the wooden single-row pile groyne became most accepted and has been the favoured design from World War II until now. Reasons are also the lower costs compared to double-row pile or stone groynes as well as the option to build the groyne with a varying permeability depending on its intended function.

In this contribution, it is not possible to describe the design details of all groynes which were established along the German coast during the last 200 years. Numerous examples from the history of groyne construction can be found in KRAMER and ROHDE (1992), the old literature cited above and others. A good overview of German publications on groyne construction, with a focus on the effectiveness of beach groynes, from the beginning until 1961 is given by PETERSEN (1961).

3. Design of Groynes

First papers on the experience with the functional and structural design of groynes were published by PLENER (1856), HAGEN (1863) and FRANZIUS (1884). Based on practical knowledge and field and model investigations, recommendations, design formulae or even manuals for the design of groynes were offered in the 'Shore Protection Manual' by CERC (1984), the 'Guide on the use of groynes in coastal engineering' by CIRIA (1990) and the 'Recommendations for Coastal Protection Structures' (EAK, 1993 and 2002). Further interesting publications are listed under references.

As mentioned before, many investigations were performed on the effectiveness of groynes at sandy beaches. Quite a few different recommendations for the length, the crest elevation, the inclination of the crest, the spacing between two neighbouring groynes in a system and the layout of a groyne can be found. Some detailed recommendations for the functional design of beach groynes in Germany are offered in EAK (1993).

Generally the crest elevation for North Sea groynes should be between 0.5 and 0.75 m above the planned beach level. The crest elevation should be >0.5 m above MThw (mean tidal high water) at the groyne root and 0.5 m above MTnw (mean tidal low water) at the head. Along the Baltic Sea coast, the crest elevation of wooden groynes is determined to be 0.5 m above mean water level. That ensures its functioning during events with elevated water levels. Groynes should be arranged normal to the coastline. The crest level is chosen to be horizontal or parallel to the beach slope.

With a focus on the Baltic coast, some diagrams can be used to determine groyne length, spacing within a system and its permeability. The groyne length can be determined as a function of local wave parameters (wave length) and beach slope. The spacing depends on its length, permeability and category of wave load at site.

Today, usually permeable single-row pile groynes with a permeability >20 % are used at the German Baltic coast for water depths > 1.0 m at the seaward part of the groyne. In a groyne system, the permeability is increased towards the end of the groyne field in order to avoid downdrift erosion effects at the beach.

The first concept for the functional design of a single groyne or a groyne system is often obtained by numerical model tests. Experience with existing groynes in the vicinity of the proposed construction site are included in the functional and structural design.

Another important issue of the engineering process is the structural design of a groyne. Papers published before 1945 present a lot of practical knowledge and information on damage sustained at existing groynes. Both, national and international investigations carried out

after 1945 are focused mainly on the functional design of beach groynes. Even though it may seem trivial to perform research on such a simple structure as a groyne, the lack of information for an economical structural design of groynes is evident. This may also be due to the lack of processes in the near-shore zone, which are complex and not yet fully understood.

Design methods used for breakwaters can be applied to groynes made of stone, rubble or concrete armour units. For steel or concrete sheet piling structures, design approaches for vertical walls are being used today. However, no special design methods for cost effective groyne constructions are available. Considering groynes at the German Baltic coast we find predominantly wooden single-row pile structures. They have a length between 50 and 90 m, where corresponding ramming depths of wooden piles are determined by an old empirical approach only based on water depth and experience. This approach uses a ratio of water depth to ramming depth of 1/3 to 2/3 for non-cohesive subsoil and 2/5 to 3/5 for cohesive subsoil respectively.

In 2001 the German Ministry for Research and Education (BMBF) approved and funded a research programme aiming at the development of a more scientific approach to design wooden groyne piles. The project focused on the load on piles induced by wave impact as well as vertical and horizontal ice forces. Holding forces depend on type of subsoil and dynamic effects. From existing publications, we could not find satisfactory information about wave induced pile movements and the possibility of ensuing liquefaction effects in the surrounding soil. Existing methods for the calculation of vertical loads and holding forces of piles gave differing results.

Therefore, the actual investigations, carried out between 2001 and 2005 were focused on wave induced pile movements, vertical ice forces and holding forces. This included possible

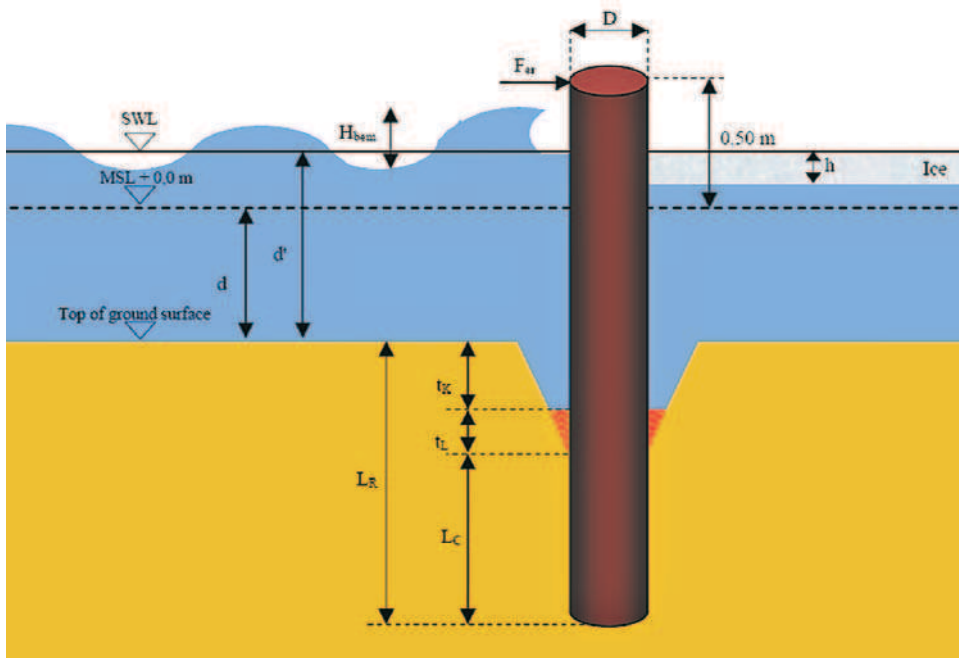

Fig. 8: Sketch for definition of parameters used in the recommendations (WEICHBRODT, 2008)

liquefaction effects of the surrounding soil. The research project was based on analysis of data from field measurements, experiments and laboratory tests (WEICHBRODT et al., 2004, 2006).

Based on results from this project and accepted methods, recommendations for the dimensioning of the ramming depth of groyne piles as a function of local wave loads, ice loads, water depth, pile diameter and type of subsoil were developed. In this publication, it is not possible to describe all recommendations in detail. Reference is made to the literature mentioned before and the dissertation of the author. An outline of the dimensioning procedure will be given in the following. Fig. 8 shows the definitions for the following explanations.

The investigations show that possible scouring effects around the piles due to waves and currents have to be considered. Safety supplements to pile length for scour and changes of the bottom surface are defined with $t_{KN} = 1.5$ m for a non-cohesive upper soil layer and with $t_{KB} = 0.25$ m for a cohesive upper soil layer. For periods with a closed ice cover, loads by waves and currents are reduced. Thus, for the calculation of the necessary ramming depths with respect to ice forces, reduced values for t_{KN} and t_{KB} are recommended.

Based on the investigations of pore water pressure and liquefaction effects, a second safety supplement for liquefaction is recommended for practical applications. This supplement is defined as $t_L = 0.50$ m at sites with non-cohesive upper soil layers. Organic soil layers and soil layers with thicknesses smaller than 0.2 m should not be considered for the calculation of holding forces.

All horizontal loads, vertical loads and holding forces are compiled in tables as a function of water depth or clamping depth L_C for practical use (see Fig. 8 for differentiation between clamping depth L_C and ramming/embedding length L_R). The horizontal wave loads were calculated based on the approach of MORISON et al. (1950) and the respective recommendations of the EAK (2002).

The calculated wave induced moment at the pile (related to the sea bottom) is converted into a concentrated load at the top of the pile, which is given in a table for various water depths. Depending on the safety supplements and the type of subsoil, the planning engineer can calculate a moment at the theoretical centre of rotation of the pile. This moment has to be compared with the resisting moment of the holding forces, which is given in a table depending on the clamping depth L_C . Thus, the required clamping depth for the pile to counteract horizontal loads is found. The flexural strength of the pile itself, depending on pile dimensions and material properties, must be checked to determine the necessary pile diameter.

The design ice thickness h , which is necessary for determining horizontal and vertical ice loads was found by using a statistic analysis of ice data at the German Baltic coast. Values range between 0.25 m and 0.40 m depending on the location at the coast. Horizontal ice loads were calculated according to accepted methods by HIRAYAMA et al. (1974). Based on the performed laboratory investigations, recommendations focused on using Russian Standards to calculate the vertical ice loads on groyne piles. Respective tables for practical applications were established. By comparing the ice loads to the vertical holding forces, the clamping depth of the pile can be calculated easily. The tensile strength of the pile is given in a table, too.

The necessary ramming depth L_R of the pile can be calculated from the clamping depth L_C and the safety supplements defined before. The results allow the determination of the ramming depth of wooden piles in shallow water as a function of wave loads, wave induced pile movements, possible resulting liquefaction effects, ice loads, water depth and various subsoil conditions.

4. Future Aspects

Groynes can be found at the North and Baltic Sea coast in significant numbers and will continue to be important elements of coastal protection schemes in Germany. Even though the efficiency and value of beach groynes is controversially discussed, groynes have been used to increase the retention period of sand at eroding shorelines. In particular, beach groynes are being used and will be used in future in combination with beach nourishment. Until now, no generally accepted tool exist to predict long-term morphological changes near groynes or groyne systems in detail. There are still various questions considering both hydraulic and numerical modeling.

Cost-benefit analysis will must be an important aspect in planning and design in future. With a view at the defined value of a coastal region (habitation, industry, natural resources, effect on neighbouring areas etc.) the question about coastal protection or not is easily answered. For that, the efficiency and sustainability of the various available coastal protection methods and structures must be compared (e.g. groynes versus beach nourishment or a combination of the two). Interesting cogitations and investigations about this topic can be found already in very old publications and historic documents found at archives or coastal authorities.

A scientific method for the structural design of groyne piles is available for wooden single-row pile groynes. However, additional research is recommended e.g. to study the effect of pore water pressure on the stability of oscillating piles or other structures in the near-shore zone.

Because of the danger of infestation of wooden constructions with the shipworm (*teredo navalis*) in the North Sea as well as in the western part of the Baltic Sea, only lumber which is resistant against *teredo navalis* should be used. However, to avoid the use of tropical hard wood, an interesting new development to protect wooden constructions with geotextiles is introduced (KOHLHASE, DEDE, 2006). This method might be a possibility for other wooden constructions in coastal engineering practice.

5. References

- COASTAL ENGINEERING RESEARCH CENTER: Shore Protection Manual, Department of the Army, US Army Corps of Engineers, Washington DC, 1984.
- CONSTRUCTION INDUSTRY RESEARCH AND INFORMATION ASSOCIATION (CIRIA): Guide on the Uses of Groynes in Coastal Engineering, edited by Fleming, C.A., Report 119, London.
- EAK 1993: Empfehlungen für die Ausführung von Küstenschutzwerken, Editor: Kuratorium für Forschung im Küsteningenieurwesen, Heide i. Holstein, 2002.
- EAK 2002: Empfehlungen für die Ausführung von Küstenschutzwerken, Editor: Kuratorium für Forschung im Küsteningenieurwesen, Heide i. Holstein, 2002.
- FÜLSCHER: Über Schutzbauten zur Erhaltung der Ost- und Nordfriesischen Inseln, Ernst und Sohn, Berlin, 1905.
- FRANZIUS, L.: Wasserbau am Meere und in Strommündungen, Handbuch der Ingenieurwissenschaften, III. Band, Franzius, L. & Sonne, E., Hannover, 1884.
- GOVERNMENT DEPARTMENT OF RUSSIA: Loads and Effects by Waves, Ice and Ships on Hydro-Engineering Constructions. Moscow, 1995.
- GUTSCHE, H.: Über den Einfluss von Strandbuhnen auf die Sandwanderung an Flachküsten, Mitteilungen des Franzius-Instituts für Grund- und Wasserbau, Hannover, 1961.
- HAGEN, G.: Handbuch der Wasserbaukunst, Theil III, Band 2, Verlag von Ernst & Korn, 1863.
- HIRAYAMA, K.; SCHWARZ, J. and WU, H. C.: An Investigation of Ice Forces on Vertical Structures, Iowa Institute of Hydraulic Research, Cold Regions Research and Engineering Laboratory, Hanover, NH, 1974.

- KOHLHASE, S.: Bühnen zum Schutz von Erosionsküsten, *Traditio et Innovatio*, 6. Jahrgang, Heft 2, Forschungsmagazin der Universität Rostock, Hinstorff Verlag, Rostock, 2001.
- KOHLHASE, S. u. DEDE, C.: Engineering Approach to Protect Wooden Constructions Against Attack of *Teredo navalis* : Considerations and Results of a Field Experiment in the Baltic Sea. In: OU, SHAN-HWEI; KAO, CHIA CHUEN and HSU, TAI-WEN: *Proceedings of Third Chinese-German Joint Symposium on Coastal and Ocean Engineering*, Tainan, Taiwan published by Coastal Ocean Monitoring Center, National Cheng Kung University, Tainan, 2006.
- KRAMER, J. u. ROHDE, H.: *Historischer Küstenschutz – Deichbau, Inselschutz und Binnenentwässerung an Nord- und Ostsee*, Deutscher Verband für Wasserwirtschaft und Kulturbau, Wittwer Conrad Verlag, Stuttgart, 1992.
- MORISON, J.; O'BRIEN, M.; JOHNSON, J. and SCHAAF, S.: *The Force Exerted by Surface Waves on Piles*, *Petroleum Transactions* Vol. 189, AIME, 1950.
- PETERSEN, M.: Das deutsche Schrifttum über Seebühnen an sandigen Küsten, *Die Küste* H. 9, 1961.
- PLENER: *Bemerkungen über die ostfriesischen Inseln in geognostischer und hydrotechnischer Beziehung*. Hannov. Z. Arch. u. Ing. Ver., 1856.
- POPPE, F.: *Uferschutzarbeiten an der Ostseeküste vom Darß bis Hiddensee*, *Die Bautechnik* 20. Jahrgang Heft 54/56, Berlin, 1942.
- TRITT, W. P. u. ALTEMEIER, G.: *Bühnen im Küstenschutz*, Franzius-Institut für Wasserbau und Küsteningenieurwesen der Universität Hannover, Sonderübung, 1987.
- WEICHBRODT, F.; DEDE, C.; RADOMSKI, J. and KOHLHASE, S.: Dimensioning of Ramming Depth of Groyne Piles. In: OU, SHAN-HWEI; KAO, CHIA CHUEN and HSU, TAI-WEN (Hrsg.): *Proceedings of Third Chinese-German Joint Symposium on Coastal and Ocean Engineering*, Tainan, Taiwan, published by Coastal Ocean Monitoring Center, National Cheng Kung University, 2006.
- WEICHBRODT, F.; DEDE, C.; RADOMSKI, J. and KOHLHASE, S.: Investigation of Input Data for the Dimensioning of Groyne Piles. In: *29th International Conference on Coastal Engineering*, Lissabon, Portugal, 2004.
- WEICHBRODT, F.: *Development of a Procedure for Structural Design of Wooden Groynes in Coastal Engineering*, Dissertation, Rostock, 2008.
- WEISS, D.: *Einreihige Holzpahlbühnen im technischen Küstenschutz von Mecklenburg-Vorpommern*, *Die Küste*, H. 52, 1991.