

# A Compact Rectenna Design with Wide Input Power Range for Wireless Power Transfer

Ping Lu, *Member, IEEE*, Chaoyun Song, *Member, IEEE* and Ka Ma Huang, *Senior Member, IEEE*

**Abstract**—A compact rectenna with a wide input power range is proposed for wireless power transfer (WPT). Two different diodes, having distinct operating powers, i.e. high-input-power diode and low-input-power diode, are introduced to the rectenna design for extending the operating input power range. A mid-inductor is placed in the rectifying circuit to isolate the radio frequency (RF) signal from DC power, thereby delivering the rectified DC power to the load. Also, with the aid of mid-inductor, the fundamental RF signal and harmonic signals could flow back to the two rectifying diodes for achieving higher conversion efficiency via the means of harmonic signal re-rectification. Owing to the mid-inductor, the sub-rectifier circuit can be avoided, and a compact structure can therefore be realized. Over 50% measured conversion efficiency  $\eta_c$  can be achieved in a very wide input power range of 35 dB (-10 to 25 dBm). The proposed rectenna can be widely used in WPT systems with unpredictable and variable RF energy levels.

**Keywords**—Compact rectenna; harmonic recycling, wide input power range; wireless power transfer.

## I. INTRODUCTION

With the rapid development of wireless communication technology, trillions of radio transmitters, such as the mobile base stations and radio frequency (RF) signal towers, have sprung up all over the world. As a consequence, considerable radio frequency (RF) energy is emitted into space, which becomes a stable source for energy harvesting. Using such “wireless power” to charge portable and low-power electronic devices will be a feasible and promising solution for future green communications. The rectenna, which collects the wireless energy from the ambient environment and then converts the captured RF power into DC power, is a key component in the WPT and/or energy harvesting system to power electronic devices [1]-[2]. However, in practice, the power density could vary significantly in different locations and environments. Therefore, the received RF power is typically dynamic and unpredictable for most mobile devices. Unfortunately, the conventional rectennas can only achieve high RF-to-dc conversion efficiency for a narrow input power range due to the limitations in diodes and circuitry topologies.

To solve such problems, significant efforts have been paid to

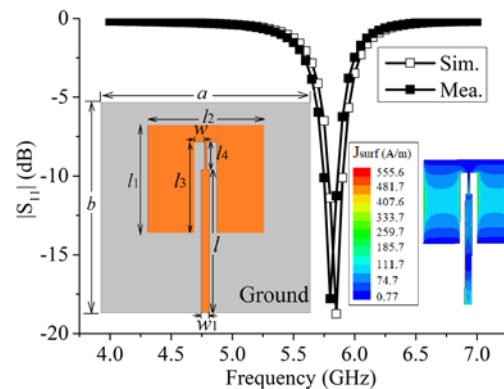

Fig. 1.  $S$  parameter of the proposed receiving rectenna. ( $l_1=12.8$  mm,  $l_2=13.9$  mm,  $l_3=10.8$  mm,  $l_4=3.3$  mm,  $l=17$  mm,  $w_1=1$  mm,  $w=1.2$  mm,  $a=25$  mm,  $b=20$  mm.)

extend the input power range of the rectenna. In recent years, many approaches have been reported to realize high RF-to-dc conversion efficiency within a wider input power range [3]-[6]. Some rectifiers using transmission line-based resistance compression networks (TLRCN) was implemented to create a resistance-compressed rectifying circuit over a 10 dB power range [3]. To enhance the conversion efficiency, a rectifier with reflected power recycling is proposed based on a branch-line coupler. However, these coupler- and TLRCN-based rectifiers normally need several auxiliary rectifiers and circuit branches, therefore more microstrip lines and circuit components are needed, which subsequently increases the rectifier size, cost, loss and complexity [3]-[4].

Some reconfigurable rectifiers with active RF switches were reported for a wide input power [5]-[9]. In [5]-[6], by using an integrated single-pole 4-throw (SP4T) RF switch or single-pole double-throw (SPDT) switch, the reconfigurable rectifying circuit can automatically choose the most favorable matching circuit/rectifier topology depending on the incident power level. Due to the active switch and power sensing chips, additional bias network and switch loss will be introduced, resulting in a higher complexity, higher loss and more difficulties in integration. To avoid the bias network, some adaptive rectifiers with a depletion-mode field-effect transistor (FET) or metal-oxide-semiconductor FET (MOSFET) switch were proposed to extend the operation input power range [7]-[9]. But the use of FET and MOSFET could still consume a considerable amount of power and therefore reducing the overall conversion efficiency. Besides, these active switches can suffer from the problems of linearity and thermal effects, especially at high frequencies ( $> 3$ GHz) [7]-[9].

Recently, a novel cooperative rectifying circuit was proposed

Manuscript received Nov. 5, 2019. The work is supported by National Natural Science Foundation of China (No. 51907130 and No. 61931009), and the Postdoctoral Science Foundation of China (No.0020504153007). (Corresponding authors: Ping Lu)

P. Lu and K. M. Huang are with the Key Laboratory of Wireless Power Transmission Ministry of Education and School of Electronics and Information Engineering, Sichuan University, Chengdu 610064, China. (e-mail: [pinglu90@scu.edu.cn](mailto:pinglu90@scu.edu.cn); [kmhuang@scu.edu.cn](mailto:kmhuang@scu.edu.cn))

C. Song is with the Department of Electrical Engineering and Electronics, University of Liverpool, Liverpool L69 3GJ, U.K, and he is also with the School of Engineering and Physical Sciences, Heriot-Watt University, Edinburgh EH14 4AS, Scotland, UK (e-mail: [chaoyunsong@gmail.com](mailto:chaoyunsong@gmail.com))

to exhibit high conversion efficiency over a wide input power range. Two different diodes, which are optimized for high conversion efficiency over their respective operation power regions, have been used to rectify the RF power cooperatively for extending the input power range. However, an extra sub-rectifier and auxiliary circuit were still needed [10]. Therefore, a compact rectenna design who maintains high conversion efficiency in a wide power range is highly demanded, but it is undoubtedly a challenging research task.

In this letter, a compact rectenna using two different rectifying diodes is proposed for WPT with dynamic input power densities (to deal with the uncertainty in space). The diodes are installed in the main branch and sub-branch of rectifying circuit, respectively. In this structure, the rectifier diode installed on the sub-branch can be combined to the main rectifying circuit, thereby avoiding the need for extra sub-rectifiers. Owing to the addition of a mid-inductor, the RF power including high-order harmonics can flow through the two rectifier diodes, and then converted into DC power for improving the overall conversion efficiency. The proposed rectenna has advantages in terms of compactness, simplicity and low-cost for integration in practical applications.

## II. COMPACT RECTENNA WITH WIDE INPUT POWER RANGE

The proposed rectenna is comprised of a compact receiving antenna and a wide-input-power rectifying circuit. It is printed on a single layer of Printed Circuit Board (PCB) using Rogers 4003C substrate ( $\epsilon_r=3.48$ ) with a thickness of  $h=0.813$  mm. The receiving antenna and the rectifying circuit are electrically connected by using a quarter-wavelength microstrip line.

### A. Miniaturized Receiving Antenna

The proposed antenna is fabricated on a grounded Rogers 4003C substrate with a size of  $a \times b$  as depicted in Fig. 1, where the receiving antenna contains a rectangular patch with a size of  $l_1 \times l_2$  ( $12.8 \times 13.9$  mm<sup>2</sup>) and an electrical size of  $0.25\lambda_0 \times 0.26\lambda_0$  at 5.8 GHz, where  $\lambda_0$  is the wavelength in free space. Two slots with a size of  $l_3 \times w$  are etched in the middle of the patch to accommodate an inserted feed line, therefore the electrical length of the current flow is extended (over the “n” shaped patch) to reduce the resonant frequency for compactness, as depicted in the antenna current distribution in Fig. 1. Thanks to the slots, the proposed antenna has realized a size miniaturization of 57%, compared to the conventional half-

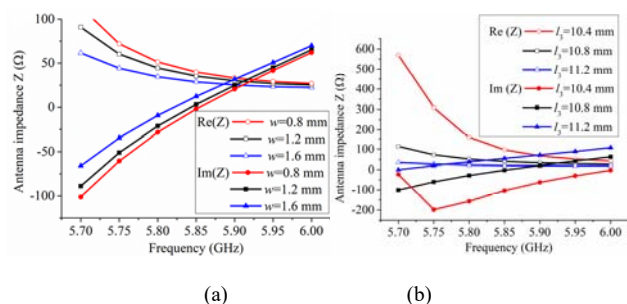

Fig. 2. Parametric study of the antenna impedance by using different sizes for the feed slot. (a) The impact of slot width. (b) The impact of slot length.

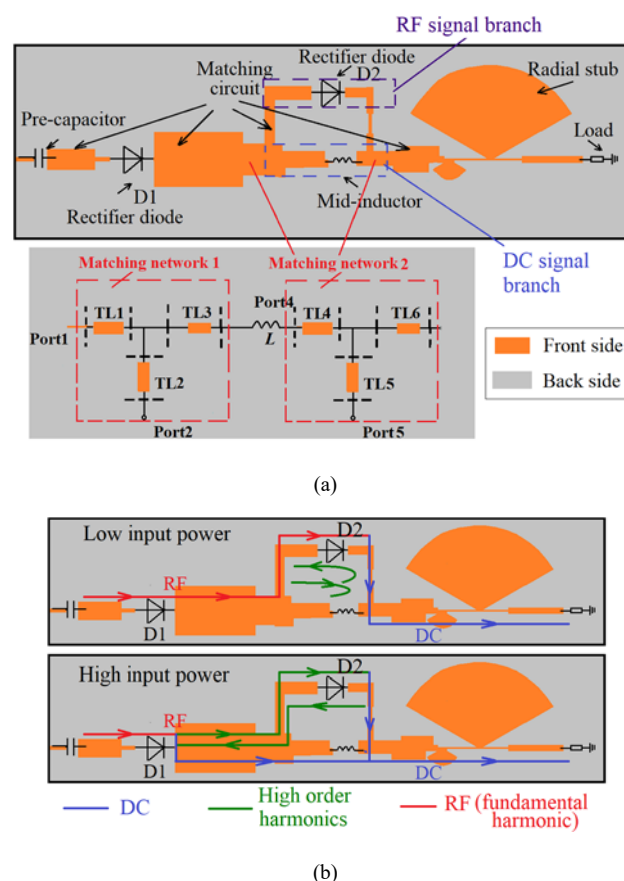

Fig. 3. Proposed rectifying circuit with two matching networks. (a) Rectifying circuit structure with detailed illustration of matching networks. (b) Input RF signal, harmonic signal and DC signal paths of the proposed rectifier at low and high input power levels.

wavelength rectangular patch without slots. Besides, the whole antenna dimension is optimally designed to manipulate the trade-off between the antenna size and efficiency (gain). The proposed antenna is fed by using a two-section matching microstrip line, and the size of the feeding line and slots can be determined (using theoretical calculation and software optimization) for good impedance matching at 5.8 GHz. The proposed antenna is simulated by using the HFSS software. The impedances of the patch with different slot sizes are investigated, as displayed in Fig. 2, where the antenna impedance changes with the size of the slots. It can be seen that the length of slot ( $l_3$ ) could affect the antenna impedance greatly (see Fig. 2(b)), but the small variations of the slot width ( $w$ ) have a little impact on the antenna performance (see Fig. 2(a)). When the length of slots increases, the real part of the antenna impedance decreases, but the imaginary part of which is increased. By adjusting the sizes of slots and feeding line, the proposed antenna can be tuned for good impedance matching performance. The simulated and measured reflection coefficients ( $|S_{11}|$ ) of the proposed antenna are depicted in Fig. 1, where the simulated (measured)  $|S_{11}|=-17.8$  dB @5.8GHz ( $|S_{11}|=-16.2$  dB @5.75 GHz and  $|S_{11}|=-11.4$  dB@5.8 GHz). Besides, the simulated (measured) maximum gain and antenna efficiency are 5.97 dBi (5.95 dBi) and 96.4% (95%).

### B. Rectifying Circuit Structure with Wide Input Power Range

The compact rectifying circuit is designed for a wide input power range, as displayed in Fig. 3 (a), where the circuit is printed on the same Rogers 4003C substrate. The proposed rectifying circuit contains a pre-capacitor, two rectifier diodes (D1 and D2), a mid-inductor, radial stubs, matching circuits and a load. A 100-pF pre-capacitor is used as an input filter. It not only protects the receiving antenna from the reverse current but also suppresses the high-order harmonics in collaboration with the output filter (radial stubs). A 22-nH mid-inductor is inserted into the main branch of the rectifying circuit to isolate the RF power from DC power. Several radial stubs (equivalent to the by-pass capacitor) are used as the output filter to smooth the output DC voltage ripples. Some microstrip lines are placed between the pre-capacitor, rectifier diodes, radial stubs and the load to achieve good impedance matching between the receiving antenna and the rectifying circuit.

It is well known that each diode has unique threshold voltages ( $V_r$ ) and breakdown voltages ( $V_b$ ), therefore the rectifying diode can work well within a very well-defined operating area, in which the incident RF voltage amplitude is higher than the threshold voltage and lower than the breakdown voltage of diodes. When the incident RF power is lower than the minimal start-up power of the diode, most input power will be consumed by the diode itself, thus the rectifier diode basically does not work. As the input power level increases, that is, the input power is higher than the start-up power of diodes (i.e., the voltage on the diode is higher than the diode threshold voltage), the nonlinear junction resistance ( $R_j$ ) of the diode gradually becomes the dominant component, and the RF power can therefore be rectified by the rectifying diode. Hence, two rectifier diodes (D1 and D2) which own different threshold voltages and breakdown voltages are implemented in the rectifying circuit for cooperatively operating in their respective optimal power regions to extend the input power range of the rectenna. The high-input power rectifier diode (D1) with high forward bias voltage is printed on the main branch of the circuit, between the pre-capacitor and the mid-inductor. Another rectifying diode (D2) with a smaller forwards voltage who operates well at low input powers, is installed on the sub-branch in parallel to the mid-inductor. The high-input-power diode (D1) is mounted in front of the low-input-power one (D2). In this design, the Schottky diodes HSMS 2860 and HSMS 2850 with  $V_r=0.65V$  (2860) and  $0.35V$  (2850),  $V_b=7V$  (2860) and  $3.8V$  (2850) are respectively selected as D1 and D2 for the cooperative combination of high power (0 to 25 dBm) and low power (-10

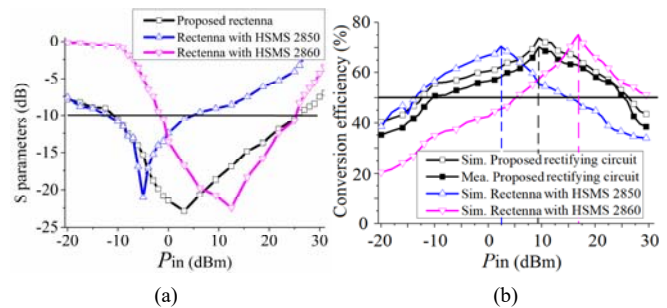

Fig. 5. Performance of the proposed rectenna. (a) S parameters. (b) Conversion efficiency.

to 0 dBm) operating region for the proposed rectifying circuit [11]. The two rectifier diodes (D1 and D2) can be placed either in series or in parallel. In this design, the series connection scheme is chosen to avoid the need of shorting vias.

### C. Principle of Proposed Rectifying Circuit

The proposed rectifying circuit can be automatically and passively (no active switch is needed) reconfigured to use the desired rectification components for low and high input powers.

When the input power is low, i.e. the voltage on the diode is lower than  $V_{r,HSMS2860}=0.65V$  and higher than  $V_{r,HSMS2850}=0.35V$ , the diode D1 is unable to be functionalized (turned-on), but the diode D2 gets to work. Due to the mid-inductor, no RF power can be delivered to the load directly, but the RF power mainly flows through D2 for the rectification. Then, the rectified DC power can be delivered to the load. Also, the mid-inductor can be used as RF choke, which lets the high-order harmonic signals travel back to D2 and convert the harmonic power to DC power for higher conversion efficiency. This is similar to the concept of harmonic recycling scheme [12] but with significant modifications to serve the proposed dual diode passive switching system. As the input power increases, i.e. the voltage on the diode is higher than  $V_{r,HSMS2860}=0.65V$ , D1 plays the dominant role, nevertheless, both rectifying diodes can work well. The input power can be rectified by using D1, and the RF power is converted to the DC power with high-order harmonics. Then, the rectified DC power can flow through the mid-inductor, and output to the load immediately, while the high-order harmonics, whose power is much lower than the fundamental one, is guided to D2 for re-rectification, as displayed in Fig. 3(b).

Due to the mid-inductor, the injected RF signal can be isolated from the DC components, while the RF power including the high-order harmonic powers can be successfully fed into D2 on the sub-branch for improving the conversion efficiency. Besides, with the mid-inductor, the sub-rectifying circuit can be combined to the main rectifying circuit for miniaturization.

### D. Matching Circuit Design

Two three-port matching networks are designed and optimized (using ADS software) to enable the efficient delivery of RF powers from the sub-branch to the load, as displayed in Fig. 3 (a), where in the first matching network, port 1 is connected to diode D1, and port 2 and port 3 are connected to the sub-rectifier and mid-inductor ( $L$ ). While in the second matching network, port 4 is connected to the mid-inductor, and

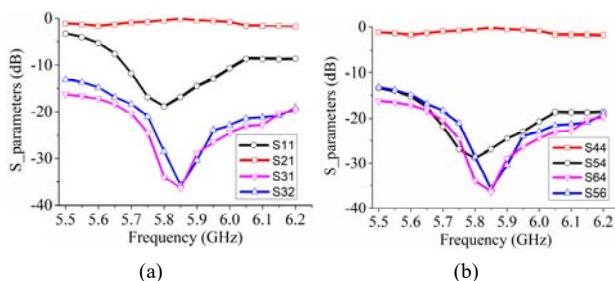

Fig. 4. S parameters of two matching network. (a) Matching network 1 at -5 dBm. (b) Matching network 2 at 15 dBm.



port 5 and port 6 are connected to the sub-rectifier and the radial stubs respectively. As depicted in Fig. 3(a), two individual matching networks are constructed using six transmission lines  $TL_i$ , ( $i=1-6$ ) between the rectifier and the radial stubs.

The design guideline of these matching components is briefly summarized below:

- 1) At high input power (the rectification of D1 is dominated), most RF power is converted to DC power, and the “matching network 1” plays a less important role in transmitting RF power to rectifier D2. Hence, the parameters of the “matching network 2” can be found to achieve good matching to the impedance of the radial stubs with load resistor at high input power for ensuring effective DC power delivery to the load.
- 2) As the input power decreases, the effect of “matching network 1” becomes significant. Then, the parameters for the “matching network 1” and the inductance of the mid-inductor can be obtained to achieve good matching at low input power to let RF power flow through the diode D2. Meanwhile, the function of the “matching network 2”, i.e. DC power delivery to load, should be maintained.
- 3) Finally, fine-tune the two matching circuits and mid-inductor value to yield good impedance matching and obtain more output DC power on the load. It is worth noting that the inductance of the mid-inductor will need to be carefully optimized since it could affect the overall matching between two networks.

By adjusting the size of these transmission lines and choosing an appropriate mid-inductor by using the load-pull simulation in the Keysight ADS simulation software, the desired frequency responses of the matching network can be found, and the proposed matching network can effectively guide the RF power (including high-order harmonics) injected at port 1 to the sub-branch, and then transmitted to the load. The frequency dependences of S-parameter of the proposed matching network are also simulated using different input power levels, as displayed in Fig. 4. It can be seen that at 5.8 GHz, the transmission coefficient ( $S_{21}$ ) from port 1 to port 2 is around 0 dB (for “matching network 1”), while the reflection coefficient ( $S_{11}$ ) at Port 1 is lower than 10 dB, indicating that the RF power injected at Port 1 can be efficiently transmitted to port 2 and flow through the rectifier using diode D2. Besides, the transmission coefficients of  $S_{31}$  and  $S_{32}$  is smaller than -25 dB, which shows that the RF power is isolated from dc power. Thus only the dc power can be injected to the mid-inductor. In addition, the transmission coefficients between Port 4, Port 5 and Port 6 ( $S_{64}$ ,  $S_{54}$  and  $S_{56}$ ) are smaller than -25 dB for “matching network 2”, while its reflection coefficient at Port 4 is around 0 dB, signifying that no RF components (but dc power) can be transmitted from Port 4 and Port 5 to the load (at Port 6).

Besides, owing to the matching network, the entire rectifying circuit could achieve good impedance matching, which can be verified from the S parameter results ( $|S_{11}|$ ) of the proposed circuit as depicted in Fig. 5(a). The simulated  $S_{11}$  of the proposed rectenna varies between -10.56 and -22.92 dB under the input power of -10~25 dBm at 5.8 GHz, which demonstrates the excellent impedance matching over a wide power range. In addition, the rectennas using a single high-input-power diode

(HSMS 2860) and using a single low-input-power diode (HSMS 2850) are simulated separately, as given in Fig. 5 (a). More specifically, the rectenna using a single HSMS 2860 can achieve good matching ( $S_{11} < -10$  dB) within the input power range of -1 to 25 dBm. In comparison, the rectenna with a single HSMS 2850 can reach similar matching performance over the input power range of -10 to 3 dBm. Due to effective combination of the two different diodes, the overall input power range of the proposed rectenna can therefore be extended significantly.

### III. PERFORMANCE OF PROPOSED RECTENNA

A picture of the fabricated rectenna using the Rogers 4003C substrate is given in Fig. 6, where the proposed receiving antenna is connected to the rectifying circuit with a quarter wavelength transmission line at the frequency of interest (5.8 GHz).

The RF-to-dc conversion efficiency ( $\eta_c$ ) of the rectifying circuit can be written as

$$\eta_c = \frac{V_{dc}^2}{P_{in} R_L} \quad (1)$$

And the power density can be derived by,

$$\sigma = \frac{P_{in} \eta_a}{A_{eff}} = \frac{4\pi P_{in} \eta_a}{\lambda_0^2 G_r} \quad (2)$$

where  $P_{in}$  is the input power of the rectifying circuit.  $A_{eff}$  is the effective area of the rectenna,  $\lambda_0$  is the wavelength in free space,  $\eta_a$  is the antenna radiation efficiency and  $G_r$  is the gain of receiving antenna. Based on (1)-(2), since the input power to the rectifying circuit  $P_{in}$  is configured at -10~25 dBm, the incident power density to the rectenna can be subsequently calculated which varies from 8.6  $\mu\text{W}/\text{cm}^2$  to 27.3  $\text{mW}/\text{cm}^2$  at 5.8GHz. The rectenna was placed in free space to collect the RF power, and then converted the captured RF power to DC power. A multimeter was used to measure the dc power across a load resistor  $R_L$  of 220  $\Omega$ .

The simulated (measured) conversion efficiency is displayed in Fig. 5 (b), where high conversion efficiency ( $\eta_c > 50\%$ ) can be achieved under the input power range of 38 dB (35 dB in

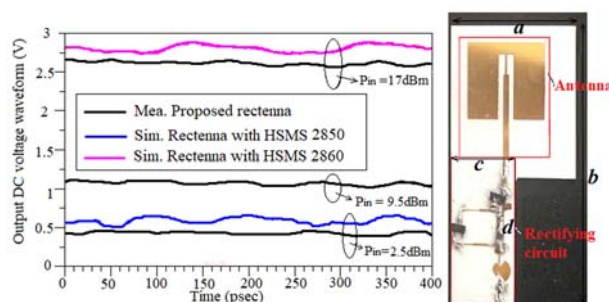

Fig. 6. Output DC voltage waveform and fabricated rectenna. (a=25mm, b=47mm, c=12mm, d=21mm)

measurement). The maximum conversion efficiency reaches 73.74% (70.25% in measurement) at the input power of 9.5 dBm. Also, the performance of the rectifiers using a single HSMS 2860 diode and a single HSMS 2850 diode are added to Fig. 5 (b) for comparison. It can be seen that the conversion efficiency of 51.24%~70.48% can be obtained at the input power of -13~14 dBm for the rectenna using HSMS 2850 only, while the efficiency is around 50.7%~74.45% at a different input power range of 5~30 dBm for the case of HSMS 2860 only. It should be noted that an intersection region between the aforementioned two optimum input power ranges is achieved, and the operation ranges of the two diodes can be effectively combined for a wide input power range of the proposed rectenna, therefore extending the input power range with high efficiency (> 50%) significantly. On the other hand, it is found that the measured efficiency is lower than the simulated result, which might be due to the actual parasitic parameters of the components, such as the series resistance and the junction capacitor of the diodes. The realistic parasitic element is slightly different from the simulated SPICE model in ADS simulation, leading to the mismatching between the antenna and circuit.

Also, the measured output DC waveforms are shown in Fig. 6, where the simulated output waveform of the rectenna with a single HSMS 2850 (a single HSMS 2860) is displayed at the input power of 2.5 dBm (17 dBm). Such power levels are selected for the optimal conversion efficiency realized by using different diodes. Due to the high order harmonics recycling, the proposed rectenna can generate smoother DC waveforms, compared to the ones using a single HSMS 2850 or HSMS 2860 without the function of harmonic recycling.

The proposed rectenna is compared with some relevant work for a wide input power range and some previous 5.8 GHz rectennas, as shown in Table I. Differing from the state-of-the-art wide-input-power rectenna designs in [3]-[10], our design has achieved a relatively wide power range (35 dB) at a higher operation frequency of 5.8 GHz by using a simpler structure and less-complicated design concept. We should clarify that the proposed rectenna is realized at a much higher frequency of 5.8 GHz (with larger component loss introduced by diodes and surface-mounted device components), the conversion efficiency is reasonably good, which is comparable with that of the state-of-the-art 5.8 GHz rectennas in such as [13] (54%) and [14] (64.8%). Although the highest maximum conversion efficiency or the widest input power range in Table I was achieved for the work using active switches [5]-[9], our design still shows competitive overall efficiency and power range compared with these low-frequency designs. The proposed rectenna can be easily extended to high/low frequency and high/low power operation without the consideration of linearity and thermal effects of the active components (FET, MOSFET etc.). Also, the additional biasing network for active/passive diodes is not required in our design, which could reduce the cost, complexity and size of the rectifying circuit. Due to the mid-inductor, the sub-rectifier can be eliminated and combined to a single circuit. Without using the sub-rectifier, a size reduction of 30% can be achieved compared to [10]. According to the quotation from the manufacturer, the fabrication cost of our work is also less than (48% price reduction, compared to [10]) the ones who need a

TABLE I  
COMPARISON OF WIDE-INPUT-POWER RECTIFYING CIRCUITS AND 5.8 GHz RECTIFYING CIRCUITS

Ref.	Freq. (GHz)	Pin range for conversion efficiency>50% (dBm)	Circuit Size (cm <sup>2</sup> )	Max. Eff. (%)	Method
[3]	2.45	20~30	-	70	TLRCN
[4]	2.45	8.5~32.5	-	63	Coupler
[5]	1.8	-4~30	-	75	SP4T
[6]	2.45	-3~22	6.1×2.2	78	SPDT
[7]	0.1	-14~21	5.4×5.4	75	FET
[8]	0.05	-13.5~16.7	5.0×3.8	70	MOSFET
[9]	0.915	-12~28	-	80	Transistors
[10]	2.4	-3.5~26	5.5×3.8	72.8	Cooperative
[13]	5.8	0	-	54	Differential
[14]	5.2 /5.8	13.5~17 /14.5~15.5	2.4×1.7	65.2 /64.8	PIN
This work	5.8	-10~25	2.1×1.2	70.2	Cooperative

larger PCB and more soldering and via-hole tasks. Evidently, our proposed rectenna is simpler and more compact.

#### IV. CONCLUSION

A simple and compact rectenna using two different diodes has been proposed for a wide input power range (over 35 dB). Due to the introduction of the mid-inductor, the sub-rectifier can be significantly simplified to a single rectifying circuit branch with a much-reduced complexity. Furthermore, the size of the proposed rectenna has been effectively miniaturized, while the overall power conversion efficiency against power and frequency has been further improved with the aid of the harmonics recycling. The experimental efficiency of the proposed rectenna example was over 50% (up to 70%) within an input power range from -10 to 25 dBm at 5.8 GHz. As our future work, ultra-low-loss diodes (e.g., spindiodes) could be used to build the proposed wide-power-range rectifier structure for lower input power (<-20dBm) ambient wireless energy harvesting applications.

#### REFERENCES

- [1] Y. M Zhang, T. Lu, Z. M. Zhao, et al., Selective wireless power transfer to multiple loads using receivers of different resonant frequencies, *IEEE Trans. Power Electron.*, vol. 30, no. 11, pp. 6001-6005, Nov. 2015.
- [2] Z. Zhang, H. Pang, A. Georgiadis, and C. Cecati, "Wireless power transfer—An overview," *IEEE Trans. Ind. Electron.*, vol. 66, no. 2, pp. 1044–1058, Feb. 2019.
- [3] T. W. Barton, J. Gordonson, and D. J. Perreault, "Transmission line resistance compression networks for microwave rectifiers," *IEEE MTT-S Int'l Microw. Symp.* (IMS2014), Tampa, USA.
- [4] Y.-Y. Xiao, Z. -X. Du, and X.Y. Zhang, "High-efficiency rectifier with wide input power range based on power recycling". *IEEE Trans. Circuits Syst. II: Express Briefs*, vol. 65, no. 6, pp. 744-748, 2018.
- [5] V. Marian, C. Vollaie, et. al., "Potentials of an adaptive rectenna circuit," *IEEE Antenna and Wireless Propag. Lett.*, vol. 10, pp.1393-1396, 2011.
- [6] F. Mirzavand, V. Nayyeri, M. Soleimani, R. Mirzavand, Efficiency improvement of WPT system using inexpensive auto-adaptive impedance matching, *Electron. Lett.*, vol. 52, no. 25, pp. 2055–2057, Dec. 2016.
- [7] H. Sun, Z. Zhong, and Y.-X. Guo, "An adaptive reconfigurable rectifier for wireless power transmission", *IEEE Microw. Wireless Compon. Lett.*, vol. 23, on. 9, 2013.

- [8] H. Sun, Y.-X. Guo, and Z. Zhong, "A novel rectifier for wireless power transmission with a wide input power range". *2013 IEEE Int. Workshop Electromagnetics, Applications Student Innovation Competition*, pp. 84-87, 2013.
- [9] A. M. Almohaimed, M.C. Yagoub, and R. E. Amaya, "Efficient harvester with active load modulation and wide dynamic input power range for wireless power transfer applications". *2017 Annual IEEE Int. Systems Conf. (SysCon)*, pp. 1-4.
- [10] S. Y. Zheng, S. H. Wang, K. W. Leung, et.al., "A high-efficiency rectifier with ultra-wide input power range based on cooperative structure," *IEEE Trans. Microw. Theory. Tech.*, vol. 67, no. 11, pp. 99, 2019.
- [11] "HSMS 28XX, Surface Mount RF Schottky Barried Diodes," Hewlett Packard Tech. (1998). [Online]. Available: [http://www.hp.Woodshot.com/hprfhelp/4\\_downld/products/diodes/hsms28XX.pdf](http://www.hp.Woodshot.com/hprfhelp/4_downld/products/diodes/hsms28XX.pdf). accessed on 2009.
- [12] R. Mirzavand, M. M. Honari, and P. Mousav, "An efficient power recycling method for multi-port receivers," *2016 IEEE MTT-S Int. Microw. Symp. (IMS)*, San Francisco, CA, 2016, pp. 1-4.
- [13] P. Zhang, Y. M. Chang, M. Zhang, et al., "A 5.8GHz differential rectenna for microwave energy harvesting," *2018 Int. Conf. Microw. Millimeter Wave Tech. (ICMMT)*, pp.1-3, May. 2018.
- [14] P. Lu, X. Yang, J. Li, and B. Wang, "A compact frequency reconfigurable rectenna for 5.2- and 5.8-GHz wireless power transmission," *IEEE Trans. Power Electron.*, vol. 30, no. 11, pp. 6006– 6010, Nov. 2015