



Turner, M. C., & Herrmann, G. (2014). A non-square sector condition and its application in deferred-action anti-windup compensator design. *Automatica*, 50(1), 268-276. 10.1016/j.automatica.2013.10.007

Peer reviewed version

Link to published version (if available):
[10.1016/j.automatica.2013.10.007](https://doi.org/10.1016/j.automatica.2013.10.007)

[Link to publication record in Explore Bristol Research](#)
PDF-document

University of Bristol - Explore Bristol Research

General rights

This document is made available in accordance with publisher policies. Please cite only the published version using the reference above. Full terms of use are available:
<http://www.bristol.ac.uk/pure/about/ebr-terms.html>

Take down policy

Explore Bristol Research is a digital archive and the intention is that deposited content should not be removed. However, if you believe that this version of the work breaches copyright law please contact open-access@bristol.ac.uk and include the following information in your message:

- Your contact details
- Bibliographic details for the item, including a URL
- An outline of the nature of the complaint

On receipt of your message the Open Access Team will immediately investigate your claim, make an initial judgement of the validity of the claim and, where appropriate, withdraw the item in question from public view.

A non-square sector condition and its application in deferred-action anti-windup compensator design

Matthew C. Turner^a, Guido Herrmann^b,

^a*Department of Engineering, University of Leicester, Leicester, LE1 7RH, UK.*

^b*Department of Mechanical Engineering, University of Bristol, Bristol, BS8 1TR, UK.*

Abstract

A sector condition for two connected deadzone nonlinearities is provided. By introducing an additional non-square operator which exploits their connectivity, a more general set of sector-like matrix inequalities is obtained. This “non-square” matrix inequality condition is applied to an anti-windup (AW) problem in which the AW compensator is not activated until the unconstrained control signal reaches a well-defined level beyond that of the physical actuator limits. The non-square sector condition allows such “deferred-action” AW synthesis to be performed in a manner much closer to traditional (“immediate”) sector-based AW with either lowered conservatism or decreased computational effort in contrast to recent work. The non-square condition is applicable to other AW problems.

Key words: anti-windup, saturation, constrained control

1 Introduction

Anti-windup (AW) compensation is a well-established method for enhancing a controller’s performance in the presence of control signal saturation. In this approach, a linear controller is designed, possibly in ignorance of the constraints, and then a so-called AW compensator is added to assist the linear controller during, and following, periods of control signal saturation; the goal being to ensure the saturated system maintains stability and that performance degradation is minimal. Normally, the AW compensator is activated upon the occurrence of saturation. The subject of AW is now fairly mature and the reader is referred to the surveys [29,6], the edited volume [28] and the monographs [7,11,36]. In addition, two earlier papers [16,3] describe and connect some of the early work on AW.

Many modern approaches to AW design are based on tools from convex optimisation ([18,13,9,31,8,21,19,21,5,1,17]) and although these provide an attractive framework for AW synthesis, the compensators produced can be *conservative*: while stability is guaranteed, observed time-domain performance may be disappointing. This has two main sources: (i) the quadratic Lyapunov functions and sector bounds used in the synthesis algorithms; and (ii) the linearity of the AW compensator, which means its behaviour is identical for both small and large excursions beyond the control limits. Thus,

Email addresses: mct6@le.ac.uk (Matthew C. Turner), g.herrmann@bristol.ac.uk (Guido Herrmann).

“modern” AW schemes may provide mediocre performance over part of their operating range. While it is possible to address AW problems with non-quadratic Lyapunov functions and, more generally with IQCs ([14]), these approaches are normally accompanied by non-convex synthesis conditions.

To overcome the above shortcomings, [35] proposed a non-linear AW scheme in which several AW gains were scheduled as a function of the saturation level: for small saturation levels, aggressive AW gains were used for improved performance, while for large saturation levels, less aggressive gains were used in order to preserve stability. Similarly, [30] proposed preliminary results on a “two-stage” AW procedure where, mild saturation was handled by an aggressive AW compensator, and more severe saturation by a less aggressive AW compensator for global stability preservation.

Recently, two other nonlinear AW techniques aimed at enhancing saturated performance have emerged: the so-called *deferred-action* (or *delayed*) AW approach, in which the AW compensator is not activated until the demanded, i.e. unconstrained, control signals reach values beyond the physical actuator limits [22,23]; and the *anticipatory* AW approach [32,34] in which the AW compensator is activated *before* the control signal reaches saturation. Both approaches rely on activating the AW compensator with a saturation function (equivalently a deadzone function) with different limits to those of the physical actuators. The original *deferred-action* scheme of [22] involved writing the system equations in pseudo-LPV form and then using a scaled small

gain approach to guarantee stability. Although examples undoubtedly demonstrated the appeal of the “delayed” AW approach, there are a number of issues with the scheme: the pseudo-LPV modelling of the system meant that 2^m sets of LMI’s needed to be solved, obviously making the approach unattractive when the number of control inputs, m , is large; and the order of compensator produced is of the combined order of the plant (n_p) and controller (n_c), whereas standard full-order approaches ([9]), only require n_p states for optimal performance. In later work [24–26], some of these problems were addressed by using a sector-approach. However, it will be shown that this sector approach [25] is conservative and is implied by the results proposed here.

This paper considers at first two deadzone functions related through their deadzone limits. Exploiting this relationship, an extra difference operator between the deadzones provides a non-square, nonlinear operator together with four (matrix) inequalities. This non-square sector condition is applied with the \mathcal{S} -procedure [2] to the deferred-action AW problem proposed by [22]. The arising deferred-action AW synthesis conditions are much closer to those found in the standard (“immediate”) case of [9]: the LMI’s are of similar complexity, and contain the inequalities of [9] as special cases, unlike the LPV-based results in [22,26]; the increase in complexity as the number of control inputs increased is linear rather than polynomial (as for [22]). It will also be shown that the results derived here are less conservative than the sector-based results found in [26]. The non-square sector results are generic and can be applied to other similar AW problems [32,34,33,30,25].

1.1 Notation

$M \in \mathbb{R}_+^{n \times n}$ means that the real $n \times n$ matrix M is positive definite; $M \in \mathbb{D}_+^{n \times n}$ means that it is diagonal and $M \in \mathbb{R}_+^{n \times n}$. Following [32], $I[1, m]$ denotes the set $\{1, \dots, m\}$ for some integer $m > 0$. The \mathcal{L}_2 norm of a vector valued function $x(t)$ is defined as $\|x\|_2 := (\int_0^\infty \|x(t)\|^2 dt)^{1/2}$ where $\|\cdot\|$ denotes the Euclidean norm; any signal whose \mathcal{L}_2 norm is finite is denoted $x(t) \in \mathcal{L}_2$. The nonlinear operator, $\mathcal{T} : w \mapsto z$ is said to have \mathcal{L}_2 gain less than γ if $\|z\|_2 < \gamma \|w\|_2 + \beta$ for scalars $\gamma, \beta \geq 0$ and $w \in \mathcal{L}_2$. The saturation and deadzone, $\text{Sat}_{\bar{u}}(\cdot), \text{Dz}_{\bar{u}}(\cdot) : \mathbb{R}^m \mapsto \mathbb{R}^m$ are defined via $\bar{u} = [\bar{u}_1 \dots \bar{u}_m]'$ and $\bar{u}_i > 0, i \in I[1, m]$:

$$\text{Sat}_{\bar{u}}(u) = [\text{sat}_{\bar{u}_1}(u_1) \dots \text{sat}_{\bar{u}_m}(u_m)]'$$

$$\text{Dz}_{\bar{u}}(u) = [\text{Dz}_{\bar{u}_1}(u_1) \dots \text{Dz}_{\bar{u}_m}(u_m)]'$$

$$\text{sat}_{\bar{u}_i}(u_i) = \text{sign}(u_i) \min\{|u_i|, \bar{u}_i\}, \text{Sat}_{\bar{u}}(u) = u - \text{Dz}_{\bar{u}}(u)$$

2 A non-square sector condition

The deadzone functions $\text{Dz}_{\bar{u}^{[1]}}(\cdot), \text{Dz}_{\bar{u}^{[2]}}(\cdot) : \mathbb{R}^m \mapsto \mathbb{R}^m$:

$$q^{[1]} = \text{Dz}_{\bar{u}^{[1]}}(u), \quad q^{[2]} = \text{Dz}_{\bar{u}^{[2]}}(u)$$

lead, assuming $\bar{u}_i^{[2]} > \bar{u}_i^{[1]}$, to the decentralised operator $\mathcal{D}_{\bar{u}^{[1]}, \bar{u}^{[2]}}(\cdot) : \mathbb{R}^m \mapsto \mathbb{R}^m$ defined below.

$$\mathcal{D}_{\bar{u}^{[1]}, \bar{u}^{[2]}}(u) := \text{Dz}_{\bar{u}^{[1]}}(u) - \text{Dz}_{\bar{u}^{[2]}}(u), \quad \bar{u}_i^{[2]} > \bar{u}_i^{[1]}, \quad (1)$$

The i 'th element of the $\mathcal{D}_{\bar{u}^{[1]}, \bar{u}^{[2]}}(u)$ is denoted $\mathcal{D}_i(u_i)$. The non-square sector condition requires a preliminary result:

Lemma 1 Given $\mathcal{D}_{\bar{u}^{[1]}, \bar{u}^{[2]}}(\cdot) : \mathbb{R}^m \mapsto \mathbb{R}^m$ in (1) and α_i as

$$\alpha_i := \frac{\bar{u}_i^{[2]} - \bar{u}_i^{[1]}}{\bar{u}_i^{[2]}}, \quad \bar{u}_i^{[2]} > \bar{u}_i^{[1]} \quad (2)$$

then the following properties hold for all $i \in I[1, m]$:

- (a) $\text{sign}\{\alpha_i u_i - \mathcal{D}_i(u_i)\} = \begin{cases} \text{sign}(u_i) & \text{for } |u_i| \neq \bar{u}_i^{[2]} \\ 0 & \text{elsewhere} \end{cases}$
- (b) $\text{sign}\{\mathcal{D}_i(u_i)\} = \begin{cases} \text{sign}(u_i) & \text{for } |u_i| > \bar{u}_i^{[1]} \\ 0 & \text{for } |u_i| \leq \bar{u}_i^{[1]} \end{cases}$

Proof. Item (a): From (2), the left of (a) is equivalent to

$$\chi_i(u_i) := \text{sign}\left\{(\bar{u}_i^{[2]} - \bar{u}_i^{[1]})u_i - \bar{u}_i^{[2]}\mathcal{D}_i(u_i)\right\} \quad (3)$$

Assume $|u_i| < \bar{u}_i^{[1]}$. Equation (3) and $\bar{u}_i^{[2]} > \bar{u}_i^{[1]}$ give:

$$\chi_i(u_i) = \text{sign}\left\{(\bar{u}_i^{[2]} - \bar{u}_i^{[1]})u_i\right\} = \text{sign}(u_i). \quad (4)$$

Assume $|u_i| \in [\bar{u}_i^{[1]}, \bar{u}_i^{[2]})$. In this case, equation (3) gives:

$$\begin{aligned} \chi_i(u_i) &= \text{sign}\left\{(\bar{u}_i^{[2]} - \bar{u}_i^{[1]})u_i - \bar{u}_i^{[2]}\text{sign}(u_i)(|u_i| - \bar{u}_i^{[1]})\right\} \\ &= \text{sign}\left\{(\bar{u}_i^{[2]} - |u_i|)\bar{u}_i^{[1]}\text{sign}(u_i)\right\} = \text{sign}(u_i) \end{aligned} \quad (5)$$

Assume $|u_i| > \bar{u}_i^{[2]}$. In this case, $\chi_i(u_i) = \text{sign}(u_i)$, as:

$$\begin{aligned} \chi_i(u_i) &= \text{sign}\left\{(\bar{u}_i^{[2]} - \bar{u}_i^{[1]})u_i - \bar{u}_i^{[2]}\text{sign}(u_i)(-\bar{u}_i^{[1]} + \bar{u}_i^{[2]})\right\} \\ &= \text{sign}\left\{(\bar{u}_i^{[2]} - \bar{u}_i^{[1]})\text{sign}(u_i)(|u_i| - \bar{u}_i^{[2]})\right\} \end{aligned}$$

Assume $|u_i| = \bar{u}_i^{[2]}$. In this case, $\chi_i(u_i) = 0$.

Item (b): This proceeds in three stages:

Assume $|u_i| < \bar{u}_i^{[1]}$. By calculation, $\text{sign}\{\mathcal{D}_i(u_i)\} = 0$.

Assume $|u_i| \in [\bar{u}_i^{[1]}, \bar{u}_i^{[2]})$. In this case

$$\text{sign}\{\mathcal{D}_i(u_i)\} = \text{sign}\left\{\text{Dz}_{\bar{u}_i^{[1]}}(u_i)\right\} \quad (6)$$

Assume $|u_i| \geq \bar{u}_i^{[2]}$. In this case we have

$$\text{sign}\{\mathcal{D}_i(u_i)\} = \text{sign}(u_i)(\bar{u}_i^{[2]} - \bar{u}_i^{[1]}) = \text{sign}(u_i)$$

which ends the proof \square

It is now possible to define a static nonlinear operator $\Pi_{\bar{u}^{[1]}, \bar{u}^{[2]}}(\cdot) : \mathbb{R}^m \mapsto \mathbb{R}^{2m}$ as

$$\begin{bmatrix} q^{[12]} \\ q^{[2]} \end{bmatrix} = \Pi_{\bar{u}^{[1]}, \bar{u}^{[2]}}(u) := \begin{bmatrix} \mathcal{D}_{\bar{u}^{[1]}, \bar{u}^{[2]}}(u) \\ \text{Dz}_{\bar{u}^{[2]}}(u) \end{bmatrix} \quad (7)$$

Lemma 1 can be used to obtain the following result.

Lemma 2 (Non-square sector condition) *The operator $\Pi_{\bar{u}^{[1]}, \bar{u}^{[2]}}(\cdot) : \mathbb{R}^m \mapsto \mathbb{R}^{2m}$ from (7) satisfies, for all $W_{11}, W_{12}, W_{21}, W_{22} \in \mathbb{D}_+^{m \times m}$ and $u \in \mathbb{R}^m$:*

$$\mathcal{S}_1 := \mathcal{D}_{\bar{u}^{[1]}, \bar{u}^{[2]}}(u)' W_{11} (\mathcal{A}u - \mathcal{D}_{\bar{u}^{[1]}, \bar{u}^{[2]}}(u)) \geq 0 \quad (8)$$

$$\mathcal{S}_2 := \text{Dz}_{\bar{u}^{[2]}}(u)' W_{12} (\mathcal{A}u - \mathcal{D}_{\bar{u}^{[1]}, \bar{u}^{[2]}}(u)) \geq 0 \quad (9)$$

$$\mathcal{S}_3 := \mathcal{D}_{\bar{u}^{[1]}, \bar{u}^{[2]}}(u)' W_{21} (u - \text{Dz}_{\bar{u}^{[2]}}(u)) \geq 0 \quad (10)$$

$$\mathcal{S}_4 := \text{Dz}_{\bar{u}^{[2]}}(u)' W_{22} (u - \text{Dz}_{\bar{u}^{[2]}}(u)) \geq 0 \quad (11)$$

where $\mathcal{A} = \text{diag}(\alpha_1, \dots, \alpha_m)$ and α_i is defined in (2).

Proof: First consider the inequality \mathcal{S}_1 . As $\mathcal{D}_{\bar{u}^{[1]}, \bar{u}^{[2]}}(\cdot)$ is decentralised and $W_{11} \in \mathbb{D}_+^{m \times m}$ we have

$$\mathcal{S}_1 = \sum_{i=1}^m \mathcal{D}_i(u_i) W_{11,i} (\alpha_i u_i - \mathcal{D}_i(u_i)) \quad (12)$$

where $W_{11,i}$ denotes the i 'th diagonal element of $W_{11} > 0$. Application of Lemma 1, then implies that $\mathcal{S}_1 \geq 0$. Inequalities \mathcal{S}_2 and \mathcal{S}_3 follow similarly and inequality \mathcal{S}_4 is simply the standard sector inequality ([15]) for the deadzone. \square

Remark 1: The *non-square* vernacular arises because Lemma 2 provides “sector-like” inequalities for the *non-square* nonlinear operator $\Pi_{\bar{u}^{[1]}, \bar{u}^{[2]}}(\cdot) : \mathbb{R}^m \mapsto \mathbb{R}^{2m}$ defined above. Inequality \mathcal{S}_4 is a standard sector inequality ([15]) and inequality \mathcal{S}_1 was introduced in [30], but inequalities \mathcal{S}_2 and \mathcal{S}_3 , relating $q^{[12]}$ and $q^{[2]}$ are new to this paper. \square

Direct calculation verifies the following fact.

Fact 1 *Assume that $\bar{u}_i^{[2]} > \bar{u}_i^{[1]}$ for all $i \in I[1, m]$, then*

$$\text{Dz}_{\bar{u}^{[1]}}(\text{Sat}_{\bar{u}^{[2]}}(u)) = \mathcal{D}_{\bar{u}^{[1]}, \bar{u}^{[2]}}(u) \quad (13)$$

3 A two-stage anti-windup architecture

The non-square sector condition finds natural application in several nonlinear AW problems. Figure 1 depicts the general configuration where \mathbf{P} represents the linear plant, \mathbf{K} the nominal linear controller, $w(t) \in \mathbb{R}^{n_w}$ is the exogenous input (references and disturbances), $y(t) \in \mathbb{R}^{n_y}$ the measured output, $z(t) \in \mathbb{R}^{n_z}$ the performance output,

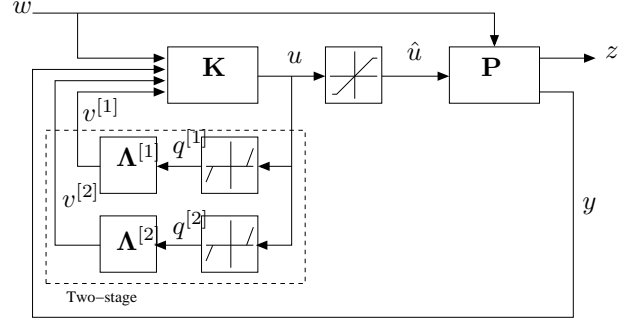

Fig. 1. Two-stage anti-windup architecture

$u(t) \in \mathbb{R}^m$ the demanded (unconstrained) control signal, $\hat{u}(t) = \text{Sat}_{\bar{u}}(u)$ the input to the plant. Two AW compensators appear in the loop: the first, $\Lambda^{[1]}$ is the compensator driven by $q^{[1]} = \text{Dz}_{\bar{u}^{[1]}}(u)$; the second, $\Lambda^{[2]}$ is the compensator driven by $q^{[2]} = \text{Dz}_{\bar{u}^{[2]}}(u)$. These compensators inject corrective signals $v^{[1]}$ and $v^{[2]}$ into the controller.

In Figure 1, typically one compensator would be activated to assist the linear controller when saturation was mild, and the second would be activated upon more severe saturation. This two stage framework was first introduced in [30] and considered, using an equivalent architecture, more recently in [24,25]. There are several special cases of interest:-

- (1) *Immediate AW.* Assume that $\bar{u} = \bar{u}^{[1]}$ and either $\bar{u}_i^{[2]} = \infty \quad \forall i \in I[1, m]$ or $\Lambda^{[2]} \equiv 0$. Then only $\Lambda^{[1]}$ is ever active and activation occurs when “physical” saturation occurs i.e. we have the standard (“immediate” [32]) AW case [9,29,6] considered in most of the literature.
- (2) *Deferred action/Delayed AW.* Assume that $\bar{u} = \bar{u}^{[1]}$ and $\bar{u}_i^{[1]} < \bar{u}_i^{[2]} \quad \forall i \in I[1, m]$. Then if $\Lambda^{[1]} \equiv 0$ (i.e. not present), we have the delayed AW case of [22]. Here, the AW compensator, $\Lambda^{[2]}$, is not activated unless the control signal exceeds some level $\bar{u}_i^{[2]}$, which is itself larger than the physical actuator limits, $\bar{u}_i^{[1]} = \bar{u}_i$.
- (3) *Anticipatory AW.* Assume that $\bar{u} = \bar{u}^{[2]}$ and again that $\bar{u}_i^{[1]} < \bar{u}_i^{[2]} \quad \forall i \in I[1, m]$. Then if $\Lambda^{[2]} \equiv 0$ (i.e. not present), we have the anticipatory AW case of [32]. In this case, $\Lambda^{[1]}$ is activated before the control signal exceeds physical constraints $\bar{u}_i^{[2]} = \bar{u}_i$.

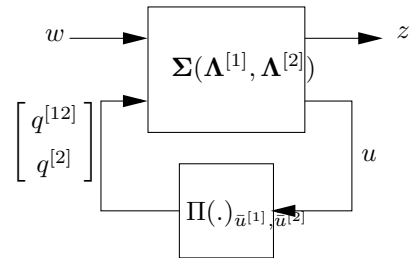

Fig. 2. Two-stage AW problem with operator $\Pi(\cdot)_{\bar{u}^{[1]}, \bar{u}^{[2]}}$

Assuming that $\bar{u} = \bar{u}^{[1]}$, and using the identities $\hat{u} = u - q^{[1]}$ and $q^{[1]} = q^{[12]} + q^{[2]}$, Figure 1 can be re-drawn as Figure

$$\begin{bmatrix} A_p \mathbf{R}_{11} + \mathbf{R}_{11} A'_p + 2AB_2 \mathcal{A} \mathbf{V}_{21} B'_2 & B_2 (\mathcal{A} \mathbf{V}_{21} + \mathbf{V}_{22} - \tilde{\mathbf{U}}_1) & B_1 & \mathbf{R}_{11} C'_1 + 2B_2 \mathcal{A} \mathbf{V}_{21} D'_{12} \\ \star & -2\mathbf{V}_{11} + 2\mathbf{V}_{22} & 0 & (\mathcal{A} \mathbf{V}_{21} + \mathbf{V}_{22} - \tilde{\mathbf{U}}_1) D'_{12} \\ \star & \star & -\gamma I & D'_{11} \\ \star & \star & \star & -\gamma I + D_{12} \mathbf{V}_{21} D'_{12} \end{bmatrix} < 0 \quad (14)$$

$$\begin{bmatrix} \mathbf{S} A'_{CL} + A_{CL} \mathbf{S} & \bar{B}_1 \tilde{\mathbf{U}}_1 + \mathbf{S} C'_{CL} & \bar{B}_w & \mathbf{S} C'_{z,CL} \\ \star & -2\mathbf{V}_{11} + \tilde{\mathbf{U}}_1 \tilde{D}'_1 + \tilde{D}_1 \tilde{\mathbf{U}}_1 & \bar{D}_w & \tilde{\mathbf{U}}_1 \tilde{D}'_{z1} \\ \star & \star & -\gamma I & \bar{D}'_{zw} \\ \star & \star & \star & -\gamma I \end{bmatrix} < 0 \quad (15)$$

2 where $\mathcal{T}_{zw} : w \mapsto z$ has the state-space representation

$$\mathcal{T}_{zw} \sim \begin{cases} \begin{bmatrix} \dot{x} \\ u \\ z \end{bmatrix} = \begin{bmatrix} A & B_w & \tilde{B}_1 & \tilde{B}_2 \\ C & D_w & \tilde{D}_1 & \tilde{D}_2 \\ C_z & D_{zw} & \tilde{D}_{z1} & \tilde{D}_{z2} \end{bmatrix} \begin{bmatrix} x \\ w \\ q^{[12]} \\ q^{[2]} \end{bmatrix} \\ \begin{bmatrix} q^{[12]} \\ q^{[2]} \end{bmatrix} = \Pi_{\bar{u}^{[1]}, \bar{u}^{[2]}}(u) \end{cases} \quad (16)$$

where x is the state of \mathcal{T}_{zw} . Σ represents the interconnection of all the linear elements of the system (i.e. that formed using the realisations of plant, controller and AW compensators).

4 An application to deferred-action anti-windup

For reasons of brevity and for the purposes of comparison, the remainder of the paper will concentrate on *deferred-action AW* [22,23,26]. The non-square sector condition will be exploited to yield deferred-action AW synthesis conditions, which are similar to those of the standard AW case [9]. It will be shown, theoretically and numerically, that the nonsquare sector condition provides improvements over the results in [22,26].

In the deferred action AW case, it is assumed that $\Lambda^{[1]} \equiv 0$ and $\Lambda^{[2]} = \Lambda$ has a state-space realisation

$$\Lambda \sim \begin{cases} \dot{x}_{aw} = \Lambda_1 x_{aw} + \Lambda_2 q^{[2]} \\ v = \begin{bmatrix} v_1 \\ v_2 \end{bmatrix} = \underbrace{\begin{bmatrix} \Lambda_{31} \\ \Lambda_{32} \end{bmatrix}}_{\Lambda_3} x_{aw} + \underbrace{\begin{bmatrix} \Lambda_{41} \\ \Lambda_{42} \end{bmatrix}}_{\Lambda_4} q^{[2]} \end{cases} x_{aw} \in \mathbb{R}^{n_{aw}} \quad (17)$$

where $q^{[2]} = D_{z\bar{u}^{[2]}}(u)$. Noting that $v^{[1]} \equiv 0$, it is assumed that $v^{[2]} =: v$. Following [23], the plant and controller are

assumed to have the following state-space realisations

$$\mathbf{K} \sim \begin{cases} \dot{x}_c = A_c x_c + B_{cw} w + B_{cy} y + v_1 \\ u = C_c x_c + D_{cw} w + D_{cy} y + v_2 \end{cases} \quad (18)$$

$$\mathbf{P} \sim \begin{cases} \dot{x}_p = A_p x_p + B_1 w + B_2 \hat{u} \\ z = C_1 x_p + D_{11} w + D_{12} \hat{u} \\ y = C_2 x_p + D_{21} w + D_{22} \hat{u} \end{cases} \quad (19)$$

The plant input is given by $\hat{u} = \text{Sat}_{\bar{u}}(u)$, where $\bar{u} = \bar{u}^{[1]}$.

4.1 Existence Conditions

The main result provides existence conditions for a deferred-action compensator of order n_{aw} for a given \mathcal{A} .

Proposition 1 Consider the interconnection (16) and assume that the matrices $\Delta = (I - D_{cy} D_{22})^{-1}$ and $\tilde{\Delta} = (I - D_{22} D_{cy})^{-1}$ exist and that $\Lambda^{[1]} \equiv 0$. Assume also that, for a given \mathcal{A} , there exist positive definite matrices

$$\mathbf{R} = \begin{bmatrix} \mathbf{R}_{11} & \mathbf{R}_{12} \\ \star & \mathbf{R}_{22} \end{bmatrix}, \mathbf{S} \in \mathbb{R}_+^{(n_p+n_c) \times (n_p+n_c)}, \mathbf{R}_{11} \in \mathbb{R}_+^{n_p \times n_p} \quad (20)$$

positive definite diagonal matrices $\tilde{\mathbf{U}}_1, \mathbf{V}_{11}, \mathbf{V}_{21}, \mathbf{V}_{22} \in \mathbb{D}_+^{m \times m}$, and a scalar γ such that the matrix inequalities (14) and (15) hold together with

$$\mathbf{R} - \mathbf{S} \geq 0 \quad (21)$$

$$\text{rank}(\mathbf{R} - \mathbf{S}) \leq n_{aw} \quad (22)$$

$$\mathcal{A} \mathbf{V}_{11} - \tilde{\mathbf{U}}_1 < 0 \quad (23)$$

$$\mathcal{A} \mathbf{V}_{21} - \mathbf{V}_{22} < 0 \quad (24)$$

where the constant matrices $A_{CL}, \bar{B}_1, C_{CL}, \bar{B}_w, C_{z,CL}, \tilde{D}_1, \bar{D}_w, \tilde{D}_{z1}, \bar{D}_{zw}$ are given in the appendix. Then there exists an AW compensator Λ , (17), which guarantees that the interconnection in equation (16) is globally internally stable¹ and that the \mathcal{L}_2 gain of the map \mathcal{T}_{zw} is less than γ .

¹ For $w(t) \equiv 0$, $\lim_{t \rightarrow \infty} x(t) = 0$ for all $x(0) \in \mathbb{R}^{n_p+n_c+n_{aw}}$

Remark 2: The above inequalities resemble those found in standard *linear* AW ([9]): inequality (14) involves open-loop data; inequality (15) involves closed-loop data; and inequalities (21) and (22) involve the inverse of the Lyapunov matrices. Inequality (15) stipulates that, as global results are sought, the un-saturated closed-loop system must be asymptotically stable; inequality (14) stipulates that the open-loop plant must also be stable. The additional rows/columns in inequalities (15) and (14) and the two additional LMI's, (23) and (24), arise because the controller is required to stabilise the closed-loop alone during periods of mild saturation, before AW-compensator activation. $\square\square$

Proof. The proof parallels that of [9]² but with amendments due to Lemma 2. When $\Lambda^{[1]}(s) \equiv 0$, the state-space realisation of the linear portion of \mathcal{T}_{zw} (Σ in Figure 2) is given by

$$\Sigma \sim \left\{ \begin{array}{l} \begin{bmatrix} \dot{x} \\ u \\ z \end{bmatrix} = \begin{bmatrix} A & B_w & \tilde{B}_1 & \tilde{B}_2 \\ C & D_w & \tilde{D}_1 & \tilde{D}_2 \\ C_z & D_{zw} & \tilde{D}_{z1} & \tilde{D}_{z2} \end{bmatrix} \begin{bmatrix} x \\ w \\ q^{[12]} \\ q^{[2]} \end{bmatrix} \end{array} \right. \quad (25)$$

where $x \in \mathbb{R}^{n_p+n_c+n_{aw}}$ and expressions for the state-space matrices are given in the appendix. This state-space realisation can be alternatively written ([4])

$$\Sigma \sim \left[\begin{array}{c|ccc} A_0 + H'_1 \Lambda G_1 & B_w & \tilde{B}_1 & \tilde{B}_1 + H'_1 \Lambda G_2 \\ \hline C_0 + H'_2 \Lambda G_1 & D_w & \tilde{D}_1 & \tilde{D}_1 + H'_2 \Lambda G_2 \\ \hline C_{z0} + H'_3 \Lambda G_1 & D_{zw} & \tilde{D}_{z1} & \tilde{D}_{z1} + H'_3 \Lambda G_2 \end{array} \right] \quad (26)$$

where the matrix of the AW compensator matrices is:

$$\Lambda := \begin{bmatrix} \Lambda_1 & \Lambda_2 \\ \Lambda_3 & \Lambda_4 \end{bmatrix}.$$

A matrix inequality problem: For \mathcal{T}_{zw} (interconnection of Σ and $\Pi_{\tilde{u}^{[1]}, \tilde{u}^{[2]}}(\cdot)$) to be internally stable with \mathcal{L}_2 gain of $\gamma > 0$, it is sufficient for a matrix $P > 0$ ([9,2]) to satisfy

$$\frac{d}{dt}(x'Px) + \gamma^{-1}\|z\|^2 - \gamma\|w\|^2 < 0 \quad \forall x, w \neq 0 \quad (27)$$

Using Lemma 2, inequality (27) holds for $x, w \neq 0$ if

$$\frac{d}{dt}(x'Px) + \gamma^{-1}\|z\|^2 - \gamma\|w\|^2 + \sum_{i=1}^4 \mathcal{S}_i < 0 \quad (28)$$

² Well-posedness of the control loop can be easily argued via [9].

Using (25), inequality (28) is equivalent to the inequality:

$$\begin{bmatrix} A'P+PA & M_{12} & P\tilde{B}_2+C'\tilde{W}_2 & PB_w & C'_z \\ \star & M_{22} & M_{23} & \tilde{W}_1 D_w & \tilde{D}'_{z1} \\ \star & \star & M_{33} & \tilde{W}_2 D_w & \tilde{D}'_{z2} \\ \star & \star & \star & -\gamma I & \tilde{D}'_{zw} \\ \star & \star & \star & \star & -\gamma I \end{bmatrix} < 0 \quad (29)$$

where

$$M_{12} := P\tilde{B}_1 + C'\tilde{W}_1 \quad (30)$$

$$M_{22} := -2W_{11} + \tilde{W}_1 \tilde{D}_1 + \tilde{D}'_1 \tilde{W}_1 \quad (31)$$

$$M_{23} := \tilde{W}_1 \tilde{D}_2 + \tilde{D}'_1 \tilde{W}_2 - (W_{12} + W_{21}) \quad (32)$$

$$M_{33} := -2W_{22} + \tilde{W}_2 \tilde{D}_2 + \tilde{D}'_2 \tilde{W}_2 \quad (33)$$

and the nonsingular matrices $\tilde{W}_1, \tilde{W}_2 \in \mathbb{D}_+^{m \times m}$ are given by

$$\tilde{W}_1 := \mathcal{A}W_{11} + W_{12} =: \tilde{U}_1^{-1} \quad (34)$$

$$\tilde{W}_2 := \mathcal{A}W_{21} + W_{22} =: \tilde{U}_2^{-1} \quad (35)$$

and, according to Lemma 2, $W_{11}, W_{12}, W_{21}, W_{22} \in \mathbb{D}_+^{m \times m}$.

Projection Lemma. Inequality (29) is equivalent to

$$\Psi_0 + H' \Lambda G + G' \Lambda H < 0 \quad (36)$$

where

$$\Psi_0 = \begin{bmatrix} A'_0 P + P A_0 & \Psi_{0,12} & P\tilde{B}_1 + C'_0 \tilde{W}_2 & P B_w & C'_{z0} \\ \star & M_{22} & \Psi_{0,23} & \tilde{W}_1 D_w & \tilde{D}'_{z1} \\ \star & \star & \Psi_{0,33} & \tilde{W}_2 D_w & \tilde{D}'_{z2} \\ \star & \star & \star & -\gamma I & \tilde{D}'_{zw} \\ \star & \star & \star & \star & -\gamma I \end{bmatrix} \quad (37)$$

$$H = \begin{bmatrix} H_1 P & H_2 \tilde{W}_1 & H_2 \tilde{W}_2 & 0 & H_3 \end{bmatrix} \quad (38)$$

$$G = \begin{bmatrix} G_1 & 0 & G_2 & 0 & 0 \end{bmatrix} \quad (39)$$

and $\Psi_{0,12} = P\tilde{B}_1 + C'_0 \tilde{W}_1$, $\Psi_{0,23} = \tilde{W}_1 \tilde{D}_1 + \tilde{D}'_1 \tilde{W}_2 - (W_{12} + W_{21})$ and $\Psi_{0,33} = -2W_{22} + \tilde{W}_2 \tilde{D}_1 + \tilde{D}'_1 \tilde{W}_2$. From the Projection Lemma [4], (36) holds if and only if

$$W'_G \Psi_0 W_G < 0 \quad \text{and} \quad W'_H \Psi_0 W_H < 0 \quad (40)$$

where W_G and W_H are, respectively, full column rank matrices whose columns span the null spaces of G and H . It is now shown that (14), (15) and (21)-(24) imply (40) and Proposition 1.

Inequality (15). Partitioning the matrix P as ([9])

$$P = \left[\begin{array}{cc|c} P_{11} & P_{12} & P_{13} \\ \star & P_{22} & P_{23} \\ \star & \star & P_{33} \end{array} \right] = \left[\begin{array}{c|c} \mathbf{S}^{-1} & P_{\star} \\ \star & P_{33} \end{array} \right] \quad (41)$$

where $S \in \mathbb{P}_+^{(n_p+n_c) \times (n_p+n_c)}$ and $P_{33} \in \mathbb{P}_+^{n_{aw} \times n_{aw}}$, allows the left-hand inequality in (40) to be reduced to inequality (15) in the proposition.

Inequality (14). Defining $Q := P^{-1}$ and partitioning Q as

$$Q = \left[\begin{array}{cc|c} Q_{11} & Q_{12} & Q_{13} \\ \star & Q_{22} & Q_{23} \\ \star & \star & Q_{33} \end{array} \right] = \left[\begin{array}{c|c} \mathbf{R} & Q_{\star} \\ \star & Q_{33} \end{array} \right]$$

then enables the right-hand inequality in (40) to be written as inequality (14) where

$$\mathbf{V}_{11} = \tilde{\mathbf{U}}_1 W_{11} \tilde{\mathbf{U}}_1 \quad (42)$$

$$\mathbf{V}_{21} = \tilde{U}_2 W_{21} \tilde{U}_2 \quad (43)$$

$$\mathbf{V}_{22} = -\tilde{U}_2 W_{22} \tilde{U}_2 + \tilde{U}_2 (W_{12} + W_{21}) \tilde{\mathbf{U}}_1 \quad (44)$$

Inequalities (21) and (22). As inequality (15) is expressed in terms of \mathbf{S} and inequality (14) in terms of \mathbf{R}_{11} , it is necessary to find conditions which ensure that $P = Q^{-1}$, viz

$$\left[\begin{array}{c|c} \mathbf{S}^{-1} & P_{\star} \\ \star & P_{33} \end{array} \right]^{-1} = \left[\begin{array}{c|c} \mathbf{R} & Q_{\star} \\ \star & Q_{33} \end{array} \right] > 0 \quad (45)$$

According to [20], necessary and sufficient conditions for there to exist matrices P_{\star} , P_{33} , Q_{\star} and Q_{33} satisfying equation (45), is that inequalities (21) and (22) both hold.

Inequalities (23) and (24). Lemma 2 requires the matrices W_{11} , W_{12} , W_{21} , W_{22} to all be diagonal and positive definite. However, the inequalities (14) and (15) have been stated in new variables $\tilde{\mathbf{U}}_1$, \mathbf{V}_{11} , \mathbf{V}_{21} and \mathbf{V}_{22} . While diagonality follows trivially, to see that W_{11} , W_{12} , W_{21} , W_{22} are indeed positive definite, note that

- $\mathbf{V}_{11} > 0$ directly implies $W_{11} > 0$ from equation (42)
- Inequality (23) yields

$$\mathcal{A}\mathbf{V}_{11} - \tilde{\mathbf{U}}_1 = \mathcal{A}\tilde{\mathbf{U}}_1 W_{11} \tilde{\mathbf{U}}_1 - \tilde{\mathbf{U}}_1 < 0 \quad (46)$$

$$\Leftrightarrow \mathcal{A}\tilde{\mathbf{U}}_1 W_{11} \tilde{\mathbf{U}}_1 - \tilde{\mathbf{U}}_1 (\mathcal{A}W_{11} + W_{12}) \tilde{\mathbf{U}}_1 < 0 \quad (47)$$

$$\Leftrightarrow -\tilde{\mathbf{U}}_1 W_{12} \tilde{\mathbf{U}}_1 < 0 \Rightarrow W_{12} > 0 \quad (48)$$

- Equation (44) can be re-written as

$$\mathbf{V}_{22} = \mathcal{A}\mathbf{V}_{21} + \tilde{U}_2 (-\mathcal{A}W_{11} + W_{12}) \tilde{\mathbf{U}}_1 \quad (49)$$

$$= \mathcal{A}\mathbf{V}_{21} - \mathcal{A}\tilde{U}_2 W_{11} \tilde{\mathbf{U}}_1 + \tilde{\mathbf{U}}_1 \mathbf{V}_{21} \tilde{U}_2^{-1} \quad (50)$$

$$(\mathbf{V}_{22} - \mathcal{A}\mathbf{V}_{21}) \tilde{U}_2 = -\mathcal{A}\tilde{\mathbf{U}}_1 W_{11} \tilde{U}_2^2 + \tilde{\mathbf{U}}_1 \mathbf{V}_{21} \quad (51)$$

Note that \mathcal{A} , W_{11} , $\tilde{\mathbf{U}}_1$, \mathbf{V}_{21} are all positive definite and diagonal. Also, by inequality (24), $\mathbf{V}_{22} - \mathcal{A}\mathbf{V}_{21}$ is also positive definite, and diagonal by construction. Therefore, the diagonal elements of \tilde{U}_2 can be obtained as the positive roots of the m quadratic equations defined by (51):

$$\tilde{U}_{2,i} = \frac{-(V_{22,i} - \alpha_i V_{21,i}) + \sqrt{(V_{22,i} - \alpha_i V_{21,i})^2 + 4\alpha_i V_{21,i} \tilde{U}_{1,i} W_{11,i} \tilde{U}_{1,i}}}{2\alpha_i W_{11,i} \tilde{U}_{1,i}} \quad (52)$$

Thus, \tilde{U}_2 can be chosen positive definite. Hence, $\mathbf{V}_{21} > 0$ implies $W_{21} > 0$ from equation (43). Next from (35),

$$W_{22} = \tilde{U}_2^{-1} - \mathcal{A}W_{21} \quad (53)$$

Therefore as \tilde{U}_2 is now known to be positive definite (and thus full rank), $W_{22} > 0$ is equivalent to

$$\tilde{U}_2 - \mathcal{A}\mathbf{V}_{21} > 0 \quad (54)$$

Returning to equation (52), $\tilde{U}_{2,i}$ is

$$\begin{aligned} & \frac{-(V_{22,i} - \alpha_i V_{21,i}) + \sqrt{(V_{22,i} - \alpha_i V_{21,i})^2 + 4\alpha_i V_{21,i} W_{11,i} \tilde{U}_{1,i}}}{2\alpha_i W_{11,i} \tilde{U}_{1,i}} \\ & > \frac{-(V_{22,i} - \alpha_i V_{21,i}) + \sqrt{(V_{22,i} - \alpha_i V_{21,i})^2 + 4\alpha_i V_{21,i} V_{22,i}}}{2\alpha_i W_{11,i} \tilde{U}_{1,i}} \\ & = \frac{\alpha_i V_{21,i}}{\alpha_i W_{11,i} \tilde{U}_{1,i}} > \alpha_i V_{21,i} \end{aligned} \quad (55)$$

This therefore implies inequality (54). In the above derivation the first inequality is due to $\mathbf{V}_{11} > \mathbf{V}_{22}$ implied by inequality (14) and the second inequality is because

$$\tilde{U}_{1,i}^{-1} = \alpha_i W_{11,i} + W_{12,i} > \alpha_i W_{11,i} \Rightarrow \alpha_i W_{11,i} \tilde{U}_{1,i} < 1 \quad (56)$$

□

As with [9], Proposition 1 states non-convex conditions for an AW compensator of arbitrary order (n_{aw}) to exist. Similarly to [9], convex conditions can be obtained when $n_{aw} = 0$ (static AW) and $n_{aw} \geq n_p$. A useful corollary of Proposition 1 is the full-order case given below.

Corollary 1 *For a given \mathcal{A} , there exists an n_p 'th order AW compensator of the form (17) satisfying the properties of Proposition 1 if inequalities (15), (14), (23) and (24) of Proposition 1 are satisfied and, in addition $R_{11} - S_{11} > 0$.*

4.2 Anti-windup compensator construction

The construction of the deferred-action AW compensator, Λ is performed in a similar manner to [9]. In order to obtain Λ , and hence \mathbf{A} , from the data returned by Proposition 1, the following procedure should be followed.

- (1) Obtaining $P > 0$: Similar to [9,4], P can be constructed according to standard re-construction algorithms. Firstly $P_{\star} \in \mathbb{R}^{(n_p+n_c) \times n_{aw}}$ is determined from

$$S^{-1} R S^{-1} - S^{-1} = P_{\star} P_{\star}' \quad (57)$$

Then $P_{33} \in \mathbb{R}^{n_{aw} \times n_{aw}}$ is constructed as

$$P_{33} = I + P'_* S P_* \quad (58)$$

Finally P is constructed according to equation (41).

- (2) $W_{11}, W_{12}, W_{21}, W_{22}$ are obtained using equations (34), (35), (42), (43) and (52).

These matrices are then used to construct Ψ_0, G and H and inequality (36) solved for the AW compensator matrices Λ .

4.3 Relation to existing delayed anti-windup results

This section compares Proposition 1 to two existing deferred-action AW synthesis approaches: the pseudo LPV approach introduced by [23] and used in [22,32]; and the *standard* or *square sector* approach proposed in [25], but also used in earlier *two-stage* AW in work [30].

4.3.1 The pseudo LPV approach ([22])

This approach essentially involves one replacing the (artificial) saturation element by a time-varying gain which takes values in a polytope, and then using this to obtain an LPV-like representation of the system. By convexity, this leads to a number of LMIs involving a common quadratic Lyapunov function which have to be solved at the vertices of the polytope. While we claim no improvement in *performance* over this approach, its downsides are that, in the dynamic case ([22]), the order of the LPV-based compensator is $n_{aw} = n_p + n_c$ (unlike the standard approach in [9] and our results when $n_{aw} = n_p$); also the computational complexity increases rapidly as the number of control inputs increases since the number of matrix inequalities scales as 2^m .

4.3.2 The standard “square” sector approach

This approach was used in [24,25] and is based on the following inequalities, adapted from equations (3) and (4) in [25],

$$Dz_{\bar{u}^{[1]}}(\text{Sat}_{\bar{u}^{[2]}}(u))W(\mathcal{A}\text{Sat}_{\bar{u}^{[2]}}(u) - Dz_{\bar{u}^{[1]}}(\text{Sat}_{\bar{u}^{[2]}}(u))) \geq 0 \quad (59)$$

$$Dz_{\bar{u}^{[2]}}(u)\tilde{W}(u - Dz_{\bar{u}^{[2]}}(u)) \geq 0 \quad (60)$$

where $W, \tilde{W} \in \mathbb{D}_+^{m \times m}$. Note that: (i) there are only two “sector” inequalities above, compared to the four in the non-square sector condition of Lemma 2 (Clearly, it is acknowledged in [26] that sector bounds can be conservative, noting that also two sector inequalities are used in [26]); and (ii) inequality (60) is exactly inequality (4) in Lemma 2, which is a standard sector condition associated with the deadzone. Also, using Fact 1, inequality (59) can be written as

$$\mathcal{D}_{\bar{u}^{[1]}, \bar{u}^{[2]}}(u)W(\mathcal{A}\text{Sat}_{\bar{u}^{[2]}}(u) - \mathcal{D}_{\bar{u}^{[1]}, \bar{u}^{[2]}}(u)) \geq 0 \quad (61)$$

Next, inequality \mathcal{S}_1 in Lemma 2 implies, for $W \in \mathbb{D}_+^{m \times m}$,

$$\begin{aligned} & \mathcal{D}_{\bar{u}^{[1]}, \bar{u}^{[2]}}(u)W(\mathcal{A}u - \mathcal{D}_{\bar{u}^{[1]}, \bar{u}^{[2]}}(u)) \\ &= \mathcal{D}_{\bar{u}^{[1]}, \bar{u}^{[2]}}(u)W(\mathcal{A}(\text{Sat}_{\bar{u}^{[2]}}(u) + Dz_{\bar{u}^{[2]}}(u)) - \mathcal{D}_{\bar{u}^{[1]}, \bar{u}^{[2]}}(u)) \\ &= \mathcal{D}_{\bar{u}^{[1]}, \bar{u}^{[2]}}(u)W(\mathcal{A}\text{Sat}_{\bar{u}^{[2]}}(u) - \mathcal{D}_{\bar{u}^{[1]}, \bar{u}^{[2]}}(u)) \\ & \quad - \mathcal{D}_{\bar{u}^{[1]}, \bar{u}^{[2]}}(u)AWDz_{\bar{u}^{[2]}}(u) \geq 0 \end{aligned} \quad (62)$$

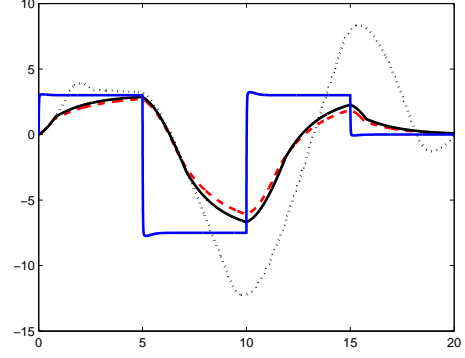

Fig. 3. Circuit example: $y(t)$, large pulse. Nominal linear response: solid blue. Saturated response: dotted black. Immediate anti-windup: dashed red. Delayed anti-windup: solid black

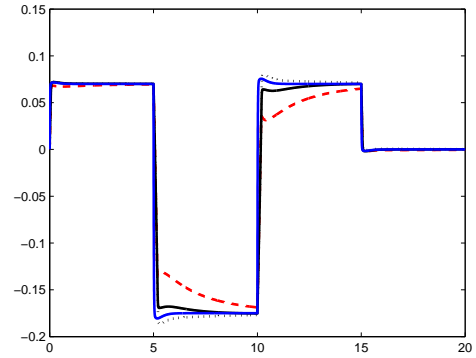

Fig. 4. Circuit example: $y(t)$, small pulse. Nominal linear response: solid blue. Saturated response: dotted black. Immediate anti-windup: dashed red. Delayed anti-windup: solid black

Hence as $\mathcal{D}_{\bar{u}^{[1]}, \bar{u}^{[2]}}(u)AWDz_{\bar{u}^{[2]}}(u) \geq 0$ for all $u \in \mathbb{R}^m$, it follows that inequality \mathcal{S}_1 in Lemma 2 *implies* inequality (59). Therefore, the two inequalities from [25] are implied by two of the inequalities in Lemma 2, but Lemma 2 includes *two additional inequalities not present* in [25] i.e. the *standard sector* results of [25] are conservative and, in fact, are a special case of the non-square condition derived here. Equally, the (standard) sector based deferred-action synthesis conditions reported in [26, Theorem 2] implies greater conservatism (see Sect. 5.3), although the design of an anti-windup compensator of plant order n_p is possible as for [25].

5 Numerical examples

5.1 Circuit Example

Consider the circuit example used in [10,22,23]. The physical control bounds are $\bar{u} = \bar{u}^{[1]} = 1$. A standard full-order “immediate” AW compensator was designed ([9]) yielding a performance bound of $\gamma = 58.46$. A *deferred action* AW compensator was also designed, using Proposition 1 and $\mathcal{A} = \alpha = 0.9$ (meaning that $\bar{u}^{[2]} = (1 - \alpha)^{-1}\bar{u}^{[1]} = 10$) and had an associated performance bound of $\gamma = 61.03$.

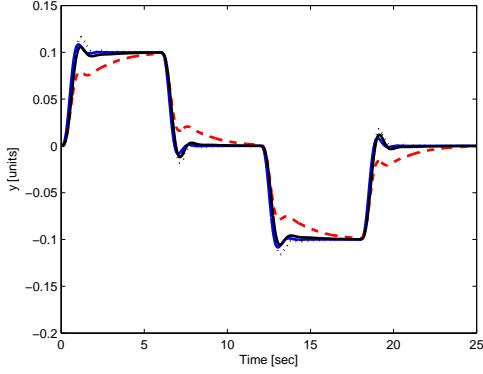

Fig. 5. Hippe’s example: $y(t)$, small pulse. Nominal linear response: solid blue. Saturated response: dotted black. Immediate anti-windup: dashed red. Delayed anti-windup: solid black

Figure 3 shows the response ($y(t)$) of the system to a “large” pulse reference signal. Both AW compensators lead to improved closed-loop performance in the presence of saturation, but performance is somewhat poorer than the linear behaviour. Figure 4 shows the response ($y(t)$) of the system to a “small” reference signal: the immediate AW compensator leads to a sluggish response which is worse than that with no AW, but the delayed AW compensator leads to a response much closer to ideal linear behaviour.

5.2 Hippe’s example

Consider the resonant plant from [12], where the control bounds $\bar{u} = \bar{u}^{[1]} = 1$. Instead of the state-feedback controller suggested in [12], we have used the following \mathcal{H}_∞ loop-shaping controller (see [27]) $\mathbf{K} \sim (A_c, [B_{cy} \ B_{cw}], C_c, [D_{cy} \ D_{cw}])$ and

$$\mathbf{K} \sim \begin{array}{c|cc|cc|cc} \begin{array}{c} 0 \\ 0 \\ 0 \\ 0 \\ \hline 12.50 \end{array} & \begin{array}{c} -72.735 \\ -21.741 \\ 13.316 \\ -0.554 \\ \hline -909.19 \end{array} & \begin{array}{c} -46.978 \\ -17.885 \\ 2.469 \\ 0.081 \\ \hline -587.22 \end{array} & \begin{array}{c} 2.104 \\ 0.752 \\ 0.082 \\ -1.019 \\ \hline 26.30 \end{array} & \begin{array}{c} -40.433 \\ -12.356 \\ 5.941 \\ -0.263 \\ \hline -505.41 \end{array} & \begin{array}{c} 1.583 \\ 0 \\ 0 \\ 0 \\ \hline 19.79 \end{array} \end{array}$$

A full-order immediate AW compensator was designed ([9]), yielding a performance level $\gamma = 12.6919$. A deferred-action compensator with $\mathcal{A} = \alpha = 0.45$ (i.e. $\bar{u}^{[2]} = 1.8182$) with performance level, $\gamma = 25.0223$, was also designed.

When a “large” (magnitude 0.5) pulse demand is applied to the system (not shown), the system without AW becomes unstable. With both the immediate and delayed AW compensator’s stability is maintained although performance is sluggish. Figure 5 shows the responses ($y(t)$) of the system to the same sequence of pulses but with the amplitude reduced to a fifth of its former value: the system without AW behaves well, and as before, better than the system with immediate AW. However, the delayed AW compensator leads to a response much closer to ideal linear behaviour.

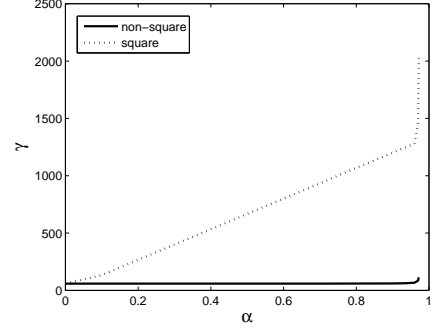

Fig. 6. Comparison of \mathcal{L}_2 gains (γ) for different values of α for the circuit example: Proposition 1 (solid line); results using sector-based results from [26](dotted line)

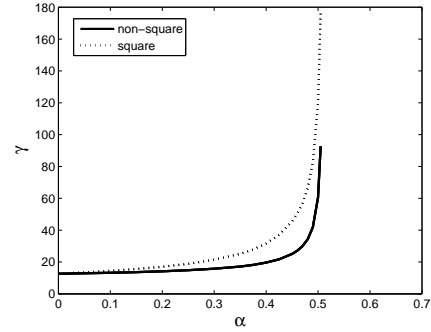

Fig. 7. Comparison of \mathcal{L}_2 gains (γ) for different values of α for Hippe’s example : Proposition 1 (solid line); results using sector-based results from [26](dotted line)

5.3 Choice of \mathcal{A}

A key design parameter is \mathcal{A} , which affects the performance of the deferred-action AW compensator. A similar parameter, $G_d = 1 - \mathcal{A}$ needs to be chosen in the delayed and anticipatory cases ([22,32]). The solid lines in Figures 6 and 7 show how the \mathcal{L}_2 gain of the closed-loop system varies as a function of $\mathcal{A} = \alpha$ when Proposition 1 is used for AW synthesis for the circuit example and Hippe’s example. In both cases, the \mathcal{L}_2 gain remains relatively small for smaller values of α but then increases dramatically beyond a certain point. It is therefore logical to choose α close to where the sudden increase occurs. The dotted line in Figures 6 and 7 shows the \mathcal{L}_2 gain calculated using the “square” sector results of [26]; the \mathcal{L}_2 gains are somewhat higher with this approach. This is not surprising considering the conservatism of the “standard” sector condition, compared to the non-square sector condition proposed in this paper.

6 Conclusions

This paper has introduced a non-square sector condition associated with a static nonlinear operator $\Pi_{\bar{u}^{[1]}, \bar{u}^{[2]}}$ which can be exploited in several different nonlinear AW design problems. Convex synthesis conditions for the specific case of deferred-action AW have been given. It has been shown how these synthesis conditions parallel those in immediate AW

case and how they improve upon existing results available for deferred-action AW synthesis [23,22,25].

A State-space matrices for delayed AW

The state-space matrices of Σ are defined as

$$\begin{bmatrix} A & B_w & \tilde{B}_1 & \tilde{B}_2 \\ C & D_w & \tilde{D}_1 & \tilde{D}_2 \\ C_z & D_{zw} & \tilde{D}_{z1} & \tilde{D}_{z2} \end{bmatrix} = \begin{bmatrix} A_{CL} & B_\Lambda \Lambda_3 & \bar{B}_w & \bar{B}_1 & \bar{B}_1 + B_\Lambda \Lambda_4 \\ 0 & \Lambda_1 & 0 & 0 & \Lambda_2 \\ C_{CL} & D_\Delta \Lambda_3 & \bar{D}_w & \bar{D}_1 & \bar{D}_1 + D_\Delta \Lambda_4 \\ C_{z,CL} & D_\Lambda \Lambda_3 & \bar{D}_{zw} & \bar{D}_{z1} & \bar{D}_{z1} + D_\Lambda \Lambda_4 \end{bmatrix} \quad (\text{A.1})$$

where the linear closed-loop matrices are given by

$$\begin{bmatrix} A_{CL} & \bar{B}_w \\ C_{CL} & \bar{D}_w \\ C_{z,CL} & \bar{D}_{zw} \end{bmatrix} = \begin{bmatrix} A_p + B_2 \Delta D_{cy} C_2 & B_2 \Delta C_c & B_1 + B_2 \Delta (D_{cw} + D_{cy} D_{21}) \\ B_{cy} \tilde{\Delta} C_2 & A_c + B_{cy} \tilde{\Delta} D_{22} C_c & B_{cw} + B_{cy} \tilde{\Delta} (D_{21} + D_{22} D_{cw}) \\ \Delta D_{cy} C_2 & \Delta C_c & \Delta (D_{cw} + D_{cy} D_{21}) \\ C_1 + D_{12} \Delta D_{cy} C_2 & D_{12} \Delta C_c & D_{11} + D_{12} \Delta (D_{cw} + D_{cy} D_{21}) \end{bmatrix} \quad (\text{A.2})$$

and the auxiliary matrices are

$$\begin{bmatrix} \bar{B}_1 & B_\Lambda \\ \tilde{D}_1 & D_\Delta \\ \bar{D}_{z1} & D_\Lambda \end{bmatrix} = \begin{bmatrix} -B_2 \Delta & 0 & B_2 \Delta \\ -B_{cy} \tilde{\Delta} D_{22} & I & B_{cy} \tilde{\Delta} D_{22} \\ -\Delta D_{cy} D_{22} & 0 & \Delta \\ -D_{12} \Delta & 0 & D_{12} \Delta \end{bmatrix} \quad (\text{A.3})$$

where Δ and $\tilde{\Delta}$ are defined in Proposition 1. Also, we have

$$A_0 = \begin{bmatrix} A_{CL} & 0 \\ 0 & 0 \end{bmatrix} \quad C'_0 = \begin{bmatrix} C'_{CL} \\ 0 \end{bmatrix} \quad C'_{z0} = \begin{bmatrix} C'_{z,CL} \\ 0 \end{bmatrix} \quad G_2 = \begin{bmatrix} 0 \\ I \end{bmatrix} \\ G_1 = \begin{bmatrix} 0 & I \\ 0 & 0 \end{bmatrix} \quad H_1 = \begin{bmatrix} 0 & I \\ B'_\Lambda & 0 \end{bmatrix} \quad H_2 = \begin{bmatrix} 0 \\ D'_\Delta \end{bmatrix} \quad H_3 = \begin{bmatrix} 0 \\ D'_\Lambda \end{bmatrix}$$

References

- [1] J.-M. Biannic and S. Tarbouriech. Optimisation and implementation of dynamic anti-windup compensators with multiple saturations in flight control systems. *Control Eng Pract*, 17(6):703–717, 2009.
- [2] S. Boyd, L. El Ghaoui, E. Feron, and V. Balakrishnan. *Linear Matrix Inequalities in System and Control Theory*. SIAM, 1994.
- [3] C. Edwards and I. Postlethwaite. Anti-windup and bumpless-transfer schemes. *Automatica*, 34(2):199–210, 1998.
- [4] P. Gahinet and P. Apkarian. A linear matrix inequality approach to \mathcal{H}_∞ control. *Int J Robust Nonlin*, 4:421–448, 1994.
- [5] S. Galeani, M. Massimetti, A. R. Teel, and L. Zaccarian. Reduced order linear anti-windup augmentation for stable linear systems. *International Journal of Systems Science*, 37:115–127, 2006.
- [6] S. Galeani, S. Tarbouriech, M.C. Turner, and L. Zaccarian. A tutorial on modern anti-windup design. *Eur J Control*, 15(3-4):418–440, 2009.
- [7] A.H. Glattfelder and W. Schaufelberger. *Control systems with input and output constraints*. Springer, London, 2003.
- [8] J. M. Gomes da Silva Jr. and S. Tarbouriech. Anti-windup design with guaranteed regions of stability: an LMI based approach. *IEEE T Automat Contr*, 50(1):106–111, 2005.
- [9] G. Grimm, J. Hatfield, I. Postlethwaite, A.R. Teel, M.C. Turner, and L. Zaccarian. Anti-windup for stable linear systems with input saturation: an LMI based synthesis. *IEEE T Automat Contr*, 48(9):1509–1525, 2003.
- [10] G. Grimm, I. Postlethwaite, A.R. Teel, M.C. Turner, and L. Zaccarian. Case studies using linear matrix inequalities for optimal anti-windup synthesis. *Eur J Control*, 9:463–473, 2003.
- [11] P. Hippe. *Windup in control. Its effects and their prevention*. AIC, Springer, Germany, 2006.
- [12] P. Hippe and C. Wurmthaler. Systematic closed-loop design in the presence of input saturations. *Automatica*, 35:689–695, 1999.
- [13] J.M. Gomes da Silva Jr., S. Tarbouriech, and G. Garcia. Local stabilization of linear systems under amplitude and rate saturating actuators. *IEEE T Automat Contr*, 48(5):842–847, 2003.
- [14] M.L. Kerr, M.C. Turner, E. Villota, S. Jayasuriya, and I. Postlethwaite. A robust anti-windup design procedure for SISO systems. *Int J Control*, 84(2):351–369, 2011.
- [15] H.K. Khalil. *Nonlinear Systems*. Prentice Hall, New Jersey, 1996.
- [16] M.V. Kothare, P.J. Campo, M. Morari, and C.N. Nett. A unified framework for the study of anti-windup designs. *Automatica*, 30(12):1869–1883, 1994.
- [17] G. Li, G. Herrmann, D.P. Stoten, J. Tu, and M.C. Turner. A novel robust disturbance rejection anti-windup framework. *Int J Control*, 84(1):123–137, 2011.
- [18] V.R. Marcopoli and S.M. Phillips. Analysis and synthesis tools for a class of actuator-limited multivariable control systems: a linear matrix inequality approach. *Int J Robust Nonlin*, 6(9-10):1045–1063, 1996.
- [19] E.F. Mulder, M. V. Kothare, and M. Morari. Multivariable anti-windup controller synthesis using linear matrix inequalities. *Automatica*, 2001.
- [20] A. Packard. Gain scheduling via linear fractional transformations. *Syst Control Lett*, 22(2):79–92, 1994.
- [21] M. Saeki and N. Wada. Synthesis of a static anti-windup compensator via linear matrix inequalities. *Int J Robust Nonlin*, 12:927–953, 2002.
- [22] S. Sajjadi-Kia and F. Jabbari. Modified anti-windup compensators for stable plants. *IEEE T Automat Contr*, 54(8):1934–1939, 2009.
- [23] S. Sajjadi-Kia and F. Jabbari. Modified anti-windup compensators for stable plants: Dynamic anti-windup case. In *IEEE Decis Contr P*, Shanghai, 2009.
- [24] S. Sajjadi-Kia and F. Jabbari. Multiple stage anti-windup augmentation synthesis for open-loop stable plants. In *IEEE Decis Contr P*, Atlanta, 2010.
- [25] S. Sajjadi-Kia and F. Jabbari. Multi-stage anti-windup compensation for open-loop stable plants. *IEEE T Automat Contr*, 56(9):2166–2172, 2011.
- [26] S. Sajjadi-Kia and F. Jabbari. Modified dynamic anti-windup through deferral of activation. *Int J Robust Nonlin*, 22(15):1661–1673, October 2012.
- [27] S. Skogestad and I. Postlethwaite. *Multivariable Feedback Control - Analysis and Design*. Wiley, Chichester, 2005.
- [28] S. Tarbouriech, G. Garcia, and A.H. Glattfelder (Eds.). *Advanced strategies in control systems with input and output constraints*. LNCIS, vol.346, Springer, 2007.

- [29] S. Tarbouriech and M.C. Turner. Anti-windup design: an overview of some recent advances and some open problems. *IET Control Theory A*, 3(1):1–19, 2009.
- [30] M.C. Turner, G. Herrmann, and I. Postlethwaite. Improving local anti-windup performance: Preliminary results on a two-stage approach. In *IFAC P World Congr*, Prague, 2005.
- [31] F. Wu and B. Lu. Anti-windup control design for exponentially unstable lti systems with actuator saturation. *Syst Control Lett*, 52(3-4):305–322, 2004.
- [32] X. Wu and Z. Lin. Anti-windup in anticipation of actuator saturation. In *IEEE Decis Contr P*, Atlanta, 2010.
- [33] X. Wu and Z. Lin. Design of multiple anti-windup loops for multiple activations. *Sci China Ser F*, 55(9):1925–1934, 2012.
- [34] X. Wu and Z. Lin. On immediate, delayed and anticipatory activation of anti-windup mechanism: static anti-windup case. *IEEE T Automat Contr*, 57(3):771–777, 2012.
- [35] L. Zaccarian and A.R. Teel. Nonlinear scheduled anti-windup design for linear systems. *IEEE T Automat Contr*, 49(11):2055–2061, 2004.
- [36] L. Zaccarian and A.R. Teel. *Modern Anti-windup Synthesis: Control Augmentation for Actuator Saturation*. Princeton University Press, New Jersey, 2011.