

Performance Evaluation of Portable Hot Water Jet for Frozen Meat Industry Application

Nurul Izzah Khalid^a, Norashikin Ab. Aziz^{a,*}, Farah Saleena Taip^a

^a Department of Process and Food Engineering, Faculty of Engineering, Universiti Putra Malaysia, 43400 Serdang, Selangor, Malaysia
E-mail: *norashikin@upm.edu.my

Abstract— High temperature-induced water jet has important cleaning factors for effective cleaning at food industries because it can provide mechanical, heat, and chemical effects during cleaning. It can also reduce cleaning time, labor load, and utility consumptions, hence reducing the operating costs and enhance sustainability. However, it has not been used widely in small and medium food industries due to a lack of cleaning awareness and small budget allocation for cleaning and disinfection. In this article, we evaluated the performance of a portable water jet in the laboratory before it was introduced to the frozen meat industry. Removal of invisible fat-based fouling deposits which remained on the surfaces of the meat processing equipment is quite a challenge. In this work, stainless steel surfaces were fouled with the fat-based fouling deposit. The fouled stainless-steel surfaces were used for the cleanability tests. The tests were conducted at different parameters which were cleaning parameters (temperature (35 °C and 65 °C) and cleaning detergent presence), cleaning operations (nozzle distances (5 cm and 30 cm)) and surface geometries (vertical and horizontal) which representing the different equipment's geometry. Physical cleanliness (visual and touch) and protein residue swab test was used as the cleaning indicators. The target cleanliness was achieved at a high cleaning temperature of 65°C and with the presence of cleaning detergent. Results from these tests will be used as a guide to design an optimal cleaning program for SMEs frozen meat patty factory.

Keywords— cleaning-out-place (COP); manual cleaning; sanitation program; fouling deposit; high-pressure cleaning; food industry.

I. INTRODUCTION

Effective cleaning is an essential practice in the food industry to comply with legal and technical standards (e.g., Good Manufacturing Practice (GMP), Hazard Analysis and Critical Control Point (HACCP), Food Safety Management). Therefore, hygienic, and comfortable working environment can be maintained, and food hazards are controllable. However, some of the SMEs manufacturers are taking the cleaning process for granted as they are not fully aware of the consequences of the unhygienic environment, such as cross-contaminations (physical, chemical, and biological), dangerous working conditions (slippery floor) and many more. Some of them also have a mindset that they should invest less in cleaning as this process will not generate any extra income. However, they are not aware that proper cleaning can maintain and increase food product quality (shelf life, appearance, sensory). They stated that the cleaning and disinfection program could become a burden as it is costly [1]–[3]. Cleaning costs might include costs for cleaning chemicals, cleaning apparatus, hot water generation, labor cost, and wastewater treatments [1], [4], but all these costs can be reduced with an effective cleaning program. Effective cleaning can result in dramatic increases in

production, a reduction of downtime, water, cleaning chemicals, energy, labor, and wastewater disposal. The cost of labor can account for over 60% of the total cleaning budget [5], and the application of cleaning equipment can reduce this cost.

Daily cleaning is compulsory in food factories. Due to food or organic residues (also known as fouling deposit) are left on the surfaces of processing equipment after every food production. In some food industries, cleaning is performed after every batch of production. Hence, they have more than one cleaning process in a day and more cost for cleaning. The food or organic residues originates from the ingredients of the food product. These residues may include fat, oils, proteins, carbohydrates, starches, and minerals. Every food residue has different physicochemical properties; thus, it is important to establish cleaning process that can remove the residue effectively. Cleaning requirement for dairy industries, which mainly generate protein-based fouling deposit, have been well studied [6]–[9]. However, the cleaning study for frozen meat industries has received less attention. Fat-based food residue is generally found inline production of frozen meat patties, ready to eat food, nuggets, and confectionaries. At the end of production, fat-based fouling deposit (fat layer residues from the food products) can remains on most of food processing equipment surfaces (e.g. mixer, flaker,

mincer and former) and environment (e.g. floor, walls) [10], [11]. Cleaning efficiency depends on the influence of cleaning parameters such as temperature [12], [13], fluid velocity [14], [15] and chemical concentration [16]-[18]. Cleaning performance increased when high temperature, high fluid velocity and high chemical concentration were used. However, optimal cleaning parameters are the main key to avoid excessive cleaning which can harm the health of the environment. Moreover, from the industrial point of view, optimal cleaning parameters will reduce the cleaning costs, reduce downtime and at the same time guarantee the physical, microbiological, and chemical cleanliness [19].

Effective cleaning not only can be achieved by manipulating the cleaning parameters but also by application of cleaning equipment, for instance water jet. The performance of the water jet is influenced by the cleaning operations such as nozzle distances [20]-[22] and cleaning angles [20]. Removal of fouling deposit is more efficient when shorter cleaning distance were used [21], [22]. Cleaning at higher angle of 120° can clean wider dirty area and at the same time reduce cleaning times and cleaning costs (includes water volume, cleaning chemicals and energy) [20]. Hot water rinse is essential to melt and eventually lead to fat-based fouling deposit removal [10]. However, investment on boiler is seem like a burden, as they will also have to hire a boiler man. Employment of a boiler man will eventually increase the monthly operational costs.

There are numerous studies on cleaning-in-place (CIP) for food industries [1], [23]-[25]. However, most of the SMEs Malaysian food factories used batch processing unit and manual cleaning are more suitable [10]. Study on manual cleaning is still lacking. Cleanability study in the factory environment are challenging. Preliminary studies are essential to design a range of tested cleaning parameters before cleanability experiments can be performed in the factory environments.

The aim of this research are to evaluate the performance of a portable water jet in the laboratory before it was introduced to frozen meat industry, and to determine the suitable cleaning parameters (temperatures, cleaning detergent) and cleaning operations (cleaning distance, cleaning angle) using a portable hot water cleaning unit at different cleaning surfaces (horizontal and vertical). This work tested cleanability for the fat-based fouling deposit.

II. MATERIALS AND METHOD

A. Portable Hot Water Jet Cleaning Unit

In this work, a portable hot water cleaning unit was used for the cleanability experiments. This portable unit are equipped with a stainless-steel heater tank that containing a heating element. The heater tank (with a capacity of 100 L) can heated the cleaning solutions up to 110 °C. This portable unit also has a spray gun with a nozzle (even flat spray VNP series, 30° spray angle, spray capacity code 49, H. Ikeuchi & Co., Ltd., Japan), which produced high speed water which can operated at nozzle pressure varying from 5.0 bar to 7.0

bar. This portable hot water cleaning unit was designed and constructed at the Process and Food Engineering laboratory of the Faculty of Engineering, the Universiti Putra Malaysia, Malaysia. (Fig. 1) [10].

B. Preparation of cleaning solutions

In this work, cleanability experiments were performed with and without cleaning chemical. A commercial cleaning chemical (2 in 1 Cleaner and Sanitation, SANICLEAN, SynTech Chemicals, Singapore) was used. SANICLEAN cleaning chemical is one of the common alkaline-based cleaning chemical, which is applied in the cleaning of food plants. The composition of the SANICLEAN cleaning chemical is shown Table 1. In this work, 1.7 L of cleaning chemical were diluted and mixed in 100 L water inside the portable water jet tank.

TABLE I
COMPONENTS IN CLEANING CHEMICAL SANICLEAN (SYNTECH CHEMICALS, SINGAPORE)

Components	Weight (%)	Function
Water	70 - 80	-
Chelating agent	0.5 - 1.5	Preventing detergents reacting with the mineral deposits in hard water and forming detergent scum.
Cocamidopropyl Betaine	10 - 15	Synthetic detergent and surfactant
Lauramine Oxide	1 - 5	Non-ionic/atmospheric surfactant
Sodium Metasilicate	0.5 - 1.0	Cleaning agent
Quaternary ammonium compound	1 - 5	Sanitizing agent
Color dye	<0.001	-

C. Preparation of Fouled Test Object

Minced beef meat (purchased from the local supermarket) was used to develop the physical model for fat-based fouling deposit. To imitate industrial fat-based fouling deposit, 50 g minced meat were pressed down and spread evenly on the 20 cm x 20 cm stainless steel (Type 304) test object. After 1 hour, using a cleaning brush, the minced meat was removed from the test object, leaving only the fat-based fouling deposit. After 1 hour, the fouled test object was used for the cleanability experiments.

In this work, the spray gun was assembled in a static condition inside the cleaning test rig (Fig. 2). Thus, the water jet can only reach and cleaned the middle part of the fouled test object surfaces (approximately 5 cm x 5 cm). Therefore, the cleanliness of the test object was tested on the middle part only. Before soiling with minced beef meat, the stainless-steel test object was pre-cleaned using distilled water and 95% v/v ethyl alcohol (R&M Chemicals, United Kingdom). The purpose of pre-cleaned is to ensure there is no foreign materials exist on the fouled test object before sample preparations.

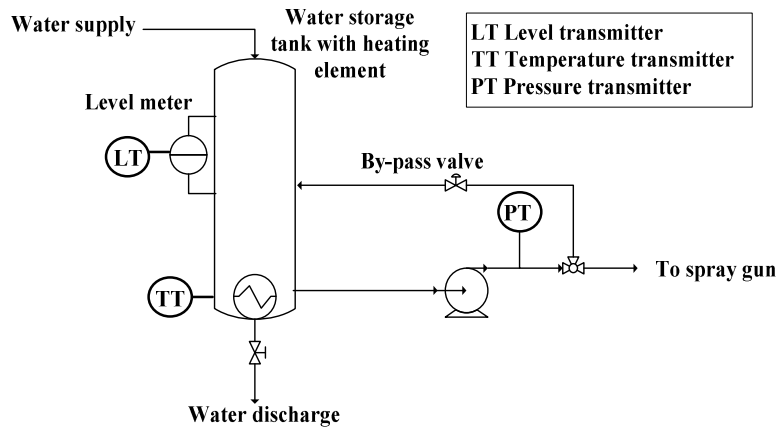
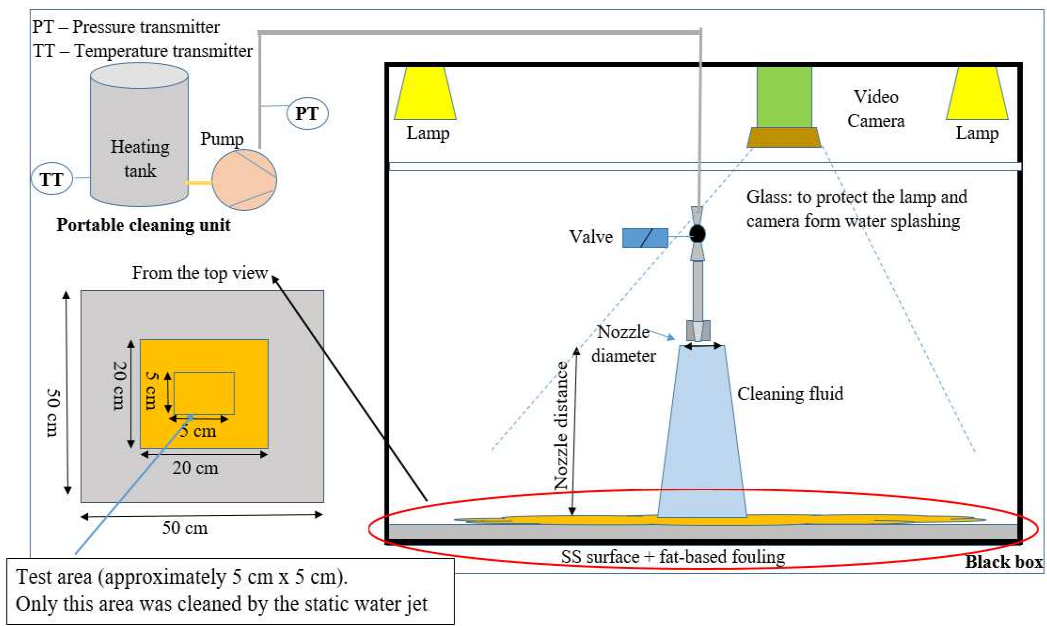
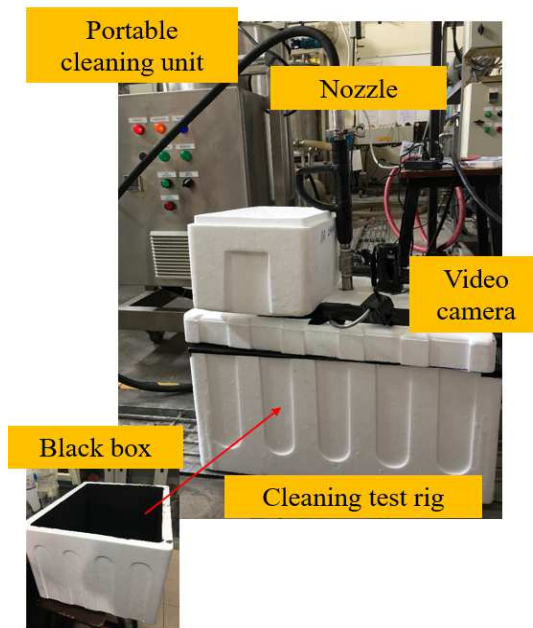

Fig. 1. Portable hot water jet cleaning unit piping and instrumentation diagram [6].



(a)



(b)

Fig. 2. Cleanability experiments set-up (horizontal): a) schematic diagram and b) photograph.

D. Cleaning Test Rig

A cleaning test rig was designed for these cleanability experiments. The cleaning test rig was used to ensure the reproducibility and similarity of the cleanability experiment. A thick big polystyrene (outer: 62 cm x 49 cm x 38 cm, inner: 56 cm x 43 cm x 30 cm) was used to build the cleaning test rig. This cleaning test rig contains a black box, which is used to ensure the light intensity conditions were constant during the cleanability experiments. The inner part of the box was painted black to minimize the reflection of the lights. The flexible lamps only supplied the light source in the cleaning test rig. Two flexible lamps with a light specification of 6500 K (comparable to daylight), were fixed on the top part of the cleaning test rig. It was an ideal light source for experiments as it minimized the color rendering effect [26]. The black box was also responsible for providing insulation against inconsistent environmental light sources.

On the top of the cleaning test rig, a customized hole that can fit the lenses of the video camera was made. Thus, allowing online monitoring or video recording during the cleanability experiments. Besides the video camera's customized hole, an extra customized hole was made to hold the spray gun. It can fit the spray gun tightly and can be used to control cleaning distance and cleaning angles during the cleanability experiments. A thick plastic glass was installed to prevent water from splashing into the lamps and video cameras during the cleanability experiments. This experimental set-up is shown in Fig. 2.

E. Cleanability Experiments

The fouled test object was placed either horizontally or vertically inside the cleaning test rig. Fig. 2 shows the cleanability set-up for cleaning the horizontal surfaces. The spray gun was assembled at different cleaning distance between the nozzle and the fouled test object (5 - 30 cm) and different angle (30 - 90°). A video camera (Panasonic, HDC-SD100) was placed on top of the cleaning test rig to record the removal behaviors of the fat-based fouling deposit and its cleaning time. Cleaning fluid (with or without cleaning detergents) was heated to the desired temperature (35 or 65 °C) and was pumped into the nozzle.

The visual recording was started at the same time as when the cleaning fluid started to spray the fouled test object. The cleaning was performed for 15 minutes. Sufficient contact time or cleaning time is also important to ensure enough chemical reaction time. However, in this work, online visual

monitoring during clean ability experiments is impossible as the water jet causing blurry vision. Thus, the exact cleaning time is hard to know. At the end of the cleanability experiment, the cleaned test object was disassembled from the cleaning test rig. Next, the cleanliness of the test object surface was tested.

F. Cleanliness Target

Physical cleanliness (touch and visual) and protein residue (using rapid protein residue swab test) were used as indicators to validate the cleaning performance. The images of the test objects were captured before and after the cleanability experiments. The remaining fat layer on the test object was determined using touch sensory.

The protein residue that remained on the surfaces was determined using the Path-Check Hygiene Protein swab test (Microgen, United Kingdom). This protein swab was used to detect the presence of protein residue from food contact surfaces and manufacturing equipment in food handling and manufacturing environments. It is a rapid method that allows workers to validate the cleaning process. Moreover, it also can be used as an indicator to decide if the cleaning should be repeated if poor cleaning were performed. The conventional microbiology test method will take a longer time. In this work, the surfaces were considered not clean if it cannot reach physical cleanliness, and there was still protein residue detected.

III. RESULTS AND DISCUSSION

A. Removal of Fat-based Fouling Deposit (Physical Cleanliness)

There is still a lack of studies on the mechanism of the removal of fat-based fouling deposits [10]. Understanding the cleaning mechanism of different types of food residues is essential to design an optimal and efficient cleaning process [1]. The visualization (photograph) of the removal of a fat-based fouling deposit is nearly impossible as it is hard to capture the images of the fat layer remained on the food contact surfaces. Thus, in this work, touch sensory is used to determine the existence of the invisible fat layer remained the stainless-steel surfaces. The cleanability experiment results are shown in Table 2. From naked eyes, the stainless-steel surfaces were visually clean (Run 3). However, the presence of a fat layer on the stainless-steel surfaces was noticed when we touched the surfaces.

TABLE II
LEVEL OF CLEANLINESS AT DIFFERENT CLEANING PARAMETERS

Run	Cleaning parameters				Level of cleanliness		
	Surface geometry	Temperature (°C)	Cleaning chemical	Cleaning distance (cm)	Physical		Protein residue
					Visual inspection	Touch inspection	Protein residue swab test
1	Horizontal	35	No	5	***	✘	NC
2	Horizontal	65	No	5	****	✓	NC
3	Horizontal	35	Yes	5	****	✘	NC
4	Horizontal	65	Yes	5	*****	✓	C
5	Horizontal	35	No	30	***	✘	NC
6	Horizontal	65	No	30	****	✓	NC
7	Horizontal	65	Yes	30	*****	✓	C
8	Vertical	35	No	5	***	✘	NC
9	Vertical	65	No	5	****	✓	NC
10	Vertical	65	Yes	5	*****	✓	C

(Notes: ***** Highest physically visual clean rank, * Lowest physically visual clean rank, ✓ physically clean from fat-based fouling deposit, ✘ Fat-based fouling deposit remained, NC- not clean (protein residue detected), C- clean).

Generally, removal of fouling deposit depends on energy to overcome 1) the adhesive force between the food-contact surfaces and the fouling deposit, and 2) the cohesive force between the fouling deposit itself [1], [10]. The cleaning mechanism of the fat-based fouling deposit [10] is slightly different from the carbohydrate-based fouling deposit [1]. Even though visually, the fouling deposit has left the surfaces (Fig. 3), the invisible fat layer remained and can act as an excellent substrate for hiding or absorbing other food residues and microbes. This uncleaned surface can promote microbial growth and cause cross-contamination to food products, which lead to many foodborne illnesses such as diarrhea, vomiting, and nausea. Extra hot water rinsing step is needed before the cleaning chemicals step [10].

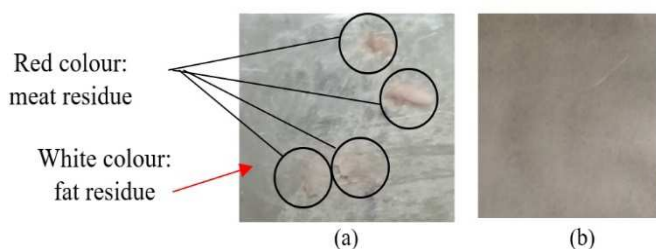

Fig. 3. Physical (visual) cleanliness (a) before and (b) after cleanability experiments.

We suggest sequence cleaning for a fat-based fouling deposit, which consists of 1) removal of the remaining food products, 2) hot water pre-rinse, 3) cleaning chemical-rinse with suitable industrial cleaning brushes, 4) intermediate rinse and 5) hot water disinfection. Hot water disinfection step should also be performed before starting the production on the next day. This is a precaution step to avoid any overnight contamination from any foodborne pathogens such as *Escherichia coli*, *Listeria monocytogenes*, and *Salmonella* [10] and airborne pathogens. This cleaning process is adapted from previous studies [10], [19].

B. Removal of Fat-based Fouling Deposit (Rapid Protein Residue Test)

The protein residue was determined using the protein swab test [10]. The cotton swab was originally in yellow color. The swab cotton turned green within 5 seconds if there were invisible food residues detected on the stainless-steel surfaces (Fig. 4). Results show that cleaning that reached three stars visual cleanliness (Run 1, 5, and 8) cannot be passed the protein swab test. Moreover, even though the test objects surfaces were visually clean with a high rank (4 stars) (Run 2, 6, and 9), the swab cotton still turned green, indicated unclean surfaces. No protein residue was detected on the test object when hot water of 65 °C with cleaning chemicals were used during cleaning (Run 4, 7, 10). Moreover, Run 4, 7, and 10 all reached five stars in visual, physical cleanliness. Cleaning temperature and cleaning chemicals are the essential cleaning parameters during batch and manual cleaning.

Protein swab test is one of a rapid method that can immediately determine the effectiveness of the cleaning program daily. Food manufacturers should consider using a protein swab test to validate their cleaning program. The immediate result obtained using the protein swab test will

help to decide whether the cleaning process should be redone or ended. Effective cleaning (physical clean and no protein residue detected) is crucial to avoid any potential cross-contamination (biological, physical, and chemical).

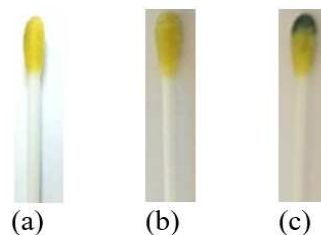

Fig. 4. Path-Check Hygiene Protein cotton swab color (a) original (b) cleaned surface and (c) uncleaned surface.

C. Effect of Cleaning Temperature

The chemical reaction of the cleaning medium is dependent on the cleaning temperature [15], [17], [27]. As the temperature increased, the kinetic energy of the particles increased and initiated the collision between the cleaning medium particles. A high temperature of 70 °C is used to remove pink guava puree fouling deposits from stainless steel surfaces [27]. Also, a high temperature of 80 °C could be used in removing the coconut milk fouling deposit [17]. It is also reported that increased the cleaning temperature higher than 70 °C would not increase the cleaning rate further [27]. From an industrial point of view, extremely high temperature is not favorable as it will require more energy which eventually increases the cleaning costs. Thus, it is very important to determine the optimal cleaning temperature to practice an economical cleaning process.

High temperature cleaning fluid is needed to melt the fat-based fouling deposit to overcome the adhesive force between the fat-based fouling deposit and the stainless-steel equipment surface [10]. Oil or fat fluidity increase with the temperature, which makes it easier to mix with water and be carried away. Cleaning using hot water only at a temperature of 65 °C (Run 2, 6, and 9) are better compared to cleaning performed at 35°C (room temperature) (Run 1, 5, and 8). However, cleaning with hot water at 65 °C only did not reach both physical cleanliness (visual and touch), and there was still protein residue remained on the stainless-steel surfaces. Besides, it is necessary to have hot water pre-rinse step to reduce the cleaning chemicals amount used during the chemical cleaning step. Cleaning chemical is needed to reach the target cleanliness.

D. Effect of Cleaning Chemical

The cleaning chemical is one of the most important cleaning parameters [1], [24], [27]. Food industry manufacturers have a major concern for this chemical cleaning step as it also contributes to the cleaning costs. The cost of the chemical cleaning step is up to 58 % of the total cleaning costs when high concentrations of 2.0 wt.% sodium hydroxide (NaOH) was used [1]. Effective cleaning still can be achieved at lower concentrations NaOH of 1.0 wt. % with the chemical cleaning step only took 43% of the total cleaning costs. The optimal and economical cleaning process is preferable for the food industry manufacturers, as they aim to minimize the operating costs and maximize the profit.

Eliminating the chemical cleaning step can reduce major total cleaning costs. However, without cleaning chemicals,

cleaning cannot be performed effectively [1], [10]. In this work, cleaning was performed with and without cleaning chemicals. Cleaning using water only at 35°C (Run 1, 5, and 8) only achieved three stars visual cleanliness and did not pass the touch cleanliness, and there was still protein residue remained on the stainless-steel surfaces. At 35°C with cleaning detergent (Run 3), physical cleanliness improved (visual: 4 stars). However, it still did not reach the touch of physical cleanliness, and there was still protein residue remained on the stainless-steel surfaces. This indicating the importance of cleaning chemicals for removing fat-based fouling deposits.

When hot cleaning chemicals of 65 °C (Run 4, 7, 10) were used, physical cleanliness was achieved, and no protein residue was detected. A hot cleaning chemical is needed during the chemical cleaning step. A high temperature of cleaning chemicals generally reduces the surface tension, decreases viscosity, and diminishes adsorption [28]. In other words, higher temperature increases the cleaning rate, which significantly can reduce the cleaning time. In this work, the effect of cleaning time does not study. All the cleanability experiments were performed for 15 minutes. The best cleaning parameters obtained from this work can be used as a reference for future studies. Lower cleaning time would be recommended.

The removal of the invisible fat-based fouling layer is one of the challenges faced by producers of frozen meat. This fat-based fouling deposit act as a barrier which prevents any microbes and food residues from being removed [10]. In contact with cleaning chemicals, the invisible fat layer/residues saponified. The cleaning chemical bind with fat residues and reducing the cohesive strength between the fat residues. The adhesive strength between the fat residues and the stainless-steel surfaces weakened as well and led to the detachment of the fat residues. Mechanical action with high velocity using a water jet is needed to eradicate the food residues from the food-contact surfaces.

After cleaning the chemical step, an intermediate water rinse is important to remove the cleaning chemical residues. This step is important to ensure the food contact surfaces are chemically clean. Cleaning chemical residues can cause cross-contamination to food products and lead to food poisoning as well [1].

E. Effect of Cleaning Distance

Several papers had suggested that cleaning using a water jet is more efficient when the shorter distance between the water gun and the target surfaces was used [29], [30]. As the water jet approaching the surfaces, the strong impact of the water jet became stronger and improved the cleaning performance. In contrast, it is suggested that cleaning distance has no significant effect on cleaning performance [10], [31]. In this work, different cleaning distances were tested (5 cm and 30 cm). Results show that cleaning using different cleaning distances have no positive effect on the cleanliness of the test object surfaces. The results obtained from this work seem to agree with the previous studies [10], [31].

Nevertheless, cleaning distance influences the width of the cleaning area. The target cleaning area was wider when a longer cleaning distance of 30 cm was used. This is

illustrated in Fig. 5. Since the water gun is in a stable condition, the cleaned area was too small. For a cleaning distance of 5 cm, the cleaned area width was only approximately 5 cm x 5 cm. From our observation, at a shorter cleaning distance of 5 cm, more water splashed, and landed outside the examined area. The splashed water might contain food product residues and chemical residues that can cause cross-contamination. Moreover, the high-speed hot water can generate aerosol (e.g., water, steam, microbes, dirt, and mist), which can also lead to cross-contamination [10], [32]. In a real factory environment, we want to avoid the water from splashing to other food processing equipment. Future studies using lower water pressure is recommended. In cleaning work, the water jet is moving [31] and not stationary. Cleaning is more efficient, and cleaning time can be as short as 2 minutes. For future studies, a moving water jet would be recommended.

F. Effect of Surface Geometry

In this work, different surface geometry (vertical and horizontal), which represent the different food processing equipment's geometry was tested. The results show that cleaning at either vertical or horizontal surface has no obvious effect. Cleaning performance depends more on the cleaning parameters (cleaning temperatures and cleaning chemicals). The effect of different nozzle angles was not tested as the result of using different surface geometry (vertical and horizontal) does not give any positive effect.

G. Evaluation Performance of the Portable Water Jet

The design of the water jet must meet specific criteria to ensure the objectives of the work can be accomplished. The criteria considered are as follows:

- Portability.
- It can get through the aisle width in food factories.
- It can be pushed or pulled by using human power.
- Provide a pressure accumulation bypass when the spray gun is not triggered during cleaning.
- The water storage tank should be enough to clean up at least a machine at one time.
- The heating element can heat up the cleaning chemicals up to 110°C.

Our water jet meets all the criteria.

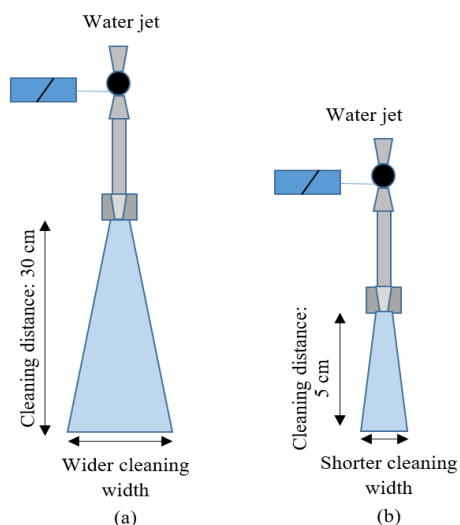

Fig. 5. Effect of cleaning distance on the cleaned area width.

Since it is portable, it can be relocated easily, and workers need less energy to move it. The size of the portable water jet is approximately 1.2 m (length) x 0.58 m (width) x 1.2 m (height). While the minimum aisle width in factory X (a SMEs meat processing factory in Malaysia) is 0.6 m. Therefore, the portable water jet can get through the minimum aisle width. Thus, cleaning for every unit of food processing equipment in the factory can be performed effectively.

Moreover, the portable water jet is a user-friendly machine. Thus, workers can use a portable water jet with just a simple and short training time. It is very important to use user-friendly equipment in a SMEs food factory as most of the workers are foreign workers with low educational background [3], [10].

Based on the results discussed in the previous section, hot water and cleaning chemical are important cleaning parameters to remove the fat-based fouling deposit. This water jet can generate hot water and a high-pressure water jet. The cleaning chemical also can be mixed inside the heater tank. After the tank was full-filled, the hot water portable cleaning unit can operate for 15 to 20 minutes (depends on the water pressure). This indicates the tank capacity of the water jet capable of cleaning several food processing equipment.

In meat frozen industries, equipment such as mixer, former, flaker, and mincer are difficult to clean [10], [11]. This equipment has areas that are difficult to access, and manual cleaning is hard and requires more labor work and time. By using the hot water portable jet, difficult to the clean area such as mixer with a deep tank and a sharp edge can be cleaned easily. Moreover, fat or meat residue that traps on the rough surface conveyer of the former can be cleaned effectively. Sharp blades on the flaker and mincer can be cleaned without any worries on potential hand injuries. In conclusion, this portable water jet is ready to be used in a real working environment.

IV. CONCLUSION

For the frozen meat industry, the removal of a fat-based fouling deposit is one of the cleaning challenges. The invisible fat-based fouling deposit formed barriers that prevented the removal of foodborne pathogens and food residues. The evaluation of the portable water jet showed a positive result. This portable water jet can generate high speed and hot water, which is suitable especially for SMEs frozen meat industries. Since it is portable, it is easier to clean the batch food processing equipment such as mixer, former, and flaker.

Results also showed that high temperature cleaning medium and cleaning chemical is essential in removing the fat-based fouling deposit. The data generated from this work can be used as a guideline to perform cleaning of fat-based fouling deposits in a real factory environment. For future studies, other cleaning parameters, such as the effect of different cleaning times, water pressures, and cleaning chemical concentrations, is recommended. Cleanability experiments using a moving water jet are recommended as well. Preliminary cleaning testing in a laboratory should be done for other types of food-based (protein, carbohydrate,

and mineral) fouling deposits before the cleaning process can be applied in a real environment food factory.

ACKNOWLEDGMENT

The researchers acknowledge the support of Ministry of Science, Technology and Innovation, Malaysia through High Impact Putra Grant (9658400) in conducting this research.

REFERENCES

- [1] N. I. Khalid, N. Nordin, Z. Y. Chia, N. Ab Aziz, A. A. Nuraini, F. S. Taip, and A. Ahmedov, "A removal kinetics approach for evaluation of economic cleaning protocols for pink guava puree fouling deposit," *J. Clean. Prod.*, vol. 135, pp. 1317–1326, 2016.
- [2] H. Köhler, H. Stoye, M. Mauermann, T. Weyrauch, and J. P. Majschak, "How to assess cleaning? Evaluating the cleaning performance of moving impinging jets," *Food Bioprod. Process.*, vol. 93, pp. 327–332, 2015.
- [3] N. Z. Noor Hasnan, N. Ab. Aziz, N. Zulkifli, and F. S. Taip, "Food Factory Design: Reality and Challenges Faced by Malaysian SMEs," *Agric. Agric. Sci. Procedia*, vol. 2, pp. 328–336, 2014.
- [4] M. R. Bird, and S. W. P. Espig, "Cost Optimisation of dairy cleaning in place (CIP) cycles," *Inst. Chem. Eng.*, vol. 72, pp. 17–20, 1994.
- [5] (2020) Cleaning and Disinfection in Food Processing Operations. [Online]. Available: <https://safefood360.com/resources/Cleaning.pdf>.
- [6] W. Liu, P. J. Fryer, Z. Zhang, Q. Zhao, and Y. Liu, "Identification of cohesive and adhesive effects in the cleaning of food fouling deposits," *Innovative Food Science and Emerging Technologies*, vol. 7, pp. 263–269, 2006.
- [7] W. Liu, Z. Zhang, and P. J. Fryer, "Identification and modeling of different removal modes in the cleaning of a model food deposit," *Chemical Engineering Science*, vol. 61, pp. 7528 – 7534, 2006.
- [8] C. R. Gillham, P. J. Fryer, A. P. M. Hasting, and D. I. Wilson, "Cleaning-in-Place of Whey Protein fouling Deposits: Mechanisms Controlling Cleaning. Food and Bioproducts Processing," vol. 77(2), pp. 127–136, 1999.
- [9] C. R. Gillham, P. J. Fryer, A. P. M. Hasting, and D. I. Wilson, "Enhanced cleaning of whey protein soils using pulsed flows," *Journal of Food Engineering*, vol. 46, pp. 199–209, 2000.
- [10] N. I. Khalid, U. S. Saulaiman, N. Ab Aziz, N. A. Nasiruddin, M. M. Hatdran, M. A. Nor Khaizura, N. Z. N. Hasnan, S. Sobri, and F. S. Taip, "Challenges in cleaning for frozen food SMEs: Current and suggested cleaning program." *J. Clean. Prod.*, vol. 235, pp. 688-700, 2019.
- [11] Y. H. Hui, *Sanitation Performance Standards*, 2nd ed., Y. H. Hui, Ed., Handbook of Meat and Meat Processing. Boca Raton, Florida: CRC Press Taylor and Francis Group, 2012.
- [12] J. Piepiorka-Stepuk, J. Diakun, and S. Mierzejewska, "Poly-optimization of cleaning conditions for pipe systems and plate heat exchangers contaminated with hot milk using the Cleaning in Place method," *J. Clean. Prod.*, vol. 112, pp. 946–952, 2016.
- [13] J. M. Vicaria, E. Jurado-Alameda, O. Herrera-Márquez, V. Olivares-Arias, and A. Ávila-Sierra, "Analysis of different protocols for the cleaning of corn starch adhering to stainless steel," *J. Clean. Prod.*, vol. 168, pp. 87–96, 2017.
- [14] A. J. D. Romney, *CIP: Cleaning in Place*. London, UK: Society of Dairy Technology, 1990.
- [15] G. Etienne, *Principles of Cleaning and Sanitation in the Food and Beverage Industry*. USA: iUniverse, 2006.
- [16] A. L. Ho, V. C. Tan, N. Ab. Aziz, F. S. Taip, and M. N. Ibrahim, "Pink Guava Juice Pasteurisation: Fouling Deposit and cleaning studies," *J. - Inst. Eng. Malaysia*, vol. 71, pp. 50–62, 2010.
- [17] H. Y. Law, C. I. Ong, N. Ab. Aziz, F. S. Taip, and N. Muda, "Preliminary Work on Coconut Milk Fouling Deposits Study," *International Journal of Engineering & Technology*, vol. 9, pp. 18–23 2009.
- [18] C. Lelièvre, G. Antonini, C. Faille, and T. Bénézech, "Cleaning-in-Place: Modelling of Cleaning Kinetics of Pipes Soiled by Bacillus Spores Assuming a Process Combining Removal and Deposition," *Food Bioprod. Process.*, vol. 80, pp. 305–311, 2002.
- [19] M. Walton, *Principles of cleaning-in-place (CIP)*, 3rd ed., A. Y. Tamime, Ed., Cleaning in Place: Dairy, Food and Beverages Operation. Oxford, U.K: Blackwell Publishing, 2008.

- [20] T. Wang, J. F. Davidson, and D. I. Wilson, "Flow patterns and cleaning behaviour of horizontal liquid jets impinging on angled walls," *Food Bioprod. Process.*, vol. 93, pp. 333–342, 2015.
- [21] M. C. Leu, P. Meng, E. S. Geskin, and L. Tismeneskiy, "Mathematical Modeling and Experimental Verification of Stationary Waterjet Cleaning Process," *J. Manuf. Sci. Eng.*, vol. 120, pp. 571–579, 1998.
- [22] P. Meng, E. S. Geskin, M. C. Leu, and L. Tismeneskiy, "An Analytical and Experimental Study of Cleaning with Moving Waterjets," *J. Manuf. Sci. Eng.*, vol. 120, pp. 580–589, 1998.
- [23] T. Bénézech, C. Lelièvre, J. M. Membré, A.-F. Viet, and C. Faille, "A new test method for in-place cleanability of food processing equipment," *J. Food Eng.*, vol. 54, pp. 7–15, 2002.
- [24] N. I. Khalid, N. Nordin, A. A. Nuraini, N. Ab. Aziz, F. S., Taip, and M. S. Anuar, "Design of a Test Rig for Cleaning Studies and Evaluation of Laboratory-Scale Experiments Using Pink Guava Puree as a Fouling Deposit Model," *J. Food Process Eng.*, vol. 38, pp. 583–593, 2015.
- [25] C. Lelievre, C. Faille, and T. Benezech, "Removal Kinetics of Bacillus Cereus Spores from Stainless Steel Pipes Under Cip Procedure: Influence of Soiling and Cleaning Conditions," *J. Food Process Eng.*, vol. 24, pp. 359–379, 2001.
- [26] M.R. Luo, "The quality of light sources," *Coloration Technology*, vol. 127, pp. 75–87, 2011.
- [27] N. I. Khalid, N. Ab Aziz, A. A. Nuraini, F. S. Taip, and M. S. Anuar, "Alkaline Cleaning-in-Place of Pink Guava Puree Fouling Deposit Using Lab-scale Cleaning Test Rig," *Agric. Agric. Sci. Procedia*, vol. 2, pp. 280–288, 2014.
- [28] W. J. Watkinson, *Chemistry of Detergents and Disinfectants*, 3rd ed., A. Y. Tamime, Ed., Cleaning in Place: Dairy, Food and Beverages Operation. Oxford, U.K: Blackwell Publishing, 2008.
- [29] M. C. Leu, P. Meng, E. S. Geskin, and L. Tismeneskiy, "Mathematical Modeling and Experimental Verification of Stationary Waterjet Cleaning Process," *J. Manuf. Sci. Eng.*, vol. 120, pp. 571–579, 1998.
- [30] P. Meng, E. S. Geskin, M. C. Leu, and L. Tismeneskiy, "An Analytical and Experimental Study of Cleaning with Moving Waterjets," *J. Manuf. Sci. Eng.*, vol. 120, pp. 580–589, 1998.
- [31] H. Köhler, H. Stoye, M. Mauermann, and J. Majschak, "Optimization approach for efficient cleaning with impinging jets – Influence of nozzle diameter, pressure and nozzle distance," in Proc. of International Conference on Heat Exchanger Fouling and Cleaning 2013, 2013, pp. 421–428.
- [32] M. Stanga, *Sanitation: Cleaning and Disinfection in the Food Industry*, 1st ed. Weinheim, Germany: Wiley-VCH, 2010.