

# Development And In Vivo Evaluation Of Immediate Release Amlodipine Besylate And Nebivolol Hydrochloride Coated Pellets Using 3<sup>2</sup> Full Factorial Design By Novel Liquid Layering Technology

Y. Roopa Rani<sup>1</sup>, P.Vijayalakshmi<sup>2</sup>, J. Venkateswara Rao<sup>3</sup>

## \*Corresponding author:

Y. Roopa Rani

<sup>1</sup>Sultan-Ul-uloom College of Pharmacy,  
Banjara hills, Hyderabad, A.P, 500082.

<sup>2</sup>Sree Dattha Institute of Pharmacy,  
Sheriguda, Ibrahimpatnam, Hyderabad,  
A.P, 500004

<sup>3</sup>Bharat Institute of Pharmacy,  
Mangalpally, Ibrahimpatnam,  
Hyderabad, A.P, 501510.

## Abstract

The aim of the present investigation was to development of immediate release liquid coated pellets of poorly soluble drugs Amlodipine besylate (AMD) and Nebivolol HCl (NBV) by novel liquid layering technology to enhance solubility and bioavailability with HPC-EF as hydrophilic polymer and PVP K 30 as binder.

A 3<sup>2</sup> full factorial design was employed to optimize the formulation of pellets. In order to optimize formulations, two polymers HPC-EF and PVP K 30 as factors and amount of polymers (three different concentrations), were taken as independent variables. All the formulations were evaluated for particle size, friability, moisture content, drug content, in vitro dissolution studies and in vivo bioavailability studies.

All the formulations were found uniform with respect to all evaluation parameters. The optimized formulation (F5) showed highest % of drug release 99.59 by the end of 8 min for AMD and 99.21 % of drug release for NBV, when compared with the marketed product (NEBISTAR-AM) the percentage of AMD and NBV was 83.91 and 82.67 respectively within 8 min, by using 4% of HPC-EF and 1% of PVP K 30. SEM confirmed that F5 was spherical in shape with a smooth surface.

*In vivo* studies indicated significant difference in the bioavailability between AMD and NBV coated pellets with pure drug. Clinical data confirmed that the optimized formulation (F5) by choosing immediate release drug coated pellet technology by liquid layering method could improve patient compliance and ensure better disease management when compared with the marketed product.

**Keywords:** Amlodipine besylate, Nebivolol HCl, pellets, liquid layering technique, bioavailability studies.

## Introduction

With the advances in pharmaceutical research, there are thousands of new compounds getting synthesized every year and out of these, 40% show solubility problem which further makes their processing difficult. Poor aqueous solubility not only produces irreproducible therapeutic response but also leads to the wastage of large amount of drugs [1, 2].

These molecules are difficult to formulate using conventional approaches and are associated with innumerable formulation-related performance issues [3]. Multiparticulate dosage forms are receiving an immense attention as alternative drug delivery systems for oral drug delivery even though single-unit dosage forms have been widely used for decades [4]. Pellets are agglomerates of fine powders or granules of bulk drugs and excipients [5]. Pellets have free flowing properties and low porosity of about 10% [6]. Experimental designs have long been employed to optimize various industrial products and/or processes such as the factorial designs (FDs) since 1926 [7]. Amlodipine besylate is a calcium channel blocker can reduces blood pressure by dilate

blood vessel leads to reduction of cardiac output and slowing heart rate [8]. Nebivolol is a long acting, cardio selective beta blockers, currently licensed for the treatment of hypertension [9]. The aim of the present investigation was to develop a multiparticulate dosage form containing amlodipine besylate and nebivolol hydrochloride drug layered pellets with the objective of enhancing the solubility and bioavailability of the drug by using liquid layering technology.

## Materials and Methods

Nebistar-AM (2.5mg Amlodipine besylate & Nebivolol HCl 5mg) was purchased from Lupin Pharma, Mumbai. Amlodipine besylate and Nebivolol hydrochloride was gifted by Aurobindo pharma limited, Hyderabad, India. PVP K 30, Hydroxy Propyl Cellulose HPC-EF and MCC were obtained from MSN laboratories, Hyderabad. All other polymers and solvents used were of analytical grade.

## Procedure for the preparation of core pellets



## Preparation of core pellets

Weighed accurately 44g of MCC and pass through #30/#40 mesh, to this add binder solution prepared by taking 0.05 g of PVP K 30 dissolved in water and mixed thoroughly. The sugar solution is sprayed on to the prepared beads, dried the pellets at 45<sup>o</sup> and again passed through the sieve #20 mesh and used for seal coating.

## Coating of polymer solution

Weighed 50g of core pellets and different concentrations of polymeric solution of HPC-EF (3%, 4%, 5%) was sprayed on to the core pellets by maintain the coating pan rotating at a speed of

45rpm and hot air (70°C) is passed simultaneously through the pan to dry the coated pellets.

## Coating of drug solution on to sub-coated pellets

Prepared different concentrations of PVP K 30 by dissolving 0.5g, 1g, 1.5g of PVP K 30 in water and added to the beaker containing drugs Amlodipine besylate and Nebivolol HCl with methanol. The prepared solution was sprayed on to the sub coated pellets through spray gun at a rate of a 2ml/min, maintain the coating pan speed of 45 rpm and follow the process as mentioned in coating of polymer solution. The compositions of Amlodipine & Nebivolol solution with polymers coated on core pellets are summarized in Table 1.

**Table 1: Composition of Amlodipine & Nebivolol solution with polymers coated on core pellets**

S.NO	FORMU-LATION	CORE PELLETS (g)	AMLODIPINE BESYLATE (g)	NEBIVOLOL HYDRO-CHLORIDE(g)	HPC-EF (g)	PVP K30 (g)	METHANOL (ml)
1	F1	50	1.25	2.5	2.5	0.5	20
2	F2	50	1.25	2.5	2.5	1.5	20
3	F3	50	1.25	2.5	1.5	1.5	20
4	F4	50	1.25	2.5	2	1.5	20
5	F5	50	1.25	2.5	2	0.5	20
6	F6	50	1.25	2.5	1.5	0.5	20
7	F7	50	1.25	2.5	2.5	1	20
8	F8	50	1.25	2.5	2	1	20
9	F9	50	1.25	2.5	2	1	20
10	F10	50	1.25	2.5	1.5	1	20

## Experimental design and statistical analysis

In this study, a 3<sup>2</sup> full factorial design was employed to optimize the formulation of pellets. In order to optimize formulations, two polymers HPC EF and PVP K 30 as factors and amount of polymers (three different concentrations), were taken as independent variables. HPC-EF, being hydrophilic is more permeable to water so it promotes release of drug. PVP K 30 is also hydrophilic and acts as a binder and viscosity enhancer. Selection of response variables was crucial. The target was to obtain the drug release immediately, but simultaneously to achieve the maximum release. Therefore the response variables selected for evaluation of immediate release were percent of drug release within 2min and 8min was selected as dependent variables. The data obtained by experimental design was processed using Design expert 9.0.1.0 software. 3-D response surface curves were constructed to study the effect of three independent variables alone and in combination of percent drug release at 2min and 8min. All the responses observed were simultaneously fitted to quadratic models and were evaluated in terms of statistical parameters.

## Evaluation parameters

### Particle size analysis

The particle size of the pellets was measured by using projected area diameter. It is the diameter of a circle having the same area as the particle viewed normally to the plane surface on which the particle is at rest in a stable position [10].

### Friability

Roche friability tester (Electrolab friability tester, EF-2, India) was used to determine the friability. Pre-weighed pellets were placed in friabilator and rotated at a speed of 25rpm for 4 min. The friability was calculated using the following equation [11].

Friability (%) =  $\frac{[1 - \text{initial weight} / \text{weight retained after 100 rotations}] \times 100}{100}$

### Moisture content

1g of pellets were weighed and kept in oven at 40°C. Its weight was noted as initial weight (W1). They were removed from the oven after regular intervals of 15min and weighed. Loss in weight of pellets was noted. After attaining constant weight, it was noted as final weight (W2) and percent moisture content was calculated [12].

### Drug content

115mg of drug layered pellets was taken and crushed to a fine powder. The powdered material was transferred in to a 100 ml



volumetric flask and pH 1.2 HCl buffer was added to it. It was continuously stirred for 2 hrs. About 10 ml of the solution was taken from the volumetric flask and centrifuged. The solution from the centrifuge tube was filtered by using Millipore filter. Then the filtrate was subsequently diluted and the absorbance was measured at 238nm and 280nm for Amlodipine besylate and Nebivolol HCl respectively [13].

### In vitro drug release studies

Pellets equivalent to 2.5mg Amlodipine besylate and 5mg Nebivolol hydrochloride were weighed and placed in 900 ml of dissolution media (pH-1.2 HCl buffer) containing in USP dissolution apparatus II and stirred at a speed of 75 rpm at  $37 \pm 0.5^\circ\text{C}$ . 5ml of aliquots were withdrawn at 1, 2, 4, 6, 8 min and replaced by 5 ml of fresh dissolution media. The collected samples are measured at three wavelengths such as 238nm, 268nm (Iso-absorptive point) and 280nm. The amount of drug released was calculated from the calibration curve of the same dissolution medium.

### Scanning Electron Microscopy (SEM)

The surface and shape characteristics of pellets were determined by scanning electron microscopy (SEM). Photographs were taken and recorded at suitable magnification.

### Stability studies

The stability study of the formulated drug layered pellets was carried out under different conditions according to ICH guidelines. The drug layered pellets were stored in a stability chamber for stability studies. Accelerated Stability studies were carried out at  $40^\circ\text{C} / 75\% \text{ RH}$  for the best formulations for 3 months. The drug layered pellets were characterized for the drug content and other parameters during the stability study period [14].

### In vivo studie

#### Animal Preparation

Eighteen healthy male rats were selected for this study, all the animals were healthy during the period of the experiment. All efforts were made to maintain the animals under controlled environmental conditions (Temperature  $25^\circ\text{C}$ , Relative Humidity 45% and 12 h alternate light and dark cycle] with 100 % fresh air exchange in animal rooms, uninterrupted power and water supply and rats were fed with standard diet and water ad libitum. The protocol of animal study was approved by the institutional animal ethics committee (IAEC NO: IAEC / SUCP/07/2013). The rats were fasted overnight before administration of the formulation (Amlodipine Besylate, Nebivolol Hydrochloride coated pellets) and pure drug (Amlodipine Besylate, Nebivolol Hydrochloride). The rats were randomly divided into two groups each group contains six animals. The group A rats were received prepared Amlodipine Besylate, Nebivolol Hydrochloride coated pellets, group B received

pure drug Amlodipine Besylate, and group C received Nebivolol Hydrochloride pure drug administered orally.

Blood samples for pharmacokinetic analysis were obtained at different time intervals 0, 15, 30, 60, 120, 240, 360 min and 24hrs after dosing. Blood samples were collected in heparinized tubes and were centrifuged for 10min at 3,000 rpm at room temperature [15].

### Preparation of Plasma Samples for HPLC Analysis

Rat plasma (0.5 ml) was prepared for chromatography by precipitating proteins with 2.5 ml of ice-cold absolute ethanol for each 0.5 ml of plasma. After centrifugation the ethanol was transferred into a clean tube. The precipitate was resuspended with 1 ml of acetonitrile by vortexing for 1 min. After centrifugation (5000 – 6000 rpm for 10 min), the acetonitrile was added to the ethanol and the organic mixture was taken to near dryness by a steam of nitrogen at room temperature. Samples were reconstituted in 200  $\mu\text{l}$  of Mobile phase was injected for HPLC analysis. Hydrochlorothiazide was added as internal standard. The chromatographic conditions were shown in Table 2.

**Table 2: Chromatographic conditions**

Column	C18
Mobile Phase	Acetonitrile : Phosphate buffer ( $\text{P}^{\text{H}}$ 3.0) (40:60)
Flow rate	0.8ml/min
Injection volume	20 $\mu\text{l}$
Retention times	Hydrochlorothiazide (Internal standard) - 2.643 Amlodipine besylate - 6.393, Nebivolol HCl -11.342

## Results and Discussion

### Evaluation Parameters

#### Particle size analysis

Each pellet size was measured by using electron microscope and found to be 735-770  $\mu\text{m}$ .

The drug layered pellets were also evaluated for friability and moisture content, which found to be within the Indian Pharmacopoeal limits.

#### Drug content

All the formulations of Amlodipine besylate and Nebivolol HCl coated pellets were found to contain an almost uniform quantity of the drug, as per content uniformity studies indicating reproducibility of the technique. Drug content in the all formulations were evaluated and the values of Amlodipine besylate and Nebivolol HCl were found to be between  $98.58 \pm 0.15$  to  $99.82 \pm 0.55$  &  $98.34 \pm 0.52$  to  $99.67 \pm 0.52$  respectively. As per the USP requirements, the formulations were found to meet the criteria for content uniformity, results are depicted in Table

4.



**Table 4: % Drug content of Amlodipine besylate and Nebivolol hydrochloride coated pellets**

FORMULATION CODE	AMLODIPINE BESYLATE	NEBIVOLOL HYDROCHLORIDE
F1	99.54 ± 0.25	98.92 ± 0.31
F2	98.91 ± 0.64	99.27 ± 0.39
F3	98.58 ± 0.15	98.69 ± 0.53
F4	99.72 ± 0.52	98.73 ± 0.39
F5	99.16 ± 0.34	99.67 ± 0.52
F6	99.60 ± 0.39	98.82 ± 0.47
F7	99.53 ± 0.46	98.80 ± 0.39
F8	99.82 ± 0.55	99.10 ± 0.43
F9	99.29 ± 0.43	98.34 ± 0.52
F10	99.04 ± 0.41	98.86 ± 0.48

**In vitro drug release studies**

The % drug release of Amlodipine besylate from formulations F1 to F10 are within the range of 77.49 ± 0.48 to 99.59 ± 0.40 at the end of 8 min. Rapid drug dissolution was observed in F5 as 99.59. The % drug release of Nebivolol HCl from formulations F1 to F10 are within the range of 77.49 ± 0.48 to 99.21 ± 0.29 at the end of 8 min. Rapid drug dissolution was observed in F5 as 99.21. The optimized formulation (F5) shows highest percent of drug release 99.59 by the end of 8 min for Amlodipine besylate (Table 5) (Figure 1) and 99.21 % of drug release for Nebivolol HCl (Table 6) (Figure 3), when compared with the marketed product (NEBISTAR-AM) the % of Amlodipine besylate (Figure 2) and Nebivolol HCl (Figure 4) was 83.91 ± 0.21 and 82.67 ± 0.26 respectively within 8 min.

**Table 5: Cumulative % drug release of pellets coated with Amlodipine besylate**

FORMULATION CODE	0 min	1min	2min	4min	6min	8min
F1	0	60.24 ± 0.29	80.61 ± 0.57	83.27 ± 0.34	86.59 ± 0.46	92.21 ± 0.42
F2	0	56.24 ± 0.54	75.85 ± 0.51	78.51 ± 0.43	81.37 ± 0.46	88.16 ± 0.38
F3	0	49.61 ± 0.18	65.58 ± 0.28	68.71 ± 0.43	70.58 ± 0.38	72.19 ± 0.25
F4	0	69.51 ± 0.27	83.91 ± 0.29	87.12 ± 0.42	91.37 ± 0.31	95.36 ± 0.27
F5	0	71.52 ± 0.39	85.92 ± 0.41	93.17 ± 0.60	96.51 ± 0.27	99.59 ± 0.40
F6	0	53.27 ± 0.61	69.37 ± 0.28	72.12 ± 0.57	75.13 ± 0.19	80.40 ± 0.35
F7	0	61.19 ± 0.31	78.17 ± 0.72	80.56 ± 0.51	83.12 ± 0.38	86.26 ± 0.39
F8	0	70.01 ± 0.47	83.97 ± 0.61	92.09 ± 0.43	95.53 ± 0.41	97.85 ± 0.31
F9	0	69.51 ± 0.29	83.62 ± 0.61	91.13 ± 0.43	94.83 ± 0.41	97.03 ± 0.31
F10	0	51.57 ± 0.49	68.10 ± 0.38	70.15 ± 0.37	73.29 ± 0.58	78.58 ± 0.42
NEBISTAR-AM	0	62.72 ± 0.34	68.92 ± 0.24	74.10 ± 0.17	78.26 ± 0.27	83.91 ± 0.21

**Table 6: Cumulative % drug release of pellets coated with Nebivolol hydrochloride**

FORMULATION	0 min	1min	2min	4min	6min	8min
F1	0	72.74 ± 0.27	80.04 ± 0.49	83.91 ± 0.37	86.54 ± 0.54	92.05 ± 0.49
F2	0	67.51 ± 0.34	74.12 ± 0.37	78.91 ± 0.49	81.57 ± 0.74	88.13 ± 0.49
F3	0	59.10 ± 0.48	65.09 ± 0.51	68.19 ± 0.27	70.01 ± 0.38	71.91 ± 0.54
F4	0	76.91 ± 0.17	81.12 ± 0.43	86.59 ± 0.61	91.02 ± 0.27	95.91 ± 0.37
F5	0	71.82 ± 0.32	85.19 ± 0.72	93.88 ± 0.31	96.06 ± 0.67	99.21 ± 0.29
F6	0	60.87 ± 0.61	68.74 ± 0.29	71.67 ± 0.38	74.91 ± 0.56	80.01 ± 0.37
F7	0	69.69 ± 0.11	78.05 ± 0.51	81.62 ± 0.49	83.71 ± 0.28	89.41 ± 0.34
F8	0	79.57 ± 0.17	83.91 ± 0.46	90.69 ± 0.27	94.53 ± 0.51	97.21 ± 0.24
F9	0	79.11 ± 0.39	83.24 ± 0.46	90.69 ± 0.27	94.53 ± 0.51	96.72 ± 0.24
F10	0	60.97 ± 0.29	67.72 ± 0.72	69.79 ± 0.61	72.19 ± 0.37	77.49 ± 0.48
NEBISTAR-AM	0	62.72 ± 0.34	68.15 ± 0.24	73.49 ± 0.18	77.09 ± 0.21	82.67 ± 0.26



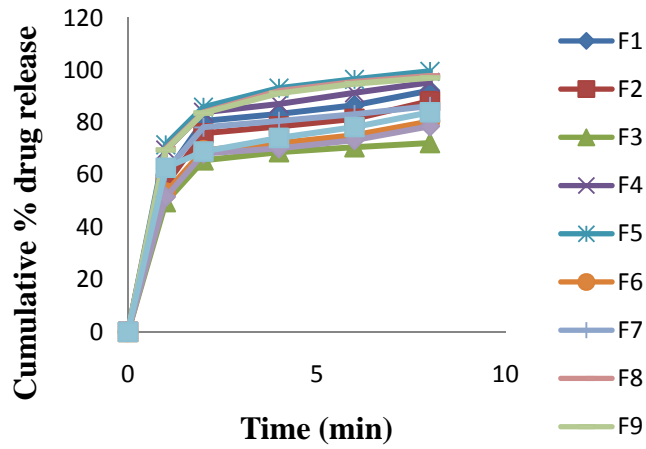

Figure 1: In-vitro release of amlodipine besylate in coated pellets and marketed product.

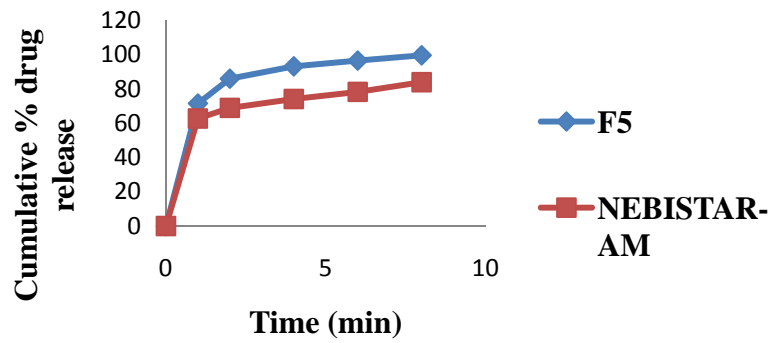

Figure 2: Comparison of cumulative % drug release of Amlodipine besylate of prepared formulation (F5) with marketed product NEBISTAR-AM

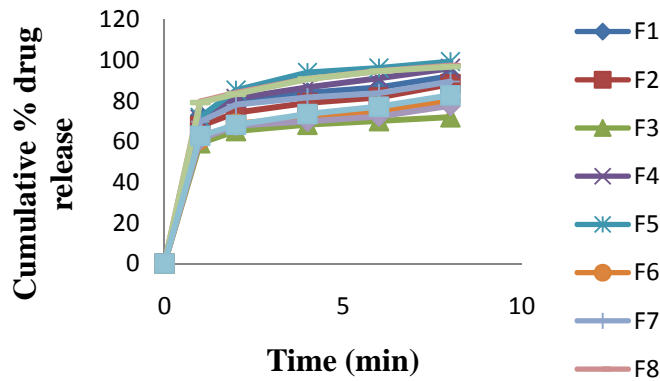

Figure 3: In-vitro release of Nebivolol hydrochloride in coated pellets and marketed Product

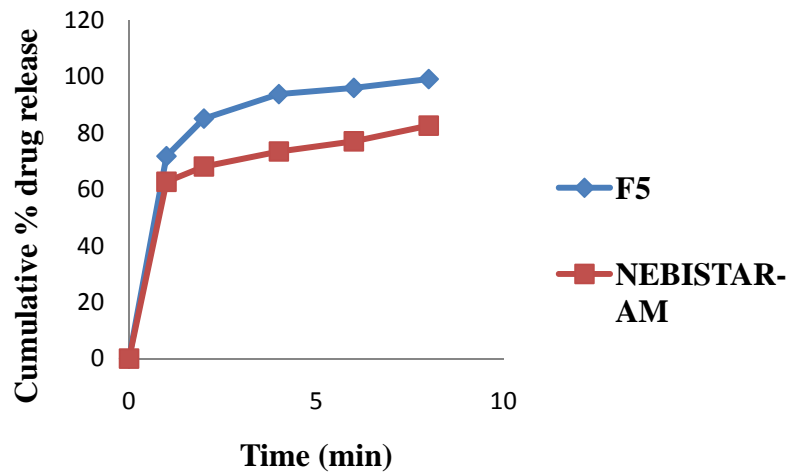

Figure 4: Comparison of cumulative % drug release of Nebivolol hydrochloride of prepared formulation (F5) with marketed product NEBISTAR-AM

### Scanning Electron Microscopy

The Amlodipine & Nebivolol HCl coated optimized pellet formulation (F5) was characterized by SEM analysis to understand the pellet shape and surface morphology (Figure 15 & 16). The

pellets prepared were having spherical in shape and smooth surface with minimal pores, indicating the uniform coating of the pellets.

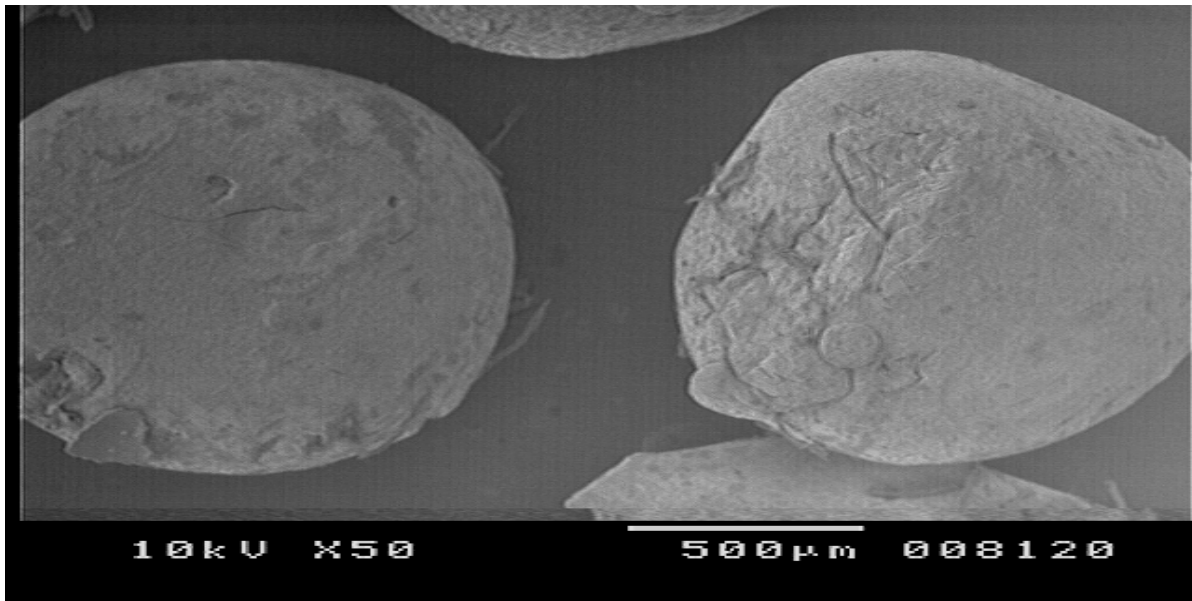

Figure 5: SEM images of Amlodipine &amp; Nebivolol HCl coated pellets



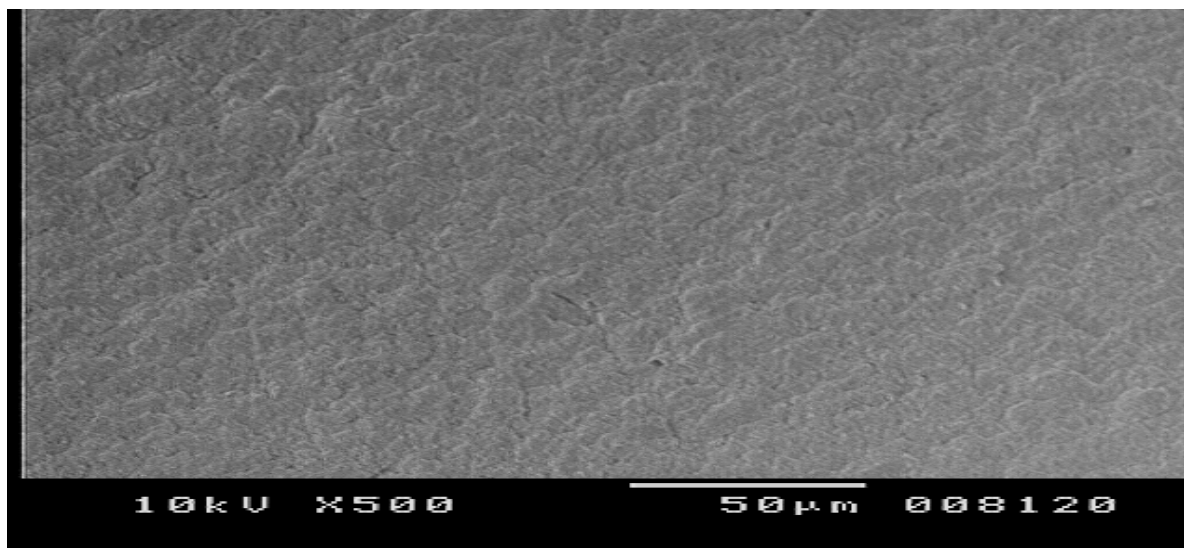

Figure 6: SEM images of Amlodipine & Nebivolol HCl coated pellets

### Stability Studies for Amlodipine & Nebivolol HCl coated optimized pellet formulation (F5)

F5 formulation was selected for stability studies on the basis of excellent % drug content & high cumulative % drug release of Amlodipine & Nebivolol HCl from pellets. Stability studies were

conducted under accelerated conditions according to ICH guidelines using Remi stability chambers, Mumbai. From these results it was concluded that, formulation F5 was stable and retained their original properties with minor differences (Table 7).

Table 7: Accelerated stability testing data of optimized formulation (F5) at 40 °C/75 %RH

Retest Time For F5	Percent Drug Content/ Assay for Amlodipine besylate (%)	Cumulative % drug release for Amlodipine besylate	Percent Drug Content/ Assay for Nebivolol HCl (%)	Cumulative % drug release for Nebivolol HCl
1 Week	99.15	99.45	99.65	99.00
2 Weeks	98.85	98.55	98.95	98.45
1 Month	98.22	98.32	98.42	98.12
2 Months	98.05	98.00	98.15	97.80
3 Months	97.60	97.30	97.50	97.20

### Experimental design and statistical analysis

The experiments were designed to study effect of two independent variables at three levels on response variables such as percent drug release at 2min and 8min. The counter plot will help in understanding of the design space. In all the above counter plots the design space is available in the red color region which is indicated in the plot as shaded region from 3.5-4.75% of HPC-EF concentration, so this is the space we should focus on, to obtain the formulation with accurate results. The immediate release of amlodipine besylate and nebivolol hydrochloride was observed at the 4% concentration of HPC-EF and 1% of PVP K 30.

### Statistical models

For % release response, F-value, P-value, R Square and adequate precision of amlodipine besylate and nebivolol at 2min and 8min were shown in Table 8 & 9. From F-values & P-values, the model is significant. Adequate precision shows signal to noise ratio. The ratio of amlodipine besylate and nebivolol hydrochloride indicates an adequate signal, thus the proposed model can be used to navigate the design space.

Table 8: ANOVA of dependant variables for Amlodipine besylate

Response model	F value	P value	R Square	Adequate Precision
2min	1654.20	<0.0001	0.9995	104.95
8min	181.32	<0.0001	0.9956	37.468



**Table 9: ANOVA of dependant variables for Nebivolol HCl**

Response model	F value	P value	R Square	Adequate Precision
2min	2068.83	<0.0001	0.9996	117.85
8min	131.83	<0.0001	0.9940	31.787

### Response surface analysis

A substantial high drug release is achieved in F5 formulation which is very much faster than the marketed product (Nebistar-AM). The statistical analysis of the factorial design batches was performed by multiple linear regression analysis. The  $t_2$ ,  $t_8$  values for the 10 batches showed a wide variation. The values of the correlation coefficient indicate a good fit. The polynomial equation can be used to draw conclusions after considering the magnitude of coefficient and the mathematical sign it carries, (i.e. positive or negative).

From figure 17 the plots were found to be linear for 70%, 75%, 80% and 85% dissolution rate which is found between 3-3.75% of polymer concentration, but there is a non linearity for 90% around 4% concentration of polymer in figure 17 and figure 19 for Amlodipine besylate. In figure 18 and figure 20 at 80% and 90% the linear nature is observed, the plot shows nonlinear nature at 100% dissolution rates.

Response surface plots are very helpful in learning about both the main and interaction effects of the independent variables. From

the above 3D-surface graphs, the observation noted is that the, release of drug increased to a great extent when the concentration of polymer is increased from 3% to 4% for Amlodipine besylate (figure 21 and figure 23) and for Nebivolol hydrochloride (figure 22 and figure 24) but very minor effect of PVP K 30 is observed in the release profile of drug, because even the PVP K 30 concentration is increased the residual surface towards the factor B is altered to a little extent at the end of 8min, but this is not showing a remarkable difference. So from the above plot we can confirm that the release of drug at 8min is also due to the HPC-EF polymer only. The amlodipine besylate and nebivolol hydrochloride released into the fluid is mainly depending on the variation in the polymer concentration but not on the variation in binder concentration.

The F5 formulation is checked for its drug release in 6 trials and each trial is performed for 3 times to avoid the variance in the release profile of the drug. The variance is very less as 0.0157 and the critical F value (2.2718) is greater than calculated F value (1.2336) for amlodipine besylate and the variance for nebivolol hydrochloride is 0.0235 and the critical F value (2.2724) is greater than calculated F value (1.1145), which says that the repeatability of the release of the drug is high. The critical F value is greater than the calculated F value, so it is confirmed that the F5 formulation is selected as the best formulation among the ten prepared formulations.

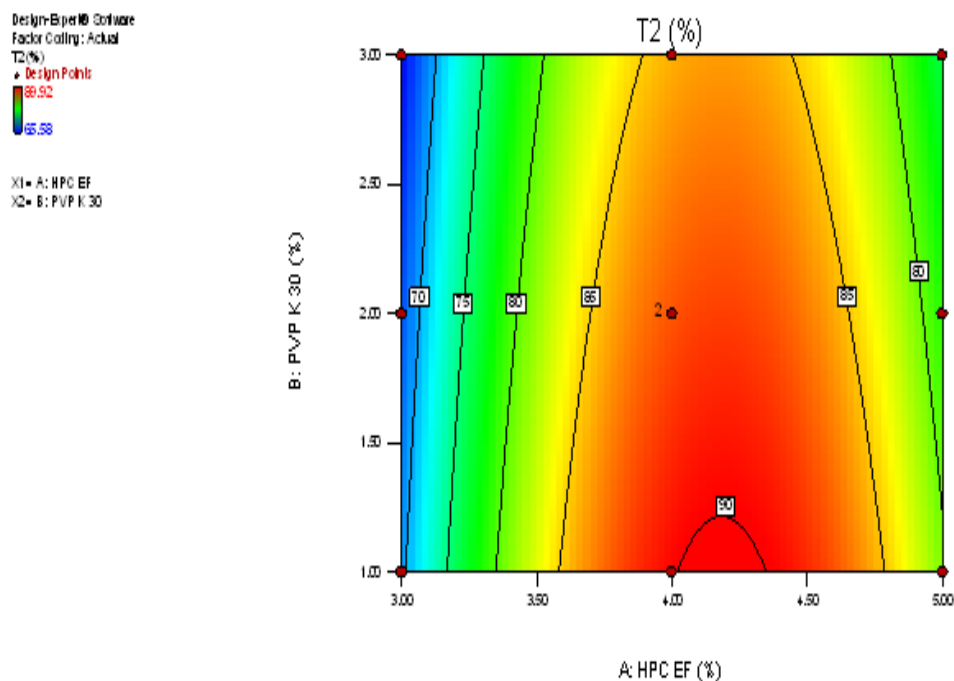

**Figure 7: Counter plot showing the influence of amount of polymer and amount of binder on the release profile of Amlodipine besylate after 2min**



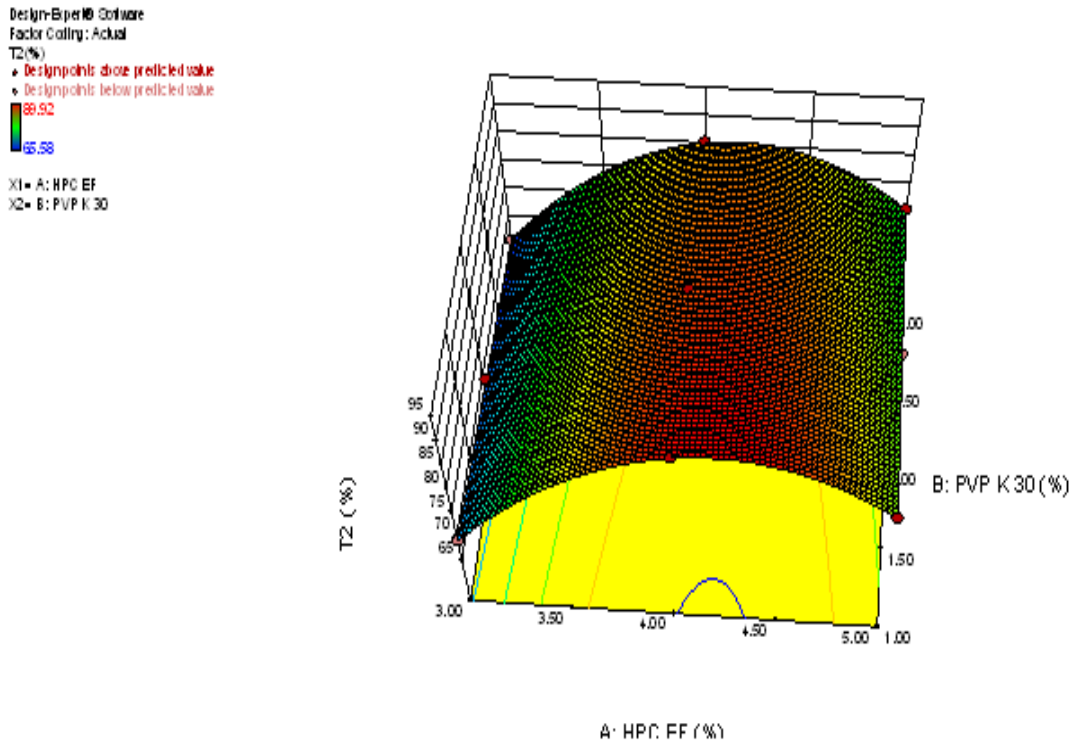

Figure 8: Response surface plot showing the influence of amount of polymer and amount of binder on the release profile of Amlodipine besylate after 2min

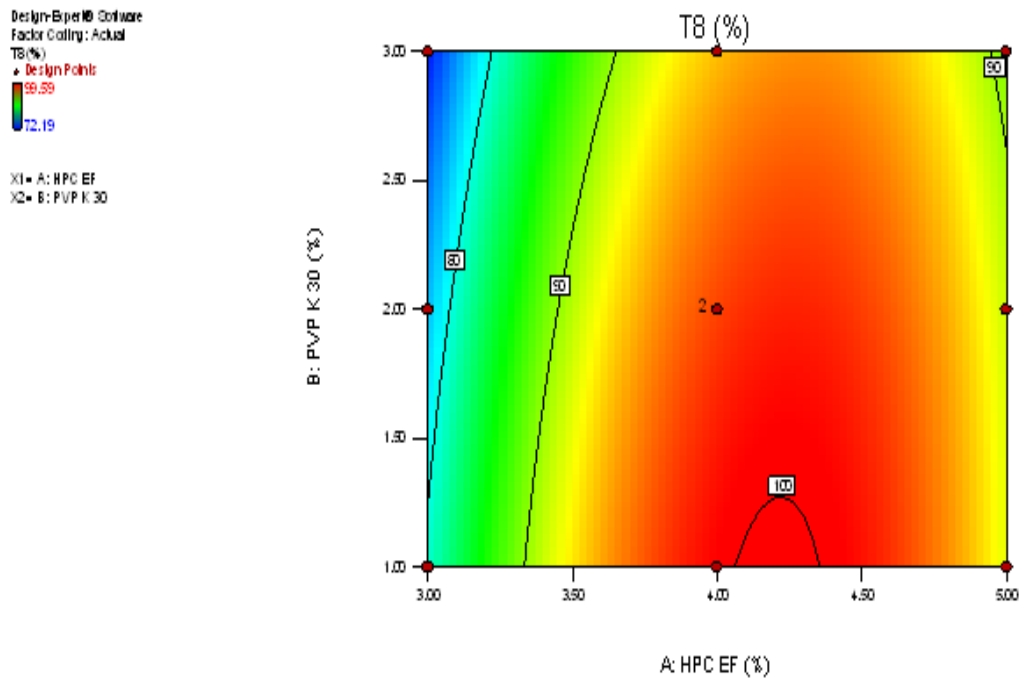

Figure 9: Counter plot showing the influence of amount of polymer and amount of binder on the release profile of Amlodipine besylate after 8min



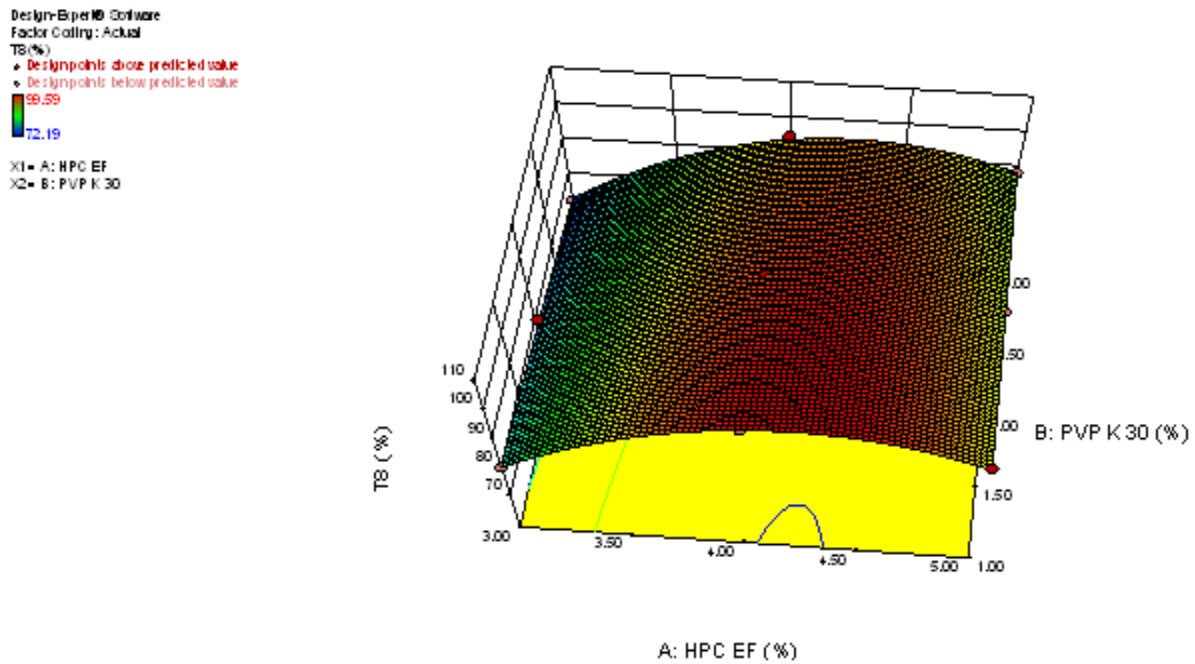

Figure 10: Response surface plot showing the influence of amount of polymer and amount of binder on the release profile of Amlodipine besylate after 8min

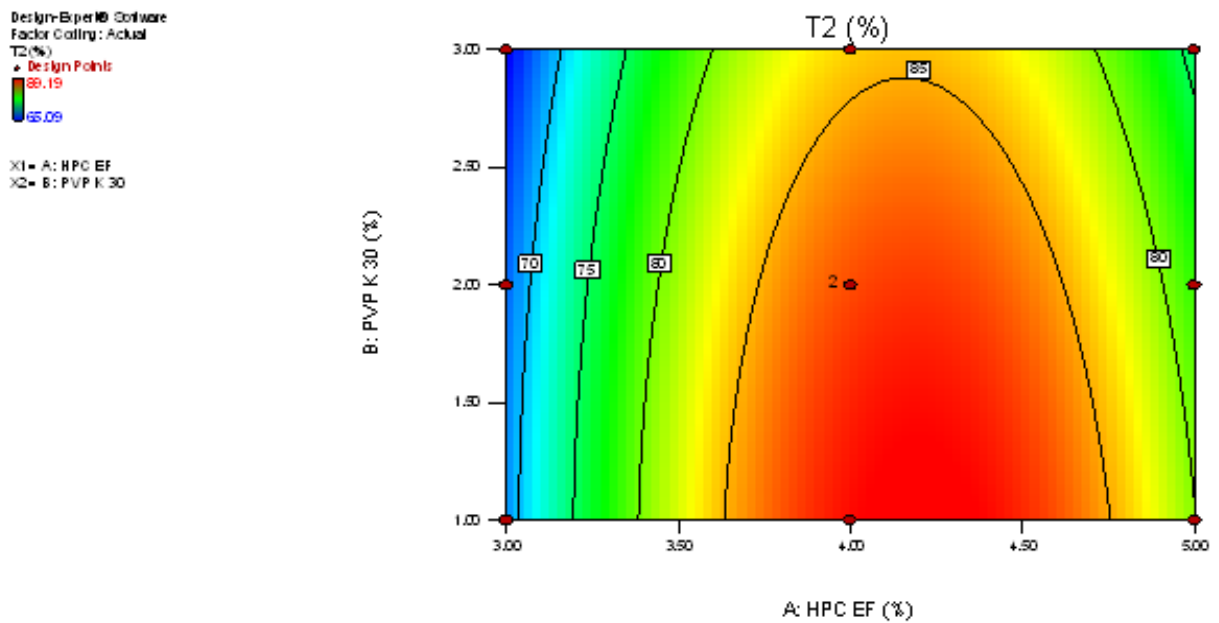

Figure 11: Counter plot showing the influence of amount of polymer and amount of binder on the release profile of Nebivolol hydrochloride after 2min



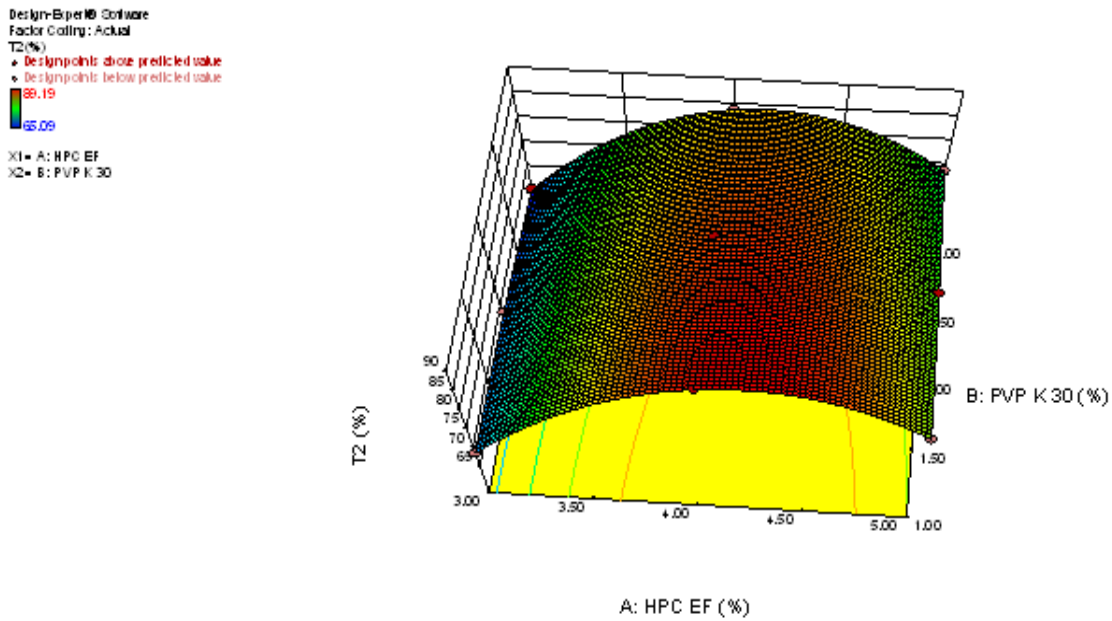

Figure 12: Response surface plot showing the influence of amount of polymer and amount of binder on the release profile of Nebivolol hydrochloride after 2min

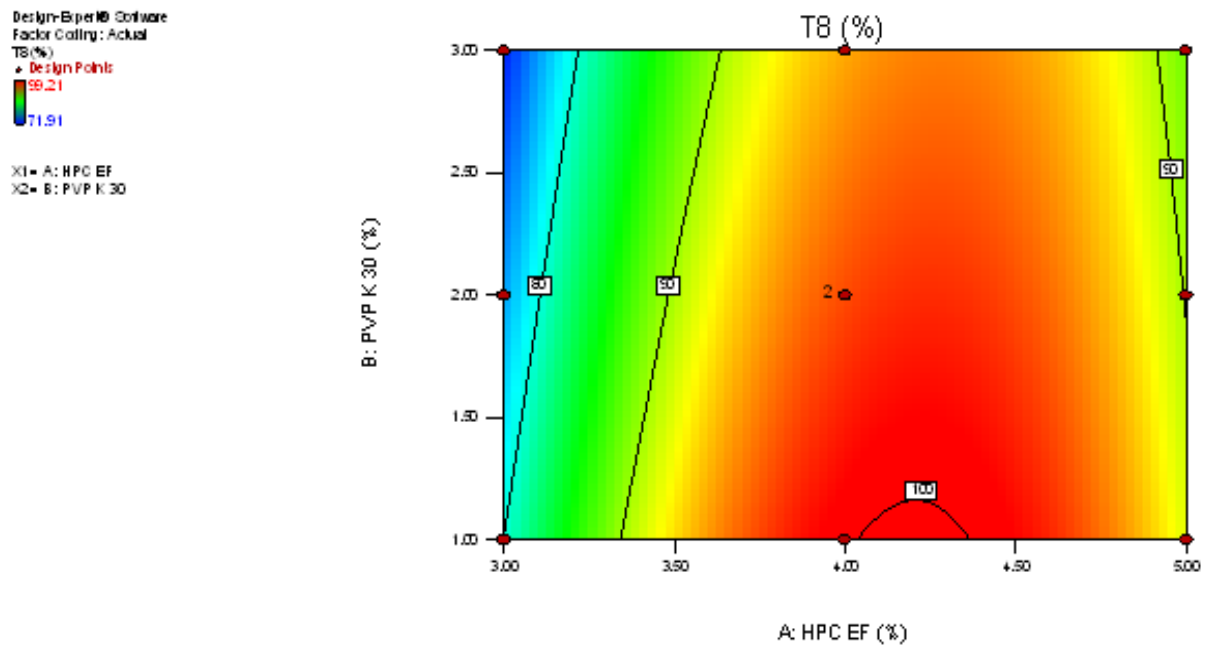

Figure 13: Counter plot showing the influence of amount of polymer and amount of binder on the release profile of Nebivolol hydrochloride after 8min



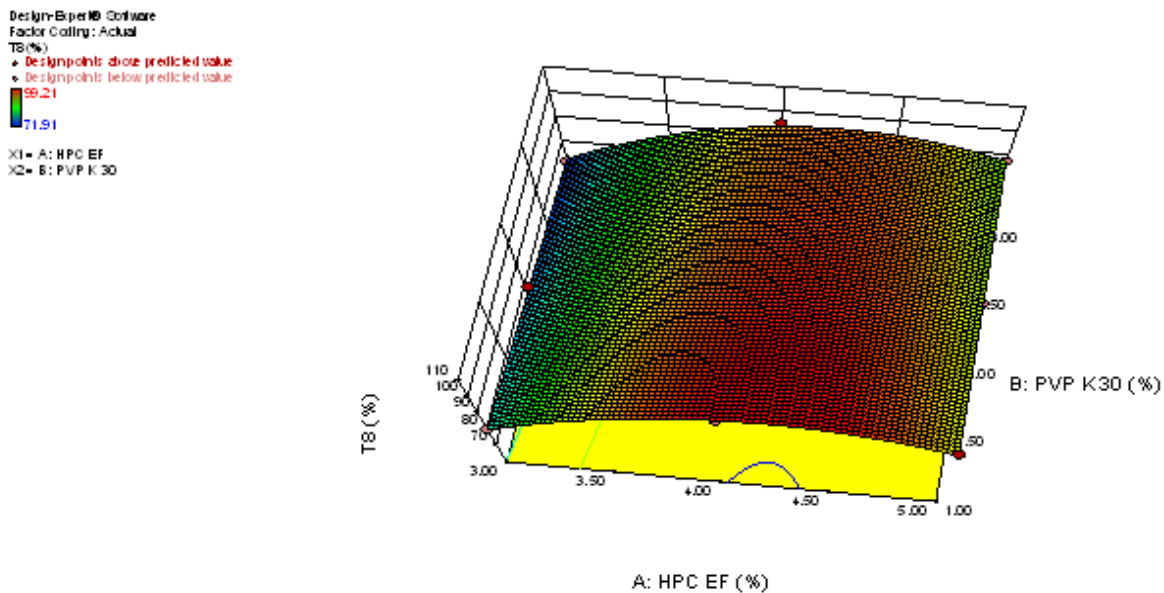

Figure 14: Response surface plot showing the influence of amount of polymer and amount of binder on the release profile of Nebivolol hydrochloride after 8min

*In vivo* studies

Bioavailability Parameters

Pharmacokinetic studies were carried out for test formulation (F5) (coated with AMD and NBV) and pure drugs, where results are shown in Table 13 for AMD and Table 14 for NBV. The  $C_{max}$  and  $T_{max}$  for test formulation for AMD and Amlodipine pure drug was found to be  $1050 \pm 24 \mu\text{g/ml}$ ,  $15 \pm 22\text{h}$  and  $950 \pm 32 \mu\text{g/ml}$  and  $30 \pm 15\text{h}$  respectively. In order to estimate the amount of drug absorbed from the test formulation, the relative bioavailability was calculated from the AUC of the pure drug and test formulation ( $17006 \pm 045 \mu\text{g.hr/ml}$  and  $18789 \pm 735 \mu\text{g.hr/ml}$ ). The above results indicated that the bioavailability of the test formulation was increased significantly compare with pure drug. The  $t_{1/2}$  for optimized test formulation and pure drug was  $1.005 \pm 0.142\text{h}$  and  $1.263 \pm 0.213\text{h}$ , respectively. The  $C_{max}$  and  $T_{max}$  for test formulation for NBV and Nebivolol pure drug was found to be  $2152 \pm 125 \mu\text{g/ml}$ ,  $15 \pm 42\text{h}$  and  $2001 \pm 243 \mu\text{g/ml}$  and  $30 \pm 35\text{h}$  respectively. In order to estimate the amount of drug absorbed from the test formulation, the relative bioavailability was calculated from the AUC of the pure drug and test formulation ( $802721 \pm 32 \mu\text{g.hr/ml}$  and  $8630128 \pm 25 \mu\text{g.hr/ml}$ ). The above results indicated that the bioavailability of the test formulation was increased significantly compare with pure drug. The  $t_{1/2}$  for optimized test formulation and pure drug was  $1.135 \pm 0.142\text{h}$  and  $1.253 \pm 0.213\text{h}$ , respectively.

Table 13: Comparison of pharmacokinetic parameters of Amlodipine besylate coated pellets and Pure Amlodipine besylate in Rats (Mean  $\pm$  SD, n = 6).

Parameters	Test formulation(F5)	Pure Amlodipine besylate
Dose (mg/kg)	2.5	2.5
$C_{max}$ ( $\mu\text{g/ml}$ )	$1050 \pm 24$	$950 \pm 32$
$AUC_{0-t}$ ( $\mu\text{g.hr/ml}$ )	$17678 \pm 745$	$15995 \pm 055$
$AUC_{0-inf}$ ( $\mu\text{g.hr/ml}$ )	$18789 \pm 735$	$17006 \pm 045$
$T_{max}$ (Min)	$15 \pm 22$	$30 \pm 15$
$t_{1/2}$ (h)	$1.005 \pm 0.142$	$1.263 \pm 0.213$
$K_{el}$ ( $\text{h}^{-1}$ )	$0.293 \pm 0.23$	$0.246 \pm 0.42$

Table 15: Comparison of pharmacokinetic parameters of Nebivolol hydrochloride coated pellets and Pure Nebivolol hydrochloride in rat (Mean  $\pm$  SD, n = 6).

Parameters	Test formulation (F5)	Pure Nebivolol hydrochloride
Dose (mg/kg)	5	5
$C_{max}$ ( $\mu\text{g/ml}$ )	$2152 \pm 125$	$2001 \pm 243$
$AUC_{0-t}$ ( $\mu\text{g.hr/ml}$ )	$8430137 \pm 2$	$783861 \pm 73$
$AUC_{0-inf}$ ( $\mu\text{g.hr/ml}$ )	$8630128 \pm 25$	$802721 \pm 32$
$T_{max}$ (Min)	$15 \pm 42$	$30 \pm 35$
$t_{1/2}$ (h)	$1.135 \pm 0.142$	$1.253 \pm 0.213$
$K_{el}$ ( $\text{h}^{-1}$ )	$0.392 \pm 0.33$	$0.296 \pm 0.42$



## Conclusion

In this work, systematic studies were conducted on drug (AMD and NBV) coated pellets, prepared by using  $3^2$  full factorial design optimize the formulation of pellets using HPC-EF as hydrophilic polymer and PVP K 30 as binder. In order to optimize formulations, two polymers HPC-EF and PVP K 30 as factors and amount of polymers (three different concentrations), were taken as independent variables. The drug coated pellets were evaluated for bulk density, tapped density, Hausner's ratio, Carr's index and angle of repose, % yield of pellets, drug content, drug loading efficiency, moisture content and friability and found to be within the Indian Pharmacopoeal limits. Based on the physicochemical properties, evaluation parameters and in vitro dissolution studies, it was concluded that F5 finalized as optimized formulation. By using the factorial design with 4% of HPC-EF and 1% of PVP K 30 we could achieve a maximum drug release of  $99.59 \pm 0.40$  and  $99.21 \pm 0.29$  by the end of 8 min for Amlodipine besylate and Nebivolol HCl

respectively, when compared with the marketed product (NEBISTAR-AM) the % of Amlodipine besylate and Nebivolol HCl was  $83.91 \pm 0.21$  and  $82.67 \pm 0.26$  within 8 min. From the above results we can conclude that the release of the drug from the pellets is depended on the concentration of the HPC-EF but very minute effect is observed with PVP K 30. The optimized formulation (F5) was characterized by SEM analysis to find out the pellet shape and surface morphology and found to be spherical in shape and smooth surface with minimal pores, indicating the uniform coating of the pellets. The comparison of in vivo bioavailability studies of the Amlodipine besylate and Nebivolol hydrochloride coated pellets and that of a pure drugs confirmed that the drug coated pellets shown immediate release and increased oral bioavailability.

Therefore, the present AMD and NBV coated pellets are considered to be potentially useful for the treatment where improved patient compliance and convenience is expected.

## References

- [1]. Ammar HO, Salama HA, Ghorab M, Mahmoud AA. Formulation and biological evaluation of glimepiride–cyclodextrin–polymer systems. *Int J Pharm.* 2006; 309 (1–2):129–138.
- [2]. Frick A, Moller H, Wirbitzki E. Biopharmaceutical characterization of oral immediate release drug products. *In vitro/in vivo* comparison of phenoxymethylpenicillin potassium, glimepiride and levofloxacin. *Eur J Pharm Biopharm.* 1998; 46 (3):305–311.
- [3]. Elaine M, Merisko-Liversidge, Gary G. Liversidge. Drug Nanoparticles: Formulating Poorly Water-Soluble Compounds, *Toxicol Pathol.* 2008; 36(1): 43-48.
- [4]. Bhanu Prasad M, Vidyadhara S, Sridhar C, Talamanchi Balakrishna, Pavuluri Trilochani. Development and evaluation of diltiazem hydrochloride controlled-release pellets by fluid bed coating process. *J Adv Pharm Technol Res.* 2013; 4(2): 101–107.
- [5]. Srujan Kumar M, Binayak Das, S.V.S. Rama Raju. Formulation and Evaluation of Multiunit Pellet System of Venlafaxine Hydrochloride. *JPBMS.* 18(5), 1-12.
- [6]. Ghebre-Sellassie I, Pellets: A general overview. In Ghebre-Sellassie Pharmaceutical Pelletization Technology. I (ed.), Vol. 37, Marcel Dekker, Inc., New York, USA, 1989, 1-13.
- [7]. Scheff E H. Experiments with mixtures. *J Royal Stat Soc Ser B,* 20, 1958, 344–360.
- [8]. Mohamed Raffick M, Muthu Mohamed J, Vetrivelvan S, Vignesh M, Selvakumar K, Parkavi V, Joysa Ruby J. Preparation and evaluation of in-vitro release kinetics of novel bilayer metoprolol succinate as sustained release and amlodipine besylate as immediate release tablets. *Int J of Biol & Pharma Res.* 2012; 3(2): 284-296.
- [9]. Suresh Kumar P, Srikanth B, Satyanarayana T, Shaji G, Navaneetha Krishnan S, Saranya P. Formulation and evaluation of nebivolol mucoadhesive buccal tablet, *Pharmacol online.* 2011; 869-885.
- [10]. Hubert M, Sarsfield B, Shekunov B, Grosso J. Oral solid dosage form: from choice of particle size technique to method development and validation. *Am. Pharm Rev,* 2008; 11(6), 14-23.
- [11]. Mihir K, Raval Riddhi V, Ramani Navin R, Sheth Formulation and evaluation of sustained release enteric-coated pellets of budesonide for intestinal delivery, *International Journal of Pharmaceutical Investigation.* 2013; 3 (4): 203-211.
- [12]. Amtun Noor, Sathesh Babu PR, Aravind P. Formulation Development and In Vitro Evaluation of Immediate Release Fenofibrate Pellets. *Asian J Comple & Alternative Med.* 2014; 02 (03): 01-06.
- [13]. Bhanu Prasad M, Vidyadhara S, Trilochani P. Development and evaluation of diltiazem hydrochloride controlled-release pellets by fluid bed coating process. *J Adv Pharm Technol Res.* 2013, 4(2): 101-107.
- [14]. Tiwari SB, Murthy TK, Pai RM, Mehta PR, Chowdary PB. Controlled Release Formulation of Tramadol Hydrochloride Using Hydrophilic and Hydrophobic Matrix System, *AAPS PharmSciTech.* 2003; 4(3): 18-23.
- [15]. Rajesham VV, Rajyalakshmi G, Reddy AN, Shekar, Anbu J. Effect of



- Nifedipine on the Pharmacodynamic Parameters of Simvastatin in Hyperlipidemic rats. *J of Phar Res.* 2009; 2(4): 642-643.
- [16]. Rajesham VV, Rajyalaxmi G, Anbu J, simultaneous determination of simvastatin and nifedipine in rat plasma by high performance liquid chromatography and pharmacokinetic studies, *Pharmacologyonline.* 2008; 3:346-353.
- [17]. Sharma D, Jain A, Shrivastava A. Simultaneous Estimation of Amlodipine Besylate, Nebivolol Hydrochloride In Tablet Dosage Form By Reverse Phase High Performance Liquid Chromatographic Using Ultraviolet Detection. *Pharm Methods.* 2011; 2(1): 9–14.
- [18]. *Biomacromolecules,* 2010. 11(5): p. 1273-1280.
- [19]. Hirenkuma KM, Steven JS. Poly Lactic-co-Glycolic Acid (PLGA) as Biodegradable Controlled Drug Delivery Carrier. *Polymers,* 2011. 3(3).
- [20]. Fonseca C, Simoes S, Gaspar R. Paclitaxel-loaded PLGA nanoparticles: preparation, physicochemical characterization and in vitro anti-tumoral activity. *J Control Release,* 2002. 83(2): p. 273-286.
- [21]. Xiong XY, Tam KC, Gan LH, Release kinetics of hydrophobic and hydrophilic model drugs from pluronic F127/poly(lactic acid) nanoparticles. *J Control Release,* 2005. 103(1): p. 73-82.
- [22]. Jeong Y-I. et al., *Clonazepam release from core-shell type nanoparticles in vitro.* *Journal of Controlled Release,* 1998. 51(2–3): p. 169-178.
- [23]. Lavasanifar A, Samuel J, Kwon GS. *Poly(ethylene oxide)-block-poly(l- amino acid) micelles for drug delivery.* *Advanced Drug Delivery Reviews,* 2002. 54(2): p. 169-190.
- [24]. Gref R. et al., *Biodegradable long-circulating polymeric nanospheres.* *Science,* 1994. 263(5153): p. 1600-3.

