

Utah State University

DigitalCommons@USU

All Graduate Theses and Dissertations

Graduate Studies

5-2016

Achieving Uniform Flow Distribution in Compact Irrigation Splitter Boxes with High Flow Rates

Joshua Ryan Hogge
Utah State University

Follow this and additional works at: <https://digitalcommons.usu.edu/etd>



Part of the [Civil and Environmental Engineering Commons](#)

Recommended Citation

Hogge, Joshua Ryan, "Achieving Uniform Flow Distribution in Compact Irrigation Splitter Boxes with High Flow Rates" (2016). *All Graduate Theses and Dissertations*. 4630.

<https://digitalcommons.usu.edu/etd/4630>

This Thesis is brought to you for free and open access by the Graduate Studies at DigitalCommons@USU. It has been accepted for inclusion in All Graduate Theses and Dissertations by an authorized administrator of DigitalCommons@USU. For more information, please contact digitalcommons@usu.edu.



ACHIEVING UNIFORM FLOW DISTRIBUTION IN COMPACT IRRIGATION
SPLITTER BOXES WITH HIGH FLOW RATES

by

Joshua Ryan Hogge

A thesis submitted in partial fulfillment
of the requirements for the degree

of

MASTER OF SCIENCE

in

Civil and Environmental Engineering

Approved:

Michael C. Johnson
Major Professor

Blake P. Tullis
Committee Member

Marvin W. Halling
Committee Member

Mark R. McLellan
Vice President for Research and
Dean of the School of Graduate Studies

UTAH STATE UNIVERSITY
Logan, Utah

2016

ABSTRACT

Achieving Uniform Flow Distribution in Compact Irrigation Splitter Boxes with High
Flow Rates

by

Joshua R. Hogge, Master of Science

Utah State University, 2016

Major Professor: Dr. Michael C. Johnson
Department: Civil and Environmental Engineering

On most irrigation canals and supply lines, there are multiple water users who divert their allotted share of water from different locations. Irrigation splitter boxes are often installed and used in piped irrigation systems to divert water to multiple shareholders and water users from a single location. The purpose of a splitter box is to accurately divert a specific amount of water from the box so that each user receives their allotted portion, regardless of the flow rate in the system. The boxes, which are usually small and compact, generally include two compartments separated by a wall that acts as a weir for the water to flow over. The water in the supply pipe enters the box and fills the upstream compartment until it spills over the weir. On the downstream side of the weir exist a number of smaller compartments that are separated by vertical dividers and lead to outlet pipes. Each divider is positioned to split a certain percentage of the total flow to one of the outlet pipes, which is then carried to another destination. In general, splitter

boxes perform very well at lower flow rates. However, if high flow rates are present in the box, due to under-design of the box or for any reason, the water surface becomes turbulent and the flow profile over the weir becomes disturbed and non-uniform. These conditions are undesirable in splitter boxes because the flow becomes unevenly distributed and an accurate flow split cannot be achieved. This study focuses on developing a solution that can be installed in existing or new flow splitter boxes to effectively dissipate energy and uniformly distribute the flow across the length of the weir during times of high flow rates.

(120 pages)

PUBLIC ABSTRACT

Achieving Uniform Flow Distribution in Compact Irrigation Splitter Boxes with High Flow Rates

Joshua R. Hogge

In many irrigation systems and networks, there are multiple water users and shareholders who take their water from different locations along a single canal or pipeline. Often, irrigation splitter boxes are used to divert water to multiple shareholders from a single location. The splitter boxes, which can be small and compact, are generally installed at different locations along a piped irrigation supply line. The purpose of a splitter box is to split a specific amount of water so that each user receives their allotted portion, regardless of the flow rate in the system.

Each splitter box usually includes two compartments, separated by a wall that acts as a weir for the water to flow over. The water in the supply pipe enters the box and fills the upstream compartment until it spills over the weir. As water flows over the weir, it is separated by vertical dividers. Each divider is positioned to split a certain percentage of the total flow to one of the outlet pipes, which carry the water to various destinations. In general, splitter boxes perform very well at lower flow rates. However, if high flow rates are present in the box, due to under-design of the box or for any reason, the water surface becomes turbulent and the flow profile over the weir becomes disturbed and non-uniform. Because of these conditions, the flow becomes unevenly distributed and an accurate flow split cannot be achieved.

This study focuses on developing a solution that can be installed in flow splitter boxes to effectively dissipate energy and uniformly distribute the flow across the length of the weir during times of high flow rates.

ACKNOWLEDGMENTS

This study was successfully completed thanks to the help of many individuals who gave of their time and expertise to contribute in the many different facets of this work. I would like to thank Mike Johnson for giving me the opportunity to work on this project from start to finish and seeing me through to the end with his helpful insights and suggestions. Thanks to my other committee members Blake Tullis and Marv Halling for providing feedback and suggestions for this thesis.

Thanks to Zac Sharp for his suggestions and willingness to allow data to be taken during the busy schedule at the Utah Water Research Laboratory. Thanks to the rest of the shop crew and graduate students that helped to build and modify the model and assist in the data collection process.

Thanks to Brian Deeter, Bryce Wilcox, Nate Smith, and Jon Frazier from J-U-B Engineers, INC. for the chance to work with them in building the model and finding a solution to improve the operation of the splitter box. Also, they provided the opportunity to travel to Colorado to see the implementation of the preferred solution in a prototype splitter box. This trip brought everything full circle to see the application of the research that was done.

And finally, my loving thanks go to my wife LauraLyn for being supportive and understanding throughout the duration of my schooling and this research process as it was often required to spend long, extra hours taking data and completing assignments.

Joshua R. Hogge

CONTENTS

	Page
ABSTRACT.....	ii
PUBLIC ABSTRACT	iv
ACKNOWLEDGMENTS	vi
LIST OF TABLES	ix
LIST OF FIGURES	xi
NOTATION.....	xiv
CHAPTER	
I. INTRODUCTION	1
II. LITERATURE REVEIW	5
III. EXPERIMENTAL LABORATORY METHODS	10
Physical Scale Model	10
Similarity	10
Model Construction	12
Design and Testing Procedure.....	15
Configurations and Designed Fixes	17
Measuring the Flow Split	25
Measuring the Upstream Pressure Head	26
IV. RESULTS	27
Visual Inspection.....	27

Flow Split Testing	29
Upstream Pressure Head	33
Splitter Box Field Data.....	35
V. DISCUSSION	37
Visual Inspection.....	37
Flow Splitting.....	38
Uncertainty Analysis	40
Upstream Pressure Head	42
Splitter Box Field Data.....	44
VI. CONCLUSIONS	47
REFERENCES	50
APPENDICES	51
Appendix A: Scale Ratio Derivations	52
Appendix B: Drawings of Tested Configurations and Designed Fixes	54
Appendix C: Drawing of Complete Setup in Lab	82
Appendix D: Flow Split Data.....	84
Appendix E: Upstream Pressure Head Data	101

LIST OF TABLES

Table	Page
1. Difference between Max. and Min. Flow Splits – Config. 1.....	31
2. Difference between Max. and Min. Flow Splits – Config. 2.....	31
3. Difference between Max. and Min. Flow Splits - Config. 3.....	31
4. Difference between Max. and Min. Flow Splits – Config. 4.....	31
5. Total measured flow and flow split for Config. 1-8.	32
6. Upstream head added to system at 6 in. away from wall.....	34
7. Upstream head added to system at 12 in. away from wall.....	35
8. Average Flow Split from Field Data.....	36
9. Flow split data for Config. 1-Baseline.....	85
10. Flow split data for Config. 1-6.....	86
11. Flow split data for Config. 1-7.....	87
12. Flow split data for Config. 1-8.....	88
13. Flow split data for Config. 1-8a.....	89
14. Flow split data for Config. 1-9.....	90
15. Flow split data for Config. 2-Baseline.....	91
16. Flow split data for Config. 2-6.....	92
17. Flow split data for Config. 2-8.....	93
18. Flow split data for Config. 3-Baseline.....	94
19. Flow split data for Config. 3-6.....	95
20. Flow split data for Config. 3-7.....	96

21. Flow split data for Config. 3-8.....	97
22. Flow split data for Config. 4-6b.....	98
23. Flow split data for Config. 4-8b.....	99
24. Flow split data for Config. 4-10.....	100
25. Upstream Pressure Head Data for Configuration 1.	102
26. Upstream Pressure Head Data for Configuration 2.	104
27. Upstream Pressure Head Data for Configuration 3.	105
28. Upstream Pressure Head Data for Configuration 4.	106

LIST OF FIGURES

Figure	Page
1. Plan View of an Irrigation Splitter Box.	1
2. High Flow Rate Passing Through a Splitter Box.....	3
3. Drawing in Profile View of Constructed Splitter Box.....	13
4. Constructed splitter box model at UWRL.	14
5. Second box built to collect the flow split.....	14
6. Third box built with a sluice gate.	15
7. Profile view drawing of configuration 3.....	18
8. Profile view drawing of configuration 4.....	18
9. Designed fixes 1, 5, 6b, and 7.....	23
10. Profile views of splitter box with designed fixes 1, 3, 4, 6, and 6a.	24
11. Config. 1-Baseline with the high flow of 8 cfs.....	28
12. Config. 1-6 with the high flow of 8 cfs.....	28
13. Average flow split percent difference for configurations 1 and 2.	30
14. Average flow split percent difference for configurations 3 and 4.	30
15. Avg. upstream pressure head for designed fixes 6 in. away from wall.	33
16. Avg. upstream pressure head for designed fixes 12 in. away from wall.	34
17. Config. 3-Baseline at high flow rate.....	39
18. Config. 3-6 at high flow rate.....	39
19. Config. 4-6b at high flow rate.....	40
20. Prototype splitter box before vertical plate was installed.	45

21. Prototype splitter box after vertical plate was installed.....	45
22. Scale Ratio Derivations.....	53
23. Drawing of Config. 1-Baseline.....	55
24. Drawing of Config. 1-1.....	56
25. Drawing of Config. 1-2.....	57
26. Drawing of Config. 1-3.....	58
27. Drawing of Config. 1-3a.....	59
28. Drawing of Config. 1-4.....	60
29. Drawing of Config. 1-5.....	61
30. Drawing of Config. 1-6.....	62
31. Drawing of Config. 1-6a.....	63
32. Drawing of Config. 1-7.....	64
33. Drawing of Config. 1-8.....	65
34. Drawing of Config. 1-8a.....	66
35. Drawing of Config. 1-9.....	67
36. Drawing of Config. 1-9a.....	68
37. Drawing of Config. 1-9b.....	69
38. Drawing of Config. 2-Baseline.....	70
39. Drawing of Config. 2-6.....	71
40. Drawing of Config. 2-8.....	72
41. Drawing of Config. 3-Baseline.....	73
42. Drawing of Config. 3-6.....	74

43. Drawing of Config. 3-7.....	75
44. Drawing of Config. 3-8.....	76
45. Drawing of Config. 4-6.....	77
46. Drawing of Config. 4-6b.....	78
47. Drawing of Config. 4-8.....	79
48. Drawing of Config. 4-8b.....	80
49. Drawing of Config. 4-10.....	81
50. Complete Setup of Model in the Lab.....	83

NOTATION

in. = inch

ft. = feet

fps = feet per second

gpm = gallons per minute

cfs = cubic feet per second

deg. = degree

± = plus or minus

CHAPTER I

INTRODUCTION

When irrigating farmland, various methods are used to transport and distribute irrigation water. Water can be moved in open channel canals or through piping buried underground. It can be distributed through sprinkling, drip, and flooding methods. The designs used differ throughout the world.

In some locations, irrigation splitter boxes are used to control and divert water to farmers. An irrigation splitter box is a square or rectangular concrete box that is often used in closed conduit networks. The boxes are generally small and compact, but effective at diverting fixed percentages of the total flow. The box includes an inlet where the water enters, a wall that acts as a weir and forces the water to flow over the top of the weir, and a number of outlets downstream from the weir. Figure 1 shows a drawing of an irrigation splitter box with one inlet and three outlets.

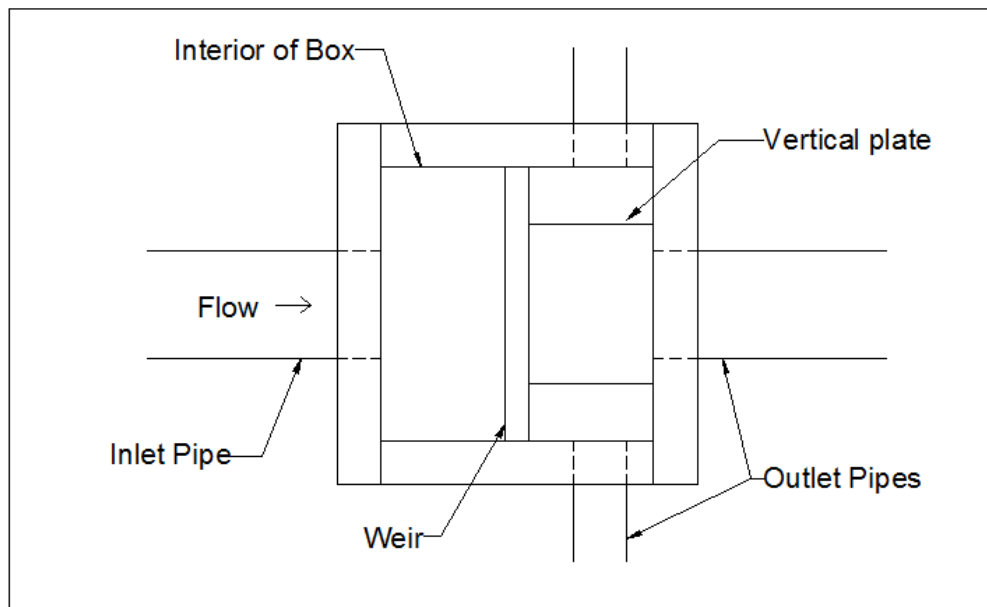

Figure 1. Plan View of an Irrigation Splitter Box.

The purpose of an irrigation splitter box is to divert a constant, pre-determined percentage of the incoming water away from the main water supply line so that it can be used by local farmers, while the majority of the water continues downstream to the next splitter box. Vertical divider plates are used to split the flow passing over the weir in each box. Splitter boxes are effective when the flow passing over the weir is uniform and evenly distributed across the length of the weir.

There can be multiple splitter boxes on a single irrigation pipeline. As the water travels downstream through each splitter box, a portion of the flow is diverted and each subsequent box receives a reduced flow rate. Because of this, higher flow rates exist at the initial boxes in the system because water has not yet been diverted to farmers. Occasionally, undesirable hydraulic conditions are produced on the upstream side of the weir due to high flow rates, as well as the compact size of the boxes. The high flow rates at the beginning of the system make it difficult to achieve uniform flow over the weirs in those boxes. Consequently, the accuracy of the flow split decreases due to the increased turbulence and the proper amount of water is not diverted from the box. Figure 2 shows a high flow rate passing through a splitter box and the resulting turbulent conditions.

One solution to this issue is to design and build larger boxes so that there is more distance upstream of the weir. However, splitter boxes are often installed and operating when hydraulic issues are discovered. Therefore, it is not feasible to shut down the flow to work on the box to achieve appropriate upstream space. The cost associated with extending an existing box or completely replacing the box would be substantial as well.

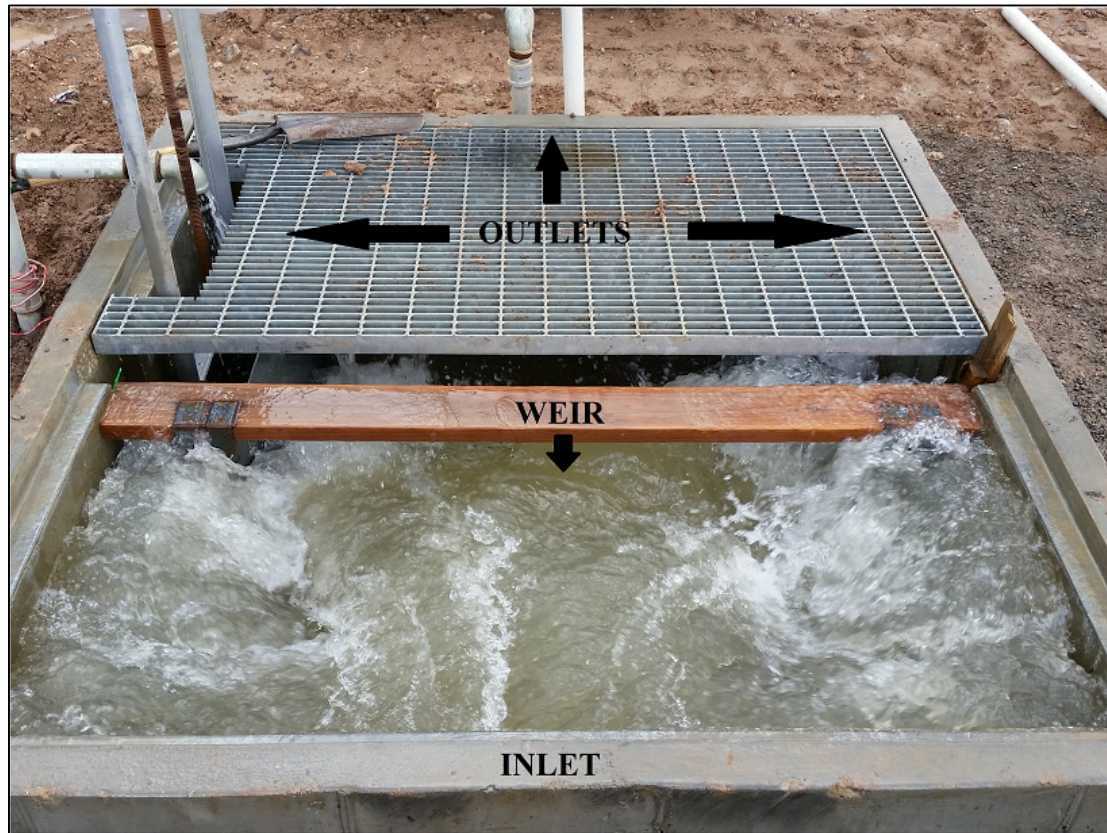

Figure 2. High Flow Rate Passing Through a Splitter Box.

The purpose of this research project was to develop a fix that could be installed in a splitter box that would force the flow profile over the weir to be as uniform as possible in a limited space. The objectives of this thesis were as follows:

- 1) Determine various methods of dissipating energy and distributing flow evenly across a weir in confined boxes.
- 2) Design and construct various fixes and analyze their performance by inspection.
- 3) Prove quantitatively that the designed fixes distribute the flow evenly across the weir by measuring the flow split in the box.

- 4) Prove quantitatively that the designed fixes dissipate energy, without producing a large amount of head loss, by measuring the pressure head in the upstream pipe and comparing to baseline conditions.

The thesis will begin by presenting a literature review to explain past research on the topic. Next, the methods that were used to conduct the physical laboratory tests and to obtain physical data will be described. The results from the data collection process will then be presented and discussed in order to show the benefits of the study.

CHAPTER II

LITERATURE REVIEW

After a thorough search of the literature, it was found that there is limited information available on the topic of irrigation splitter boxes. The literature that has been cited herein represents similar, yet, distinct and applicable subjects of research. The limited amount of research on irrigation splitter boxes allowed for a general approach to be taken in considering a variety of designs that was eventually narrowed down to a specific fix for the splitter box.

Simmons and Case conducted a model study of small weir box turnout structures used for general irrigation applications in the Columbia River Basin area in Washington (Simmons and Case 1954). The purpose of their study was to develop new turnout structure designs capable of dissipating energy, measuring flow rate, and releasing flows up to 5 cubic feet per second (cfs) from canals into small ditches. A full-scale model was built to do the testing in which the turnout structures were 3 feet (ft.) wide and ranged from 4 – 12 ft. long to accommodate various flow rates. Many different types of baffles were designed and tested for the purpose of dissipating energy in the turnout structures. The first design tested was a T-baffle used previously in the Yakima Project in Washington that forced the water to flow around and under the solid t-shaped baffle plate. This design performed well at flow rates of 2 cfs or less. The T-baffle was modified slightly by adding a cover between the upstream wall of the box to the top of the T-baffle but results did not improve. Another baffle design included a solid baffle in the middle of the structure and a second row of baffles downstream, with one baffle on each edge of the

structure. The weir wall was moved farther downstream from the inlet and a submerged cover was installed over the baffles. This design performed better and passed 5 cfs through the structure. The last design included plank baffles, made of vertical boards spaced evenly across the width of the model. There was also a submerged cover to force the water through the plank baffles. This design performed the best and was able to pass 5 cfs through the box without too much turbulence. It was concluded from the model study that for flow rates below 2 cfs, the length of the turnout structure could be decreased to 4 ft. and for flow rates from 2 – 5 cfs, the structure should be built at 7 ft. long.

Palde further studied weir box turnout structures through a full-scale model of a 4 foot weir box for the Wahluke Branch Canal as part of the Columbia Basin Project in Washington (Palde 1972). The purpose of the model study was to improve the hydraulic operating conditions of the weir boxes at higher flow rates. The box modeled by Palde was designed to pass flows of 10 cfs. Like the model study performed by Simmons and Case, the 4-foot weir box model focused on the turnout structure after water had been diverted from the main canal to a smaller ditch. The initial baffle configuration, consisting of six baffles that were evenly spaced across the width of the box, did not give good results at high flow rates, as boils and turbulence were present at the water surface. The first modification included using the same baffles, but arranged differently to increase the flow area at the quarter points of the box width. There were no significant improvements in the box. Another modification used only five of the baffles spaced evenly across the width to increase the total flow area. Flow conditions improved but

were not satisfactory. The next modification included using 12 two-inch-wide baffles. Various arrangements of the baffles were tested and the velocity distribution improved significantly. In the final design, it was determined that the weir box should be kept the same size (4 ft. by 4 ft.) and that the baffle arrangement should include 12 evenly spaced baffles with a center opening slightly bigger than the other openings. These designs provided satisfactory results at flow rates up to 13 cfs.

Peterka authored a paper on energy dissipation basins and designs that provide methods of energy dissipation by direct impact (Peterka 1984). In the paper, a design referred to as a Type VI Impact Basin is described which acts as a hanging baffle plate to dissipate the energy associated with high velocity flow rates. The design of the hanging baffle plate includes a concrete baffle positioned directly in line of the high velocity jet to spread the flow and achieve energy dissipation. The design has been tested and performs as desired when operating below maximum velocities of 50 fps and Froude numbers less than 10.

Clemmens et al. wrote about the length and size requirements for an approach channel upstream of a weir (Clemmens et al. 2001). The following design requirements were given in order to achieve completely uniform flow at a weir. First, the dimensionless Froude number was used to quantify values that should not be exceeded in order to accurately measure the flow over a weir. The equation for the Froude number used by the authors is presented in equation 1.

$$Fr_1 = \frac{v_1}{\sqrt{\frac{gA_1}{B_1}}} \quad (1)$$

where v_I is the average flow velocity, g is the acceleration of gravity, A_I is the cross-sectional area perpendicular to the flow, and B_I is the top-width of the water surface. According to the authors, if the Froude number stays below 0.5 from the gauging station to a distance of at least 30 times the maximum head ($H_{1\max}$) upstream from the weir, uniform and steady flow will be achieved. The gauging station is usually located a short distance upstream from the weir where there are no drawdown effects. Second, the channel should be straight and uniform without bends for a distance of at least 30 times $H_{1\max}$. Third, over the same distance of 30 times $H_{1\max}$, there should be no turbulent flow entering into the channel. Following these recommendations should allow for completely uniform flow at a weir. However, the authors further explained that these design requirements cannot always be met due to various restrictions. If sufficient upstream distance is not available, baffles or other wave suppressors are often used to calm the water surface. If these objects are used in the upstream channel, the required distance upstream of the gaging station can be reduced to 10 times $H_{1\max}$.

During the study on splitter boxes, the flow split was measured using various weir lengths to divert a set percentage of the total flow. The smallest weir lengths that were used to measure flow were short enough that the potential surface tension and side wall effects, and resulting inaccurate data, were considered. A study was referenced to ensure proper and viable data collection could occur with short weir lengths. Johnson conducted a study to determine discharge coefficient scale effects for both flat-topped and sharp-crested weirs (Johnson 2000). During the study, tests were conducted to measure the effects of the sidewalls on the discharge coefficient. To accomplish this, the effective

length of the weir was shortened to be able to measure the discharge coefficient over a shorter weir length and to compare it to the discharge coefficient over the entire weir length. The tests were completed and it was found that there was less than $\pm 0.5\%$ change in the discharge coefficient values. This proved that sidewall and edge effects are minimal when measuring the discharge coefficient over a weir. It was therefore determined, that the smallest flow splits with the shorter weir lengths could be accurately measured and data could be confidently taken without having to correct for sidewall effects.

The research topic of compact splitter boxes with high flow rates is unique and different than what has been done in the past. The model studies discussed in this literature review dealt with turnout structures after the water had been diverted from the main canal. Splitter boxes are usually placed on a main canal in a pressurized irrigation system and this study focuses on fixing the turbulent conditions that exist therein when there are high flow rates present. The other literature in this review presented criterion and specific parameters that are important when designing and working with weirs. Because splitter box designs include the use of weirs, the findings were taken into consideration when developing a solution and analyzing the data.

CHAPTER III

EXPERIMENTAL LABORATORY METHODS

Physical Scale Model

The Utah Water Research Laboratory (UWRL) in Logan, Utah served as the location for the physical laboratory tests for this study. A physical scale model of an irrigation splitter box was constructed at the UWRL for the purpose of viewing and testing different designs and fixes. The splitter box constructed in the lab was modeled after pre-cast concrete prototype splitter boxes in use near Delta, Colorado.

Similarity

The model was scaled down from its original size to match commercially available pipe at the laboratory and model manageability. In order to accurately perform a model study and represent the critical characteristics of the prototype structure, the laws of similitude must be applied. The three types of similarity are geometric, kinematic, and dynamic.

Geometric similarity is obtained when the model is sized either larger or smaller than the prototype, but the geometric layout of the two is identical. This type of similarity is important in order for the flow patterns in the model to replicate those in the prototype (Finnemore and Franzini 2002). Geometric similarity is achieved by using a length scale ratio. The length scale ratio is defined as the prototype length of any specified dimension, like the upstream pipe diameter in this study, divided by the model length of the same dimension. The length scale ratio is presented in equation 4.

$$L_r = \frac{L_p}{L_m} \quad (4)$$

where L_p is the prototype length, and L_m is the model length. The length scale ratio for this study was 1:1.835.

Kinematic and dynamic similarity can only be attained if geometric similarity is achieved. The parameters used to obtain dynamic similarity depend on the forces present in the model. The predominant forces existing in this study were inertial and gravity forces because of the open channel nature of the splitter box. Therefore the parameter used was the Froude number. The Froude number is a dimensionless value that accounts for both the inertial and gravity forces as represented in equation 5.

$$F = \frac{V}{\sqrt{gy}} \quad (5)$$

where V is velocity, g is the acceleration due to gravity, and y is a representative linear dimension. For dynamic similarity to be achieved, the Froude number of the prototype should equal the Froude number of the model. This is shown in equation 6.

$$\frac{V_p}{\sqrt{g_p y_p}} = \frac{V_m}{\sqrt{g_m y_m}} \quad (6)$$

where the subscripts p and m represent prototype and model, respectively.

The results of the present study could be scaled to investigate splitter boxes of different sizes, as long as the geometric shape of the box remains constant. The new length scale ratio must first be calculated. With the length scale ratio known, various applicable scale ratios can be calculated. The scale ratios that were used in this study include the velocity ratio, flow ratio, and head ratio. These scale ratios would be useful to

calculate the velocities, flow rates, and upstream pressure head in a splitter box sized larger or smaller than the one used in this study. The equations to calculate these scale ratios are shown below in equations 7 - 9.

$$V_r = \sqrt{L_r} \quad (7)$$

$$Q_r = L_r^{2.5} \quad (8)$$

$$H_r = L_r \quad (9)$$

where L_r is the length ratio as defined previously. The detailed calculations used to arrive at these equations can be found in Figure 22 of Appendix A. Other scale ratios such as the force and time ratios are not included in this literature because the study focused on achieving the proper flows and velocities in the box, and on finding the corresponding pressure head increases in the upstream pipe.

Model Construction

The model splitter box was constructed from lumber and had a square layout. It was originally built with one inlet, one outlet, and a weir. This allowed solely for visual inspection of the flow surface as water flowed into the box, passed over the weir, and exited the box. Figure 3 shows a profile view drawing of the splitter box with its respective dimensions. The prototype weir structure was designed with a top plate at the top of the weir wall that extended into the upstream compartment a short distance. This was done to enable prototype installation of the splitter plates on the downstream side of the weir wall. The splitter box was modeled with the top plate installed. The top plate was also placed on the downstream side of the weir in one of the configurations to determine

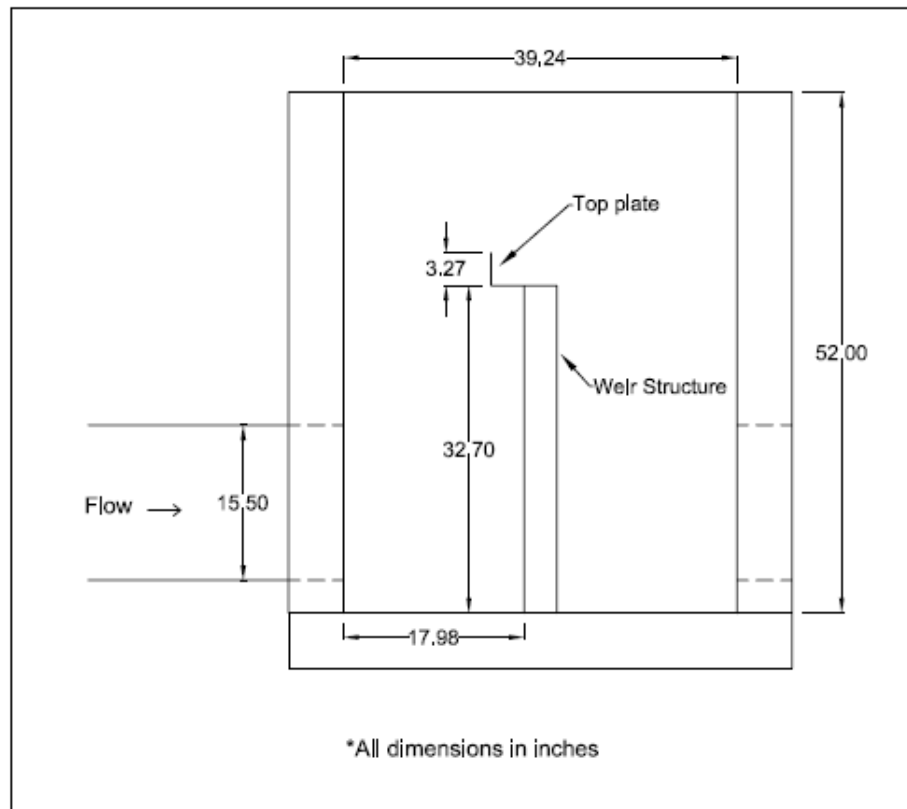

Figure 3. Drawing in Profile View of Constructed Splitter Box.

the effects of increasing the upstream distance. Figure 4 shows the constructed splitter box with its upstream piping. After initial inspection and testing was finished, a second box was built and connected to the side of the original box. This allowed a portion of the flow in the splitter box to be diverted into the second box to be collected. A third box was built with a sluice gate downstream from the second box to help measure the flow being split from the original box. The boxes were connected with steel piping and a magnetic flow meter to measure the flow rate that was split. The second and third boxes are shown in Figures 5 and 6 respectively.

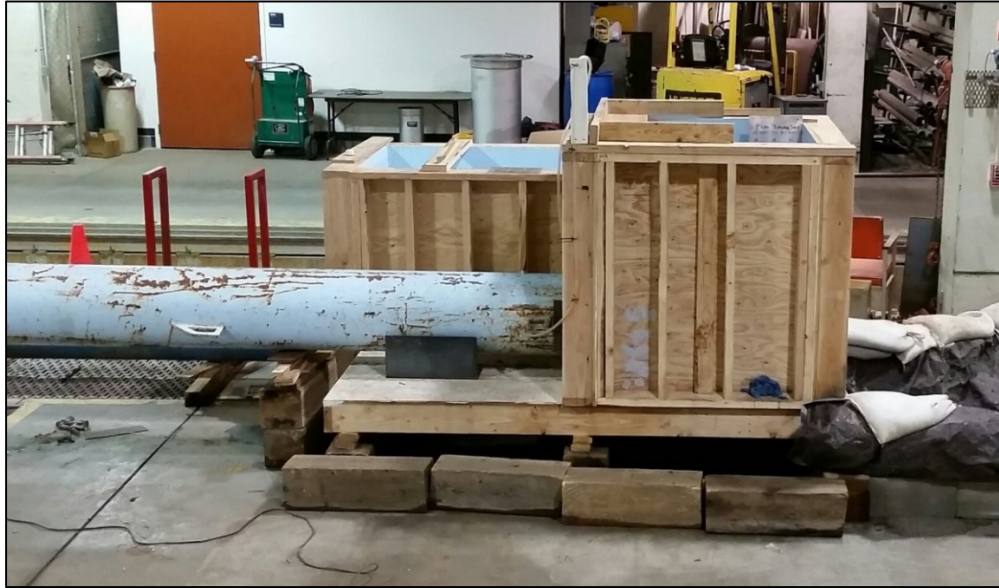

Figure 4. Constructed splitter box model at UWRL.



Figure 5. Second box built to collect the flow split.



Figure 6. Third box built with a sluice gate.

The model was supplied with water from a constant head reservoir by gravity flow. There was 42.5 ft. of straight, steel piping directly upstream from the splitter box. Of that length, there was 24.5 ft. of 12-in. pipe followed by 18 ft. of 16-in. pipe directly upstream of the box.

Design and Testing Procedure

As part of the design process in this study, many different alternatives and configurations were designed and ultimately tested to verify their effectiveness in

dissipating energy and creating a uniform flow profile over the weir. However, a large portion of this study, in its initial stages, included the discussion and drawing of various energy dissipation methods that could potentially be implemented into a splitter box model. Some of the energy dissipation and distribution methods include direct impact designs similar to that presented by Peterka (1984), winding paths that gradually force the flow to be uniform across the width of the box, and perforated plates that force the flow to be distributed more equally. Combinations of these methods were discussed and implemented. It was also necessary to incorporate into each design the ability to access the box to clean during operation and keep it free of debris. Therefore, each of the designs that were developed had to be easily removable so that the box could be cleaned and maintained when needed. This important detail proved to partially restrain the design alternatives and fixes.

After finalizing the designs to be tested, each was constructed or manufactured out of plywood or steel. The baseline configuration, the splitter box without any designed fix installed, was first tested over a range of flows from 500 to 3500 gallons per minute (gpm) and inspected visually regarding flow uniformity over the weir. Each of the designed and constructed fixes were then installed in the original box and tested over the same flow range. The results from each design were compared to the baseline configuration. The upstream pressure head was also measured for each flow rate and each design to compare to the baseline values. After data had been collected for each alternative, modifications were made and the data collection was repeated. The designs that performed poorly in the visual tests were removed and no further testing was

conducted. The designs that performed well visually were then tested quantitatively to measure the flow split performance.

Configurations and Designed Fixes

There were four splitter box designs that were tested, referred to as configurations 1-4, and 10 fixes that were designed and built to be installed in the splitter boxes, referred to as designed fixes 1-10. Each of the designed fixes was installed in configuration 1 and those that performed well were then tested in the other configurations. The following paragraph describes each of the configurations.

Configuration 1 was the original splitter box, scaled directly from the prototype box in Colorado, without any modifications. Figure 3 showed a profile view drawing of configuration 1. Each of the other configurations consisted of modifications to the original box in an attempt to improve the flow conditions. Configuration 2 included the same exterior dimensions as the original box. The top plate on the weir, however, was turned around to simulate an additional 10 in. of space upstream of the weir.

Configuration 3 consisted of extending the splitter box to create more space upstream from the weir. As a result, the distance from the upstream wall of the box to the top of the weir in the extended box was 3.67 times longer than in the original box. Configuration 4 consisted of the extended box, with the addition of a 45 deg. ramp extending from the top of the weir back down towards the floor of the box. Figures 7 and 8 show profile view drawings of configurations 3 and 4, respectively, with important dimensions. Each configuration, except for configuration 4, was first tested under baseline conditions to have a reference point for comparison.

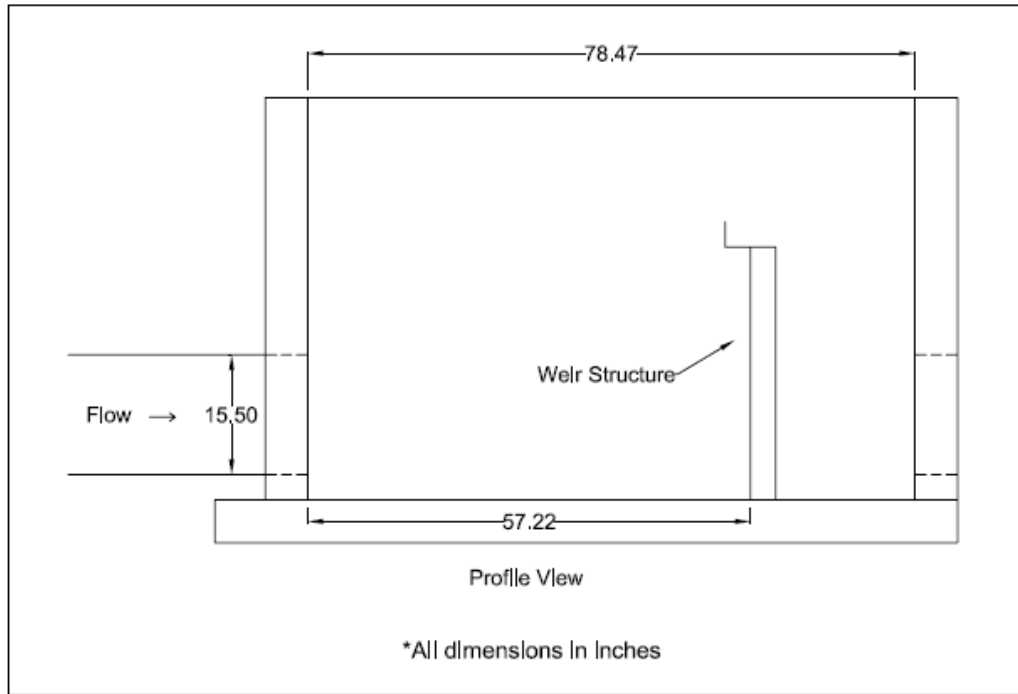

Figure 7. Profile view drawing of configuration 3.

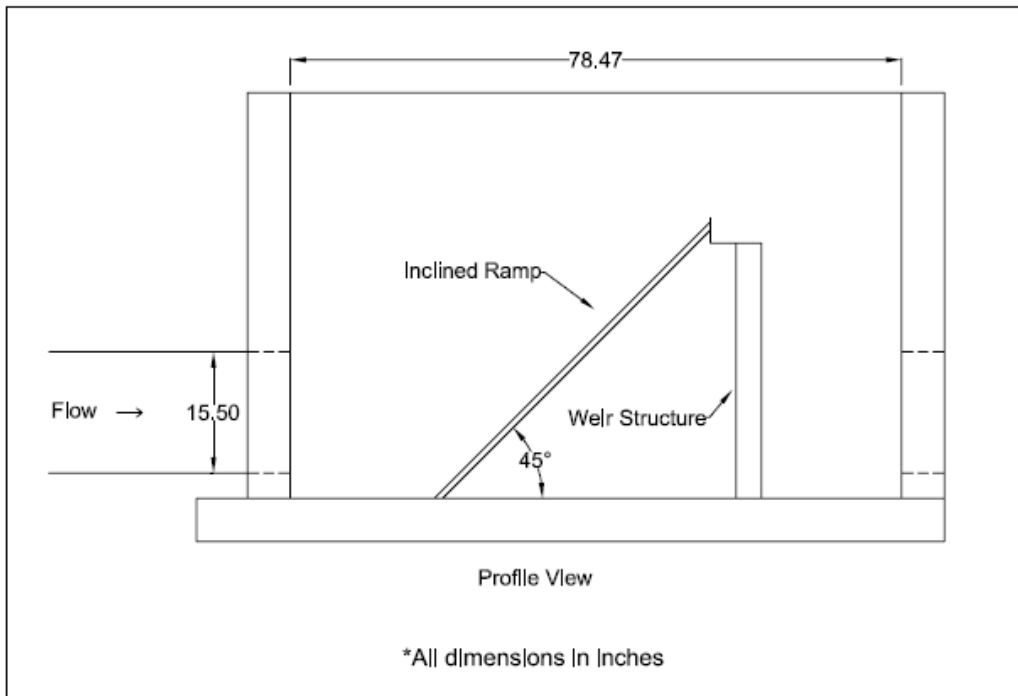

Figure 8. Profile view drawing of configuration 4.

There were 10 total fixes constructed or manufactured. Each was labeled accordingly with the numbers 1-10. Small modifications were often made to the existing designed fixes, in which case, letters were used to further distinguish between modifications to the same alternative. Therefore, each configuration and designed fix pairing was labeled in the following manner: Config. 1-1, where the first number refers to the configuration and the second number refers to the designed fix. The following paragraphs give an explanation of the designed fixes. Figures 9 and 10, which appear after the explanation of fixes, show a select few of the fixes that were designed and installed in the splitter box configurations. Detailed drawings of the configurations with installed fixes and dimensions can be found in Figures 23-49 of Appendix B.

The splitter box configurations were first tested without any designed fixes installed. This is referred to as the baseline conditions.

Designed fix 1 consisted of two horizontal perforated plates on the upstream side of the weir. The plates were spaced 12 in. apart vertically and both above the elevation of the top of the pipe. Both plates had 2" by 2" square openings equally spaced across the plate that resulted in the surface being approximately 22% porous.

Designed fix 2 also included two horizontal plates located in the same positions as fix 1. However, the plates were perforated with 1 in. diameter holes spaced evenly across the plate at 1.5 in. on center. The perforations resulted in a plate surface with approximately 35% porosity.

Designed fix 3 was an L-shaped baffle plate attached to the upstream end of the splitter box, directly downstream from where the water enters the box. The plate was

positioned so that the water was forced to flow underneath the plate after impact. The open flow area under the plate was designed to be approximately the same as the area of the upstream pipe. This design was similar to the direct impact plate presented by Peterka (1984).

Designed fix 3a moved the baffle plate downstream 5 in., creating a new flow path along the upstream wall of the box. The open flow areas were maintained to be the same as the area of the upstream pipe.

Designed fix 4 included a winding path that forced the water to travel through a conduit of flow area equal to the flow area of the pipe. The winding path terminated with a vertical perforated plate that contained 1 in. diameter holes evenly spaced at 1.5 in. on center across the plate. The plate was approximately 35% porous.

Designed fix 5 was a vertical plate with 1 in. wide vertical slits spaced evenly across the width of the plate. The distance between slits was 1.5 in. and the vertical slits extended down from the top covering slightly more than half of the plate. The plate was 0.75 in. thick and was similar in concept to the solutions of plank baffles used by Simmons and Case (1954) and Palde (1972).

Designed fix 6 was a vertical perforated plate with 1 in. diameter holes evenly spaced at 1.5 in. on center across the width of the plate. The holes extended down from the top and covered slightly more than half of the plate. The total flow area was roughly 2 times the flow area of the upstream pipe and the perforated portion of the plate was approximately 35% porous. The plate was 0.75 in. thick and had a cover at the top of the vertical plate to force water through the holes rather than passing over the top.

Designed fix 6a consisted of leaning the plate from designed fix 6 on an angle against the upstream wall of the box. The bottom of the plate was positioned 6 in. away from the bottom of the upstream wall and the top of the plate was angled back towards the top of the upstream wall.

Designed fix 6b consisted of the vertical plate from fix 6 with the top 3 rows of holes in the plate being covered to dissipate small surges that produced ripples and turbulence at the water surface at high flow rates.

Designed fix 7 was a vertical perforated plate with 1.5 in. diameter holes spaced evenly at 2 in. on center across the plate. The holes extended down from the top and covered slightly more than half of the plate. The total flow area was roughly 2.3 times the flow area of the upstream pipe and the porosity of the perforated portion of the plate was approximately 40%. The plate was 0.75 in. thick and had a cover placed on top.

Designed fix 8 was a vertical perforated plate with 0.5 in. diameter holes spaced evenly at 0.75 in. on center across the plate. The holes summed to create roughly the same total flow area as fix 7. The porosity of the perforated portion of the plate was approximately 40% and the plate was 0.25 in. thick. The plate had a cover on top.

Designed fix 8a removed 0.125 in. from each side of the plate from fix 8. The plate was positioned in the same location.

Designed fix 8b consisted of the same plate as fix 8 and the top 5 rows of holes covered to dissipate ripples at the water surface at high flow rates.

Designed fix 9 was a vertical perforated plate with 0.54 in. diameter holes that were spaced closer together to increase the porosity of the perforated portion of the plate

to 60%. The holes were spaced at 0.68 in. on center across the plate and were offset on each successive row. The holes extended down from the top covering slightly more than half of the plate, resulting in a higher flow area through the vertical plate than previous designs due to the higher porosity in the perforated portion. The thickness of the vertical plate was decreased to 0.13 in.

Designed fix 9a covered the bottom half of the rows of holes on the plate from fix 9 to create a lower flow area than in previous designs.

Designed fix 9b covered the bottom fourth of the rows of holes on the plate from fix 9 to create the same flow area as fix 7.

Designed fix 10 was similar to fix 6. However, the vertical plate had 1.01 in. diameter holes spaced evenly at 1.5 in. on center across the plate. Also, the plate was only 0.25 in. thick.

Many of the designed fixes included a vertical plate. In configurations 1, 2, and 3 the vertical plates were positioned 6 in. away from the upstream wall of the box. In configuration 4 the vertical plates were positioned 12 in. away from the upstream wall after inspection showed that this small change improved the flow profile in the box.

Figures 9 and 10 show drawings of a select few of the designed fixes that were constructed. Figure 9 shows drawings of designed fixes 1, 5, 6b, and 7 before they were installed in the box. Figure 10 shows drawings of designed fixes 1, 3, 4, 6, and 6a after they were installed in the splitter box.

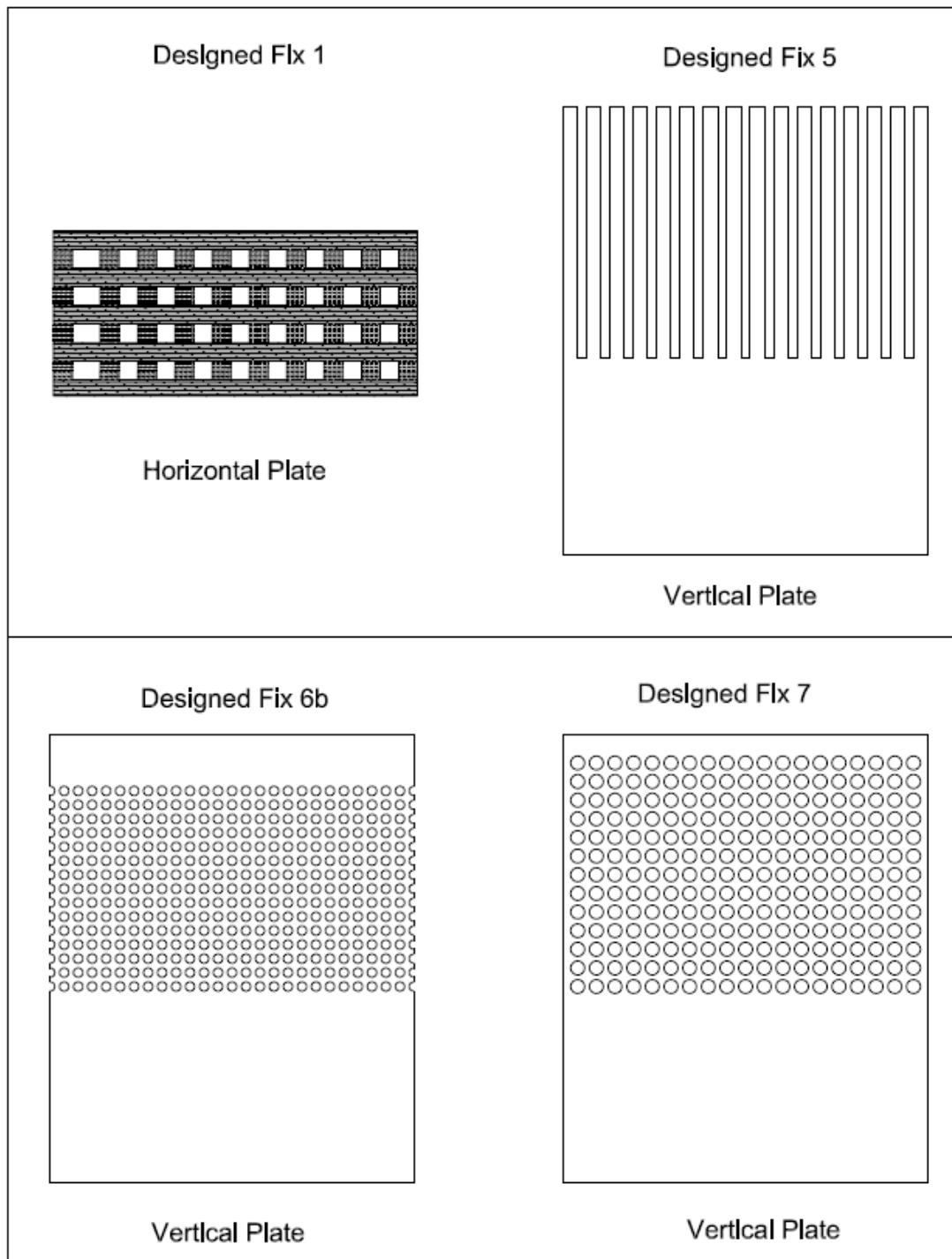

Figure 9. Designed fixes 1, 5, 6b, and 7.

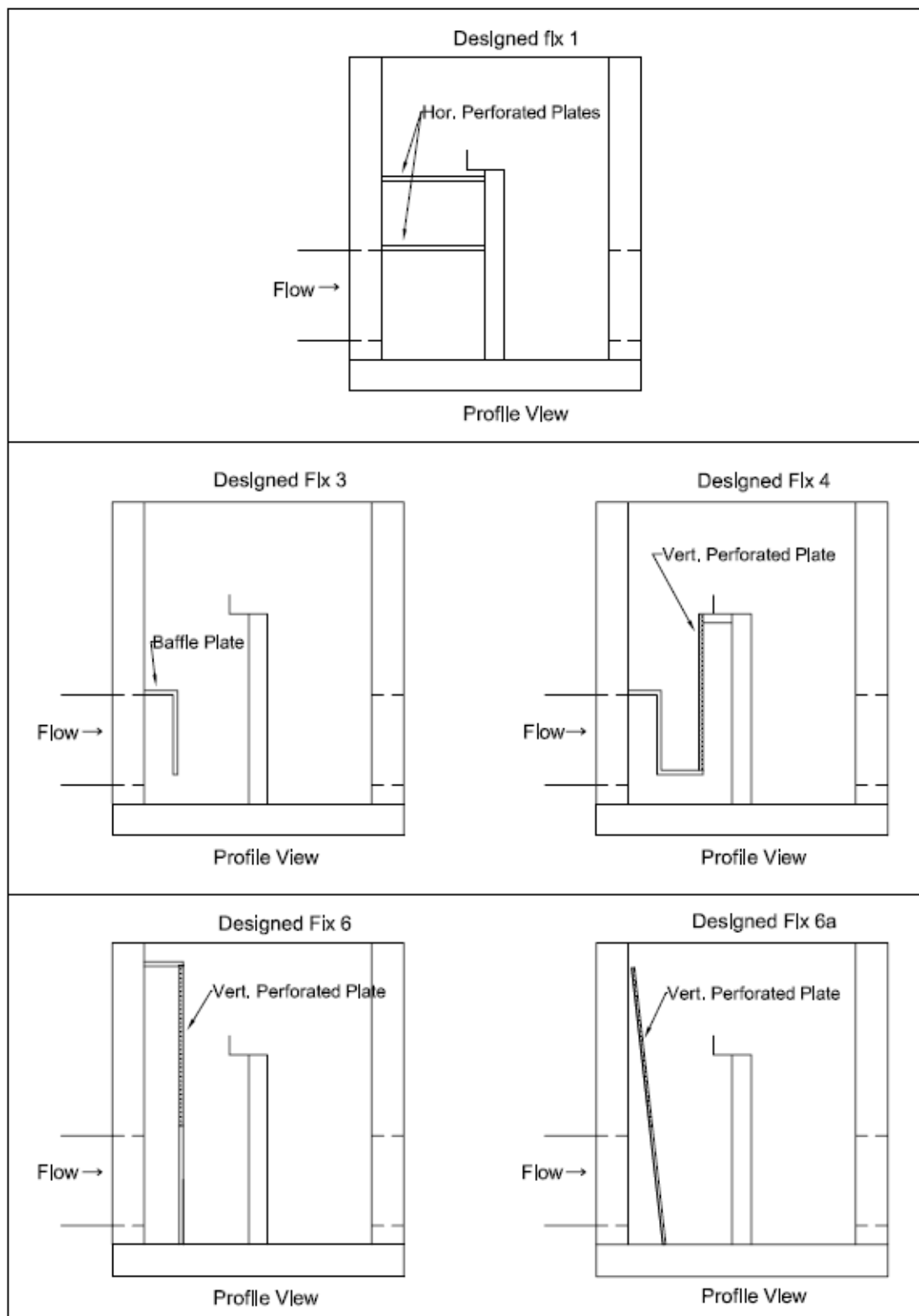

Figure 10. Profile views of splitter box with designed fixes 1, 3, 4, 6, and 6a.

Measuring the Flow Split

In order to prove that the designed fixes distributed the flow uniformly across the weir, the flow split was measured. The flow was split by a thin piece of steel that could be positioned perpendicularly to the weir at different locations along the length of the weir. The edges of the splitter were sealed so that no water was lost or added, and then, as a result, different percentages of flow could be diverted out of the box. The research conducted by Johnson (2000) proved that side wall effects were not of great concern when determining the discharge over a weir. Therefore, it was determined that very small flow percentages could be measured without having to correct for possible side wall effects. The percentages of flow that the splitter was set up to measure were 1, 2.5, 5, 10, 20, and 35%.

During testing, the flow split was measured by two calibrated magnetic flow meters placed in a pipeline between two collection boxes. A drawing of the complete setup in the lab with the flow meters can be found in Figure 50 of Appendix C. The first collection box collected the diverted water out of the main splitter box. The water then flowed through a pipeline with a flow meter to the second collection box. The second box had a sluice gate to control the downstream water level and ensure that the pipeline with the flow meter remained full of water. A 10 in. and a 2 in. magnetic flow meter were used to measure the high and low flow splits, respectively. The measured flow splits were then compared to the measured flows going into the splitter box to verify whether an accurate flow split had been achieved.

Measuring the Upstream Pressure Head

The upstream pressure head was also measured to verify how much added head was introduced into the system from each designed fix in relation to the baseline conditions. The pressure head was measured at a distance of one pipe diameter upstream from the splitter box using clear tubing and a tape measure. The measurement was referenced from the centerline of the pipe to the level in which the water had risen in the clear tubing.

CHAPTER IV

RESULTS

Visual Inspection

The purpose of the visual inspection was to determine which designs successfully forced the flow to appear more uniform as it passed over the weir at high flow rates when the turbulence in the boxes was the worst. Figure 11 shows the high flow passing through Config. 1-Baseline. All the designed fixes were tested in the original splitter box, configuration 1, during the inspection. Perfect weir flow was never achieved, but many of the designs successfully forced the flow to appear more uniformly distributed as it passed over the weir. The perforated plates, both horizontal and vertical, provided the best results. Figure 12 shows a picture of Config. 1-6, a vertical perforated plate with 1 in. holes, at the highest flow rate. The other designed alternatives, designed fixes 3-5, weren't as effective at distributing the flow evenly across the width of the box or calming the turbulent water. Therefore, fixes 3-5 were removed from consideration and were not tested further. After comparing the results from the horizontal and vertical perforated plates, the vertical plates were chosen as the better option due to the necessity of being able to clean the box and keep it free of debris. The vertical plates were easily installed and removed from the box by sliding them up and down a set of guides on the walls. The horizontal plates, however, would have to be connected to hinges or something similar to allow for debris passage, making them the less desirable option. Because of this, the focus of the study shifted to making the vertical perforated plate design more effective.



Figure 11. Config. 1-Baseline with the high flow of 8 cfs.



Figure 12. Config. 1-6 with the high flow of 8 cfs.

Flow Split Testing

The vertical perforated plates were the only designs that had flow split data taken and each plate was tested in configuration 1 before moving on to other configurations. This was done to find a successful fix without altering the dimensions of the box itself. The plates tested in configuration 1 included designed fixes 6, 7, 8, 8a, and 9. Designed fixes 9a and 9b were only visually inspected. Data collection was less vigorous for configurations 2-4 and was limited to the best-performing vertical plates, which included designed fixes 6, 7, and 8. Configuration 2 was tested under the baseline conditions and with designed fixes 6, 7, and 8. Configuration 3 was tested under the baseline conditions and with designed fixes 6 and 8. Configuration 4 was tested with designed fixes 6b, 8b, and 10, which were designed after visual inspection of configuration 4 showed that covering the top few rows of holes eliminated the disturbances to the water surface.

The results of the data collection are presented in two methods. The first method was completed by calculating the average flow splits for each designed fix at each flow split tested. This data was used to calculate the percent difference between the measured flow split and the actual splitter setting as can be seen in Figures 13 and 14. However, it was clear that the accuracy of the measured flow splits was dependent upon the placement accuracy of the flow splitter. Therefore, the data is also presented in a second method by calculating the difference between the maximum and the minimum measured flow split at each of the set percentage splits. This method showed how much the measured flow split deviated over the range of flow rates. Tables 1 – 4 show the difference between the maximum and minimum flow splits from configurations 1-4.

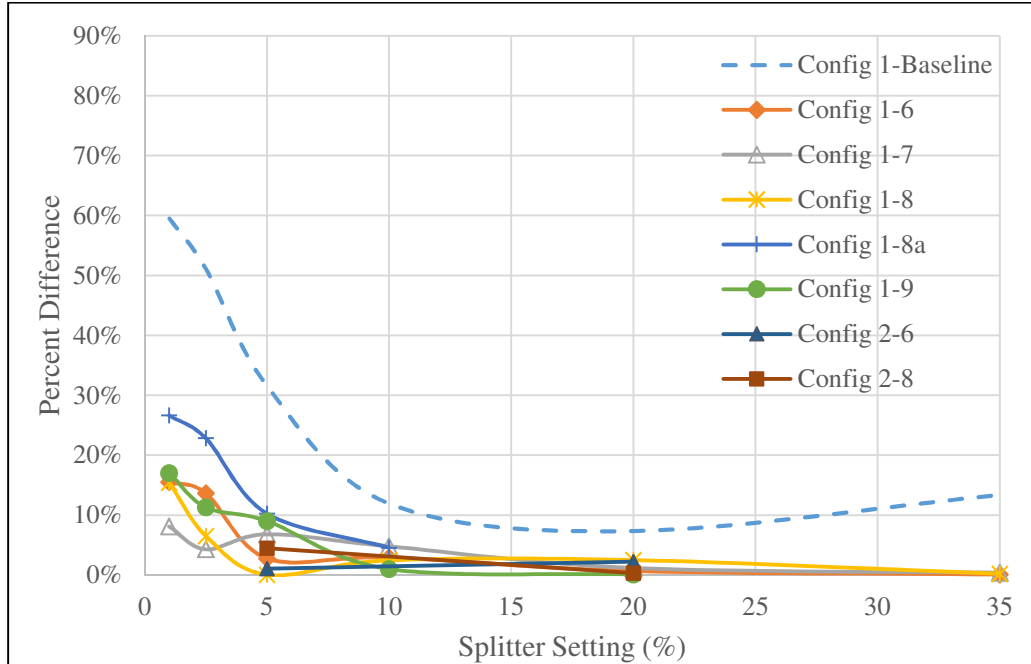

Figure 13. Average flow split percent difference for configurations 1 and 2.

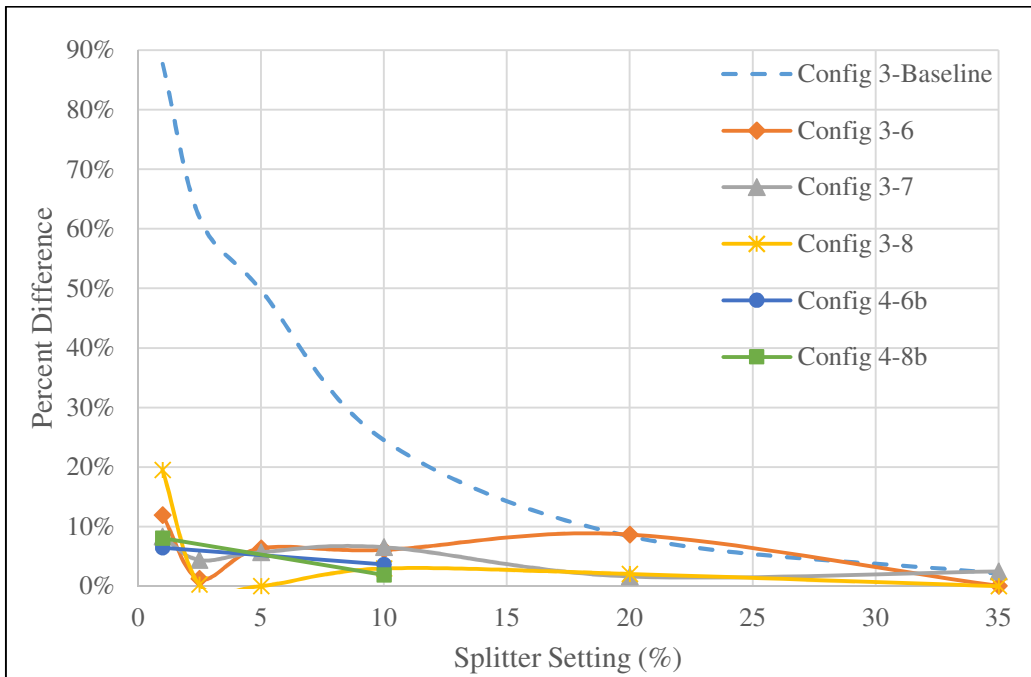

Figure 14. Average flow split percent difference for configurations 3 and 4.

Table 1. Difference between Max. and Min. Flow Splits – Config. 1.

% Split	Config.					
	1-Baseline (%)	1-6 (%)	1-7 (%)	1-8 (%)	1-8a (%)	1-9 (%)
1	0.82	0.29	0.20	0.26	0.15	0.39
2.5	1.79	0.42	0.33	0.18	0.32	0.51
5	2.74	0.57	0.76	0.42	0.23	0.70
10	2.56	1.18	1.35	1.00	0.19	0.83
20	6.16	0.23	0.57	1.08	-	0.46
35	8.08	0.42	0.64	0.71	-	-

Table 2. Difference between Max. and Min. Flow Splits – Config. 2.

% Split	Config.		
	2-Baseline (%)	2-6 (%)	2-8 (%)
5	0.91	0.34	0.36
20	0.99	0.28	0.48

Table 3. Difference between Max. and Min. Flow Splits - Config. 3.

% Split	Config.			
	3-Baseline (%)	3-6 (%)	3-7 (%)	3-8 (%)
1	1.18	0.24	0.17	0.24
2.5	2.80	0.59	0.59	0.19
5	4.51	0.79	0.74	0.42
10	3.83	1.50	1.60	1.36
20	1.40	4.21	2.32	3.18
35	1.55	1.18	2.59	1.35

Table 4. Difference between Max. and Min. Flow Splits – Config. 4.

% Split	Config.		
	4-6b (%)	4-8b (%)	4-10 (%)
1	0.12	0.09	-
10	0.22	0.22	1.00

To better illustrate the methods used to present the flow split data, Table 5 has been included. Table 5 shows the total measured flow rates and flow split data for Config. 1-8 when the splitter was positioned to split 35% of the total flow. First, the data was presented by calculating the percent difference between the measured split and the splitter setting. The average flow split was first calculated by taking the average of the measured flow splits over the range of flows, as seen in Table 5 to be 34.92% for Config. 1-8. This number was then compared to the splitter setting of 35% to calculate the percent difference, which was 0.24% for this case. The second method of presenting the data was completed by taking the difference between the maximum and minimum measured flow splits for a data set. For the data in Table 5, the maximum measured flow split was 35.28% and the minimum was 34.58%, which resulted in a difference of 0.71%. The percent difference of 0.24% and the difference of 0.71% were both represented in Figure 13 and Table 1, respectively. The data in Figures 13 and 14 and the values presented in Tables 1 – 4 were calculated as per described in this paragraph.

Table 5. Total measured flow and flow split for Config. 1-8.

Splitter Setting	Flow (gpm)	Measured % Split (%)
35%	496.6	34.80
	985.2	34.86
	1476.3	34.85
	1976.8	35.28
	2660.0	35.13
	3402.4	34.58
Average flow split =		34.92
Percent Difference =		0.24
Max - Min =		0.71

Upstream Pressure Head

The upstream pressure head was measured during the data collection for each of the designed fixes. These results were compared to the baseline values to quantify the amount of upstream pressure head added to the system. Figure 15 shows a graph of the average upstream pressure head for designed fixes 6, 7, 8, 8a, and 9 at the tested flow rates. It is important to note that these design fixes were positioned 6 in. away from the upstream wall of the box. Table 6 further analyzes the graph in Figure 15 by showing the upstream pressure head that was added to the system relative to the baseline conditions as a result of the installed fixes. Figure 16 shows a graph of the average upstream pressure head for designed fixes 6b, 8b, and 10, which were positioned 12 in. away from the upstream wall. Table 7 shows the upstream pressure head values that were added to the system relative to the baseline conditions for the fixes from Figure 16.

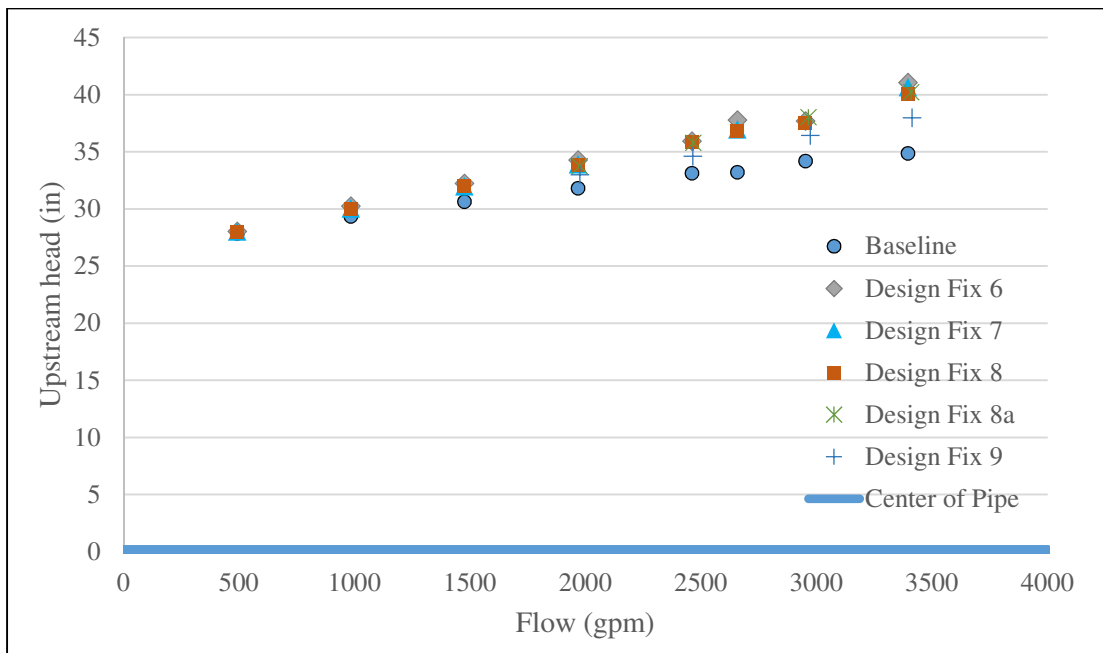

Figure 15. Avg. upstream pressure head for designed fixes 6 in. away from wall.

Table 6. Upstream head added to system at 6 in. away from wall.

Flow (gpm)	Design Fix				
	6 (in.)	7 (in.)	8 (in.)	8a (in.)	9 (in.)
492	0.18	0.17	0.15	-	-
984	0.89	0.69	0.66	-	-
1476	1.59	1.35	1.35	-	-
1968	2.47	2.11	2.08	1.94	1.19
2460	2.81	-	2.69	2.66	1.50
2657	4.57	3.74	3.58	-	-
2952	3.50	-	3.38	3.84	2.24
3395	6.19	5.80	5.17	5.35	3.11

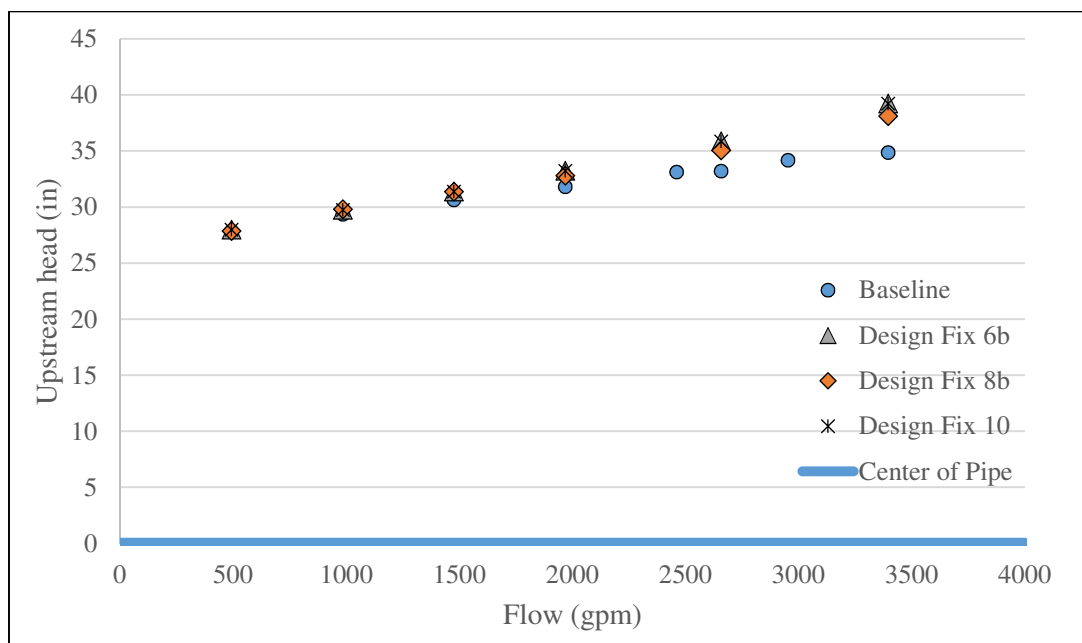

Figure 16. Avg. upstream pressure head for designed fixes 12 in. away from wall.

Table 7. Upstream head added to system at 12 in. away from wall.

Flow (gpm)	Design Fix		
	6b (in.)	8b (in.)	10 (in.)
492	0.02	0.02	0.15
984	0.33	0.46	0.40
1476	0.62	0.74	0.74
1968	0.94	1.01	1.44
2460	-	-	-
2657	1.84	1.84	2.66
2952	-	-	-
3395	2.88	3.26	4.38

The data and results presented in this chapter represent simplified and small portions of the total data that was collected in the lab during this study. Tables 9 – 24 in Appendix D present the complete flow split data that was collected in each of the configurations and with each of the designed fixes installed. Also, Tables 25 – 28 in Appendix E show the complete upstream pressure head data for each of the configurations.

Splitter Box Field Data

As was mentioned in Chapter III, the splitter box that was built at the UWRL for this study was modeled after pre-cast concrete splitter boxes in use near Delta, Colorado. J-U-B Engineers, INC. of Kaysville, Utah works closely with the farmers and irrigation board in the Delta area to improve the local irrigation systems. After most of the testing was completed at the UWRL, the author worked with a team from J-U-B Engineers, INC. to implement one of the successful designed fixes into an operating splitter box. The design that was chosen for the prototype splitter box was designed fix 8a. This design

was chosen as a result of the good lab data and to ensure that the plate would fit in the pre-cast boxes in the field because of its slightly smaller width. The vertical perforated plate was scaled up to the size of the prototype splitter boxes, manufactured to the correct dimensions, and then installed in a splitter box.

Data was taken in the field using a clamp-on ultrasonic flow meter to measure both the flow rate going into the box as well as the flow rate that was being split out one of the sides of the box. There was also a parshall flume that was available for use to measure the flow rate before the water entered into the pipeline. The ultrasonic flow meter was the preferred measurement device. However, due to large amounts of entrained air in the pipeline upstream from the splitter box, the ultrasonic flow meter struggled to produce consistent data. For this reason, the flow was also measured using the parshall flume. Flow measurements were taken and the average flow split was found based on data from both upstream measurement devices. Table 8 shows the average flow splits with the vertical perforated plate installed. The flow splitter in the box was set to split 10.4% of the total incoming flow.

Table 8. Average Flow Split from Field Data

% Split	Flow Measurement Devices	
	Ultrasonic	Parshall Flume
(%)	(%)	(%)
10.4	9.42	10.37

CHAPTER V

DISCUSSION

Visual Inspection

The visual inspection was important to see which fixes performed well enough to merit data collection. There were many potential solutions that could have been installed and used to evenly distribute the flow in the splitter box. However, not all of the designs were feasible for the requirements of cleaning and minimizing increased upstream pressure head. Therefore, the visual inspection ultimately allowed for the designs to be quickly analyzed and for the data collection process to be focused on the best-performing fixes.

The visual inspection also aided in identifying the hydraulic issues that occurred in the splitter box. The primary issue in the box that was immediately visible included large boil-ups in the corners and the middle of the box. This was due to the sudden transitions from horizontal velocity components in the pipe to predominantly vertical velocity components in the box. Generally, water particle streamlines follow a smooth path without abrupt changes in direction. However, because of the compact size of the splitter box, the water was forced to quickly change directions, which disrupted the natural flow of the streamlines and created large vertical, localized velocities that were undesirable upstream of the weir. This issue was one of the main contributors to the turbulent, non-uniform water surface present under the baseline conditions. By identifying the hydraulic conditions in the box through the visual inspection, the fixes were designed to help re-establish the natural streamline paths. The vertical perforated

plate design proved to be the most effective fix because it caused the streamlines to be re-established in the horizontal direction before the water passed over the weir.

Flow Splitting

The designed fixes were tested in configuration 1 first to find a solution without changing the overall dimensions of the box. Refer to Figures 11 and 12 to see images of configuration 1. After inspecting many different fixes, it was determined that perfect weir-flow could not be attained in configuration 1 with such limited space upstream of the weir. As a result, configurations 2 - 4 were designed to provide more distance upstream of the weir.

Configuration 2, with the weir turned around to provide more upstream distance in the box, did not produce any notable changes in the data and therefore minimal data was taken. The box was lengthened to form configuration 3 and provide even greater upstream distance from the weir. The results from configuration 3 were similar to those from configuration 1 and did not greatly improve upon the previous data. Figures 17 and 18 show Config. 3-Baseline and Config. 3-6 at the high flow rate. As seen in the figures, the addition of a vertical plate into the box greatly improved the flow uniformity. However, because the actual flow data did not improve, configuration 4 was designed and tested. Configuration 4 provided the best flow split results overall when designed fixes 6b and 8b were installed. Figure 19 shows Config. 4-6b at the high flow rate. The data from Config. 4-6b and 4-8b was very good, especially when comparing the differences between the maximum and minimum flow splits. Additionally, the flow

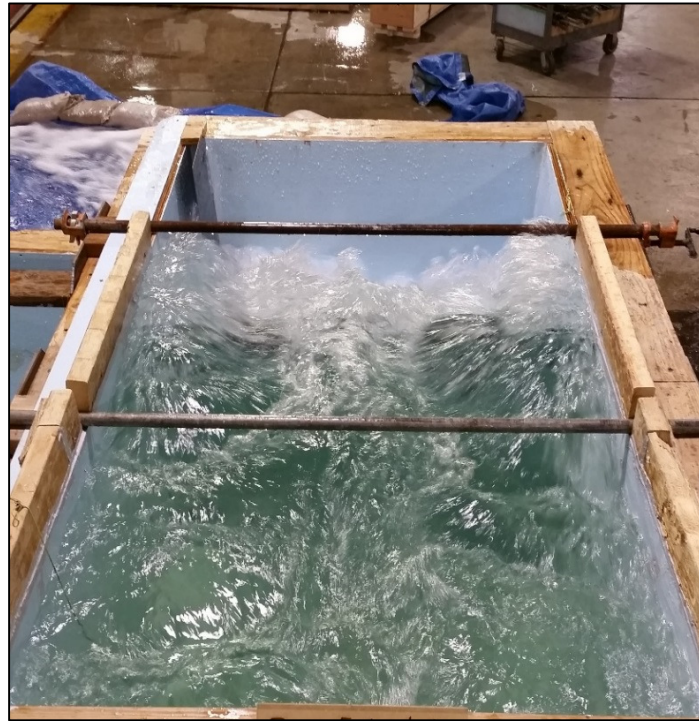

Figure 17. Config. 3-Baseline at high flow rate.

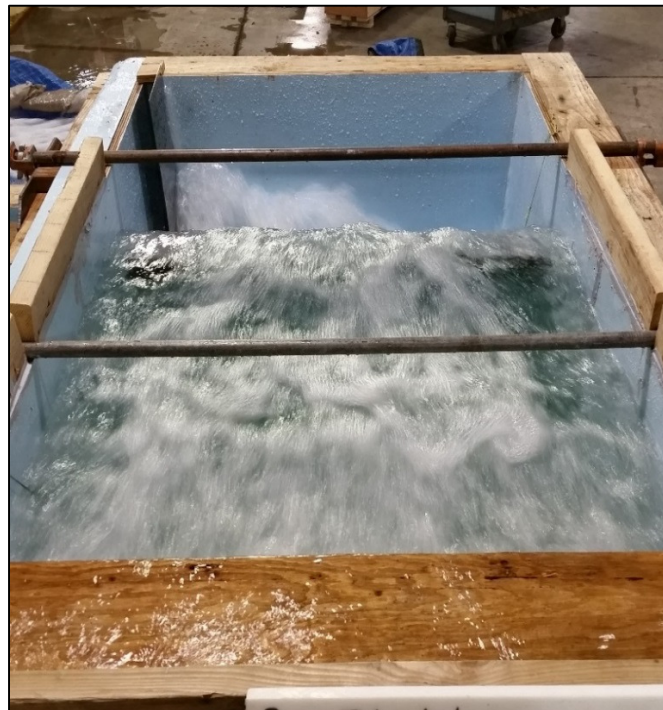

Figure 18. Config. 3-6 at high flow rate.



Figure 19. Config. 4-6b at high flow rate.

profile in the box was uniform and without large disturbances, even at high flow rates. The data showed that the combination of configuration 4 and designed fixes 6b and 8b created flow conditions that consistently split the same percentage of flow regardless of the flow rate passing through the box.

Uncertainty Analysis

During the data collection process, the perforated plates were installed and removed multiple times and the thin sheet of metal that was used to split the flow was set and re-set many times to collect all the desired data. Because of this, and due to the

difficulty of positioning the splitter at the exact location every time, there was some uncertainty introduced into the flow split data. There were also uncertainties from the magnetic flow meters that were used to measure the flow rates in the system. An uncertainty analysis was performed to determine the overall quality of the data and demonstrate the level of confidence that may be assumed for anyone using the data. Two separate analyses were performed, one to account for the splitter placement, and the second to account for the magnetic flow meters. The uncertainties for each measurement were determined using a root-sum-squares technique described by a test uncertainty manual from the American Society of Mechanical Engineers (ASME 2006).

First, for the splitter placement, the splitter was placed at the percentage splits mentioned in chapter III to within $\pm 1/32$ in. of the exact location for flow splits of 1, 2.5, 5, 10, and 20%. The precision of the splitter placement at the 35% split was within $\pm 1/16$ in. of the exact location. The analysis shows that the maximum uncertainty in splitter placement was 8% and occurred when the splitter was positioned at the smallest flow split of 1%. The uncertainty decreased to 3.2% for a split of 2.5% and the uncertainty of the remaining flow splits were all less than 1.5%.

The second uncertainty analysis involved the magnetic flow meters. Past analyses and tests at the UWRL have shown that the calibrated magnetic flow meters are accurate to within 0.5%. Using this value as a reference, the uncertainty analysis was completed and found that the uncertainty for the flow split data was less than 0.15%. An additional

analysis was done supposing that the same flow meters were only accurate to within 1%.

This resulted in an uncertainty of less than 0.5% for the flow split data.

Small errors in the splitter placement had larger effects at the smaller flow split percentages. For this reason, the data was analyzed in the two different methods described in Chapter IV to effectively understand the performance of each designed fix. It is notable here that the first method of analyzing the data, taking the average flow split over a range of flow rates, was affected by the small errors in splitter placement. However, the second method of analyzing data, comparing the difference between maximum and minimum flow splits at each set condition, was not dependent upon the accuracy of splitter placement. Instead, regardless of the placement accuracy of the flow splitter, the data showed how much the flow split varied for each set percentage, which represented the effectiveness of the designed fixes.

Upstream Pressure Head

The addition of a designed fix of any type into the splitter box created an additional form of head loss. Depending on the system, and if there is excess energy that can be burned, added head loss may or may not be of concern. The upstream pressure head was measured for each designed fix in order to verify the amount of head that each fix added to the system.

When comparing the data from all the configurations, there were four design parameters that each individually affected the overall upstream head. The four parameters were: 1) the diameter of the holes in the vertical plates, 2) the porosity of the perforated section of the vertical plates, 3) the thickness of the vertical plate, and 4) the location of

the vertical plates in the box. In general, the vertical plates that produced the least amount of added head were thinner and positioned farther away from the upstream wall. The diameter of the holes did have an effect on the added head, with smaller holes creating a larger upstream head, but the plate thickness affected the upstream head more than the differing diameter sizes. The plates with a higher porosity of holes also produced less upstream head, but did not perform as well in the flow split. When comparing solely the location of the plates in the box, the plates positioned 6 in. away from the upstream wall nearly doubled the added upstream head that was produced when the plates were positioned 12 in. away from the wall. Overall, fix 8 and 8b, which are the same plate except for fix 8b had the top 5 rows of holes covered on the plate, added the least amount of upstream head to the system. Even though the diameter of the holes is smaller for these plates, the smaller plate thickness did more to decrease the upstream head than the smaller hole sizes did to increase the head.

For the plates that were installed in the box at 6 in. away from the upstream wall, a cap also was added at the top of the plate that forced the water to pass through the perforations. Without the use of the cap, water was able to pass over top of the plate, and at high flow rates, it splashed up and exited the box. The addition of the cap aided in preventing the loss of water from the box, but also was a big contributor to the increased upstream pressure head.

It is important to understand that the addition of vertical perforated plates into splitter boxes will change the conditions in the box. The effects of the perforated plates, especially the increased pressure head, should be considered before installation. If the

increases in pressure head are tolerable within the pipeline and the box, then the perforated plates are recommended to be installed for use. However, if the creation of additional head loss locations in the system will negatively affect the operation and performance, then the plates should not be used. When vertical plates are considered for installation, it should be ensured that the plates will not create too much head loss and result in a shortened supply of water to water users.

Splitter Box Field Data

The introduction of the vertical perforated plate into the prototype splitter box was effective in dissipating the incoming energy in the flow and forcing the water profile over the weir to be more uniform. Figures 20 and 21 show the prototype splitter box before and after the vertical perforated plate was installed, respectively. The plate was not perfectly positioned due to the difficulty of installing the plate when high flow rates were passing through the box. Permanent installations of vertical plates, similar to the one installed in the field, should take place when lower flows or no flow is passing through the box. But the improvements after the plate was installed were significant and consistent with those found in this study. Also, the visual results of the installation of the vertical plate were met with satisfaction from the irrigation board and local farmers who use the irrigation water.



Figure 20. Prototype splitter box before vertical plate was installed.



Figure 21. Prototype splitter box after vertical plate was installed.

The data that was logged in the field occurred when the plate was installed in the box. There was no data taken when the plate was removed from the box, and therefore, the data that was logged could not be compared to the baseline values to verify the improvements. However, the installed plate appeared to improve the flow conditions in the box visually. Because of the results and improvements that were seen in the model study, it is assumed that the same positive results would be seen if more data had been collected from the prototype box. The small amount of data that was collected from the prototype splitter box showed that the perforated plate produced a flow split that was in the range of what it should have been when using the ultrasonic flow meters. The results became even more accurate when the parshall flume, which was located upstream of the box, was used to measure the flow going into the splitter box. These results showed that the installation of the vertical perforated plates were effective and performed as desired.

CHAPTER VI

CONCLUSIONS

Compact splitter boxes can be very effective at evenly distributing the incoming flow when operated at low flow rates. However, if higher flow rates are required to pass through the boxes, the flow becomes turbulent and non-uniform. In order to improve the hydraulic conditions in boxes with high flows, for example at the beginning of an irrigation system with many water users, some type of design should be installed to dissipate energy. Vertical perforated steel plates are very effective at dissipating excess energy and uniformly distributing the flow so that it can be accurately split.

Vertical plates are a feasible option because of their potential to be installed and removed when necessary for cleaning and maintenance of the box. If a set of guides can be installed on the walls of a box as part of a structural supporting frame, the plates will slide up and down in a set location. It is recommended to install the plates at low flow rates or before water is flowing if possible. At high flow rates, installation is more difficult because of the high momentum forces from the water that will resist such an installation.

The perforated portion of the plate should be approximately 40% porous. Increasing the porosity of the plate beyond this value decreased the aesthetic quality of the water surface in the box. The vertical perforated plates should be as thin as possible to decrease the added head, but should be thick enough so that they are sturdy and durable.

The best-performing vertical perforated plates were designed fixes 6 and 8 and designs with small modifications to these plates, like fixes 6b and 8b. These designs had

1 in. and 0.5 in. diameter perforations, respectively. These designs were the most capable of providing good flow split data while also improving the visual quality of the water surface.

In many situations, splitter boxes are already installed in an irrigation system when issues such as those described in this thesis are discovered. The main hydraulic issues arise because of the inadequate distance upstream of the weir. In general, the approach conditions that are consistent with the upstream requirements to achieve uniform and steady flow as recommended by Clemmens et al. (2001), are not feasible for a pressurized irrigation network with splitter boxes. However, it was determined by this study that extending the length of the splitter box and installing a vertical plate improves the uniformity of the flow within the box. It is recommended that splitter boxes be designed to have a maximum amount of distance upstream from the weir within the box and a vertical perforated plate to quickly dissipate energy and evenly distribute the flow.

Another successful test that greatly improved the flow conditions in the extended box was the addition of a 45 deg. ramp. Configuration 4, which included the ramp, provided the best overall results during this study when designed fixes 6b and 8b were installed. The combination of configuration 4 and these designed fixes resulted in a very smooth water surface, with minimal ripples, and good data. The data proved that the same percentage of flow was being split regardless of the flow rate passing through the box. The ramp was installed solely at a 45 deg. angle for testing. It is possible that other angles could provide better results. If a ramp is implemented in a splitter box at an angle

other than 45 deg., it is recommended that further research and testing be done to ensure satisfactory results.

The data and research presented here will help engineers and farmers alike who are seeking to design or fix poorly-performing flow splitter boxes. The ideas developed in this study have potential to be used in other applications as well where flow distribution and flow uniformity is desired. If the designs and configurations from this research are used in practice, they should be scaled appropriately to provide the same results as were found in this study.

REFERENCES

- American Society of Mechanical Engineers (ASME). (2006), *Test Uncertainty (ASME PTC 19.1-2005)*, New York, NY.
- Clemmens, A. J.; Wahl T. L.; Bos, M. G., and Replogle, J. A. (2001). "Water Measurement with Flumes and Weirs." ILRI, Publication 58, Wageningen, The Netherlands.
- Finnemore, E., and Franzini, J. (2002). "Similitude and Dimensional Analysis." *Fluid mechanics with engineering applications*, Tenth Ed. McGraw-Hill, New York, 232-254.
- Johnson, M. (2000). "Discharge coefficient analysis for flat-topped and sharp-crested weirs." *J. Irrig. Sci.*, 19(3): 133-137.
- Palde, U.J. (1972). "Hydraulic Laboratory Studies of a 4-foot-wide Weir Box Turnout Structure for Irrigation Use" REC-ERC-72-31, United States Bureau of Reclamation, Denver, CO.
- Peterka, A. J. (1984). "Stilling Basin for Pipe or Open Channel Outlets (Basin VI)." *Engineering Monograph No. 25: Hydraulic Design of Stilling Basins and Energy Dissipators*. United States Bureau of Reclamation, Denver, CO, 81-89.
- Simmons, W.P. and Case, W. C. (1954). "Hydraulic Model Studies of Small Weir Box Turnout Structures for General Irrigation Use" HYD-396, United States Bureau of Reclamation, Denver, CO.

APPENDICES

Appendix A: Scale Ratio Derivations

Froude Number

$$F = \frac{V}{\sqrt{g \cdot Y}}$$

$$\frac{V_p}{\sqrt{g_p \cdot Y_p}} = \frac{V_m}{\sqrt{g_m \cdot Y_m}} \quad \text{in order to achieve dynamic similarity}$$

Velocity Ratio

Combine V_p and V_m to form the Velocity Scale Ratio

$$\frac{V_p}{V_m} = \frac{\sqrt{g_p \cdot Y_p}}{\sqrt{g_m \cdot Y_m}} \quad \text{and} \quad g_p = g_m \quad \text{so}$$

$$\frac{V_p}{V_m} = \frac{\sqrt{Y_p}}{\sqrt{Y_m}} \quad \text{and} \quad \frac{Y_p}{Y_m} = Y_r \quad \text{and} \quad \frac{V_p}{V_m} = V_r \quad \text{so}$$

$$V_r = \sqrt{Y_r} \quad \text{and} \quad Y = L \quad \text{therefore} \quad Y_r = L_r \quad \text{so}$$

$$V_r = \sqrt{L_r}$$

Flow Ratio

Continuity gives that $Q = V \cdot A$

The units of an area are L^2 therefore L_r^2 corresponds to area in the continuity equation

$$Q = V \cdot A \quad \text{and} \quad A = L_r^2 \quad \text{so}$$

$$Q_r = V_r \cdot L_r^2 \quad \text{and} \quad V_r = \sqrt{L_r} \quad \text{from above so}$$

$$Q_r = \sqrt{L_r} \cdot L_r^2 \quad \text{and} \quad \sqrt{L_r} = L_r^{0.5} \quad \text{so}$$

$$Q_r = L_r^{0.5} \cdot L_r^2 \quad \text{and simplifying gives}$$

$$Q_r = L_r^{2.5}$$

Head Ratio

Pressure head units are the same as length units and therefore

$$H_r = L_r$$

Figure 22. Scale Ratio Derivations.

Appendix B: Drawings of Tested Configurations and Designed Fixes

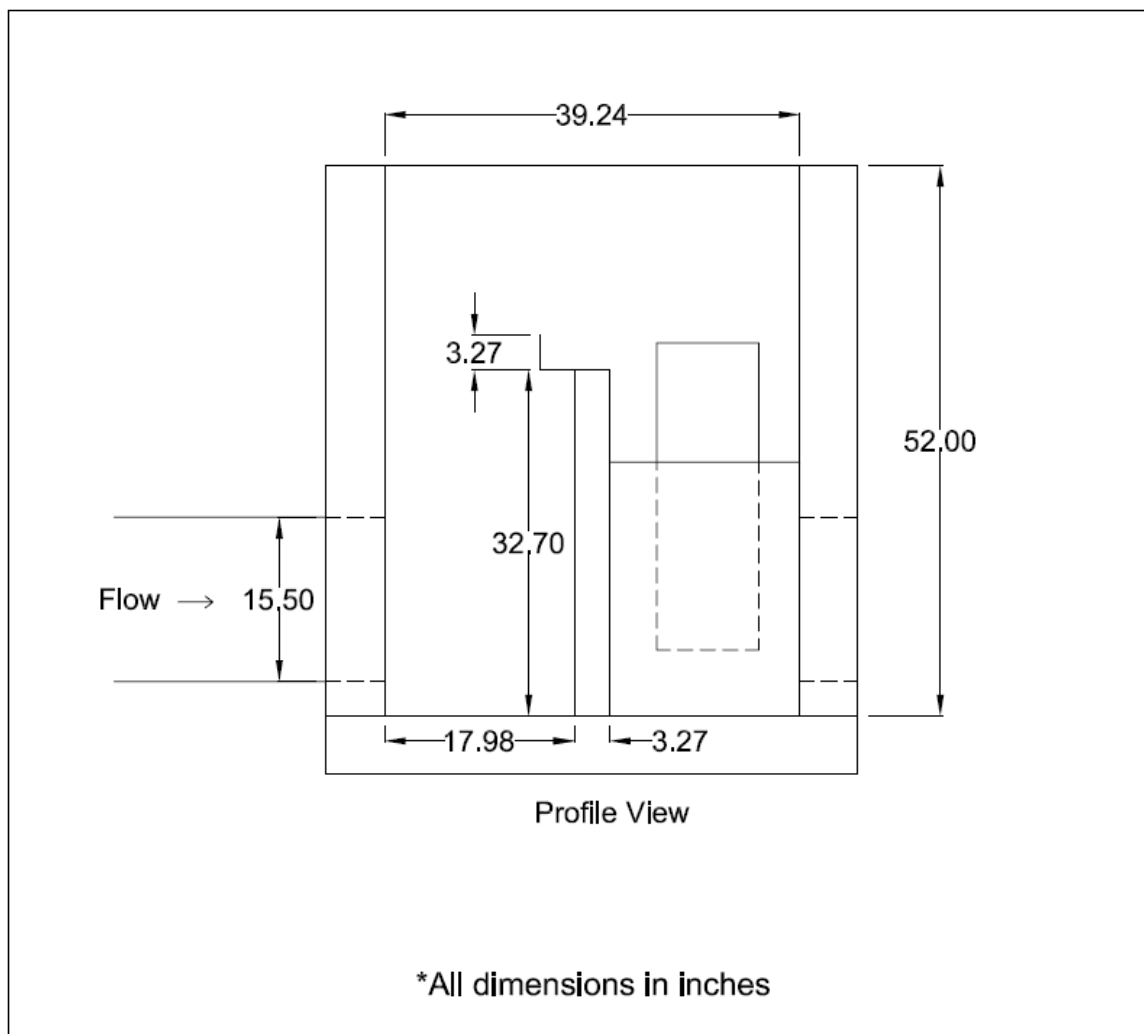

Figure 23. Drawing of Config. 1-Baseline.

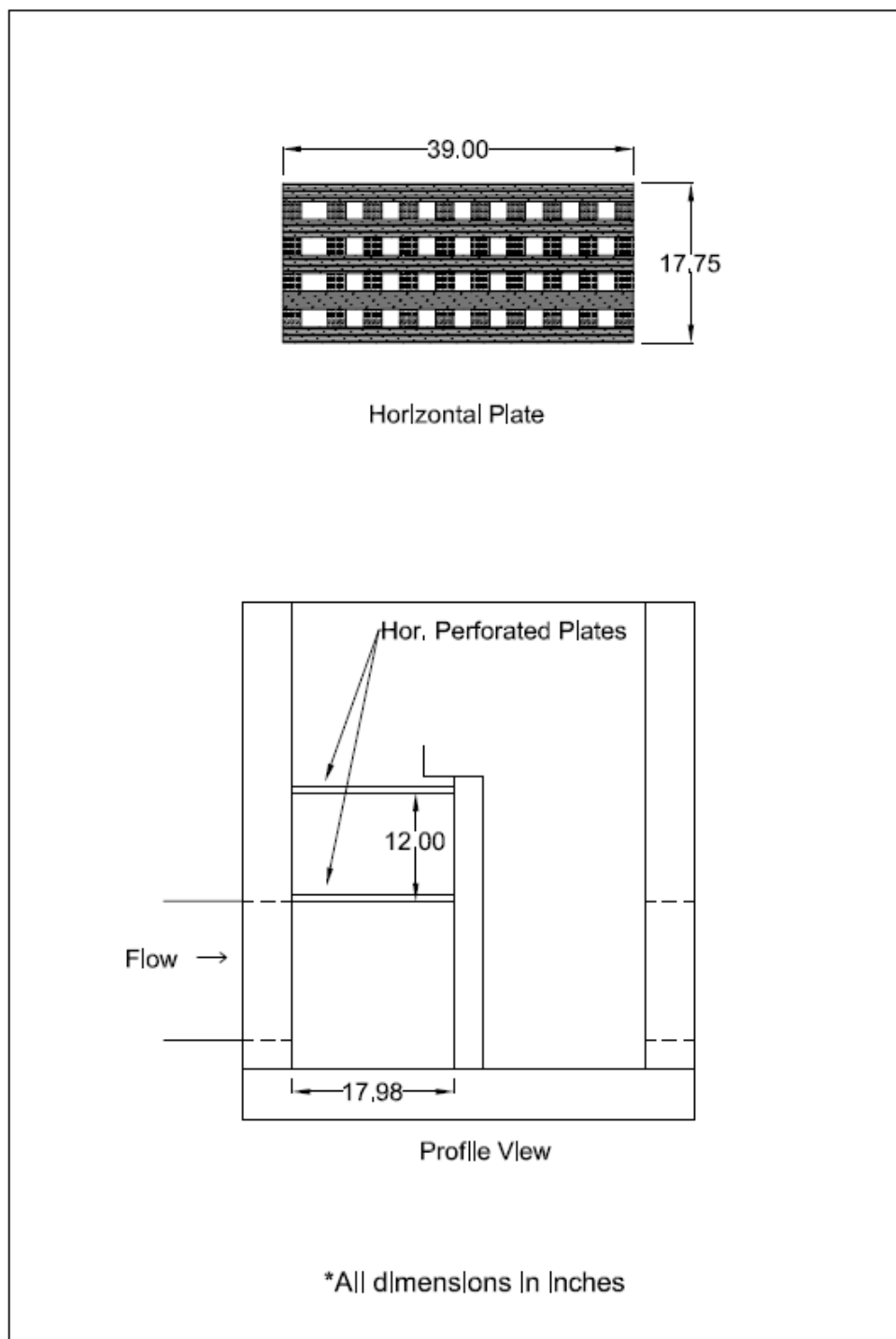

Figure 24. Drawing of Config. 1-1.

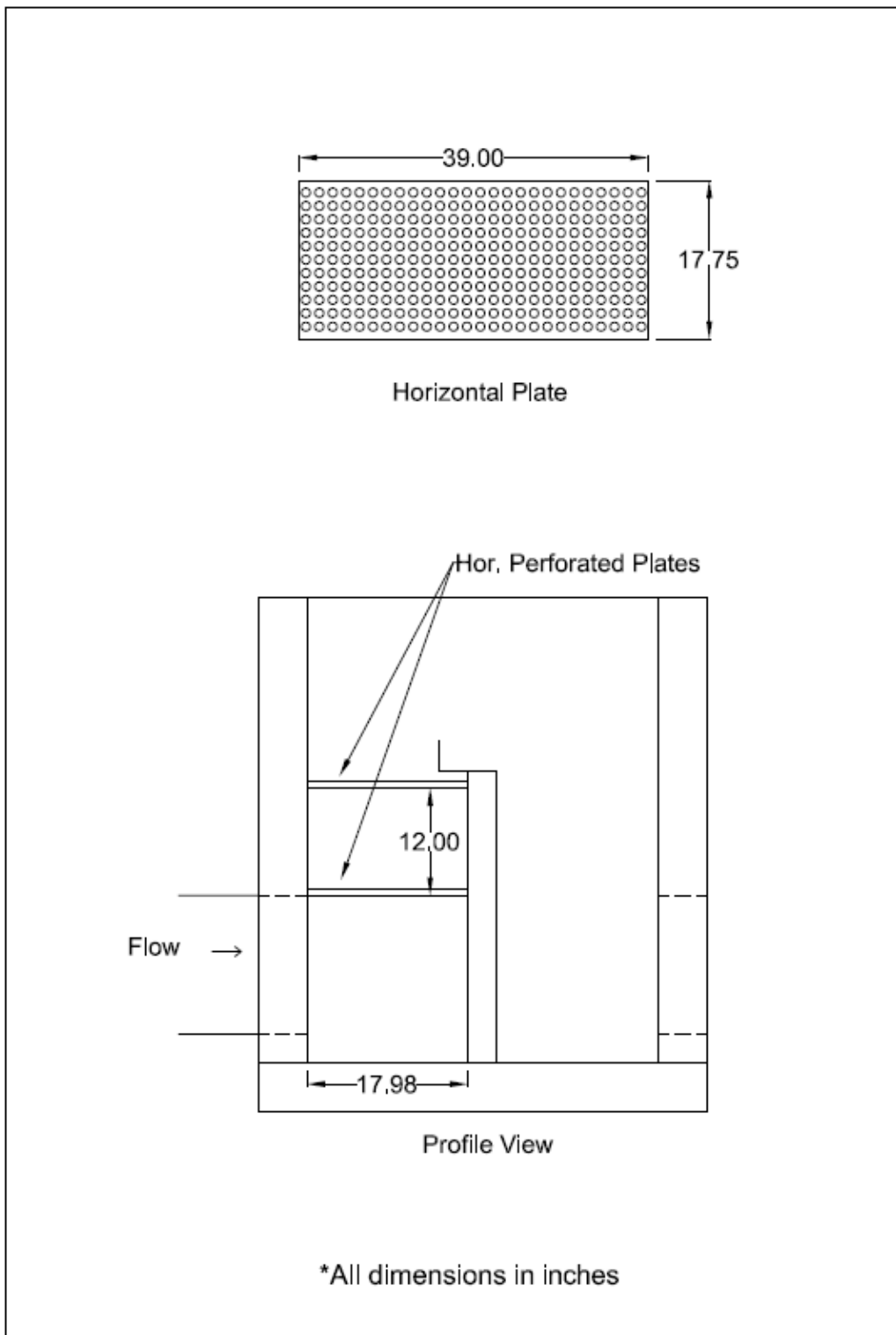

Figure 25. Drawing of Config. 1-2.

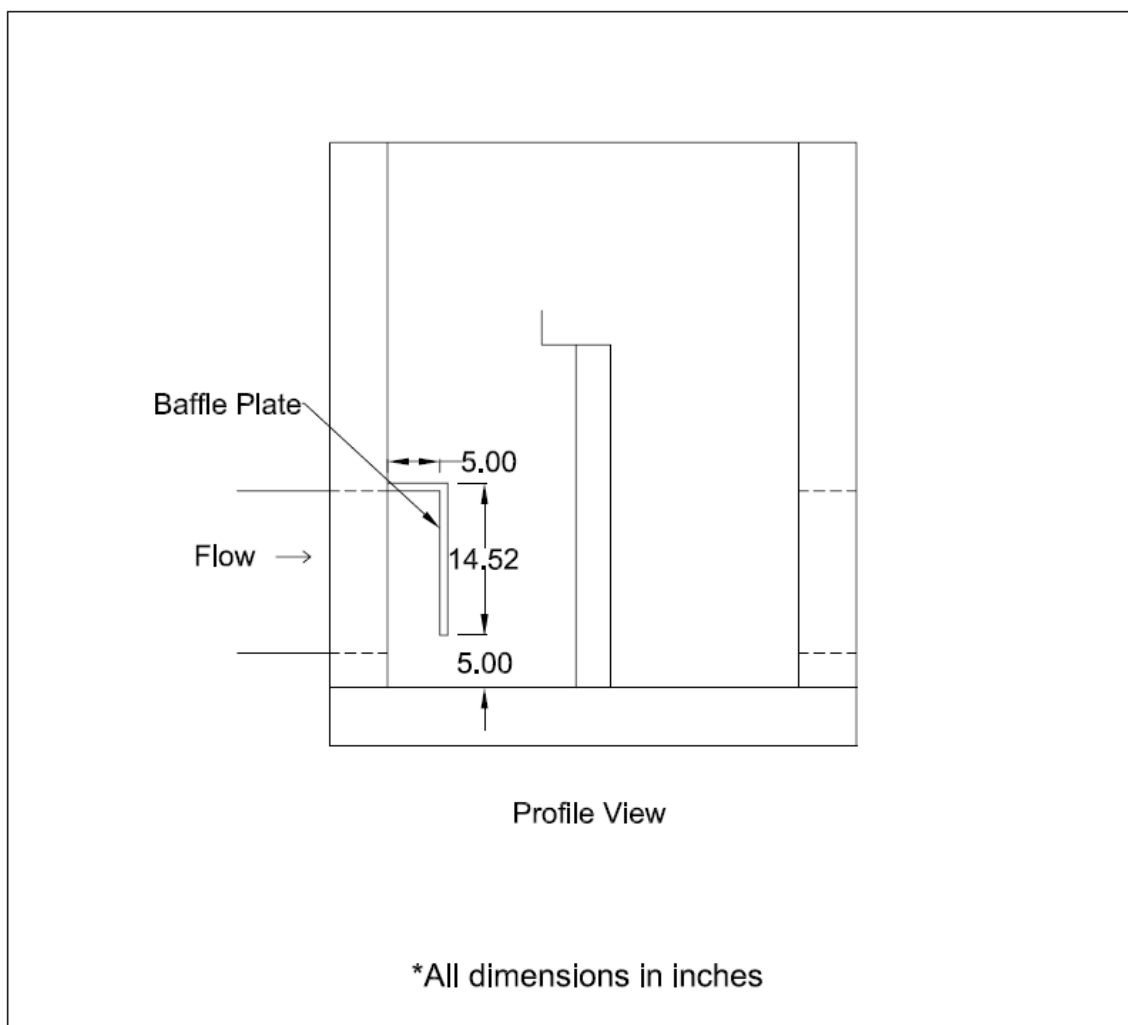

Figure 26. Drawing of Config. 1-3.

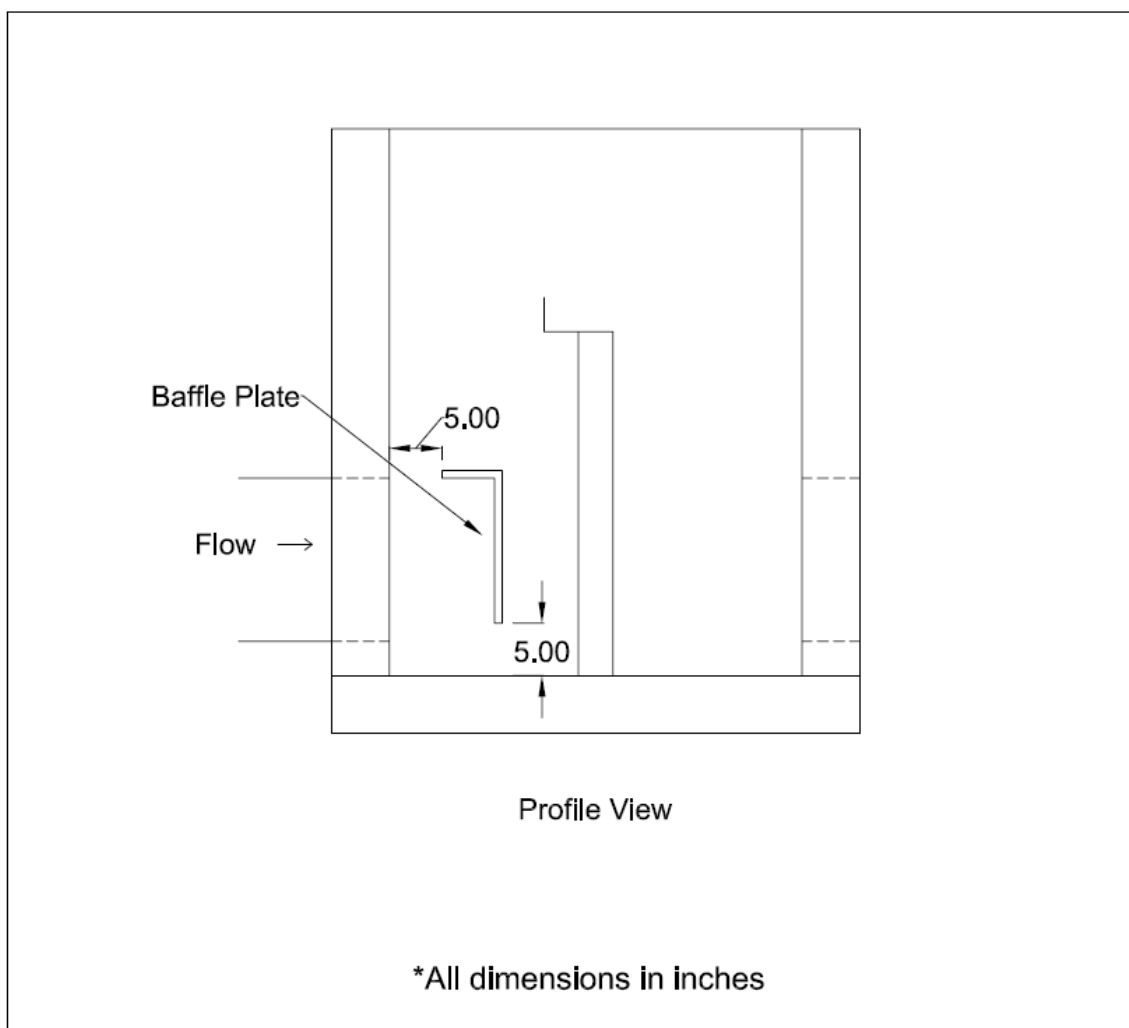

Figure 27. Drawing of Config. 1-3a.

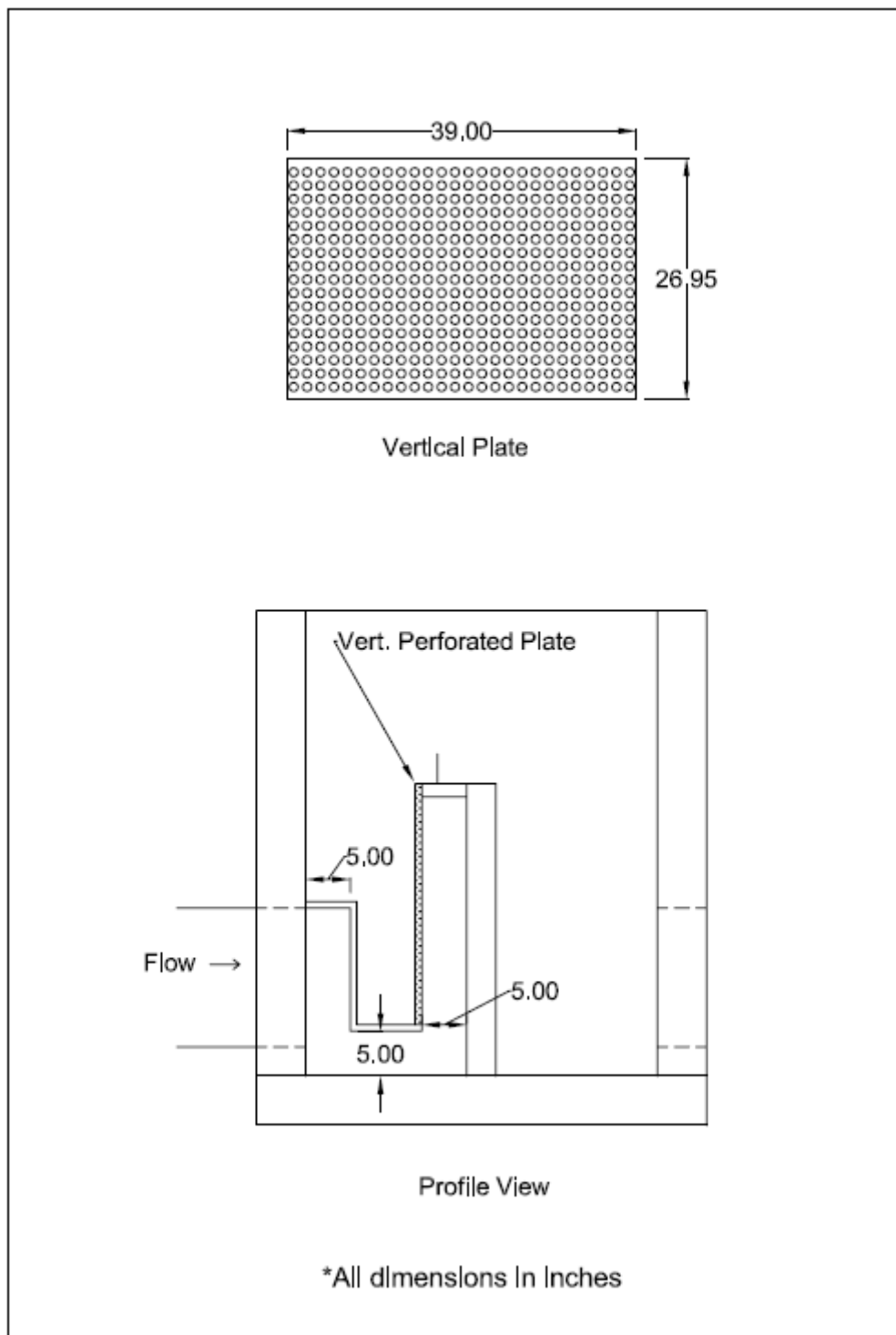

Figure 28. Drawing of Config. 1-4.

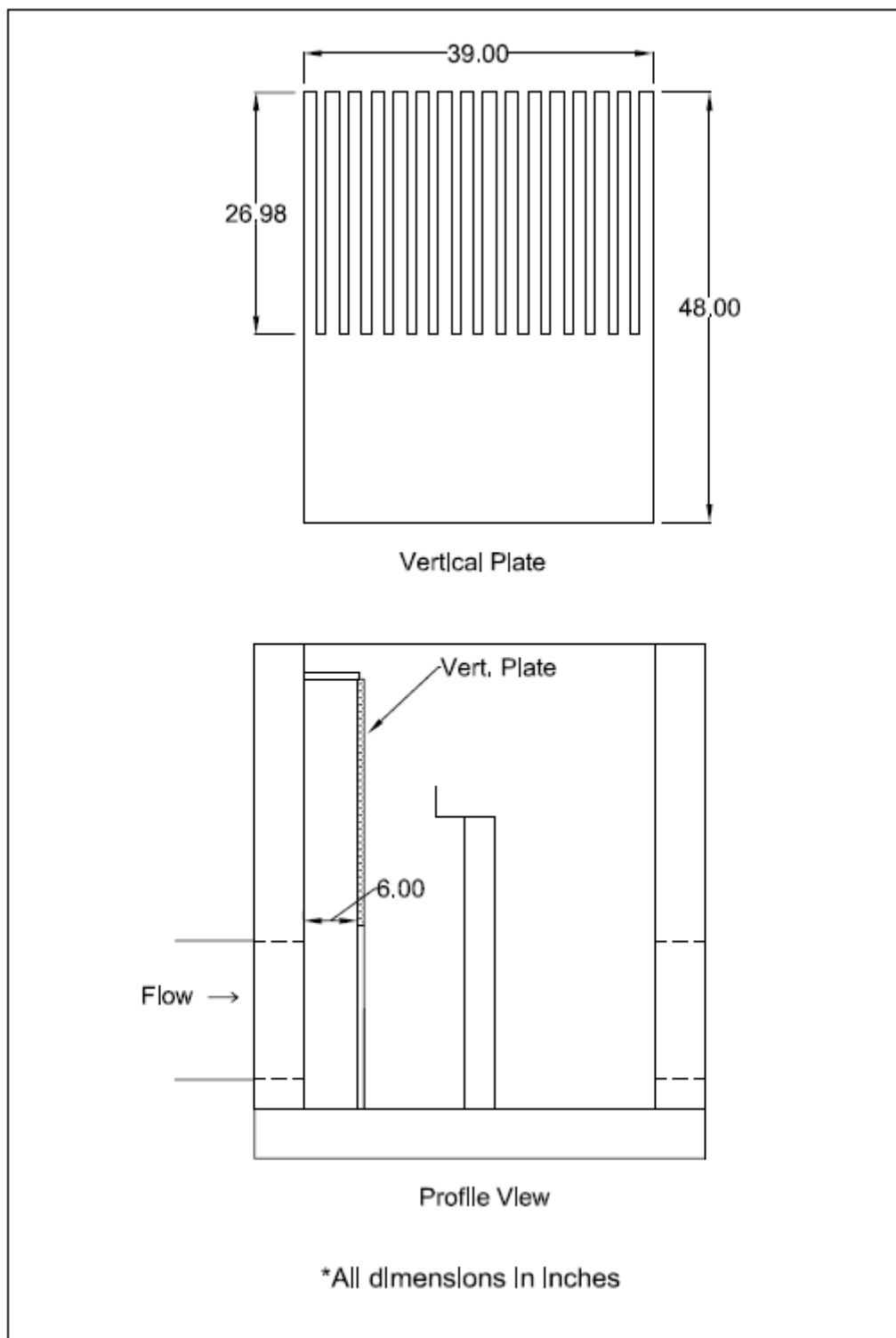

Figure 29. Drawing of Config. 1-5.

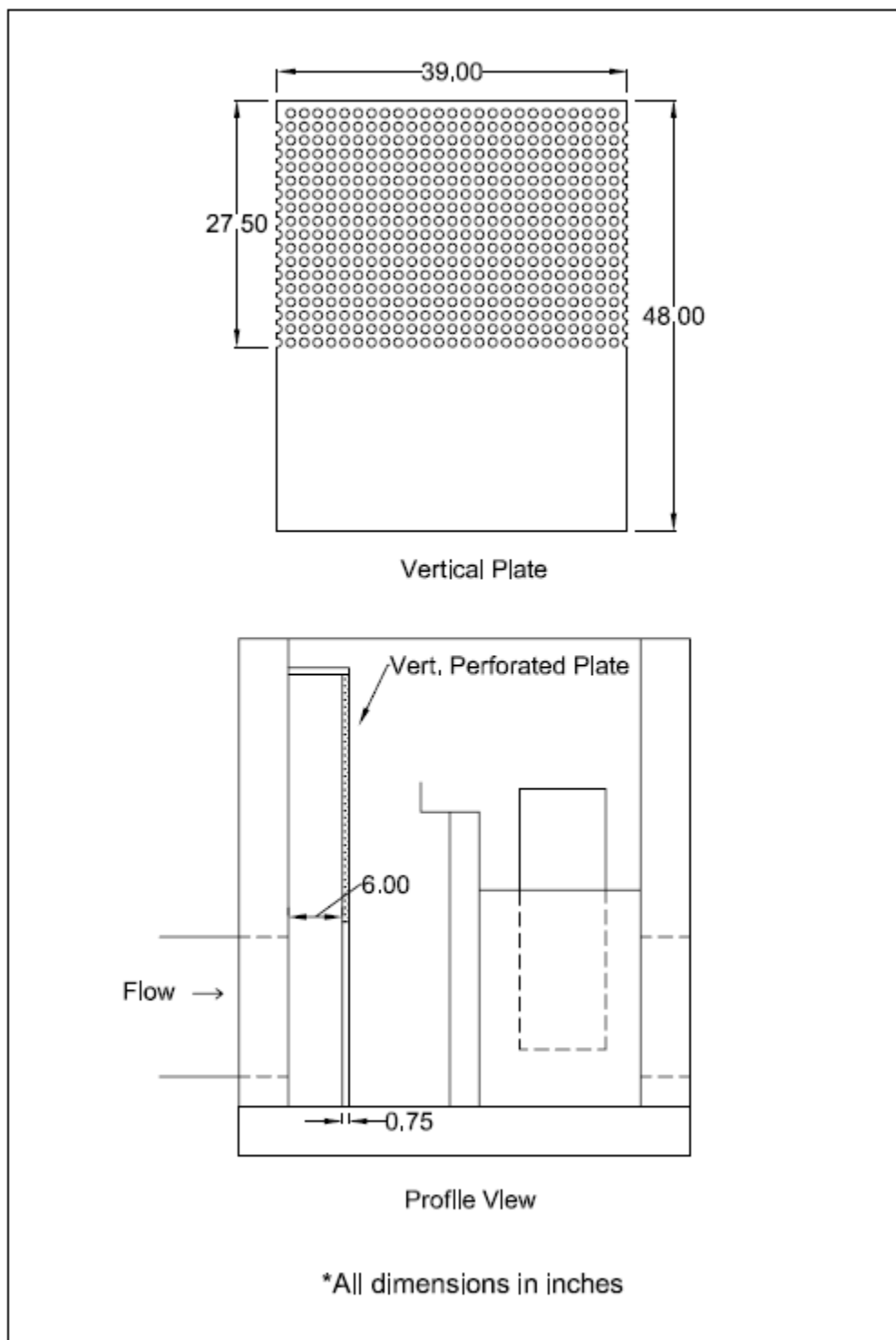

Figure 30. Drawing of Config. 1-6.

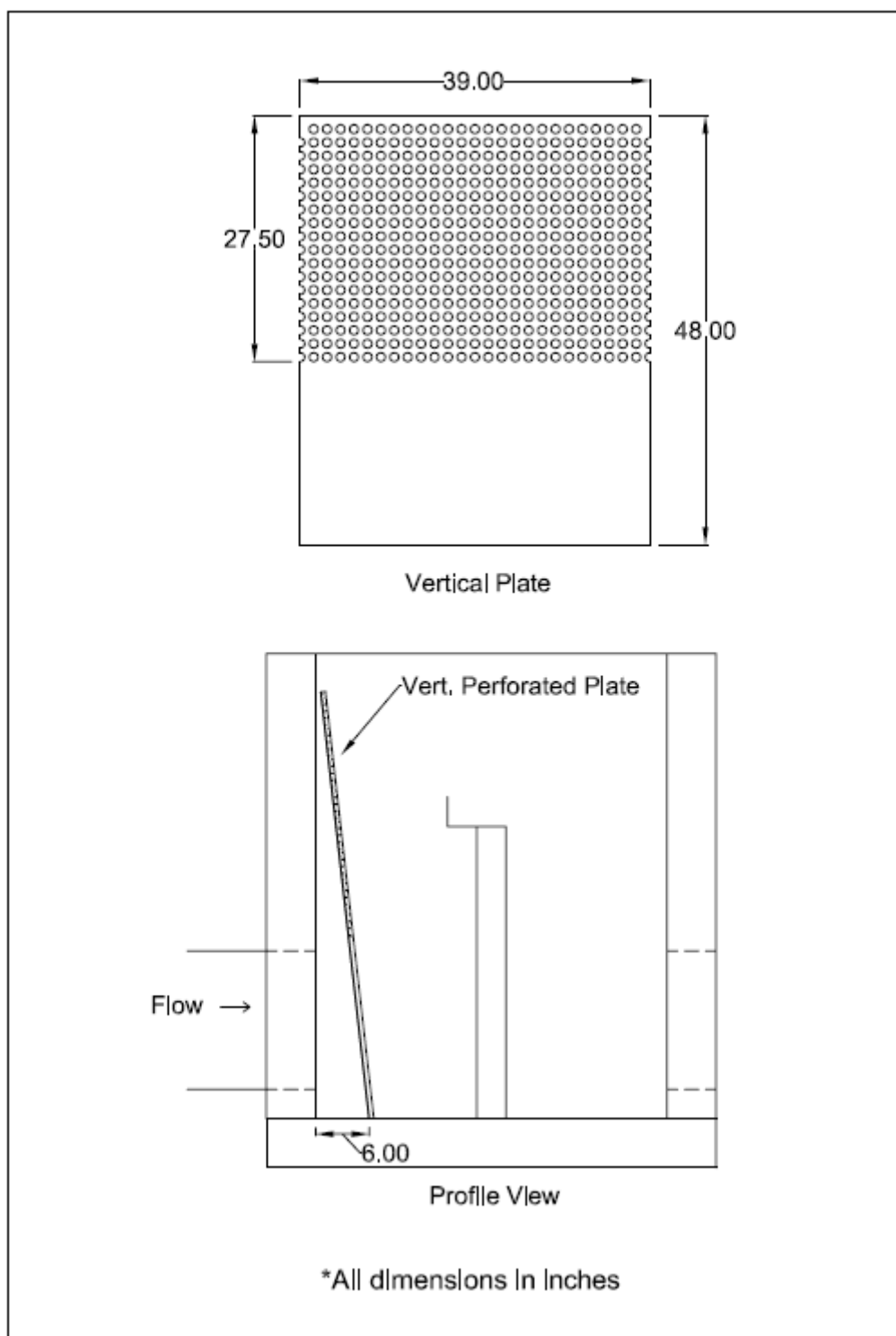

Figure 31. Drawing of Config. 1-6a.

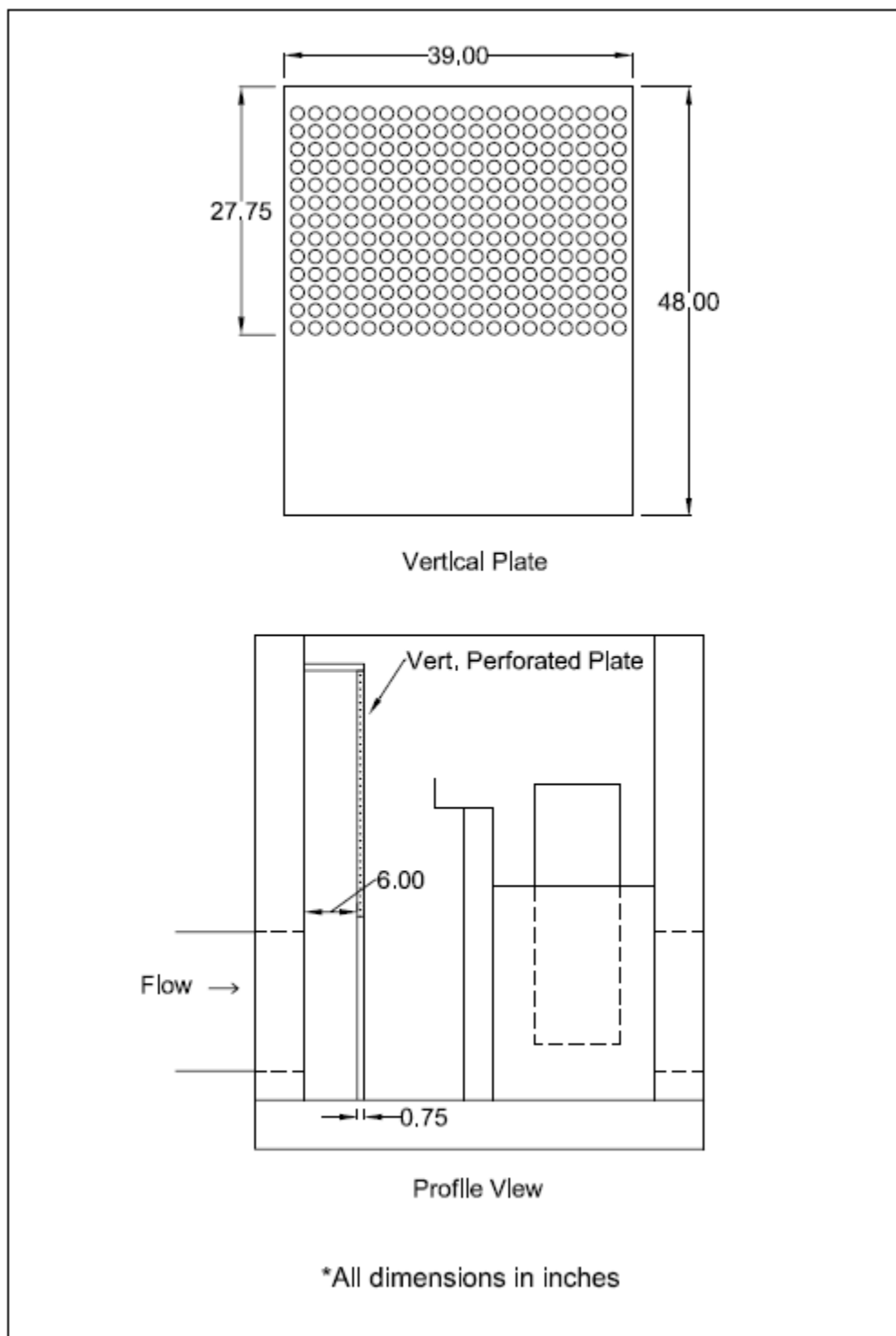

Figure 32. Drawing of Config. 1-7.

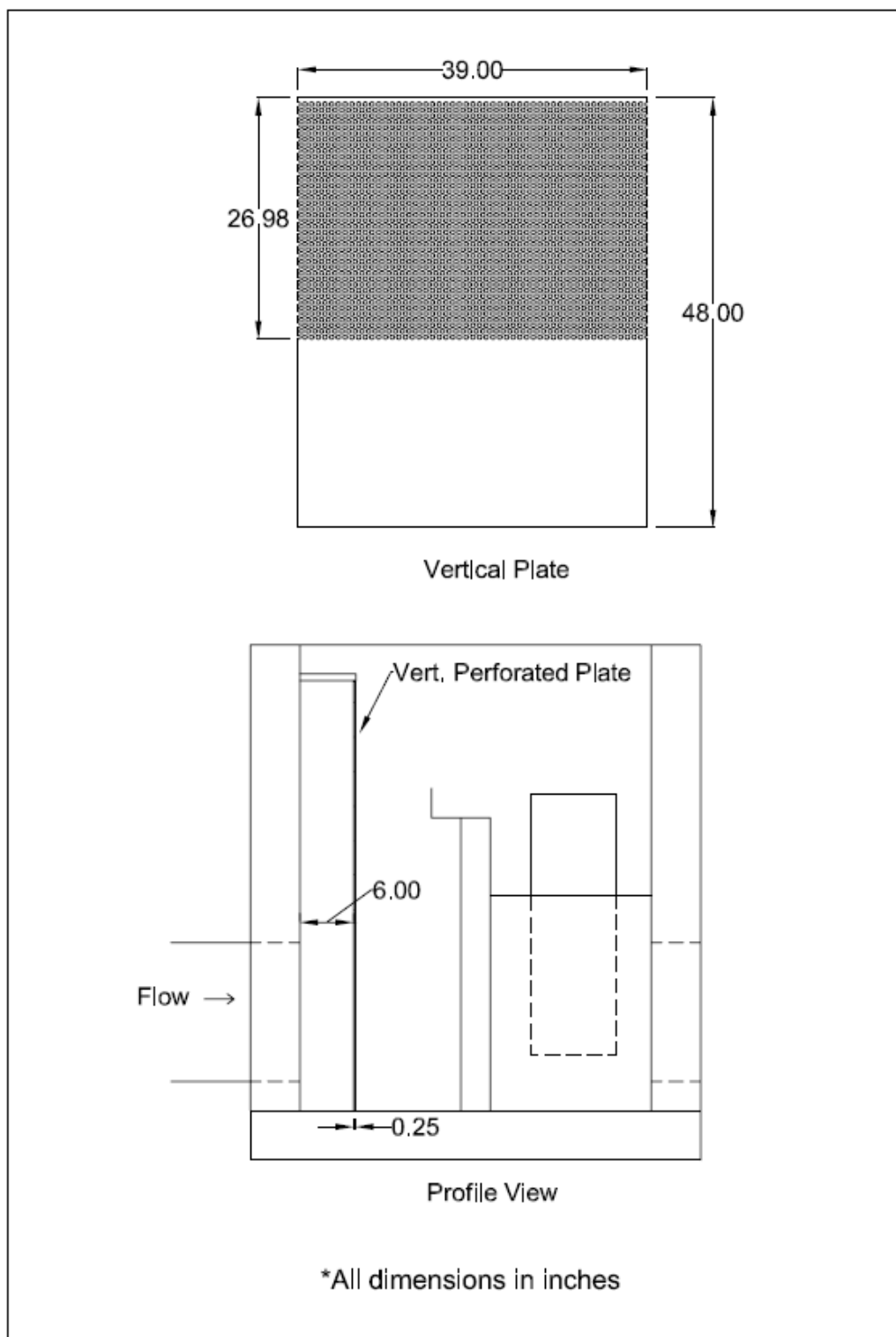

Figure 33. Drawing of Config. 1-8.

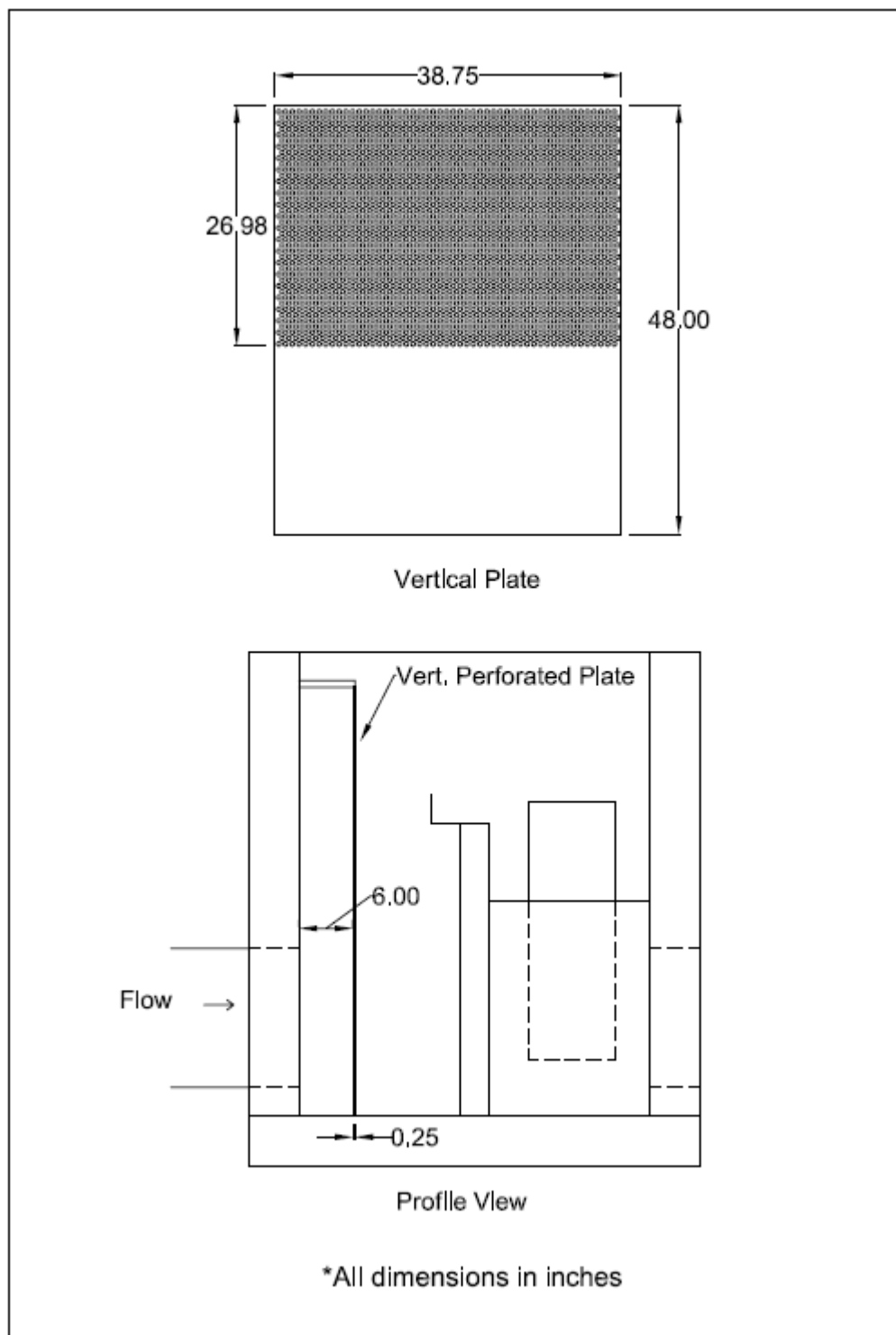

Figure 34. Drawing of Config. 1-8a.

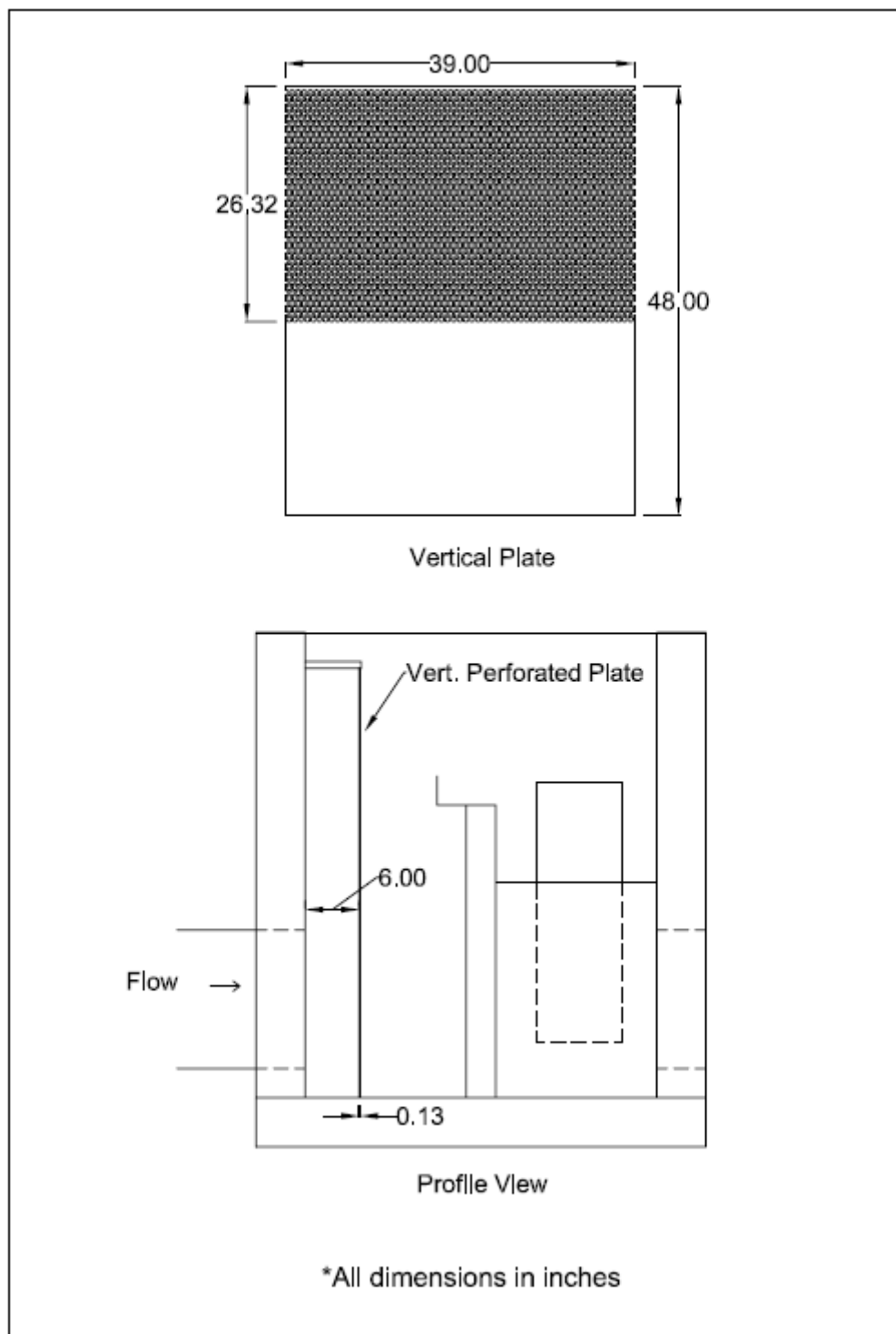

Figure 35. Drawing of Config. 1-9.

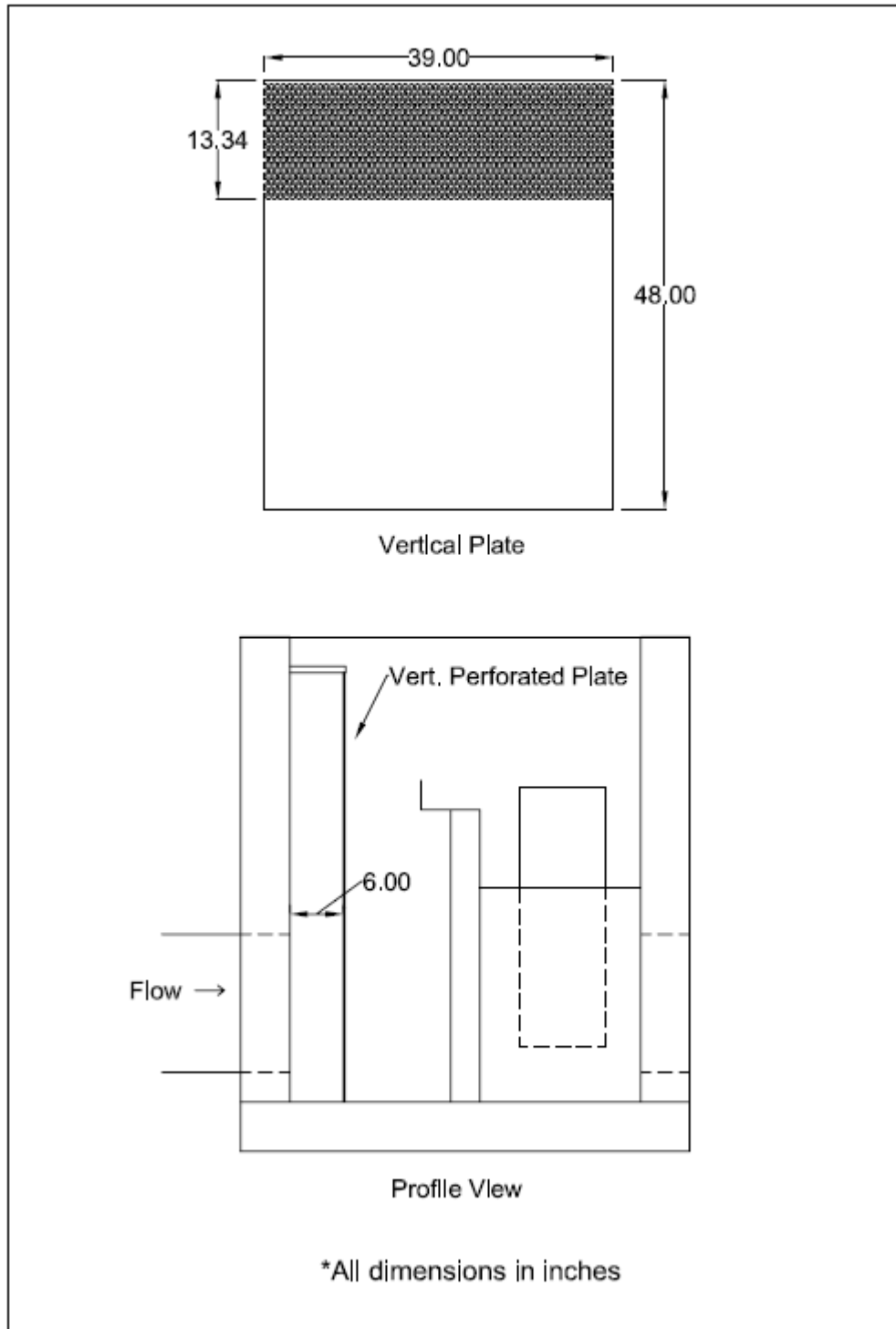

Figure 36. Drawing of Config. 1-9a.

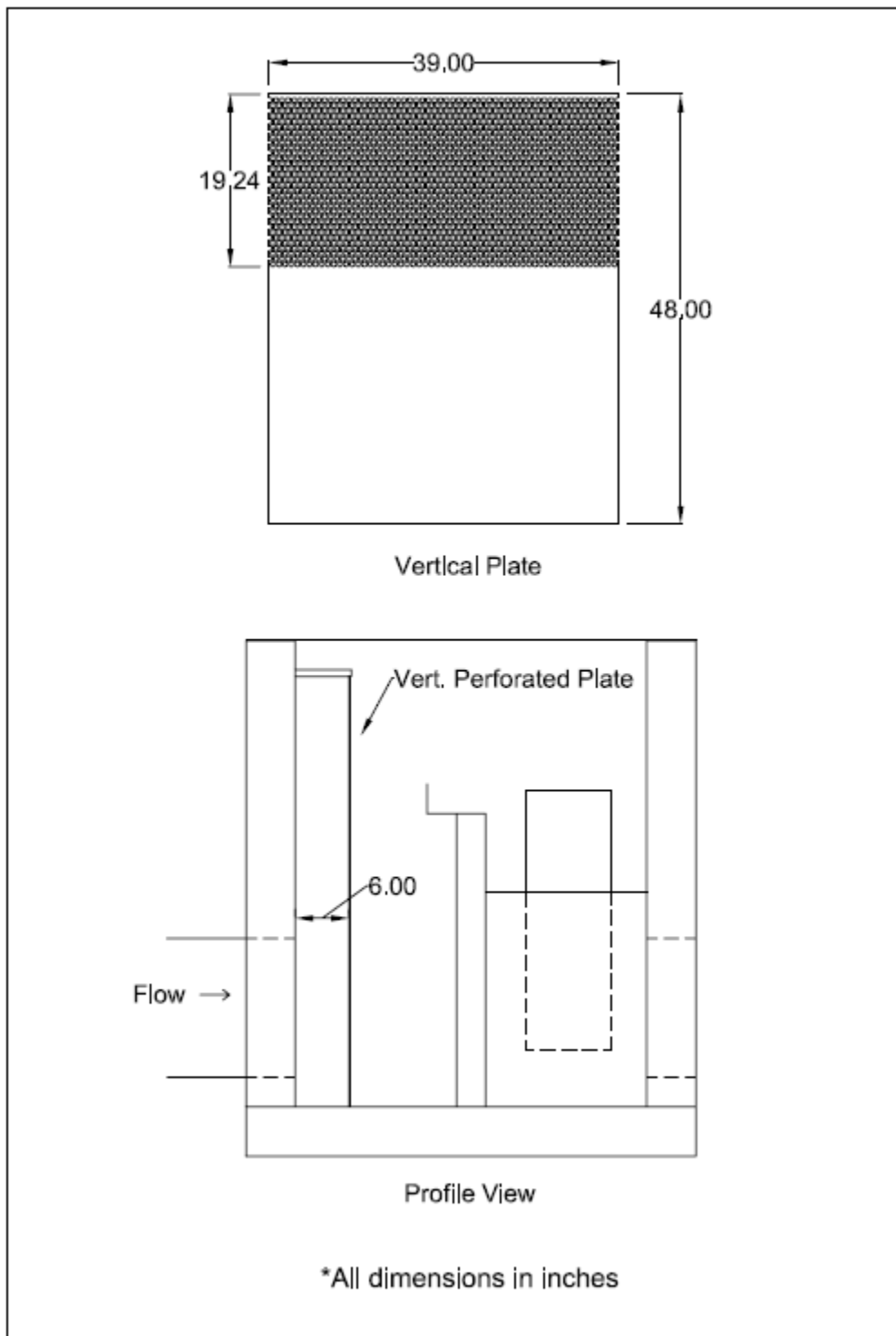

Figure 37. Drawing of Config. 1-9b.

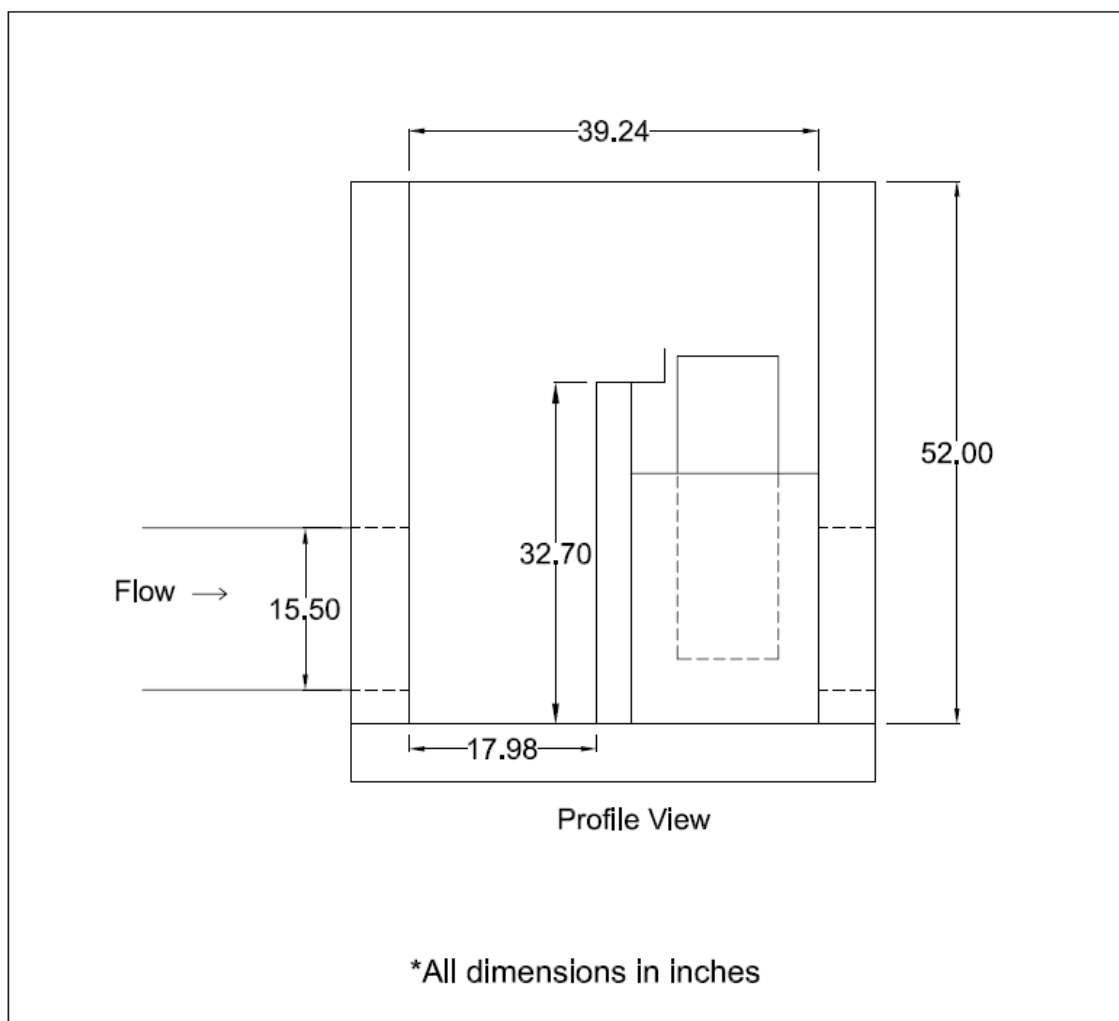

Figure 38. Drawing of Config. 2-Baseline.

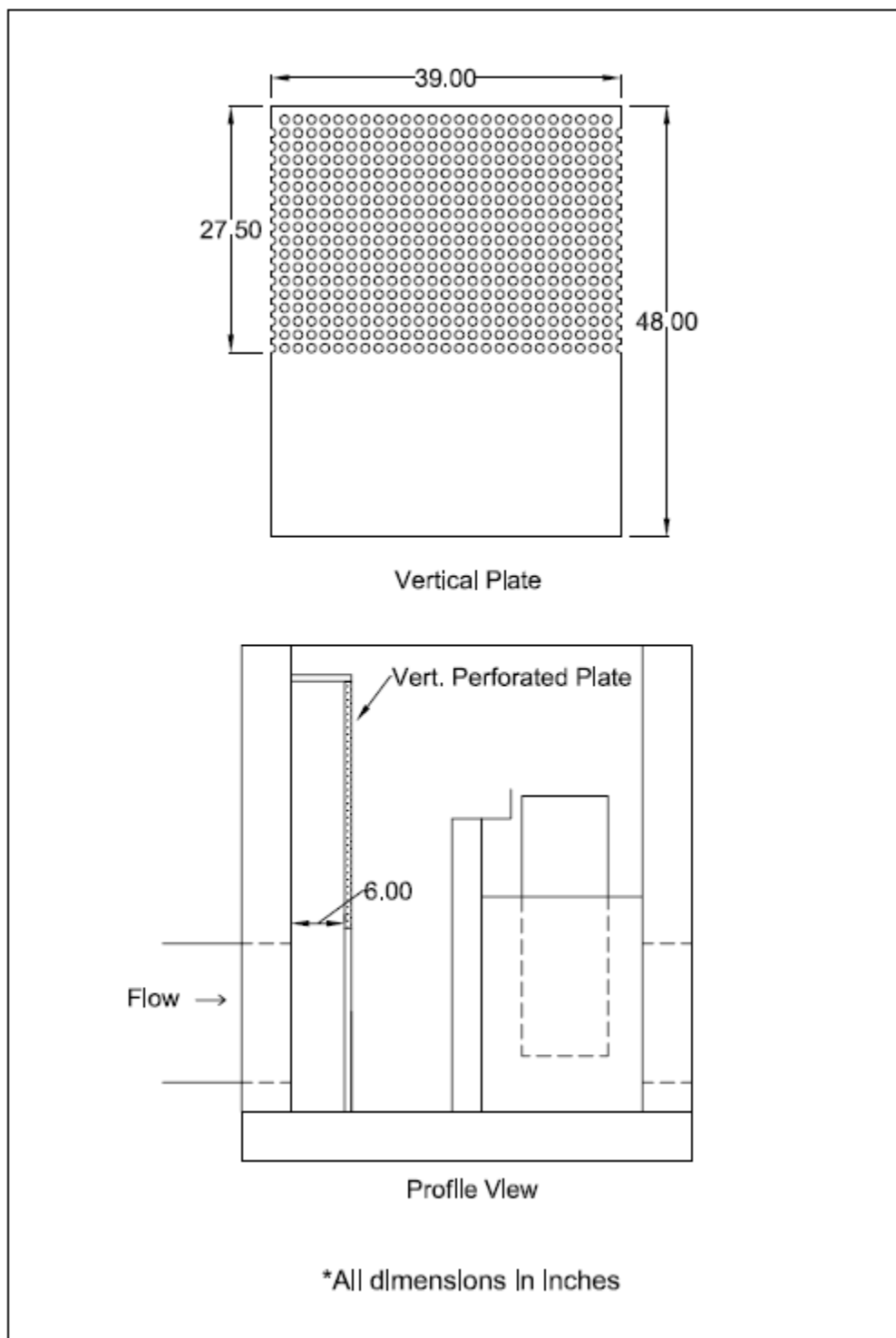

Figure 39. Drawing of Config. 2-6.

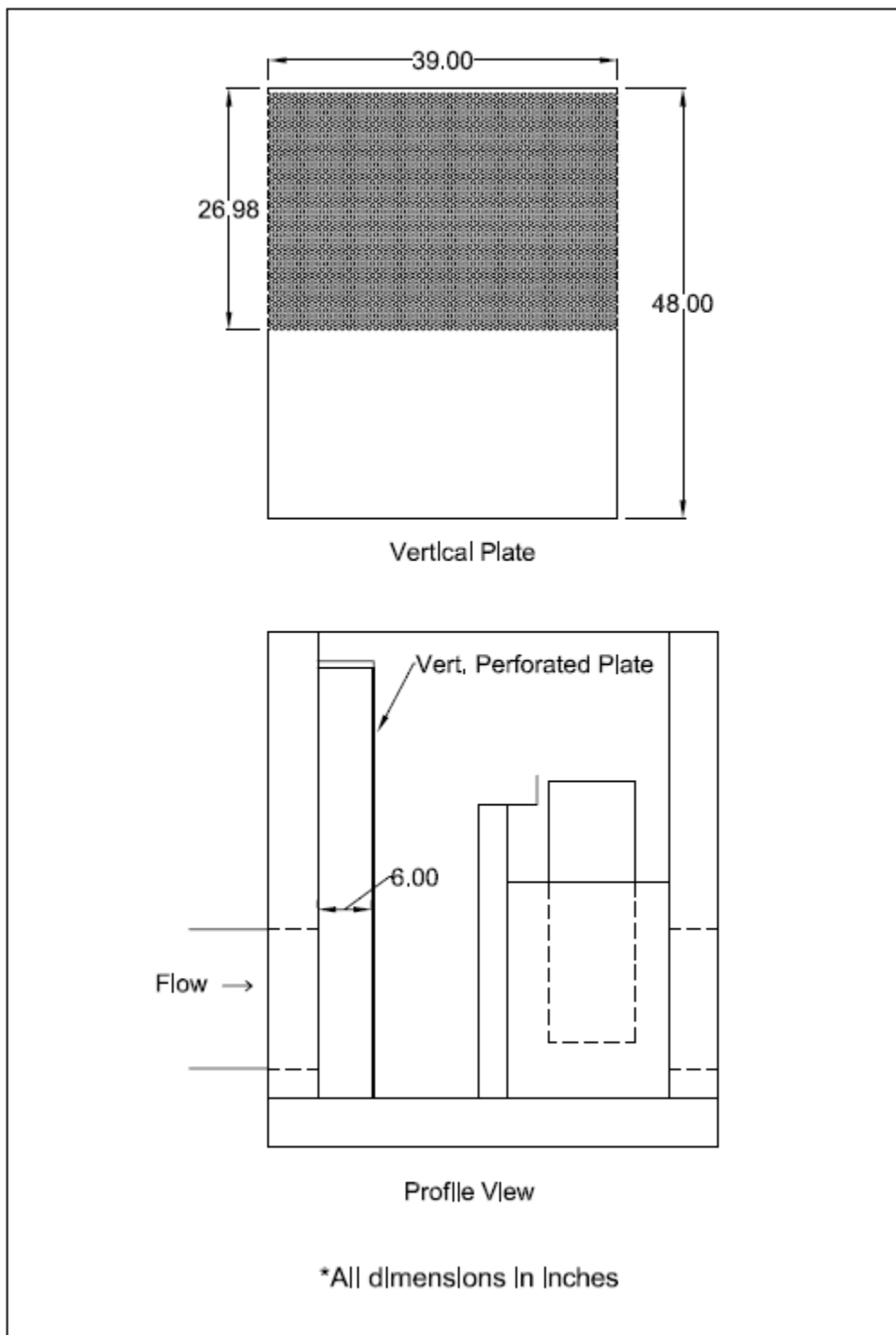

Figure 40. Drawing of Config. 2-8.

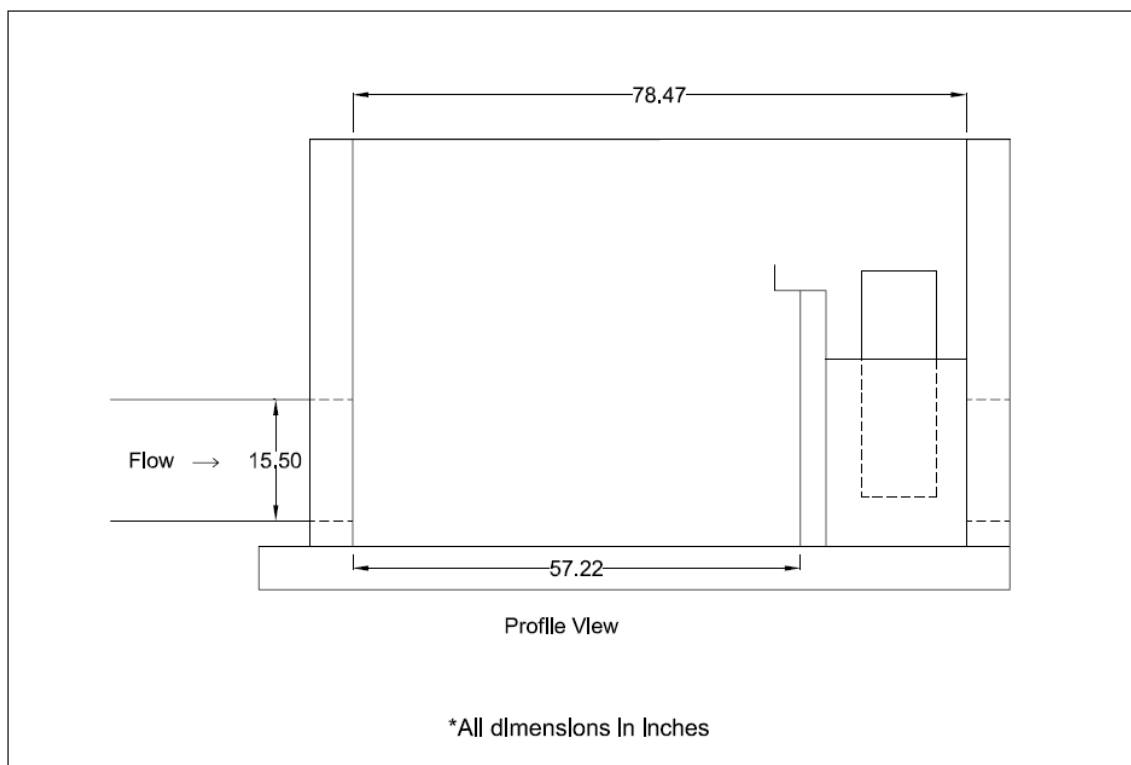

Figure 41. Drawing of Config. 3-Baseline.

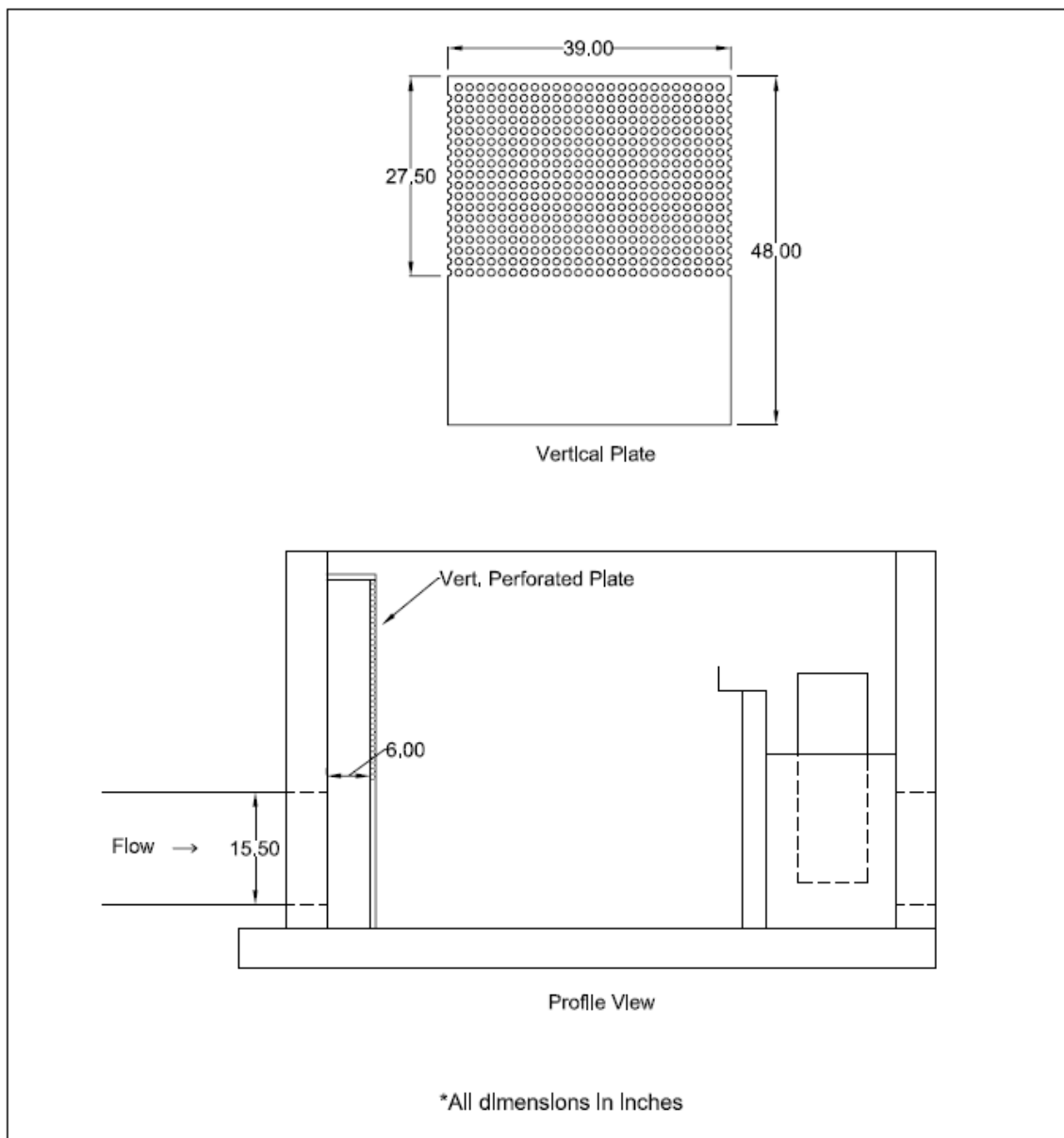

Figure 42. Drawing of Config. 3-6.

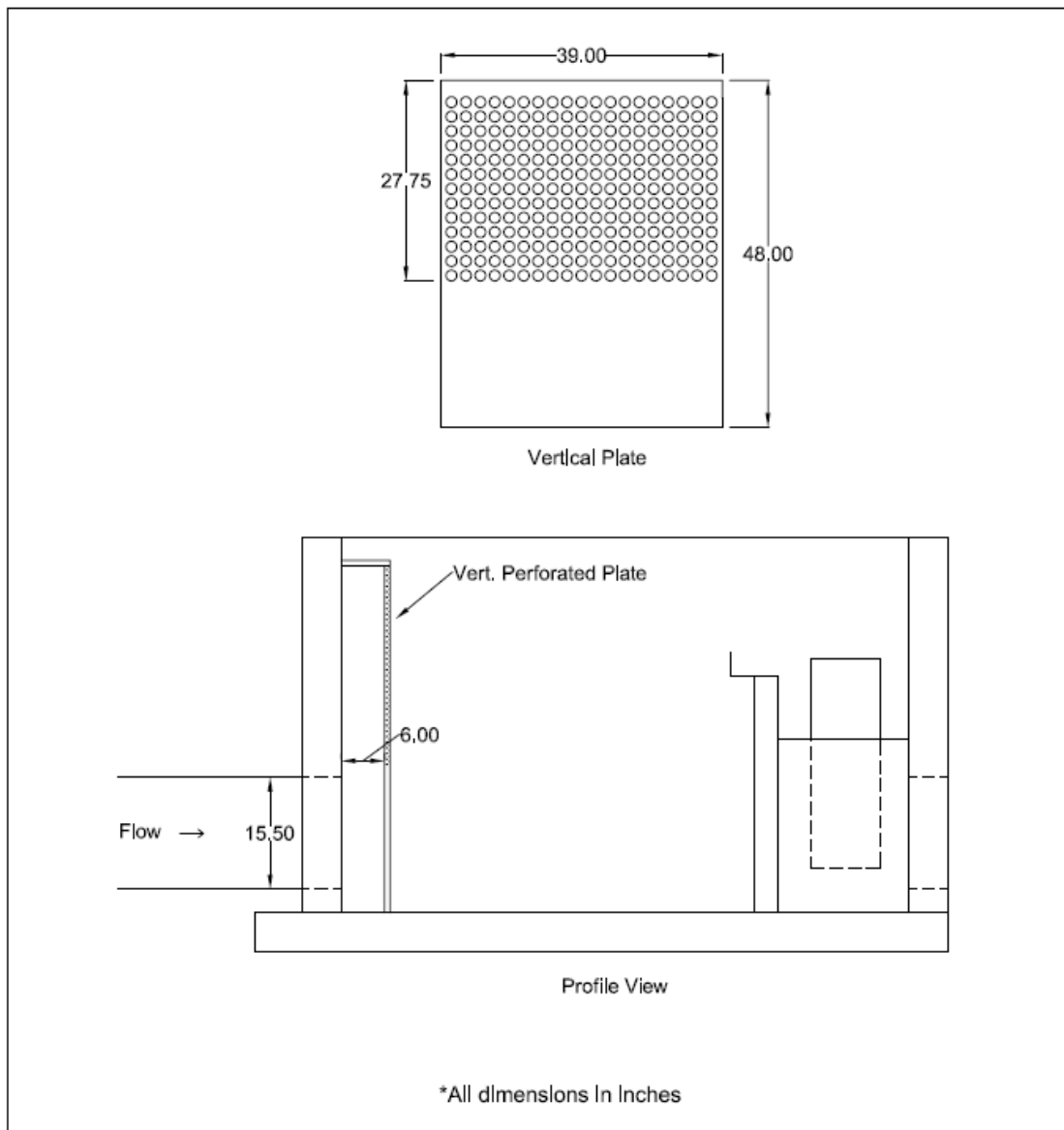

Figure 43. Drawing of Config. 3-7.

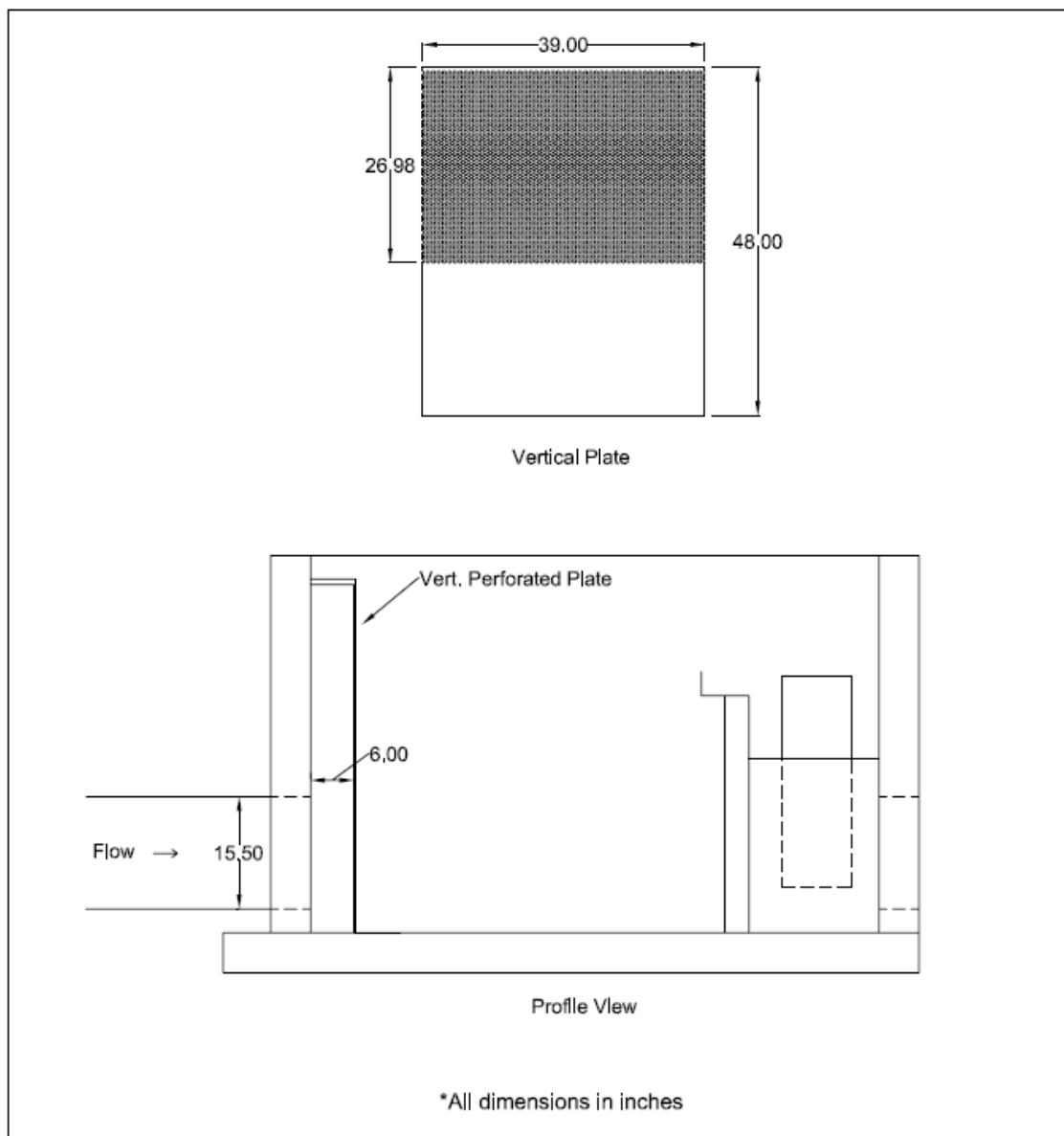

Figure 44. Drawing of Config. 3-8.

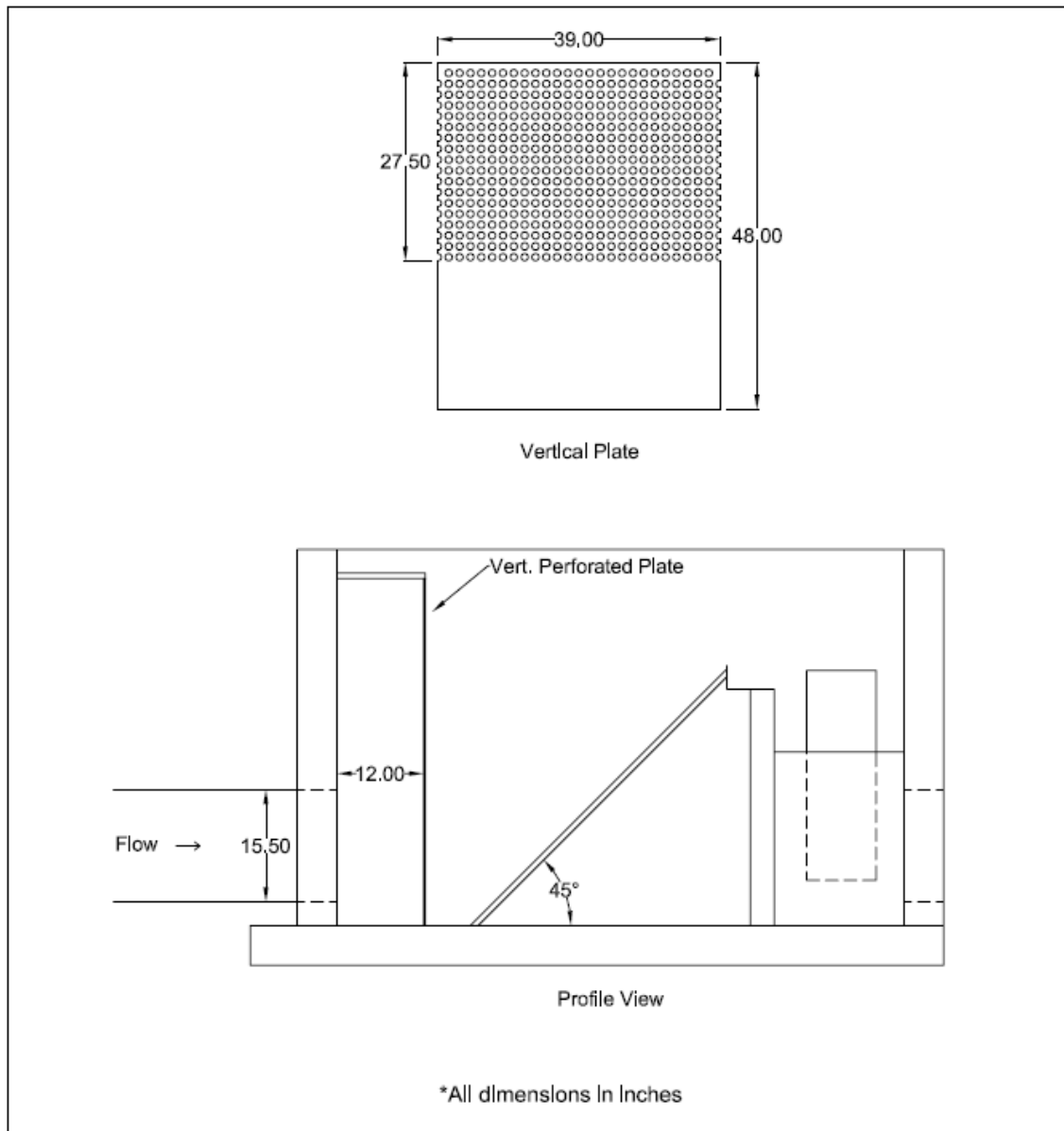

Figure 45. Drawing of Config. 4-6.

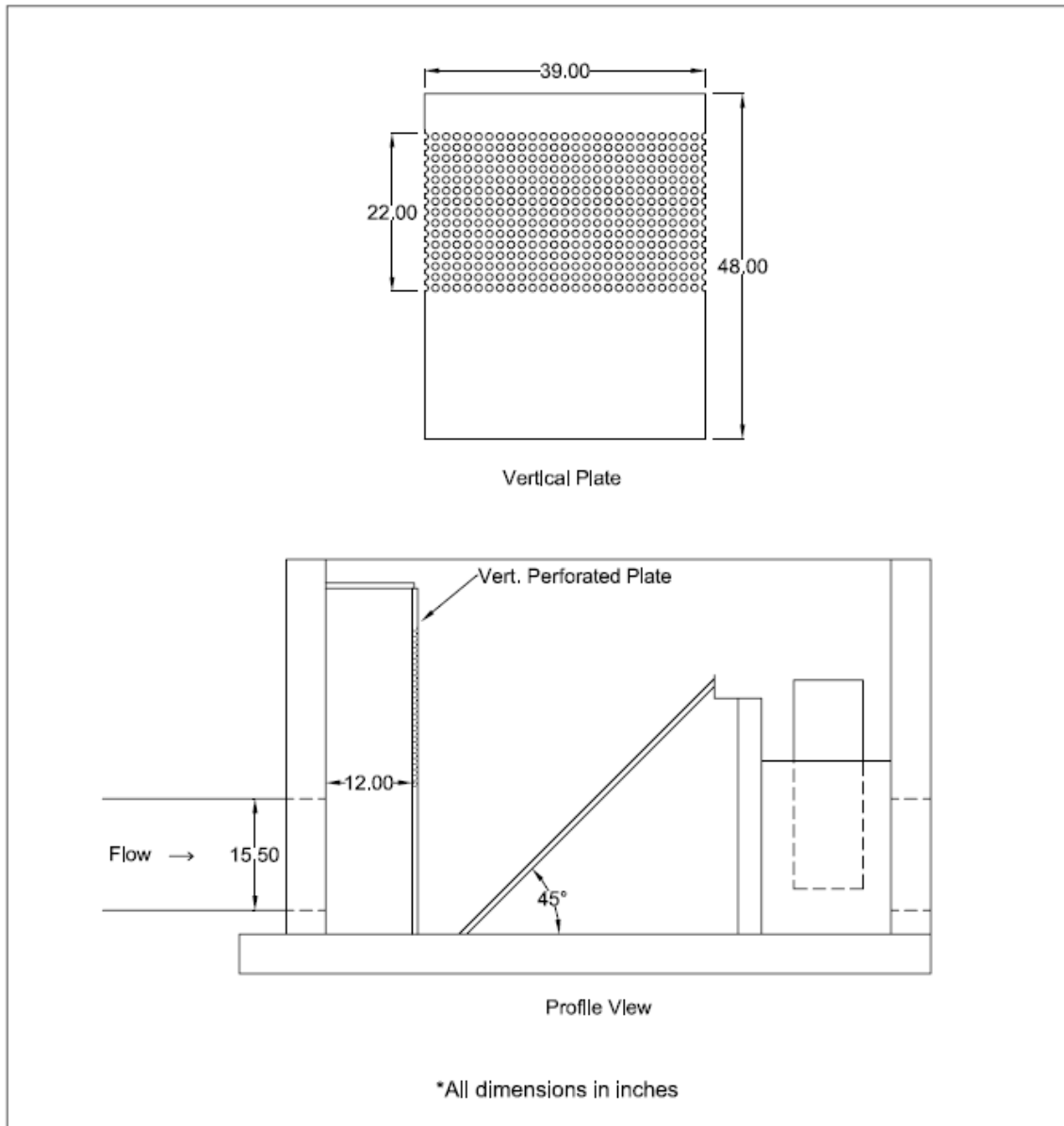

Figure 46. Drawing of Config. 4-6b.

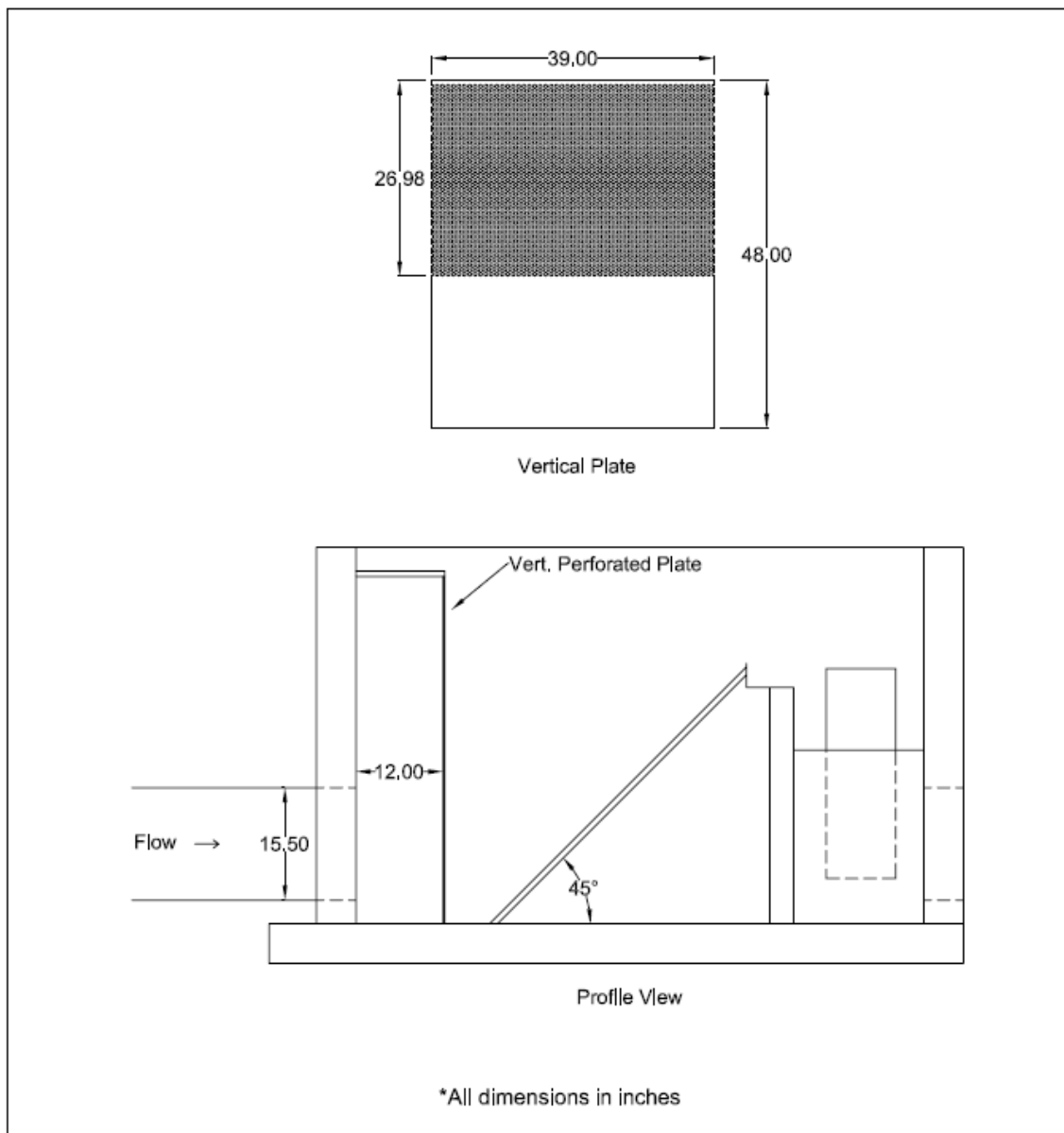

Figure 47. Drawing of Config. 4-8.

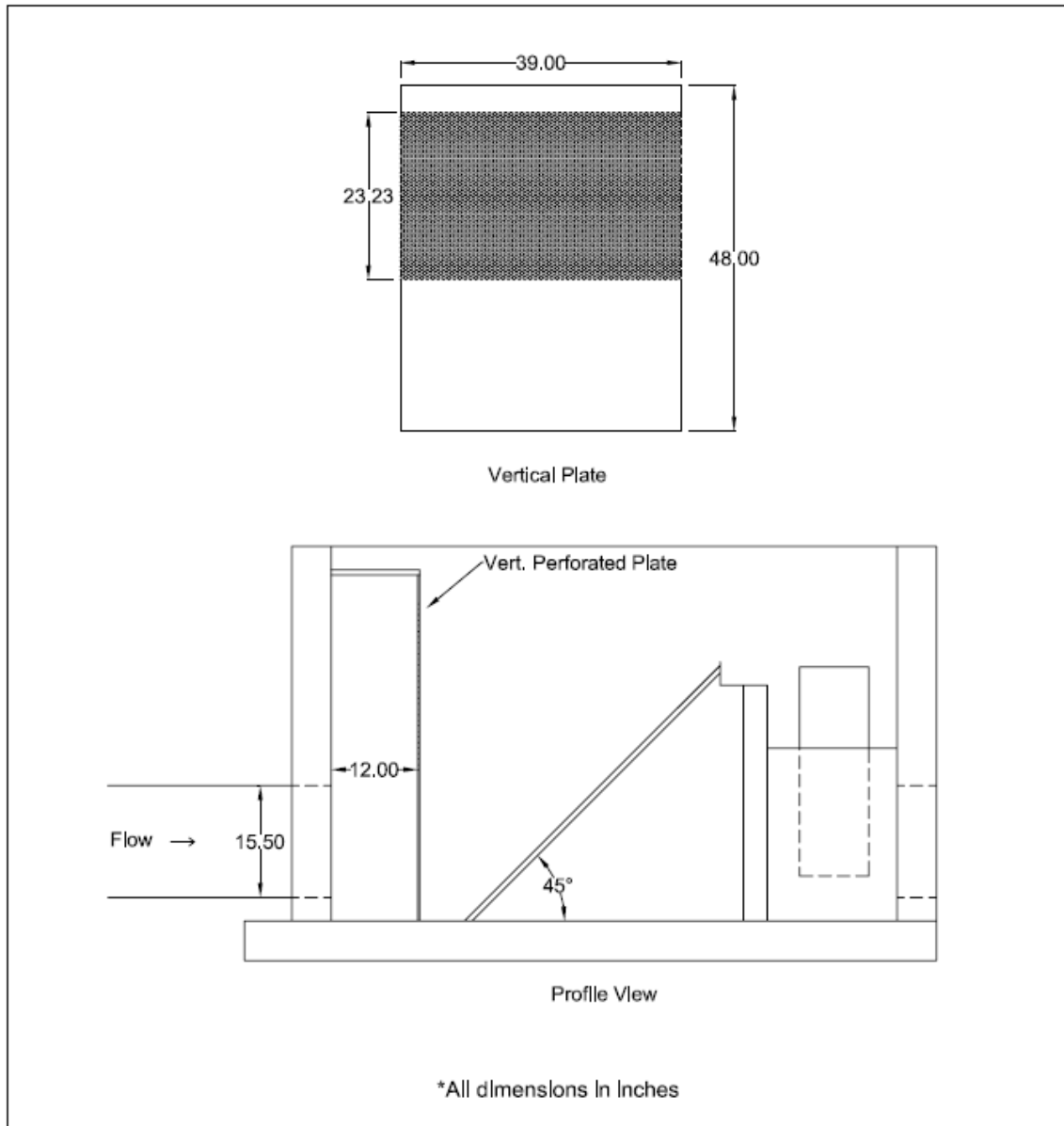

Figure 48. Drawing of Config. 4-8b.

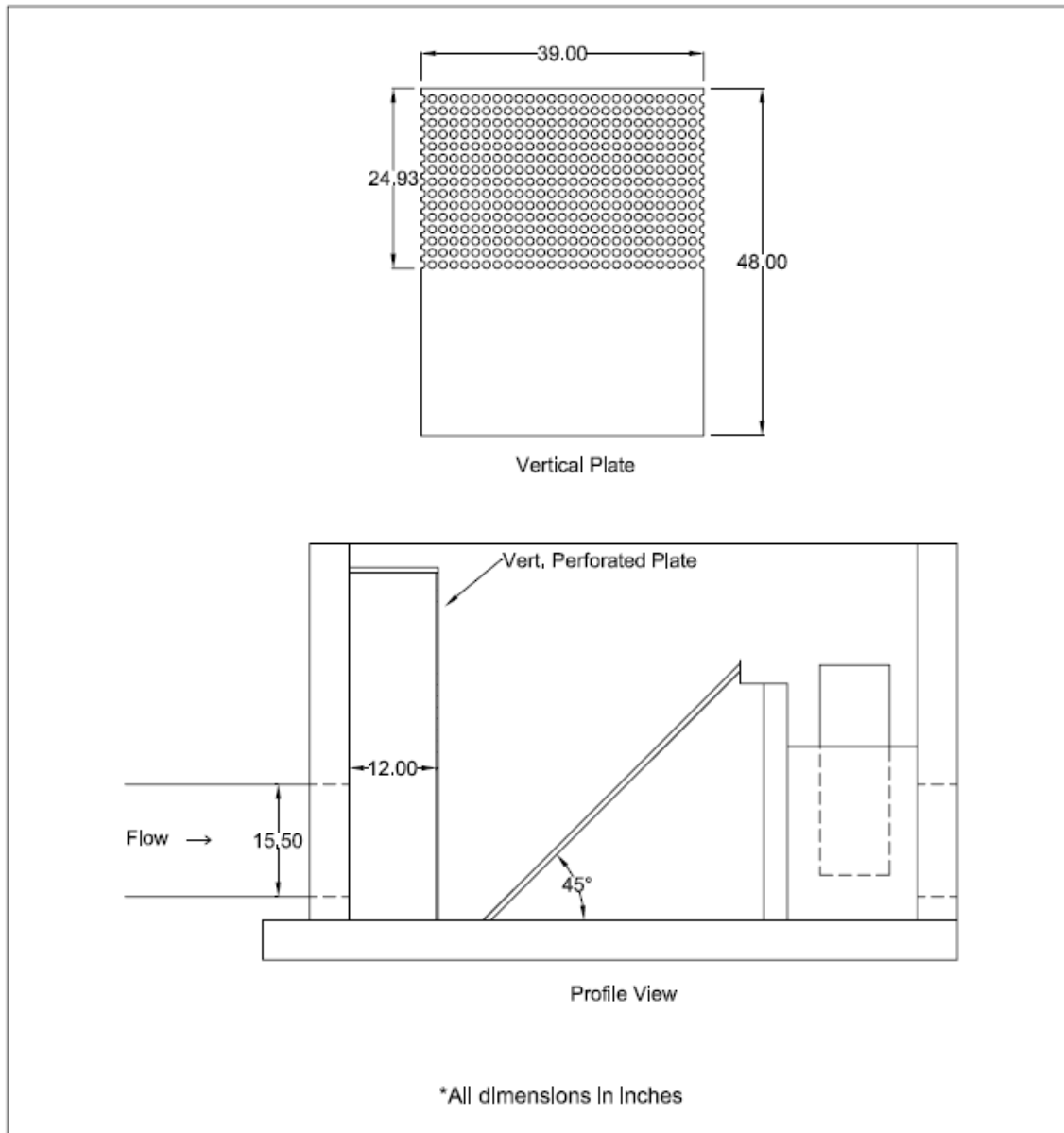

Figure 49. Drawing of Config. 4-10.

Appendix C: Drawing of Complete Setup in Lab

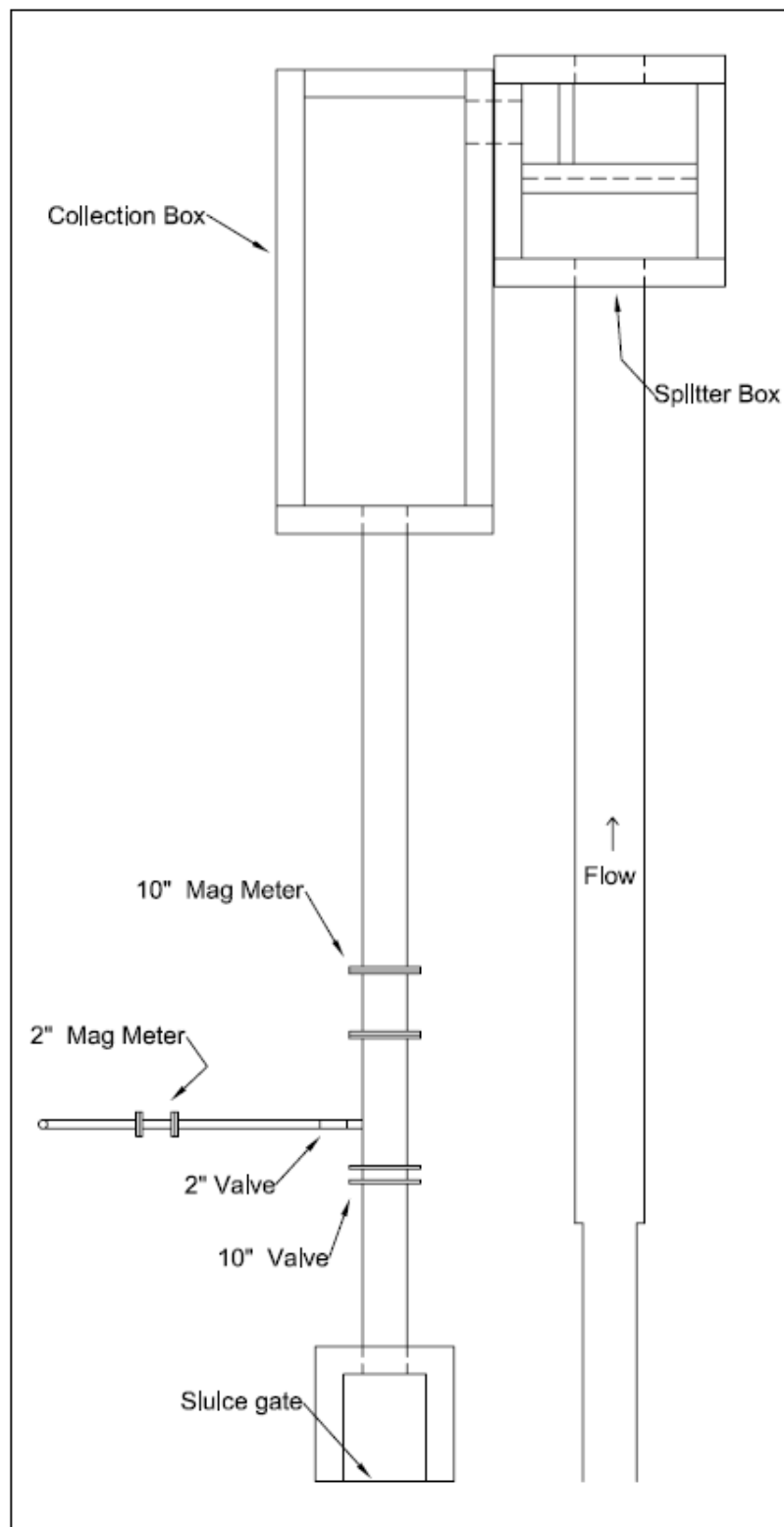

Figure 50. Complete Setup of Model in the Lab.

Appendix D: Flow Split Data

Table 9. Flow split data for Config. 1-Baseline.

Splitter Setting	Flow In	Predicted Flow Split	10" Mag. Meter Reading	Actual Flow Split	% split	2" Mag. Meter Reading	Actual Flow Split	% split
(%)	(gpm)	(gpm)	(V)	(gpm)	(%)	(Hz)	(gpm)	(%)
1	496.5	4.96	1.0117	5.9	1.2	249.2	6.2	1.3
	984.2	9.84	1.0272	13.6	1.4	551.4	13.8	1.4
	1487.7	14.88	1.0596	29.8	2.0			
	1967.2	19.67	1.0673	33.7	1.7			
	2686.4	26.86	1.0927	46.4	1.7			
	3404.0	34.04	1.1004	50.2	1.5			
2.5	496.2	12.41	1.0267	13.4	2.7	551.4	13.8	2.8
	986.0	24.65	1.0645	32.3	3.3	1308.9	32.7	3.3
	1483.6	37.09	1.118	59.0	4.0			
	1984.8	49.62	1.178	89.0	4.5			
	2669.6	66.74	1.237	118.5	4.4			
	3412.0	85.30	1.2498	124.9	3.7			
5	495.5	24.78	1.0495	24.8	5.0			
	976.0	48.80	1.1181	59.1	6.1			
	1475.5	73.78	1.2101	105.1	7.1			
	1962.4	98.12	1.3036	151.8	7.7			
	2659.2	132.96	1.3964	198.2	7.5			
	3400.8	170.04	1.4161	208.1	6.1			
10	488.3	48.83	1.1032	51.6	10.6			
	967.8	96.78	1.221	110.5	11.4			
	1479.4	147.94	1.3591	179.6	12.1			
	1975.2	197.52	1.4852	242.6	12.3			
	2663.2	266.32	1.5881	294.1	11.0			
	3383.2	338.32	1.6577	328.9	9.7			
20	497.4	99.49	1.2015	100.8	20.3			
	988.0	197.60	1.4202	210.1	21.3			
	1482.2	296.45	1.6106	305.3	20.6			
	1965.6	393.12	1.6896	344.8	17.5			
	2661.6	532.32	1.8725	436.3	16.4			
	3398.4	679.68	2.027	513.5	15.1			
35	496.2	173.68	1.3441	172.1	34.7			
	987.5	345.63	1.6643	332.2	33.6			
	1492.1	522.23	1.9412	470.6	31.5			
	1990.4	696.64	2.127	563.5	28.3			
	2664.8	932.68	2.445	722.5	27.1			
	3416.0	1195.60	2.817	908.5	26.6			

Table 10. Flow split data for Config. 1-6.

Splitter Setting	Flow In	Predicted Flow Split	10" Mag. Meter Reading	Actual Flow Split	% split	2" Mag. Meter Reading	Actual Flow Split	% split
(%)	(gpm)	(gpm)	(V)	(gpm)	(%)	(Hz)	(gpm)	(%)
1	494.6	4.95	1.0095	4.8	0.96	207.2	5.2	1.05
	986.3	9.86	1.0212	10.6	1.07	433.4	10.8	1.10
	1476.7	14.77	1.0328	16.4	1.11	662.5	16.6	1.12
	1978.4	19.78	1.0473	23.6	1.20	972.6	24.3	1.23
	2674.4	26.74	1.0667	33.4	1.25			
	3405.6	34.06	1.0809	40.5	1.19			
2.5	492.4	12.31	1.0251	12.6	2.55	511.5	12.8	2.60
	992.7	24.82	1.0524	26.2	2.64	1061.9	26.5	2.67
	1499.2	37.48	1.0888	44.4	2.96			
	1977.6	49.44	1.1169	58.5	2.96			
	2673.6	66.84	1.155	77.5	2.90			
	3407.2	85.18	1.202	101.0	2.96			
5	490.9	24.54	1.048	24.0	4.89			
	980.6	49.03	1.0992	49.6	5.06			
	1481.3	74.06	1.1528	76.4	5.16			
	1978.4	98.92	1.2067	103.4	5.22			
	2668.8	133.44	1.2694	134.7	5.05			
	3415.2	170.76	1.3731	186.6	5.46			
10	496.6	49.66	1.0996	49.8	10.03			
	986.6	98.66	1.2019	101.0	10.23			
	1473.0	147.30	1.295	147.5	10.01			
	1968.8	196.88	1.3746	187.3	9.51			
	2682.4	268.24	1.4854	242.7	9.05			
	3383.2	338.32	1.6372	318.6	9.42			
20	492.6	98.51	1.199	99.5	20.20			
	984.6	196.91	1.3951	197.6	20.06			
	1481.3	296.26	1.5966	298.3	20.14			
	1973.6	394.72	1.7966	398.3	20.18			
	2679.2	535.84	2.07	535.0	19.97			
	3423.2	684.64	2.388	694.0	20.27			
35	493.4	172.70	1.3449	172.5	34.95			
	992.6	347.40	1.6972	348.6	35.12			
	1479.8	517.92	2.039	519.5	35.11			
	1994.4	698.04	2.384	692.0	34.70			
	2656.0	929.60	2.848	924.0	34.79			
	3412.0	1194.20	3.398	1199.0	35.14			

Table 11. Flow split data for Config. 1-7.

Splitter Setting	Flow In	Predicted Flow Split	10" Mag. Meter Reading	Actual Flow Split	% split	2" Mag. Meter Reading	Actual Flow Split	% split
(%)	(gpm)	(gpm)	(V)	(gpm)	(%)	(Hz)	(gpm)	(%)
1	485.7	4.86	1.0094	4.7	0.97	205.9	5.1	1.06
	990.2	9.90	1.0211	10.5	1.07	432.8	10.8	1.09
	1480.4	14.80	1.031	15.5	1.05	630	15.8	1.06
	1992.8	19.93	1.0389	19.5	0.98	782.6	19.6	0.98
	2678.4	26.78	1.0598	29.9	1.12			
	3428.8	34.29	1.0803	40.2	1.17			
2.5	493.2	12.33	1.0247	12.4	2.50	500.8	12.5	2.54
	992.9	24.82	1.0529	26.5	2.66	1067.8	26.7	2.69
	1492.2	37.30	1.0823	41.2	2.76			
	1975.2	49.38	1.0959	48.0	2.43			
	2662.4	66.56	1.1327	66.4	2.49			
	3406.4	85.16	1.1867	93.4	2.74			
5	495.0	24.75	1.048	24.0	4.85			
	980.9	49.04	1.0973	48.7	4.96			
	1472.1	73.60	1.1455	72.8	4.94			
	1973.6	98.68	1.174	87.0	4.41			
	2663.2	133.16	1.2237	111.9	4.20			
	3422.4	171.12	1.3149	157.5	4.60			
10	507.0	50.70	1.1015	50.8	10.01			
	982.6	98.26	1.2008	100.4	10.22			
	1489.5	148.95	1.2941	147.1	9.87			
	1980.8	198.08	1.3528	176.4	8.91			
	2663.2	266.32	1.4723	236.2	8.87			
	3411.2	341.12	1.6308	315.4	9.25			
20	495.8	99.15	1.1989	99.5	20.06			
	987.4	197.47	1.3924	196.2	19.87			
	1486.6	297.31	1.5877	293.9	19.77			
	1978.4	395.68	1.7712	385.6	19.49			
	2665.6	533.12	2.057	528.5	19.83			
	3401.6	680.32	2.331	665.5	19.56			
35	496.5	173.77	1.3498	174.9	35.23			
	987.0	345.44	1.6905	345.3	34.98			
	1481.3	518.45	2.038	519.0	35.04			
	1965.6	687.96	2.363	681.5	34.67			
	2670.4	934.64	2.853	926.5	34.70			
	3396.8	1188.88	3.35	1175.0	34.59			

Table 12. Flow split data for Config. 1-8.

Splitter Setting	Flow In	Predicted Flow Split	10" Mag. Meter Reading	Actual Flow Split	% split	2" Mag. Meter Reading	Actual Flow Split	% split
(%)	(gpm)	(gpm)	(V)	(gpm)	(%)	(Hz)	(gpm)	(%)
1	495.4	4.95	1.0097	4.9	1.0	211.1	5.28	1.1
	987.8	9.88	1.0219	11.0	1.1	448.6	11.22	1.1
	1483.7	14.84	1.0343	17.2	1.2	682	17.05	1.1
	1980.8	19.81	1.0449	22.5	1.1	911.5	22.79	1.2
	2666.4	26.66	1.066	33.0	1.2			
	3404.8	34.05	1.081	40.5	1.2			
2.5	496.1	12.40	1.0267	13.4	2.7	548.5	13.71	2.8
	995.0	24.88	1.0507	25.4	2.5	1035.5	25.89	2.6
	1474.6	36.87	1.0757	37.9	2.6	1557.7	38.94	2.6
	1975.2	49.38	1.1028	51.4	2.6			
	2660.0	66.50	1.1405	70.3	2.6			
	3408.0	85.20	1.1861	93.1	2.7			
5	495.0	24.75	1.0471	23.6	4.8			
	984.8	49.24	1.0995	49.8	5.1			
	1487.8	74.39	1.154	77.0	5.2			
	1972.0	98.60	1.194	97.0	4.9			
	2652.8	132.64	1.263	131.5	5.0			
	3404.8	170.24	1.3488	174.4	5.1			
10	480.2	48.02	1.0979	49.0	10.2			
	998.6	99.86	1.2052	102.6	10.3			
	1490.8	149.08	1.2952	147.6	9.9			
	1985.6	198.56	1.3792	189.6	9.5			
	2681.6	268.16	1.4974	248.7	9.3			
	3414.4	341.44	1.637	318.5	9.3			
20	498.1	99.62	1.1972	98.6	19.8			
	980.0	196.00	1.3894	194.7	19.9			
	1485.5	297.10	1.5891	294.6	19.8			
	1980.0	396.00	1.7665	383.3	19.4			
	2672.8	534.56	2.035	517.5	19.4			
	3412.0	682.40	2.282	641.0	18.8			
35	496.6	173.80	1.3456	172.8	34.8			
	985.2	344.82	1.6869	343.5	34.9			
	1476.3	516.71	2.029	514.5	34.9			
	1976.8	691.88	2.395	697.5	35.3			
	2660.0	931.00	2.869	934.5	35.1			
	3402.4	1190.84	3.353	1176.5	34.6			

Table 13. Flow split data for Config. 1-8a.

Splitter Setting	Flow In	Predicted Flow Split	10" Mag. Meter Reading	Actual Flow Split	% split
(%)	(gpm)	(gpm)	(V)	(gpm)	(%)
1	1974.4	19.74	1.0462	23.1	1.17
	2466.4	24.66	1.0626	31.3	1.27
	2964.8	29.65	1.0784	39.2	1.32
	3408.8	34.09	1.0889	44.5	1.30
2.5	1980.0	49.50	1.1133	56.7	2.86
	2470.4	61.76	1.155	77.5	3.14
	2974.4	74.36	1.1893	94.7	3.18
	3428.0	85.70	1.2127	106.4	3.10
5	1978.4	98.92	1.2131	106.6	5.39
	2469.6	123.48	1.2772	138.6	5.61
	2964.0	148.20	1.3308	165.4	5.58
	3420.8	171.04	1.3746	187.3	5.48
10	1988.0	198.80	1.3785	189.3	9.52
	2476.8	247.68	1.468	234.0	9.45
	2975.2	297.52	1.5696	284.8	9.57
	3434.4	343.44	1.662	331.0	9.64

Table 14. Flow split data for Config. 1-9.

Splitter Setting	Flow In	Predicted Flow Split	10" Mag. Meter Reading	Actual Flow Split	% split
(%)	(gpm)	(gpm)	(V)	(gpm)	(%)
1	1976.0	19.76	1.0431	21.6	1.09
	2464.0	24.64	1.0505	25.3	1.02
	2972.8	29.73	1.0684	34.2	1.15
	3412.8	34.13	1.0966	48.3	1.42
2.5	1967.2	49.18	1.1125	56.3	2.86
	2464.8	61.62	1.1241	62.1	2.52
	2968.0	74.20	1.1619	81.0	2.73
	3411.2	85.28	1.2064	103.2	3.03
5	1976.0	98.80	1.224	112.0	5.67
	2475.2	123.76	1.2519	126.0	5.09
	2957.6	147.88	1.3115	155.8	5.27
	3407.2	170.36	1.3942	197.1	5.78
10	1973.6	197.36	1.3891	194.6	9.86
	2467.2	246.72	1.472	236.0	9.57
	2972.8	297.28	1.5812	290.6	9.78
	3403.2	340.32	1.7073	353.7	10.39
20	1976.0	197.60	1.7992	399.6	20.22
	2472.0	247.20	1.977	488.5	19.76
	2975.2	297.52	2.18	590.0	19.83
	3412.0	341.20	2.372	686.0	20.11

Table 15. Flow split data for Config. 2-Baseline.

Splitter Setting	Flow In	Predicted Flow Split	10" Mag. Meter Reading	Actual Flow Split	% split
(%)	(gpm)	(gpm)	(V)	(gpm)	(%)
5	1491.7	298.34	1.1809	90.5	6.1
	1980.0	396.00	1.2409	120.5	6.1
	2473.6	494.72	1.3118	155.9	6.3
	2972.0	594.40	1.3894	194.7	6.6
	3400.0	680.00	1.474	237.0	7.0
20	1484.0	296.80	1.5618	280.9	18.9
	1984.0	396.80	1.7243	362.2	18.3
	2488.0	497.60	1.8927	446.4	17.9
	2981.6	596.32	2.074	537.0	18.0
	3397.6	679.52	2.24	620.0	18.2

Table 16. Flow split data for Config. 2-6.

Splitter Setting	Flow In	Predicted Flow Split	10" Mag. Meter Reading	Actual Flow Split	% split
(%)	(gpm)	(gpm)	(V)	(gpm)	(%)
5	1489.4	297.89	1.1499	75.0	5.03
	1980.8	396.16	1.2026	101.3	5.11
	2463.2	492.64	1.2647	132.4	5.37
	2959.2	591.84	1.3125	156.3	5.28
	3401.6	680.32	1.3623	181.2	5.33
20	1481.6	296.32	1.5905	295.3	19.93
	1982.4	396.48	1.7864	393.2	19.83
	2472.8	494.56	1.995	497.5	20.12
	2976.8	595.36	2.185	592.5	19.90
	3419.2	683.84	2.359	679.5	19.87

Table 17. Flow split data for Config. 2-8.

Splitter Setting	Flow In	Predicted Flow Split	10" Mag. Meter Reading	Actual Flow Split	% split
(%)	(gpm)	(gpm)	(V)	(gpm)	(%)
5	1491.7	298.34	1.1451	72.6	4.86
	1975.2	395.04	1.1951	97.6	4.94
	2456.0	491.20	1.2567	128.4	5.23
	2961.6	592.32	1.3018	150.9	5.10
	3399.2	679.84	1.3494	174.7	5.14
20	1480.2	296.05	1.5792	289.6	19.56
	1975.2	395.04	1.7688	384.4	19.46
	2477.6	495.52	1.983	491.5	19.84
	2945.6	589.12	2.15	575.0	19.52
	3408.8	681.76	2.32	660.0	19.36

Table 18. Flow split data for Config. 3-Baseline.

Splitter Setting	Flow In	Predicted Flow Split	10" Mag. Meter Reading	Actual Flow Split	% split	2" Mag. Meter Reading	Actual Flow Split	% split
(%)	(gpm)	(gpm)	(V)	(gpm)	(%)	(Hz)	(gpm)	(%)
1	497.9	4.98	1.0125	6.2	1.3	269.3	6.7	1.4
	989.9	9.90	1.0301	15.1	1.5	617	15.4	1.6
	1476.6	14.77	1.0546	27.3	1.8			
	1984.8	19.85	1.0723	36.2	1.8			
	2668.8	26.69	1.12	60.0	2.2			
	3412.8	34.13	1.1661	83.1	2.4			
2.5	500.5	12.51	1.0266	13.3	2.7	544.1	13.6	2.7
	987.5	24.69	1.0636	31.8	3.2	1290.5	32.3	3.3
	1475.6	36.89	1.1094	54.7	3.7			
	1971.2	49.28	1.161	80.5	4.1			
	2668.8	66.72	1.2692	134.6	5.0			
	3414.4	85.36	1.373	186.5	5.5			
5	497.4	24.87	1.0526	26.3	5.3			
	981.0	49.05	1.121	60.5	6.2			
	1472.2	73.61	1.2077	103.9	7.1			
	2003.2	100.16	1.3192	159.6	8.0			
	2665.6	133.28	1.4608	230.4	8.6			
	3409.6	170.48	1.668	334.0	9.8			
10	495.9	49.59	1.1053	52.7	10.6			
	978.6	97.86	1.2212	110.6	11.3			
	1485.2	148.52	1.3589	179.5	12.1			
	1968.0	196.80	1.5098	254.9	13.0			
	2666.4	266.64	1.7109	355.5	13.3			
	3396.0	339.60	1.981	490.5	14.4			
20	492.5	98.50	1.2062	103.1	20.9			
	997.8	199.57	1.4255	212.8	21.3			
	1494.5	298.90	1.6503	325.2	21.8			
	1970.4	394.08	1.8802	440.1	22.3			
	2668.0	533.60	2.156	578.0	21.7			
	3392.8	678.56	2.497	748.5	22.1			
35	502.2	175.78	1.3563	178.2	35.5			
	987.8	345.74	1.708	354.0	35.8			
	1482.2	518.76	2.081	540.5	36.5			
	1982.4	693.84	2.451	725.5	36.6			
	2663.2	932.12	2.869	934.5	35.1			
	3413.6	1194.76	3.393	1196.5	35.1			

Table 19. Flow split data for Config. 3-6.

Splitter Setting	Flow In	Predicted Flow Split	10" Mag. Meter Reading	Actual Flow Split	% split	2" Mag. Meter Reading	Actual Flow Split	% split
(%)	(gpm)	(gpm)	(V)	(gpm)	(%)	(Hz)	(gpm)	(%)
1	496.6	4.97	1.0108	5.4	1.09	237.8	5.9	1.20
	992.8	9.93	1.0244	12.2	1.23	505.2	12.6	1.27
	1480.9	14.81	1.0336	16.8	1.13	684.5	17.1	1.16
	1984.0	19.84	1.041	20.5	1.03	836.4	20.9	1.05
	2665.6	26.66	1.056	28.0	1.05			
	3392.8	33.93	1.0671	33.6	0.99			
2.5	490.8	12.27	1.0241	12.1	2.46	498.7	12.5	2.54
	989.8	24.74	1.053	26.5	2.68	1076.6	26.9	2.72
	1476.3	36.91	1.0798	39.9	2.70			
	1988.8	49.72	1.0984	49.2	2.47			
	2661.6	66.54	1.1204	60.2	2.26			
	3413.6	85.34	1.1443	72.2	2.11			
5	497.2	24.86	1.0491	24.6	4.94			
	992.1	49.60	1.0988	49.4	4.98			
	1490.6	74.53	1.1466	73.3	4.92			
	1964.8	98.24	1.1844	92.2	4.69			
	2668.0	133.40	1.233	116.5	4.37			
	3400.0	170.00	1.2847	142.4	4.19			
10	493.1	49.31	1.1007	50.4	10.21			
	996.5	99.65	1.1966	98.3	9.86			
	1492.5	149.25	1.2838	141.9	9.51			
	1966.4	196.64	1.3614	180.7	9.19			
	2668.0	266.80	1.472	236.0	8.85			
	3413.6	341.36	1.5946	297.3	8.71			
20	497.0	99.41	1.2045	102.3	20.57			
	1004.6	200.93	1.3953	197.7	19.67			
	1491.6	298.32	1.5563	278.2	18.65			
	1980.0	396.00	1.7076	353.8	17.87			
	2684.0	536.80	1.8823	441.2	16.44			
	3398.4	679.68	2.112	556.0	16.36			
35	502.6	175.90	1.3569	178.5	35.51			
	1002.6	350.90	1.706	353.0	35.21			
	1474.2	515.98	2.038	519.0	35.20			
	1986.4	695.24	2.384	692.0	34.84			
	2667.2	933.52	2.87	935.0	35.06			
	3424.0	1198.40	3.351	1175.5	34.33			

Table 20. Flow split data for Config. 3-7.

Splitter Setting	Flow In	Predicted Flow Split	10" Mag. Meter Reading	Actual Flow Split	% split	2" Mag. Meter Reading	Actual Flow Split	% split
(%)	(gpm)	(gpm)	(V)	(gpm)	(%)	(Hz)	(gpm)	(%)
1	499.2	4.99	1.0107	5.3	1.07	234.8	5.9	1.18
	980.6	9.81	1.0222	11.1	1.13	460.6	11.5	1.17
	1479.8	14.80	1.0304	15.2	1.03	628.9	15.7	1.06
	1972.0	19.72	1.038	19.0	0.96	774	19.4	0.98
	2667.2	26.67	1.0569	28.5	1.07			
	3396.8	33.97	1.0708	35.4	1.04			
2.5	490.9	12.27	1.0238	11.9	2.42	492.3	12.3	2.51
	1001.1	25.03	1.053	26.5	2.65	1077	26.9	2.69
	1490.2	37.25	1.0758	37.9	2.54			
	1971.2	49.28	1.0925	46.3	2.35			
	2684.0	67.10	1.1178	58.9	2.19			
	3400.0	85.00	1.1398	69.9	2.06			
5	489.7	24.48	1.0478	23.9	4.88			
	991.8	49.59	1.0993	49.7	5.01			
	1497.7	74.88	1.1477	73.9	4.93			
	1975.2	98.76	1.1875	93.8	4.75			
	2676.0	133.80	1.2383	119.2	4.45			
	3412.0	170.60	1.2911	145.6	4.27			
10	493.1	49.31	1.1008	50.4	10.22			
	1001.1	100.11	1.1966	98.3	9.82			
	1490.5	149.05	1.2815	140.8	9.44			
	1969.6	196.96	1.35852	179.3	9.10			
	2667.2	266.72	1.472	236.0	8.85			
	3399.2	339.92	1.5864	293.2	8.63			
20	497.1	99.42	1.2049	102.5	20.61			
	1003.1	200.62	1.4083	204.2	20.35			
	1499.0	299.81	1.6002	300.1	20.02			
	1988.8	397.76	1.7828	391.4	19.68			
	2680.0	536.00	2.021	510.5	19.05			
	3406.4	681.28	2.246	623.0	18.29			
35	500.5	175.17	1.3553	177.7	35.50			
	981.3	343.45	1.6862	343.1	34.96			
	1484.3	519.51	2.015	507.5	34.19			
	1981.6	693.56	2.346	673.0	33.96			
	2657.6	930.16	2.767	883.5	33.24			
	3404.8	1191.68	3.241	1120.5	32.91			

Table 21. Flow split data for Config. 3-8.

Splitter Setting	Flow In	Predicted Flow Split	10" Mag. Meter Reading	Actual Flow Split	% split	2" Mag. Meter Reading	Actual Flow Split	% split
(%)	(gpm)	(gpm)	(V)	(gpm)	(%)	(Hz)	(gpm)	(%)
1	494.5	4.94	1.0112	5.6	1.13	242.5	6.1	1.23
	987.3	9.87	1.0236	11.8	1.20	484.9	12.1	1.23
	1482.8	14.83	1.0372	18.6	1.25	756.3	18.9	1.28
	1975.2	19.75	1.0474	23.7	1.20	960	24.0	1.22
	2676.0	26.76	1.0651	32.6	1.22			
	3414.4	34.14	1.0691	34.6	1.01			
2.5	500.2	12.50	1.0242	12.1	2.42	500.6	12.5	2.50
	987.0	24.68	1.0506	25.3	2.56	1034.3	25.9	2.62
	1488.6	37.21	1.0753	37.7	2.53			
	1988.8	49.72	1.0968	48.4	2.43			
	2676.0	66.90	1.1335	66.8	2.49			
	3415.2	85.38	1.1622	81.1	2.37			
5	490.2	24.51	1.0509	25.5	5.19			
	987.2	49.36	1.1014	50.7	5.14			
	1479.1	73.96	1.149	74.5	5.04			
	1972.8	98.64	1.1924	96.2	4.88			
	2666.4	133.32	1.2664	133.2	5.00			
	3394.4	169.72	1.3242	162.1	4.78			
10	499.6	49.96	1.1015	50.8	10.16			
	993.7	99.37	1.2021	101.1	10.17			
	1512.2	151.22	1.3005	150.3	9.94			
	1980.0	198.00	1.3822	191.1	9.65			
	2679.2	267.92	1.508	254.0	9.48			
	3384.0	338.40	1.596	298.0	8.81			
20	498.2	99.63	1.2073	103.7	20.81			
	991.8	198.37	1.4055	202.8	20.44			
	1482.0	296.40	1.5932	296.6	20.01			
	1978.4	395.68	1.7746	387.3	19.58			
	2684.0	536.80	2.022	511.0	19.04			
	3420.8	684.16	2.206	603.0	17.63			
35	501.0	175.34	1.3558	177.9	35.51			
	989.8	346.44	1.6992	349.6	35.32			
	1481.4	518.50	2.039	519.5	35.07			
	1984.0	694.40	2.388	694.0	34.98			
	2675.2	936.32	2.872	936.0	34.99			
	3392.8	1187.48	3.318	1159.0	34.16			

Table 22. Flow split data for Config. 4-6b.

Splitter Setting	Flow In	Predicted Flow Split	10" Mag. Meter Reading	Actual Flow Split	% split	2" Mag. Meter Reading	Actual Flow Split	% split
(%)	(gpm)	(gpm)	(V)	(gpm)	(%)	(Hz)	(gpm)	(%)
1	996.5	9.96	1.0215	10.8	1.08	440.7	11.0	1.11
	1494.3	14.94	1.0306	15.3	1.02	624.6	15.6	1.04
	1975.2	19.75	1.0398	19.9	1.01	812.2	20.3	1.03
	2677.6	26.78	1.0604	30.2	1.13			
	3420.0	34.20	1.0751	37.6	1.10			
10	499.0	49.90	1.1018	50.9	10.20			
	999.0	99.90	1.2064	103.2	10.33			
	1481.8	148.18	1.3037	151.9	10.25			
	1982.4	198.24	1.4009	200.5	10.11			
	2676.8	267.68	1.5431	271.6	10.14			
	3404.0	340.40	1.6889	344.5	10.12			

Table 23. Flow split data for Config. 4-8b.

Splitter Setting	Flow In	Predicted Flow Split	10" Mag. Meter Reading	Actual Flow Split	% split	2" Mag. Meter Reading	Actual Flow Split	% split
(%)	(gpm)	(gpm)	(V)	(gpm)	(%)	(Hz)	(gpm)	(%)
1	996.8	9.97	1.0206	10.3	1.03	424.8	10.6	1.07
	1477.8	14.78	1.0307	15.35	1.04	627.6	15.7	1.06
	1976.8	19.77	1.0405	20.25	1.02	822.5	20.6	1.04
	2665.6	26.66	1.0555	27.8	1.04			
	3419.2	34.19	1.0762	38.1	1.11			
10	489.4	48.94	1.1013	50.7	10.35			
	979.8	97.98	1.2057	102.9	10.50			
	1495.4	149.54	1.3116	155.8	10.42			
	1977.6	197.76	1.4066	203.3	10.28			
	2659.2	265.92	1.5466	273.3	10.28			
	3404.0	340.40	1.7066	353.3	10.38			

Table 24. Flow split data for Config. 4-10.

Splitter Setting	Flow In	Predicted Flow Split	10" Mag. Meter Reading	Actual Flow Split	% split
(%)	(gpm)	(gpm)	(V)	(gpm)	(%)
10	491.0	49.10	1.1008	50.4	10.3%
	981.7	98.17	1.2029	101.5	10.3%
	1471.7	147.17	1.304	152.0	10.3%
	1992.0	199.20	1.4016	200.8	10.1%
	2648.8	264.88	1.5386	269.3	10.2%
	3404.0	340.40	1.716	358.0	10.5%

Appendix E: Upstream Pressure Head Data

Table 25. Upstream Pressure Head Data for Configuration 1.

Splitter Setting (%)	Approx. Flow (gpm)	Config. 1-Baseline (in)	Config. 1-6 (in)	Config. 1-7 (in)	Config. 1-8 (in)	Config. 1-8a (in)	Config. 1-9 (in)
1	500	27.750	28.000	28.000	28.000	-	-
	980	29.250	30.250	30.000	30.000	-	-
	1480	30.500	32.375	32.125	32.000	-	-
	1970	31.500	34.625	33.750	33.875	33.750	33.000
	2470	-	-	-	-	35.625	34.625
	2680	32.750	38.125	36.875	37.125	-	-
	2970	-	-	-	-	38.000	36.250
	3400	34.125	42.000	40.625	40.375	40.250	37.625
2.5	500	27.875	28.125	28.000	28.000	-	-
	980	29.375	30.375	30.000	30.125	-	-
	1480	30.500	32.375	32.000	32.125	-	-
	1970	31.500	34.625	34.000	34.250	33.750	33.000
	2470	-	-	-	-	35.875	34.625
	2680	33.250	38.125	37.000	37.500	-	-
	2970	-	-	-	-	38.125	36.500
	3400	34.500	41.875	40.750	40.625	40.250	38.000
5	500	27.875	28.000	28.000	28.000	-	-
	980	29.250	30.125	30.000	30.250	-	-
	1480	30.500	32.375	31.875	32.125	-	-
	1970	31.625	34.375	33.875	34.250	33.750	33.000
	2470	-	-	-	-	35.750	34.750
	2680	33.125	37.500	37.000	37.375	-	-
	2970	-	-	-	-	38.000	36.375
	3400	34.375	41.750	40.750	40.625	40.125	38.000
10	500	27.750	28.000	28.000	28.000	-	-
	980	29.250	30.250	30.000	-	-	-
	1480	30.375	32.250	31.875	32.125	-	-
	1970	31.375	34.375	33.875	34.125	33.750	33.000
	2470	-	-	-	-	35.875	34.625
	2680	33.125	38.375	36.875	37.625	-	-
	2970	-	-	-	-	38.000	36.500
	3400	34.625	41.875	40.750	41.000	40.250	38.125

Table 25 cont'd. Upstream Pressure Head Data for Configuration 1.

20	500	28.000	28.000	28.000	28.000	-	-
	980	29.375	30.250	30.125	30.125	-	-
	1480	30.500	32.250	32.125	32.250	-	-
	1970	31.500	34.500	34.000	34.375	-	33.000
	2470	-	-	-	-	-	34.500
	2680	33.125	38.125	36.875	37.625	-	-
	2970	-	-	-	-	-	36.500
	3400	34.250	42.125	40.500	41.000	-	38.125
35	500	27.875	28.125	28.000	28.000	-	-
	980	29.375	30.250	30.000	30.000	-	-
	1480	30.625	32.375	32.000	32.125	-	-
	1970	31.500	34.750	34.000	33.750	-	-
	2680	33.000	38.250	36.750	36.875	-	-
	3400	34.500	42.250	40.500	41.125	-	-

Table 26. Upstream Pressure Head Data for Configuration 2.

Splitter Setting (%)	Approx. Flow (gpm)	Config. 2-Baseline (in)	Config. 2-6 (in)	Config. 2-8 (in)
5	1480	30.875	31.875	32.000
	1970	32.125	33.875	33.875
	2470	33.125	35.750	35.875
	2970	34.125	37.625	37.625
	3400	35.250	40.000	39.625
20	1480	30.750	32.000	32.125
	1970	32.125	33.875	34.000
	2470	33.125	35.875	36.000
	2970	34.250	37.500	37.750
	3400	35.125	40.000	39.625

Table 27. Upstream Pressure Head Data for Configuration 3.

Splitter Setting	Approx. Flow	Config. 3-Baseline	Config. 3-6	Config. 3-7	Config. 3-8
(%)	(gpm)	(in)	(in)	(in)	(in)
1	500	27.875	28.000	28.000	28.000
	980	29.500	30.250	30.000	30.000
	1480	30.500	32.250	32.125	31.875
	1970	31.875	34.375	33.750	33.750
	2680	33.250	37.500	36.875	36.250
	3400	35.000	41.625	40.625	39.375
2.5	500	27.875	28.000	28.000	28.000
	980	29.375	30.375	30.000	29.875
	1480	30.500	32.375	32.000	32.125
	1970	31.625	34.375	34.000	33.625
	2680	33.250	37.375	37.000	36.125
	3400	35.000	41.875	40.750	39.250
5	500	27.750	28.000	28.000	28.000
	980	29.375	30.125	30.000	29.875
	1480	30.500	32.250	31.875	31.750
	1970	32.000	34.250	33.875	33.625
	2680	33.375	37.625	37.000	36.250
	3400	35.000	41.250	40.750	39.250
10	500	27.875	28.000	28.000	28.000
	980	29.375	30.125	30.000	30.000
	1480	30.750	32.250	31.875	32.000
	1970	31.750	34.250	33.875	33.750
	2680	33.625	37.625	36.875	36.250
	3400	35.000	41.500	40.750	39.125
20	500	27.875	28.000	28.000	28.000
	980	29.375	30.250	30.125	29.875
	1480	30.625	32.250	32.125	31.750
	1970	31.750	34.375	34.000	33.625
	2680	33.375	37.750	36.875	36.375
	3400	34.875	41.500	40.500	39.500
35	500	27.875	28.125	28.000	28.000
	980	29.375	30.250	30.000	30.000
	1480	30.625	32.250	32.000	31.875
	1970	31.750	34.375	34.000	33.750
	2680	33.375	37.625	36.750	36.250
	3400	35.250	41.625	40.500	39.500

Table 28. Upstream Pressure Head Data for Configuration 4.

Splitter Setting (%)	Approx. Flow (gpm)	Config. 4-6b (in)	Config. 4-8b (in)	Config. 4-10 (in)
1	500	-	-	-
	980	29.750	30.000	-
	1480	31.250	31.375	-
	1970	32.750	32.875	-
	2680	35.125	35.125	-
	3400	37.750	37.125	-
10	500	27.875	27.875	28.000
	980	29.625	29.625	29.750
	1480	31.250	31.375	31.375
	1970	32.750	32.750	33.250
	2680	35.000	35.000	35.875
	3400	37.750	39.125	39.250