



Test Results for the MPS-120 and MPS-130 CubeSat Propulsion Systems

**Christian Carpenter
Derek Schmuland
Jonathan Overly
Dr. Robert Masse**

The CubeSat Market Will Stagnate Unless New Mission Applications Can be Accessed



- The CubeSat platform enabled low cost space missions resulting in significant market growth
- CubeSat missions are limited to dispersion orbits and this limitation will eventually cause market stagnation
- A wider range of missions must be enabled to strengthen the value proposition of the CubeSat platform and ensure continued growth in the market
- Propulsive capabilities exclusively enable CubeSats to access all mission areas of interest
- CubeSat modular propulsion systems product line simplifies propulsion planning and integration so that any level of CubeSat builder can consider a propulsive mission

Nano/Microsatellite Launch History and Projections

Projections based on the announced plans of nano/microsatellite developers and programs indicate a range of 121 to 188 nano/microsatellites requiring launch by 2020

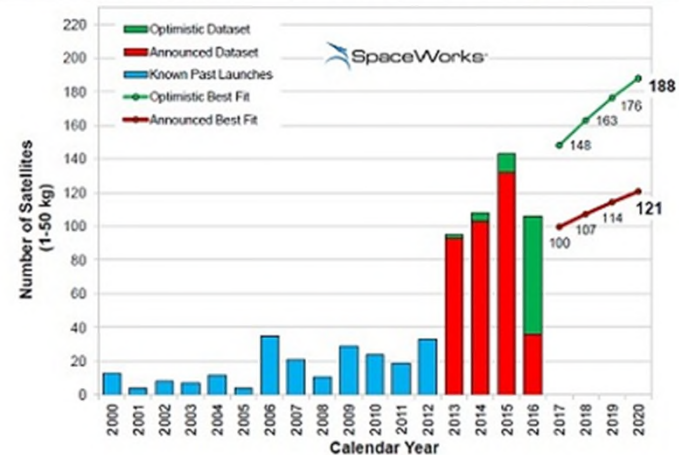





Source: SpaceWorks Nano/Microsatellite Market Assessment, Feb 2013
http://www.sei.aero/eng/papers/uploads/archive/SpaceWorks_NanoMicrosat_Market_Feb2013.pdf

**CubeSat Modular Propulsion Systems Product Line
Enables CubeSat Market Growth**

A Wide Range of CubeSat Propulsion Solutions are Required



Product Image	Product Number	Description	ΔV for 3U 4kg BOL	ΔV for 6U 10kg BOL
	MPS-110	<ul style="list-style-type: none"> System Mass: Varies depending on selected size Propellant: Inert gas Propulsion: 1 to 4 cold gas thrusters 	10 m/s	N/A
	MPS-120	<ul style="list-style-type: none"> System Mass: <1.3kg dry, <1.6kg wet Propellant: Hydrazine Propulsion: Four 0.26—2.8 N (BOL) rocket engines 	209 m/s	81 m/s
	MPS-130	<ul style="list-style-type: none"> System Mass: <1.3kg dry, <1.6kg wet Propellant: AF-M315E Propulsion: Four TBD—1 N (BOL) rocket engines 	340 m/s	130 m/s
	MPS-120XW	<ul style="list-style-type: none"> System Mass: <2.4kg dry, <3.2kg wet Propellant: Hydrazine Propulsion: Four 0.26—2.8 N (BOL) rocket engines 	440 m/s	166 m/s
	MPS-120XL	<ul style="list-style-type: none"> System Mass: <2.4kg dry, <3.2kg wet Propellant: Hydrazine Propulsion: Four 0.26—2.8 N (BOL) rocket engines 	539 m/s	200 m/s
Image Coming Soon	MPS-160	<ul style="list-style-type: none"> System Mass: TBD Propellant: Xenon Propulsion: 80W Solar Electric Power/Solar Electric Propulsion System (SEP²) 	N/A	>2,000 m/s

The MPS-100 Product Line Provides CubeSat Mission Planners with a Wide Range of Solutions

MPS-120 Demonstration Program



- MPS-120 is a 1U, hydrazine propulsion system
- NASA MPS-120 Demonstration program started in February 2014
- Program Objectives
 - Demonstrate 3D printed isolation system
 - Demonstrate 3D printed piston tank
 - Demonstrate MPS-120 system level hotfire (with one MR-142 engine)

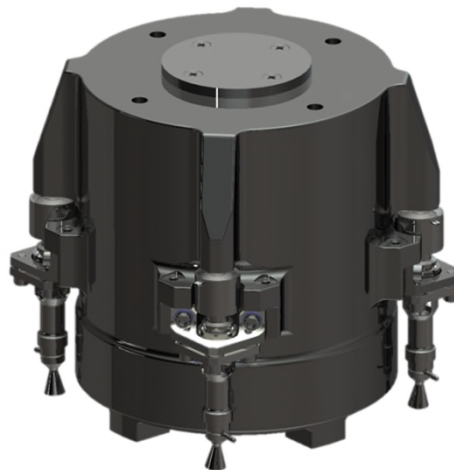

MPS-120

CubeSat
High-impulse
Adaptable
Modular
Propulsion
System

MPS-120 Test Results



- Isolation system demonstration testing conducted in June 2014
 - Machined aluminum isolation system test successfully conducted in March
 - 3D printed titanium isolation system test successfully conducted in June
 - Hermetic seal was verified prior to test
 - Isolation system operated at MEOP during testing to simulate flight condition
 - One of the two isolation devices failed to operate fully, but the root cause has been identified and minor design modification should resolve the issue
- Piston tank demonstration testing conducted in May 2014
 - 3D printed titanium tank was assembled
 - Water expulsing testing conducted
 - Entire pressure operating range was tested
 - Measured expulsion efficiency of >99% over 12 fill and drain cycles
- Future testing
 - One MR-142 engine was assembled and ready for hotfire
 - Anticipate system level hotfire testing in October 2014



MPS-120 Product Development is Proceeding with Positive Results

MPS-130 Demonstration Program



- MPS-130 is a 1U, AF-M315E green propulsion system
- MPS-130 uses same tank as MPS-120
- MPS-120 demonstration program will validate MPS-130 system design
- MR-143 1N, AF-M315E engine is unique to the MPS-130
- Aerojet Rocketdyne has been working with Plasma Processes, LLC on MR-143 engine materials development and demonstration on NASA SBIR Phase II program
- Program scope was to push the limits of El-form[®] materials

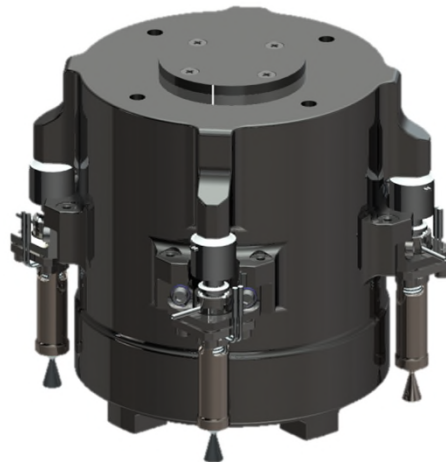

MPS-130

MPS-130 Test Results



- MR-143 hotfire test conducted February 2014
- Complete, flight weight MR-143 thruster assembled
 - EL-form® chamber, nozzle, injector, and catalyst
 - 3D printed stand-off
 - Brazed assembly
- MR-142 engine valve
 - Valve is not designed for long-term AF-M315E compatibility
 - Further testing is required to understand if the valve can be used for long missions, or if a design modification is required
- Hotfire testing was successful
 - Pre-heat demonstrated using flight-like swaged heater
 - Short duration hotfire achieved
 - Crack developed in thin-wall EL-form® tube, limiting test duration
 - All other EL-form® parts performed as expected
- Plan forward
 - Machined injector will be used in future engines

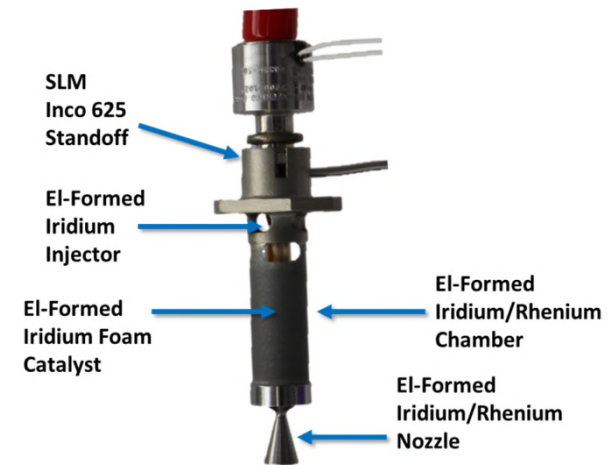

MPS-130 Product Development is Proceeding with Positive Results

Conclusions



- MPS-120 development is proceeding
 - Isolation system design and operation was verified
 - Piston tank design and operation was verified
 - MR-142 engine is assembled
 - Flight weight, system level hotfire testing planned for October

- MPS-130 development is proceeding
 - Isolation system design and operation was verified
 - Piston tank design and operation was verified
 - Flight weight MR-143 engine level testing conducted
 - Hotfire test demonstrated EL-form® material capabilities
 - Looking for opportunities to conduct system level hotfire demonstration

**Aerojet Rocketdyne is Maturing
Additively Manufactured, Modular Propulsion Systems
for CubeSats**



CubeSat Modular Propulsion System Key Technologies

MPS-100 Product Line Key Technological Innovations



- IR&D investments to commercialize missile defense technologies and develop new AF-M315E green propellant technologies have enabled miniaturized rocket engines capable of supporting CubeSat missions
- Additive Manufacturing of key components and primary structures enables packaging of propulsion system components into CubeSat volumes as well as lower cost fabrication and more opportunities for validation testing
- Integrated Solar Electric Power and Solar Electric Propulsion System (SEP²) based on experience with Direct Drive enables SEP for CubeSats

The MPS-100 Product Line Implements Technological Innovations that Enable Performance and Cost Advantages

Miniature Rocket Propulsion System Technology



- IR&D investments to commercialize missile defense technologies has enabled miniature rocket engines capable of supporting CubeSat missions
- IR&D investments have established system designs
- NASA and DoD program funding is increasing TRL of each system

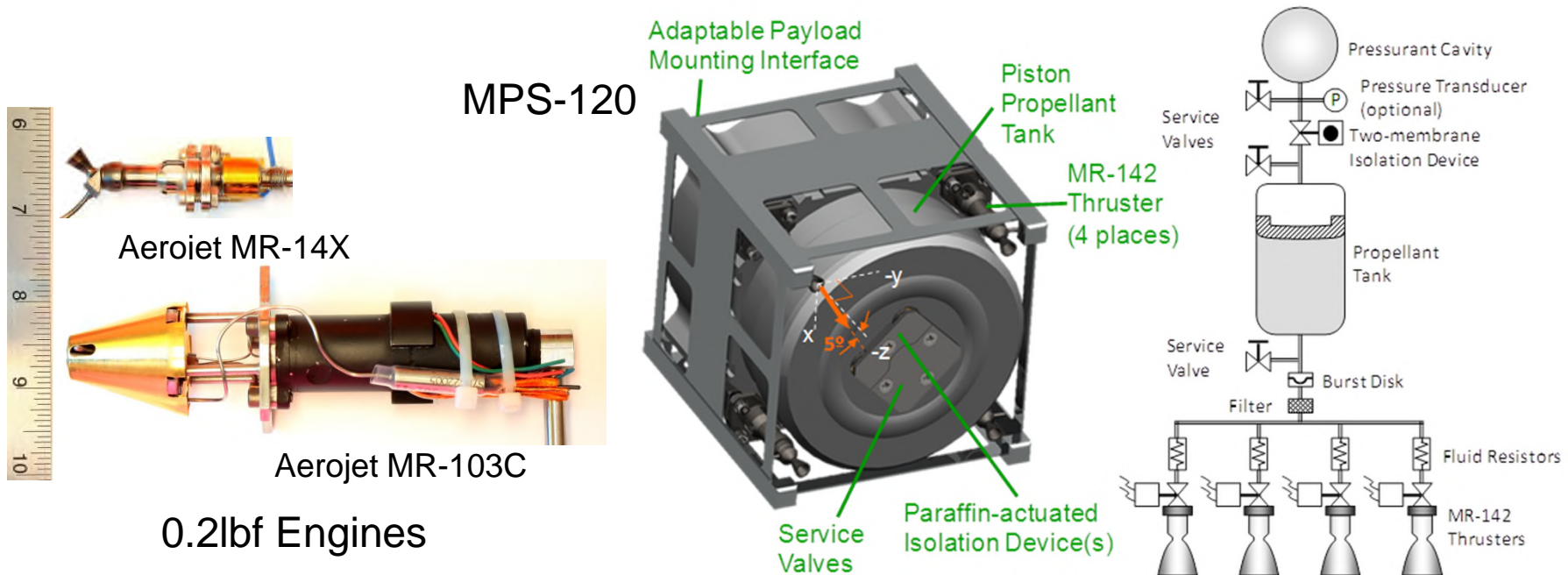

Recent Commercialization of Missile Defense Technologies and Aerojet IR&D Investments Enables CubeSat Modular Propulsion Systems

Infusion of Additive Manufacturing



- Aerojet Rocketdyne is developing technologies to significantly reduce cost and lead time for propulsion systems: Additive manufacturing was identified as a potential solution
 - Limitation: Most machines limited to 30cm³ build area
 - CubeSat product line identified as ideal test case due to size and complexity
- Candidate manufacturing processes were identified
 - Electroforming (EL-forming) for thin-walled components
 - Selective Laser Melting (SLM) for fine detail components
 - Electron Beam Melting (EBM) for metallic structural components
 - Laser Engineered Net Shaping (LENS™) for metallic and ceramic components
- Aerojet Rocketdyne established additive manufacturing demonstration programs for CubeSat Modular Propulsion Systems
- Additive Manufacturing has enabled highly efficient system integration of necessary components to support high-impulse propulsion systems in 1U form factor

Additive Manufacturing Enables Significant Improvements in Propulsion System Affordability, Responsiveness, and Size

Selective Laser Melting (SLM) and Electron Beam Melting (EBM)



- SLM and EBM deposit powder in layered fashion and apply laser (SLM) or electron beam (EBM) to sinter powder
- Inconel (SLM) and titanium (SLM and EBM) components produced
- Process for inspection and flight qualification is established

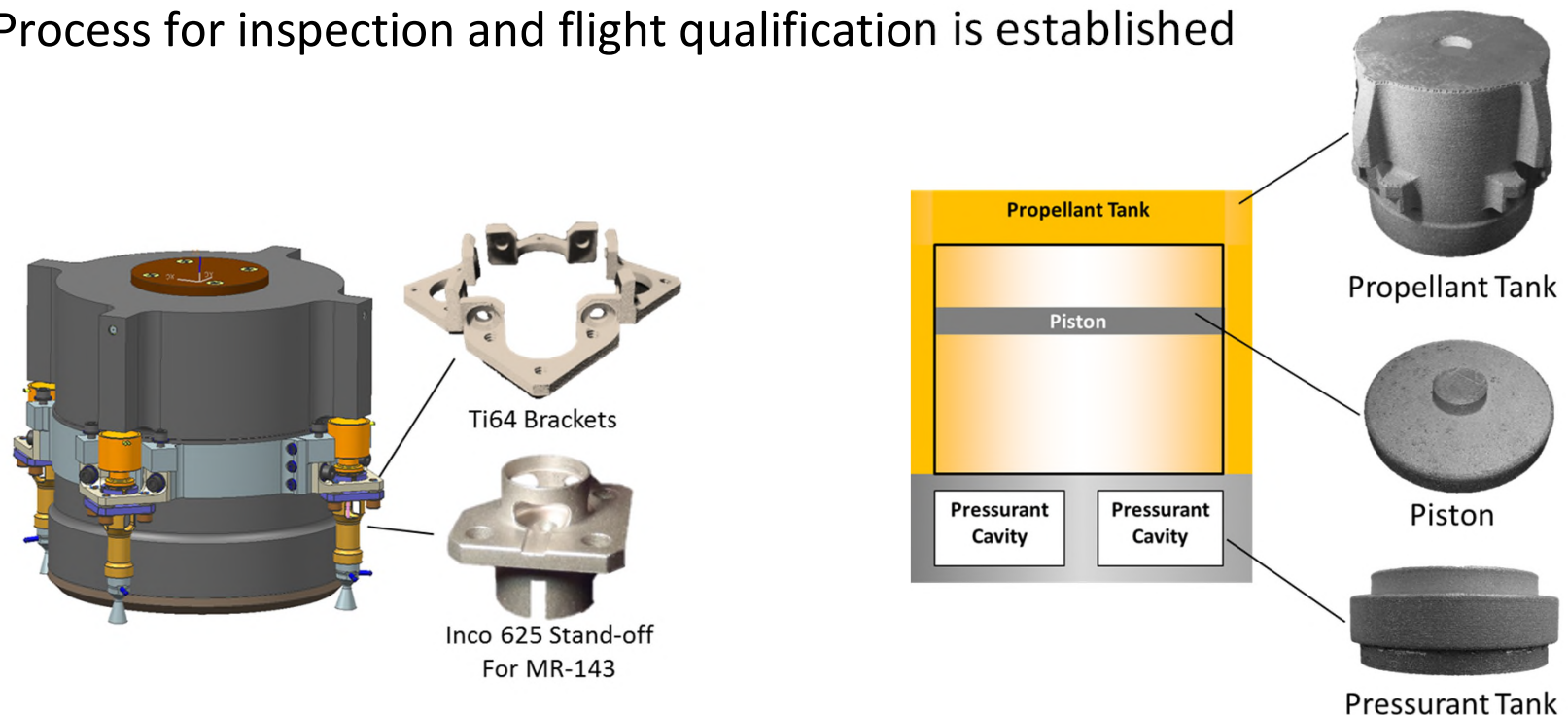

SLM & EBM Successfully Applied to MPS-100 Product Line

SEP² System Architecture



- Low ΔV EP for CubeSats has been offered by several companies ; however these systems have realized little mission utility.
- An apogee solar electric propulsion (SEP) system is desired that can provide significantly more ΔV than chemical systems
- Cost and mass of electronics in typical apogee electric propulsion solutions are prohibitive
- Integrated Solar Electric Power and Solar Electric Propulsion (SEP²) system enables low cost and mass electric propulsion for CubeSats

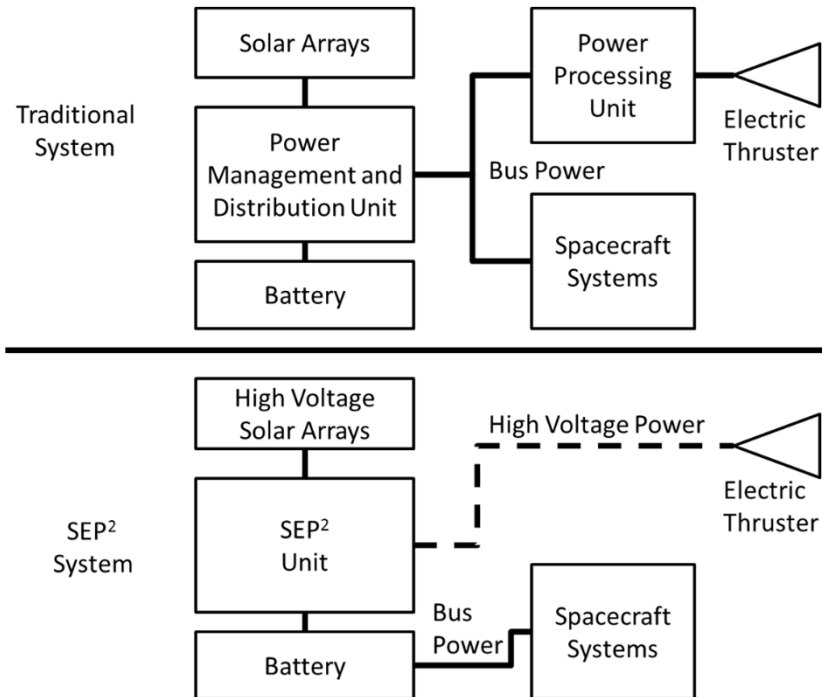

SEP² Architecture Enables Apogee Electric Propulsion for CubeSats



CubeSat Modular Propulsion System Capabilities

CubeSat Modular Propulsion System Capabilities



Mission Maneuver	MPS-110	MPS-120	MPS-130
Initial deployment /scatter (~5m/s)	~8kg	~160kg	~250kg
Constellation deployment & re-phasing (1/2 day, 500km maneuver)	6°	113°	180°
Drag make-up for low flight (90 day mission; min. altitude)	>289km	>200km	>190km
Orbital maneuvering (3U, 3.3kg mass SV) - altitude gained from LEO, km - altitude gained from GEO, km	13m/s 23 360	260m/s 480 8170	418m/s 800 14400
Satellite inspection/prox-ops		Capable	Capable
GEO operations		Capable	Capable
Formation flying		Capable	Capable

Near-Term CubeSat Modular Propulsion Systems Enable Significant Maneuvering Capabilities

Constellation Deployment/Re-Phase Capabilities

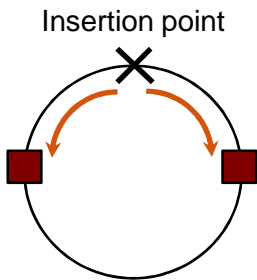

2 Satellites

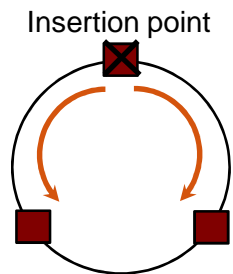

3 Satellites

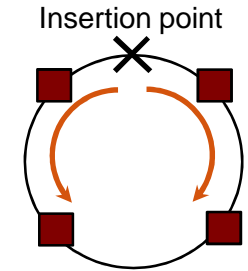
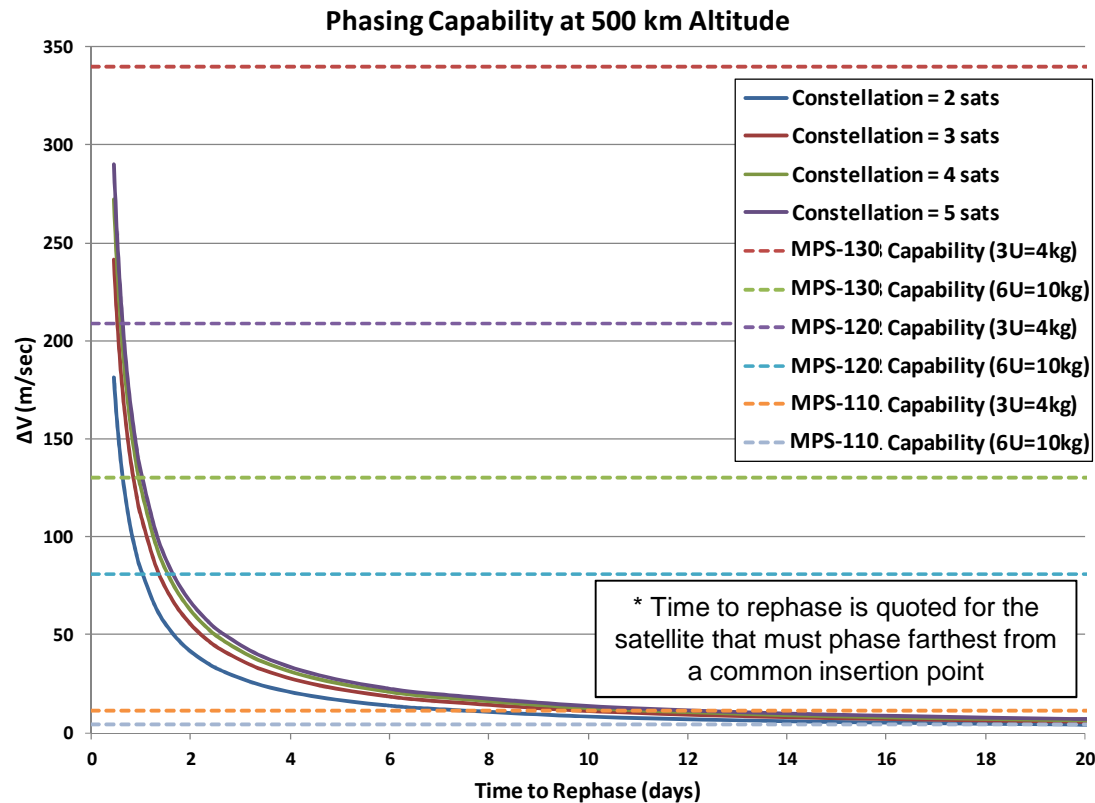

4 Satellites

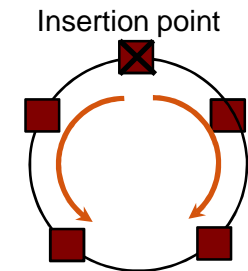

5 Satellites

Near-Term CubeSat Modular Propulsion Systems Enable CubeSat Constellation Deployment and Re-Phase Maneuvering

Conceptual Low Flying Imaging Satellite



- Resolution capability of 1.29 arc-sec with a Maksutov-Cassegrain two-mirror COTS optical system exist today:
 - Reference either Naval Postgraduate School TINYScope CubeSat or design study by University of Washington students below:
 - http://www.agi.com/downloads/partners/edu/UW_PDR_2009_paper.pdf
 - Optical system can fit within a 2U volume and weighs 1.68 kg with upgrade options to carbon fiber construction for lighter weight and less distortion due to thermal effects
 - Optical system compacts a 1.25 m focal length into ~20 cm with 9cm aperture diameter
- A CCD of at least 10 megapixels would be sufficient to capture images

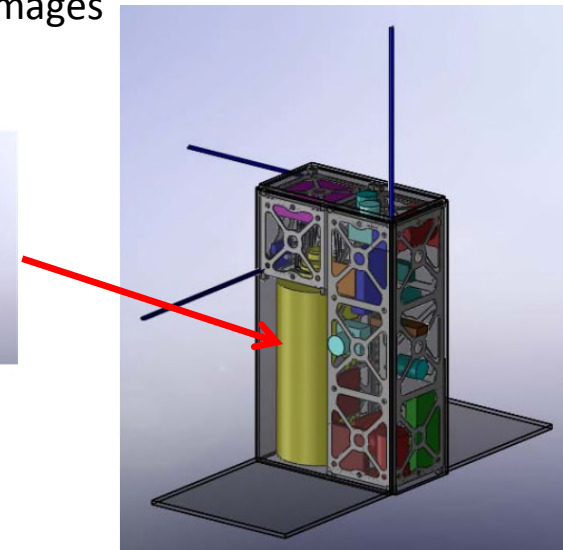
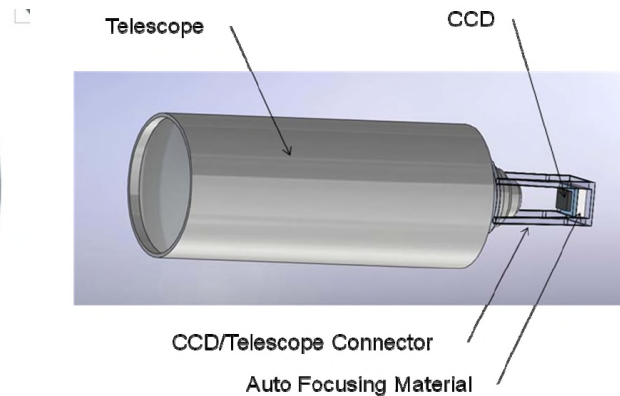

COTS Imaging Systems Can Fit In CubeSat Volumes

Low Flight Capabilities: Conceptual CubeSat Imager Mission



- Repeating ground track orbits can be used to support short and long-term change detection for global map data, crop management, climate monitoring, etc.
- Circular orbit at 262 km and 50° inclination (shown below) provides 1.7 m resolution capability with repeating ground tracks even after one month of operation
- Propulsion enables up to 9 months of mission life compared to less than a few days without propulsion
- 16 unique tracks, with 1 revisit per day; intersection points provide two revisits per day

Lifetime (days) for 6U (10kg S/C) at 262 km			
	MPS-110	MPS-120	MPS-130
Ballistic Coefficient = 50 kg/m²			
Solar Max	4.5	43.0	66.0
Solar Nom	11.1	183.4	286.9
Solar Min	27.5	402.0	626.9
Ballistic Coefficient = 200 kg/m²			
Solar Max	19.0	169.3	259.9
Solar Nom	44.0	776.0	1215.9
Solar Min	109.4	1712.5	2675.1

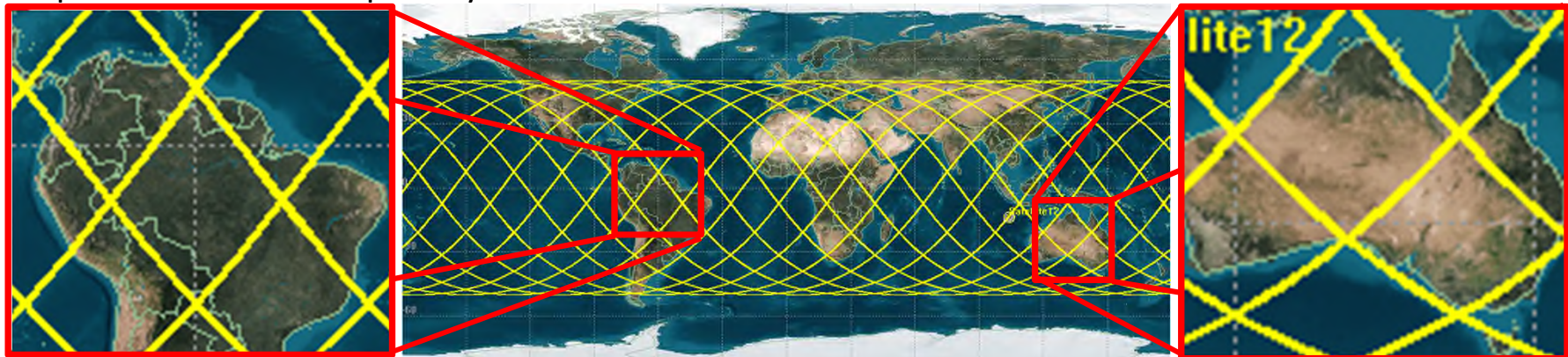

**CubeSat Propulsion Enables Repeating Ground Track Orbits At Low Altitudes
Providing a Niche for CubeSat Imagers**

Orbital Maneuvering Capabilities: Collision Avoidance



- Recent collision of Ecuador Pegasus CubeSat underscores need for propulsion capability to avoid debris stigma
- High-impulse propulsion system enables collision avoidance maneuvers and deorbit capability to mitigate growth of space debris due to collisions
- This also allows mission planners to design missions at higher altitudes without worrying about 25 year rule
- Will drive CubeSat component providers to manufacture components with increasing longevity to meet increasing mission lifetimes enabled by life-extending propulsion

6U CubeSat Life Map at Solar Maximum ($F_{10.7} = 300$, $A_p = 40$)

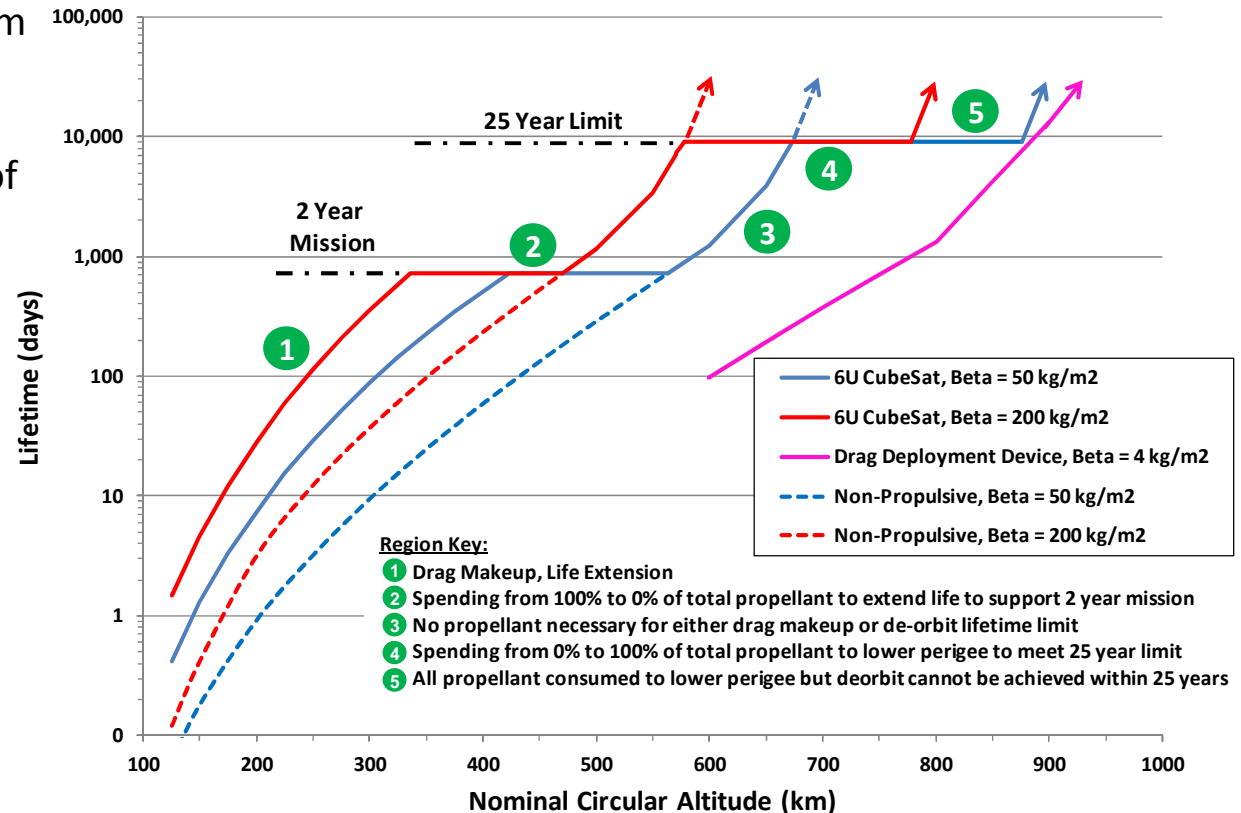

High-Impulse Propulsion Capability Mitigates Growth of Space Debris and Enables Longer Lifetime Missions

Orbital Maneuvering Capabilities: Low Thrust Missions



- ΔV is a function of BOL Storage pressure
- 1.5U tank, 3000s Isp offers significant mission capabilities at low pressures
- MPS-160 enables GTO rideshare CubeSats to access GEO and the Moon
- Further detailed study is needed to ensure reasonable trip times and payload masses can be achieved.

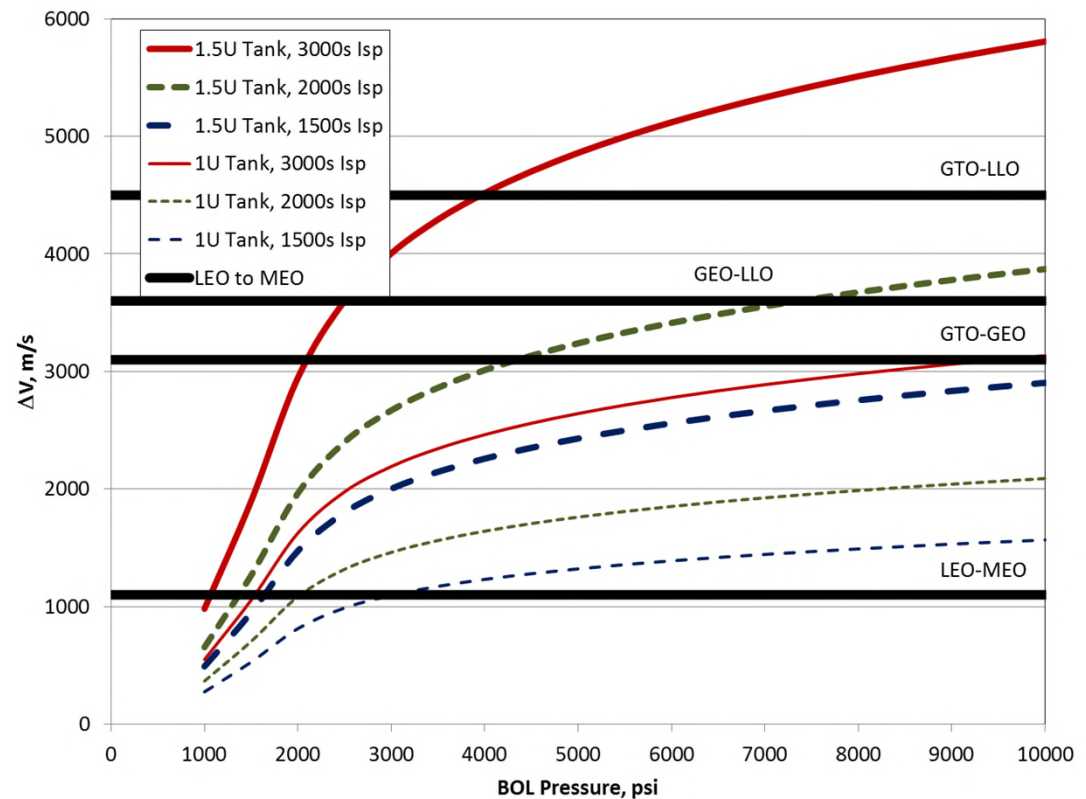

MPS-160 Potentially Enables GTO Rideshare CubeSats to Access GEO and the Moon

Summary



- A wide range of high-impulse propulsion solutions are required to enable the CubeSat platform access to newer, challenging, game-changing missions:
 - Imaging, Constellation Deployment
 - TPED
 - Collision Avoidance
 - High-altitude Deorbit Capability
- Additive manufacturing design philosophy has been applied to Modular Propulsion Systems for CubeSats product line to enable low-cost, volume-optimized systems

Aerojet Has Established Additive Manufacturing Capabilities for Modular Propulsion Systems

The logo for Aerojet Rocketdyne, featuring the company name in a bold, italicized sans-serif font. A stylized blue and red arrow graphic points upwards and to the right, positioned to the right of the text.

**AEROJET
ROCKETDYNE**

Backup Slides

Electroforming (EL-Form®)



- EL-Form® enables refractory metals to be formed into dense, non-porous and crack-free layers
- Molten salt electrolytes enable electrodeposition of compact metal layers onto a mandrel
- Can create component structures on mandrels and/or dense coatings applied to existing parts
- EL-Form® Ir/Re chamber and nozzle produced for MR-143 engines in MPS-130 system

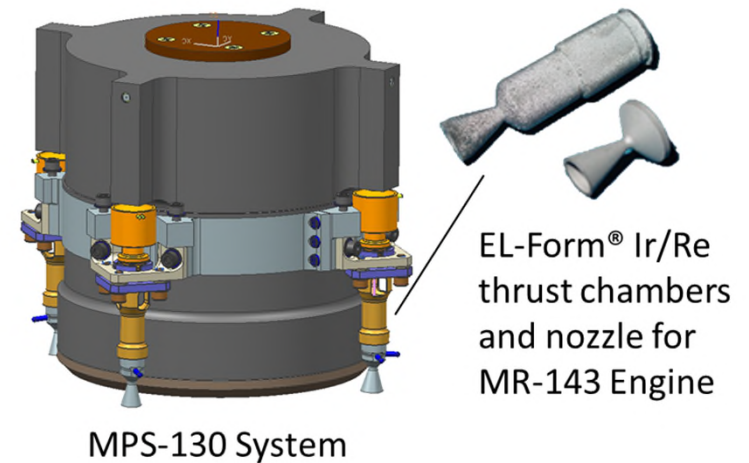

EL-Form® Successfully Applied to MPS-100 Product Line

Laser Engineered Net Shaping (LENS™)



- LENS™ simultaneously sprays and sinters powder, reducing need for powder removal
- Objective is to develop alternative to EBM for titanium parts with small passageways
 - LENS™ does not produce entrained sintered powder so cleaning process is significantly simpler
- LENS™ enables components printed from multiple materials
- Demonstration focused on printing MPS-130 tank (similar to MPS-120)

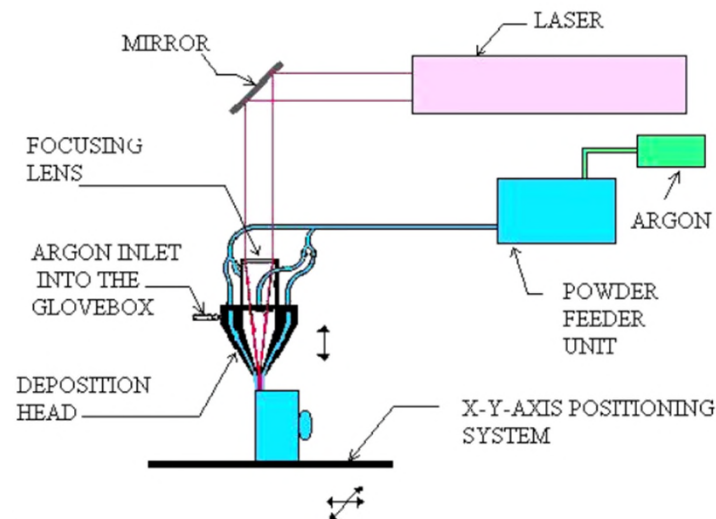

LENS™ Development and Evaluation is Ongoing

Additive Manufacturing Enables Significant Improvements in Affordability, Responsiveness, and Size



- Additive Manufacturing
 - Adds material layer by layer to fabricate parts from CAD data
 - Current machine limit of $\sim 30\text{cm}^3$ build envelopes insufficient for large systems, but supports full CubeSat Propulsion System
 - Significantly reduces manufacturing cost and lead time
 - Little/no tooling or setup, and option for embedded tooling
 - Consumes only material required by the part, eliminates cutting tools and fluids
 - Enables embedded features that greatly improves spatial utilization, manufacturing, and test capabilities
 - Enables standard offerings to be customized and qualified quickly and affordably

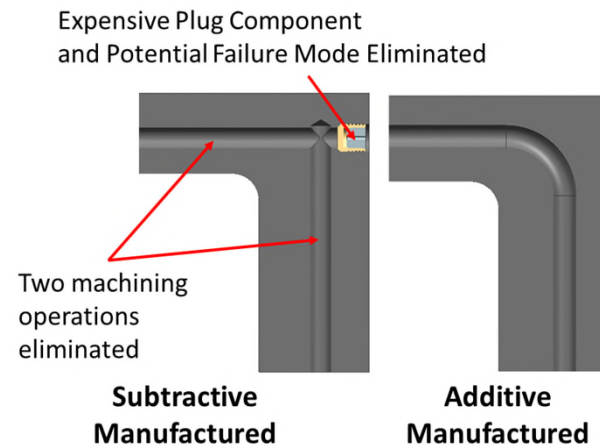
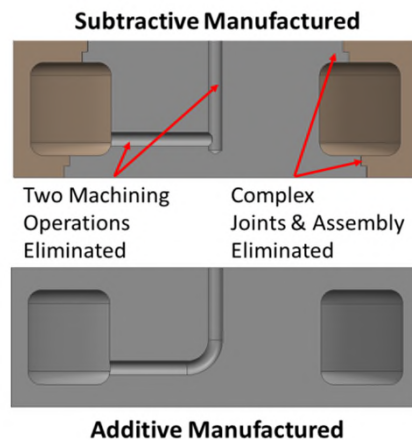

Aerojet has developed and applied additive manufacturing design philosophy to MPS-100 Product Line

Deploying Multiple Secondary Payloads



- CubeSat customers have a need to deploy multiple CubeSats from a single launch vehicle
- ~5m/s propulsion is required per CubeSat to enable satellites to escape the launch vehicle's orbit in order to prevent collisions due to coalescence
- Modular Propulsion Systems can be used as
 - A dedicated propulsion system to deliver single CubeSat/SmallSat
 - A stage to deliver multiple CubeSats

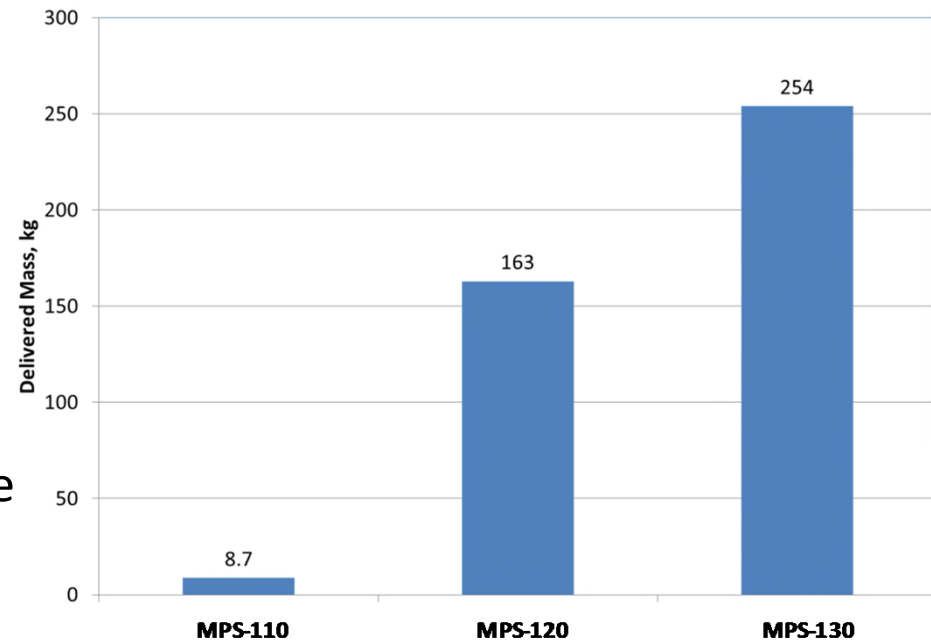

Near-Term CubeSat Modular Propulsion Systems Enable Deployment of Multiple Secondary Payloads

Counteracting Drag for LEO Missions



- CubeSat customers have expressed a desire for persistent LEO imaging and communications
- Propulsion is required to deploy and counteract drag in order to enable low flight and significant persistence

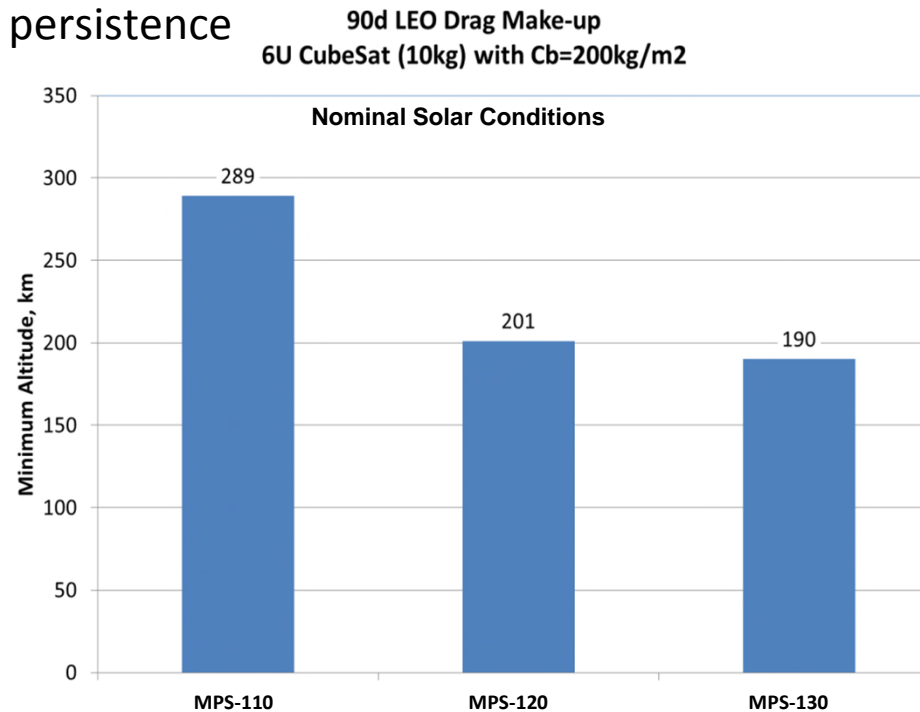

Near-Term CubeSat Modular Propulsion Systems Enable Persistent LEO Imaging and Communications Missions

LEO Imaging, Operational Responsiveness



- 3U and larger CubeSats will eventually be capable of being launched by dedicated nanosatellite and microsatellite launch providers



- Allows imaging satellite to select optimal orbit for specific area of interest
- This on-demand capability lends immediate tracking resources to organizations responsible for monitoring disaster situations like tornados, oil spills, forest fires, etc.
- Useful for situations where other space-based assets are either not accessible or too expensive to utilize in comparison to a CubeSat over the course of the expected disaster resolution timeline.

Operationally Responsive CubeSat Assets Will Provide Sufficient Imaging Capability at Low Cost

Tasking, Processing, Exploitation, and Dissemination



- CubeSats have historically been challenged with high data rate missions due to:
 - Difficulty of establishing reliable and repeatable communication links with ground stations
 - Limited power capability to support burst mode transmission when a ground station becomes available
- Recent successes with high gain deployable antennas offer the potential to communicate from higher apogee altitudes, where ground stations are more frequently within a given swath angle
- With the launch of NRO-36, the Aft Bulkhead Carrier (ABC) has been proven as a potential rideshare location for GTO dispersal
- Higher apogee orbits can be obtained with CubeSats by deploying in GTO and lowering perigee
- “Lock” in orbit at desired apogee altitude by utilizing apogee burn to raise perigee out of high-drag regime
- Depending on desired orbit, more efficient use of propulsion than orbit-raising burns from typical CubeSat LEO dispersal orbits

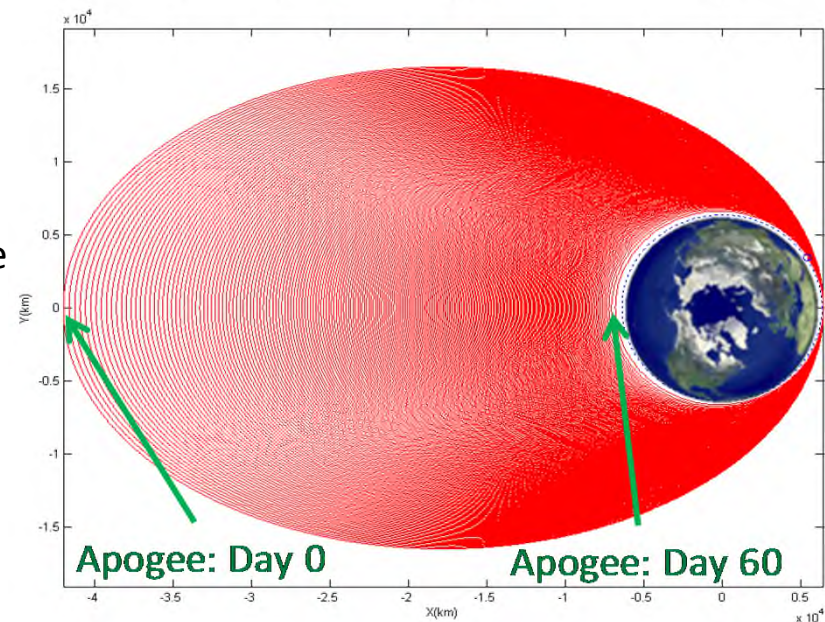

High-Impulse Propulsion Capability Provides Access to Any Apogee Altitude Orbit

Fluidic System Schematics



- MPS-110, -120, and -130 use common: filter, service valves, and propellant tank approach
- MPS-120 and -130 use a common isolation system
- Additive manufactured piston tank/structure scalable from 1U to 2U in length for “XL”
- All systems are compliant with AF-SPCMAN 97-10

