

EXAMINATION OF THE COMBUSTION MORPHOLOGY OF ZIRCONIUM CARBIDE USING SCANNING ELECTRON MICROSCOPY

Brian R. Newbold
Brigham Young University
Provo, Utah

Abstract

Calculation of viscous particle damping of acoustic combustion instability in solid propellant motors requires an understanding of the combustion behavior of added particles and oxides. A simple hydrogen/oxygen flame was used to ignite carefully sieved zirconium carbide particles which were impacted on slides at different levels below the burner.

Scanning electron microscopy revealed that zirconium carbide has a complex heterogeneous combustion morphology. Initially, particles are partly vitreous and crystalline with a complex surface area. Upon ignition, particles round, but soon wrinkle as zirconium oxide deposits on the surface. Such morphology information is useful to refine viscous damping calculations.

Background

Solid propellants and liquid propellants are the fundamental source of propulsion to space for current government and private interests. The twin boosters for the shuttle are an obvious example of solid propellant application. Solid propellant rockets offer advantages of high thrust-to-weight ratios, operational simplicity and safety, and low drag due to small frontal area (Oates, 1988). One drawback to solid propellants is their propensity to develop combustion instability which manifests itself as pressure oscillations in the combustion chamber. At the proper frequency and at a sufficient amplitude, such oscillations can modify the performance, damage the casing, disrupt the guidance system, or even cause catastrophic failure of the motor.

Combustion instability in solid propellant rockets has been studied intensely for over four decades but complete understanding remains elusive (Price, 1984). One solution to the stability problem has been the addition of fine metal particles to viscously damp acoustic oscillations (Dobbins and Temkin, 1967; Culick, 1974; Derr, 1976; Beckstead et al., 1984;). Yet consistent success in using particles as acoustic suppressants demands intimate understanding of a particle's morphology as it combusts. Such understanding facilitates predicting how the particles will interact with a motor's acoustic field.

As pressure waves wash back and forth across a suspended particle, energy of the wave is viscously dissipated since there is a no-slip condition at the particle's surface. Similarly, anyone trying to shout through a fog has noticed how his voiced is damped. In a rocket motor, the pressure oscillations driven by fluctuating propellant combustion may be damped by the addition of fine particles.

Viscous Damping (with Aluminum as an Example)

Aluminum dust was originally added to propellants to burn and thus raise the combustion temperature of the propellant and increase the specific impulse of a motor. An unplanned, but desirable, effect was the damping of pressure oscillations due to viscous damping. The aluminum has little viscous damping effect itself since it typically burns close to the propellant surface; although agglomeration or distributed combustion can increase the contribution of the burning aluminum particle to the viscous damping. The condensed aluminum oxide does effectively damp high frequency oscillations (Price, 1965). Besides reactive particles (such as aluminum or magnesium), inert or mildly reactive particles (such as titanium oxide or zirconium carbide) have been used as propellant additives.

The theoretical fundamentals of viscous damping by particles has been well established by many researchers, for example, Epstein and Carhart (1953), Dobbins and Temkins (1967), and Culick (1974). For a given flow condition, the essential parameters in predicting damping are a particle's size and density. If one were predicting viscous damping for combusting methanol droplets, basic calculations would be straight forward. Methanol's density is known, while droplet size in time could be predicted with a simple D^2 law. Since aluminum burns in a vapor-phase, similar to a hydrocarbon, one would think that predicting its damping effect (ignoring the condensed aluminum oxide) would be also straightforward, at least for a first approximation. Yet some experimental evidence indicates one must be careful with such approximations.

Aluminum particle combustion is often modeled as a molten sphere with a small oxide cap. The aluminum vaporizes and burns at a flame front around two to three

times the particles diameter (Prentice and Krauetle, 1968; Wilson and Williams: 1971, Pohkil, 1973). Aluminum oxide condenses to form small (around one μm) particles which constitute the white smoke so recognizable in the exhaust of a solid propellant motor. Some of the oxide condenses on the surface of the burning particle and forms a cap which is about 15 μm at particle burnout. This simple model allows for reasonable damping calculations to be made.

Yet experimental work by Friedman and Macek (1962), Drew and Price (1965), and Olsen and Beckstead (1996) indicate that hollow oxide spheres form on the particle during combustion. These "bubbles" have been seen under a microscope and a scanning electron microscope. If these spheres are present in solid propellant motors, corrections to the viscous damping calculations are necessary. The work of Olsen and Beckstead showed that a simple experiment can lend insight into the nature of a particle's combustion morphology and its consequent effect on viscous damping. Applying similar experimental efforts to the mildly reactive zirconium carbide particles was the goal of this research.

Zirconium Carbide

As early as 1976, zirconium carbide was used as an additive in the industry (Cohen, et al, 1976; Sambamurthi, et al, 1984). Although aluminum has been investigated extensively, zirconium carbide has received little experimental attention. Only Sambamurthi, et al. and Caulder (1989) have examined the carbide's burning behavior. Sambamurthi captured particles ignited in propellant samples. While Caulder

used thermal gravimetry.

Zirconium carbide's high boiling temperature, 5375 $^{\circ}\text{K}$, indicates combustion will occur at the surface heterogeneously. In heterogeneous combustion, minimal vapor phase oxide is formed. The oxide product forms as a liquid or a solid on the surface of the particle. The accumulating oxide impedes diffusion of oxidizer and the reaction proceeds slowly. For this reason zirconium carbide is considered inert in a low temperature environment and only mildly reactive in a high temperature environment. Since zirconium carbide has a high density (specific gravity of 6.73) and persists through a motor's volume, the compound is effective in damping lower frequency oscillations.

The current work burned zirconium carbide particles, nominally 54 μm in diameter, in a hydrogen/oxygen diffusion flame. Burning particles were captured at points below the flame and examined with a scanning electron microscope. It was hoped that examining the surface morphology of zirconium carbide particles coupled with X-ray analysis would lend insight into the particles' combustion behavior with subsequent understanding of their contribution to acoustic damping.

Experimental Approach

Twenty kilograms of zirconium carbide with a wide size distribution donated from Wah Chang Inc. was first sieved. In the -230/+325 mesh range, 25 grams of particles were recovered from the 20 kg of parent distribution. The left hand side of Figure 1 shows the

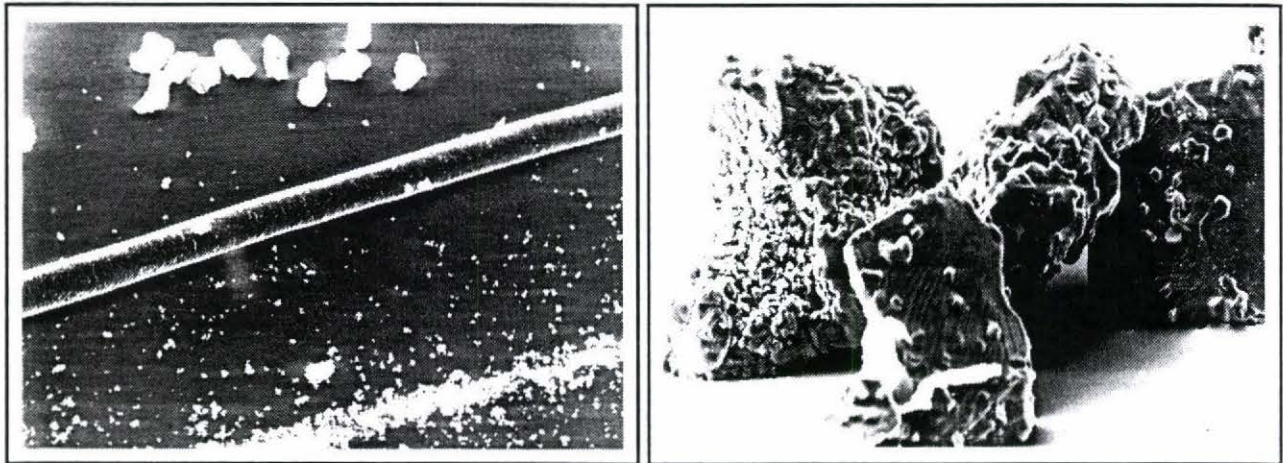

Figure 1. Left Side -- Scanning electron micrograph of zirconium carbide particles and a human hair for size comparison. In the lower right corner are unsieved particles as delivered by Wah Chang Inc. In the upper left corner are particles sieved between a -230/+320 mesh which yielded a nominal size of 54 μm in diameter ($\pm 9 \mu\text{m}$). The image is at a magnification of 70 times, taken at a 45 $^{\circ}$ tilt. Right Side -- "Close-up" view of the four zirconium carbide particles found in the upper left corner of the micrograph on the left side of this figure. This scanning electron micrograph of these four particles is at a magnification of 510 times, taken at a 70 $^{\circ}$ tilt.

unsieved and sieved ZrC with a human hair for scale. The right hand of Figure 1 is a close view of the larger particles. Note the glassy nature indicated by the curvy lines, much like obsidian. The geometric-shaped bumps also indicate some crystallinity. The greater surface area such complex surfaces create increases the viscous damping of the particle over that of a spherical particle.

A torch tip was modified to serve as a single particle burner as illustrated in Figure 2. To ignite particles and sustain combustion as long as possible, an oxygen/hydrogen diffusion flame was chosen. With the flame temperature at approximately 3100 °K, the zirconium carbide would melt at 2900 °K and ignite to burn in the mostly steam environment.

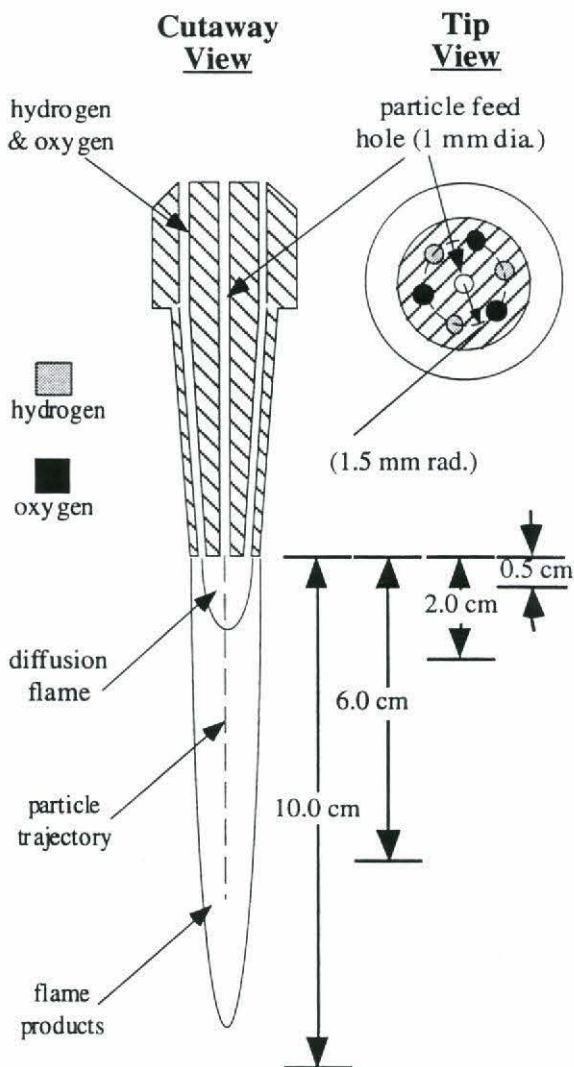

Figure 2. Schematic of the hydrogen burner with sample points.

A small stream of particles was introduced by a pipette into the burner. The particles dropped through the flame, ignited, and burned white hot through the flame's exhaust products, basically steam. Particles were captured by impacting them on No. 1 thickness glass slides at 0.5, 2.0, 6.0, and 10.0 cm below the burner's tip.

The captured particles were examined with a scanning electron microscope, model JSM 6100. With a light microscope, light is manipulated with glass lenses to magnify an image. A scanning electron microscope uses a high voltage electron beam, manipulated with electromagnetic coil "lenses" to magnify an image. With a scanning electron microscope, the target image must be electrically conductive. Since zirconium carbide and zirconium oxide are electrically insulative, the particles and slides were sputter coated with gold for five minutes from directly overhead and at an angle to establish a conductive path.

Besides careful coating, other steps were taken to minimize any electrostatic charge buildup on the particle samples. The scanning electron microscope was operated with an accelerating voltage of 15 KV, small probe current, and the smallest available aperture. Even with these techniques, charging was a difficulty and showed up as bright spots in the images. At least qualitatively, it was hoped that X-ray analysis would show the increasing amounts of oxygen (from ZrO_2) and decreasing amounts of carbon (from ZrC) as particles combusted. Unfortunately the X-ray analysis option was marginal due to a back-streaming pump oil problem which limited using the "no window" probe to be able to detect elements below sodium in the periodic table.

Experimental Results

Figures 3 through 6 show particles captured at the different sampling heights, and they are shown from an overhead and 70° angle. All images are magnified 540 times. Static charge buildup limited the quality of the micrographs.

The two particles in Figure 3 were captured at 0.5 cm below the burner tip and show little change from the unburned particles shown in Figure 1. It is possible that these particles had just ignited or were still heating since the diffusion flame was approximately at the same 0.5 cm distance. Yet at 2.0 cm from the burner tip, the particles shown in Figure 4 show a marked change. These particles had ignited and at least their surface melted. The roundness of these particles indicate that a spherical approximation of surface area for damping calculations may be acceptable. The cracks likely formed as the particles quenched.

At 6.0 cm below the burner, the impacted particle in Figure 5 shows another morphology change when compared to those at 2.0 cm. A convoluted surface is evident which is probably zirconium oxide, limited X-ray analysis confirmed this supposition. Note that the smooth surface of the particles in Figure 4 is still evident on the left edge of the particle that is shown in Figure 5.

Lastly, a particle collected 10.0 cm below the burner shows even greater surface convolution (Figure 6). Yet one can still see in the overhead view surface features reminiscent of the unburned zirconium carbide. Visually the "burned" particles were white and flaky. When probed with a needle, the surface would flake off revealing a dark steel color which matched the unburned particles.

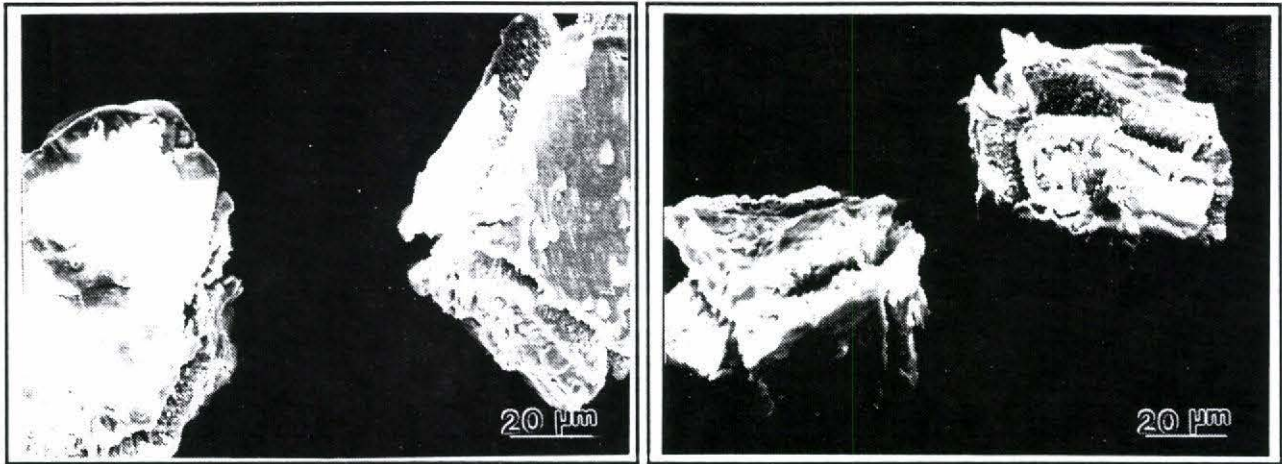

Figure 3. Scanning electron micrograph of combusting zirconium carbide particles impacted and quenched on a slide at 0.5 cm below the burner opening. It is likely that these particles had just barely begun combusting or were still heating since they were sampled at approximately the height of the flame front. The unburned particles were approximately 54 μm in diameter. The left image is directly overhead the particle while the right image is a side view at a 70° tilt. Magnification of the image is 540 times.

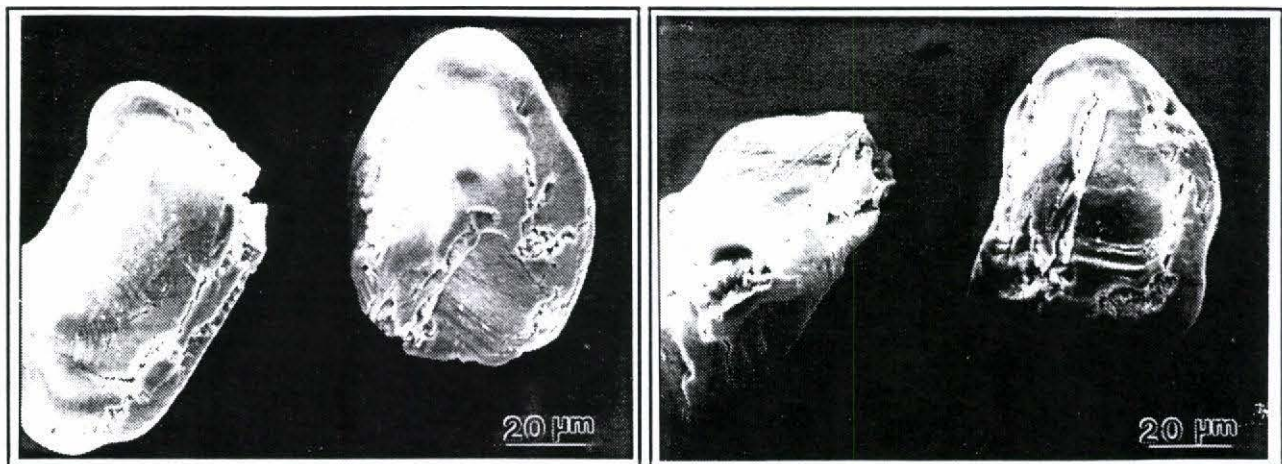

Figure 4. Scanning electron micrograph of combusting zirconium carbide particles impacted and quenched on a slide at 2.0 cm below the burner opening. The unburned particles were approximately 54 μm in diameter. The left image is directly overhead the particle while the right image is a side view at a 70° tilt. Magnification of the image is 540 times.

The particles probably only partly combusted due to limited contact time with the flame and the slow nature of heterogeneous combustion. Further study would require an experiment that could maintain high temperatures. Yet it is evident from this work that the surface structure of zirconium carbide undergoes complex changes during its combustion history.

It appears that successful damping calculations require a model that includes the deposition of zirco-

nium oxide on the surface of the parent particle. And a correction factor for non-sphericity might be in order. Scanning electron microscopy and X-ray analysis of zirconium carbide particles captured in an actual propellant condition would further refine this study. This information may be applied to making accurate damping calculations for a solid propellant with zirconium carbide as an additive.

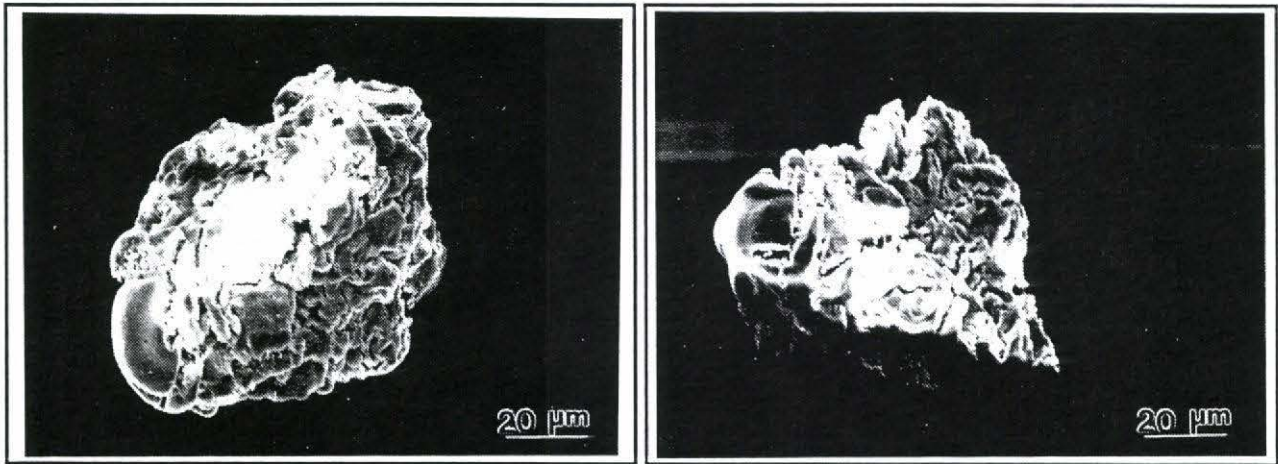

Figure 5. Scanning electron micrograph of combusting zirconium carbide particles impacted and quenched on a slide at 6.0 cm below the burner opening. The unburned particles were approximately 54 μm in diameter. The left image is directly overhead the particle while the right image is a side view at a 70° tilt. Magnification of the image is 540 times.

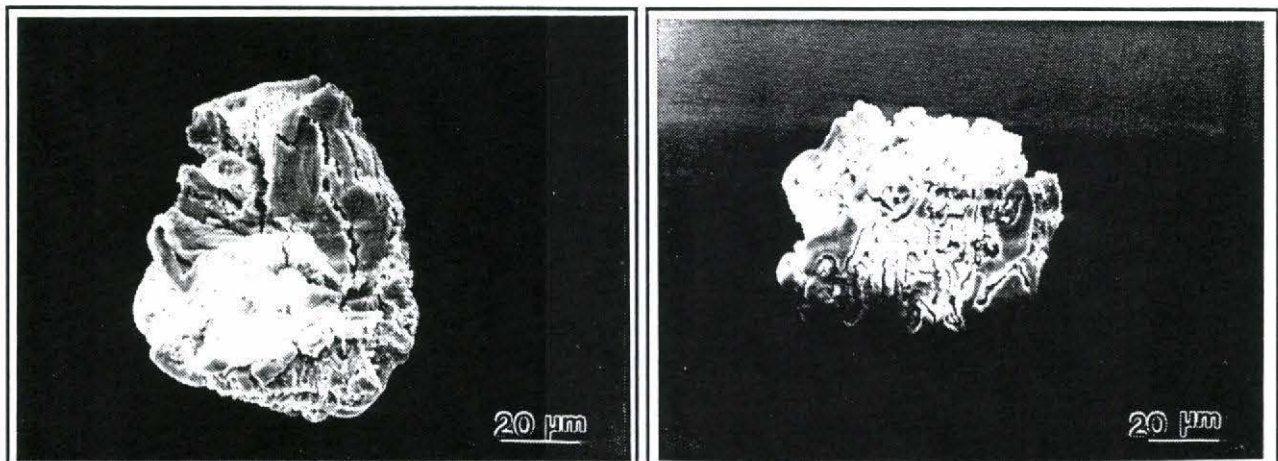

Figure 6. Scanning electron micrograph of combusting zirconium carbide particles impacted and quenched on a slide at 10.0 cm below the burner opening. The unburned particles were approximately 54 μm in diameter. The left image is directly overhead the particle while the right image is a side view at a 70° tilt. Magnification of the image is 540 times.

Summary

Acoustic combustion instability is a significant problem with solid propellant motors. Fortunately, several techniques, including particle addition for viscous damping, can usually minimize the effects of this instability. To accurately calculate the damping effects of particle addition, and consequent oxides, the combustion morphology of the particle must be known. Recent investigation by Olsen and Beckstead (1996) showed that even simple experimental techniques could offer insight into the complex nature of aluminum combustion. This study applied similar techniques to zirconium carbide which burns heterogeneously.

A simple hydrogen/oxygen flame was used to ignite carefully sieved zirconium carbide particles which were impacted on slides at different levels below the burner. Scanning electron microscopy revealed that zirconium carbide undergoes a complex combustion morphology. Initially, particles are partly vitreous and partly crystalline with a convoluted surface area. Upon ignition, particles are more rounded, but soon develop a wrinkled surface as zirconium oxide deposits on the parent particle. This behavior must be considered to make accurate viscous damping calculations.

Acknowledgments

This work was supported in part by the Rocky Mountain NASA Space Grant Consortium and Brigham Young University.

Literature Cited

- Beckstead, M. W., Brewster, B. S., & Richards, R. S., "Distributed Combustion Effects on Particle Damping," AIAA Journal, Vol. 22, No. 3, pp. 383-387, 1984.
- Caulder, S. M. & Turner, H. E., "The Structural and Thermal Characterization of Zirconium Carbide During Combustion," 1989 JANNAF Propellant Development & Characterization Subcommittee Meeting, CPIA 527, 1989.
- Cohen, J. & Zimmerman, G. A., "Smokeless Propellants with Stable Combustion," Chemical Abstracts, Vol. 83, Pt. 1, No. 12976Z, 1976.
- Culick, F. E. C., "T-Burner Testing of Metalized Solid Propellants," AFRPL-TR-74-28, AFRPL, 1974.
- Derr, R. L., "Combustion Instability in Navy Rockets . . . Revisited," 13th JANNAF Comb. Mtg., CPIA 281, Vol. II, pp. 185-194, 1976.
- Dobbins, R. A. & Temkin, S., "Propagation of Sound in a Gas-Particle Mixture and Acoustic Combustion Instability," AIAA Journal, Vol. 5, No. 12, pp. 2182-2186, 1967.
- Drew, Price, E. W., C. M., Christensen, H. C., Knipe, R. H., Prentice, J. L., & Gordon, A. S., "Aluminum Particle Combustion Progress Report," NOTS TP 3916, 1965.
- Epstein, P. S. & Carhart, R. R., "The Absorption of Sound in Suspensions and Emulsions, I. Water, Fog, and Air," Journal of the Acoustical Society of America, Vol 25, 1953.
- Friedman, R. and Macek, A., "Ignition and Combustion of Aluminum Particles in Hot Ambient Gases," Combustion and Flame, Vol. 6, pp. 9-19, 1962.
- Oates, G. C., Aerothermodynamics of Gas Turbine and Rocket Propulsion, AIAA, Washington, DC, pp. 4-5, 1988.
- Olsen, S. E. & Beckstead, M. W., "Burn Time Measurements of Single Aluminum Particles in Steam and CO₂ Mixtures," Journal of Propulsion and Power, Vol. 12, No. 4, Jul-Aug, 1996.
- Pohkil, P. F., Belyaev, A. F., Frolov, Yu. V., Logachev, V. S., & Korotkov, A. I., "Combustion of Powdered Metals in Active Media," FTD-MT-24-551-73, WP-AFB, Ohio, 1973.
- Prentice, J. L., & Kraetle, K. J., "Metal Particle Combustion Progress Report," NWC TP 4658, 1968.
- Price, E. W., "Experimental Solid Rocket Combustion Instability," Tenth Symposium (Int'l) on Combustion, The Combustion Institute, pp. 1067-1082, 1965.
- Price, E. W., "Experimental Observations of Combustion Instability," Progress in Astronautics and Aeronautics, Vol. 90, pp. 733-790, 1984.
- Sambamurthi, J. K., Price, E. W., & Park, C. J., "Combustion of Zirconium Carbide," 21st JANNAF Comb. Mtg., CPIA 412, Vol. 1, pp. 63-70, 1984.
- Wilson, R. P. Jr. & Williams, F. A., "Experimental Study of the Combustion of Single Aluminum Particles in O₂/Ar.," Thirteenth Symposium (Int'l) on Combustion, pp. 833-845, 1971.