

The Falcon Launch Vehicle – An Attempt at Making Access to Space More Affordable, Reliable and Pleasant

Elon Musk, Hans Koenigsmann, Gwynne Gurevich

Space Exploration Technologies Corporation

El Segundo, CA

310-414-6555 ext 229

gwynne.gurevich@space.com

Abstract

Falcon is a mostly reusable, two stage, liquid oxygen and kerosene powered launch vehicle being built by Space Exploration Technologies (SpaceX) from the ground up. The vehicle is designed above all for high reliability, followed by low cost and a benign flight environment.

Launched from Vandenberg, a standard Falcon can carry over 470 kg to a 700 km sun-synchronous orbit and a heavy Falcon can deliver 1450 kg to the same orbit.

To minimize failure modes, the vehicle has the minimum pragmatically possible number of engines (two) and stage separation events (one), as well as dual redundant avionics.

Since the first stage is recovered via parachute to a water landing, approximately 80% of the vehicle mass is reusable as compared with 90% for the Space Shuttle. The costs, which nominally assume no advantage for recovery, are \$6M for a standard Falcon and \$10M for a heavy Falcon.

First launch is scheduled for January 22nd, 2004 from Vandenberg, carrying a US government satellite.

The Falcon Launch Vehicle

Vehicle Design

The vehicle diameter is 66" (1.67m), tapering to 60" (1.5m) on the second stage, and length is about 70 feet (21m). Usable internal fairing diameter is 1.4m or 4.5ft on Falcon Standard and 2.4m or 7.5ft on Falcon Heavy. The first stage uses a turbo pump to feed the propellant, while the second stage uses a pressure fed system. Figure 1 shows the vehicle outline.

The first stage has a LOX/kerosene engine with 72 Klb (320 KN) thrust at sea level, increasing to 84 Klb (377 KN) at vacuum. The engine propellant is driven by a turbo pump, which is driven by a gas generator. A helium system is used to pressurize the fuel tank and, for the first seconds of the flight, the LOX tank. The turbo pump and gas generator are stage-mounted, and the main engine is gimballed by hydraulic actuators, using the high pressure kerosene from the turbo pump high pressure outlet. The "used" kerosene is recycled into the low-pressure inlet of the turbo pump. The gas generator outlet, which produces between 350 and 500 lb thrust, is gimballed to produce roll control torques.

An engine computer controls the engine startup and aborts if the gas generator, turbo pump or main engine show anomalous parameters. The engine computer also drives and controls the two servo valves of the gimbal system and collects (some) telemetry in the engine bay. The engine computer is connected to the flight computer in the second stage avionics bay with an Ethernet LAN.

The thrust frame (figure 2) carries the load into the skirt and the fuel tank. The fuel and LOX tank share a common bulkhead, and the LOX propellant line is an integral part of the fuel tank, similar to the Saturn-V design. The fuel tank, made of Al 2219, has a volume of 2180 gallons; The LOX tank has a volume of 3350 gallons and is, similar to the fuel tank, made of Al 2219. The inter-stage is mounted on top of the LOX tank and accommodates a parachute for the recovery and the engine of the second stage. Since the inter-stage is fixed to the first stage, the second stage has to fly out, pushed by pneumatic cylinders. The parachute fits inside the second stage engine and is thermally protected against the second stage plume.

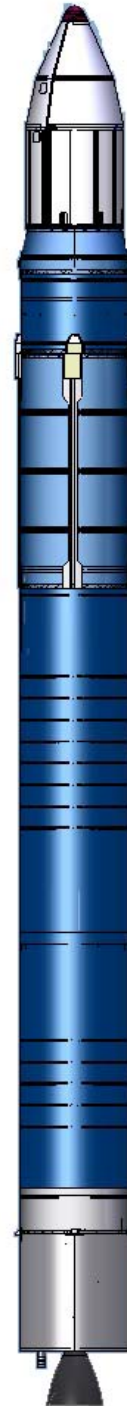

Figure 4: First Stage Engine Bay

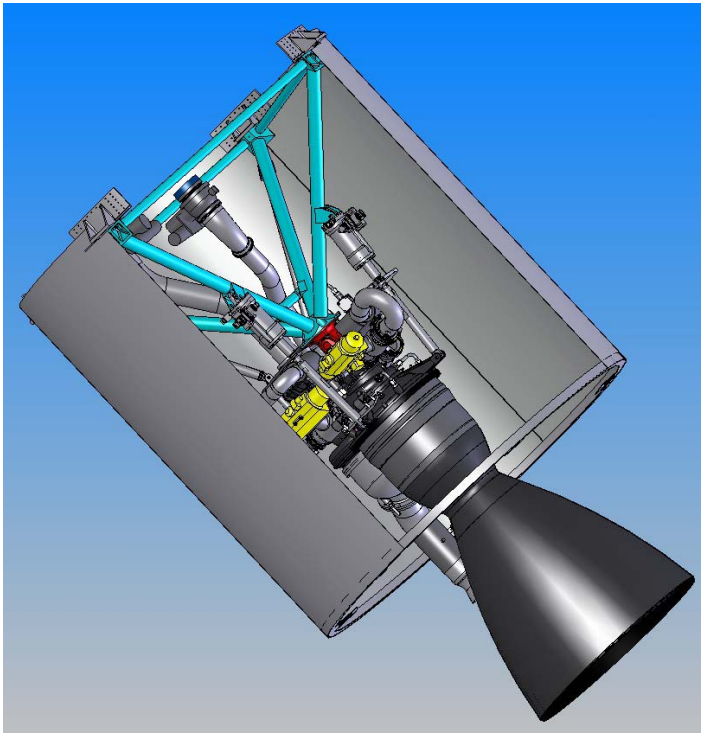
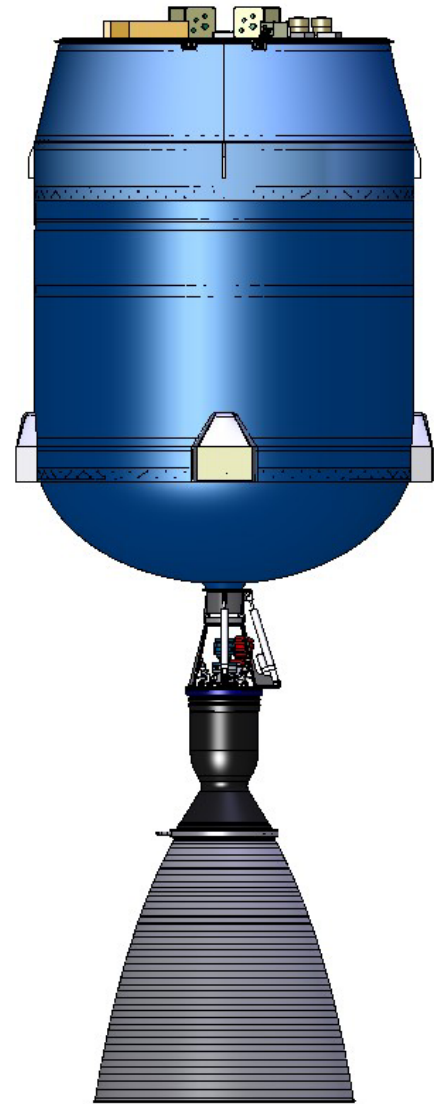

Figure 3: Second Stage Without Payload Adapter and Fairing



The second stage (figure 3) is pressure fed, using helium as pressure gas. The engine has 7500 lb thrust and an expansion ration of 60:1. This engine is gimbled by electrical actuators. Both propellant tanks are made of an aluminum-lithium alloy; the helium high-pressure tanks are composite tanks. Like the first stage tanks, the second stage tanks are a common bulkhead design with the LOX tank forward of the fuel tank. The pressure gas bottles are accommodated below the tanks, while the avionics bay is located on top of the tanks, under the payload adapter.

The avionics components include the redundant flight computer and IMU, which is a fiber-optical gyro/accelerometer unit. A GPS receiver provides navigational information and allows compensating for wind drift. The flight computer is a PC/104 based Intel-486 computer with analog and digital input and output*. The flight computer is to a large extent identical to the engine computer. The avionics system includes an S-band telemetry system, a video downlink, a C-Band transponder and other components. The flight termination system is next to the avionics system on a separate platform and includes 2 batteries, 2 command receivers, redundant safe and arm systems and ordnance distributed throughout the vehicle. The flight computer provides an interface to the payload via Ethernet.

* A new computer is being designed in parallel, tailored to our application

Figure 5: Avionics Bay, View from Below

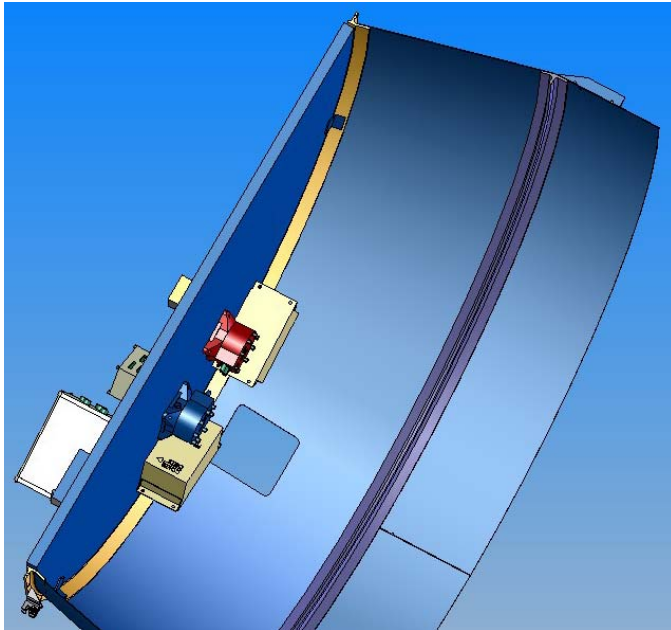
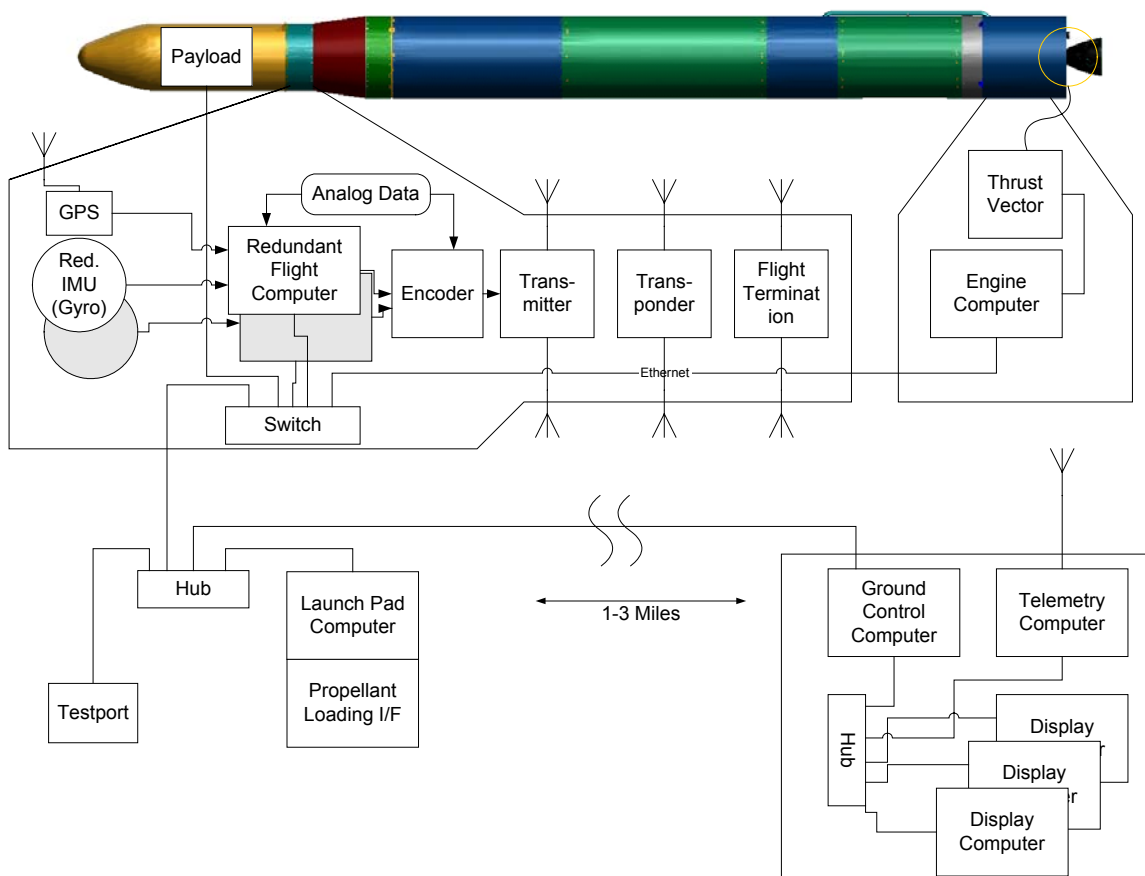

Figure 6: Avionics and Ground System Architecture



Trajectory and Performance

Three launch sites and a liquid propulsion system with re-start capability provide all the flexibility and performance required from a modern launch system. Figure 7 shows a typical trajectory from Vandenberg, where the launch pad is currently modified for the Falcon vehicle. Depending on the desired orbit and the payload, either a direct insertion or an orbital insertion into a lower, eccentric orbit with a second burn at apogee will be selected (2 impulse), see Figure 8. During the ascent, the maximum acceleration reaches approximately 6 g's, as shown in Figure 9.

Figure 7: Trajectory For a Typical Launch from Vandenberg. Vertical lines mark the first and second engine burnout.

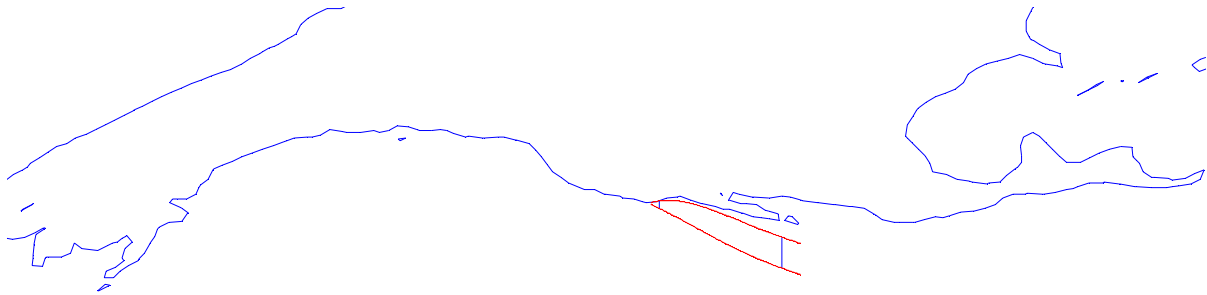

Figure 8: Falcon Performance for Circular Orbits Due East and Sun-Synchronous. The 2-Impulse data refer to an orbital insertion into an eccentric orbit with a second, short burn at apogee to circularize the orbit.

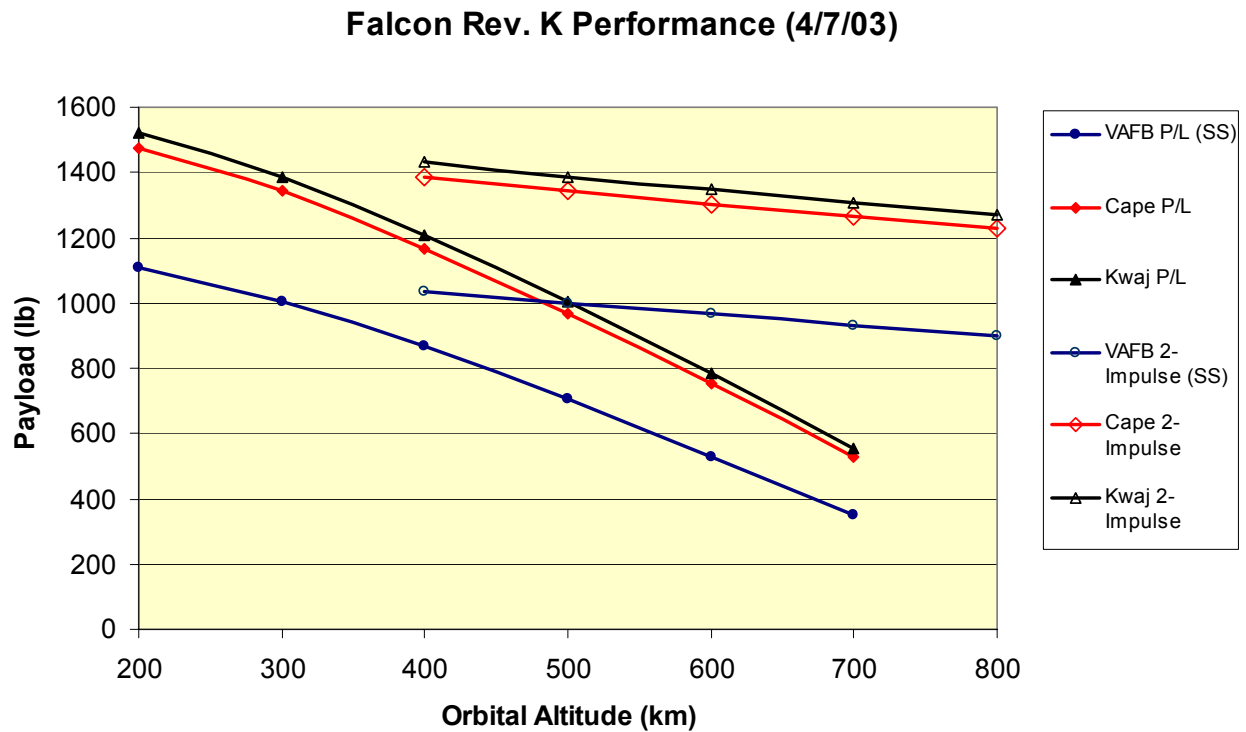
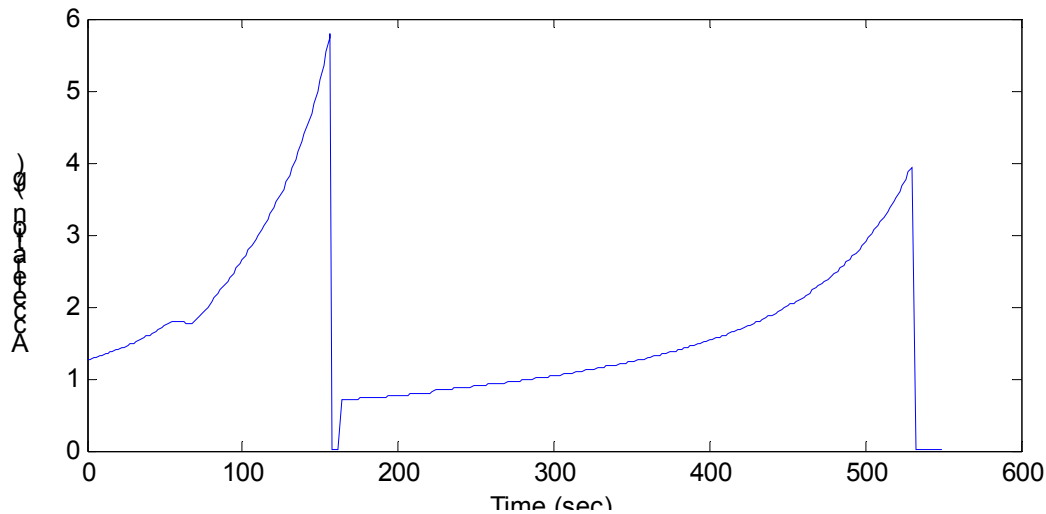

Figure 9: Acceleration For a Typical Ascent

The electrical interface consists of discrete commands, an Ethernet LAN and an RS-232 telemetry downlink. The Ethernet is intended for ground processing and vehicle checkout and provides the ability to check out the payload from virtually anywhere, given the appropriate software on board of the payload. During launch, the Ethernet is dedicated to internal communication. Also provided are pass-through cables on the launch pad for battery charging and other, payload-defined functions.

Payload Interface

Falcon was designed to provide payload customers with an extremely benign ride. Its all-liquid design with low thrust to weight ratio limits structural vibration and static loading. Acoustic blanketing is implemented which further reduces vibration and acoustic input. The Lightband separation system has demonstrated a factor of 10 reduction in payload separation shock. However, the major breakthrough is the use of a set of shock absorbers integrated into the payload cone – a patent pending SpaceX system.

In addition to a soft ride and accurate orbit injection, standard payload services include quick turnaround launch, launch site processing facilities, power and data through the T-0 umbilical, controlled environments throughout the integration process, and a controlled separation with spin-up if desired.

Falcon can accommodate large volume payloads for its class. Useable payload volume and the mechanical interface is shown below, Figure 10.

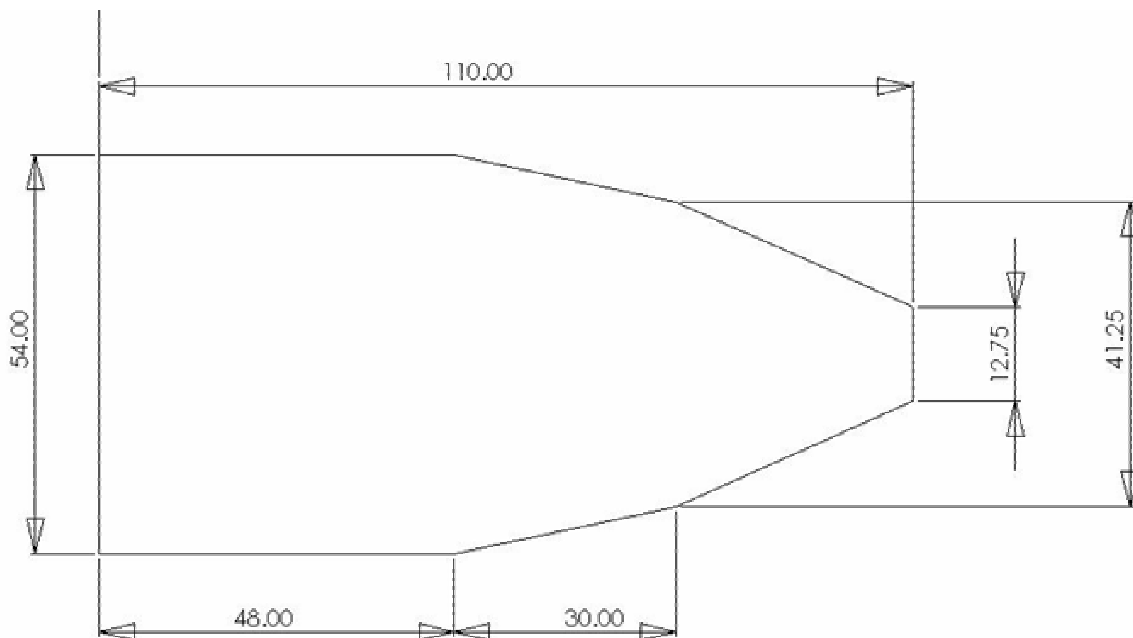
Figure 10: Payload Volume**Reliability**

Falcon is designed to maximize reliability by eliminating many known catastrophic failure modes at the system architecture level. The vast majority of launch vehicle failures in the past two decades can be attributed to three causes: engine, avionics and stage separation failures. An analysis by Aerospace Corporation[†] showed that 91% of known failures can be attributed to those subsystems.

It was with this in mind that we designed Falcon to have the minimum number of engines and separation events. As a result, there is only one engine per stage and only one stage separation event – the minimum pragmatically possible number. Moreover, the vehicle is held down after first stage ignition to verify engine operation before being released for flight. Immediate shutdown occurs if an off nominal condition is detected.

Where possible, proven and qualified components are used, such as premier quality LOX valves (same grade as currently flying on Delta IV upper stage). A robust qualification program is in place which includes repeated full vehicle hold down tests at our propulsion test site in central Texas. The avionics system has dual redundant IMUs and flight computers and is put through extensive hardware-in-the-loop testing. The flight computer and software are employed for every engine test, simultaneously proving the engine, electronics & software.

[†] <http://www.aero.org/publications/crosslink/winter2001/03.html>