

A STATUS REPORT LOCKHEED LAUNCH VEHICLE

for the
7th ANNUAL AIAA-UTAH STATE UNIVERSITY
CONFERENCE ON SMALL SATELLITES

D.E. Davis, J.W. Angeli¹, A.J. MacLaren²
Lockheed Missiles & Space Co., Inc

Abstract: This paper discusses a new family of small and medium space launch vehicles being developed by Lockheed Missiles & Space Company, Inc. The development program will culminate in a demonstration launch in November 1994. The paper gives a brief background and gives the program status as of the date of this paper. Supporting graphics are included.

Background:

Lockheed Missiles & Space Co, Inc. has been studying small space launch vehicles since 1987. The original approach then was to use surplus or excess ballistic missile assets, primarily the 1st and 2nd stages from the Poseidon C-3 missile as the basis, replacing the weapon system guidance and control with state of the art technology, and adding a 3rd stage with a Star 48 solid rocket motor. Although the approach was notionally attractive and the calculated reliability was over 90%, no users were found.

Motorola's announcement of the Iridium™ program in 1990 dramatically altered our approach. Motorola's imperatives were very clear: lowest possible cost, on demand launch, and outstanding reliability. When we worked through the alternatives, we concluded that reliability had to be as close to 100% as possible. A 90% to 95% reliability was unacceptable; we calculated that for program such as Iridium™ we had to self-insure, because the costs of insurance at 15 to 18 percent per launch would be unacceptable from a price strategy point of view. Thus we quickly discarded the ballistic missile assets approach, and reexamined approaches based on Thiokol's Castor 120™ which was then in development. We formed a

collocated product development team with the mandate to use our engineering, manufacturing, and flight test experience, *but* - and an important *but* - to be innovative in our approaches. For example we elected to use, as much as possible, existing hardware; to use aluminum structure rather than composites - although Lockheed builds much composite structure; and to simplify the way we do business.

We have streamlined our paperwork system. The product development team has informal reviews - informal in the sense that their are no dry-runs, and hand drawn graphics are acceptable. The technical caliber of the presentations is as professional as if it were our traditional government customer instead of just ourselves.

Rather than tell our prospective subcontractors *how* they should design their hardware, we have either accepted their specification or we have discussed our requirements and allowed them to suggest the solutions and write the specification. We have held an oral competition where the proposal was the viewgraphs and a one page letter on price. This has not been without some internal trauma and there have been replacements of personnel who could not cope with the new world order.

On January 8, 1993 Lockheed Corporation approved a company funded development program and demonstration launch in November 1994. We have submitted the required range documentation to both the Eastern Range (Cape Canaveral) and the Western Range (Vandenberg Air Force Base). The Air Force has approved our use of Space Launch Complex (SLC-6) at Vandenberg AFB. We are working with the Eastern Range and the Florida Space Port Authority at Cape Canaveral. We have

1. P.E., Member ASME 2. Senior Member AIAA

started discussions with the Office of Commercial Space Transportation (OCST) of the Department of Transportation (DoT) with respect to the relevant licenses required by the Commercial Space Launch Act (CSLA).

We completed our Preliminary Design Review (PDR) process in July, and have started fabrication of the first hardware designated for testing. We are on a clear track to meet the November 1994 launch date mandated by our CEO, Dan Tellep.

Launch Vehicle Description:

This section describes the design and system performance of this new family of launch vehicles designated the Lockheed Launch Vehicles.

The smallest vehicle (LLV1) will place about 2200 pounds in to a low Earth orbit (LEO) of 100 nautical miles at 28°. The next increment, (LLV2) will place 4000 pounds into LEO, and the LLV3 will place up to 8000 pounds into LEO. Launch operations will be conducted from Vandenberg Air Force Base in California for Polar and Sun Synchronous orbits and from Cape Canaveral. A mobile launch system checkout van will be provided which will allow launch operations from any suitable range.

Launch Vehicle assembly and checkout at the launch site is based on a simple stack and shoot approach allowed by the inherent simplicity of solid rocket motors. Only the Attitude Control System, which will be fueled prior to assembly on the pad, uses liquid propellant. The payload (spacecraft) will be mated to the payload adapter and release mechanism in a clean room. After payload checkout, the Fairing will be installed and the resulting Encapsulated Assembly will be moved and placed on top of the waiting solid rocket motors on the pad. Final preparation and check out on the pad includes installation of batteries, destruct arming devices and final electrical checks. The time from completion of payload receipt inspection

at the launch site to final countdown and launch is as short as two weeks.

The first of these vehicles is scheduled to fly from Vandenberg in November 1994. General operations will begin in 1995.

Solid Rocket Motors:

The LLV1 first stage is Thiokol Corporation's Castor 120™ Solid Rocket Motor. It is a 120,000 lbm class motor that employs a graphite epoxy composite case, Class 1.3 HTPB propellant, pyrogen igniter, and a vectorable nozzle driven by a cold gas blow down thrust vector control system. This motor is used as both the first stage and the second stage on the LLV2 and LLV3. As a second stage motor, a larger expansion ratio nozzle is used in order to improve performance at higher altitudes. The propellant grain can be tailored to change the burn characteristics and thrust history. This provides the ability to taper the thrust of the second stage near burn out, which lowers the vehicle acceleration and provides a smoother ride for the payload.

The upper stage of the LLV family is the Orbus 21D solid rocket motor manufactured by the Chemical Systems Division of United Technologies, Inc. The Orbus 21 is a proven motor which has been used in the Inertial Upper Stage on 17 flights. For use on the LLV it will use a carbon phenolic nozzle and an electromechanical actuator.

Castor IVA™ solid rocket motors may be strapped on to the LLV family of vehicles to increase payload to orbit capability.

Attitude Control System

The Orbital Assist Module(OAM) is located above the Orbus 21D. It contains the LLV Flight Electronics, Batteries, Telemetry, Inertial Measurement Unit, and the Attitude Control System (ACS). The ACS is a liquid monopropellant hydrazine propulsion system which has 10 rocket engine assemblies for pitch, roll, yaw control and velocity addition to correct for any errors induced during solid

rocket motor boost flight. The ACS may be configured with 2, 4 or 6 hydrazine tanks so that the propellant load may be tailored to the specific mission. Fuel load with the modular tanks is 260, 520, and 780 pounds. The ACS is manufactured by the Rocket Research Company which provides four 50 lbf axial thrusters for velocity addition and six 25 lbf thrusters for pitch, yaw and roll control. The hydrazine tanks which are spun aluminum with a graphite composite overwrap, are pressurized with gaseous nitrogen to 460 psig and contains a elastomeric bladder for positive expulsion of the fuel. The ACS system may use up to 98% of the fuel on board at an average specific impulse of 220 seconds. The total impulse available is 57,200 lbf sec. All components of the ACS have a proven flight history which minimizes development cost and program risk.

Guidance, Navigation & Control

The heart of the LLV Guidance, Navigation and Control (GN&C) system is the Litton LN-100L Inertial Navigation Unit (INU). This is a strap down system which employs a nondithered Litton Zero-lock™ Laser Gyro (ZLG™) and A-4 accelerometer technologies together with a sophisticated 24-state Kalman filter. This is a low cost, advanced technology INU with flight demonstrated performance of 0.4 to 0.6 nmi/hr (CEP) which validates simulations and exceeds SNU 84-1 type medium accuracy requirements. This unit is derived from a commercial unit and has been designed for Military aircraft and launch vehicle requirements. Less than 500 cubic inches in volume, it weighs 18.5 pounds and uses 27 watts. Predicted mean time between failures is greater than 5,500 hours during boost phase and 26,000 hours during space flight coast phase. No scheduled calibration is required. The sensitivity of this unit allows the LLV to place a typical payload within one nautical mile

of altitude and 0.02° inclination of the desired orbit.

Payload Accommodations

Of specific interest to the potential user of a new launch vehicle are the payload accommodations features. These accommodations consist of the fairings, payload adapters and release mechanisms, on pad air-conditioning, T-0 umbilical and support equipment interfaces and electrical interfaces providing telemetry monitoring capability before and during flight. The LLV offers some unique features in this area.

The LLV family has been designed with the underlying theme of reducing system cost. This is especially reflected in the selection of available fairings range from a 92 inch diameter fairing intended primarily for the LLV1 to the 141 inch fairing for the larger vehicles. The fairings are of a two piece clam shell design. Zip tube, a patented clean system, cuts the base and two halves allowing springs to provide the separation forces. The increased volume of these fairings, which are large for this class of launch vehicle, simplifies the satellite packaging requirements for deployables such as solar arrays and antennas. There is, however, a performance penalty due to the increased weight and drag of the larger fairings, therefore the small fairing is designed for use with all three vehicles, while the 116 inch diameter fairing and the 141 inch diameter fairing can be used on either the LLV2 or LLV3. Should a payload nearly fit within an envelope, but violate it at a few isolated locations, specific accommodations are potentially available. The fairings are equipped with access doors and RF windows which are located per the satellite requirements.

The approach to the payload interface adapter design maintains the flexibility required to meet varied needs of payloads. It features a fixed conical adapter section reducing the 92 inch diameter of the equipment section to a

standard 66 inch bolt circle. This interface is compatible with existing payload adapters and separation mechanisms which several satellite manufacturers have developed for use with other systems. For smaller satellites, the cone can be extended to reduce the diameter to be compatible with the 38.8 inch marmon clamp system frequently used. Alternatively, we will offer a range of adapters based on the requirements of the early flights. For vehicles using the larger fairings, the equipment section diameter can be extended upward to a 92 inch diameter interface providing a more efficient load path. The mass properties book keeping procedure assigns the weight of the adapter and separation mechanism up to the payload interface to the launch vehicle for purposes of performance calculations. Adjustments will be made should the satellite choose to provide the adaptor/separation mechanism.

Umbilical connectors, which are pulled at separation, provide the electrical interface to the LLV avionics and a pass through to the T-0 umbilical. For spacecraft T-0 umbilical functions, there are 74 shielded copper circuits of several wire gauges. These circuits are carried through the equipment section and the fly away umbilical to a utility room located beneath the launch pad. From there they may be routed either to the launch control van via a two way fiber optic data system or to local equipment per the satellites requirement. Routed along with these circuits are two fiber optic cables which can be used by the satellite to provide a high data rate path with the satellite. These can be used for memory verifications and other operations which are frequently limited by the bandwidth of the launch pad data link. They include analog monitors for battery voltages, pressures, etc. discrete on/off indications, and signal conditioned continuity lops which may be routed through the satellite to provide reset or safe loop indicators. These are in addition to the separation indicators which are dedicated to that purpose.

There are commands which can be generated by the flight computer in accordance with satellite specified criteria. These can be used to initialize satellite inertial reference systems, open shutters, or similar spacecraft functions requiring actuation prior to separation.

Flight Environments

The environments experienced by the payload during flight on a LLV are similar to those of other launch vehicles. Because the LLV design utilizes existing solid rocket motors, the axial static load is larger than for some liquids. It varies depending upon ascent trajectory and payload mass but does not exceed 8g. The lateral load maximum of 2.5g is below those of winged launch vehicles and is comparable to liquids. The dynamic loads associated with motor ignition and stage separation are below these limits and are not additive to the static load. The stiffness required of the satellite and the adaptor interface is 15 Hz for the LLV1 to avoid coupling with the structural modes of the launch vehicle. The requirement for LLV2 and LLV3 will be lower due to the increased vehicle length but have not yet been calculated.

Acoustic environment for the LLV1 was developed using measured data obtained during test firings of the Castor 120™, our database from firings using ducted pads similar to those planned for LLV, flight data from similar fairings and the VAPEPS computer code. The relatively low level derives from the small size of the vehicle and the use of a ducted pad. The acoustic environments for LLV2 and 3 have not yet been estimated but are anticipated to be similar or lower due to the increased height of the payload at launch and the lower maximum dynamic pressures during flight.

The pyro shock environment is developed at separation of the nose fairing, ignition and separation of the Orbus 21D and payload separation. It is based on measured test data for the

respective sources scaled to reflect the coupling path.

Stack and Shoot Approach

One of the key advantages of the minimal complexity of the LLV manifests itself at the launch base. The modular design produces a minimum number of systems which must be integrated and verified. The solid rocket motors and interstages are shipped directly to the launch pad for assembly. The Orbit Adjust Module is checked-out at the factory and delivered directly to a propellant loading facility where the ACS hydrazine propellant is loaded. Using methodologies developed to process ballistic missiles (over 1100 launches), the assembly process of an LLV1 is planned for a span of 14 days, the LLV2 and LLV3 taking slightly longer.

Requirements for interactions during payload and launch vehicle processing have been minimized. The payload processing span can be as long or as short as necessary to meet the payload requirements. When ready, it is mated to the payload adaptor and fairing are installed in the payload processing facility. The encapsulated payload is then delivered to the pad for mating with the launch vehicle just 3 days before launch. Filtered air-conditioning maintains both the temperature and cleanliness of the payload on the pad.

Performance

Two profiles for injecting a satellite payload into orbit are available. Direct injection is applicable to low altitude circular or parking orbits and for elliptical orbits. If a higher altitude circular orbit is desired, the indirect injection profile provides greater mass to orbit capability. With this technique, the satellite is directly injected near perigee of an elliptical orbit with apogee at the target orbit altitude. When apogee is reached, one-half orbit later, the OAM thrusters are used to raise the perigee to provide a circular orbit at the targeted altitude.

The LEO payload capability to various inclinations for the LLV1 is shown in a following figure. The effect of adding the second Castor 120™ to make an LLV2 is also shown. Since the payload interfaces and much of the vehicle are common for all configurations, this provides a satellite developer with a new option should his payload increase in weight beyond the capabilities of the intended launch vehicle. For the minimal incremental cost of adding the second stage, approximately 2500 additional pounds of capability is available. This often is less than the cost of a weight reduction program or compromises in satellite capability. The concept of incremental performance increases continues with the LLV3. Castor IVAs are added in quantities of 2, 3, 4, and 6 to provide performance increases of 1400, 660, 600, and 1010 lb. respectively.

Summary

The new family of launch vehicles described in this paper is being developed by a team led by Lockheed Missiles and Space Company. The design maximizes the use of existing hardware to lower development cost and shorten the time between concept and production. The first demonstration flight is scheduled for 1 November 1994 from Vandenberg Air Force Base in California. The design is based on a modular concept where solid rocket motors are assembled in various combinations to cover a range of payload requirements from 1000 lbm to 8000 lbm to LEO. This approach allows the user to select a propulsion system that just fits his needs. It also allows the user to move up to a slightly larger launch vehicle if a change in Mission requirements causes payload weight to grow. This can be accomplished without facing completely new design interfaces and environments caused by moving up to a new class of launch vehicles.

Solid rocket motors also provide a great deal of operational flexibility. They are ready to launch when the payload is ready. The stack and shoot

approach minimizes the time spent at the launch site, lowering cost for the launch vehicle as well as the cost of the payload final assembly and check out team. The launch vehicle is ready and waiting on the payload rather than the other way around.

Bibliography:

Solid Rocket Motor Space Launch Vehicles. A.J. MacLaren & H.D. Trudeau, *Acta Astronautica* Vol 30, pp. 165-172, 1993 Pergamon Press Ltd

Lockheed Thinks Small Donald F Robertson, *Space*, June 1993, pp.24-26

Ball Drops Pegasus Plan. Selects Lockheed Launcher. James R. Asker, *Aviation Week*, Jul 19, 1993



LLV1 PERFORMANCE

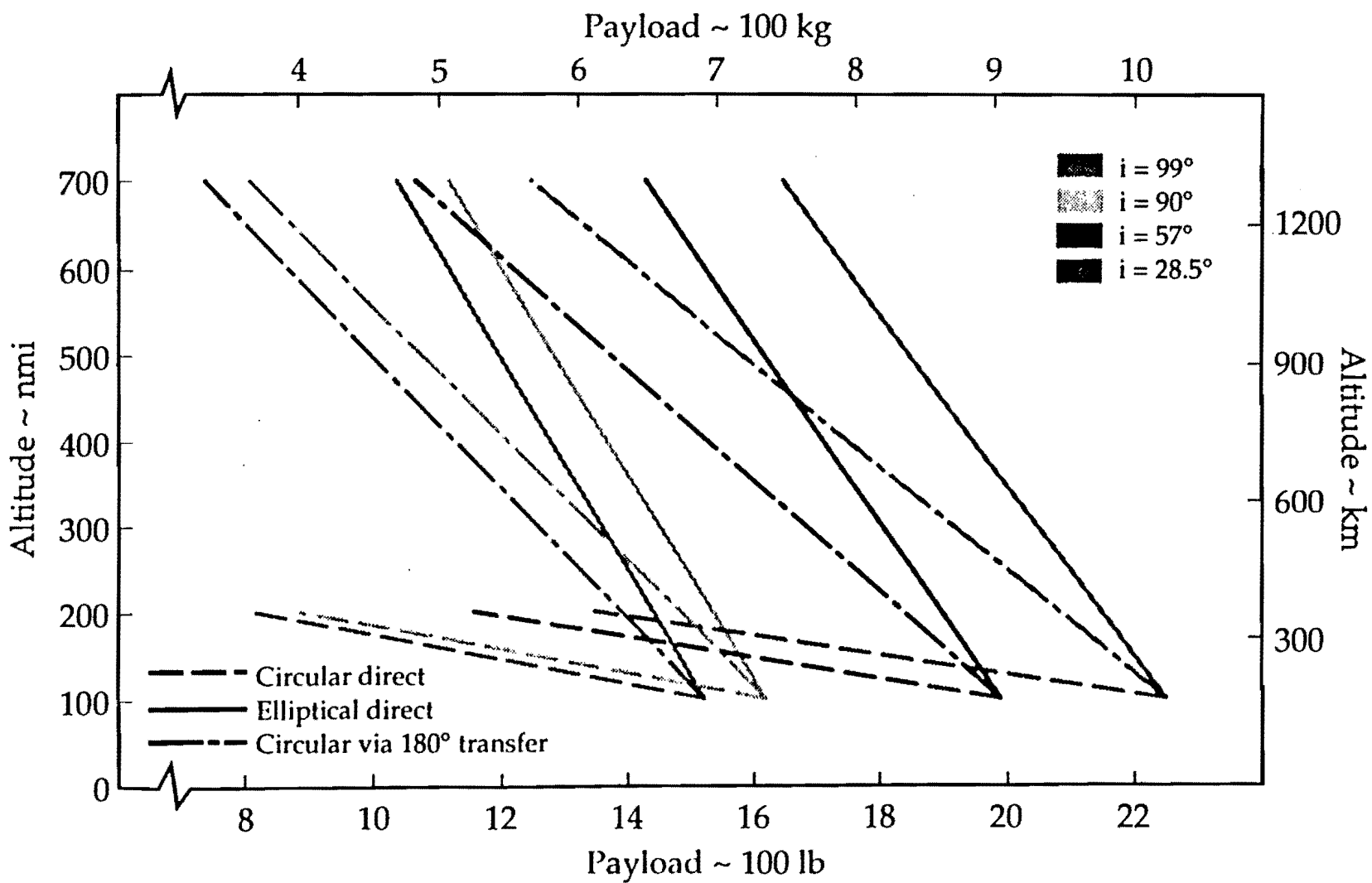

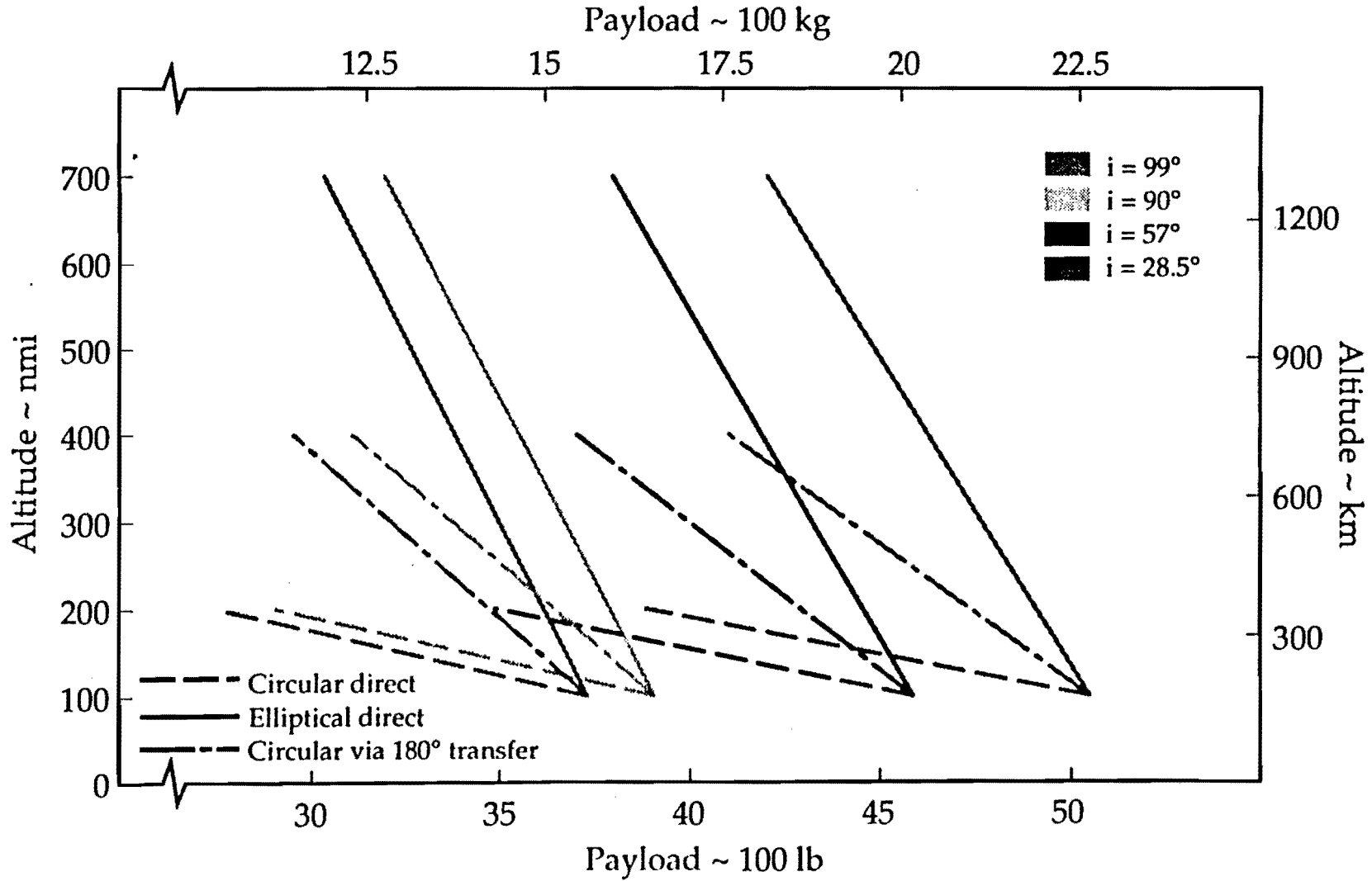



LLV3(6) PERFORMANCE

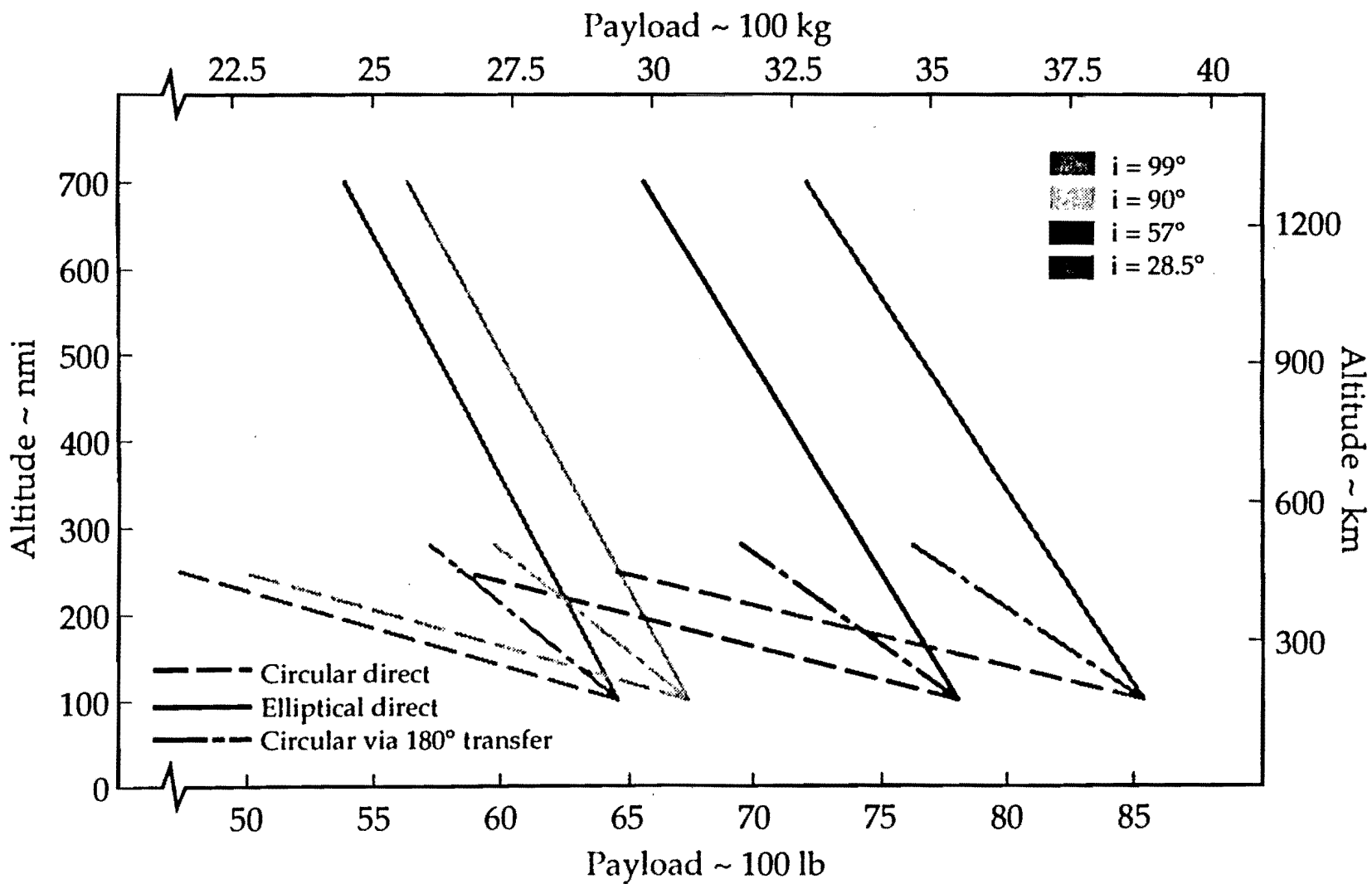

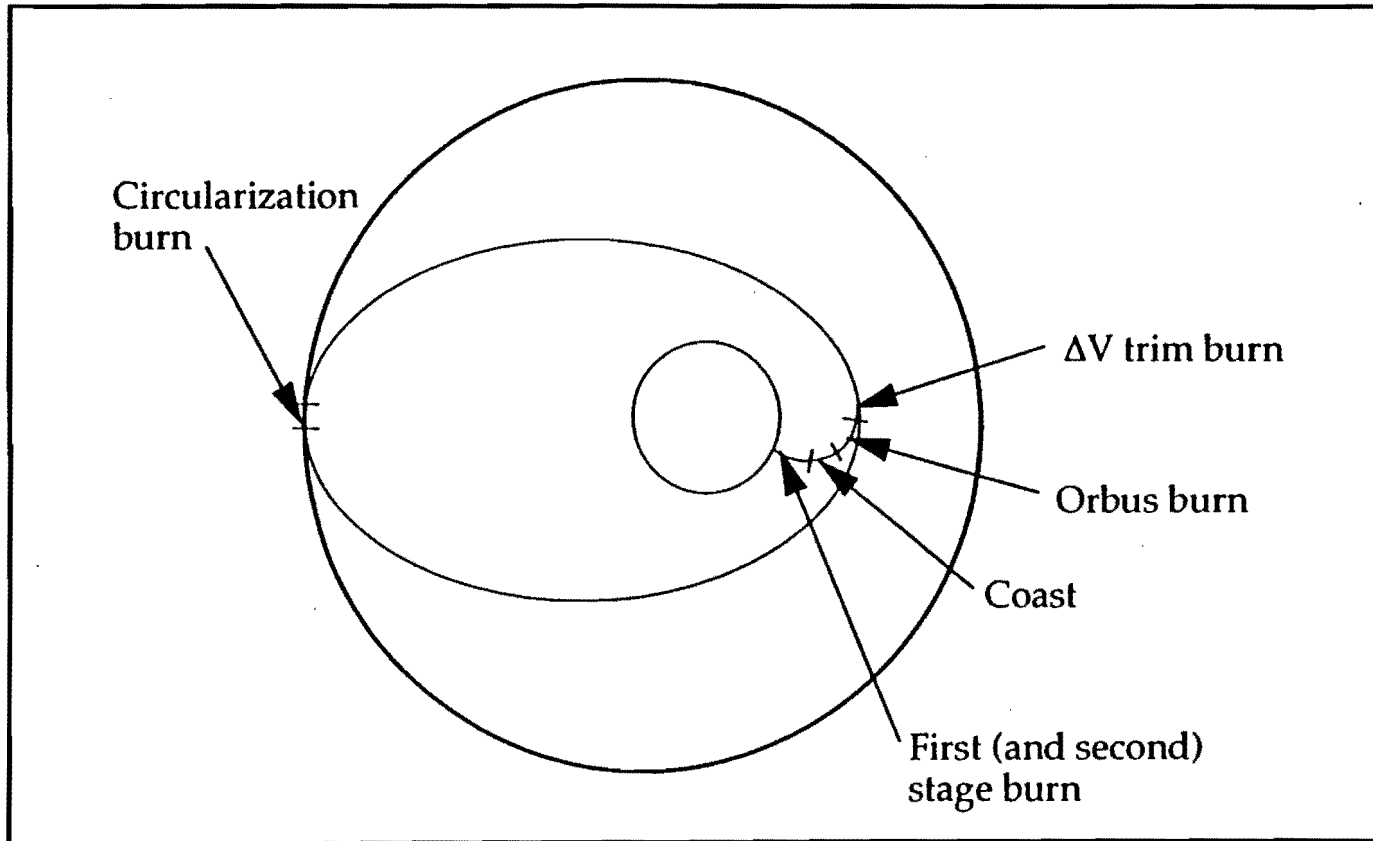



DIRECT INJECTION PROFILE

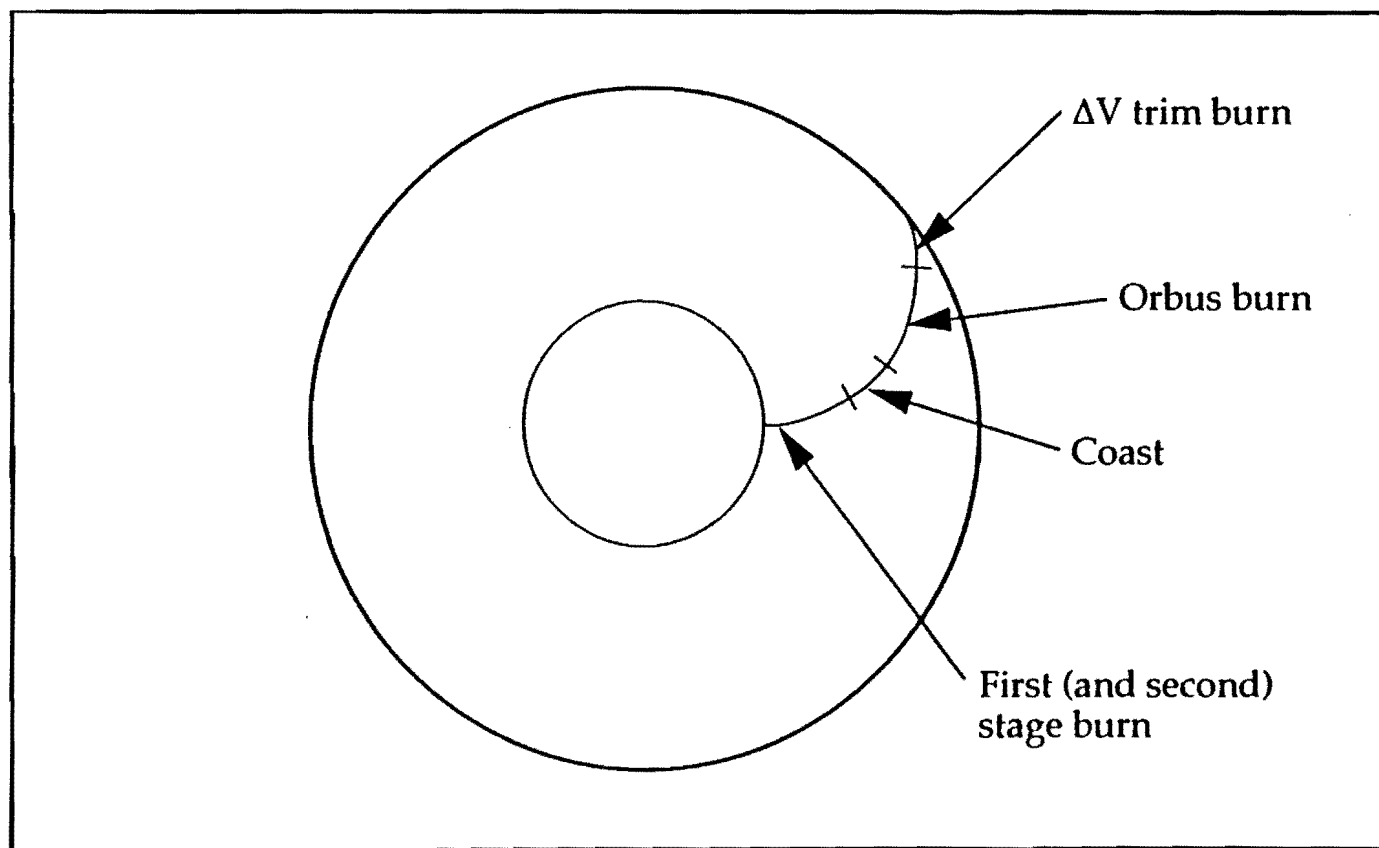

92-in. FAIRING

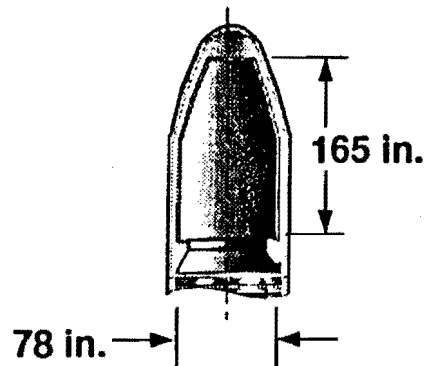

116-in. FAIRING

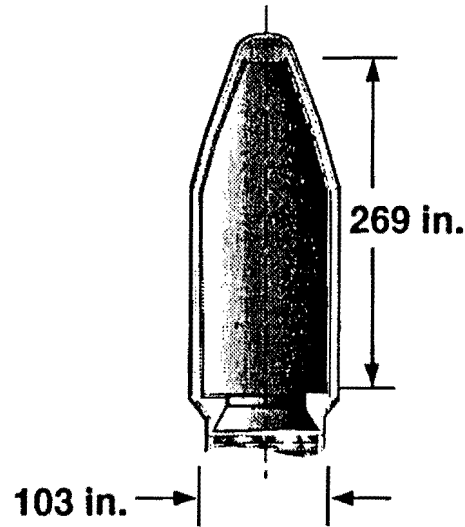

141-in. FAIRING

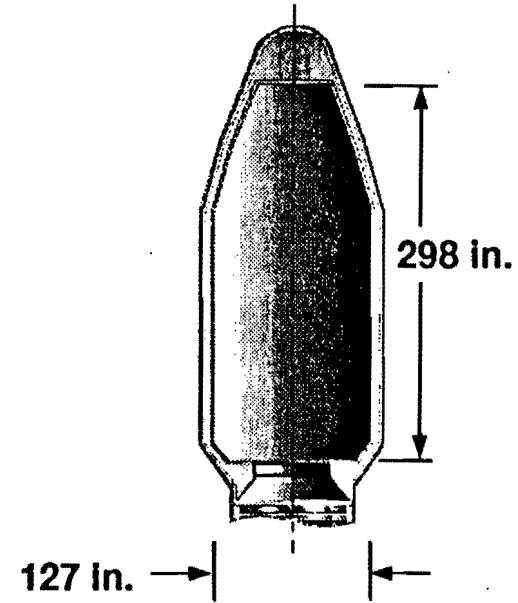



FIXED ADAPTOR SECTION

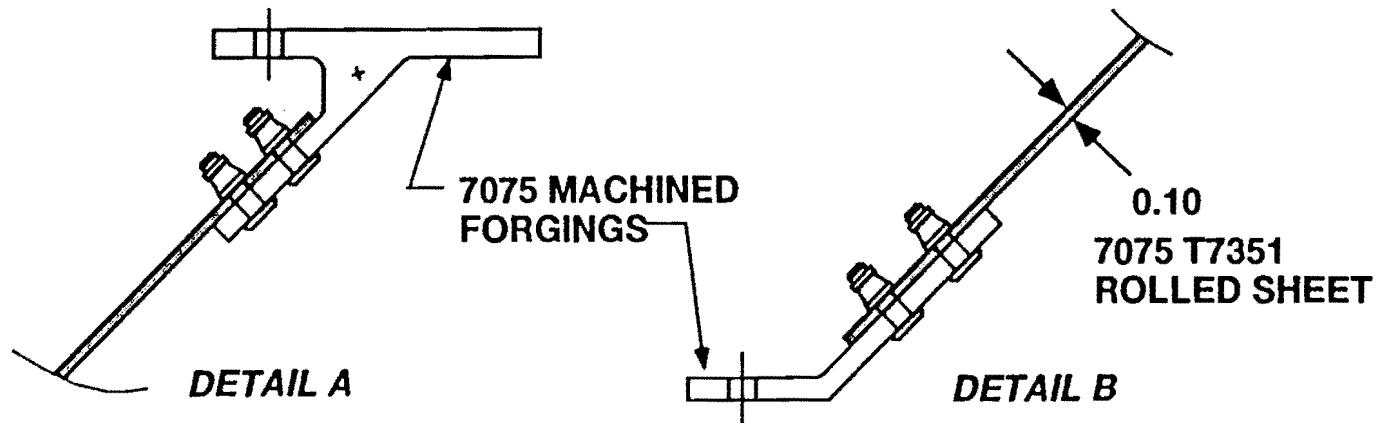
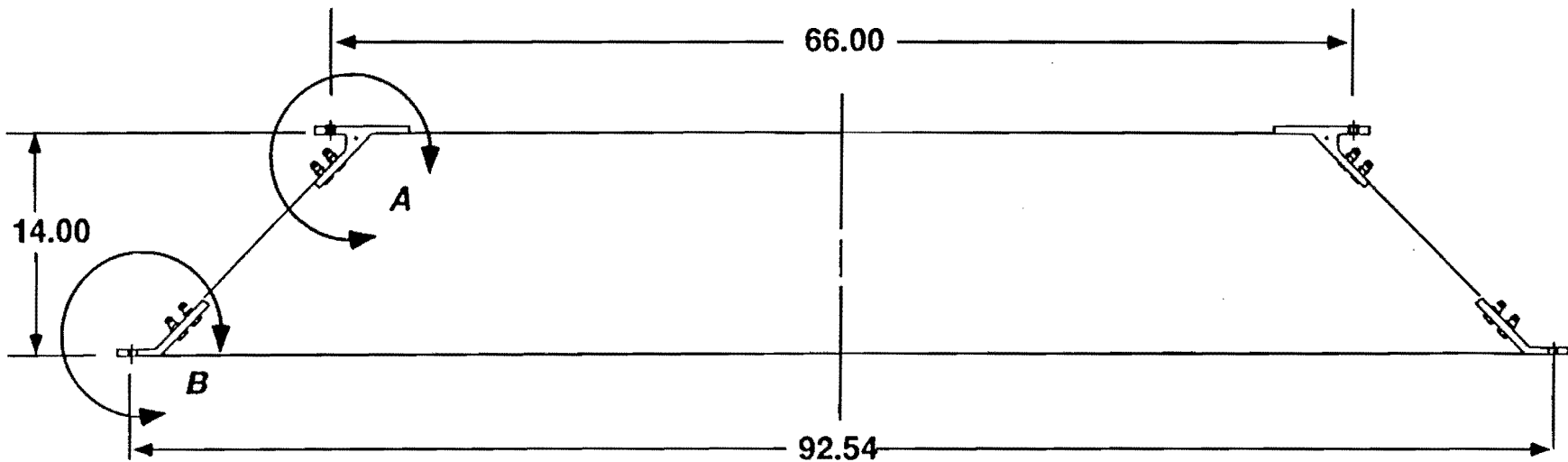



LLV ELECTRICAL INTERFACE



ANALOG TELEMETRY MONITORS (10 PROVIDED)

LAUNCH VEHICLE | SATELLITE

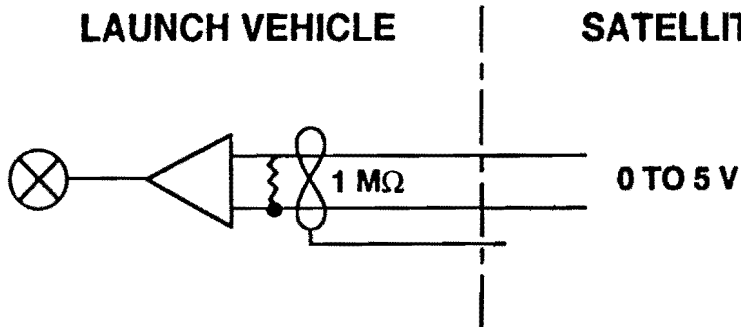

CONTINUITY LOOPS (5 PROVIDED)

LAUNCH VEHICLE | SATELLITE

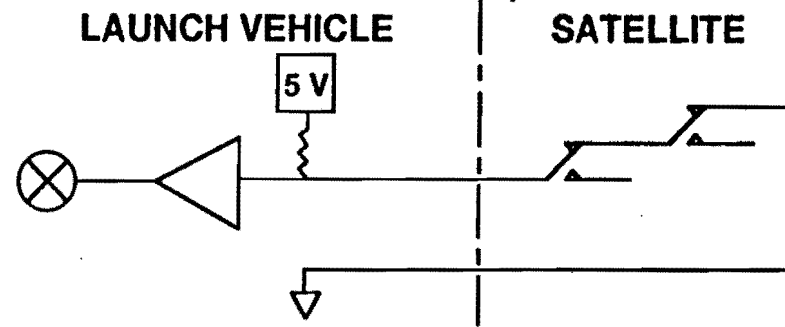

DISCRETE TELEMETRY MONITORS (10 PROVIDED)

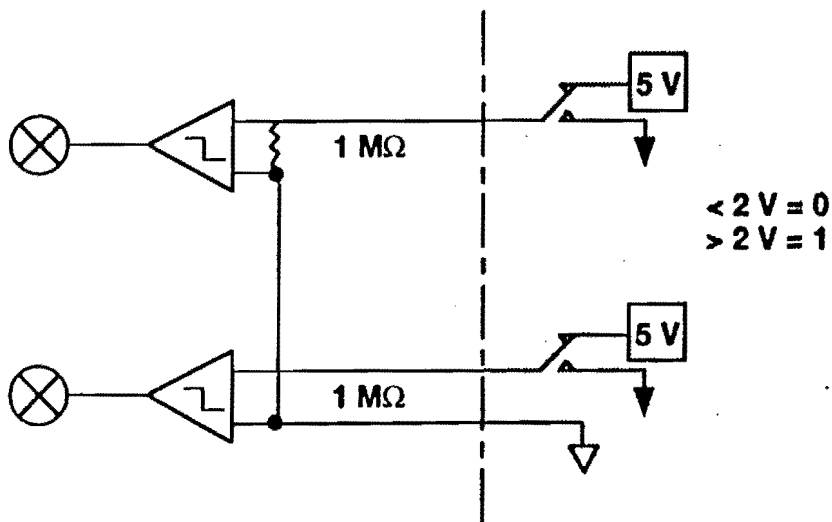

SEPARATION INDICATOR (5 PROVIDED)

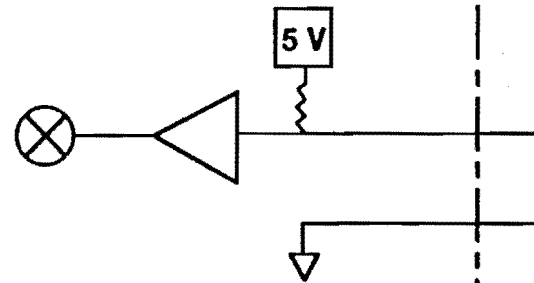

COMMANDS (8 PROVIDED)

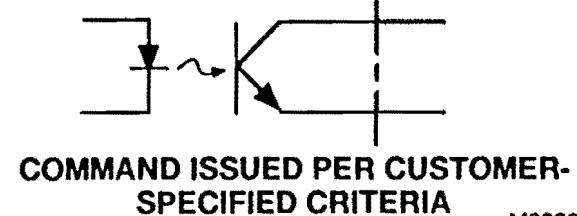



LLV1 LAUNCH ACOUSTIC ENVIRONMENT



PRELIMINARY

OVERALL SOUND PRESSURE: 136.2 dB

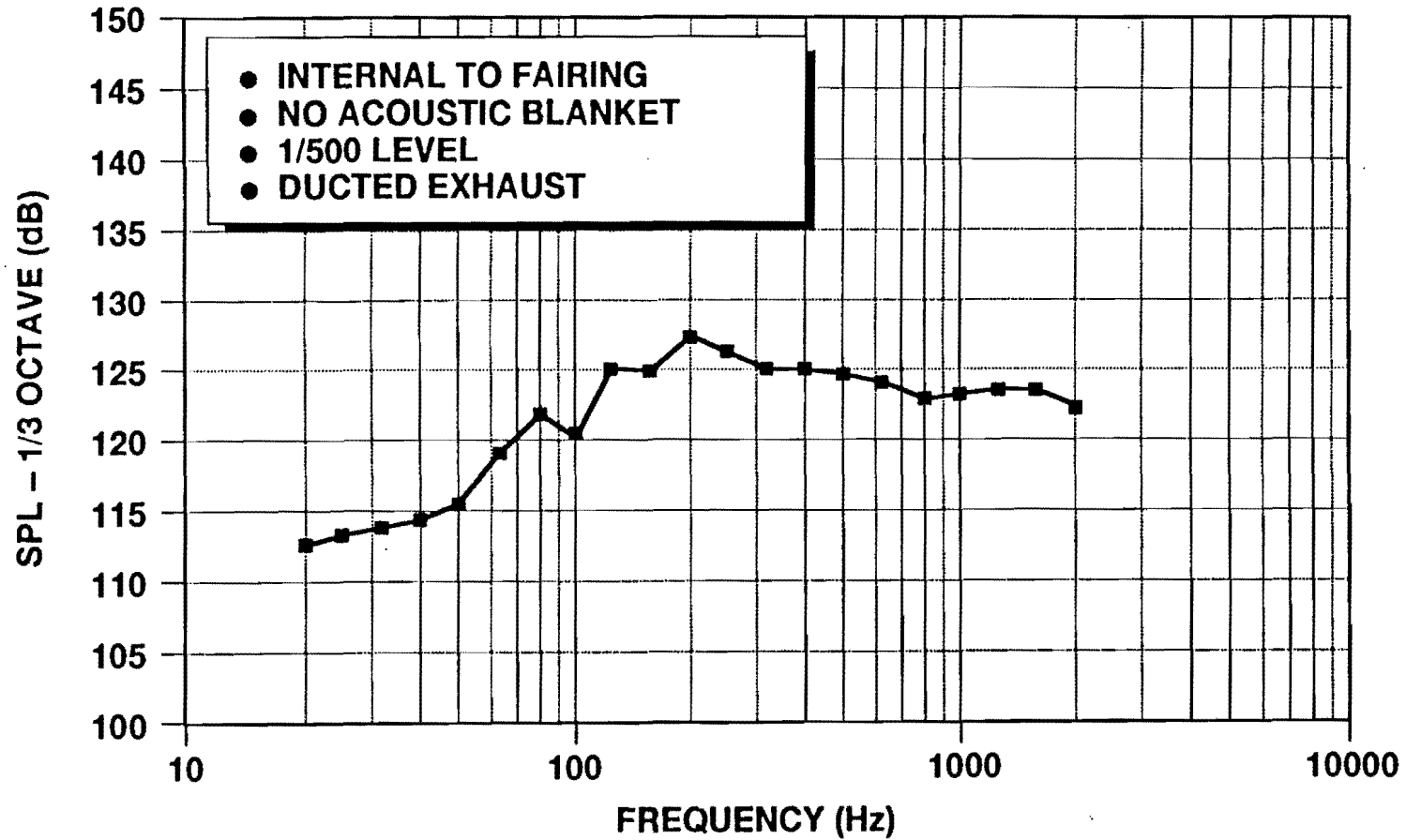



LLV1 RANDOM VIBRATION ENVIRONMENT



PRELIMINARY

OVERALL LEVELS

BOOST PHASE 7.8 g_{rms}

LAUNCH PHASE 3.1 g_{rms}

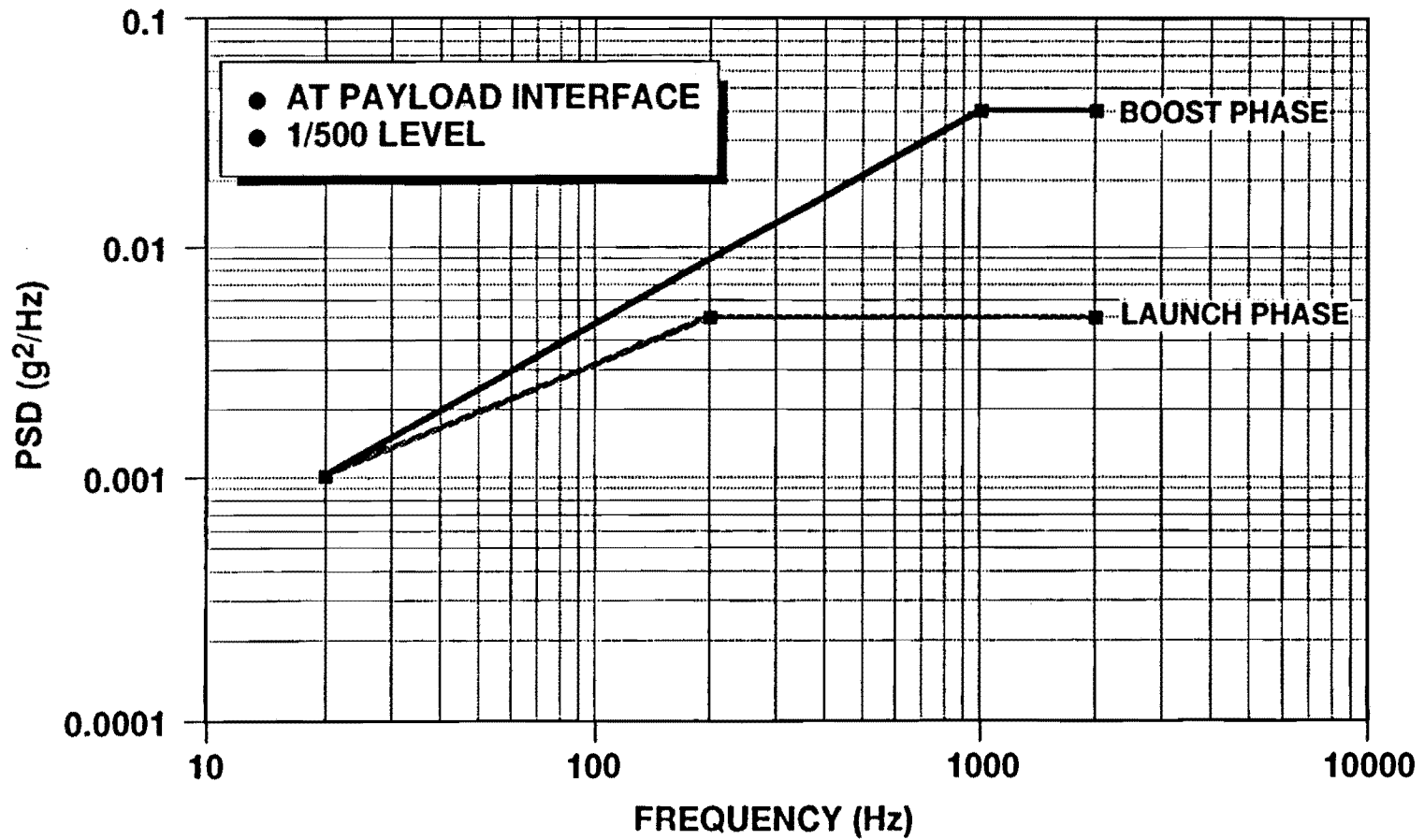



LLV1 SHOCK SPECTRA



PRELIMINARY

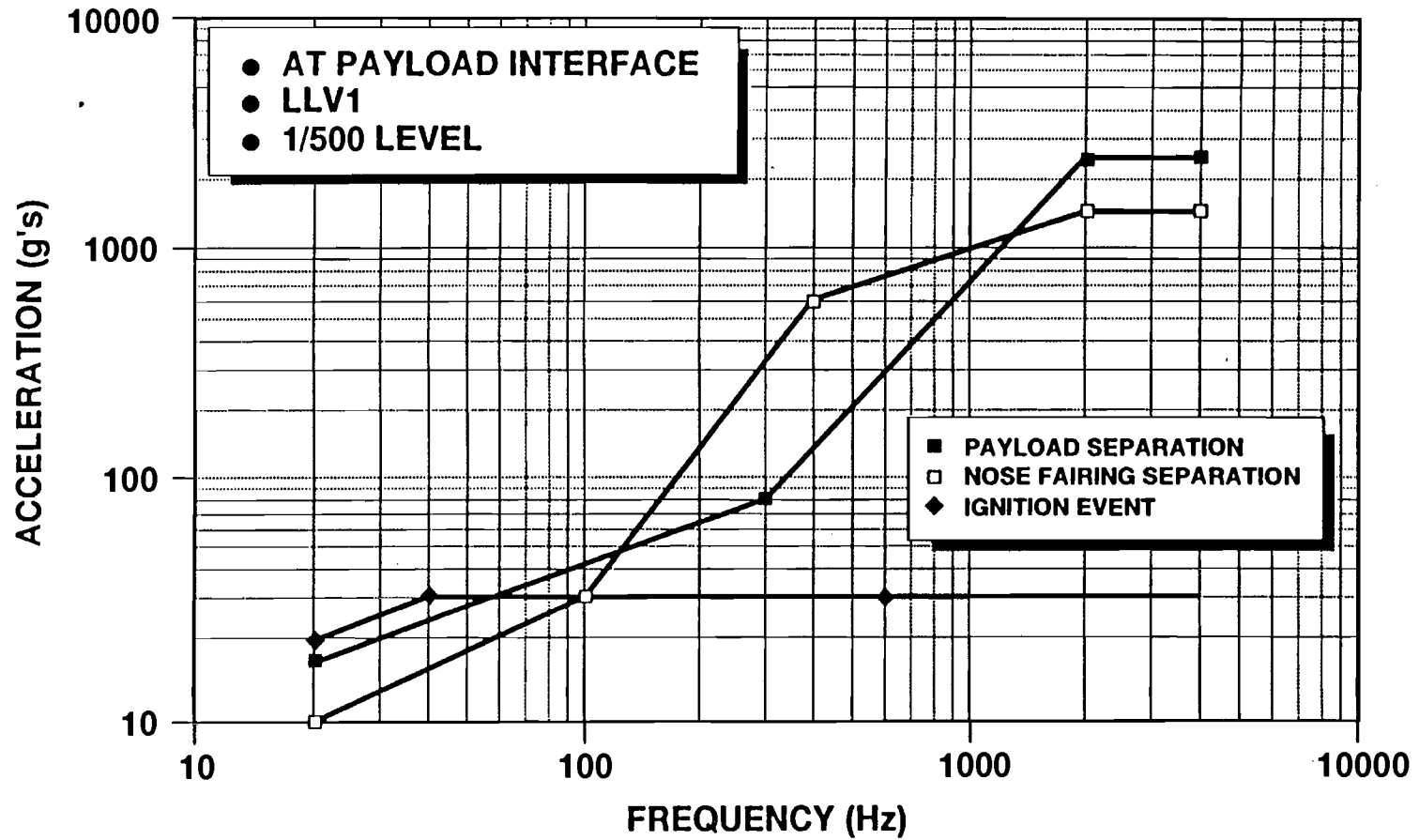



STACK-AND-SHOOT APPROACH

