

Utah State University

DigitalCommons@USU

---

All Graduate Theses and Dissertations

Graduate Studies

---

5-1965

## Determining and Telemetering Snowpack Water Content in Mountainous Terrain

Stephen Davis Clarke

Follow this and additional works at: <https://digitalcommons.usu.edu/etd>

 Part of the [Electrical and Computer Engineering Commons](#)

---

### Recommended Citation

Clarke, Stephen Davis, "Determining and Telemetering Snowpack Water Content in Mountainous Terrain" (1965). *All Graduate Theses and Dissertations*. 1556.

<https://digitalcommons.usu.edu/etd/1556>

This Thesis is brought to you for free and open access by the Graduate Studies at DigitalCommons@USU. It has been accepted for inclusion in All Graduate Theses and Dissertations by an authorized administrator of DigitalCommons@USU. For more information, please contact [digitalcommons@usu.edu](mailto:digitalcommons@usu.edu).



Horizon



DETERMINING AND TELEMETERING SNOWPACK WATER CONTENT  
IN MOUNTAINOUS TERRAIN

by

Stephen Davis Clarke

A thesis submitted in partial fulfillment  
of the requirements for the degree

of

MASTER OF SCIENCE

in

Electrical Engineering

Approved:

\_\_\_\_\_  
Major Professor

\_\_\_\_\_  
~~Head of Department~~

\_\_\_\_\_  
~~Dean of Graduate Studies~~

UTAH STATE UNIVERSITY  
Logan, Utah

1965

Return To  
UTAH WATER RESEARCH LABORATORY  
UTAH STATE UNIVERSITY  
LOGAN, UTAH 84302

Clarke, Stephen D.; 1939; Determining and Telemetering Snowpack Water Content in Mountainous Terrain; Department of Electrical Engineering; Duane G. Chadwick, major professor.

Snowpack water content is an important parameter in streamflow forecasts. At the present time water content of the snowpack is determined by manual methods, which are often expensive and time-consuming. The use of a pressure pillow to determine water content has shown promise in experimental applications.

The design and analysis of a pressure transducer suitable for use with remote telemetry equipment is presented. The transducer uses changing fluid pressure to vary an inductor.

Telemetry techniques suitable for use on Utah snow courses are analyzed. Emphasis is given to the passive and active remote radio relays.

## ACKNOWLEDGMENT

I wish to recognize the willing assistance of Professor Duane G. Chadwick, Associate Professor at Utah State University. The counsel and assistance of Mr. Garry Dinsdale, Assistant Utah State Snow Survey Supervisor, Soil Conservation Service, was appreciated very much also.

Stephen Davis Clarke

## TABLE OF CONTENTS

	Page
INTRODUCTION AND REVIEW OF LITERATURE . . . . .	1
TRANSDUCER DEVELOPMENT AND ANALYSIS . . . . .	4
The pressure pillow . . . . .	4
Transducer methods . . . . .	6
Electronic transducer design . . . . .	7
Methods and procedures . . . . .	14
Analysis of experimental data . . . . .	17
ANALYSIS OF TRANSMISSION TECHNIQUES ON UTAH SNOW COURSES . . . . .	24
The use of wire lines . . . . .	25
The use of radio . . . . .	25
Ground to airplane . . . . .	36
SUMMARY AND CONCLUSIONS . . . . .	38
LITERATURE CITED . . . . .	40

## LIST OF FIGURES

Figure		Page
1	Diagram of pressure pillow method . . . . .	5
2	Variable inductance, pressure transducer . . . . .	8
3	Parts of the pressure transducer . . . . .	9
4	Sample data on spring set . . . . .	11
5	Block diagram of telemetering system . . . . .	13
6	Layout of the Garden City Summit experimental plot . . . . .	15
7	Transducer calibration curve . . . . .	16
8	Comparative water equivalent curves . . . . .	18
9	Electronic equipment error curve . . . . .	19
10	Level fluctuations as a function of temperature . . . . .	22
11	Block diagram of telemetry system using active relay . . . . .	34

## INTRODUCTION AND REVIEW OF LITERATURE

For years one of the important challenges in hydrologic research has been accurate runoff and flood forecasting. The procedure is complicated and has many independent variables. The accuracy of this type of forecasting depends on (a) the assumptions made in predicting the runoff rate of the terrain, and (b) the amount and rate of collection of precipitation.

In the western United States a major problem is prediction of the runoff from snowpack measurement and other measurements. Much hydrologic information has been collected for many geographical areas. As a result, empirical formulas that account for the variables associated with the terrain have been developed. Through the efforts of the United States Soil Conservation Service of the USDA and various cooperating agencies, a great deal of data listing water content of the snowpack have been collected for specific areas (6). Data are collected regularly from snow courses. A typical snow course is a path approximately 500 feet in length. Samples are taken every few feet along the path and averages determined. Each snow course is placed in a location which, in the best judgement of the survey group, gives a representative sample of the area.

In most areas this method of determining the water equivalent of the snowpack is difficult, and expensive in terms of time and money.

For reasons of safety two men are used to survey nearly all snow courses. In many cases over-snow vehicles are used. In extremely remote areas, the high Uinta mountains in Utah, for example, an approximate water equivalent is determined by visually measuring the snow depth using aerial markers, and by estimating the snow density.

The water equivalent of the snowpack is a major parameter in basin runoff forecasts. Therefore, any improvement in the accuracy of measuring the water equivalent should lead to more accurate predictions.

The overall problem approached in this thesis study is that of obtaining more, and more accurate, measurements of total water equivalent, particularly in very inaccessible areas.

Considerable work has been done on this subject to date by other researchers (1, 3, 8, 9). Much of the research has been directed toward developing an accurate transducer to measure the water in the snow. Two of the most promising methods are radio-isotope absorption (3), and the pressure pillow method (1).

During the last few years pioneering work has been done by Chadwick and Pearson (2), and by Warnick, Penton, and Singh (8) in developing telemetering systems to collect hydrologic data from remote areas. Commercial telemetering equipment has been available for some time; but the cost, and in some cases the power requirements, make it unsuitable for economic multiple installations on a watershed.

Advantages of a hydrologic telemetry system are; (a) safety, (b) economy, (c) comfort, (d) time saved, and (e) number of sites



monitored. After a few trips on snowshoes in inclement weather, even the novice snow surveyor can appreciate the value of such a system.

Previous work by Beaumont and Freeman (1) has shown the pressure pillow to be a very promising technique. Additional development was planned in an attempt to develop an economical but accurate system.

The specific purpose of this thesis is to report and evaluate progress in two areas. First, much effort has gone into the design and construction of an improved transducer. Second, the snow courses in the state of Utah have been reviewed and promising telemetry systems have been analyzed.

## TRANSDUCER DEVELOPMENT AND ANALYSIS

### The pressure pillow

The apparatus used in the pressure pillow method is illustrated in Figure 1. The pillow, of butyl rubber reinforced with heavy fabric, is filled with approximately 350 gallons of methyl alcohol. A hose connects the pillow to a standpipe, made from aluminum irrigation pipe open to the air at the top. Alcohol from the pillow rises in the standpipe as weight is placed on top of the pillow. The height of the alcohol in the standpipe is  $h_0$  with no water on the pillow. As water is added, the pressure at the top of the pillow increases. This increase is balanced exactly by the increase of pressure in the standpipe at level,  $h_0$ . The amount of water on the pillow, therefore, can be measured by measuring the pressure in the standpipe at level,  $h_0$ .

The standpipe has a known, constant cross-sectional area,  $A_1$ , and the density,  $d(t)$ , of the fluid is a known function of temperature. The assumption is made that for all practical purposes the density of the alcohol equals its specific gravity. The difference,  $\Delta h$ , is the height of the fluid in the standpipe with water on the pillow, minus the height of the fluid with no water on the pillow. The pressure in the standpipe at level  $h_0$  is given by

$$P_{ho} = \frac{d(t) \Delta h A_1}{A_1} = d(t) \Delta h$$

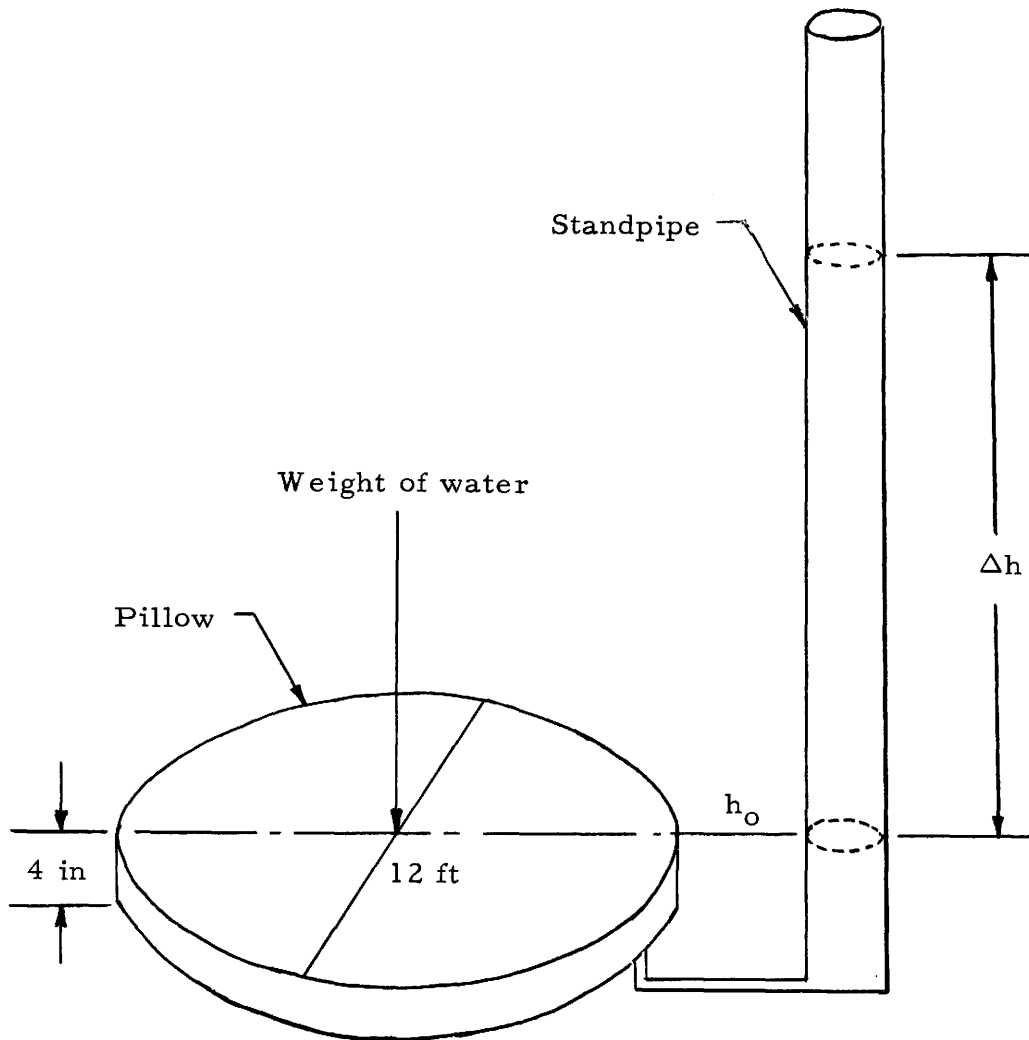

Figure 1. Diagram of pressure pillow method

The pressure at the top of the pillow, or level  $h_0$  is

$$P_{ho} = \frac{\text{weight of water}}{\text{area of pillow}}$$

and since these two pressures must be equal,

$$\Delta h = \frac{(\text{weight of water})}{(\text{area of pillow})} \frac{1}{d(t)}$$

in which  $d(t)$  and the area of the pillow are known.

Therefore,  $\Delta h$  is directly proportional to the amount of water resting on the pillow, and the problem resolves itself to measuring  $\Delta h$ .

### Transducer methods

The use of a clear manometer tube in which  $\Delta h$  can be read directly is the obvious method, but does not lend itself to an electrical readout system. Another method of measuring  $\Delta h$  is the use of a commercially available fluid level recorder. Such an instrument is the Leupold-Stevens Type F Model 61, which makes a continuous pen recording of fluid level over a period of a week. This type of instrument is now being used in some experimental areas. Commercial pressure-to-electric signal transducers were available, but the \$400 price tag seemed excessive.

Another idea, conceived by Professor Chadwick, involves using the changing fluid level to vary an inductance. An inductance change can

be easily adapted to electronic measurement. This ingenious method is the basis of the pressure transducer that has been adopted.

### Electronic transducer design

The most satisfactory electronic transducer system is illustrated in Figure 2. The pipe is a three-inch aluminum irrigation pipe containing a float made of one-half-inch, thin walled, steel, electrical conduit. The coil is wound on a nylon form and the spring is of custom design. The "E"-shaped rider consists of a brass carrier with inserts of commercial core material, as shown in Figures 3a and 3b. The coil form detail is shown in Figure 3c. A small metallic friction detector located in the bottom of the coil form is useful for obtaining accurate data. By measuring the resistance between the detector and the center rod one may easily determine the presence of friction.

The coil inductance is varied by movement of the core material in the vicinity of the coil. The position of the core material is determined by a combination of the hydrostatic fluid pressure and the spring force.

The transducer is designed to measure a predetermined maximum number of inches of water on the pillow. As an example, suppose 100 inches of water was the maximum accumulation expected. The fluid level in the standpipe would change a maximum of 100 inches divided by the density of the fluid. For alcohol the change in fluid level would be approximately 125 inches by the time there were 100 inches of water on the pillow. If the top of the float actually floated in the alcohol, it

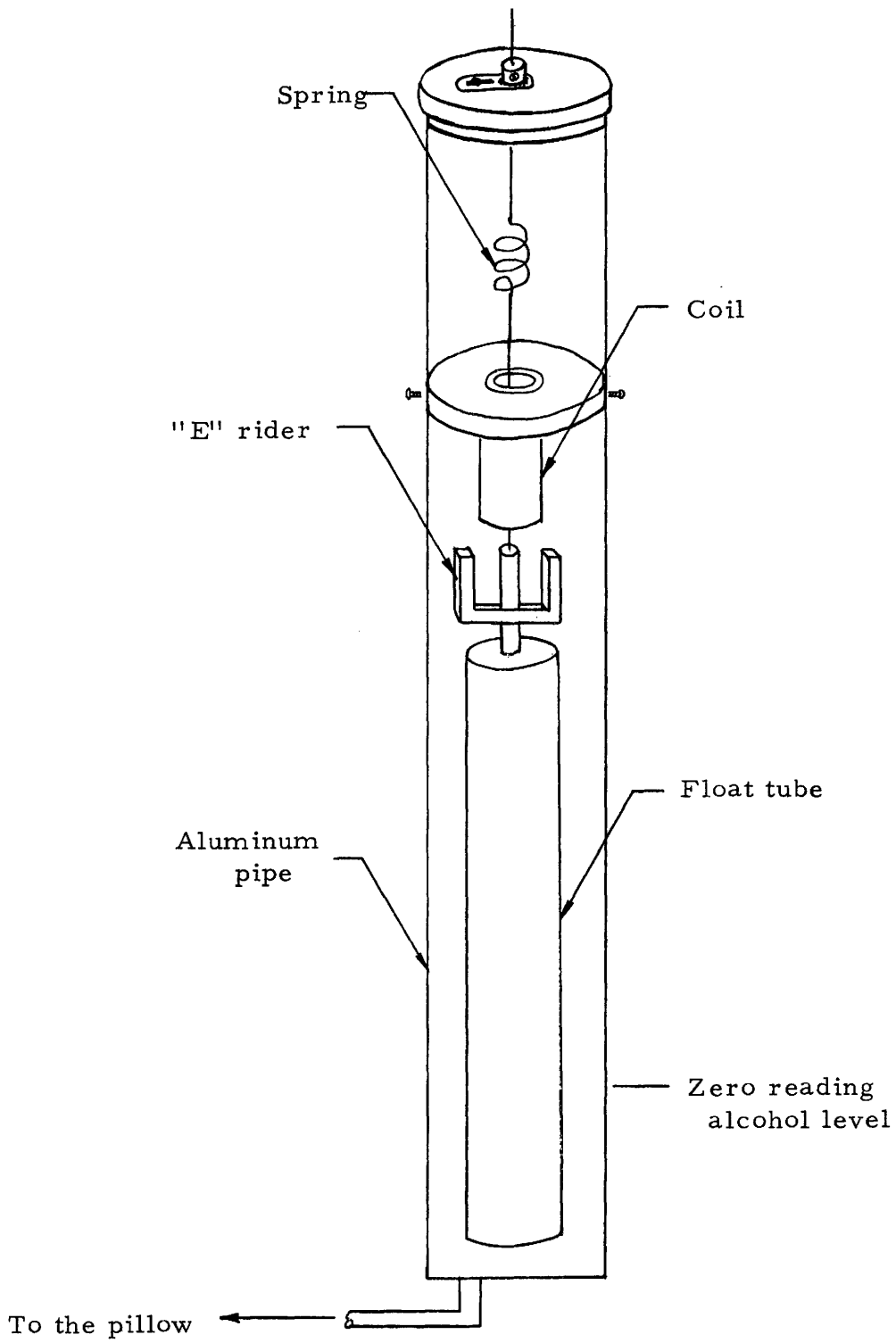

Figure 2. Variable inductance, pressure transducer

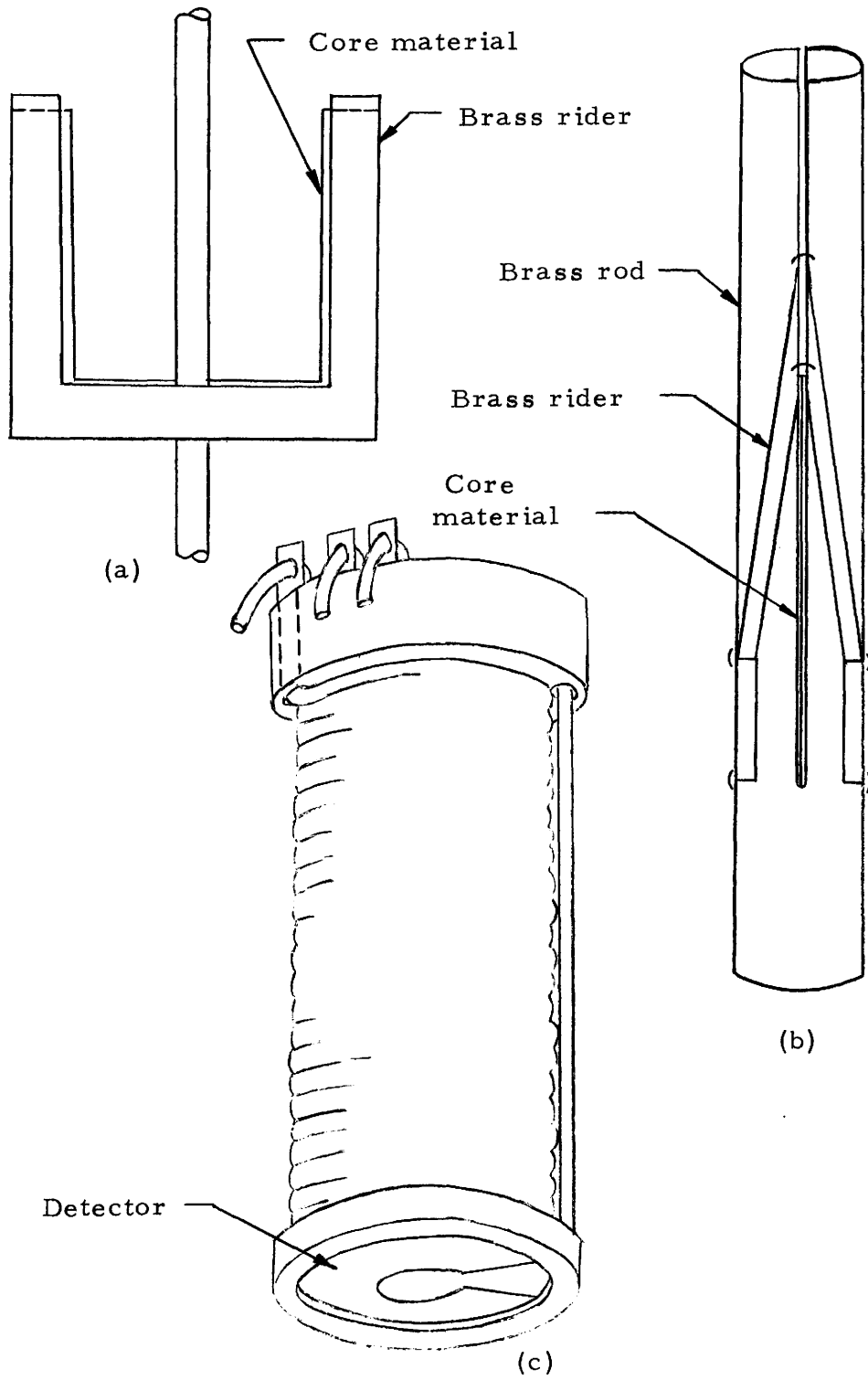

Figure 3. Parts of the pressure transducer

would move a maximum of 125 inches. Construction of a coil compatible electrically with the rest of the system required that the movement of the core material be limited to approximately 1.5 inches total. Therefore, the float was made heavy so that when the fluid level raised 125 inches the spring caused the float to rise 1.5 inches. This system will henceforth be referred to as the 100-inch system. A system designed to measure 50 inches of water will be referred to as a 50-inch system. Obviously a transducer could be designed to give 1.5 inches of float movement, corresponding to any maximum capacity greater than 1.5 inches of water.

In a system designed to measure 50 inches of water, an addition of 0.1 inch of water would move the rider  $(0.1)(1.5)/(50) = 0.003$  inch. Fortunately, this amount of movement gives an easily measurable inductance change. The value of the friction detector is emphasized by the very small physical movements involved.

The spring was the most challenging item in the transducer design. A spring stressed continuously for a period of months develops a set, which increases with stress and temperature. The set also is a function of the type of material used in making the spring. Extensive testing showed the spring creep to be a long term phenomenon. Figure 4 presents some typical data for a spring of 0.063-inch-diameter music wire steel stressed at 29,000 pounds per square inch. The rated stress capacity of this spring steel is 100,000 pounds per square inch.



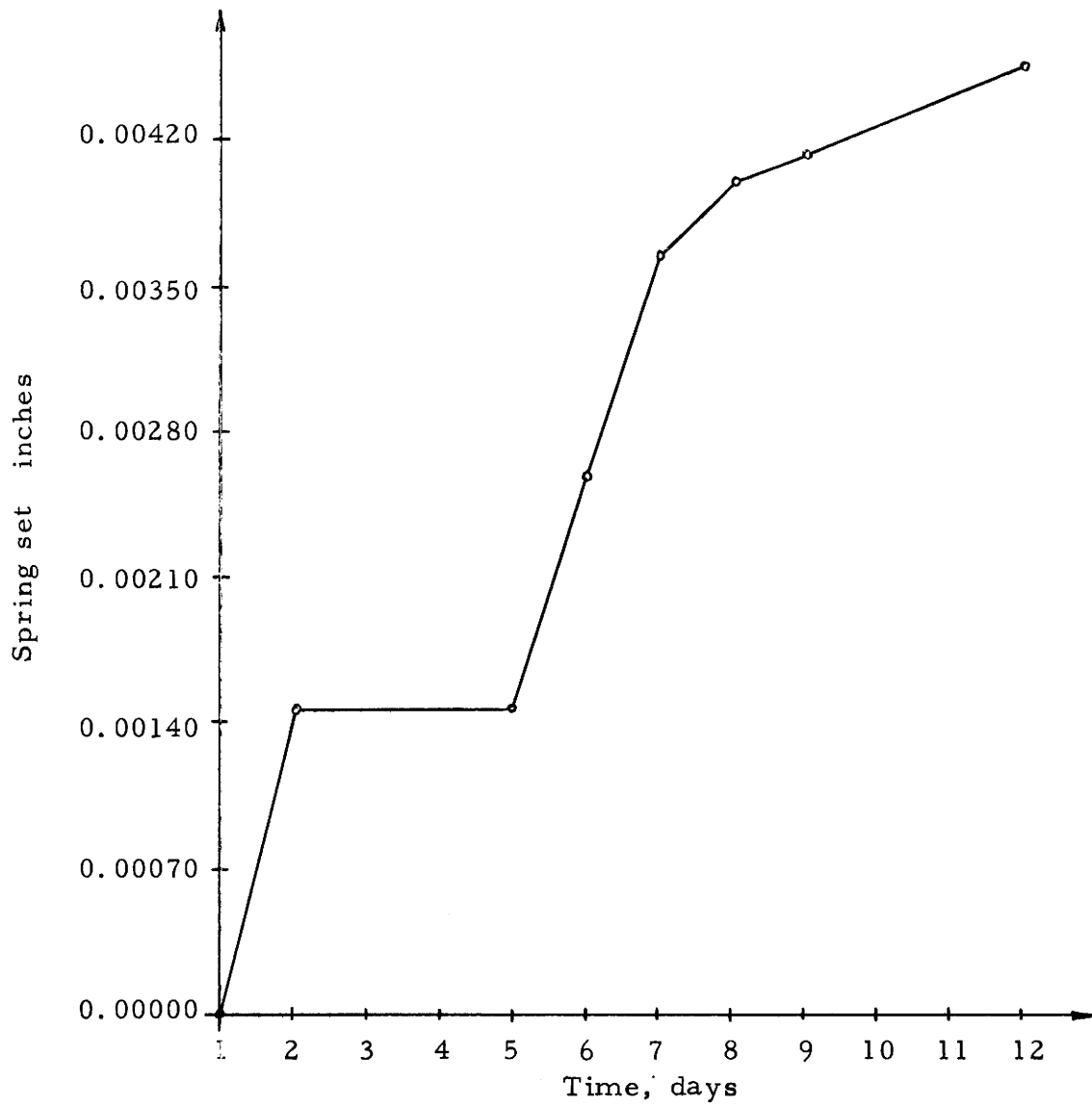

Figure 4. Sample data on spring set

Figure 4 shows that spring set is a function of time. The vertical scale represents the spring set and the variation of 0.0045 inch represents 0.30 inch of water in a 100-inch system. Such an error was judged unacceptable.

Further research in spring design led to the conclusion that suitable springs could be constructed. Wahl (7) presents excellent material in this area. The Associated Spring Company was contacted, and they agreed to construct a spring suitable for the 100-inch system. This spring is now in operation on Mount Hood in the state of Oregon and is working well. By using better steel and stress-relieving techniques, a spring was constructed for the smaller 50-inch system, which was acceptable. When 0.045-inch-diameter high grade music wire was used and the newly formed spring was heat treated at 500 F for one-half hour, the set was not measurable after one day. With the mechanical design now complete, the transducer was ready for integration with the electronic telemetering equipment.

Research was being conducted concurrently on the development of the transducer and the telemetering equipment to be used. Those conducting this research and development were Professors Duane G. Chadwick, Dale Dunmire, Pat Buller, and Don Griffin, all of Utah State University. Since the equipment developed by this group will be used throughout the remainder of the thesis project, a block diagram of the system is presented in Figure 5.

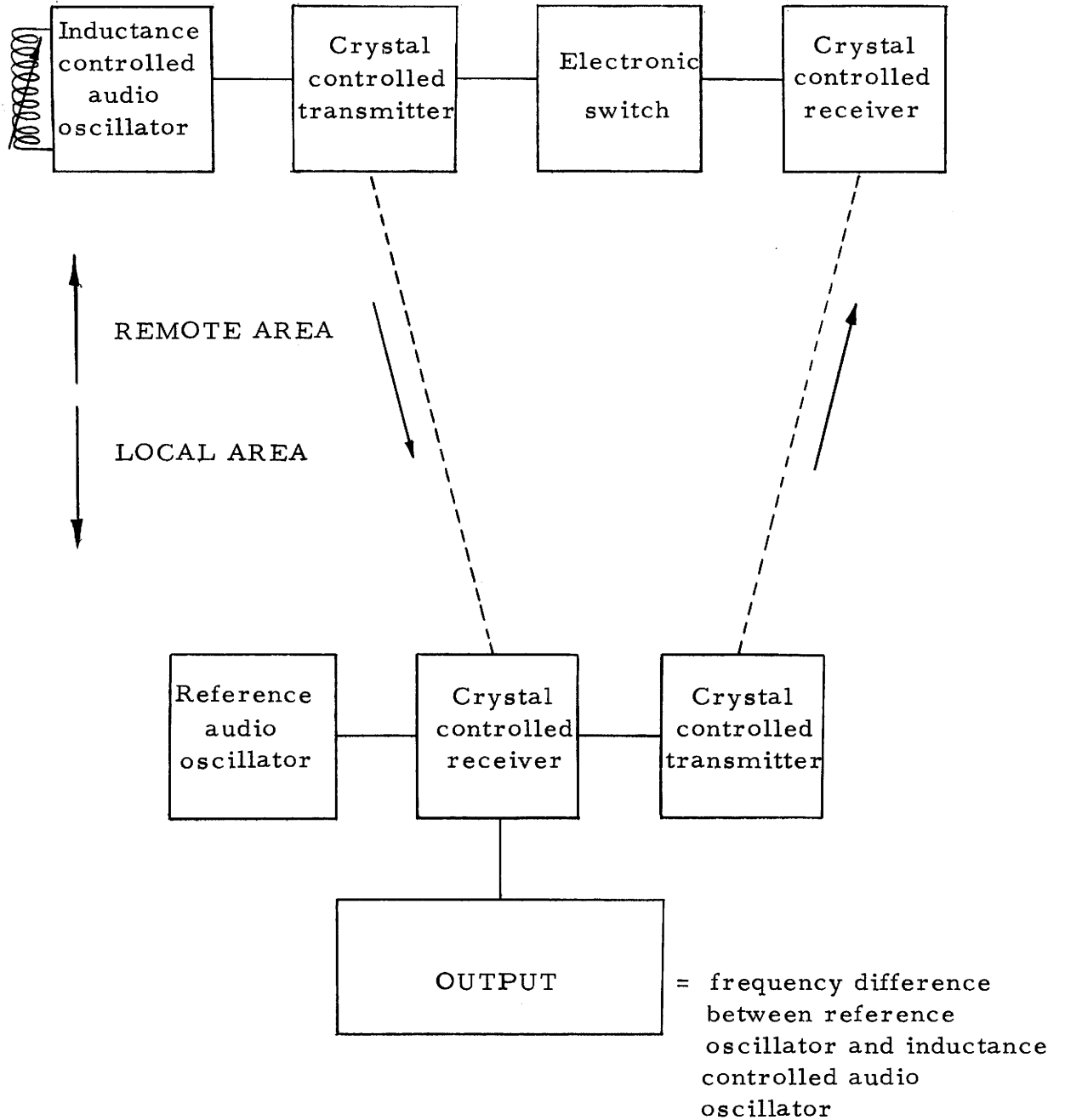

Figure 5. Block diagram of telemetering system

The system works on an on-call basis. The operator can interrogate the remote station and receive the data in the form of a calibrated dial reading. The inductance-controlled audio oscillator provides modulation frequencies from 1,000 cycles per second to 3,500 cycles per second. The carrier frequency is 32.635 megacycles per second.

The 50-inch system was installed, calibrated, and connected to the 12-foot-diameter pillow at the Garden City Summit experimental plot on November 18, 1964.

A sketch of the Garden City Summit experimental plot is presented in Figure 6. The pillows are placed on a leveled bed of sawdust enclosed by a four-foot fence. The instrument house contains the transducer and two "F-type" recorders. Figure 7 gives the calibration curve of the unit. Calibration is accomplished by disconnecting the standpipe from the pillow and connecting it to a clear manometer tube. Then, as the fluid level is changed, visual and instrument readings can be obtained. It is worthy of note that in general the curve is smooth and uniform and is exactly reproducible for this type of system. Any mechanical friction in the system gives irregular, nonuniform portions of the curve.

#### Methods and procedures

Once each week, throughout the winter and spring months, a trip was made to the experimental site. The temperature in the instrument house and the total precipitation were recorded. Using the conventional Federal snow sampling tube samples were obtained in the plot located

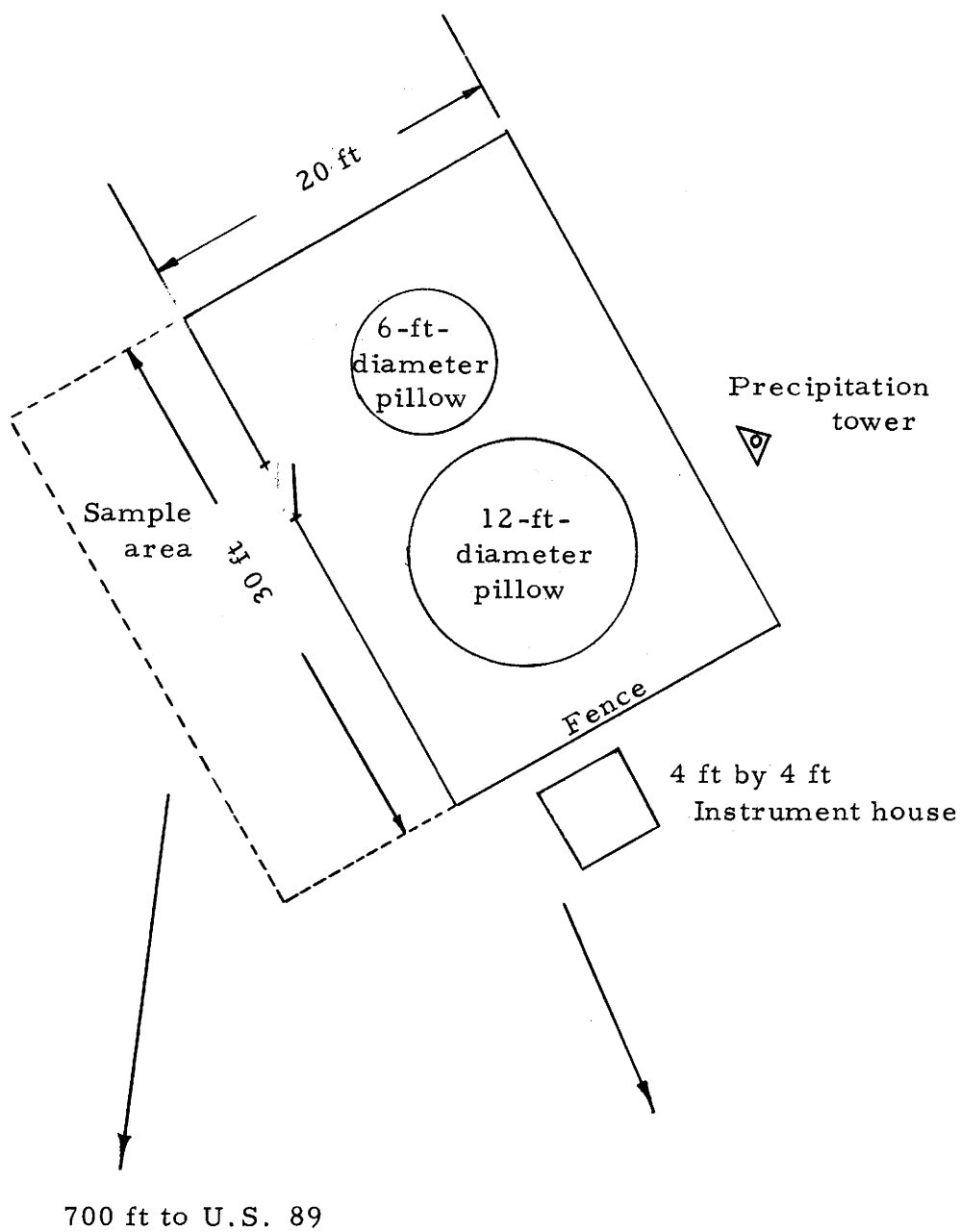

Figure 6. Layout of the Garden City Summit experimental plot

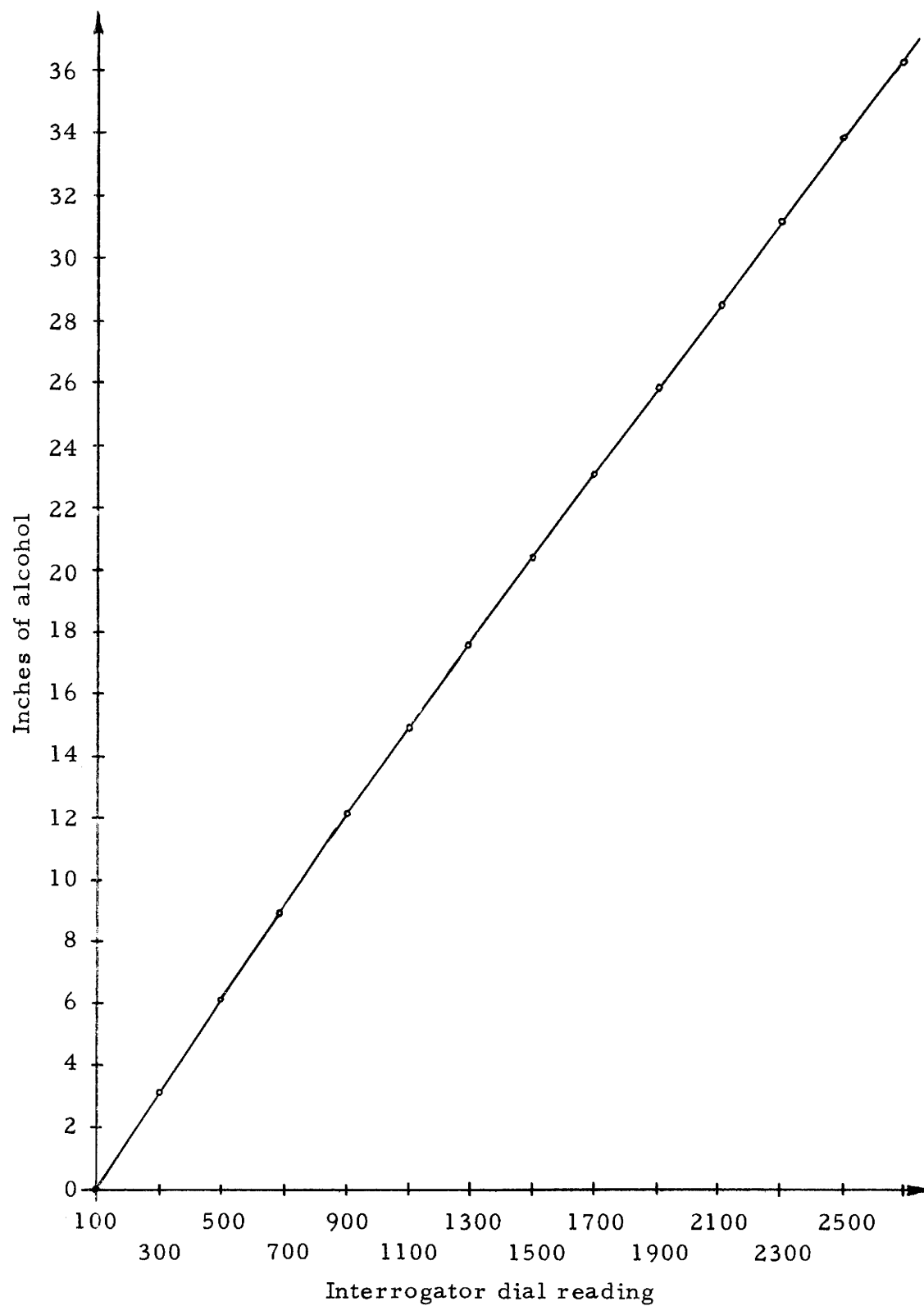

Figure 7. Transducer calibration curve

just west of the fence containing the pillows. The Leupold-Stevens F-type recorders were read and the charts were changed. The electronic gear was interrogated from the road at the beginning and end of each survey.

The data obtained are summarized in Figure 8. Figure 8 shows the correlation between the F-type recorder, the electronic gear, the snow tube sample, and the rain gage. The F-type level recorder is assumed to be accurate and is used as the standard throughout the present study. The electronic transducer error is shown in Figure 9.

#### Analysis of experimental data

In analyzing Figure 8 the feature of most interest is the very close correlation between the F-type recorder and the electronic gear. The maximum difference is 0.32 inch and the average difference is only 0.09 inch of water. If the four worst readings were not included the average difference would be 0.05 inch of water.

Several possible sources of the error in these readings exist. Human error in reading the F-type recorder and the electronic interrogator is probable and the manual calibration of the electronic gear makes error possible in reading both the manometer tube and the interrogator unit. The F-type recorder contains a steel tape supported by a pulley. One end of the tape is attached to a float and the other to a lead counterweight. Measurements show that with an increase of 30 inches in the alcohol column the recorder will read 0.09 inch too much alcohol

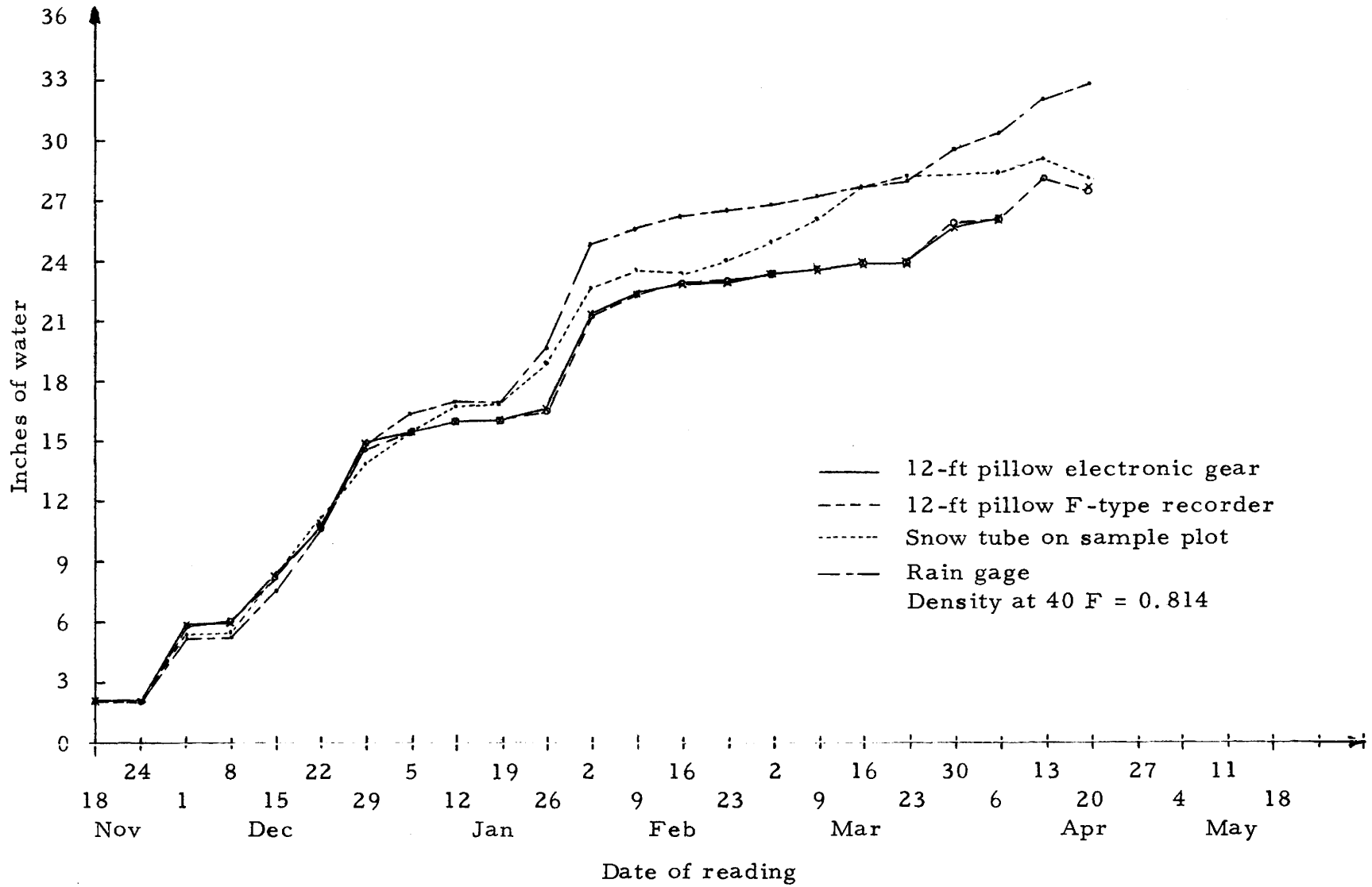

Figure 8. Comparative water equivalent curves



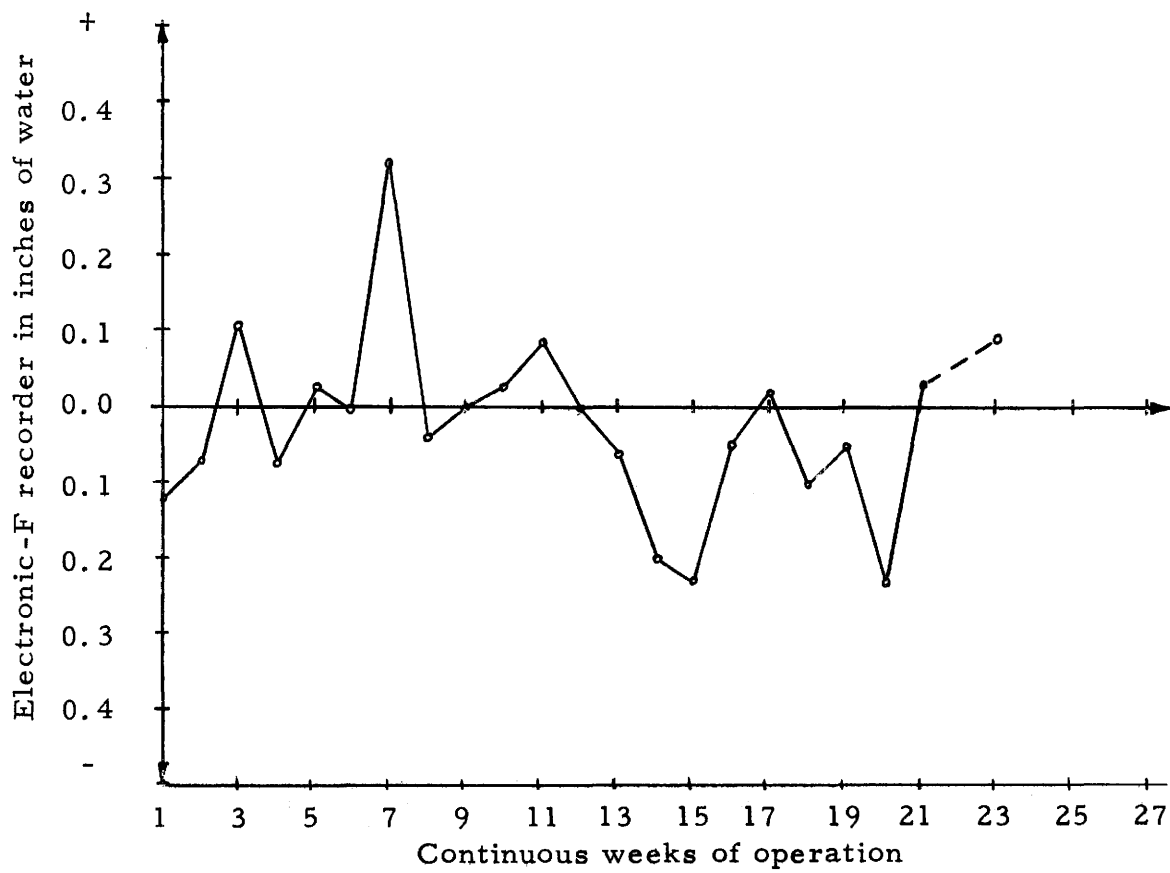

Figure 9. Electronic equipment error curve

because of the shift in weight of the steel tape. It is interesting to note that in the spring of the year the F-type recorder consistently tended to measure higher than the electronic gear.

Between November 18, 1964, and March 30, 1965, temperature in the instrument house at the time the readings were made varied from a low of 20 F to a high of 47 F, a difference of only 27 degrees. The reactions of the spring and the long aluminum pipe to the temperature changes tend to cancel each other. But the temperature effect on the alcohol column appears directly in the readings. This effect is treated separately in the analysis of data.

Further analysis of Figure 8 shows excellent correlation between the rain gage and the pillow, with the exception of the weeks of December 29 to January 5, and January 19 to January 26. Heavy rain was recorded during both of these weeks. Pearson (5) has reported that when mid-winter rains occur the rain gage catches more water than the snow pack retains. When this correction is made, the rain gage curve and the pillow curve come in close correspondence. This fact and the work of Beaumont and Freeman (1) discredit any claim that significant bridging of snow on the pillow occurs.

The Federal snow sample tube is known to measure as much as ten percent too much, depending on the snow density (9). The location of the sample plot also explains the snow tube curve shape. The sample plot shown in Figure 6 lies at the bottom of a slope rising to the west and

south in an area that receives less sunshine than the pillows. To some extent drifting of the snow occurs because of the proximity of the fence to the sample plot. All of these factors tend to make the snow tube curve inaccurate.

Figure 10 illustrates an interesting phenomenon. When the valve to the six-foot pillow was closed so that the standpipe was isolated from the pillow, the daily level fluctuations were as shown. Exactly the same type of fluctuation was present during days when no new precipitation was recorded and the standpipe was connected to the pillow. When snow was packed around the standpipe, the fluctuations were very much reduced until meltback around the aluminum pipe reached one inch. All of these results point to a temperature effect. In fact, the height of the alcohol column at a cold temperature is related to the height of the column when the temperature is warm by the ratio of the densities of the fluid. Specifically, if  $t_2 > t_1$

$$h_{t_1} = h_{t_2} \frac{d(t_2)}{d(t_1)}$$

If the temperature of the alcohol column changed only  $10^{\circ}$  F from 5:00 p.m. on April 7, 1965, to 8:00 a.m. on April 8, 1965, the density change of the alcohol accounts entirely for the noted variations. The significance of the density effects is that the accuracy of the electronic gear and the F-type recorder depends on the temperature.

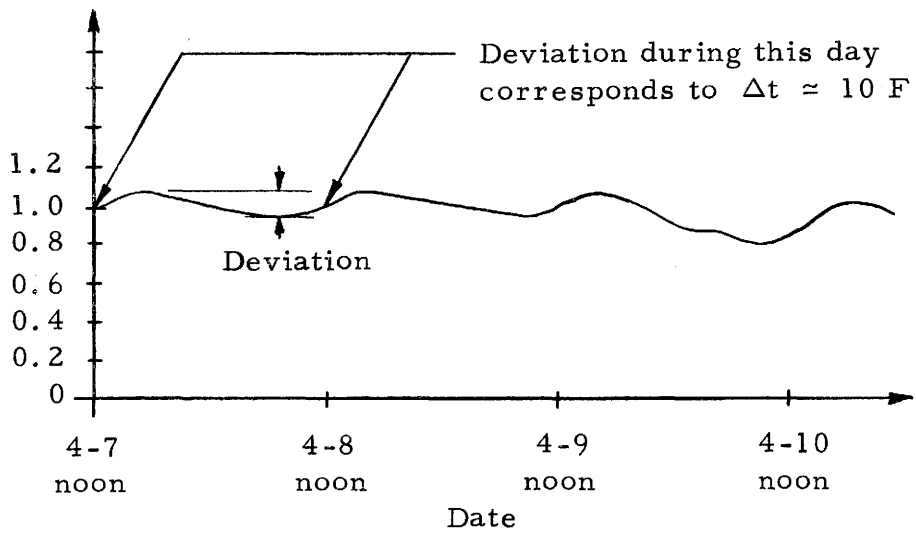

Figure 10. Level fluctuations as a function of temperature

Daily barometric pressure fluctuations follow much the same pattern shown in Figure 10. This effect has been assumed equal to zero in the present analysis because the system is open to the atmosphere on both ends. If the snowpack is considered porous the effect is zero, and, if the snowpack is impervious to air, the work of Beaumont and Freeman (1) demonstrating that bridging effects are negligible validates the assumption.

ANALYSIS OF TRANSMISSION TECHNIQUES  
ON UTAH SNOW COURSES

In snow covered mountain areas, the 32 megacycle carrier frequency practically limits transmission to a line-of-sight path. This limitation is undesirable for mountainous area telemetry but was the result of the frequency allocation by the Federal Communications Commission. With the help of Mr. Garry Dinsdale, Assistant Snow Survey Supervisor, Salt Lake City, Utah, a comprehensive survey of the Utah snow courses was made. The purpose of this survey was to determine the transmission requirements of each snow sampling site. One of the requirements for a snow survey site is an undisturbed snowpack. For this reason, sites have been purposely located on the valley floors and in otherwise sheltered areas.

The results of the transmission requirement survey are summarized as follows. There are 174 listed snow survey sites in Utah, of which approximately 150 are now being used. The survey covered 111 of the sites. Of these only 15 could be interrogated directly from roads that remain open through the winter. Because so many of the available snow courses cannot be interrogated from open roads, a telemetry system must be developed.

### The use of wire lines

A possible solution would be to locate the telemetry receiver and transmitter on a hill or other vantage point and then run a wire from the survey site to the telemetry equipment. By locating the audio oscillator with the transducer, this method could be used. The transmission requirement survey indicated that in most cases the telemetry equipment should be 1,000 to 3,000 feet from the survey site. With the advantage of a better site for the telemetry equipment, approximately 20 additional stations could be interrogated from the road. The costs of installing a pole line and then maintaining that line were judged to be undesirable. As a result this method has not been developed further.

### The use of radio

Ground-to-ground transmission is desirable because of its simplicity. The ultimate goal of a precipitation telemetry system is interrogation of all the survey sites in the state from a single location. The limiting factor in such a scheme is the tremendous power level necessary. To maintain enough battery power at 150 remote stations to transmit long distances where there is not a line-of-sight path is not practical.

Current research is being done by Mr. Pat Buller of Utah State University on transmission using meteor trails to bounce the information back to a recovery site. The method holds some promise.

Another method is the use of a passive relay station. Such a station would consist of back-to-back antennas located on a mountain top or ridge. One antenna would have a line-of-sight path to the remote survey site and the other antenna would have a line-of-sight path to the location of the interrogator. The transmission requirement survey indicates that at least 14 additional survey sites may be reached using this method.

One possible type of antenna for this application is the rhombic antenna. Calculations show undesirable problems are associated with the rhombic antenna. The gain of the antenna increases as the lengths of the sides are made several wavelengths long, but as the gain increases the positive vertical angle of radiation also increases. Generally the nature of the relay location is such that a negative angle of radiation is needed for a line-of-sight path to the remote survey site. This fact, and the realization that the side lengths will approach 60 to 200 feet for high gains make the rhombic antenna unattractive in this application.

Another high gain, directive antenna worthy of investigation is the Yagi type. The Yagi antenna can be polarized either horizontally or vertically, whereas the main disadvantage of the rhombic antenna is its horizontal polarization. Vertical polarization allows the direction of maximum radiation to become coincident with the line-of-sight paths to the remote survey site and the interrogating unit. Orr (4) showed that at 30 megacycles, the four element array, with element



spacings of approximately 0.18 wavelength and a boom length of 0.54 wavelength, gives 13.2 decibels of power gain over an isotropic radiator. Actual measured gains vary greatly from this figure with usual gains of 7.5 to 10.0 decibels.

Since both the interrogation and remote survey site electronic equipment have comparable receivers and transmitters, the problem will be analyzed in only one direction. The general formula developed may be used to analyze the system in the other direction by simply changing the subscripts.

Assume the actual radiated power from the remote survey site to be  $P_{ts}$ . If the relative power gain of the transmitting antenna is  $G_{ts}$ , the effective radiated power ( $P'_{ts}$ ) is

$$P'_{ts} = P_{ts} G_{ts} \text{ watts}$$

and the field strength at the relay site is

$$P_{rr} = \frac{P'_{ts}}{4\pi d_1^2} \frac{\text{watts}}{\text{meter}^2}$$

in which  $d_1$  is the distance from the remote survey site to the relay site in meters. This power density is converted to watts by multiplying  $P_{rr}$  by the effective aperture of the relay receiving antenna  $A_{rr}$ . The effective aperture of any antenna system is

$$A = \frac{\lambda^2}{4} G \text{ (meters)}^2$$

in which  $G$  is the relative power gain over an isotropic radiator.

If the wavelength ( $\lambda$ ) is assumed to be 10 meters the effective power received by the relay site antenna,  $P_{rr}'$  is

$$P_{rr}' = (7.96) P_{rr} G_{rr} \text{ watts}$$

in which  $G_{rr}$  is the relative power gain of the relay receiver antenna.

If the relay site antennas are perfectly matched, one-half of  $P_{rr}'$  will be radiated from the relay station because of the maximum power transfer theorem. Therefore, the effective power radiated from the relay site is

$$P_{rt}' = (3.98) P_{rr} G_{rt} \text{ watts}$$

At the interrogation site the receiver has a sensitivity of one microvolt across 50 ohms for a 10 decibel signal-to-noise ratio. One microvolt across 50 ohms corresponds to a power of  $(2) (10^{-14})$  watts. Therefore, in order to have a signal-to-noise ratio of 10 the power input to the receiver,  $P_{ir}''$ , must be  $(2) (10^{-14})$  watts.

The effective power  $P_{ir}'$ , at the interrogation site is given by

$$P_{ir}' = \frac{P_{rt}'}{4\pi d_2^2} 7.96 G_{ir}$$

in which  $G_{ir}$  is the gain of the interrogation receiver antenna relative to an isotropic radiator, and  $d_2$  is the distance in meters from the relay site to the interrogation site.

For sample calculations, typical values will be chosen as follows,

$$d_1 = 3 \text{ miles} = 4830 \text{ meters}$$

$$d_2 = 5 \text{ miles} = 8050 \text{ meters}$$

$$G = G_{ts} = G_{rr} = G_{rt} = G_{ir} = 10 \text{ decibels above an isotropic radiator}$$

$$P_{ts} = 0.1 \text{ watt}$$

$$\text{wavelength} = 10 \text{ meters}$$

When the antenna gains are given in decibels the relative gain is given by

$$G = 10^{G(\text{decibels})/10}$$

With these assumptions the equation for  $P_{ir}'$  reduces to

$$P_{ir}' = \frac{(0.201) (P_{ts}) G^4}{d_1^2 d_2^2}$$

and for this case

$$P_{ir}' = (13.3) (10^{-14}) \text{ watts}$$

The maximum power transfer theorem says that

$$P_{ir}'' = \frac{1}{2} P_{ir}$$

Therefore,

$$P_{ir}'' = (6.7)(10^{-14}) \text{ watts}$$

This amount of power is more than sufficient to give a 10 decibel signal-to-noise ratio. The minimum antenna gains that will give an input power of  $(2)(10^{-14})$  watts into the receiver are

$$G^4 = \frac{(2)(2)(10^{-14})(1.51)(10^{15})}{(2.01)(10^{-2})} = 3000$$

Therefore,

$$G = 8.75 \text{ decibels}$$

The general form of the equation for the power received by the interrogation receiver is given by

$$P_{ir}'' = \frac{\lambda^2 P_{ts} G_{ts} G_{rr} G_{rt} G_{ir}}{(8\pi d_1 d_2)^2} \text{ watts}$$

in which  $\lambda$  is the wavelength in meters,  $d_1$  and  $d_2$  are the distances

from the remote survey site to the relay antennas and from the relay antennas to the interrogation site respectively,  $P_{ts}$  is the actual radiated power from the remote survey site, and the  $G$ 's are the respective relative antenna power gains with respect to an isotropic radiator. As the frequency increases the wavelength decreases but it becomes easier to build antennas with 10 decibels of power gain. The maximum theoretical gain for an antenna with 12 parasitic elements is 15 decibels, and practical values would be nearer 10 decibels, which indicates that  $P_{ts}$  would have to be increased to maintain a constant  $P_{ir}$  as the frequency is increased.

In actual practice the theoretical gains of the system would not be reached. Losses due to impedance mismatches, efficiency considerations, and poor alignment of the antennas would drop the gain figures by at least 30 percent. A 30-percent loss would make the system marginal for the typical application used as an example. Emphasis must be given to the fact that each antenna installation presents its specific problems and rarely if ever are the theoretical specifications met.

The vertically polarized antennas require masts at least one-half wavelength high. Masts several wavelengths high should be used to minimize reflections and interference and to realize maximum gain. Wind and snow loading on this type of antenna installation, although not calculated here, are known to be considerable. Commercial amateur 10 meter antenna equipment designed with sufficient

strength for this application is readily available. The antenna and mast would cost approximately \$130. A cost estimate for the installed remote passive relay is \$500.

Even though the simplicity of such a system makes it attractive, the cost and its limited application indicate that a better solution must be found to the problem in general.

The remaining possibility in ground-to-ground transmission is the use of an active relay. The requirements for such a relay are: reliability, range and compatible power levels, low cost, and ability to work as part of an integrated system.

Typically the commercial equipment available required 110 volt, sixty-cycle power. The relay gear with low power requirements was very expensive when compared with the survey site telemetry equipment. Because of the high power requirement and high cost original development was considered necessary. Development work has been done on a relay designed to meet all the requirements set forth. This relay is a modification of the basic survey site telemetry equipment and, as such, has reliability, accuracy, power levels, and range and cost comparable to the rest of the system. In addition, the design is such that it can be used as a single relay or as one of a series of relays, which makes it valuable in areas like the Uinta mountains of Utah, where information must be transmitted many miles over extremely rugged terrain.

The basic idea of the relay is presented in block diagram form

in Figure 11. Use of the relay involves using two carrier frequencies instead of one as was used when the system involved only the interrogation unit and the survey site unit. The interrogation unit may transmit a 500-cycle-per-second (cps) tone on carrier frequency  $f_1$ , the relay receiver receives  $f_1$  plus the 500 cps tone, and the 500 cps tone modulates the transmitter carrier frequency  $f_2$ . The survey site receiver receives  $f_2$  plus the 500 cps tone. (The survey site receiver is tone selective, and will only cause the survey site transmitter to transmit when the proper tone is received. Here it is assumed 500 cps is the proper tone.) A switch is activated which causes the survey site transmitter to transmit and the survey site receiver to be deactivated. The new modulation corresponds to the amount of water on the pillow. The interrogation unit transmitter is shut off and the active relay receives and transmits the information transmitted by the survey site unit. Both remote receivers are left on continuously and the transmittal times are controlled by thermal relays. The normal transmittal time is about fifteen seconds. The survey site uses one antenna, which is connected to the receiver except when the transmitter is transmitting. At the relay site two antennas are used, since the receiver and transmitter operate simultaneously. The five megacycle separation between  $f_1$  and  $f_2$  is designed to prevent positive feedback from the relay transmitter into the relay receiver.

The basic unit is a transistor transceiver using a super-regenerative receiver. A 30-megacycle commercial transceiver

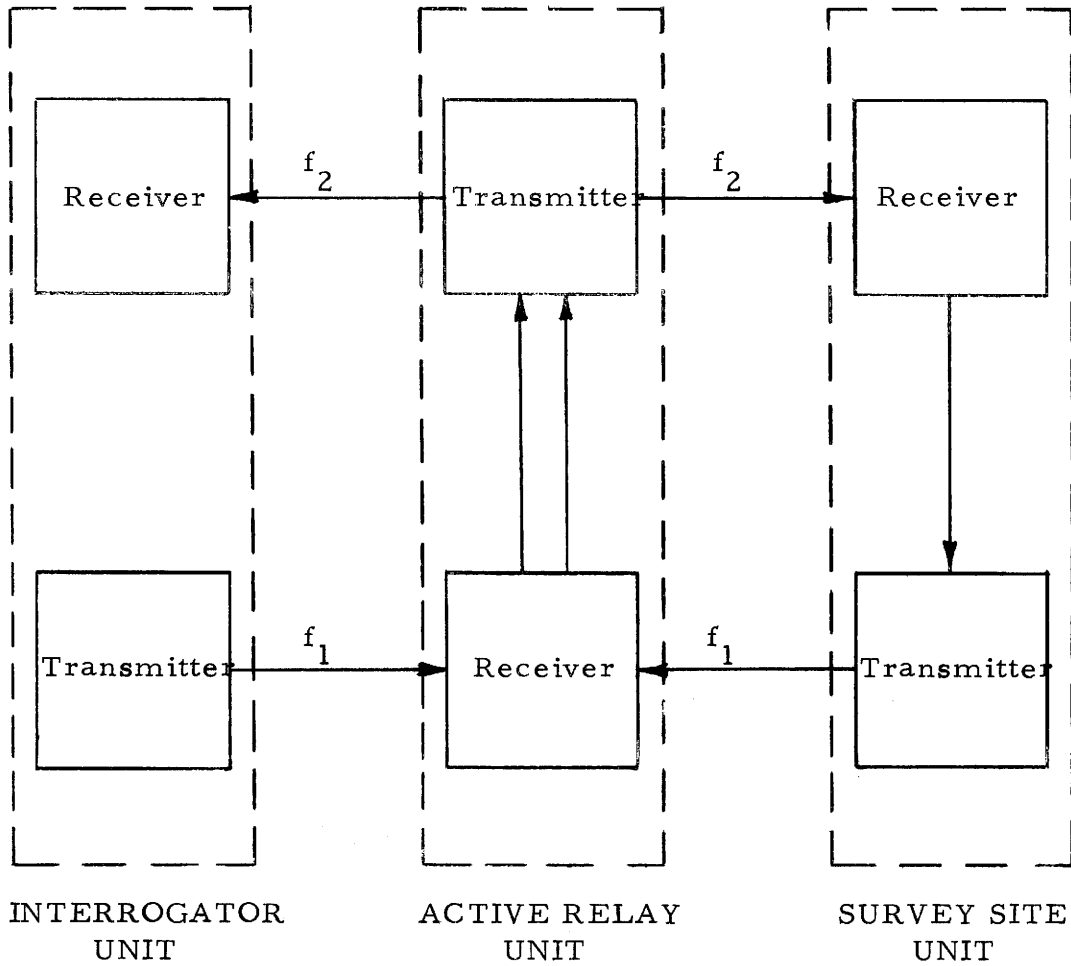

Figure 11. Block diagram of telemetry system using active relay



can be purchased and modified at less cost than a comparable unit can be custom manufactured.

Some problems still exist in the active relay design but the successful work thus far completed indicates that an entirely satisfactory economic relay can be built.

A current cost estimate for the entire system, including one active relay but not including the pressure pillow or the instrument house, is \$1,400. As system development progresses the cost is expected to decrease to \$1,000. The estimated cost for comparable commercial equipment is \$2,700.

It should be noted that one active relay unit can be used with as many remote survey stations as it can "see." One interrogation unit can be used in connection with 25 remote survey sites. By using systems of active relays, every snow survey station in the state could be interrogated from easily accessible places.

An important feature of the active mountain-top relay system is that weather and time of day do not play any part in its operation. It can be interrogated as often as necessary with virtually no additional expense.

The obvious disadvantage of the system is the decreased reliability due to greater electronic complexity. Reliability is limited by the state of the art in miniaturized receivers and transmitters at the present time. However, with the present unit reliability is good enough to make a system of such units practicable.

### Ground to airplane

The final technique investigated was that of interrogation from a fixed wing aircraft. There are no survey sites in the state that cannot be reached from the air. The sites in the Uinta mountains, however, are at high altitudes. The highest is the Jackson Park site listed as 11,300 feet. Use of the airplane for this purpose is not new. In fact sites in the Uintas where electronic rain gages are installed have been interrogated from the air during the past year with great success. Information is commonly received at distances exceeding ten miles.

A map survey of the state snow courses was made with the airplane in mind, and cost figures were developed.

Actual flight time over any given group of snow courses is impossible to judge accurately without actual experience. Assumptions, therefore, are very generous and actual times may be much less than the estimated time. However, since the study is primarily for feasibility, generous estimates will help to account for unexpected headwinds and other difficulties. The assumptions made are that the airplane passes directly over each snow survey site and the average ground speed of the airplane is 150 miles per hour.

In reality the plane will not pass directly over the site but need only have a line-of-sight path to the site.

Possibilities for dividing the state into areas that can be easily covered in a day are numerous. For example, if all the flying is

done out of Salt Lake City, Utah, it would take four days with an average flying time of 4.25 hours per day. If planes flew simultaneously from Cedar City, Provo, Salt Lake City, and Ogden, one day with an average flight time of 3.33 hours would be sufficient.

For safety reasons experienced pilots prefer to take a plane at least as large as a Cessna 210 into the high, mountainous areas. A plane of this size has the added advantage of a fuel capacity large enough for longer trips and emergencies. The cost of a Cessna 210 airplane is \$35 per hour, including the pilot. The cost of four man-days for the operator of the interrogation unit would be approximately \$100. The total cost, if all the flying were done from Salt Lake City, would be approximately \$695. The cost if the four cities previously mentioned were used as flight centers would be approximately \$565.

The use of an airplane has at least two advantages over other techniques. First, there would be a minimum amount of electronic gear involved, hence increased system reliability. Second, flying over the snowpack gives an opportunity to the experienced snow surveyor to see any extraordinary conditions not reported by the instruments. Small aircraft are "fair weather birds" however, and as such cannot be used in storms. Particularly in flood control work many readings are needed in a short period of time and use of the airplane is very expensive.

## SUMMARY AND CONCLUSIONS

The study was concerned with the development and analysis of the transducer. Experimental work has shown the error in the transducer to be a function of ambient temperature and set in the spring.

Temperature correction of the survey site electronic gear is possible. The maximum fluctuation recorded was less than 0.04 inch of alcohol. This type of error can be minimized by reading the instruments at the same time of day each time they are read. In short, the added electronic complexity is a high price to pay for the additional precision in this particular application.

Set in the spring can never be completely eliminated. However, by using high grade spring steel, stressed at one-fourth or less of its rated value and heat treated, this error can be made negligible in the 50-inch transducer. The use of special purpose alloys and exotic heat treatment processes can make the error in the 100-inch system negligible.

If the daily temperature fluctuation is neglected, the error of 0.09 inch of water represents a percentage error of only 0.18 percent of capacity, which is an excellent record. Better accuracy than this is not necessary on a long range snow survey because runoff predictions are based on empirical formulation.

The study was also concerned with the analysis of different transmission techniques on Utah snow courses. Use of wire lines and radio was discussed. Although the wire line has specific application on a few of the survey sites, the advantages of the active relay system and airplane coverage make development of this technique seem unmerited.

The active relay merits further development followed by widespread use as the telemetry system is implemented throughout the state.

The use of the airplane is a tried and proved method of interrogating the survey site equipment. The airplane will undoubtedly continue to be valuable in snow survey work, particularly when monthly or bimonthly interrogation will suffice.

In conclusion, substantial advancement is being made in the art of detecting water content and in telemetering that information.