

CREATING THE FUTURE OF MICROSPACE TECHNOLOGY

L. Flynn², R. Bonometti¹, E. Nicastrì¹, R. Sudol², A. Wheatley¹

¹*DARPA AVSTO*
Advanced Space Technology Program
1400 Wilson Blvd.
Arlington, VA 22209

²*DARPA ASTP SETA*
Space Applications Corp.
1655 N. Fort Meyer Drive
Arlington, VA 22209

The Advanced Space Technology Program (ASTP) at the Defense Advanced Research Projects Agency (DARPA) has recently initiated a series of technology development efforts as part of its drive to enhance the cost effectiveness and responsiveness of defense space systems. These efforts focus on reducing spacecraft size, cost, weight, and power consumption, while simultaneously improving performance. The technology initiatives which are underway span a broad spectrum of efforts at the satellite system and subsystem levels, as well as some which focus on individual components and materials. The technology initiatives which DARPA is pursuing will enhance large, major satellites via technology insertions of cost effective, leading edge technologies in a timely fashion, and will facilitate a new class of small highly capable satellites. This paper will highlight some of the new efforts which have been initiated by ASTP in the past year.

The future of microspace technology is being shaped today - in government, in industry, and in academia. In the past five years, the importance of small space systems for military, commercial, and scientific applications has become widely recognized and accepted. The evolution of technologies has created the foundation for useful and viable "microspace" systems, while the growing needs for dedicated missions and affordable access to space has created the mandate for the "microspace revolution".

As the central research and development organization for the Defense Department, the Defense Advanced Research Projects Agency (DARPA) has been at the forefront of efforts to develop and employ microspace technologies for military applications. DARPA's technology efforts will enhance the strategic and tactical exploitation of space and will improve large defense satellites as well as provide a foundation

for high capability light-weight satellites. The agency has undertaken key technology initiatives which include development of small, responsive, and survivable launch systems; demonstrations of off-the-shelf technologies configured as small satellites for direct support to tactical forces; and a plethora of projects to develop the key enabling technologies for future high capability defense space systems. This diverse array of efforts is managed by DARPA's Advanced Space Technology Program (ASTP).

Over the past decade, the explosive growth in microelectronics has fueled the microcomputer revolution. In the coming decade, microelectronics and microprocessor architectures, together with recent advances in materials technologies and low cost small boosters, will foster what many are today calling the "microspace revolution". One can draw a deeper analogy between trends in the computer and aerospace industries. The power of early computers be-

came available to many users when virtual operating systems were devised to facilitate time-sharing mainframes, and true proliferation of computer power was realized with the development of PC's (Personal micro-Computers). Today, the convenience and diversity of PC's are being combined with the power of virtual systems as a result of the wedding of computers and advanced communications. The anticipated offspring is a networking capability that promises a quantum leap in the capabilities of personal workstations.

The analogous chain of events has occurred in satellite technologies. Early satellites were small and very limited in capabilities. Over the years, spacecraft became larger and longer-lived, and multi-user multi-mission space systems evolved. In recent years, great interest has arisen in the defense, scientific, and commercial space communities for the development of small satellites that would support a limited user base with modest levels of capabilities. Just as with PC's, the key attraction here is a system that is very much affordable and dedicated to support a specific user group. The high technology challenge for the next decade in microspace systems will continue to parallel advancements in information processing systems. Both of these interrelated technology areas will herald the development of advanced networking capabilities that will produce highly accessible, electronically integrated but spatially distributed architectures.

Reducing the procurement costs of military space systems requires radical shifts in the paradigms of space system acquisition culture. Aggressively executed, well-focused R&D is essential for insertion of leading edge technologies into emerging systems. We will need faster system development cycles if the dilemma of multi-year spacecraft development is to be ameliorated. Many of the key concepts to revolutionize the space systems acquisition culture are already being implemented at DARPA and elsewhere. These methodologies include breaking the "one-of-a-kind" mold by modularizing spacecraft, in terms of both hardware and software;

incorporating a common bus philosophy; and standardizing mechanical and electrical interfaces. Progress along the manufacturing learning curve and achievement of economies of scale in production might be realizable if production quantities are sufficiently high.

STRATEGIC FRAMEWORK OF DARPA'S SPACE TECHNOLOGY PROGRAM

ASTP is a technology optimization program for space systems. The program's objective is to develop the key enabling technologies to maximize the capabilities, performance, accessibility, and survivability of military space systems, while simultaneously minimizing their cost, size, weight, and power consumption. A key equation in the optimization problem is to reduce overall costs-to-orbit by leveraging advanced technologies to decrease spacecraft mass and volume (at constant or increasing levels of capability), thereby reducing the throw-weight constraint on the launch vehicle.

The strategic framework for the Advanced Space Technology Program has several major components. First, advanced technologies can facilitate militarily responsive space capabilities, to include quick reaction launch systems and satellites that directly support tactical forces on land, at sea, and in the air. Secondly, the leading edge technologies generated by ASTP can lay the foundation for LightSats - a class of small, highly capable satellites which are ideally suited to provide direct support to tactical forces. LightSats are also naturally conformable with the requirements for a rapid crisis reaction capability which is affordable. Crisis reaction missions include augmenting our defense space architecture with tailored capabilities, and reconstituting assets lost by attrition or on-orbit failure.

A third component of the ASTP strategic framework is to foster rapid integration of the latest state-of-the-art technologies into major large defense satellites. Complex spacecraft traditionally require many years to design, fabricate, and

integrate for launch; consequently, they contain obsolete technologies when they are deployed. A large expensive satellite will be designed for many years of on-orbit mean mission duration in order to amortize its high investment costs; so, at end of life, such a satellite is often outdated (often by 10 to 20 years). Large satellites are required to perform vital defense functions and missions, and they will not be replaced by LightSats. Nevertheless, leading edge technology can be space qualified and proven on LightSat test beds, and then integrated into a major capital asset space system. For a multi-year large satellite development program, off-the-shelf technologies can be programmed for employment in a fairly low risk baseline system configuration. Simultaneously, a parallel design is maintained for incorporation of emerging technologies into the final flight configuration, if and only if these latest technologies are successfully qualified, on schedule, in a LightSat implementation. The upshot is a framework for rapid technology insertion in major space systems at acceptable levels of overall risk.

The final element in ASTP's strategic framework is aimed at developing concepts and approaches for reducing the R&D and procurement costs of inherently expensive military space systems. DARPA is experimenting with techniques such as reduced documentation and formal reporting to the Government, and relying on commercial practices and parts, where this is prudent.

ASTP is programmatically organized along three interrelated segments: launch vehicles, LightSat demonstration program, and advanced technology developments. We will briefly highlight the first two segments, while the presentation of the various technology initiatives serves as the main theme of this paper.

DARPA conducted the history-making first flight of the Pegasus Air Launched Space Booster¹ on April 5, 1990. The winged Pegasus booster has opened the door for the United States to attain a truly responsive and survivable space

launch capability for the first time in its history. ASTP's launch segment also has an initiative in a transportable ground launched booster known as Taurus¹. Like Pegasus, the Taurus booster will facilitate a quick reaction launch system that is survivable by virtue of its transportability and proliferability.

The LightSat demonstration program will provide several types of R&D satellites to demonstrate dedicated microspace assets that can provide direct support to tactical forces. The initial demonstration program consists of two types of UHF communication satellites which incorporate currently available technologies to achieve a modest level of tactical utility. (Future LightSats will leverage off emerging technologies to attain significantly greater levels of military utility.) Two MACSATs² will demonstrate global store-and-forward message relay capability for tactical forces, and sensor commanding and data relay. A constellation of seven MICRO-SATs² will demonstrate intratheater communications relay to support tactical operations. A three-phase program has been developed to orchestrate worldwide tactical demonstrations involving all of the Services as well as the United States Space Command.

The demonstration of DARPA's LightSats as tactically supporting space assets was officially initiated on May 9, 1990, when a SCOUT booster successfully launched two MACSAT satellites into polar orbit.

THE NEED FOR AN ADVANCED SPACE TECHNOLOGY PROGRAM

A major impetus behind the origins of ASTP was the need to develop affordable space systems that would be tactically responsive. This motivation for the initiatives which are underway at DARPA will assume ever greater importance and significance during the coming decade.

The US military will increasingly rely on CONUS-based, rapidly deployable, globally mobile forces during the 90's. World events are

precipitating force structure reductions and declining defense budgets. Furthermore, increasing technological sophistication of potential Third World adversaries, as well as the military's role in the Drug War, will require ever greater capabilities in a leaner military community. All of these stimuli will elicit responses from the Department of Defense which are aimed at maximizing the return, measured in units of decisively projectable global combat power, per dollar of defense investment. Perhaps the greatest leveraging factor for the defense community will be exploitation of advanced technologies to achieve military capabilities that continue to be second-to-none in the world, despite the constraints on manpower and austerity that confront us. Tactically responsive space systems are ideally suited to provide the technology leveraging to lighten forces, deploy faster, and ultimately achieve victory in battle. Developing the best mix of advanced space technologies could contribute to reducing the overall costs of our defended "system of systems", without limiting mission performance.

Advanced technologies can help to minimize or alleviate limitations in present defense space systems. Tailored capabilities for crisis responsiveness on quick-reaction timescales requires microspace systems. Launch systems which are affordable, survivable, and responsive must be coupled with high capability, cost-effective small satellites that can be quickly checked out, integrated to their booster, and rapidly brought into operational status immediately after deployment on-orbit. Responsive space systems can provide the right mix of support to tactical forces when and where it is needed, and they can respond to emergency requirements for reconstitution of critical mission capabilities following attack or on-orbit failures.

Perhaps the most important attribute of tactical space systems is accessibility by the forces they support. Microspace systems can provide this vital capability in several ways. First, fairly low cost microspace assets might be proliferated so that access to their mission support functions

need not be restricted or centrally controlled. Direct support is a well-recognized desirable trait for tactical LightSats. Second, tactically responsive space assets might actually be "front-doors" to integrate tactical users into major defense systems. For example, a low earth orbiting communications satellite could serve as a "stepping-stone" to link a mobile tactical commander (operating with a small portable/mobile antenna and relatively low power) with major defense communications satellite systems at geosynchronous altitudes, such as FLTSAT or DSCS. Finally, and most importantly, microspace "TacSats" can be networked amongst themselves as well as with major defense space systems and terrestrial systems. This far-term capability would provide a globally linked, distributed intelligence "virtual system" that would be almost completely transparent to the tactical user. For example, a tactical commander's request for information on weather and terrain could be input to any node of the integrated 4-dimensional battlespace network, and the distributed intelligence in the network would generate necessary taskings to appropriate sensors to collect data. The system output would be a direct and timely report on the requested parameters to the commander in the field.

Survivability of our defense space assets can be greatly enhanced by leading edge technologies which can enable satellites to autonomously react to hostile action. Distributed microspace assets can form highly survivable systems, since they present a difficult and costly targeting problem to an ASAT-capable adversary. LightSats which incorporate advanced microspace technologies can help to enhance the robustness and survivability of the overall defense space architecture.

CURRENT DARPA SPACE TECHNOLOGY INITIATIVES

Over the past year, DARPA's Advanced Space Technology Program has initiated several dozen new efforts along a broad front of technologies. Currently on-going projects include work in

advanced communications technologies; development and application of the most advanced processor technologies and software architectures to space systems; spacecraft design, subsystems and components; and work in other applications including environmental sensing.

Most of these new initiatives have resulted from industry responses to a DARPA Broad Agency Announcement, which called for proposals for advanced space technologies to reduce the cost of space systems while simultaneously enhancing the availability and responsiveness of military space systems, particularly to tactical forces. Of the large number of proposals that were evaluated, those with the highest payoff in terms of military utility, potential to reduce costs, and advancement of space technological capabilities were selected for funding. In the review process, technical and operational experts from throughout the Department of Defense and from other Government agencies were called upon to assist in selecting those key enabling technology developments that would make a difference in defense space capabilities and cost-effectiveness for the coming decade and beyond. The following sections will highlight many of DARPA's latest space technology initiatives.

Military Satellite Communications

Space based military communications are typically in the UHF, SHF, and EHF bands of the spectrum. The ASTP is developing new technologies in each of these bands and extends the useful spectrum into the optical regions with laser communications.

UHF Initiative: The most widely used and, unfortunately, most vulnerable MILSATCOM frequency band is UHF. The Multiple Path Beyond Line of Sight³ (MUBL) communications project will provide interference resistant voice communications between affordable handheld UHF terminals. The concept is basically a single-hop capability (as seen by a given terminal) and may be thought of as an amplifying ionosphere. When

more than one satellite is in view of the communicating terminal pair, there are multiple propagation paths. The modulation and coding system is designed to support this and resist interference from other satellites. In addition to satellites, the MUBL can include high altitude balloons and unmanned aerial vehicles (UAV). Significantly, the handoff from one relay (satellite, balloon, UAV, etc.) to another is transparent to the user.

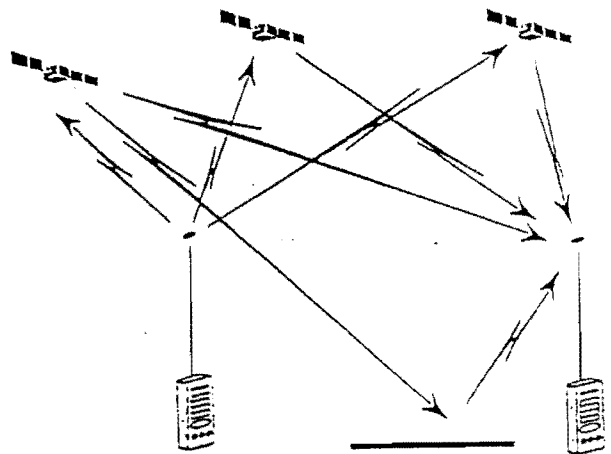

Multiple Path Beyond Line Of Sight Communications

SHF Initiative: The SHF band, while more robust than UHF, has not been fully exploited for tactical use. The ASTP is investigating SHF as specifically applied to tactical communications with the objective of determining which enabling technologies would provide the highest leverage should such a capability be required. The Tactical SHF Communications⁴ study will consider

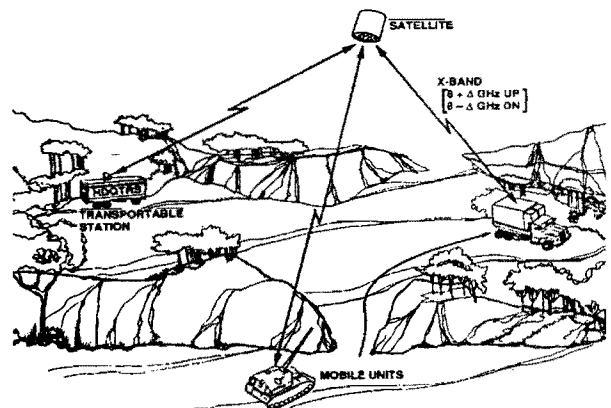

Tactical SHF Communications Concept

the spacecraft bus, orbit determination, spacecraft transponder (payload) configuration, system command terminal configuration, mobile field terminal configuration, and operational issues.

EHF Initiatives: The most promising new near-term technology for protected communications employs EHF (~40 GHz uplinks and ~20 GHz downlinks). The ASTP has three technology projects underway which synergistically complement and support other DoD work in the EHF arena, most notably the MILSTAR system.

The Lightweight EHF Satellite Technologies⁵ project concentrates on the development of system concepts and technologies which, within three years, will provide MILSTAR-like capability similar to the FLTSAT EHF Package (FEP), and will result in a 65% reduction in weight and a 50% reduction in power from the early 80's technology base. Within five years, these technologies will provide another 30% reduction in weight and power.

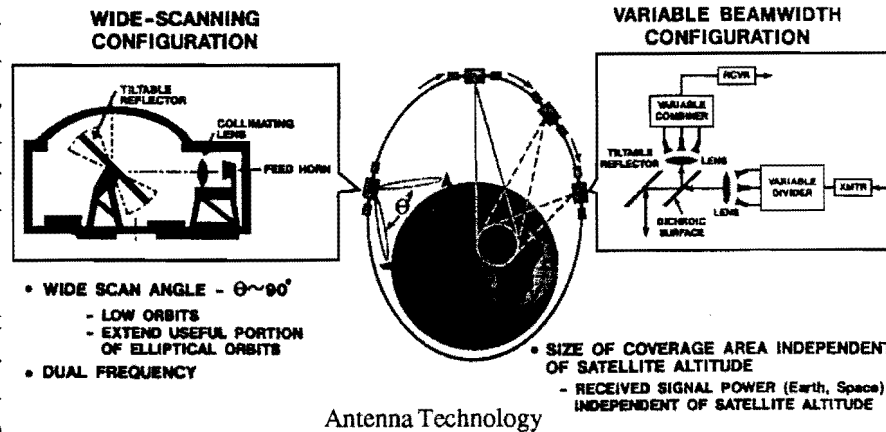

Antenna Technology

dium, and high data rate service, and it appears that the payload weight will be even less than expected, approximately 67 pounds versus 80 pounds. A highly efficient, 2W, 20 GHz transmitting, high power amplifier is being developed -- the baseline version of the solid state module will yield an overall efficiency of at least 35% using a recently sponsored DARPA device, the GaAs Permeable Base Transistor (PBT). The project will also develop and demonstrate a high speed signal processor, a light weight signal generator, and a lightweight wide-scanning antenna.

The Multi-Mode Processing Array (MPA) and 3D Computer⁶ project will develop an EHF phased array communications antenna directly

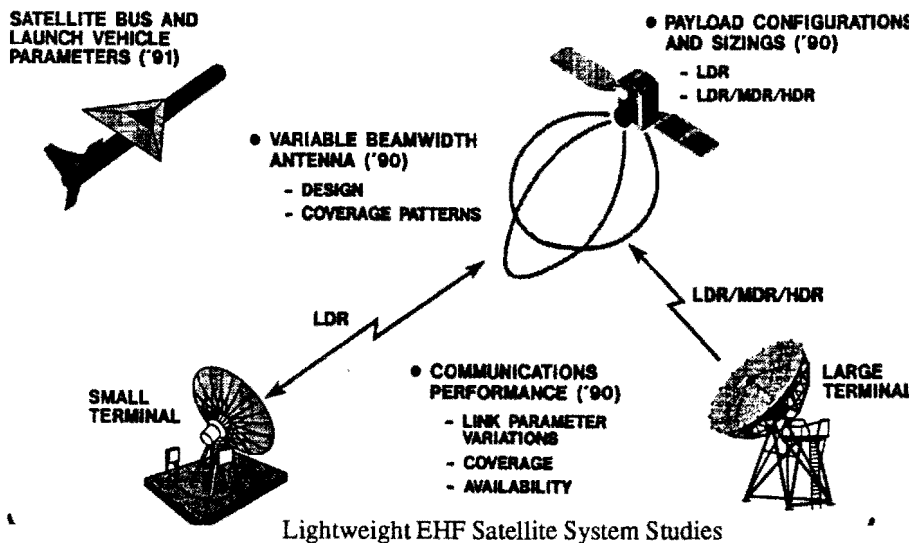

connected to a parallel processing computer packaged as and operated in three dimensions. The project will result in an extremely capable phased array antenna that is 50% lighter than conventional models and at one third the cost. The MPA is a low-profile active array antenna which uses highly integrated circuits and digital beamforming to create

The configuration study on this project has been completed, resulting in the identification of a number of payloads which provide low, me-

ate multiple high-gain agile beams, as well as an active feed network to provide a large dynamic range. The full scale (512 x 512) 3D computer is

projected to weigh-in at 1.1 lbs and measure 12 cubic inches with a throughput of 160 billion operations per second (Gops) using a 10 MHz clock. Potential applications of the MPA and 3D Computer include conformally mounting the antenna on irregular surfaces with the processor accommodating the irregularities, and user-transparent crossbanding (frequency translation) whereby a soldier using a UHF radio can talk to an airman or seaman using SHF or EHF.

of solid dielectric which can provide a graduated index of refraction to form the radiating aperture. Feedhorns are arranged with equal spacing on a concave spherical surface adjacent to the dielectric sphere. To form an electronically scanned antenna, any one of a large number of feeds is excited through an interleaved switch-tree network. This network can combine clusters of horns to perform complex nulling, or it can be used for simple

switched beam operations. The size of the lens depends on the minimum gain requirement (e.g., for 25 dB minimum gain the lens would measure approximately 2.5"). The estimated size of the antenna (lens, horns and switch tree) would be a cylinder measuring 4" x 8".

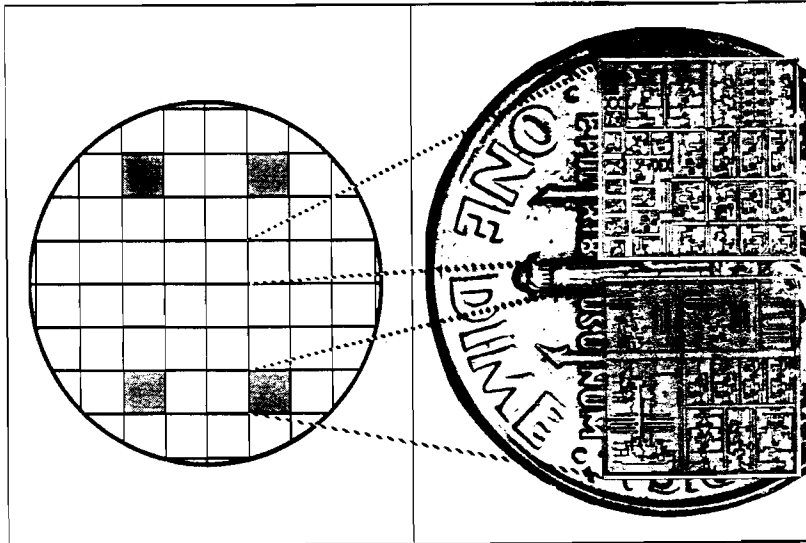

Complete Wafer Layout For MMIC Components

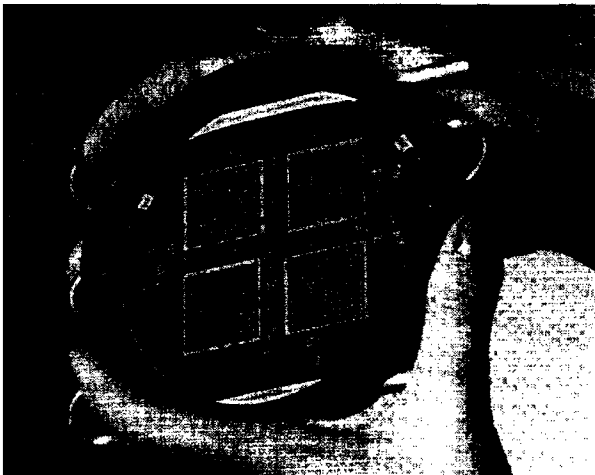

3D Computer, 128 x 128 Mockup

The Spherical Lens Antenna⁷ project has as its objective the development of a wide field of view, electronic scanning, multibeam EHF antenna capable of nulling interfering signals and operating in a variety of orbits, including those that are highly elliptical. The antenna's radiating aperture is a sphere

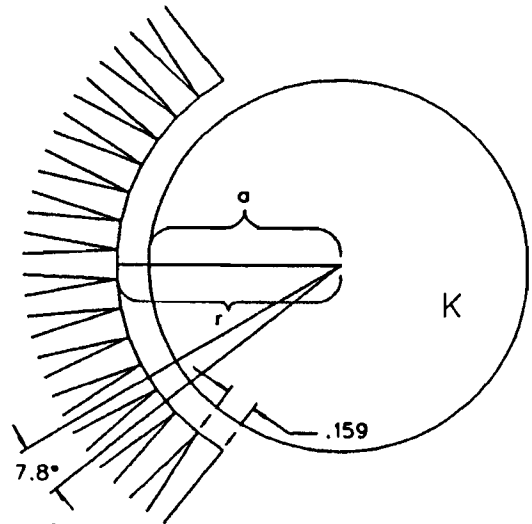

Spherical Lens Antenna Concept

Laser Communications²¹: The UHF, SHF and EHF bands are used for surface and airborne communications. For submarines, laser communication offers timely message de-

livery at useful data transmission rates in an expanded operational depth and speed envelope. Current submarine communications can be enhanced through the use of blue-green laser technology. A submarine laser communications system requires small, lightweight, prime power efficient lasers, and narrow spectral band, wide field of view optical filters. The ASTP has several blue-green laser projects which address the challenging, key technical issues that could enable a realizable two-way laser communications system.

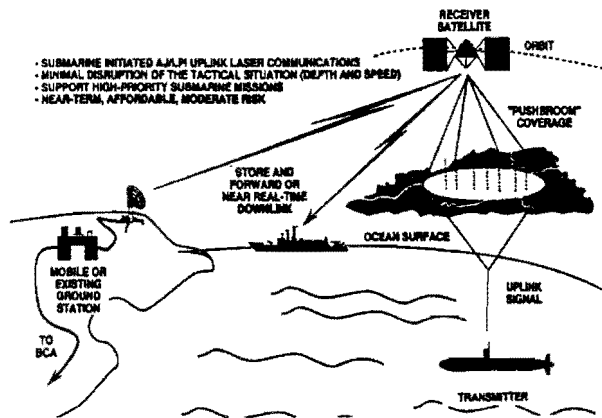

Concept For Laser Satellite-Submarine Communications

Initiatives For Onboard Computing

The basic goal of the Miniaturized, Low-Power Parallel Processor Technology⁸ development project is the reduction, by an order of magnitude, of onboard processor size, weight and power consumption for spacebased sensor systems. Such processors must employ massively parallel architectures with large numbers of processing elements in order to achieve the high throughputs required (up to tens of billions of operations per second or more). The approach for achieving this goal is to use three dimensional hybrid wafer scale interconnect and packaging technology. In this concept individual modules with multiple unpackaged semiconductor chips are compactly interconnected into a high density package with substantial weight and power sav-

ings over existing packaging approaches. Once the size of the processor is reduced, it is possible to use shielding techniques not practical in larger volume equipment, thereby eliminating or reducing the need for radiation hardened components. In addition to the hardware efforts, typical algorithms used in the computationally-intensive portions of sensor processing for spacebased systems will be identified, and the problems associated with partitioning the algorithms among 32 processing nodes will be investigated.

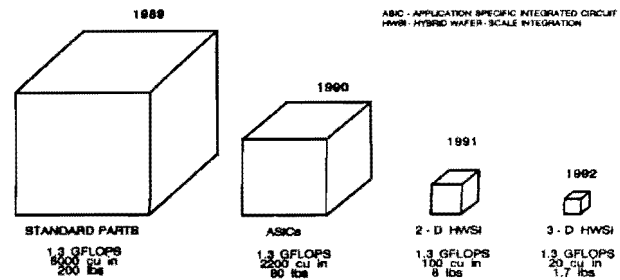

Miniaturized Onboard Processor

Rotating disk memory subsystems have been a leading technology product for many years. They have not been widely applied to space applications, although they represent the state-of-the-art for high density, mechanical memory subsystems. They are less complex and have fewer potential mechanical failure points than traditional spaceborne tape recorder systems. Erasable optical disk technology is especially well suited for space applications due to the high storage capacities available at low volume, weight and power. The objective of the Erasable Optical

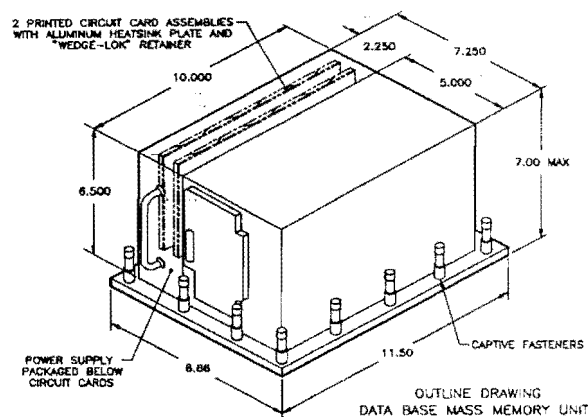

Erasable Optical Disk Packaging Concept

Disk⁹ project is to develop a design for a rotating disk memory subsystem which, as a goal, will provide up to 1 Gigabyte of high speed data storage. The effort will review available optical disk equipment, determine the physical and environmental requirements for operation aboard a spacecraft, and design an enclosure suitable for space flight.

The Optical Data Bus¹⁰ project will design a "universal" interconnect for tying satellite sensors, processors and subsystems together. The bus could replace the dedicated cables (harnesses) now used to transport data between subsystems which will significantly reduce the overall weight of the spacecraft. When fully developed, the bus will be capable of simultaneously transporting a number of different data standards (e.g., Fiber Distributed Data Interface, MS-1553, Ethernet, IEEE 802.5 and Linear Token Passing Bus) over a single optical fiber. The optical implementation provides inherent radiation hardness and a great increase in speed. The optical data bus will operate at a rate in excess of 600 Mbits/second, and when coupled with advanced wavelength division multiplexing, will ultimately operate at one terabit/second (one million Mbits/second) over a single optical fiber.

Spacecraft Components and Subsystems

Mechanical Components: The Lightweight Reaction Wheel¹¹ (LRW) is a magnetically suspended reaction wheel with redundant electronics which will provide two times the momentum of existing units at the same weight, with growth potential to four times the momentum, by using magnetic bearings and faster rotational speed.

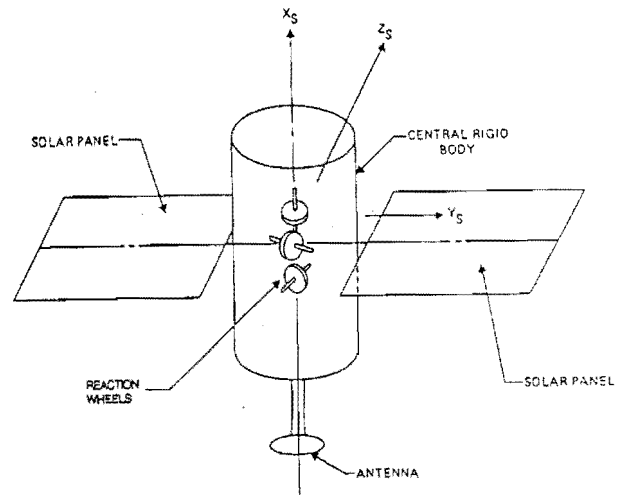

Lightweight Reaction Wheel

The LRW requires 25% less power and can be used on all satellites; its higher speed and reduced bearing vibration can potentially benefit

operation of onboard sensors (e.g., less "blurring" of a sensor's image). This effort will design and deliver a prototype LRW for testing and possible subsequent use on a satellite.

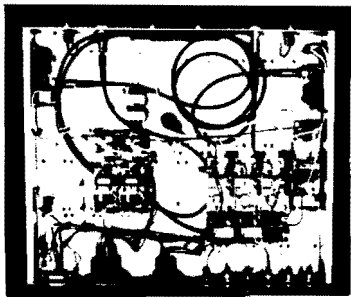

FIBER-OPTIC ASSEMBLY

TRANSMIT

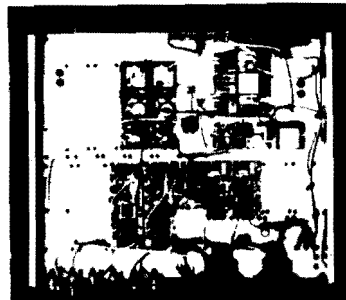

RECEIVE

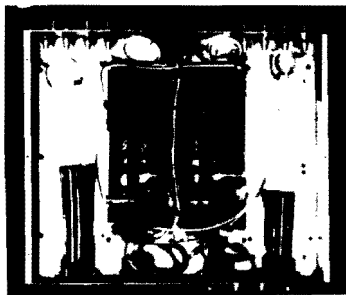

BRIDGE ASSEMBLY



802.3 BRIDGE Fiber Optic Multiplexed Bus Node FDD1/1553 BRIDGE

The Inertial Pseudo Star Reference Unit¹² (IPSRU) project is an effort to develop a single unit for precision pointing and stabilization of optical payloads, i.e., the IPSRU will compensate for mechanical movements thus allowing the incorporation of less-stiff structures which actually weigh less. The IPSRU synthesizes the equivalent of an inertial star (an optical probe beam) that is injected into the path of a payload's telescope. This inertial star will provide the means for closed-loop payload focal plane stabilization to eliminate the effects of jitter and transient distortions due to spacecraft torque disturbances on the focal plane and the telescope structure.

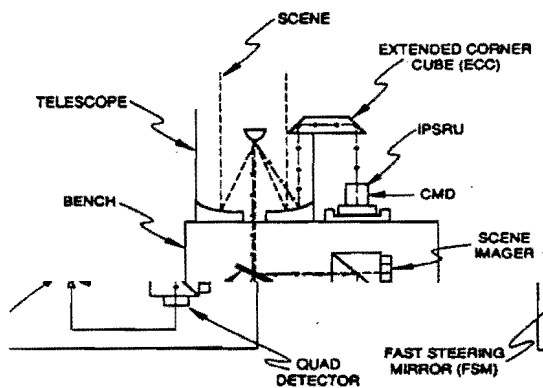

Inertial Pseudo-Star Reference Unit (IPSRU)
(Shown Within Context Of A Complete System)

Propulsion, Power and Thermal: Spacecraft on-board propulsion, power production and thermal management can easily be identified as three of the most critical technologies to be targeted for advancement. The ASTP has development projects in each of these areas.

The ASTP is investigating a simple, high specific impulse electric propulsion thruster as applied to small satellites. The thruster¹³ uses an Electrostatic Plasma Accelerator principle to achieve projected specific impulse levels of order 1,000 seconds. Key features of this concept include the ability to operate directly off the spacecraft bus with little or no power conditioning, and the ability to operate with a variety of propellants including inert gases and hydrazine decomposi-

tion products.

Solar arrays typically provide spacecraft power. Currently, as the amount of power required increases, the size and weight of the solar arrays increase, a situation which necessarily constrains the capabilities of payloads on small satellites. The ASTP's Inflatable Solar Array¹⁴ project aims to make possible space missions that are otherwise impossible by providing increased available power while maintaining small launch volume. A major advancement in the area of photovoltaics was made with the invention of a process to develop flexible sheets of photovoltaics made of amorphous silicon alloys. The thin sheets create a very lightweight and bendable photovoltaic which requires no glass covering. The weight is roughly one tenth the weight of traditional photovoltaic cells. These features are used to advantage by attaching the sheets to inflatables which can be stowed in a compact form for launch and deployed to a large size once the satellite is on station.

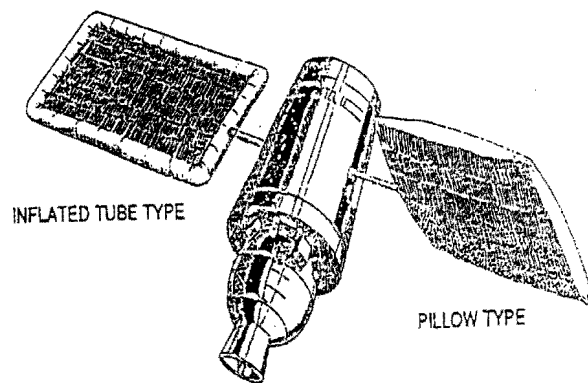

Inflatable Solar Array

An evaluation of thermal control concepts¹⁵ for small satellites with a nominal thermal dissipation of 1 kW is considering five concepts: deployable radiators, thermal storage, heat pumps, variable conductance heat pipes, and integrated structural heat pipes. Critical technologies will be identified and breadboard experiments of critical components will be performed followed by development of a preliminary design for the most

promising concept, and an analysis of its performance.

Optics and Lasers

Existing space based telescopes use mirrors made of relatively heavy single surface materials. The Phased Array Mirror, Extendable Large Aperture¹⁶ (PAMELA) project will develop the technology required to build an active, real time atmospheric compensator mirror that can be both large and lightweight. The specific mass of a PAMELA mirror will be at least four times lower than that of any previous mirror technology. In the PAMELA concept, segments are assembled in clusters which are then joined to form a larger mirror. Each mirror segment is controlled by an integral microprocessor which uses micro-miniature sensors and actuators. Together the segments function as a massive parallel processing network responding to both wavefront errors and local segment edge control.

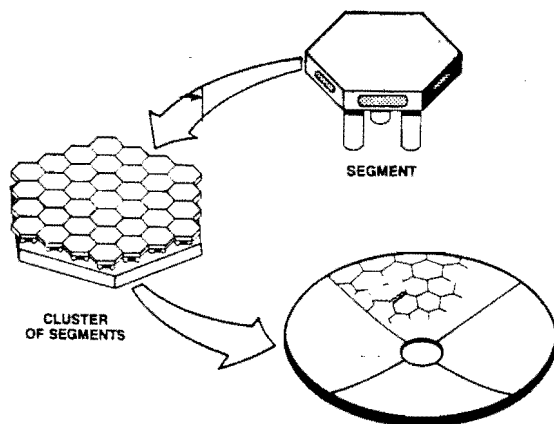

Phased Array Mirror Extendable Large Aperture

The key to the PAMELA technology is proof that the movement of one mirror segment can be sensed relative to adjacent segments. A joint venture between the ASTP and the Strategic Defense Initiative Office has been formed to sponsor the PAMELA technology development effort.

The Laser Scatterometer¹⁷ project will conduct analyses and trade studies to determine the

applicability of such a lightweight sensor to bathymetry, or ocean observation. This mission is best accomplished from space because of the wide field of view required. Conceptually, it is a satellite with a payload comprised of a laser transmitter and a charge coupled detector (CCD) array arranged behind an optical receiver subsystem. By sequentially pulsing the laser and reading the voltages produced by the CCD array as the satellite moves in its orbit, a continuous digitized picture of the reflectivity of the ocean can be obtained which will reveal its topography. A laser system would eliminate synthetic aperture radar (SAR) processing artifacts associated with surface motion and the image data can be read out via a simple line scan system. This means a dramatic decrease in data processing requirements which, in turn, will allow the information to be in the hands of the user in near real time.

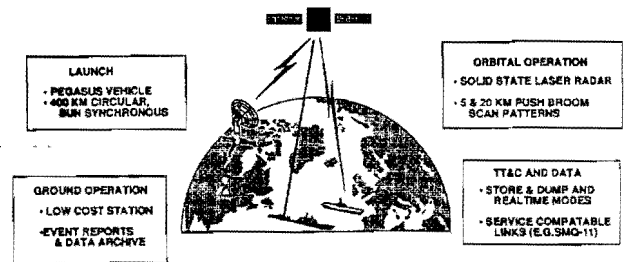

Concept Of Employment For The Laser Scatterometer

Autonomous Guidance, Navigation and Control

The ASTP is developing miniature, versatile, five-channel GPS receivers¹⁸ to provide autonomous orbit determination, continuous carrier tracking, radiation hardened and space qualified chips, L1/L2 capability, and modular input and output. With this receiver, satellite navigation is improved by reducing position and velocity errors. The receiver's mechanical size is reduced to one tenth that of current non-space units, and it requires 50% less power. The receivers will ultimately be integrated into technology demonstration satellites.

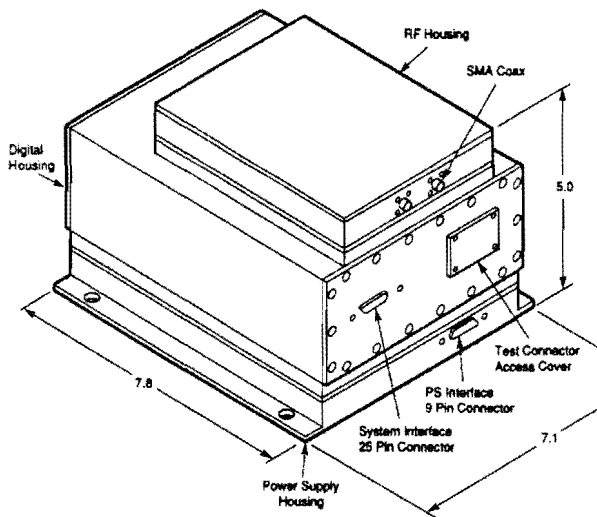

Miniaturized Space Qualifiable GPS Receiver

A single, fully integrated guidance, navigation and control system will be developed on the Attitude Determination, Control and Navigation System¹⁹ (ADCNS) project. The ADCNS will use low cost star trackers, inertial sensors and the ASTP-developed GPS receiver and lightweight reaction wheel. The strap down star tracker is designed to initially determine attitude by recognizing star patterns via an acquisition search pattern (a slow attitude change maneuver) and then to maintain attitude determination in any orientation via nearly continuous star tracking. Low cost, highly reliable fiber optic gyros (also developed at DARPA) are used for attitude determination during high slew rate maneuvers, smoothing between star sightings, and rate stabilization. Spacecraft autonomy is maintained by using GPS

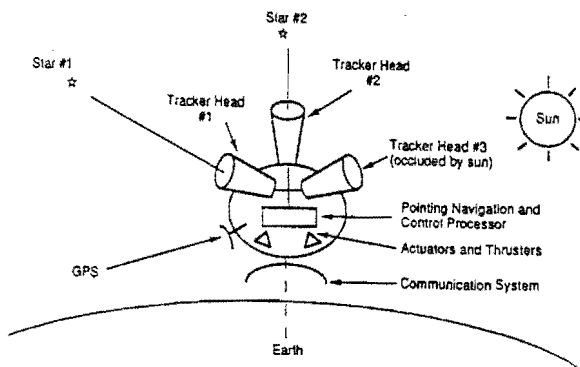

Autonomous Attitude Determination, Control and Navigation System

for navigational updates about once per orbit. Advantages of this project include a star pattern recognition algorithm which eliminates the need for an initial attitude acquisition sensor (i.e., no sun or earth sensor is required) and generic applicability to all 3-axis stabilized spacecraft.

ASTP Space Technology Symposium And TECH NOTES

Several other ASTP projects are currently in the procurement process and cannot be discussed at this time. Additionally, space limitations in this paper prevent a detailed description of the technology initiatives -- each one could easily require a full-length paper of its own for an in-depth discussion. To provide a greater level of detail to the space community, and as a means of insuring technology transfer to users, the ASTP plans to host a multi-day conference in late 1990 or early 1991. At this conference, each of the contractor teams responsible for ASTP projects will provide relevant details about their work. In addition, we plan to institute a series of *ASTP TECH NOTES* which will report on the continuing progress of the technology initiatives.

SIGNIFICANCE OF THE TECHNOLOGY INITIATIVES

Future high capability space systems will evolve from the foundation of key enabling technologies currently being developed by DARPA's ASTP. Many of the current projects have wide-ranging applicability to large satellites as well as microspace systems, and possibly even to ground systems. For example, many of the leading-edge advances in millimeter wave (EHF) technologies which DARPA is presently sponsoring could be applied to help make large satellites using EHF systems achieve smaller, lighter, and less power consuming configurations. Additionally, these same technologies can facilitate small EHF satellites, and can also help reduce the size, weight and power consumption of EHF ground terminals.

Significant military utility will be realized from the capabilities which DARPA's technology work will foster. Decreasing the cost of military space systems, while enhancing their accessibility and responsiveness for both strategic and tactical missions, will be critical developments for the defense community in the nineties.

Finally, DARPA's space technology efforts are synergistically coupled to other key programs. The Strategic Defense Initiative Organization, the National Aeronautics and Space Administration, and the Services' space communities are all interested in reducing cost, size, and weight of space systems, while maximizing mission utility. The technologies being developed by DARPA will benefit multifarious users and their space missions.

PROSPECTS FOR FUTURE SPACE DEMONSTRATIONS

With the support of the Services and other DoD agencies, the array of ASTP technology products will be demonstrated in the laboratory of space in the near- to mid-term future. These demonstrations will aim at achieving proof-of-principle experiments for the leading edge technologies which are currently in development, while simultaneously demonstrating bonafide defense utility via integration of R&D satellites into military exercises. One potential high-tech test bed would be a demonstration of quantum leap technological capabilities in an EHF communications payload, supported on a LightSat bus that includes advanced guidance, navigation, and attitude control (autonomously, with GPS updating); inflatable solar arrays; a leading edge antenna system (MBA or phased array) directly driven by a parallel processing computer; and other innovative subsystems.

The true measure of success for a technology development effort is transition of the R&D product to a user for incorporation into an operational system. As we have noted in this paper, ac-

complishing highly successful demonstrations and technology insertions on a rapid timescale is a paramount objective of the Advanced Space Technology Program.

ACKNOWLEDGEMENT

We wish to thank the ASTP contractors, whose work we have described, for assistance in documenting their projects. We also thank the many contracting agents throughout DoD, as well as the ASTP SETA Team²⁰, for many hours of diligent efforts which were necessary to implement the host of projects managed by ASTP.

REFERENCES

1. Pegasus and Taurus, Orbital Sciences Corporation.
2. MACSAT and MICROSAT, Defense Systems, Inc.
3. Multiple Path Beyond Line of Sight Communication, Thomas S. Seay Inc.
4. Tactical SHF Communications, Jet Propulsion Laboratory.
5. Lightweight EHF Satellite Technologies, MIT/Lincoln Laboratory.
6. Multi-Mode Processing Array (MPA) Antenna And 3D Computer, Hughes Space & Communications Group.
7. Spherical Lens Antenna, Electromagnetic Sciences, Inc.
8. Miniaturized, Low Power Parallel Processor, Space Computer Corporation.
9. Erasable Optical Disk, Spectrum Research.
10. Optical Data Bus, General Dynamics.
11. Lightweight Reaction Wheel, TRW.
12. Inertial Pseudo Star Reference Unit, The Charles Stark Draper Laboratory, Inc.
13. An Electrostatic Plasma Accelerator Propulsion System for Small Satellites, Electric Propulsion Lab., Inc.
14. Inflatable Solar Array, L'Garde, Inc.
15. Evaluation of Thermal Control Concepts

for Small Satellites, Dynatherm Corporation.

16. Phased Array Mirror, Extendable Large Aperture, Kaman Aerospace Corporation.

17. Laser Scatterometer, United Technologies Optical Systems.

18. Miniature Space Qualified GPS Receiver, Rockwell International Satellite & Space Electronics Division.

19. Attitude Determination, Control And Navigation System, Honeywell Systems And Research Center.

20. ASTP SETA Team consists of Space Applications Corp, CONATEC, and BETAC.

21. Multiple projects and contractors under the auspices of the Office of Naval Research, San Diego