

# AN ADAPTABLE FRANGIBLE SEPARATION JOINT

Gary N. Harris  
Orbital Sciences Corporation  
Dulles, VA

Steven L. Renfro  
Ensign Bickford Aerospace Company  
Simsbury, CT

## Abstract

Controlling the level of contamination for sensitive spacecraft instruments during launch and fairing separation has long been a concern for the aerospace community. Reducing the cost of such systems is critical to successful incorporation into Small Satellite applications. Orbital Sciences Corporation and Ensign Bickford Aerospace Corporation have developed a low-cost, adaptable frangible separation joint for these applications. This new frangible joint merges innovative fabrication techniques and proven expanding tube technology to produce a system which is highly reliable and adaptable to most spacecraft and fairing interfaces.

This paper will describe the frangible joint system and the unique features which bring about the cost reductions. A summary of the analytical and test results will also be presented. Some current and possible future space applications will also be discussed.

## Introduction

The frangible joint is shown in Figure 1. It utilizes an explosively actuated expanding tube to fracture a solid aluminum ring at a prescribed "weak" feature. The joint utilizes a sealing manifold to provide redundant initiation transfer between Flexible Confined Detonating Cord (FCDC) assemblies and the ends of HNS-IIA Mild Detonating Fuse (MDF). The MDF detonation products expand an elastomeric bladder

compressing it dynamically against a formed stainless steel tube. The high pressure shock wave developed at the tube forces it to a more round shape which fractures an aluminum extrusion along a stress concentration groove. This fracture provides separation without fragmentation or contamination since the explosive products are contained within the manifold and steel tube. The stainless tube, manifold, and half of the extrusion remain with the stage while the other half of the extrusion departs with the fairing or spacecraft.

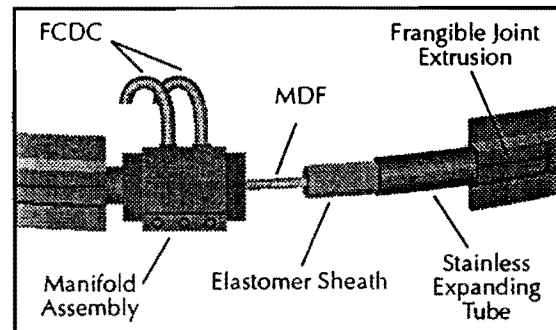

Figure 1 Frangible Joint

Identical flanges on either side of the separation feature provide a shear interface to the stage and spacecraft or fairing. The attach rivet or bolt pattern is dependent on the loading conditions and system constraints.

Through analysis and test, a thorough understanding of the mechanism which severs the aluminum extrusion has been attained.

## Background

The frangible joint was originally conceived to satisfy the need for a lightweight and clean spacecraft separation system as well as provide a clean alternative to the linear shaped charge for separating the base of the Pegasus fairing. Other clean separation systems, the V-band and conventional solid joint, were considered but eliminated because of feasibility and/or cost concerns.

A V-band or Marman clamp design, as shown in Figure 2, utilizes a band or strap to clamp two machined rings together. Cutting the strap and pulling the clamp away radially will allow the two rings to separate. High shear and bending loads require high strap tension which must be reacted by large, heavy rings. It is also difficult to implement V-bands on split-ring type joints found on the Pegasus fairing base.

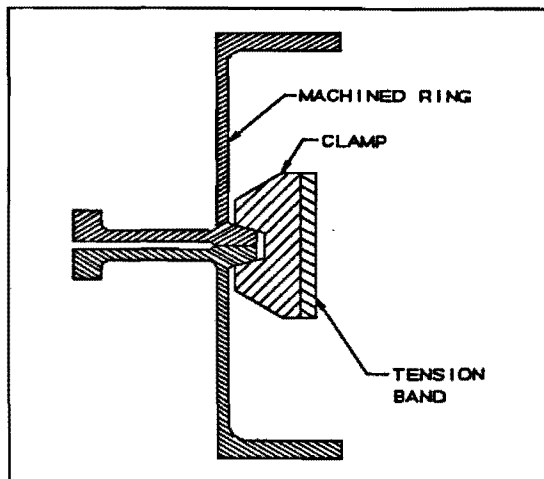

Figure 2 Typical V-Band

A solid joint, as illustrated in Figure 3, utilizing an explosively actuated expanding tube to fracture the joint at a "weak" feature provides a significant strength increase with a corresponding weight and size decrease over V-band systems. Conventional solid joints are typically comprised of machined rings attached with riveted splice plates inside which is located a formed expanding tube. These joints require application specific design, analysis, fabrication drawings, assembly, and qualification testing. In fact, the

cost and time required to adapt one of several available conventional solid joints to this application was found to be nearly the same as starting from scratch and, if pursued, would then yield only one qualified joint design. At least two different diameter joints were desired so most of the analysis, fabrication, and assembly drawings would have to be redone. With all new components, an additional qualification test program may then be required for each size joint.

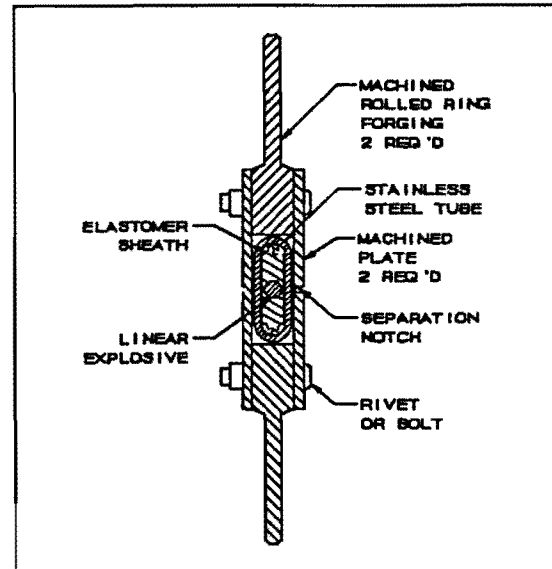

Figure 3 Typical Solid Joint

It became apparent that a solid joint design which utilizes common components regardless of the joint diameter or shape would significantly reduce both non-recurring engineering and recurring component fabrication costs. Knowing that there were several different possible applications which all required different diameter joints made adaptability a critical design criteria for the frangible joint. Indeed, upon successful implementation and flight, the joint has been adapted to separate the fairing base and sides as well as the second stage of the Taurus launch vehicle.

## Frangible Joint Description

The frangible joint developed by OSC and Ensign Bickford utilizes an explosive charge which deforms an oval steel tube to fracture a formed

aluminum extrusion. As shown in Figure 4, the joint cross section expands radially during separation. To prevent interference and damage to spacecraft hardware, a minimum clearance of 3/8 inch is required on both sides of the joint.

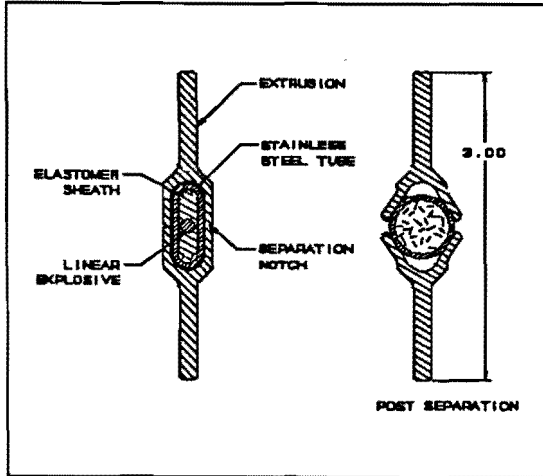

**Figure 4** Frangible Joint Before and After Function

The MDF, sheath, stainless tube, extrusion, and manifold components are identical, regardless of final shape of the formed joint. Application specific hardware will be limited to interface hole pattern drill tools. Application specific engineering can be limited to loads analysis/verification and final formed joint and assembly drawings. This simplified system utilizes common components, therefore providing a much more flexible and cost efficient design over conventional solid joints.

#### Joint Mechanical Characteristics

The frangible joint has a compressive and tensile ultimate line load capability up to 2500 lbs/in. The maximum ultimate shear capability is 1800 lbs/in. The actual capability of the joint is dependent on local interface characteristics. Bending due to misalignment of the external load path to the extrusion center line can significantly reduce the allowable load on the joint. The number and type of fasteners may also affect the load capability of the joint.

Measurements taken during full scale vacuum

chamber tests indicate that a cleanliness level 500 or better is achievable adjacent the joint system. Level 500 can be correlated to the total contaminant accumulation on a surface in a class 10,000 clean room over a 20 day period.

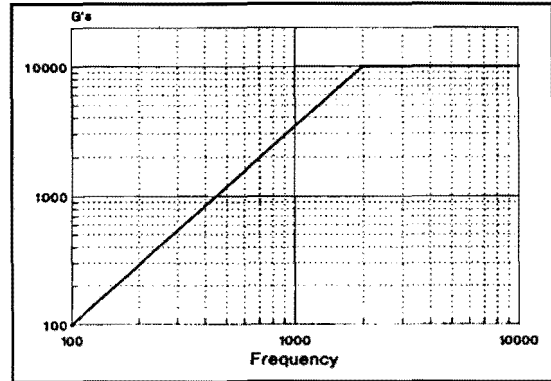

**Figure 5** Shock Spectrum

The joint is designed to function (separate) at temperatures between 0° and 250°F. The assembled joint has been successfully tested random vibration levels of 12 Grms. Pyrotechnic shock from joint separation has been verified and measured during test. The shock spectrum at the joint is shown in Figure 5.

The weight of the loaded joint is approximately 0.10 lb/in. Each manifold assembly weight is approximately .75 lbs.

#### Assembly Process Development

The Pegasus fairing separation joint is made by rolling the extrusion/tube combination into a 50 inch diameter circle. The extrusion and tube ends are trimmed to the proper width for the initiation manifold and the interface hole pattern is drilled in both flanges.

The MDF is inserted into the silastic charge holder prior to installation into the preformed ring. This subassembly is then installed into the stainless steel tube using a process developed by EBAC.

The final step in the fabrication process requires modification of the tube at the manifold interface.

This modification provides a metal seal directly to the manifold without welding or complicated roll crimp operations.

The generic process developed has been shown adaptable to a wide range of size and shape separation joints.

### Scope of Program

The system is initiated through a unique, low profile detonation transfer manifold. The geometry of this system is required by vehicle and payload area constraints. Analysis and testing of the detonation transfer through this manifold is presented.

In order to understand the dynamics of the separation, an analytical model of the frangible joint has been developed. The model illustrates the mechanism allowing fracture of the aluminum extrusion joint while maintaining integrity of the steel tube. The one dimensional model uses the gas pressure of the MDF as an input function with specific attention paid to the response of materials to the detonation. The resultant products create a sharp pressure wave coupled to the elastomeric charge holder. The charge holder attenuates the explosive shock such that the formed steel tube inflates without bursting. The model assumes that deformation of the steel tube creates a concentrated stress in the aluminum joint along the center groove.

The model complements a test program used to optimize the explosive charge for system level requirements. The details of the model and a comparison with the test results are presented later in this paper.

Separation tests conducted early in the development program were used to evaluate the sensitivity to variations in extrusion wall thickness, notch thickness, temperature, and curvature. Tests conducted later in the qualification program demonstrated sensitivity (if any) to charge placement, free volume, initiator gap, tube exposure, and tube damage.

The results from these early tests lead to the following conclusions. Variations in notch thickness up to 14.3% from one side to the other

were demonstrated successfully. This is at least 3 times the worst expected tolerance for the actual extrusion notch. Curvature sensitivity is imperceptible between a 15 inch radius and straight segments. The results of the qualification tests are summarized later in this paper.

Ultimately, failure of the joint to function properly was determined to be primarily dependent on temperature and explosive core load variation. Low temperature, low core load tests failed to properly separate the joint while high temperature, high core load tests caused secondary fractures in the extrusion.

### System Initiation

An Flexible Confined Detonating Cord assembly is used to initiate system function by explosively driving fragments from a stainless steel donor cup across a gap into an explosive MDF acceptor cup. This reaction is entirely contained within a transfer manifold designed to contain the products of the resultant detonation. Redundancy is accomplished by initiating from both ends of the MDF cord. Analysis and testing was done to validate proper transfer of detonation from the FCDC to the MDF. This series of tests demonstrated proper initiation under all gap and extreme core load requirements.

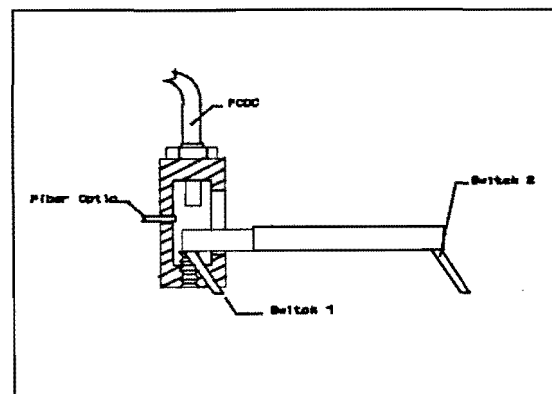

Figure 6 Initiation Test Fixture and Switches

For each test article, as illustrated in Figure 6, an optical fiber was used to obtain the time of arrival of the detonation output from the FCDC. Switches were then used to measure the fragment flight time from the FCDC to the MDF

acceptor and the time for the resultant detonation to reach the end of the MDF length.

The measurement with the first switch had error effecting accuracy. Due to geometrical differences between the location of the first switch and the core of the MDF, a time difference of 0.095 to 0.106  $\mu\text{sec}$  was calculated. In other words, the inherent error of the measurement was around 100 nsec.

The second switch, located on the end of the MDF opposite the acceptor cup, registered the transit time required for the length of MDF used in the experiment. The prediction for this value was obtained by dividing the length of the MDF by the velocity of detonation. Figure 7 compares the predicted times to the actual test data.

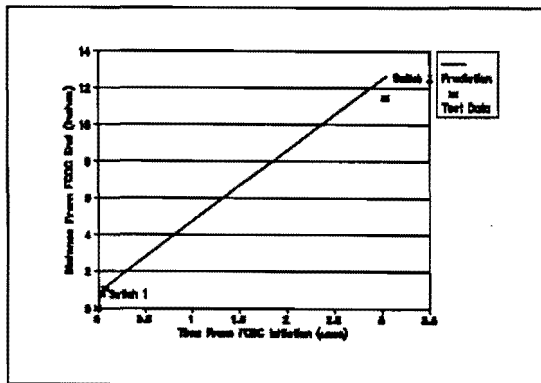

Figure 7 Initiation Test Data

The difference between the calculated value at the point of initiation is the excess time required for the initiation to begin. This excess transit time is most significant because it indicated the promptness of the detonation reaction. A large excess transit time indicates that the transferred detonation takes considerable time to develop. This condition indicates a marginal or not properly supported explosive system. This information was useful to assess the explosive performance of the system.

For the tests performed to support this program, prompt detonation reaction was indicated at minimum and a 126% maximum gap condition. This indicates that virtually no excess transit time exists and thus the detonation reaction is well supported.

It is interesting to note that the test results indicate faster times than do the detonation velocity calculations. This can be attributed to fragmentation pattern of the FCDC end tip. The point of detonation was assumed to be the point of the acceptor directly below the FCDC end tip. This assumption in the calculation did not allow for fragments to initiate at different points along the acceptor. Therefore, the lower mass fragments must exceed the velocity of the heavier one piece flyer assumed in the calculation.

### System Functional Modeling

The model developed to describe the behavior of the frangible joint is based on simple shock matching. The behavior of the components are matched according to the published Hugoniot<sup>8</sup> for the materials used in this system. The portion of the Hugoniot used for this analysis is assumed to be linear to concentrate on local effects in order to simplify the relationships. The particle velocity and shock pressure plane is used to determine the shock state of the material interfaces. This method proves to be quite effective at predicting joint reaction.

The functional input for this analysis is the detonation pressure of 1.55  $\text{g}/\text{cm}^3$  HNS-IIA. This Chapman-Jouget<sup>4</sup> state is used as an input for a ballistic burn algorithm. It is assumed that the charge holder compresses to full solid density as the detonation products expand. This expanded volume effect is accounted for as a reduction of pressure using an ideal gas assumption. This volume effect, as well as dimensional volume variations, produce the largest changes in the stress states calculated using this model. The resulting fully expanded pressure is then shock matched using linear approximations of the constituent Hugoniot<sup>8</sup> and their inverses.

Assuming the aluminum sheath to be propelled intact by the detonation products and ignoring pressure-density effects, an initial state for the aluminum sheath can be calculated. The local slope of the Hugoniot was used to approximate this state.

From knowledge of the initial and local inverse states, the pressure and particle velocity of the material intersection can be described.

$$b = m(U) + P \quad (1)$$

$$U_2 = \frac{b_{a1}}{m_{sr} + m_{a1}} \quad (2)$$

$$P_2 = m_{sr} U_2 \quad (3)$$

- $U_2$  = Particle Velocity of State 2 (mm/ $\mu$ sec)
- $b_{a1}$  = Projected Intercept of Aluminum Inverse Hugoniot
- $m_{a1}$  = Slope of Aluminum Hugoniot
- $m_{sr}$  = Slope of Silicone Rubber Hugoniot
- $P_2$  = Pressure of State 2 (kbar)

This methodology is used for each of the material intersections in the frangible joint design. This allows for simple approximation of the pressure and particle velocity states which are then used to calculate the material stress states of the stainless steel tube and the stress riser section of the aluminum extrusion.

#### Results of System Model

The shock states are approximated for the beginning of the silastic expansion through full compression of the charge holder. Assuming simplified linear Hugoniots, single waves, and neglecting rarefaction and reflection, approximation of the stress in the steel and the aluminum can be determined. This stress analysis treated the stainless steel tube as a pressure vessel. In order for the system to work, it is assumed that the stress state in the tube must be above the yield point and below the ultimate strength of the stainless steel. The results using these linear relationships are used to calculate the final state of stress. The stress response tends to an asymptote above 31 grains/ft as illustrated in Figure 8.

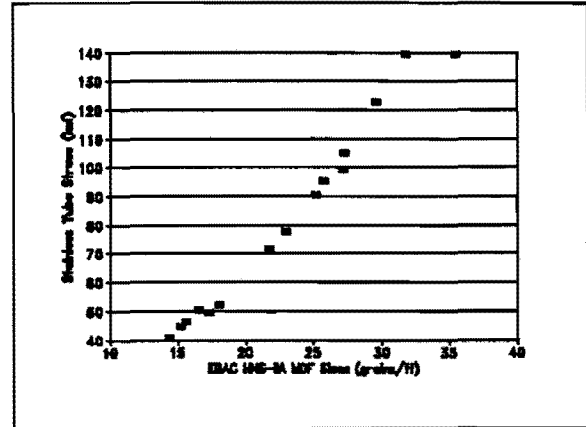

Figure 8 Stress in 0.049 inch Stainless Steel Tube

The model, and its assumptions, are valid for structures made of similar materials. This methodology allows for the designer to easily experiment with materials, cross sectional areas, and explosives for initial parametric study. The analysis predicts that the aluminum will yield, at least, along the stress riser given even the smallest core sizes. This observation is consistent with test results. In other words, even when the extrusion fails to separate, noticeable deformation is observed in the groove.

During the frangible joint development program, tests were systematically conducted in order to select the optimal MDF. The test matrix was entirely interactive, depending on results to dictate the next tests.

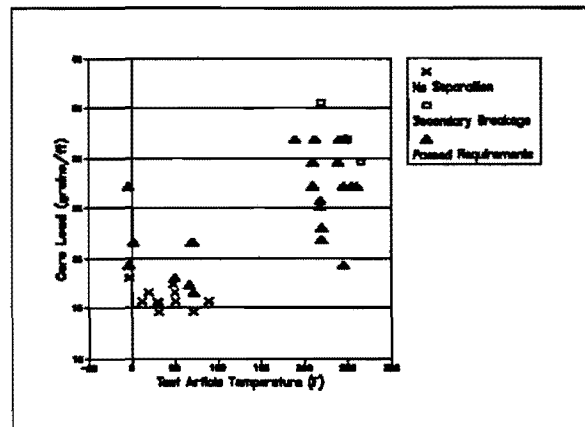

Figure 9 Results of Extrusion Tests as a Function of Temperature

Determining the minimum core load required to reliably separate the aluminum extrusion and the maximum tolerated without secondary breakage were the objectives of this test approach. As Figure 9 shows, the separation threshold was approximately 18 grains/ft.

The threshold for secondary breakage occurs at about 31 grains/ft at 250°F. The core load resulting in secondary breakage decreases as the temperature increases.

### Comparison of Model to Test

The analytical model is used to calculate stress state in the stainless steel tube in order to compare to test data. This comparison is illustrated in Figure 10.

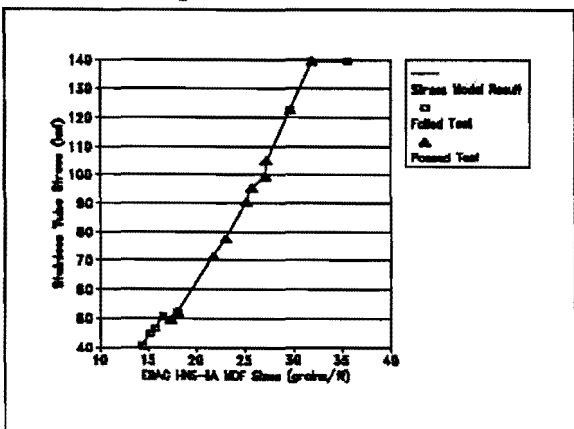

Figure 10 Comparison of Theory and Test Results

The tensile strength of stainless steel is published as 90 ksi<sup>a</sup>. The yield strength is listed as 45 ksi<sup>a</sup>. These values are readily apparent from comparison of the model and test results. Threshold yield occurs when the tube does not expand sufficiently to separate the extrusion. As Figure 8 illustrates, this occurs at approximately 50 ksi. A second calculated stress level correlates with burst of the tube observed in tests. During these tests, this failure threshold occurs between 120 ksi and 130 ksi, therefore, the model agrees with common yield and tensile strength values.

### Qualification for Pegasus Joint

The detonation transfer within the manifold was qualified by gap testing. This series was intended as an overtest of the initiation capability of an FCDC to an MDF booster cup.

This series was conducted with a 1 grain HNS-IA output held at a 0.097-inch gap from the MDF booster cup. The maximum gap allowed by the design tolerance is currently 0.076 inch. All of the tests successfully initiated the MDF booster cup and sustained a minimum MDF velocity of detonation of 6000 m/s. This successfully qualified the initiation mechanism.

The system was then qualified based on a series of margin tests. This test series was used to qualify the frangible joint system at extreme MDF core loads at system temperature limits.

Each of the test articles were thermal cycled prior to functioning. Twelve complete cycles were conducted according to the following schedule:

Beginning at ambient the temperature was increased to 250°F minimum at a minimum rate of 1°/minute and held at 250°± 3°F for at least 1 hour. The temperature was then reduced to 20°F maximum at a minimum rate of 1°/minute and held at 20°± 3°F for at least 1 hour. The test article temperature was then returned to ambient at a minimum rate of 1°/ minute.

The tests successfully demonstrated the clean severance of the joint at 0° and 250°F at each 85% and 115% nominal explosive load. These margin tests qualified the system at explosive margin conditions and temperature extremes. In addition, the effects of free volume variations due to tolerances was demonstrated to have little effect on the successful separation of the joint. Samples which had the charge placement and free volume biased to the tolerance extremes separated properly. Samples with the stainless tube notched with 46% of the wall thickness cut away still did not burst when fired. The tube notch test came about due to the desire to post-machine split lines into the formed extrusion/tube combination and there was concern that the tube

may be scratched or notched during this process.

Full scale testing was completed for nominal, 115% and 83% explosive loads successfully. Each test fully separated, contained the detonation products, and did not create secondary fragmentation or excess debris. These full scale margin tests were conducted at ambient temperature conditions at an outdoor test facility.

Though not required for the joint qualification program, subsequent system function tests with full scale joints (nominal core load) on Pegasus and Taurus fairings were successfully conducted in vacuum chambers.

### Discussion

During initiation testing it was observed that the measured transit time was actually faster than that analytical predictions. The velocity of detonation used for the prediction was the actual value measured for acceptance testing and not an assumption. The foil switches pre-triggered the counters, causing the anomaly.

As reported in reference [7], an end tip of this type creates a rather disperse fragmentation pattern. This effect could account for several microseconds of time due to a different point of detonation. The calculations assumed detonation started at a point centered about the axis of the FCDC. This assumption leads to error. In the final analysis, the system performs acceptably and promptly detonates.

The results of the separation margin tests at temperature indicate that an optimal core load is 23.7 grains/ft. This was rounded to 24 grains/ft for production. This system can be shown reliable for temperatures between 0 and 250°F. Calculations for reference [5] indicates that the lowest reliability exists for the highest temperature.

### Future Applications/Implementation

The Frangible joint program has been developed

around the ability to adapt the system to most applications at the lowest cost possible. As outlined previously, this is accomplished by minimizing the re-engineering for each application and utilizing standard components to fabricate the joint. Some of the joint shapes manufactured to date are shown in Figure 11.

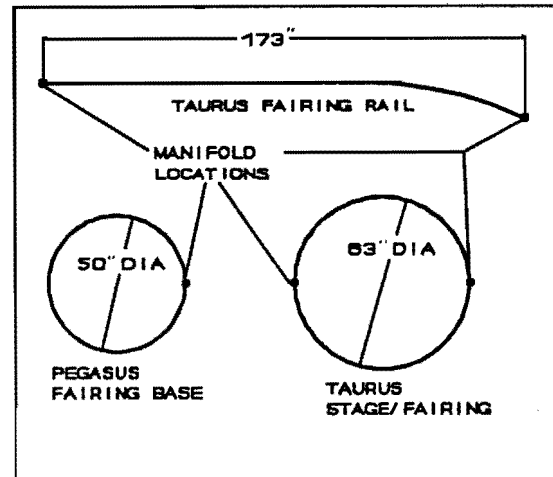

Figure 11 Joint Shapes

The basic process for adapting the joint to a particular spacecraft, fairing, or other separation application is summarized below.

Upon selection of the frangible joint for a particular separation application, the systems engineering team will work with the customer to determine the proper interface and manifold configuration requirements. The structural capability of the joint for the specific loading conditions will also be analyzed by the team. Interface tooling, if required, will be designed and manufactured. The formed extrusion/tube and final assembly drawings will be produced and production will start utilizing the basic components. Structural and functional demonstration testing will be available as a customer requested option.

The total time required to complete the process and deliver flight hardware for a basic joint is expected to be as short as three months from start to finish. The 3 Taurus joint configurations (11 flight joints) were completed within four months of program start.



By developing a totally new process for "clean" separation system fabrication, Orbital Sciences and Ensign Bickford Corporations have finally made this critical technology feasible and cost effective for the small satellite community.

#### References

- 1) R.W. Gurney, "The Initial Velocities of Fragments from Bombs, Shells, and Grenades", BRL Report 405, 1943.
- 2) J.E. Kennedy, "Gurney Energy of Explosives: Estimation of the Velocity and Impulse Imparted to Driven Metal", Sandia Report SC-RR-70-790, December 1970.
- 3) M.J. Kamlet and S.J. Jacobs, "The Chemistry of Detonations. I. A Simple Method for Calculating Detonation Properties of C-H-N-O Explosives, J. Chem. Phys. 49, 23-35 (1968)
- 4) B.M. Dobratz and P.C. Crawford, "LLNL Explosives Handbook", L a w r e n c e Livermore National Laboratory, UCRL-52997 Change 2., January 31, 1985.
- 5) L.M. Richards and M.K. Voisine, "Flash Report - Reliability Assessment Report Taurus Launch Vehicle", Ensign Bickford Aerospace, Report Number 6566-01-92, Rev. N/C.
- 6) "Selected Hugoniot", Los Alamos National Laboratory, LA-4167-MS, University of California, May 1, 1969.
- 7) M.J. Pellon, "Martin Marietta, Titan IV, Space Vehicle-Flight Termination System", Ensign Bickford Aerospace, Report Number 47JD-MJP-03 Rev. N/C, February 16, 1990.
- 8) Metals Handbook, Ninth Edition, Volume 3, "Properties and Selection: Stainless Steels, Tool Materials and Special-Purpose Metals, American Society for Metals, 1980, p. 19, Table 6.
- 9) Aluminum Properties and Physical Metallurgy, Ed by J.E. Hatch, American Society for Metals, 1984, p. 355, Table 3.
- 10) Pegasus Payload Fairing Base Joint Development Final Test Report, OSC-SSD-TD-0152, W. Kim, May 20, 1993