

The MINI METSAT

A Small Low-Cost Advanced Technology Weather System

by

W. David Thompson
Spectrum Research, Inc.

With Contributions from:

William G. Knorr
ITT Aerospace/Optical Division

Jeff Sechrist
E-Systems Garland Division

ABSTRACT

Spectrum Research, the ITT Aerospace Optical Division and the E-Systems Garland Division describe a system design concept for a 350-lb class small weather satellite system which includes a high-performance meteorological imaging instrument and a completely mobile satellite command, control and weather data processing terminal. The system can be made compatible with either civil or military weather data collection and processing systems, and it is interoperable with existing ground terminals. The system permits collection of high-resolution weather imagery in five spectral bands, and can be launched on a variety of lower-cost small space boosters. Applications discussed include cloud imagery, determination of cloud height, soil moisture and sea surface temperature determination, location of sea ice, and thermal IR imaging of wildfires.

INTRODUCTION

In a collaborative effort, Spectrum Research, the ITT Aerospace/Optical Division and the E-Systems Garland Division have developed a concept for a meteorological data collection and ground data processing system that has broad applicability for low-cost remote sensing.

The overall system, as shown in Figure 1, consists of a lightweight spacecraft employing precision 3-axis stabilization as well as high-performance onboard electronics with autonomous navigation and a mobile ground segment. The mission payload is the Advanced Very High Resolution Radiometer (AVHRR) currently flying on the NOAA series of polar orbiting satellites.

MINI METSAT SYSTEM OVERVIEW

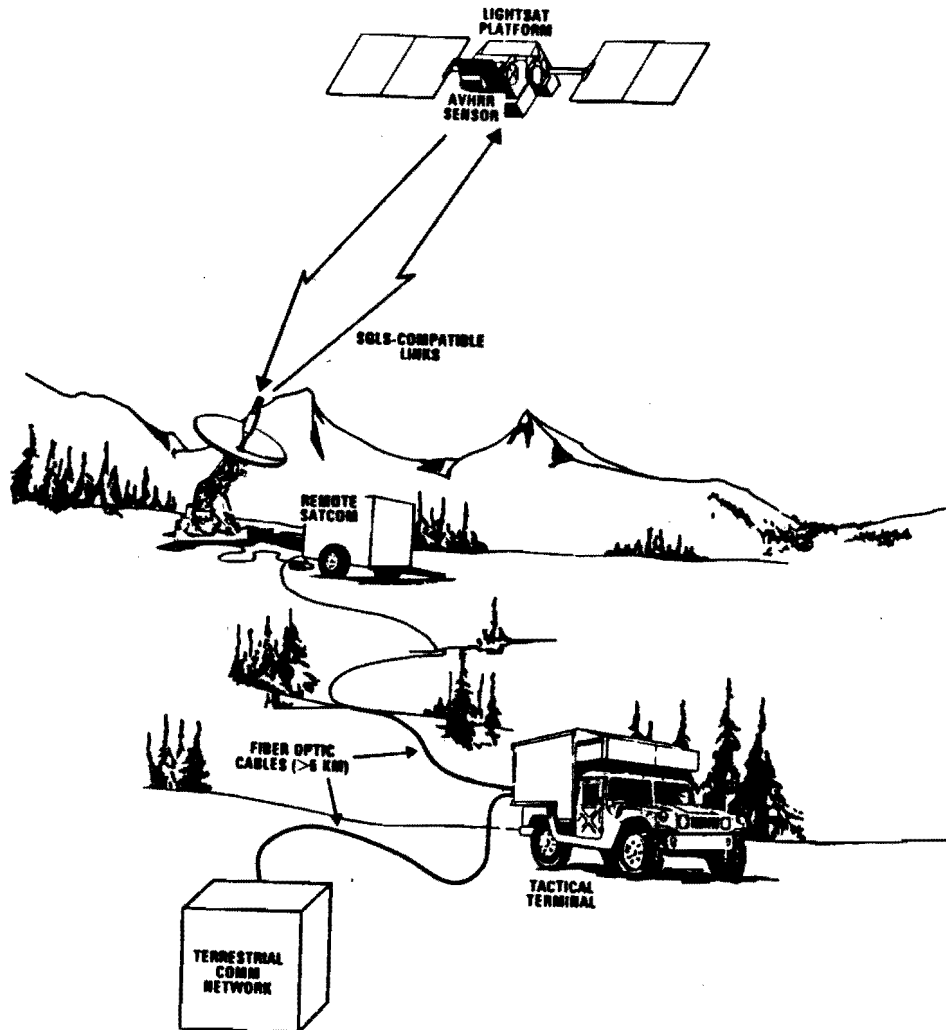

Figure 1. Small Weather System Overview

State-of-the-art technologies, summarized in Table 1, developed for other satellite programs are used to provide a low-cost, low-risk, but high flexibility operational system. AVHRR data is already received and used in over 100 nations worldwide.

<u>SPACECRAFT VEHICLE</u>	<u>MOBILE GROUND SEGMENT</u>
Precision, 3-Axis Stabilization	Miniaturized and Integrated Satellite Communications
High-Performance Onboard Processor	High Performance Telemetry Processing
Autonomous Navigation	Sophisticated Mission Planning & Tasking
Miniaturized and Integrated Avionics	Integrated Imagery/Graphics Workstation Environment
One Mbps Downlink Data Rate	Mobile Operations Provide Flexibility
Small Launcher Compatible	

Table 1. System Features

Spectrum Research Spacecraft

A conceptual space vehicle design, shown in Figure 2, was developed by Spectrum Research, Inc. to provide a small polar-orbiting sun-synchronous spacecraft that can support the AVHRR instrument. The vehicle was optimized for a 450 nmi circular orbit. The deployable fixed-position solar array system is designed to minimize space vehicle disturbance torques and to permit flexibility in the selection of the equatorial nodal crossing times for either morning or afternoon orbits. The total system weight, including the AVHRR instrument, is less than 350 pounds, providing a wide variety of small launcher choices. Through the use of low-power components, the system has adequate power capacity in sun-synchronous orbit to provide a continuous payload data downlink or to facilitate "record and dump" operations. The space vehicle subsystems are modular in design and can be adapted to a wide variety of potential orbits and mission requirements.

The space vehicle design includes the following features:

1. Interoperability with existing NOAA TIROS ground stations;
2. High-Performance computer and memory to support space-borne, autonomous processing functions;
3. Use of Ada programming language for computer software to increase reliability and maintainability;
4. Precision .1 degree 3-axis pointing and attitude control system;

5. Miniaturized LSI telemetry multiplexing and PCM encoding;
6. High-performance GPS receiver for autonomous navigation;
7. Vehicle envelope and weight compatible with several launch vehicles, including PEGASUS, Scout, the Standard Small Launch Vehicle, and others;
8. Highly integrated avionics package to reduce size, weight, power, and cost;

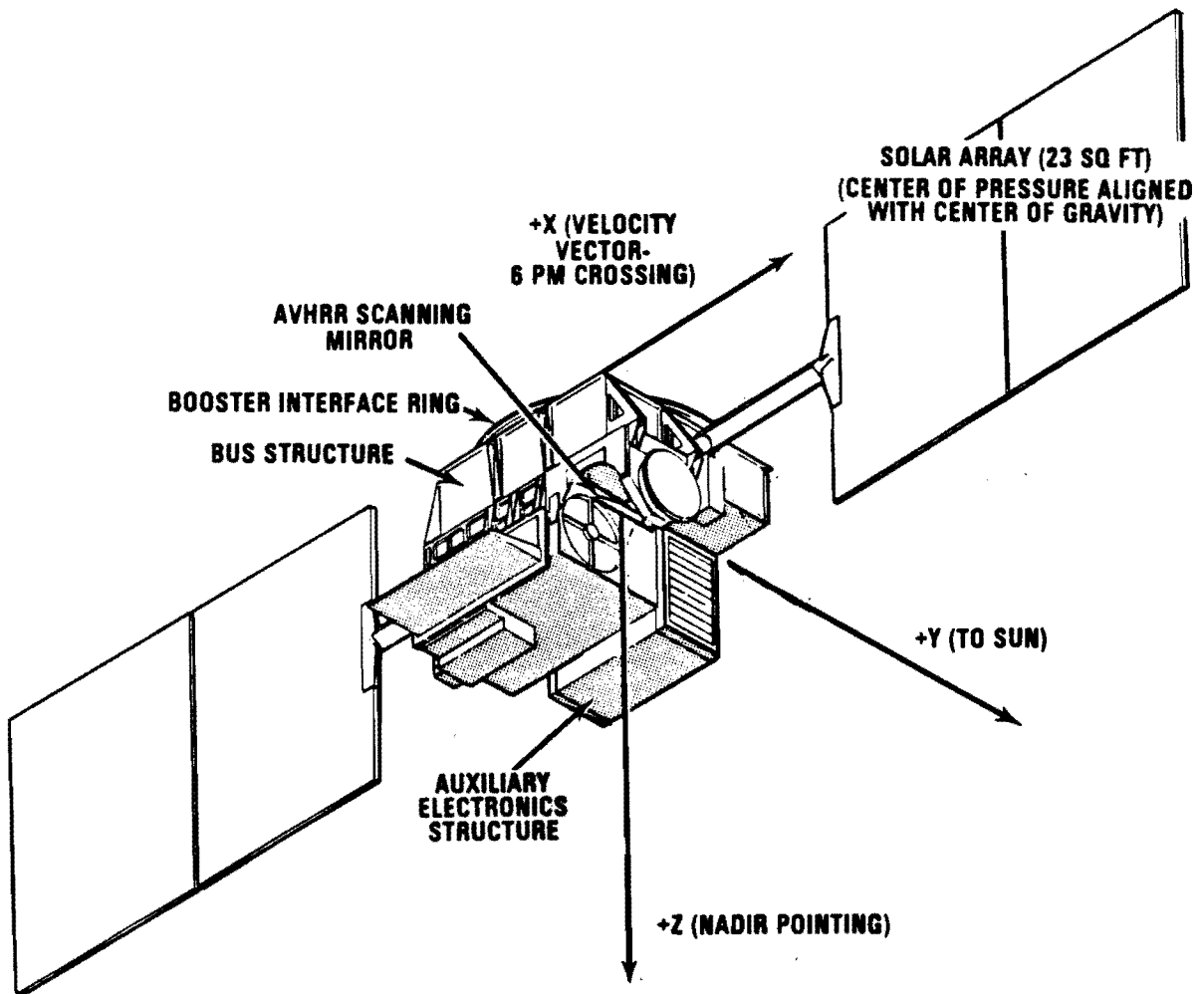

Figure 2. Space Vehicle Configuration

ITT ADVANCED VERY HIGH RESOLUTION RADIOMETER

The AVHRR, shown in Figure 3, is a multispectral imaging radiometer in which a small field of view (1.3 milliradians by 1.3 milliradians) is scanned across the earth from one horizon to the other by the continuous 360-degree rotation of a flat scanning mirror. The orientation of the scan lines is perpendicular to the spacecraft orbit track, and the speed of rotation of the scan mirror is selected so that adjacent scan lines are contiguous at the subsatellite (nadir) position. Complete strip maps of the earth are obtained as the spacecraft travels in a sun-synchronous orbit at a nominal 450 nautical miles. All of the spectral channels are registered so that they measure energy from the same spot on the earth at the same time. They are also calibrated so that signal amplitude is a measure of scene radiance. Solar channels are initially calibrated against a NBS traceable integrating sphere, while IR channels are calibrated against a laboratory blackbody source during thermal/vacuum testing. A passive blackbody mounted on the baseplate provides an inflight calibration source.

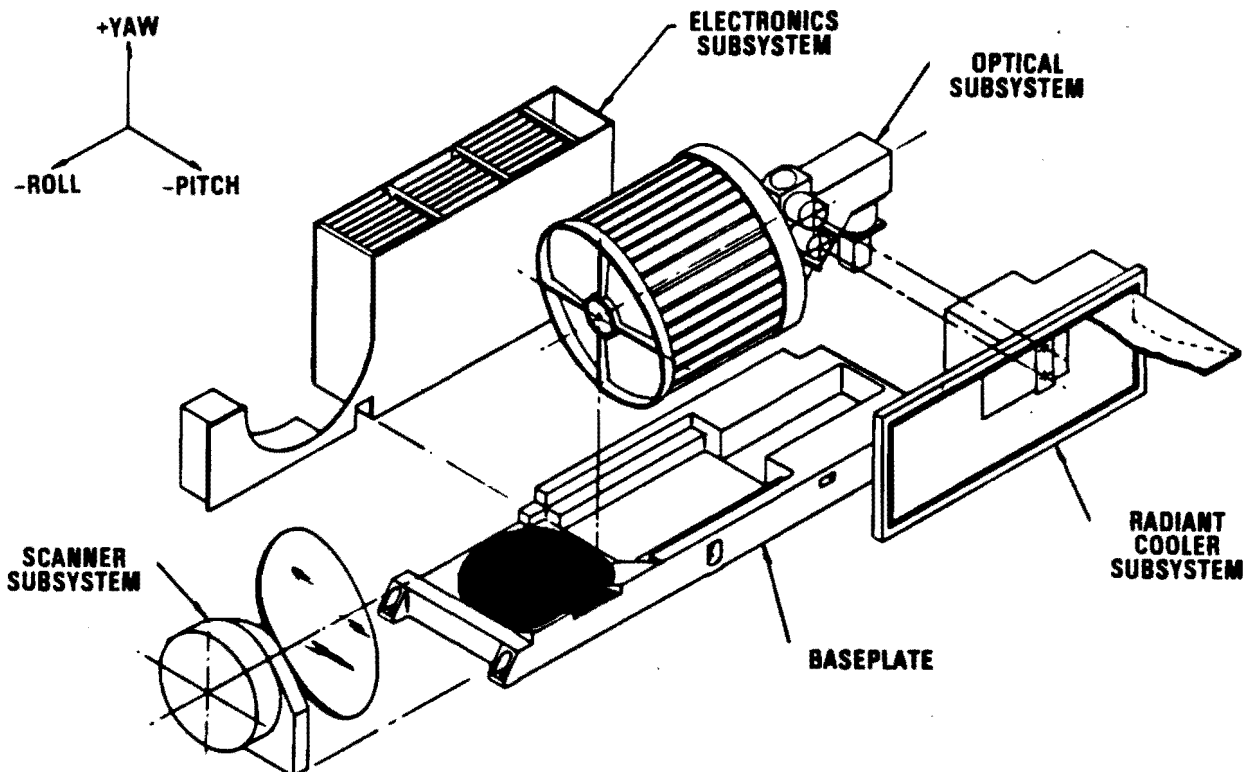

Figure 3. Advanced Very High Resolution Radiometer

In-house studies at ITT were done to investigate modifications of the AVHRR to provide as many as 10 channels and for operations in other than sun-synchronous orbits. The limitations for these modifications are not instrumental but rather are set by the data link. Studies are currently underway for onboard processing and data compaction techniques to overcome these limitations. Spectral channels for the current operational AVHRRs are listed in Table 2 below. Figure 4 below gives the characteristics of the AVHRR-2. Table 3 on the next page provides the physical characteristics of the instrument.

Table 2. AVHRR Spectral Channels

CHANNEL	AVHRR/1	AVHRR/2	AVHRR/3
1	0.58-0.68	0.58-0.68	0.58-0.68
2	0.72-1.00	0.72-1.00	0.72-100
3	3.55-3.93	3.55-3.93	3.55-3.93
3A			1.58-1.64
4	10.5-11.5	10.3-11.3	10.3-11.3
5		11.5-12.5	

* Protoflight AVHRR/1 had a spectral response of 0.55 to 0.90 microns in this channel.

CHARACTERISTICS	CHANNELS				
	1	2	3	4	5
SPECTRAL RANGE (MICROMETERS)	0.58 - 0.68	0.724 - 1.0	3.55 - 3.93	10.3 - 11.3	11.4 - 12.4
DETECTOR	SILICON	SILICON	InSb	(HgCd)Te	(HgCd)Te
RESOLUTION (km at Nadir)	1.1	1.1	1.1	1.1	1.1
IFOV (mrad)	1.3 sq	1.3 sq	1.3 sq	1.3 sq	1.3 sq
SNR (0.5 Albedo)	> 3:1	> 3:1	--	--	--
NOISE-EQUIV (300 K)	--	--	< 0.12K	< 0.12K	< 0.12K
SCAN ANGLE (Deg)	+/- 55	+/- 55	+/- 55	+/- 55	+/- 55
<ul style="list-style-type: none"> • Optics - 8-inch diameter afocal Cassegrainian telescope • Scanner - 360 rpm hysteresis synchronous motor with beryllium scan mirror • Cooler - Two-stage radiant cooler, infrared detectors controlled at 105 or 107K • Data Output - 10-bit binary, simultaneous sampling at 40 KHz rate 					

Figure 4. Summary of AVHRR/2 Characteristics

Power	28.5 watts maximum
Size	31 inches by 11 inches by 16 inches
Weight	65 pounds maximum

Table 3. AVHRR Physical Characteristics

E-SYSTEMS MOBILE GROUND SEGMENT

A conceptual design has been completed for a high-performance ground station which serves not only as a ground-based satellite command and control station, but also as a complete meteorological data processing, display, and data dissemination terminal. The ground station integrates a wide variety of advanced commercial off-the-shelf command, control, and data processing equipment. The ground segment maximizes the use of existing software programs by re-hosting several hundred thousand lines of existing control, meteorological data processing and display software on the system.

The ground segment includes the following features:

- 1) Dual-function mobile ground station - Our ground segment is the command and control element for the space vehicle as well as an advanced weather data exploitation and dissemination terminal.
- 2) Portable Equipment - We have selected ground equipment which has been reduced in size to fit within a shelter transported on a small truck.
- 3) Workstation - A Sun graphics workstation and a VITEC image processor with associated high-resolution displays provide a powerful terminal for meteorological data processing, display, exploitation, and reporting.
- 4) Mission planning and control - The system provides extensive mission planning and vehicle tasking software tools which enable support of multiple small space vehicles performing different missions in different orbits.
- 5) Software Rehosting - We have available up to one million lines of existing relocatable software, including functions of command and control, image processing, graphics processing, AVHRR data processing, meteorological exploitation algorithms, and protocols for interoperable communications.
- 6) S-Band communications compatibility - The design provides interoperability with existing military or civilian S-band command uplink and data downlink transmission systems.
- 7) Imagery dissemination - The design is easily made interoperable with existing and planned civil or military imagery exploitation systems such as the Joint Services Imagery Processing System (JSIPS) and their data interchange protocols as well as the MIL-STD-2179 magnetic tape format.

8) Equipment technology - We have selected satellite communications equipment (i.e. antenna, downlink receiver, ranging receiver, uplink processor, and PCM demultiplexing) which has been significantly reduced in size and weight. This equipment incorporates technologies and components which are a generation beyond those currently employed by civil and military control networks and other available terminal systems but are available now.

Figure 5 below provides an overview of the terminal software functions that our concept incorporates.

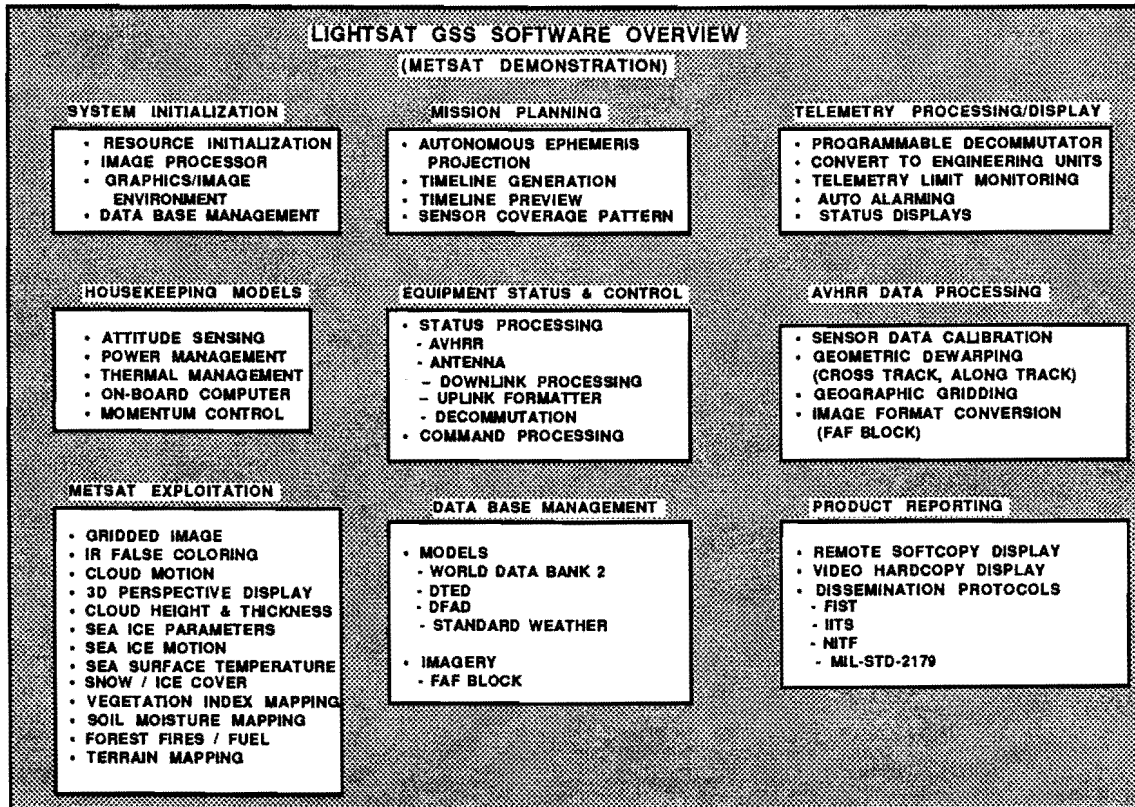

Figure 5. Terminal Software Overview

System Operation

In a typical operation, the satellite could be launched by a PEGASUS booster air-dropped from a carrier aircraft such as the NASA B-52 aircraft. Pre-launch planning based on mission requirements would dictate the time and location of the PEGASUS release point. Once the PEGASUS has achieved orbital insertion velocity, the MINI METSAT will go through an automatic deployment and earth acquisition sequence. Only the solar arrays require a physical deployment sequence. Once the PEGASUS boost phase is completed, the launch aircraft can pass the predicted orbital parameters to the mobile ground terminal. The terminal would then acquire the newly-launched vehicle during its first orbit and begin mission operations soon thereafter.

System Applications

The AVHRR was originally designed for meteorological applications. As applications research has continued, the use of AVHRR data has expanded. The powerful ground processing system proposed permits this system to perform sophisticated meteorological data processing functions. The following are some typical examples of these applications:

Meteorology

We can provide the following functions in support of the overall meteorology mission using the AVHRR data as input:

a) **3-D Perspective Display** - The infrared temperature provided by the AVHRR sensor is a good approximation of the cloud height in the atmosphere. By combining this information with the image from the AVHRR's visible channel, our ground system can synthetically generate a 3-D perspective display of the cloud image. By giving the operator control of the view and perspective points, one can examine the vertical structure of a cloud from a variety of perspectives. Analysis of similar data taken with NOAA's TIROS satellite has shown the ability to discriminate low cloud cover from sea ice. This latter capability is a valuable meteorological product which is difficult to obtain by the typical analysis of infrared brightness temperature alone.

b) **Cloud Height and Thickness** - The temperature of a cloud can be computed from its infrared brightness as measured by the AVHRR. Combined with standard meteorological observations, these cloud temperatures can be converted to height and thickness. With this approach we can provide the capability to determine the convective structure of the atmosphere from the AVHRR imagery.

c) **Cloud Motion** - Sequential images of cloud features can be used to estimate the motion of the atmosphere at the level appropriate for cloud temperatures. Cloud height can be inferred since the infrared brightness measured by the AVHRR is directly related to cloud temperature. Cloud temperature, in turn, is directly proportional to the cloud height in the atmosphere. We can perform a cross-correlation between images to determine the motions of clouds with similar infrared temperatures (i.e. same height) to give the winds at the cloud height.

Oceanography

We can provide the following AVHRR image exploitation capabilities in our ground terminal in support of oceanographic missions:

a) **Sea Ice Parameters** - We can determine ice coverage and extent by comparison of the visible and infrared channel brightness values. By using the various AVHRR channels separately and in combination at different times of the year, we have the capability to identify the sea ice edge, geographic coverage, and to provide an estimate of the sea ice concentration.

b) **Sea Ice Motion** - By using a combination of visible and infrared imagery, we can perform sequential cross correlations to compute sea ice motion. This technique has been used to map ice motion in Arctic regions such as the the Barents Sea and the Beaufort Sea.

c) **Sea Surface Temperature** - The University of Colorado at Boulder (UCB) is currently using AVHRR data for global and local mapping of sea surface temperature. A primary source of error in the computation of sea surface temperature is the correction for atmospheric contamination. We can implement a UCB algorithm which improves upon the current NOAA technique by adding corrections for skin and bulk ocean temperatures and results in a more accurate measure of sea surface temperature, a very important parameter for the Navy.

Terrestrial Parameters

We can include the following AVHRR imagery exploitation functions in our MINI METSAT ground terminal in support of terrestrial missions:

a) **Vegetation Index** - The most widely used terrestrial vegetation product generated from TIROS AVHRR data is the Normalized Difference Vegetation Index (NDVI). We can use a combination of the visible and near-infrared channels on the AVHRR to generate a NDVI which corresponds to both the green in plants and the health of the plant canopy. The NDVI has been shown to be a good monitor of space/time differences in terrestrial vegetation. This information is a vital input when determining the soil moisture and trafficability of an area.

b) **Snow Cover** - We can use the AVHRR imagery to map snow cover and to discriminate snow from other terrestrial features.

c) **Forest Fires and Other Fires** - The AVHRR has been used to monitor the formation, spread, and consequences of forest, range, and marshland fires. We have the capability to estimate the sites of active burning from the IR channels while the visible channels display the smoke plume.

SUMMARY

The MINI METSAT System provides an affordable advanced technology system with a wide range of potential applications. The small satellite attributes of low cost and quick launch response can be used to enhance coverage for a specific dedicated user with wide geographic interests. The choice of the AVHRR instrument provides a high performance calibrated imaging radiometer which has many international users and a large number of applications. The mobile high-performance ground station provides a self-contained yet complete satellite command, control and mission data processing environment.