

Low Cost Spacelift to LEO, GTO, and Beyond Using the OSP-2 Peacekeeper Space Launch Vehicle

Scott Schoneman^{*}, Lou Amorosi[†], Ron Willey[‡], and Dan Cheke[§]
Orbital Sciences Corporation
Launch Systems Group
3380 South Price Road
Chandler, AZ 85248

ABSTRACT

The Peacekeeper (PK) Space Launch Vehicle (SLV) is a new launch vehicle for providing cost effective spacelift for small-to-medium, Government-sponsored spacecraft, including addressing an emerging need of small Geosynchronous (GEO) spacecraft. This vehicle is being developed by Orbital Sciences under the Orbital Suborbital Program 2 (OSP-2) contract with the United States Air Force (USAF) Space and Missile Systems Center (SMC) Detachment 12 Rocket System Launch Program (RSLP). Preliminary designs and capabilities were presented at the 2003 Small Satellite Conference. In the year since, there has been significant interest in the PK SLV, and the first missions have been initiated with an anticipated first launch in 2007. In addition to the baseline LEO and MEO orbital missions, a burgeoning interest has been revealed in using a PK SLV derivative to deliver small spacecraft to high energy orbits, such as geosynchronous transfer orbits (GTO) and beyond, including potential lunar missions.

This Peacekeeper Space Lift Vehicle (PK SLV) follows in the heritage of RSLP and Orbital's Minotaur SLV, merging advanced commercial launch vehicle technology with surplus Air Force boosters to provide a low cost, low risk spacelift capability to US-Government sponsored spacecraft. The baseline PK SLV uses the first three Peacekeeper solid-rocket stages in unmodified form, along with the same Orion 38 Stage 4 insertion motor as Pegasus, Taurus, and Minotaur. The avionics design is shared with the other OSP-2 vehicles, including the Minotaur SLV. It also uses the 92 inch payload fairing that was developed and flown for Orbital's Taurus SLV. This combination of common, flight proven avionics and subsystems, along with existing ICBM motors results in a new vehicle that has a very low risk and low cost development.

This paper presents the status and capabilities of this baseline PK SLV system. More significantly, it will cover the development of the enhanced evolution that addresses the development of the capability for delivering relatively small spacecraft to GTO and other high energy orbits. To maximize performance to these high orbits, different upper stage motors have been evaluated and the mechanical design mass optimized.

INTRODUCTION

The Peacekeeper Space Launch Vehicle (PK SLV) is designed to meet the needs of United States Government-sponsored customers at a lower cost than commercially available alternatives by the use of surplus Peacekeeper boosters. The requirements of the OSP-2 program stress system reliability, transportability, and operation from multiple launch sites. PK SLV draws on the successful heritage of four launch vehicles: Orbital's Minotaur SLV, developed

under the OSP-1 contract, as well as Pegasus, Taurus, and the Peacekeeper ICBM systems currently being deactivated by the USAF, as illustrated in Figure 1. The PK boosters were designed and demonstrated for the rigorous, front-line weapon system standards of the USAF. This rigorous strategic defense heritage provides outstanding levels of reliability and capabilities. These well proven and characterized systems are combined with Orbital's state-of-the-art avionics and subsystems. The combination of Orbital's heritage of at least 39 successful space launch missions, five successful OSP Target Launch Vehicle

* Associate Fellow, OSP Mission Manager/
Lead Systems Engineer

† Vice President and Program Director, OSP

‡ Deputy Program Manager, OSP

§ Lead GNC Engineer, OSP

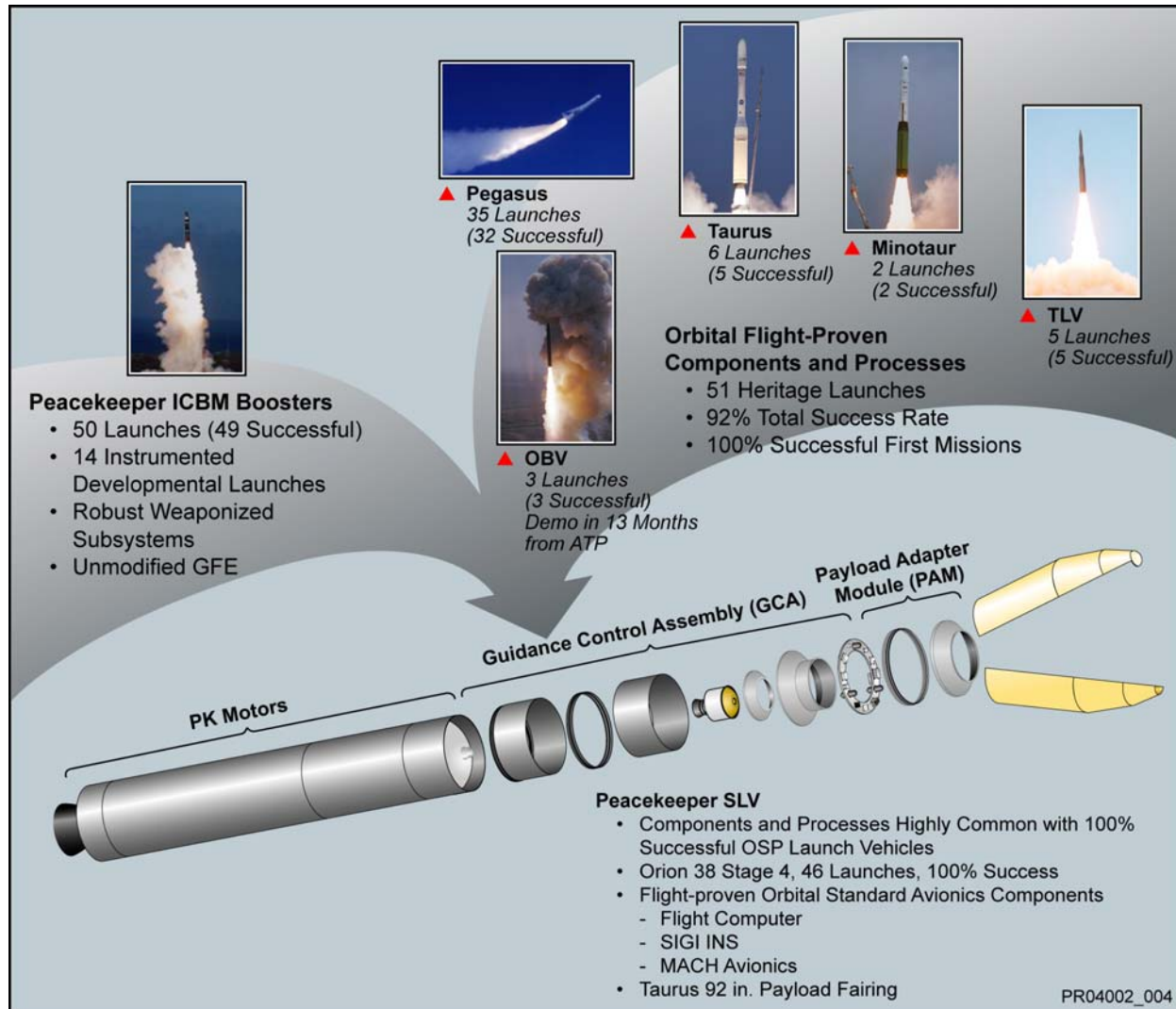

Figure 1 Minotaur IV PK-Based SLV's Extensive Flight Heritage

(TLV) flights, and at least 50 PK test flights makes the PK SLV a “new” vehicle that has a very extensive flight history. The first PK-based launch vehicle missions have recently been initiated with the initial launch as early as the late 2006.

PK SLV's avionics and other subsystems are virtually identical to the Minotaur systems, which in turn have much common heritage with the Pegasus and Taurus systems. The commonality with the original Minotaur systems has resulted in the tentative designation of the PK SLV as “Minotaur IV”, creating a Minotaur family of launch vehicles. (Minotaur II and III have been designated for growth options of the original Minuteman-based Minotaur.) Moreover, the Minotaur-family avionics architecture is serving as the basis for several other Orbital launch vehicles, including operational interceptor weapon

systems. This provides another element of maturity and reliability. Moreover, it provides a direct conduit of the responsive launch requirements of an interceptor weapon system to be applied to responsive space lift for the Minotaur systems.

The combination of the cost effectiveness of utilizing the surplus PK boosters along with the performance they deliver also provides a launch cost per pound that is competitive with much larger and/or less proven launch vehicles. The performance capabilities and low cost have also given rise to interest in using a derivative of the PK SLV as a means of launching small satellites into high energy orbits. Preliminary designs for this system add a fifth stage and better optimize the vehicle design to deliver spacecraft to Geosynchronous Transfer Orbits (GTO) or other high energy trajectories. This launch vehicle

has been dubbed “Minotaur V”. However, it is currently conceptual and has not officially been made part of the OSP-2 contract.

The full Minotaur family of launch vehicle are capable of operations from any of the four commercial Spaceports (Alaska, California, Florida, and Virginia), as well as from existing U.S. Government facilities at Vandenberg Air Force Base (VAFB) in California and Kennedy Space Center in Florida. This is facilitated by the use of portable support equipment and minimal infrastructure requirements, as was demonstrated on the predecessor Taurus and Minotaur programs.

VEHICLE DESCRIPTION – MINOTAUR IV

The baseline Minotaur IV vehicle, shown in expanded view in Figure 2, is a four-stage, inertially guided, all solid propellant ground launched vehicle. Conservative design margins, state-of-the-art structural systems, a modular avionics architecture, and simplified integration and test capability yield a

robust, highly reliable launch vehicle design. Since the contract was originally awarded in early 2003, the Air Force has funded several early study and risk reduction efforts to lower the developmental risk to the first launch service customers, which will be discussed more specifically in the sections that follow.

Propulsion

The core boosters of the Minotaur IV vehicle are all solid rocket motors with extensive flight histories. The first three stages consist of the refurbished Government Furnished Equipment (GFE) Peacekeeper Stages 1, 2 and 3, which have a history of 50 launches under the Peacekeeper program, as well as three Taurus launches that used the PK Stage 1 as their initial stage. There have also been at least 18 static fire tests on each of the PK stages. For Minotaur IV, these booster assemblies are used as provided by the Government, requiring no modification or additional components. .

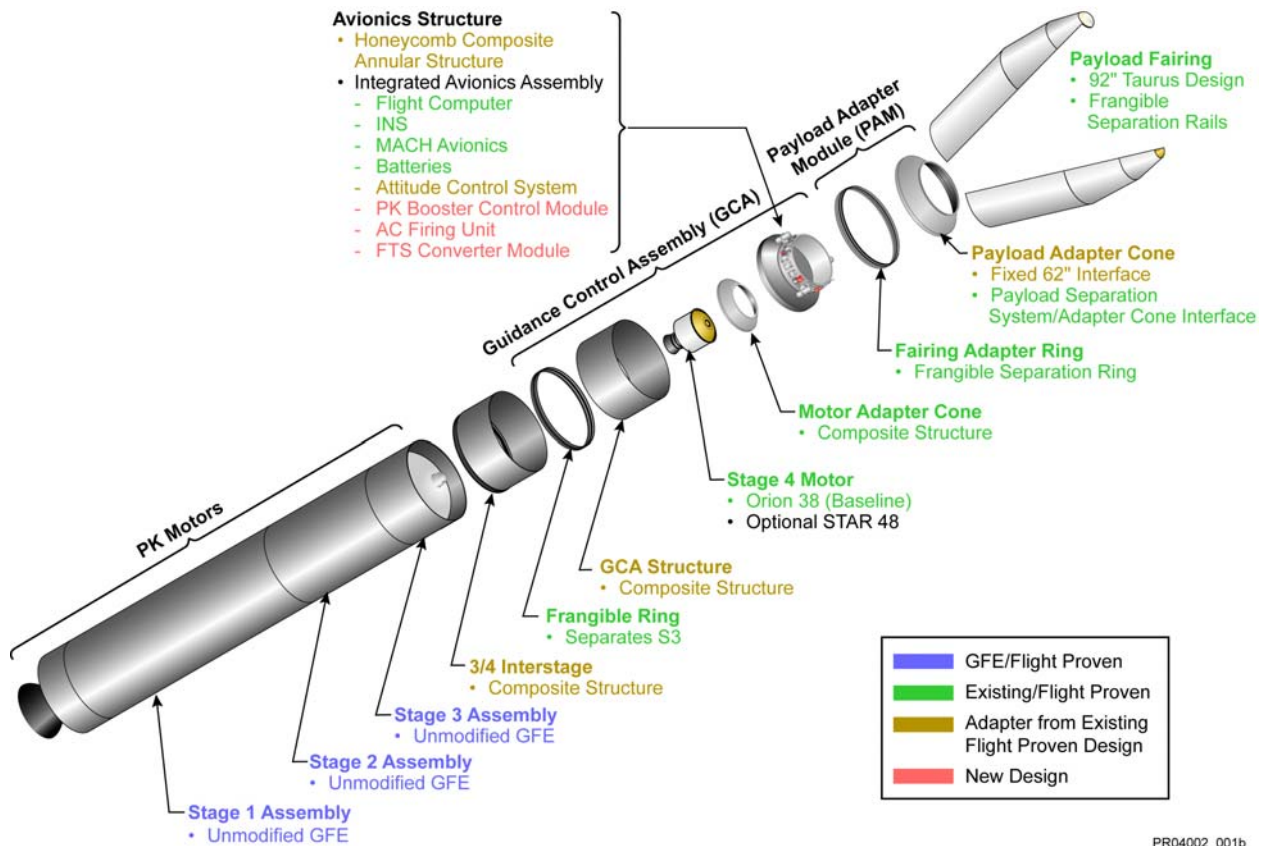

Figure 2 – Minotaur IV Configuration

To control the PK boosters, a PK Booster Control Module (PBCM), is being developed by Orbital. This unit is based on Orbital's Module Avionics Component Hardware (MACH) technology. A virtually identical module designed to control Minuteman boosters for the Minuteman-based OSP-2 vehicles is currently undergoing development and qualification testing at Orbital.

The Stage 4 motor is the ATK-built Orion 38 used on Orbital's Pegasus, Taurus, and Minotaur SLV's, as well as on the GMD OBV. The Orion 38 motor provides the velocity needed for orbit insertion, in the same functional manner as it is used on the predecessor vehicles. The Orion 38 features state-of-the-art design and materials with a successful flight heritage and is currently in production, actively flying payloads into space, with over 40 flawless flights to date and one static test.

Avionics

The basic avionics system design is shared across all OSP-2 vehicles, including the Minotaur I and Minotaur IV. It incorporates Orbital's "common hardware" critical components that are standardized across most of Orbital's launch vehicles, including the flight computer and Honeywell-built Space Integrated GPS Inertial Navigation System (SIGI). The OSP avionics architecture also makes extensive use of Orbital's, flight-proven Modular Avionics Control Hardware (MACH). Modular, function-specific modules are combined in stacks to meet vehicle-specific requirements. The functional modules from which the MACH stacks are created include power transfer, ordnance initiation, booster interface, communication, and telemetry processing. Orbital has designed, tested, and flown a variety of MACH modules, which provide an array of functional capability and flexibility. MACH has exhibited 100% reliability on all flights to date. For the PK-based vehicles, only three new avionics modules are being developed specifically to interface with the GFE PK subsystems. One of these, the PBCM was discussed above. The other two are 1) an AC Firing module to provide current to the GFE PK ordnance system and 2) an Inverter Module that inverts the signal from the command destruct receiver to drive the GFE PK Flight Termination Ordnance System (FTOS). These components are also based on the MACH architecture, providing a low risk development path.

Attitude Control System

The PK-SLV Attitude Control System (ACS) provides three-axis attitude control throughout boosted flight and coast phases. Stages 1, 2 and 3 utilize the PK

Thrust Vector Control (TVC) systems, using the PBCM to transfer the flight computer actuator commands to the individual Thrust Vector Actuators (TVAs). Stage 4 utilizes the same TVC system used by the Pegasus, Taurus and Minotaur vehicles which combines single-nozzle electromechanical TVC for pitch and yaw control with a three-axis, cold-gas attitude control system integrated in the avionics section providing roll control.

Modular Structure

The Guidance and Control Assembly (GCA) structures that house the avionics and stage 4 motors and provide the structural support for the payload, are common between the Minotaur IV SLV and the suborbital Target Vehicle (TV) configuration of the OSP-2 launch vehicles. They are made of graphite epoxy with aluminum honeycomb core construction. The preliminary design of these structures has been part of early risk mitigation efforts funded by the Air Force. They share design heritage with similar Taurus structures, but are also incorporating lessons learned from the Taurus experience. The structure is designed with a central cylinder on to which the avionics are integrated. The Stage 4 booster is mounted internal to this structure. This allows flexibility in the use of the central volume to house the baseline Orion 38 or a liquid booster system for the TV application, as well as growth options employing other boosters such as a Star 48.

Payload Fairing and Attach Cone

The payload fairing and attach cone are designed to integrate with the spacecraft independent from the rest of the booster stack. This is similar to the approach used on Taurus, which is also the source of the fairing design. The 92" fairing used for the Minotaur IV was developed and demonstrated on two Taurus launches. The adapter structure incorporates a payload attach cone to which the spacecraft is integrated and a dedicated MACH avionics assembly for the electrical payload interface. Using a dedicated MACH assembly will allow test and verification of the LV-to-spacecraft electrical interface in flight configuration prior to release to the pad. After integration and test of the spacecraft-fairing assembly, it will be transported vertically to the pad and emplaced with a crane lift on top of the rest of the integrated launch vehicle stack. This allows parallel processing of both the LV and the spacecraft, streamlining the prelaunch timeline.

PERFORMANCE

A key feature of the Minotaur family of vehicles is the performance to orbit they can deliver at a relatively low cost. In particular, the PK-based Minotaur IV is among

the lowest cost launch vehicles available in terms of cost per pound to low earth orbit. With a payload capacity of 3826 lbm (1735 kg) to the benchmark 28.5 deg, 100 nm (185 km) orbit and an all encompassing launch service cost of around \$20M, the resulting cost per pound is in the neighborhood of \$5000/lbm (<\$11,000/kg). As a total fly-away cost, this value includes all elements necessary to facilitate a launch, including range costs, government oversight, GFE booster refurbishment, and independent mission assurance efforts, not just the base launch vehicle cost. This allows the launch of small to medium size spacecraft at costs per pound that have typically only been available on much larger domestic launch vehicles and/or foreign launch vehicles.

The overall performance to orbit of the baseline Minotaur IV vehicle is summarized in Figure 3. Care has been taken to hold-back adequate developmental margin so that these values will ultimately achieved when the system development is completed. Further confidence in the predicted performance comes from using well-characterized motors with extensive flight histories.

West Coast Launches

For missions requiring high inclination orbits (greater

than 60°), launches can be conducted from facilities at VAFB or Kodiak Island, AK. Both facilities can accommodate inclinations from 60° to 120°, although inclinations below 72° from VAFB would require an out-of-plane dogleg, thereby reducing payload capability. As with the initial OSP Minotaur missions, the Minotaur IV can be launched from Space Launch Complex 8 (SLC-8) on South VAFB, the California Spaceport facility operated by Spaceport Systems International (SSI). The launch facility at Kodiak Island, operated by the Alaska Aerospace Development Corporation (AADC) has been used for both orbital and suborbital launches. 400 nm, sun synchronous orbit), launched from VAFB, the Minotaur IV performance is greater than 2200 lbm (1000 kg), as shown in Figure 3. Performance from Kodiak Island will be similar.

East Coast Launches

For easterly launch azimuths to achieve orbital inclinations between 28.5° and 60°, Minotaur IV can be launched from facilities at Cape Canaveral Air Force Station (CCAFS), FL or NASA’s Wallops Flight Facility (WFF) in VA. Launches from Florida will notionally use the launch facilities at LC-46 for

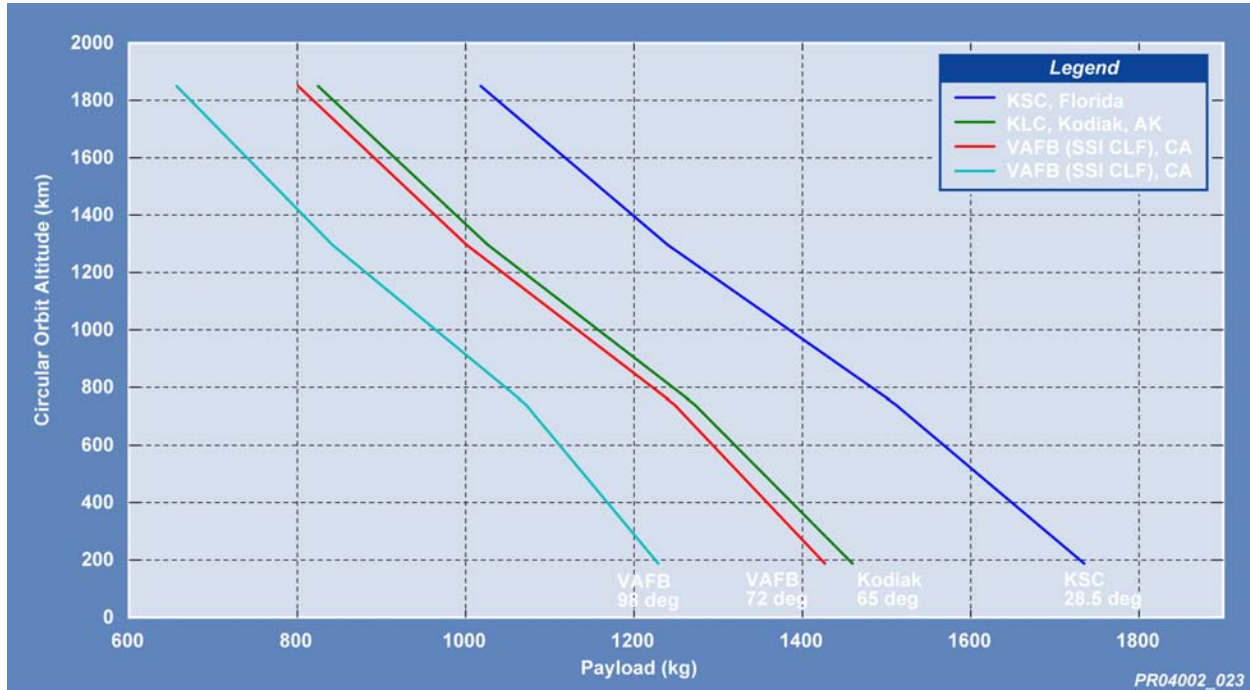

Figure 3 – Minotaur IV Performance to Orbit

inclinations from 28.5° to 40°. Inclinations above 35° may have reduced performance due to the need for a trajectory dogleg. .

As mentioned previously for the benchmark Low Earth Orbit (LEO) of 100 nm altitude and 28.5 deg inclination, the PK SLV has performance 3826 lbm (1735 kg). The Virginia Space Flight Center facilities at the WFF may be used for inclinations from 30° to 60°. Southeasterly launches from WFF offer fewer over flight concerns than Florida. Inclinations below 35° and above 55° are feasible, albeit with doglegs and altitude constraints due to stage impact considerations.

HIGH ENERGY CONFIGURATION

To provide a capability to GTO and beyond, a five stage PK-based vehicle has been conceived. This is the result of growing interest in delivering small spacecraft into high-energy trajectories, such as GEO or trans-lunar. A preliminary design study was conducted to identify candidate configurations derived from the baseline Minotaur IV design, focusing on using existing rocket motors. These are potential growth configurations of the Minotaur IV, but are not currently

part of the OSP-2 contract. One of these configurations is shown in Figure 4, utilizing an Orion 50XL as the Stage 4 motor and an Orion 38 as the Stage 5 insertion motor. These are the same motors used as the upper two stages on the baseline Minotaur, Pegasus, and Taurus vehicles. Although not shown in the figure, the lower stages are the same as the baseline vehicle.

Because the GCA structure is designed to accommodate different motor configurations, the use of a different Stage 4 motor is a straight forward adaptation. A similar, albeit smaller, composite structure is used to accommodate the Stage 5 motor assembly. However, the avionics components are split between Stage 4 and 5 to minimize the mass carried on Stage 5, thereby maximizing the payload mass capability. Because the motors are common with Minotaur I, Pegasus, and Taurus, this is the lowest risk configuration since they are well characterized, understood, and are currently in ongoing production at ATK. There is, however, a trade-off in performance as

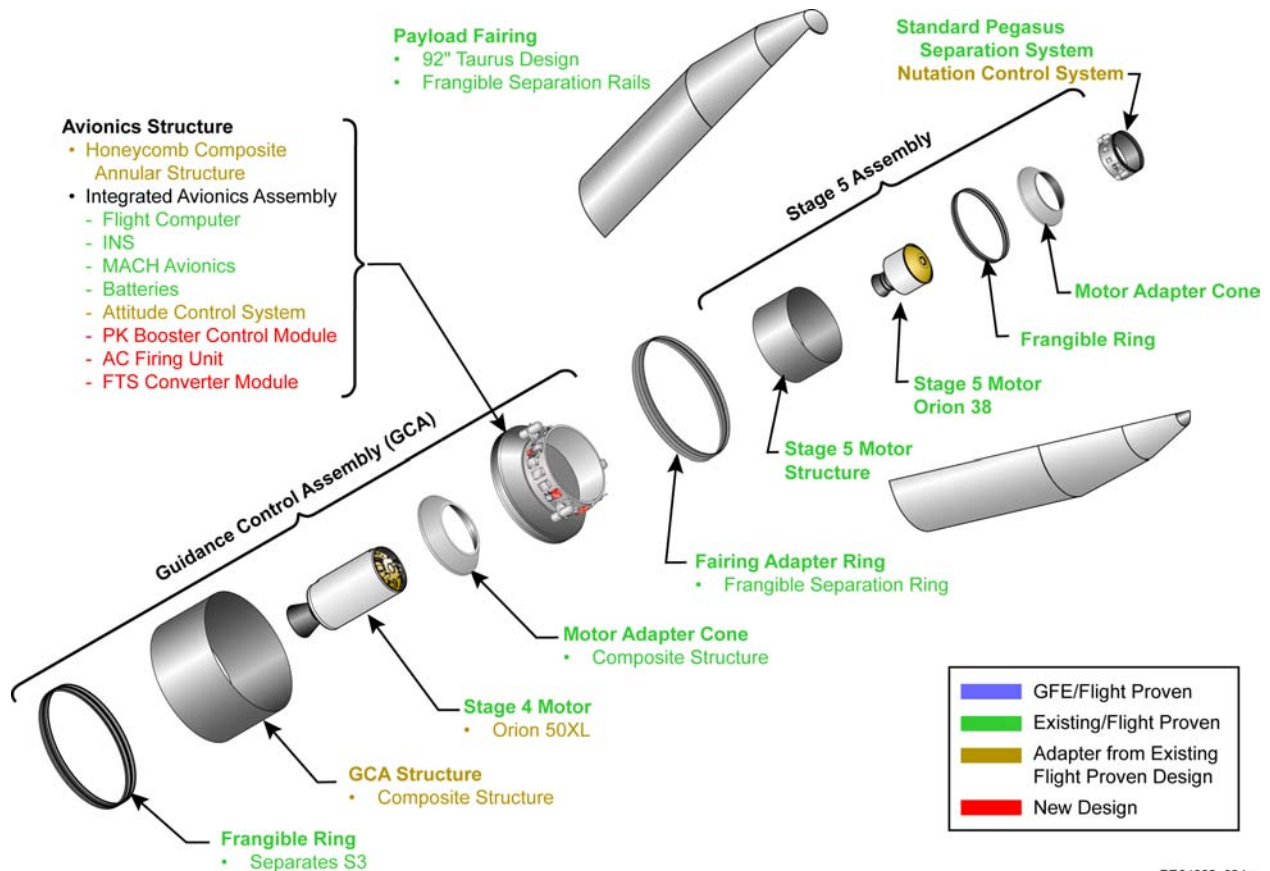

PR04002_024a

Figure 4 – Minotaur V Front End Orion 50XL/Orion 38 Configuration

they are not as well optimized as the other candidate motors for the GTO application.

Other configurations are also conceived that have higher performance, albeit also with a corresponding increase in developmental risk and costs. One configuration replaces the Orion 38 stage with a Star 37GV. This motor retains the 3-axis control of the Orion-38 configuration and provides higher impulse. Another configuration substitutes a Star 48 motor for 4th stage Orion 50XL. The most payload mass to GTO was obtained by using a spinning Star 37FM 5th stage and, therefore, not needing to carry GNC avionics or attitude control on the Stage 5 assembly.

Performance to GTO

For the GTO configuration discussed previously performance predictions were based on launching from LV-46 at the Cape Canaveral Air Force Station (CCAFS). The performance predictions that have been developed are based a direct ascent, non-apsidal insertion into an optimized elliptical intermediate orbit prior to Stage 5 burn to deliver the spacecraft into GTO.

For the illustrated Orion 50XL/Orion 38 configuration, the payload delivered to GTO is 1095 lbm (497 kg). This configuration provides 3-axis control of the Stage 5, thereby supporting spacecraft that do not need nor desire to be spin stabilized. Replacing the 4th stage Orion 50XL with a Star 48V gives an increase in performance to 1199 lbm (544 kg). Performance of 1219 lbm (553 kg) can be obtained by retaining the Orion 50XL 4th Stage, but substituting a Star 37GV for the Orion 38 Stage 5. The combination of the Star 48V 4th stage and Star 37GV 5th stage gives performance of 1355 lbm (614 kg). Maximum performance can be achieved by eliminating the 3-axis control capability of the above configurations in favor of a spin-stabilized Stage 5. The combination of a Star 48GV Stage 4 and a spin-stabilized Star 37FM gives up to 1634 lbm (741 kg) to GTO. As will the baseline performance, these have been predicted using conservative assumptions to assure that the full indicated mass will be available come launch day.

Performance for Lunar Missions

Once the ability to reach high-energy GTO orbits has been achieved, it is a relatively small step to move on to trans-lunar trajectories. With the new Space Exploration Initiative, this is an area gaining increased attention. As an example, the Star 48V/Star 37FM (spinning) configuration can deliver between 1140 lbm (517 kg) and 910 lbm (413 kg) to the moon, depending on the inclination of the moon relative to the equator at

launch. The highest performance is when the moon is 28 deg inclined and therefore an orbital inclination change is not required.

PAYLOAD ACCOMMODATIONS

Following the lead of the original Minotaur, the Minotaur IV is designed to flexibly accommodate a variety of spacecraft mission requirements. As mentioned previously, the payload fairing and attach structure are designed to allow modular integration separate from the rest of the launch vehicle. A dedicated payload-interface MACH avionics assembly allows full command and control interface testing between the LV and spacecraft during payload integration, prior to committing the integrated spacecraft/fairing assembly to the launch pad. This also facilitates the growing interest in responsive launch operations, allowing the spacecraft to be fully integrated independently of the LV and then brought together with minimal final test and checkout. Providing a number of options enhances the baseline capabilities, as well as maintaining the willingness to coordinate additional mission-specific options with individual spacecraft organizations. An updated summary of the payload accommodations follows below.

Standard Payload Accommodations

The baseline payload accommodations have been designed to support the greatest number of spacecraft designs and missions. Standardized designs for the mechanical and electrical interfaces have been defined to aid spacecraft designers in initial mission planning.

Mechanical Interface

The standard mechanical interface between the spacecraft and launch vehicle used the Evolved Expendable Launch Vehicle (EELV)-standard 62-inch bolt pattern (Figure 5). This interface is contained within the Taurus-derived 92 inch fairing, giving the spacecraft dynamic envelope shown in Figure 6. To accommodate smaller diameter interfaces, such as typical 37 in, 38 in., or 47 in. separation system sizes, adapter cones will be developed. The height of these adapter cones will have to be accounted for within the payload envelope shown.

Electrical Interface

The payload electrical interface supports battery charging, external power, discrete commands, discrete telemetry, analog telemetry, serial communication, payload separation indications, and up to 16 separate ordnance discrettes. All of the command, control, and telemetry communications between the spacecraft and

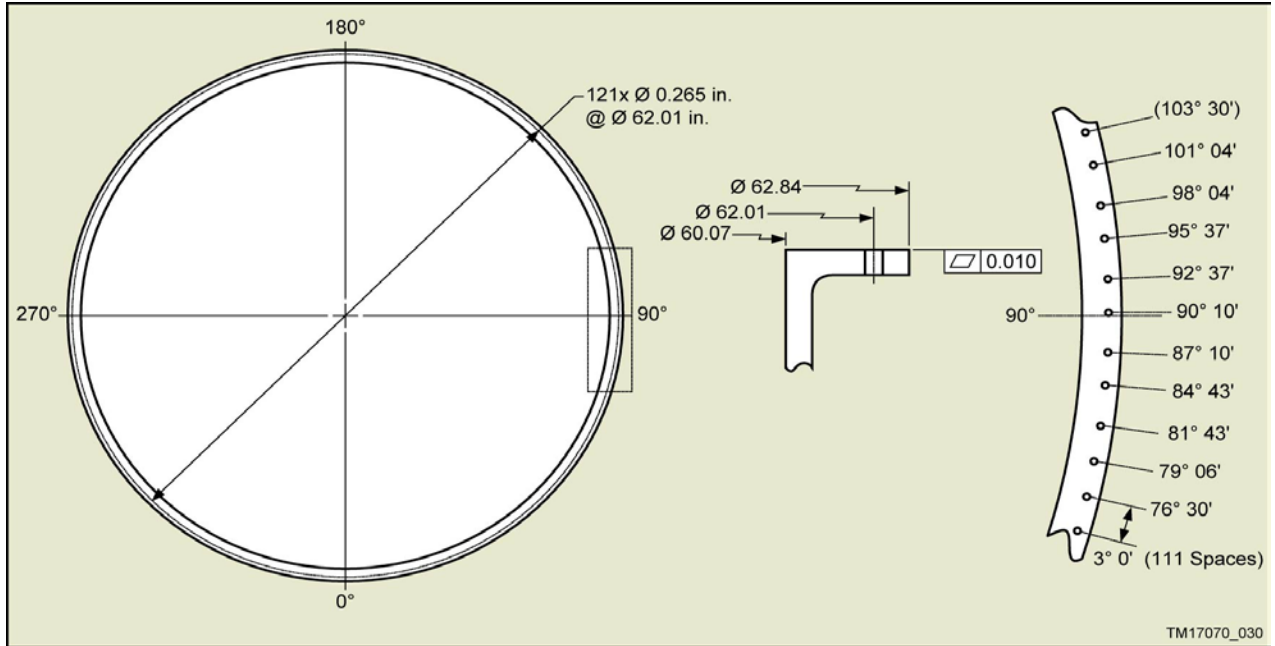

Figure 5 - Minotaur IV Standard Fixed Payload Interface

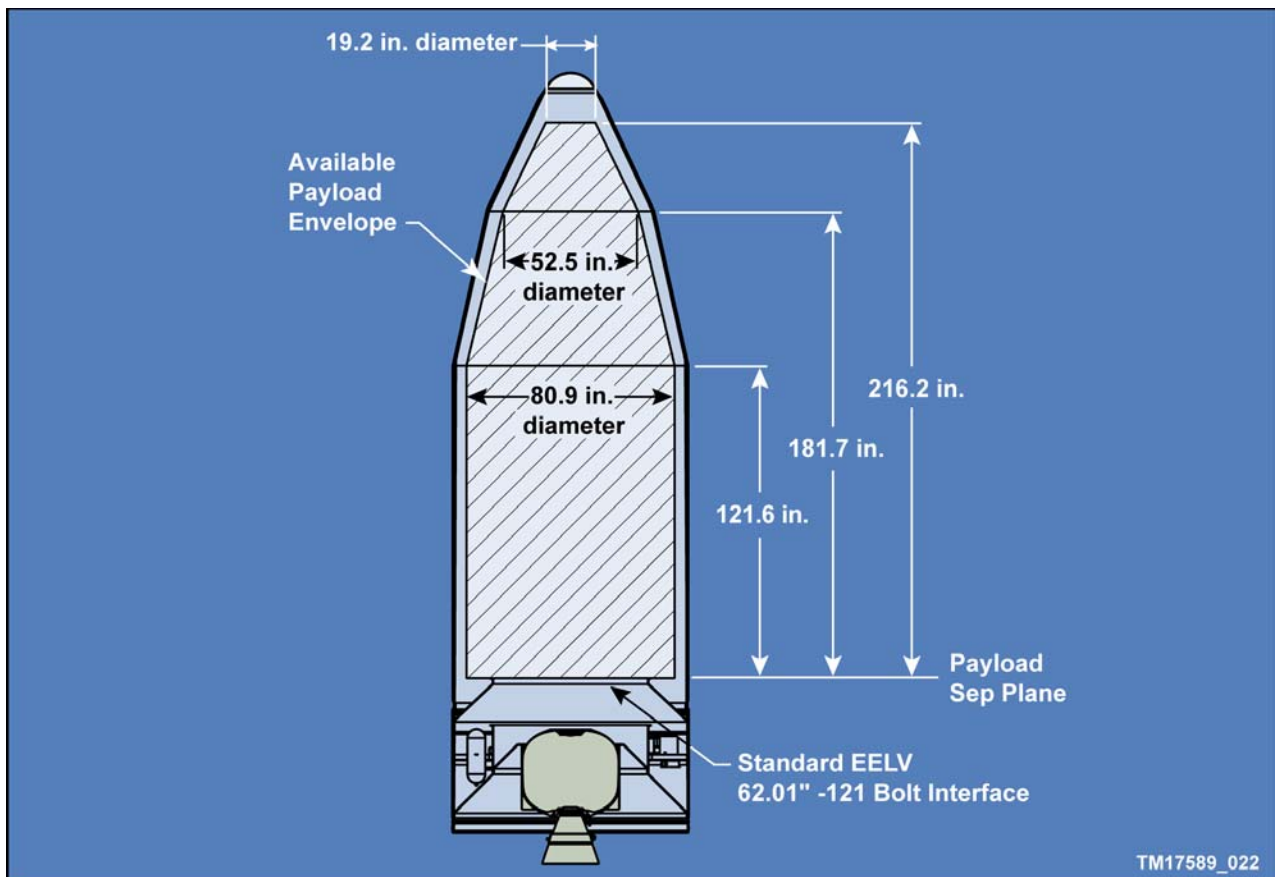

Figure 6 – Minotaur IV Standard Payload Dynamic Envelope

LV will be accommodated by the dedicated MACH avionics box.

In addition to the LV-to-spacecraft communications, a dedicated payload ground umbilical is provided as a direct pass-through payload interface for use in ground testing and pre-launch operations. The Payload umbilical interface consists of at least 24 circuits (48 copper lines) that will be provided via a dedicated payload umbilical within the vehicle to allow the payload ground control command, control, monitor, and power to be easily configured for user requirements. The cable interface between the Payload Front Section umbilical and Payload bulkhead interface will be tailored to different connectors to match payload cabling requirements. The payload electrical interface and associated GSE interface requirements are documented in a mission specific ICD.

Environments

As an important part of the early PK-based vehicle development effort, preliminary payload environments are being developed and refined for the Minotaur IV. The structural design of the GCA is a key factor in determining dynamic environments, such as shock and vibration. Since this design is still being optimized, the final best estimated environments are not yet able to be completed. However, the preliminary estimates developed initially for the OSP-2 proposal are still valid in that they either envelope the predictions seen to date or are being used to drive the structural design.

These preliminary environmental design and test criteria have been derived using measured data obtained from previous PK, Pegasus, Taurus and Minotaur missions, motor static fire tests, other system development tests and analyses. The predicted levels presented are intended to be representative of mission specific levels. Mission specific analyses will also be performed as a standard service and documented in the mission ICD. The scope of the present document does not allow presentation of great detail regarding the environment, but the levels predicted are within those typically seen for existing launch vehicles. Preliminary characteristic values are shown in Figure 7.

Non-Standard Options

The OSP-2 launch service is structured to provide a baseline vehicle configuration that is then augmented with optional enhancements to meet the unique needs of individual payloads. The baseline vehicle capabilities have been summarized in the previous sections and the optional enhanced capabilities are defined below. The enhanced options allow customization of launch support and accommodations

the PK vehicle designs on an efficient, “as needed” basis. Some of most relevant of these options are discussed below.

Environment	Characteristic Level (Preliminary)
Random Vibration	9.0 g RMS (Best Estimated) 12.9 g-RMS (Worst Case Upper Bound)
Sine Vibration	1.6 g (variable between 45 and 75 Hz)
Shock Sep System Non-Separating	3,500 g 3,000 g
Acoustic	138 dB-OASPL
Acceleration (Steady-State)	9 g's (2,000 lbm payload)

Figure 7 Minotaur IV Characteristic Payload Environments (Preliminary)

Separation Systems

Various separation systems can be provided or accommodated to meet mission-unique requirements. As a typical option, the Minotaur IV provides a payload separation system that is flight proven on Taurus. SAAB Ericson Space (SES) manufactures the separation system for Orbital. This system is based on a design that has flown over 30 times with 100% success.

Payload Isolation System

OSP offers a flight-proven payload isolation system as a non-standard service. The Air Force Research Laboratory (AFRL) and CSA Engineering developed the Softride for Small Satellites (SRSS). It was successfully demonstrated on the two initial OSP Minotaur missions and five Taurus missions. This passive, mechanical isolation system has demonstrated the capability to significantly alleviate the transient dynamic loads that occur during flight - typically transient loads are reduced to approximately 50% of the level they would be without the system. However, the exact results can be expected to vary for each particular spacecraft and with location on the spacecraft. The isolation system does impact overall vehicle performance and the available payload dynamic envelope. The specific values for the Minotaur IV application have not been determined, pending the development of an isolators system specifically for this application.

Enhanced Insertion Accuracy

Insertion accuracy greater than standard or support for multiple payload insertion can be provided as an enhanced option utilizing the Hydrazine Auxiliary Propulsion Stage (HAPS) developed and flown on Orbital’s Pegasus. HAPS is integrated inside the avionics structure and consists of a monopropellant hydrazine propulsion subsystem and a separation subsystem. After burn-out and separation from the Stage 4 motor, the HAPS hydrazine thrusters provide additional velocity for both improved performance and precise orbit insertion. Six-DOF analyses, as well as Pegasus experience, show that the HAPS system provides a controlled impulse to achieve insertion accuracies of less than 10 nm (3-σ) and inclinations of less than 0.05 deg (3-σ).

Alternate Stage 4 Motors

The modular design of Orbital’s GCA and integrating structures provides great flexibility in accommodating alternative Stage 4 propulsion systems. As one low risk example, an optional configuration using an ATK Thiokol Star-48 motor has been conceived. This option provides approximately 500 lbm greater throw-weight-to-orbit capability to 100 nm, 28.5 degree circular orbit relative to the baseline Orion 38 design. The only modifications required to accommodate this change are a modified Motor Adapter Cone (MAC) with the Star 48 forward interface and a longer 3/4

interstage to allow room for the increased motor length. This modularity also accommodates the growth options to the five stage, high-energy configurations discussed earlier.

Environmental Control Options

Several options to provide enhanced environmental control to the payload are available with the PK SLV. These include the ability to deliver conditioned air, clean nitrogen purge, and enhanced encapsulation cleanliness. The enhanced cleanliness is available with Class 100,000 or Class 10,000 air quality and fairing interior surface cleanliness at “Visibly Clean”, Levels 1 or 2.

LAUNCH OPERATIONS

Much of the Taurus and Minotaur ground processing and launch operations are also employed, providing many proven processes and unique knowledge base. The system uses the same flat pad, stool launch approach as Taurus and the same portable electrical ground support equipment (GSE) used on Minotaur – and all other OSP vehicles – to be readily adaptable to multiple potential launch sites. The payload is modularly encapsulated in a manner similar to Taurus, allowing vertical integration and parallel processing of the spacecraft and launch vehicle in separate facilities. The final field processing flow, including final LV-to-spacecraft integration, is shown in Figure 8.

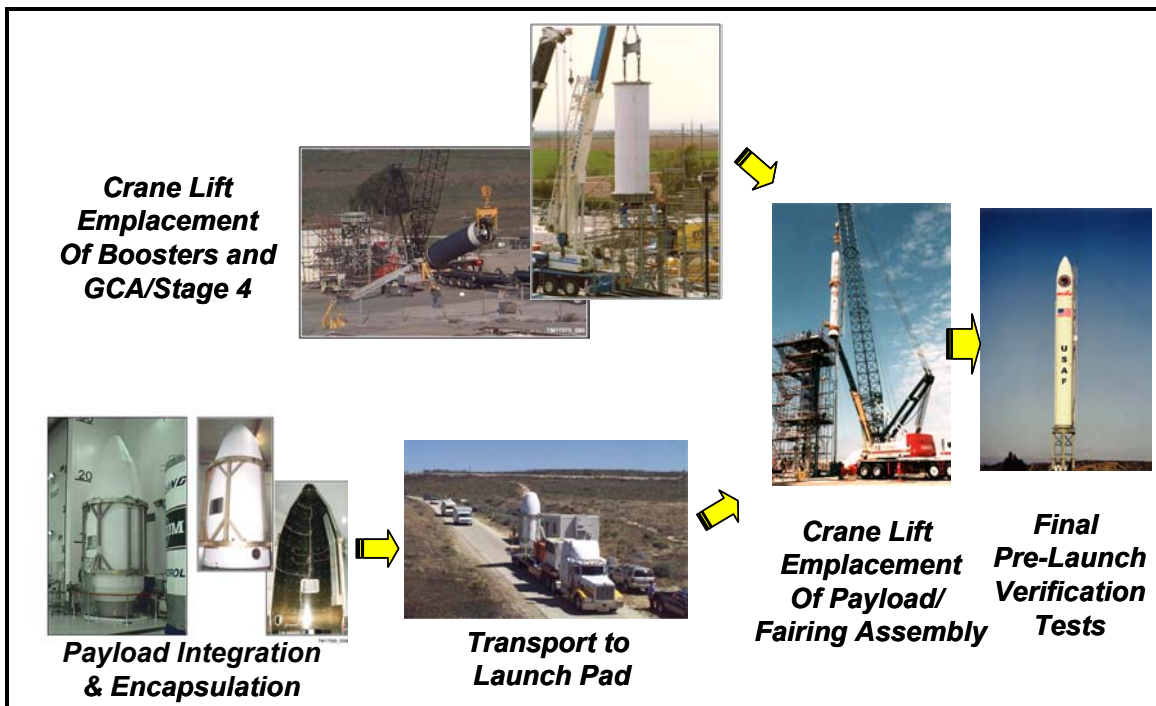

Figure 8 Minotaur IV Launch Site Processing

As mentioned previously, the Minotaur family of launch vehicles is designed to be launched from facilities at multiple launch sites requiring minimal specialized infrastructure. These launch sites are nominally the four commercial spaceport facilities at Vandenberg AFB, CA, Wallops Flight Facility, VA, Cape Canaveral Air Force Station, FL, and Kodiak Island, AK. All four facilities either currently have or are constructing launch gantry structures that can accommodate the Minotaur family of launch vehicles, including the Minotaur IV.

SUMMARY

Development of the PK-based SLV, dubbed Minotaur IV, is well under way. The initial missions have been manifested with a first launch planned in 2007. Although the Minotaur IV is considered a new launch vehicle, it is composed of elements that have extensive flight histories, providing a relatively low risk development effort. Moreover, the performance potential and low cost of the PK-based configuration has given rise to a growth option to deliver small spacecraft to high energy orbits, such as GTO or translunar trajectories.