

The New Mexico State University Satellite (*NMSUSat*) Mission

Stephen Horan, S. Stochaj, L. Alvarez W. Ege, V. Romero, F. Zamarron,
C. Boehmer, J. Cecil, J. Clark, G. Guyer, E. Johnson, S. Ranade, and L. Riley

Klipsch School of Electrical and Computer Engineering
New Mexico State University
Box 30001, MSC 3-O
Las Cruces, NM 88003-8001
ph: 505-646-4856; e-mail: shoran@nmsu.edu

Abstract. The New Mexico State University Satellite (*NMSUSat*) is part of the University Nanosat 3 program managed by the Air Force Research Laboratory and it is being developed at New Mexico State University. The planned Science Mission for the satellite is to perform Near Ultra Violet emission intensity measurements of the earth's upper atmosphere over the night side of the earth. The Engineering Mission is to demonstrate techniques for distributed data relaying over the Internet and to conduct an energy storage experiment to assess the operational characteristics of double layer capacitors. The Educational Mission of the program to assist in the further development of the aerospace engineering concentration area in the College of Engineering and to develop multi-disciplinary capstone and design classes for students in engineering departments, computer science, and the engineering physics program. This paper will discuss the preliminary design for the satellite components and how the mission segments will be worked among the participating departments at New Mexico State University.

Introduction

The students, faculty, and staff from the College of Engineering and the College of Arts and Sciences are developing a nanosatellite at New Mexico State University (NMSU) to be called the *NMSUSat* as part of the University Nanosatellite 3 Program managed by the Air Force Research Laboratory. This satellite will be developed based on the heritage of the current 3 Corner Satellite (3CS) mission [1] and the existing engineering and science capabilities present on campus. The development of an entire satellite at NMSU will enhance the educational and technical capabilities in the academic departments at NMSU.

In this paper, we will look at the science, engineering, and education missions for the *NMSUSat* and the overall design concept for the satellite components. The details of the design components will be developed over the next two academic years as the design classes proceed to the completion of the project.

Mission Areas

The mission objectives for the *NMSUSat* program will cover three areas: science, technology development, and educational development. The *NMSUSat* mission objectives are as follows:

1. The scientific objective for the *NMSUSat* mission is to perform Near Ultra Violet (NUV) emission intensity measurements of the earth's upper atmosphere over the night side of the earth.
2. The engineering objectives for the *NMSUSat* mission are to conduct two types of experiments with the nanosat: communications and energy storage. The communications experiment is to demonstrate techniques for distributed data relaying over the Internet to support autonomous satellite operations. The energy storage experiment is to assess the operational characteristics of double layer capacitors as compared with batteries for electrical energy storage if these devices can be made space rated.
3. The educational objectives for the *NMSUSat* mission are to assist in the further development of the aerospace engineering concentration area in the College of Engineering and to develop multi-disciplinary capstone and design classes for students in engineering departments and the engineering physics program.

In the following paragraphs, we look at the details of the mission areas.

Science Mission

The experiment for the science component of the *NMSUSat* mission is the acquisition of NUV emission intensity measurements over the night side of the earth. Over the orbiting mission duration, the satellite will construct a map of the measurements as a function of time and location. If the satellite stays on orbit long enough, variations in these measurements may be determined.

NASA is currently studying a mission to measure the composition, energy spectrum, and arrival direction of super-GZK (Griesen-Zatsepin-Kuzmin) cosmic rays for determining the origin of these particles and the means by which they achieve their energy. The Orbiting Wide-angle Light collectors (OWL) will image the fluorescence glow of atmospheric nitrogen caused by cosmic ray air showers. OWL is part of NASA's 2000 Strategic Plan and the Cosmic Journeys initiative. The *NMSUSat* team will develop a small instrument to monitor the NUV albedo from the earth. The albedo has several sources: the resonance fluorescent glow (nightglow), starlight and moonlight scattered by air molecules and aerosol particles, multiply-scattered sunlight from the rising and setting sun, and manmade light sources. This light constitutes a background for OWL. By correlating the position of our satellite with images from weather service satellites, we also can determine the dependence of the NUV background on different types and amounts of cloud cover. This relationship is important for the determination of the aperture of the OWL instrument.

Nightglow has rarely been measured. The first measurements date back to J. P. Hennes [2] and Lebedinsky [3]. Hennes flew an Aerobee rocket, which made a 260 second exposure on film that was sensitive in this regime. Lebedinsky flew a camera on-board a COSMOS 45 satellite. In the mid-1980s, R.G.H. Greer et al. [4], flew a series of PETREL rockets that looked at the nightglow for a combined exposure of 2.5 hours. These flights produced a series of profiles that show the altitude dependence of the emission profile. These profiles show that the emission peaks at an altitude of ~ 95 km. From Hennes' data we determined that the NUV background light level is ~ 400 Rayleighs ($1 \text{ Rayleigh} = 10^6/4 \text{ photons-cm}^{-2}\text{sec}^{-1}\text{-sr}^{-1}$). Over

the wavelength range of interest to OWL, 330 - 400 nm, this translates to ~ 320 photons- m^{-2} - sr^{-1} - $nsec^{-1}$. The COSMOS instrument has about 5 hours worth of data from the mid-sixties. It measured a higher nightglow level of ~ 2000 photons- m^{-2} - sr^{-1} - $nsec^{-1}$, but over a large spectral band, 260 nm - 400 nm. Our instrument will extend the monitoring period from hours to tens of days. The nanosat NUV instrument will comprise a set of three, single photomultiplier tube cameras that will be readout via an ADC once every minute. The field of view of each camera will be limited by a pinhole-type stop. This configuration will allow the middle latitudes of the earth to be monitored over the lifetime of the satellite.

Engineering Mission

The engineering mission involves satellite communications and energy storage technology. The communications technology component of the *NMSUSat* mission will help in the development of IP-based communications architectures for space and in autonomous operations. When the *NMSUSat* is in view of the ground station, the planned wireless networking techniques will allow the *NMSUSat* to act as a network node in space and utilize IP-based techniques between the mission elements to transfer command and telemetry files. Between ground station passes, we plan to use the existing amateur radio Automatic Position Reporting System (APRS) to demonstrate how autonomous data recovery may be accomplished. This will emulate how components of sensor webs may operate in the future where data is relayed to the ground and automatically returned to a central collection location for processing and analysis

The energy storage experiment is intended to assess new ways of energy storage. It is the

expectation of the designers that the double layer capacitor technology will have few problems in space operations than traditional battery technology. If these devices can be space rated, then an experiment to test this hypothesis will assist in technology verification.

Education Mission

The educational component of the overall mission will assist NMSU in its long-range strategic development of aerospace capabilities. Recently, "space" was named as a strategic development area for NMSU as a whole. This program will specifically assist in developing the aerospace-related educational component of the overall university strategic direction. The *NMSUSat* project is seen as a focal point for students in engineering and science across two colleges at NMSU.

Outreach

In addition to the students involved with the classroom development, students outside this venue will also be involved. In particular, NMSU administers programs such as *Upward Bound* where students making the transition from high school to the university are brought in to work with faculty and students on projects. The *NMSUSat* design has already been used in this program during summer 2003 and is planned for 2004 as well. The College of Engineering provides programs such as PREP to introduce middle-school and high-school students to university activities. The *NMSUSat* will be used as an example of science and engineering activity for these students.

The use of the APRS network for data relay is also a form of outreach. We will have a number of amateur radio operators collecting data and

relaying that back to NMSU. While the initial goal is to have improved telemetry acquisition, the process will be of interest to the amateur satellite community as well. The communications system will be designed to allow interested amateurs to use *NMSUSat* as a digital repeater.

Major Subsystems

A nanosatellite will be designed to provide the operational support to carry out the science, technology, and educational mission elements. This satellite will be designed to fit the nominal design envelope [5] of a mass not exceed 25 kg and linear dimensions not to exceed 47.5 cm at the widest point. The design will be carried out to the Engineering Design Unit (EDU) level. The conceptual design for the nanosatellite is given in Figure 1. The left-hand side of the figure shows the bottom view of the satellite structure which permits a mechanical interface

with the Nanosatellite Separation System (NSS). The right-hand side of the figure shows the side view of the satellite (nadir towards the top) which does not exceed the maximum height of 47.5 cm.

The major satellite subsystems are summarized in the following paragraphs.

Science Instrument Development

The science instrument measures the NUV emission intensity from the upper atmosphere. The science instrument provides this measurement using three phototubes for the intensity measurement. The phototubes are arranged with one pointing at nadir and two pointing off from nadir to allow corrections to be applied to the measurements for variances in the orientation of *NMSUSat*. To conduct the measurements, the *NMSUSat* orientation will need to be maintained to within $\pm 5^\circ$ of exact

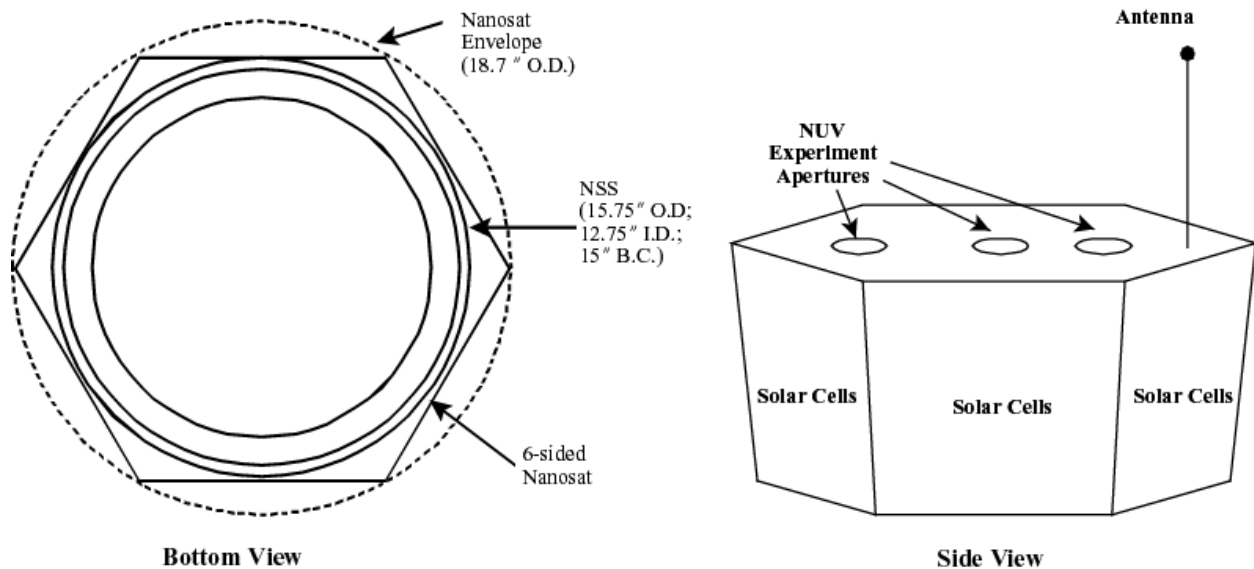

Figure 1 – Bottom and side view of the conceptual design for the *NMSUSat* structure.

nadir pointing along the roll and pitch axes. Yaw pointing control is unnecessary due to symmetry and the ability to correct for positioning in the analysis. The science instrument requires that the ancillary data (time and location) be appended to the intensity measurement for each phototube.

A secondary NUV detector is to be supplied by Los Alamos National Laboratory (LANL). This detector is being developed entirely at LANL and requires power and data services from *NMSUSat*. The preliminary design for the LANL instrument is to provide some, but not total, frequency band overlap with the NMSU design.

Both instrument sets are schematically illustrated in Figure 2.

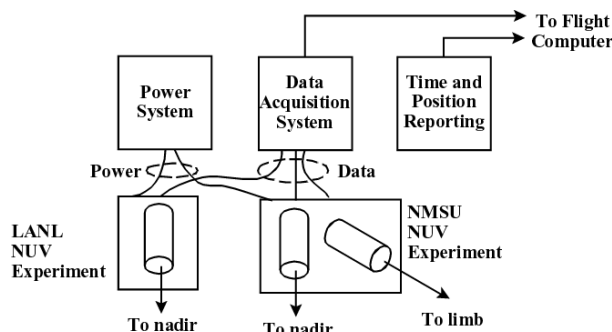

Figure 2 – Science experiment functional configuration.

Structure

The nanosatellite structure leverages off the design experience learned during the development of the 3CS structure. The envelope defining the structure was given in Figure 1. The baseline structure is based upon

1. using a hexagonal aluminum isogrid structure as the load-bearing element for the nanosatellite;

2. encasing nanosat subsystem elements, except solar cells and antennas, in aluminum boxes to allow for mounting onto the structure and to provide a safe enclosure for the subsystem; and
3. ensuring that the structure meets structural vibration and strength specifications.

This structure holds the elements together with most subsystem elements mounted internally. External mounting is supplied for the solar cells and antenna components. The structures team will also take the lead on thermal analysis of the satellite.

Power

The power subsystem provides power to the nanosatellite during both sunlight and eclipse conditions. Additionally, the power system is part of the overall satellite launch safety preparations through the inhibit electronics. The power system design will need to

1. design a solar cell system to charge the batteries and provide power during the sunlight portion of each orbit;
2. design a battery system to provide power during the eclipse portion of each orbit;
3. provide a voltage regulation system to supply the voltage levels required by the scientific instrument and the other subsystems; and
4. design the power inhibit system and inhibit verification system so that the satellite can be launched safely.

The inhibit electronics are required for launch safety to keep the *NMSUSat* from powering during launch. Part of the power subsystem development will be the assessment of the

potential for the use of double layer capacitors rather than batteries for storage. This is potentially new technology for small spacecraft and if the devices can be packaged appropriately for a shuttle launch, then an experiment will be designed to assess their operational characteristics in space. The functional block diagram for the power system is given in Figure 3.

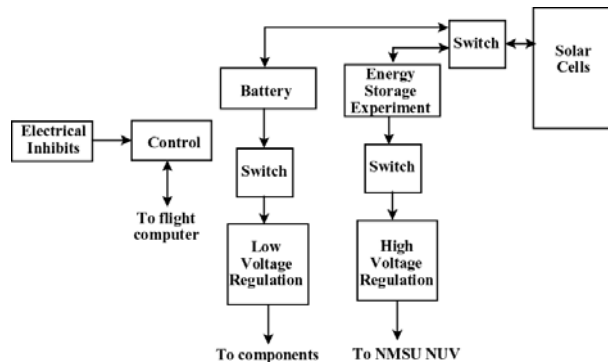

Figure 3 – Functional block diagram for the *NMSUSat* power system.

We plan to leverage off the 3CS inhibit, battery, and solar cell design as much as possible in developing the power system.

Attitude Control

The *NMSUSat* is oriented so that the photodetectors in the nanosatellite are pointed at the Earth for the measurement program. The measurements do not require full, three-axis satellite orientation. The attitude control system provides

1. a minimum of two-axis attitude control for the nanosatellite;
2. sensing and reporting solar direction relative to the nanosatellite;
3. sensing and reporting Earth direction relative to the nanosatellite; and
4. sensing and reporting the position of the

nanosatellite.

The design for the *NMSUSat* time and reporting system is to use a GPS receiver. The baseline design is to use an Orion-type design with the chip set from Zarlink. The earth sensor and sun sensor design leverage off designs for these components in the literature.

Communications

The *NMSUSat* requires two communications services: space telecommand service and space telemetry service. The baseline design is to use VHF/UHF radio technology for the space telecommand and space telemetering services based on the radio system used for the 3CS mission [6]. The communications system provides

1. space telecommand services when the *NMSUSat* is visible from the NMSU ground station equipment;
2. space telemetry services with two modes of telemetry downlink: direct downlink when *NMSUSat* is visible from NMSU and relayed downlink utilizing the world-wide amateur radio Automatic Position Reporting System (APRS) where received data is sent back to NMSU over the Internet;
3. APRS digipeater support for data relay; and
4. access to the *NMSUSat* for pre-flight checkout.

The communications team also provides the necessary antenna elements to accomplish the communications in each band. As part of the communications subsystem design, that team performs the frequency coordination with the relevant agencies for using these services.

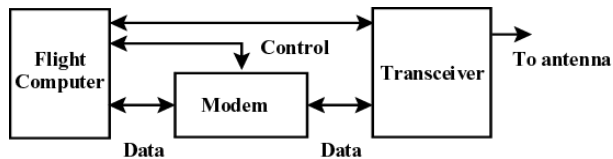

Figure 4 – Components of the baseline communications system for the *NMSUSat*.

Data Acquisition

The *NMSUSat* data acquisition system monitors the output of the science instrument and the satellite health and welfare sensors. The data acquisition system will need to

1. sense the health and welfare sensors and perform a pulse code modulation conversion for relay to the ground station using the space telemetry communications;
2. sense the experimental data and package that data for transmission via the space telemetry communications link;
3. provide an interface with the flight computer system for data collection and storage.

The baseline design for the data acquisition system utilizes the analog-to-digital conversion capabilities of the flight computer system.

Flight Computer

The *NMSUSat* requires on-board computing and software to maintain operations and support the networking experiments. The flight computer system provides

1. interfacing to the communications components;
2. interfacing to the data acquisition system;
3. component monitoring and control;

4. watchdog timer capability to mitigate against lockup.

The baseline design for the flight computer uses a PC/104-based industrial controls computer with an embedded Linux operating system, flash memory, analog-to-digital conversion support, serial ports, and networking support. This computer system is illustrated in Figure 5.



Figure 5 – Baseline flight computer in PC/104 format.

Ground Control Center

The *NMSUSat* is controlled through a ground station on the NMSU campus. The ground software builds upon the control hardware and software currently being used for the *3CS* mission which provides

1. automated tracking and control of the uplink and downlink radio and antenna system;
2. the ability to store and forward command packets for the satellite; and
3. the ability to capture telemetry data.

Additional capabilities that are added to the *3CS* configuration are

1. performing payload management functions;
2. generating command load files; and

- capturing and processing data delivered via the Internet.

The necessary VHF/UHF antenna elements, radios, and low-level control software are presently at the NMSU campus for the 3CS mission. Secure control software using LabVIEW has been developed for 3CS [7] and will form the basis of the ground software here. The block diagram for the ground system is given in Figure 6.

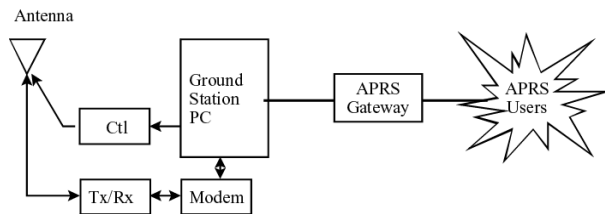

Figure 6 – Block diagram for the ground communications components.

System Functions

To accomplish the mission, system level functions for Configuration Management, Operations, Materials and Safety, and Integration and Test are required. The following paragraphs outline these areas.

Configuration Management. The design of the *NMSUSat* will need to be documented and controlled through a Configuration Management Plan. This plan will be developed under the CMII Model approach proposed by the Institute of Configuration Management. The CMII Model encompasses components of project management, quality assurance, and configuration management. Using the Institute's approach, configuration management will include all of the nanosatellite process management tasks such as: requirements, change, data and release management, and document and records control. The current 3CS mission configuration management plan will be

used as a guide for structuring the actual plan.

Operations. The *NMSUSat* is designed to support experimental operations. For this reason, another early design element is the definition of the operating modes for the satellite. Satellite operations mentors from General Dynamics will work with the students and faculty to define these modes. Additionally, the students having an operational emphasis in their educational program will be made part of the test teams to help train the students and to help structure the tests for operational needs.

Materials and Safety. One of the lessons learned for the 3CS mission was the criticality of the materials and safety process and how it affects the overall design. All materials will be checked for compliance with the NASA materials list. The design will be tempered by the need to pass a flight safety review. This includes structural safety, fracture control, and other potentially hazardous conditions. The documents specified by AFRL on the Nanosat 3 Web page will be used as the guide to the design requirements in this area.

Integration and Test. One area in which students are frequently deficient is formal testing. We will use the 3CS mission as a guide to educate the students in formal testing procedures and how these tests can be structured to be used for manufacturers acceptance testing, unit testing, and integration testing for *NMSUSat*.

Challenges

Naturally, the first time an end-to-end satellite mission is attempted at a university, there are many challenges to be overcome. The main administrative challenge is keeping all of the

faculty and students in the several departments and two colleges working towards the same goal. This type of program has a high “excitement factor” which should keep the parties working towards the shared goal.

The largest technical challenge is the acquisition of the an appropriate attitude control system. This will need to be carefully worked out during the design process. The technical risk assessment for the project components is given in Table 1.

Conclusion

The students, faculty, and staff at NMSU are starting on the process to develop a nanosatellite to measure the earth’s near ultra violet albedo. A successful mission will greatly extend the accumulated knowledge of the radiation in this region. The satellite operations will demonstrate operating the satellite as a node on the Internet to support IP-based satellite communications. The satellite will also validate double capacitor technology for space applications as part of the engineering experiments. Successful completion of the project will greatly enhance the aerospace-related education at NMSU through interdisciplinary design classes.

Acknowledgments

This work is supported by Air Force Office of Sponsored Research Grant F49620-03-1-0168. Additional student support has been provided by the International Foundation for Telemetry.

References

- [1] Horan, S., L. Alvarez, et al., “The Three Corner Satellite Mission,” Proceedings of the International Symposium Formation Flying: Missions & Technologies, Toulouse, FR, October 2002.
- [2] Hennes, J.P., Journal of Geophysical Research, vol. 71 p. 763, 1966.
- [3] Lebedinsky, A.I. et al., Space Research (Russian) Nauka, Moscow, vol. 77, 1965.
- [4] Greer, R.G.H et al. Planet, Space Science, vol. 34, p. 771, 1986
- [5] Pfeffer, A., “AFRL Internal Cargo Unit User’s Guide,” UN-0001, Air Force Research Laboratory Space Vehicles Directorate, Kirtland AFB, NM, March 2003.
- [6] Horan, S. and L. Alvarez, “Preparing a COTS Radio for Flight - Lessons Learned from the 3 Corner Satellite Project,” Proceedings of the 16th Annual AIAA/USU Conference on Small Satellites, SSC02-X-4, Logan, UT, August 2002.
- [7] Mauldin, K., "Networking Satellite Ground Stations Using LabVIEW," Proceedings of the International Telemetry Conference, 02-10-04, San Diego, CA, October 2002.

Table 1 – Risk Assessment of Subsystems for Completing the <i>NMSUSat</i> Project				
#	Area	Assessed Completion Risk	Justification	Risk Mitigation Measures
1	Configuration Management Plan	Low	Use Nanosat 2 CM plan as a guide	
2	Operations Planning	Moderate	Satellite operations is new to faculty and students	Use actual satellite operators as mentors
3	Science Instrument Development	Moderate	Space-rated instrument development is new to faculty and students; components expected to be a major flight safety factor	Base development on balloon-payload expertise
4	Structure	Low	Use 3 Corner Satellite structure as a guide	
5	Power	Moderate	Space-rated solar cell development is new to faculty and students; inhibit methodology is a major flight safety factor	Use 3 Corner Satellite inhibit and solar cell construction as a guide
6	Attitude Control	High	ACS is new to faculty and students	Look to industry mentors and similar programs for guidance
7	Communications	Low	Use 3 Corner Satellite flight radios as a guide	
8	Flight Computer and Data Acquisition	Low		Use ruggedized instrumentation control components
9	Flight Software	Moderate	Space-rated flight software development is new to faculty and students; flight software expected to be a major flight safety factor	Look to industry mentors for guidance
10	Ground Control	Low	Use 3 Corner Satellite ground communications methodology as a guide	