

SSC01-VI-8

Advance Power Technology Experiment for the Starshine 3 Satellite

Phillip Jenkins

OAI, NASA GRC 21,000 Brookpark Rd. MS 302-1 Cleveland OH 44135 PH: 216-433-2233
phil.jenkins@grc.nasa.gov

David Scheiman

OAI, NASA GRC 21,000 Brookpark Rd. MS 302-1 Cleveland OH 44135

David Wilt

NASA Glenn Research Center at Lewis Field, 21,000 Brookpark Rd. MS 302-1 Cleveland OH 44135

Ryne Raffaele

Rochester Institute of Technology, NASA GRC 21,000 Brookpark Rd. MS 302-1 Cleveland OH 44135

Robert Button

NASA Glenn Research Center at Lewis Field, 21,000 Brookpark Rd. MS 333-2 Cleveland OH 44135

Mark Smith,

OAI, NASA GRC 21,000 Brookpark Rd. MS 302-1 Cleveland OH 44135

Thomas Kerslake

NASA Glenn Research Center at Lewis Field, 21,000 Brookpark Rd. MS 500-103 Cleveland OH 44135

Thomas Miller

NASA Glenn Research Center at Lewis Field, 21,000 Brookpark Rd. MS 309-1 Cleveland OH 44135

Abstract. The Starshine 3 satellite will carry several power technology demonstrations. Since Starshine 3 is primarily a passive experiment and does not need electrical power to successfully complete its mission, the requirement for a highly reliable power system is greatly reduced. This creates an excellent opportunity to test new power technologies. Several government and commercial interests have teamed up to provide Starshine 3 with a small power system using state-of-the-art components. Starshine 3 will also fly novel integrated microelectronic power supplies (IMPS) for evaluation.

Introduction

The Kodiak Star mission is scheduled to launch on August 31, 2001. It will carry the Starshine 3 satellite to a circular orbit of 475 km inclined 67°. Starshine 3 is a 36" diameter spherical satellite covered with 1500 1"-diameter mirrors. The primary mission of Starshine 3 is to measure atmospheric density as a function of altitude. This is done by tracking the Starshine 3 orbital decay. Tracking is accomplished using the LIDAR technique and visual sightings against a star field.¹ Starshine 3 is essentially a passive satellite. There is no use of electrical power to assist the orbital

tracking. This makes Starshine 3 an excellent platform to test new power technologies without the burden of mission success depending on the power system. Traditionally, power systems are one of the most conservatively designed systems on a spacecraft. It is therefore especially difficult to introduce new technologies into the power system design due to the customary attitude that new technology must be "flight proven" before it can fly. This "Catch-22" mentality can greatly reduce the pace of innovation.

With the burden of mission success lifted from the power system, we set out to design a small power

system that would use high performance components that are not yet flight proven and will improve future power systems. Three separate power related experiments are included on Starshine 3. They are: high efficiency solar cells and rechargeable lithium-ion batteries, integrated microelectronic power supplies, and an optical transmission test of material used for high efficiency solar concentrator lenses. In the sections below each of these experiments will be described in detail.

Advance Solar Cells and Batteries

The solar cells used on Starshine 3 to power the electronics and transmitter are GaInP/GaAs/Ge triple-junction cells made by Emcore Corporation. Each solar cell is essentially three solar cells monolithically connected in series and stacked vertically on one another. The top cell is a GaInP cell that absorbs only blue light (300 nm to 650 nm in wavelength). The GaAs middle cell collects light from 650 nm to 900 nm, and the Ge bottom cell collects light beyond 900nm. This spectrum splitting technique greatly improves the efficiency over conventional single-junction, silicon or GaAs solar cells. The cells for Starshine 3 are 24% efficient under air mass zero (AM0). This compares to silicon solar cells that are 16% efficient or GaAs cells at 20% efficiency. The Starshine 3 flight will mark the first time Emcore triple-junction cells have flown in space. Emcore is currently producing triple-junction cells that are 26% efficient at AM0.²

The battery used for storage of (excess) power generated by the solar cells is comprised of three

NASA has qualified these cells for one time (primary cells) use aboard the Space Shuttle, making it an excellent candidate for a rechargeable application. The main advantage of lithium-ion technology is higher energy density. Lithium-ion cells weigh approximately one-fourth what Ni-Cad cells weigh for a given Watt-hour rating. The cells of the Starshine 3 battery were stripped out of battery packs made for Canon® video cameras. The battery pack model is BP-930 and can be purchased at most professional camera stores. The Starshine 3 battery consists of three Sony 18650 cells (nominal rating is 4.2V at 1.5 Amp-hours per cell) connected in series. The electrical power required to operate the electronics and transmitter is approximately one Watt averaged over an orbital period.

In order to ease integration of the solar cells onto the spacecraft, it was required that each cell be mounted much like one of the 1500 mirrors on the satellite. Each solar cell is mounted on a modified mirror mount that consists of a machined aluminum coupon about one inch on a side and a hollow stud on the back. The stud passes through the spacecraft shell where it is held in place with a compressive spring and clip. Wires from each solar cell pass through the stud into the spacecraft shell. Once inside the shell, the electrical leads from the solar cells are interconnected into a series string on a small circuit board. The circuit board has bypass diodes for each cell and a blocking diode on the string to prevent battery discharge through the solar cell string. Figure 1 shows a cross section of how the cells are mounted.

Since Starshine 3 is a rotating sphere and its

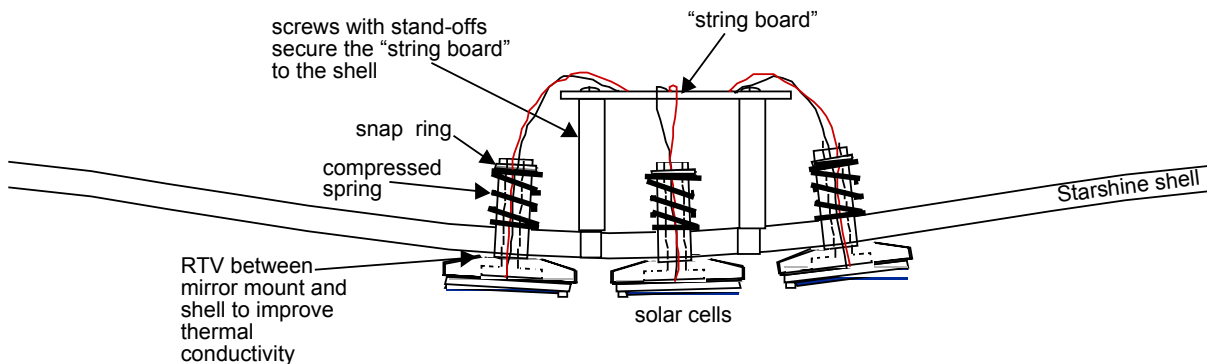

Figure 1) Side View Sketch of a Solar Cell String on the Starshine 3 Shell.

Sony 18650 lithium-ion rechargeable cells. orientation is not controlled, it was necessary to

distribute the solar cells over the spacecraft in order to insure that enough power would be produced regardless of orientation. Eight small strings of solar cells are distributed across the surface of Starshine 3. Each cluster consists of a 6-cell string of 2 cm x 2 cm cells. A picture of the qualification solar cell string (with an IMPS) is shown in Figure 2.

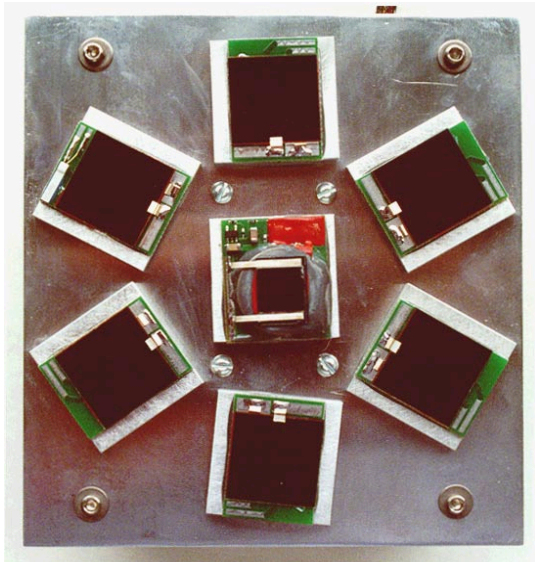

Figure 2) Qualification Hardware of a Starshine 3 Solar Cell String. Pictured in the Center is an IMPS.

Each string can supply 12.4 Volts at 60 mA when fully illuminated. On average, three clusters will be partially illuminated at any one time providing approximately 140 mA at 12.4 Volts to the power bus. The battery controls the operating point of the solar cell strings. Once the battery is charged to 12.4 Volts, the charge control circuitry shunts excess power into a dummy load.

The charge control circuitry is shown schematically in Figure 3. There is no under voltage protection of the battery. The only way to recover from a low battery voltage would be to temporarily shut down the transmitter via a ground command, allowing the battery to recharge. The voltage limits of operation are between 11 Volts and 12.4 Volts for the Starshine 3 electronics. The battery capacity is nominally 0.9 Amp-hours in this range. The anticipated discharge should not exceed 0.08 Amp-hours during an orbit. Thus the total depth of discharge compared to the nominal rating of the battery (1.5 Amp-hour) is 5.3%. The power system will be characterized by measuring

the current produced by each string, the battery voltage, and the battery charge/discharge current.

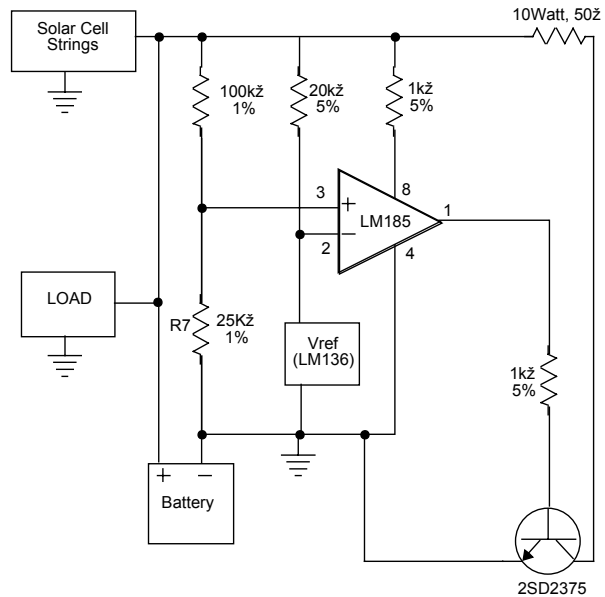

Figure 3) Schematic Diagram of the Electrical Circuit used to Control Battery Charging.

Micro Integrated Power Supply

The development of small micro- and nano-satellites has generated a need for smaller lightweight power systems. Thin film batteries and solar cells are ideally suited to such applications. The necessity for both generation and storage of power for microelectronic applications can be achieved by combining a thin film photovoltaic array with a thin film lithium-ion battery into what is called an integrated microelectronic power supply (IMPS). These supplies can be combined with individual satellite components and are capable of providing continuous power in a variety of illumination schemes. It is a technological goal of IMPS development to have all components seamlessly integrated on a common substrate using thin film batteries and thin film solar cells. The Starshine 3 IMPS are just the first step toward this goal and will provide valuable experience in design and operation of IMPS in a space environment.

Starshine 3 will fly five experimental integrated microelectronic power supplies pictured in Figure 4.³ The experimental integrated microelectronic power supply is a stand-alone device that provides power generation, storage, and management in one

compact package. The Starshine 3 IMPS consists of a solar array, a rechargeable battery, and power management electronics all fitting on one square-inch of circuit board. The IMPS are designed to deliver a constant 20 μA through a 1000 Ω platinum temperature sensor. The solar array is a one square centimeter, monolithically interconnected module (MIM)⁴ of seven GaAs solar cells connected in series. The array output is nearly 7 Volts and can deliver up to 3 mA of current to the load and/or charging of the battery.

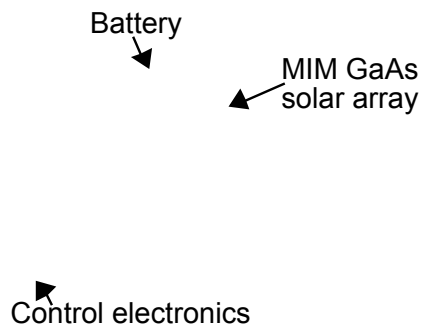

Figure 4) Photograph of a Starshine 3 Integrated Microelectronic Power Supply (Approximately Life Size).

The IMPS energy storage is a high capacity 3-Volt manganese/lithium-ion rechargeable battery. The battery is a Panasonic ML2020 with a capacity of 45 mA-hr rated for a continuous 100 μA load. The power management electronics consists of a micro-power voltage regulator and a blocking diode. The voltage regulator (MAXIM 1726EUK)

keeps the battery from charging above 3 Volts. The blocking diode prevents current from flowing back through the array when it is in the dark. The load side includes two, P-type MOSFETS that shut off the load from the IMPS below 2.3 Volts. Figure 5 shows the complete IMPS and load circuitry. All of the electronic components were selected to minimize parasitic losses in the circuit and avoid draining the battery. Most of these electronics were necessary to avoid damage to the battery that would reduce its cycle life. Ideally, the solar array voltage and size could be matched to the battery voltage and charge current. A blocking diode could also be integrated onto the array eliminating the need for electronics.

Testing Concentrator Lens Materials

Concentrator solar arrays add efficiency and high radiation hardness to a power system. One such system in use is the SCARLET 2 Array⁵ on the Deep Space 1 spacecraft. However, the structure needed to support concentrator lenses (or reflectors) can offset some of the benefit of a concentrator system. One concept to reduce the mass of the concentrator assembly is to use an inflatable Fresnel lens array for solar concentration.⁶ One of the technological challenges for the inflatable array is to develop a flexible lens material that will not degrade in the harsh environment of space. The lens material of choice is a specially processed, transparent silicone rubber used for bonding cover glass to solar cells. Starshine 3 will monitor the transparency of two silicone samples as they are

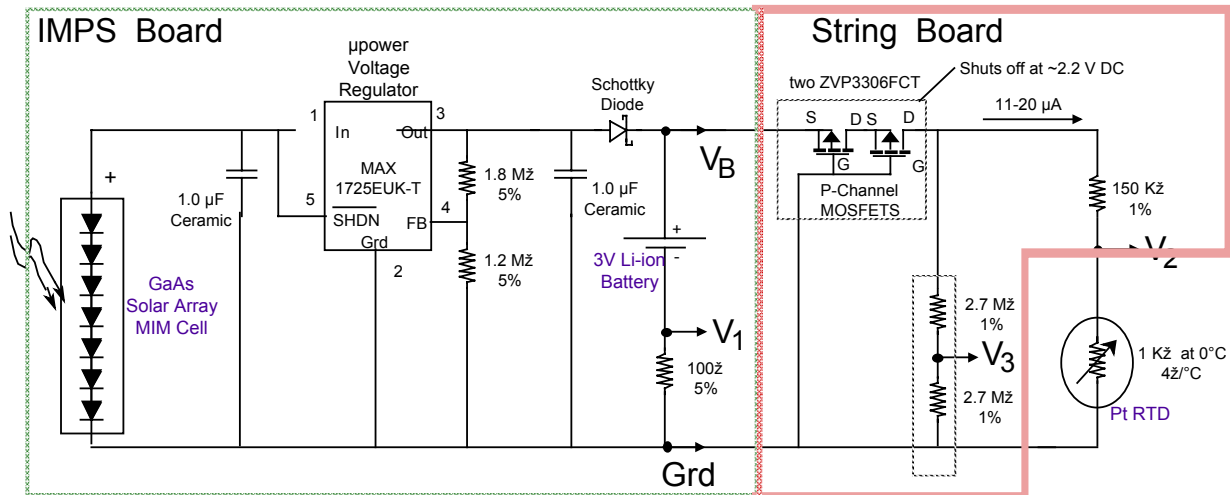

Figure 5) Electrical Schematic of the Starshine 3 IMPS Evaluation Circuit.

exposed to the space environment.

Summary

Starshine 3 has the unique opportunity to test new power technologies with little or no risk to the Starshine primary mission. Advance solar cells, batteries, silicone lens material and novel integrated micro power supplies will be demonstrated on Starshine 3.

Acknowledgements

The authors wish to thank the numerous government and commercial sponsors of this project, including the Photovoltaics Branch of the NASA Glenn Research Center at Lewis Field, the Naval Research Laboratory, the Ohio Aerospace Institute, Emcore Corporation, TRW and ITN Energy Systems. The authors also wish to thank Prof. Gilbert Moore, of Project Starshine, Dr. Aloysius F. Hepp, at NASA GRC, Dr. Michael Batchelder of the South Dakota School of Mines and Dr. Don Lafevre, of Cynetics Corporation.

References

¹ Gil Moore, Bill Braun, Phillip Jenkins, Walter Holemans, and Don Lefevre, "Starshine Missions in 2001," Proceedings of the 15th Annual/USU Conference on Small Satellites, Logan UT, August 2001.

² Details of the Emcore GaInP/GaAs/Ge solar cell can be found at the web address:
http://www.emcore.com/html_documents/Photovoltaics.htm

³ R.P. Raffaele, J. Underwood, D. Scheiman, P. Jenkins, M.A. Smith, J. Maranchi and P. Kumta, D.M. Wilt, R.M. Button, A.F. Hepp, O.P. Khan, J. Harris, W.F. Maurer and C. R. Clark, "Integrated Microelectronic Power Supply," Proceedings of IECEC'01 36th Intersociety Energy Conversion Engineering Conference Savannah, Georgia, July 2001.

⁴ David M. Wilt, Naivid S. Fatemi, Phillip P. Jenkins, Richard W. Hoffman, Geoffrey A. Landis, and Raj K. Jain, "Monolithically Interconnected InGaAs TPV Module Development," Proceedings of the 25th

Photovoltaics Specialists Conference, Washington D.C., May 1996.

⁵ Murphy, D.M., Allen, D.M., "SCARLET Development, Fabrication and Testing for the Deep Space 1 Spacecraft," Proceedings of the IECEC, Honolulu, HI, August 1997.

⁶ Mark J. O'Neill, Michael F. Piszczor, "Inflatable Lenses for Space Photovoltaic Concentrator Arrays," Proceedings of the 26th Photovoltaics Specialists Conference, Anaheim, CA, September 1997.