

SSC99-XI-7

Development of Shape Memory Alloy (SMA) Actuated Mechanisms for Spacecraft Release Applications

Shawn H. Smith

Starsys Research Corporation, 4909 Nautilus Ct. N., Boulder, CO 80301, 303-530-1925
smith@starsys.com

David Downen

Starsys Research Corporation, 4909 Nautilus Ct. N., Boulder, CO 80301, 303-530-1925
dowend@starsys.com

Eugene Fossness

Air Force Research Laboratory, Albuquerque, NM, 505-846-7883

Andrew Peffer

Air Force Research Laboratory, Albuquerque, NM, 505-853-6322
peffera@plk.af.mil

Abstract. Current methods of deploying spacecraft payloads typically employ explosive-type separation devices which do not address shock concerns and are not resettable without disassembly from the spacecraft or significant refurbishment of parts. Other separation mechanisms exist which eliminate explosives, but also do not offer reduced shock or the advantages of in-situ resettable.

Several new, shape-memory alloy (SMA) actuated release mechanisms have been developed for satellite release applications for loads of 500 lbf and greater. These mechanisms all offer fast, non-pyro releases and are completely testable and reusable while mounted on the spacecraft.

The Qwknut and the Low-Force Nut (LFN) are suitable for release applications up to 3000 lbf, while the Fast-Acting, Shockless Separation Nut (FASSN) is suitable for higher load releases above 5000 lbf. FASSNs have been successfully prototyped for release applications of 80,000 lbf.

Applications for SMA mechanisms include satellite hold-down and release from the launch vehicle, hold-down and release of solar panels, and hold-down and release of cover panels and satellite appendages.

Introduction

Current methods of releasing payloads from spacecraft boosters typically employ pyrotechnic separation devices which have the advantage of fast, simultaneous release times, but deliver high shock loads to surrounding structure and create a stressing environment for spacecraft components. The shock generated from these devices comes mainly from the instantaneous release of strain-energy stored in the release bolt and the mounting structure. At higher loads, this release of built up strain energy can be damaging to sensitive electronics. As important are the safety and handling concerns associated with the use of pyrotechnics. All of these factors combined have led to efforts to find non-pyro alternatives for space craft hold-down and release applications.

Traditional non-pyrotechnic release devices which maintain the fast-release time do not offer the advantage of in-situ reusability. These mechanisms do not provide the added reliability of testing the device as it is flown. Slower-acting, non-pyrotechnic release alternatives which may be motor or thermally driven, generally offer reusability and solve the strain-release shock problem, but at the cost of substantially slower release times and decreased simultaneity between units.

Several innovative new mechanisms have been developed which offer fast-acting, non-pyrotechnic releases. The Low-Force Nut (LFN), Qwk-nut (QN), and Fast-Acting, Shockless Separation Nut (FASSN) each rely on shape-memory alloy (sma) materials to achieve fast, simultaneous release. Each of these mechanisms is fully resettable and reusable while on the space craft and therefore offer the advantage of being able to test the mechanism exactly as it is flown. The FASSN offers the additional advantage of being a shockless release device. The LFN also offers substantially reduced source shock as well.

The QN and the LFN are suitable for release applications up to 3000 lbf, while the Fast-Acting, Shockless Separation Nut (FASSN) is suitable for higher load releases above 5000 lbf. FASSNs have been successfully prototyped for release applications of 80,000 lbf.

This paper will discuss the following topics:

1. The general design of each mechanism.
2. Performance specifications of each mechanism.
3. Background development and flight history.

Low-Force Nut (LFN) Design

Shown in Figure 1, the LFN is a small, resettable, reusable mechanism appropriate for hold-down and release applications less than 3000 lbf. While many SMA mechanisms use SMA wire as a low-force, small-stroke “trigger” for mechanism operation, the LFN uses redundant SMA springs as high-force, long-stroke prime mover to release the device. When a current is applied to the SMA actuation spring, the spring expands and generates approximately 20 lbf over .25 inches of stroke. This movement releases a spring-loaded ball lock latch mechanism which retains a set of 3 thread segments. When the ball lock is released, the thread segments separate radially from the thread of the attaching bolt, allowing the bolt to release. Internal parts are allowed to stroke into the SMA reset spring which serves to mitigate some of the shock generated by the release. Figure 2 illustrates a comparative shock response spectrum for a 3000 lbf release of the LFN, G&H Separation Nut, and a pyrotechnic separation nut. The data shows that the LFN does offer some shock mitigation. The LFN can be reset remotely by applying current through the SMA reset spring

LFN Performance

Function times for the LFN are highly variable and depend on the current available to power the device. Release times on the order of .050 seconds can be achieved with sufficient current. Also, simultaneity within 2 milliseconds has been achieved. With suitable accompanying circuitry, the device can be triggered from existing pyro-driver units. Table I illustrates the qualification specifications for the LFN.

LFN Development and Flight History

The LFN was developed and qualified by Lockheed Martin, Astronautics Division for a flight experiment on the Air Force Research Laboratory's Mightysat 1 spacecraft. The experiment consists of four release devices and support electronics suitable for obtaining acceleration and separation times for the LFN, a Two Stage Nut (another new SMA based separation mechanism), a G&H burn-wire device, and a Hi-Shear pyrotechnic separation

nut. The LFN technology has been licensed to Starsys Research Corporation (SRC) by Lockheed Martin. Funding for the development of the LFN was provided for by the Air Force Research Laboratory, Albuquerque, New Mexico. Further research is continuing on the LFN to make the unit truly compatible with existing pyrotechnic firing electronics without the need for support electronics.

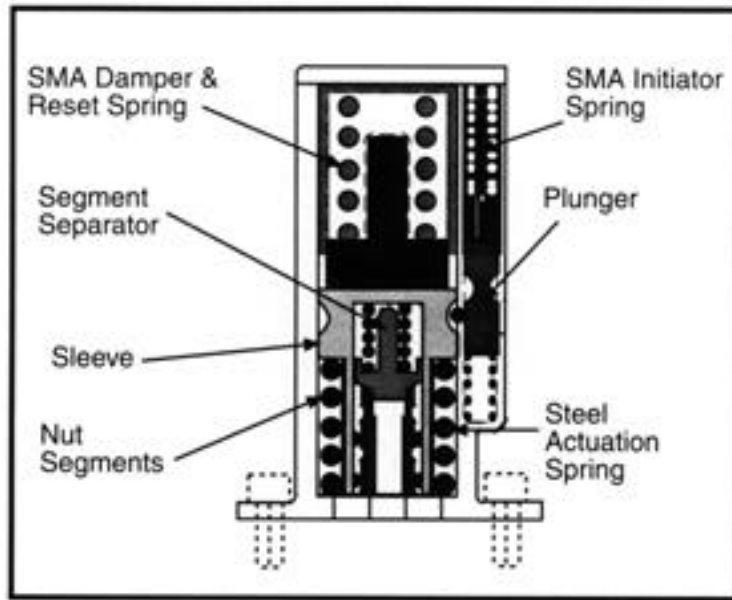

Figure 1: Low Force Nut

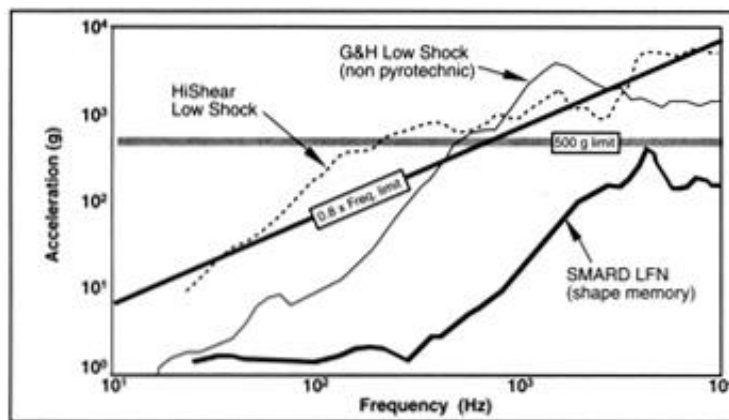

Figure 2: LFN Shock Response, 3000 lbf Release

Table I: LFN Performance Specifications

Description	Specification	Comments
Thread Size	¼" –28 bolt	
Nominal Load Range	500 lbf to 3000 lbf	
Ultimate Load Capacity	3500 lbf	
Function Time	< 1.5 seconds	30 amps, 1 circuit, ambient temperature
Temperature Range	-40°C to +60°C	
Random Vibration	10 Grms, 3 min/axis	
Shock	8000 G's	
Vacuum	1 x 10 ⁻⁴ torr	Higher vacuum acceptable
Firing Current	30 amps/1.5 seconds	Higher currents result in faster actuation times.
Circuit Resistance	.25 Ω ± .05 Ω	

Qwknut

The Qwknut is a shape-memory actuated release device suitable for release applications of approximately 3000 lbs or less. What separates the Qwknut from the LFN is that the Qwknut responds to existing pyrotechnic firing pulse requirements without additional support electronics. Shown in Figures 3 and 4, the Qwknut consists of 4 thread segments which grasp the threads of an attaching bolt, similar to the method used by a standard pyrotechnic separation nut. When a standard pyrotechnic firing pulse is applied to a shape-memory trigger wire, a spring-loaded retaining mechanism is released which allows the thread segments to stroke radially and release the bolt. In typical pyrotechnic separation nuts, gas pressure is used to drive a retainer past the thread segments to allow them to stroke radially. Significant sliding

friction is generated at the interface of the retainer and the thread segments. Sliding friction is often difficult to predict and can affect functional margins. The Qwknut avoids sliding friction by retaining the thread segments with a series of caged rollers. The cage rollers rotate until the rollers line up with a series of grooves which allow the rollers and the thread segments to stroke radially. The concept thus relies on rolling friction and allows greater functional margins and more predictable functional behavior. Redundant shape memory wires are used. Either or both shape memory wires are capable of releasing the device. Since shape memory is heat sensitive, cut off switches are used to turn off the current to the shape memory wire after its work has been done. This allows repeated use for ground test purposes. The cut-off switches can be bypassed for flight, since reusability is no longer an issue.

Qwknut Performance

Figure 5 illustrates typical load release times for various applied currents. Higher currents result in decreased function times for the mechanism at all temperatures. Figure 6 illustrates typical current and load vs. time test data at 5.6 amps applied current and ambient temperature. Nominal function times at ambient temperature using approximately 3.5 amperes current are on the order of 30 msec from first application of current to no load left on the bolt. Table II depicts the qualification specifications for the Qwknut.

Qwknut Development and Flight History

The Qwknut was invented and developed at Starsys Research Corporation. Development of the mechanism was completed approximately at the end of 1998. Qualification of 2 units was begun in the spring of 1999 and is scheduled to be completed during the summer of 1999. The Qwknut has been selected to release the United States Air Force Academy Falconsat, which is scheduled to launch in the fall of 1999. Four Qwknuts will be used to hold down the satellite. All four will be fired in parallel simultaneously.

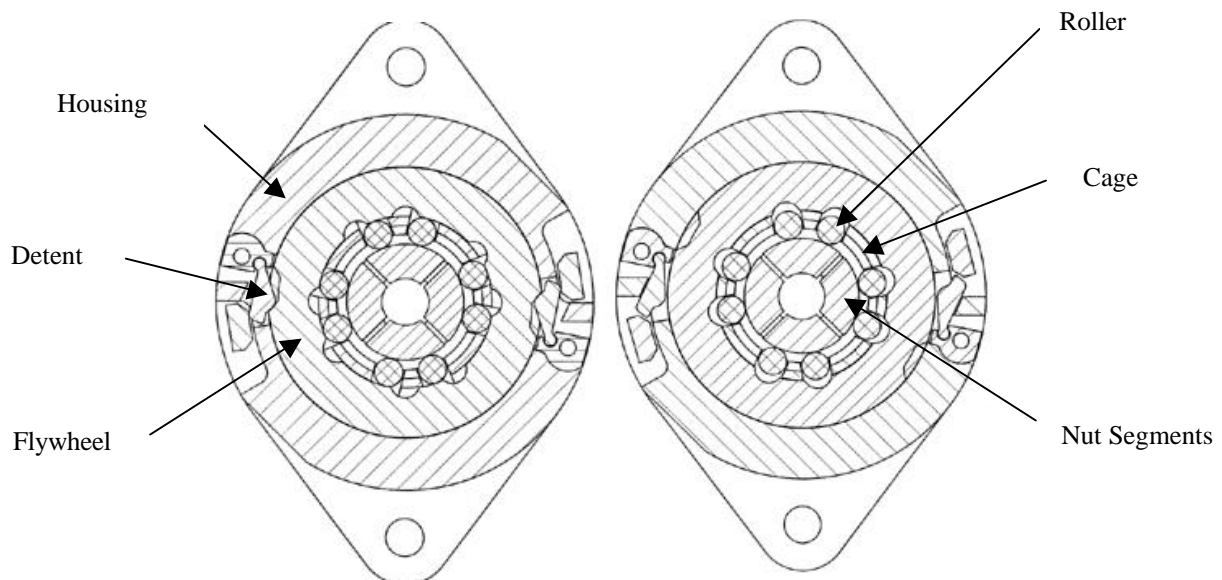

Figure 3: Qwknut in latched and released conditions respectively



Figure 4: Qwknut

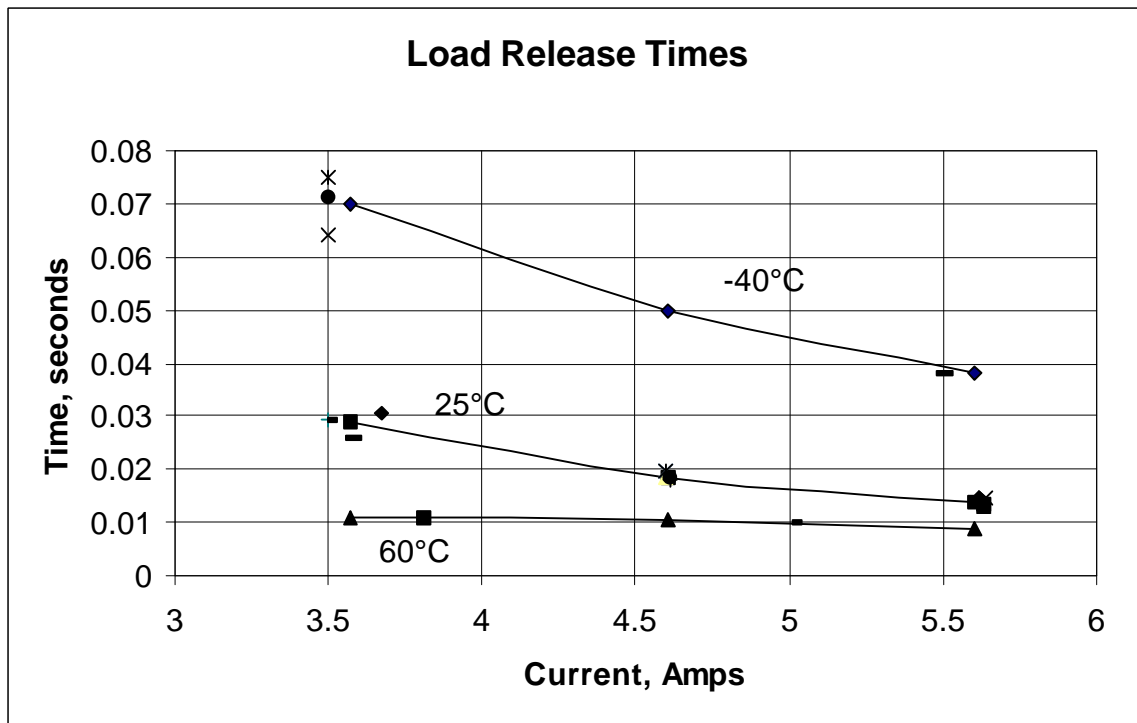

Figure 5: Release time vs. current

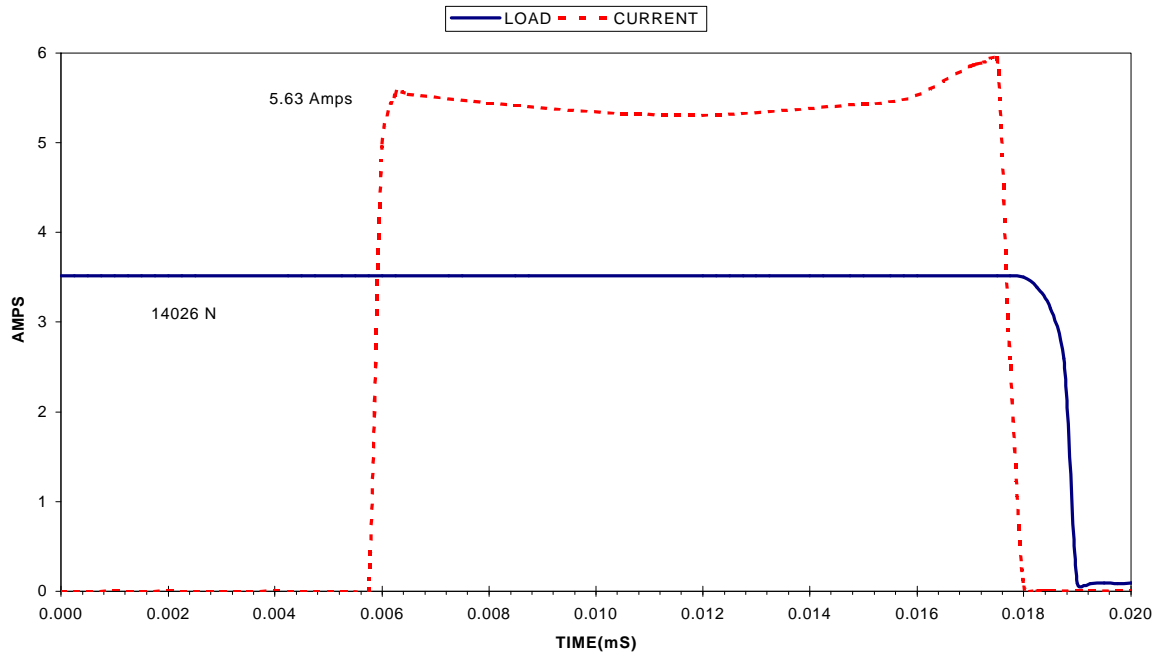

Figure 6: Typical response curve under ambient conditions

Table II: Qwknut Performance Specifications

Description	Specification	Comments
Thread Size	1/4" -28 bolt	
Nominal Load Range	500 lbf to 3000 lbf	
Ultimate Load Capacity	3750 lbf	
Function Time	< 30 milliseconds	3.5 amps, 1 circuit, ambient temperature See Figure 6 for temperature curves
Temperature Range	-50°C to +60°C	
Random Vibration	35 Grms, 3 min/axis	
Vacuum	1 x 10 ⁻⁴ torr	Higher vacuum acceptable
Firing Current	3.5 to 5.0 amps for 100 milliseconds	Higher currents result in faster actuation times.
Circuit Resistance	4.0 Ω ± .2 Ω	

FASSN

Illustrated in Figures 7 and 8, the FASSN consists of 5 main components: a Housing, a long-lead threaded Bolt/Flywheel Nut assembly, an internal Latching Mechanism, an SMA Actuator, and a Bolt Catcher. Under tension, the long-lead thread of the Bolt/Flywheel Nut assembly generates a backdrive torque which is reacted internally



Figure 7: FASSN Release Mechanism

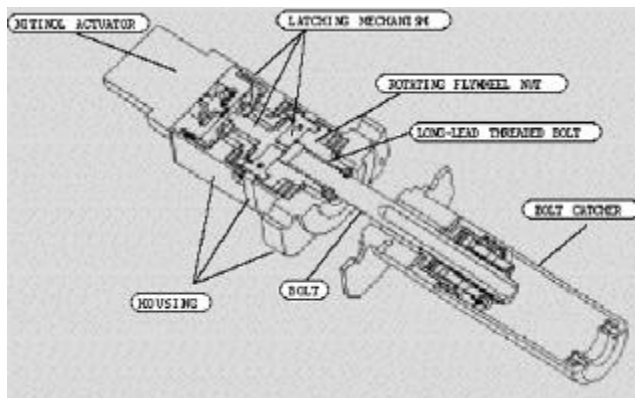

Figure 8: FASSN Cross-Section

on the FASSN Housing by the Latching Mechanism. When an electrical firing pulse of 3.4 amperes/30 msec, minimum is applied, the SMA Actuator rotates and releases the internal Latching Mechanism. This allows the Flywheel Nut to rotate under the backdrive torque which releases the load and

ejects the bolt into the Bolt Catcher. The Flywheel Nut is mounted on a stack of needle roller bearings and thrust washers. During release, strain-energy in the Bolt is converted to rotational energy in the spinning Flywheel Nut which dissipates harmlessly within the mechanism.

The internal Latching Mechanism has several key features, critical to the design:

1. It is self-locking, so that during release the components of the Latching mechanism retract away from all latching points and the Flywheel Nut spins freely. This minimizes rattle within the mechanism and reduces source shock levels.
2. It is resetable by activating spring loaded plungers which drive the latching mechanism back to its original latching position. The plungers are activated when the Bolt is fully re-inserted into the Flywheel Nut.
3. Friction vectors at points of sliding contact pass through rotational pivot points. This minimizes the effects of sliding friction in the design and makes the mechanism more predictable and repeatable.
4. It provides a large gear reduction, so that minimal torque is required from the shape-memory actuator to release the device. Although backdrive torques exceeding $79.1 \text{ N}\cdot\text{m}$ ($700 \text{ in}\cdot\text{lbf}$) have been measured at approximately 62.27 kN ($14,000 \text{ lbf}$ preload, less than $.0848 \text{ N}\cdot\text{m}$ ($.75 \text{ in}\cdot\text{lbf}$) of torque is required from the shape memory actuator to release the bolt. The shape memory actuator has a minimum torque output of $.452 \text{ N}\cdot\text{m}$ ($4 \text{ in}\cdot\text{lbf}$), so there is over a 4:1 torque margin on release.

The SMA Actuator allows the FASSN to be fired using a firing pulse identical to that

used in pyrotechnic separation nuts. It has completely redundant firing circuits and contains a cut-off switch on each firing circuit which shuts off the current to the Actuator after functioning. These cut-off switches are necessary for ground testing only and are bypassed during flight.

FASSN Performance Specifications

Testing was conducted to qualify the ½” FASSN specifically for the Lockheed-Martin P-59 program and for general space flight purposes. Table III illustrates the general performance specifications. The test program involved eight FASSN assemblies. All FASSNs used in the test program had successfully passed an acceptance test program prior to qualification. Of the eight FASSNs used in the test program, four were tested at a nominal preload of 9750 lbs and the other four were tested at a nominal load of 5000 lbs. Additional testing was done at 3500 lbs and at 14,000 lbs to establish overall limits of capability. All eight FASSNs were subjected to tests of random vibration, pyrotechnic shock, thermal vacuum at hot, cold, and ambient temperatures, rapid transition from atmospheric pressure to vacuum (rapid pumpdown), and a basic life of 25 releases. These tests were conducted over a range of applied currents from 3.4 amperes to 5.6 amperes. Additionally, thermal characterization, misalignment, corrosion, fatigue, extended life, creep (extended storage at preload), and pull to failure tests were performed on selected FASSNs throughout the test program. All together, more than 400 test firings were performed as part of acceptance and qualification. Figure 9 illustrates typical function test data results for the ½” FASSN. Source shock testing was not performed as part of the acceptance or qualification test program, but was instead

performed as part of development for information purposes only. The FASSNs used for shock testing were assembled as part of the flight manufacturing lot, however.

The FASSN technology is scalable to higher or lower loads depending on the application. Development FASSNs designed to carry loads as high as 75,000 lbs tension have been built and tested. There appears to be very little increase in SRS values for significantly higher loads. This is evident in Figure 10 which illustrates results of source shock testing at 37,000 lbs preload for the FASSN compared to equivalent pyrotechnic separation nuts. At 10,000 Hz, the worst case SRS for the FASSN was approximately 200 G's compared to approximately 20,000 G's for the pyrotechnic separation nut. This represents a 2 orders of magnitude decrease in worst case SRS at high frequency.

FASSN Development and Flight History

The FASSN was developed jointly by Starsys Research Corporation, Lockheed Martin, and the Naval Research Laboratory. The technology is licensed exclusively to Starsys Research Corporation. A total of 4 prototypes were built and tested over a period of a year and a half. The last two prototypes were essentially the qualification configuration and were tested extensively. Over 300 development tests were performed. As a result of successful development, the FASSN was chosen as the release device for the STEX satellite in June of 1996. A lot of 16 flight FASSNs were fabricated by February of 1997. All 16 units were acceptance tested and 8 were randomly selected for qualification. Over 400 qualification tests were done on the 8 units. Qualification testing was completed in September of 1997. The first flight use of the FASSN occurred in October of 1998,

when 4 FASSNs successfully released the STEX satellite from a Taurus launch vehicle.

Table III: FASSN Specifications

Description	Specification	Comments
Thread Size	12 mm(½ in)	
Nominal Load Range	22.24 kN to 44.48 kN (5000 lbf to 10000 lbf)	
Ultimate Load Capacity	62.27 kN (14000 lbf)	
Function Time	< 28 msec	First application of current to 20% load on bolt
Temperature Range	-15°C to +60°C	
Misalignment/offset	.3° max angular/ .030" offset	
Simultaneity	± 2 msec	Units at same temperature. Between 3.5 amps and 5.6 amps, -15C to +50C, 1 circuit vs. 2 circuits, the delta is 18 msec.
Random Vibration	24 Grms, 3 min/axis	
Shock	8000 G's	
Vacuum	1 x 10 ⁻⁴ torr	Higher vacuum acceptable
Firing Current	3.5 A , min 30 msec min pulse	Higher currents result in faster actuation times. Cut off switches in Actuator allow for ground testing at higher currents.
All-Fire	1.8 amps, 70 msec	
No-Fire	.75 W	.43 amps for 5 minutes
Circuit Resistance	3.8 Ω ± .20 Ω	
EMI/RFI	20 dB	

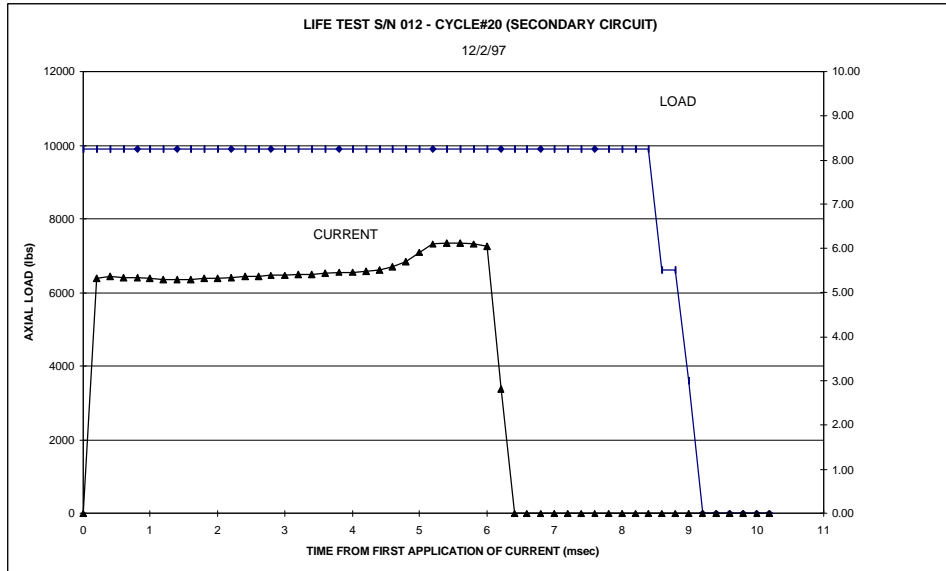

Figure 9: Typical 1/2" FASSN Performance Data

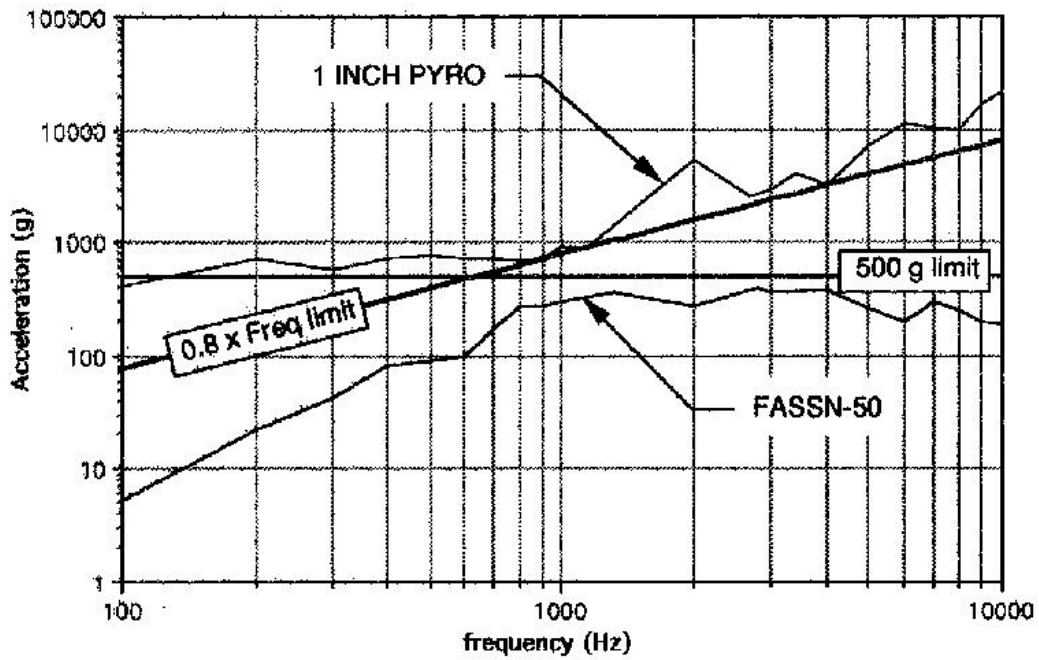

Figure 10: Comparative Source Shock Test Results