

University of Tokyo's CubeSat Project

— Its Educational and Technological Significance —

Yuichi Tsuda, Nobutada Sako, Takashi Eishima, Takahiro Ito,
Yoshihisa Arikawa, Norihide Miyamura, Akira Tanaka and Shinichi Nakasuka

Department of Aeronautics and Astronautics, University of Tokyo
7-3-1, Hongo, Bunkyo-ku, Tokyo 113-8656, JAPAN
TEL: +81-3-5841-6609
E-mail:yuichi@space.t.u-tokyo.ac.jp

Abstract

This paper describes outline of the University of Tokyo Intelligent Space Systems Laboratory (ISSL)'s CubeSat "XI" for the demonstration of the pico-satellite bus technology and validation of the commercial-off-the-shelf parts in space as well as the earth imaging mission. CubeSat project is the international joint program, which aims for developing and actually launching 10cm cubic satellites weighing less than 1kg to the earth's orbit. 18 CubeSats developed by Japanese and U.S. institutes are to be launched by the Russian launch vehicle "Dnepr" in May, 2002 to the Sun-synchronized orbit. The project in ISSL is conducted by 20 space engineering students as a material of education.

1 Introduction

Intelligent Space Systems Laboratory (ISSL), University of Tokyo is now developing a pico-satellite "XI" [sai] in the CubeSat program. XI is the technology demonstration satellite to validate the pico-satellite bus system and the space use of commercial-off-the-shelf (COTS) parts. XI is also equipped with a CMOS camera for experimenting an imaging technology.

CubeSat, as imagined from its name, is a cubic shaped satellite, whose size is $10 \times 10 \times 10 \text{ cm}^3$ and its weight is restricted within 1kg. 18 CubeSats from 12 Japanese and U.S. institutes are to be launched together by the Russian launch vehicle "Dnepr" in May, 2002.

Because the objective of CubeSat program is focused on education, ISSL has participated in the project so that students can experience the whole cycle of satellite development, from conceptual design until fabrication, integration, launch and operation. Also the students have learned how the project can be managed effectively. For this objective, ISSL has performed two years of CanSat projects¹, whose result is heavily applied to the CubeSat project.

This paper describes outline and the development status of ISSL's CubeSat "XI", and discusses the educational and technological significance of this project.



Figure 1: Image of XI satellite on Orbit

2 CubeSat Program

CubeSat program was originally adopted in the University Space Systems Symposium (USSS) in Hawaii in November, 1999, and has been promoted mainly by Japanese and U.S. universities community. The important consensus was that in this program, a launch opportunity is to be prepared every one or two year(s) to CubeSat developers.

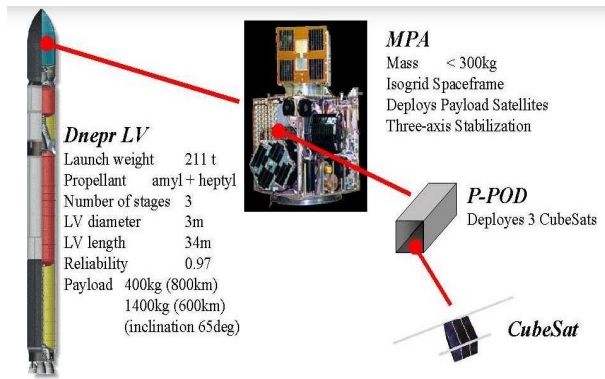

Figure 2: Launch Configuration

This program has started primarily for an educational purpose to improve students' skill of space engineering and project management, and is promoted in an international cooperative manner. Developers have exchanged technical and interface information mainly via e-mail and web pages. In addition, the participants in Japan constantly hold joint meetings every one or two months to share and improve their knowledge and information on satellite development.

Figure 2 shows the configuration of the coming launch. CubeSat is put in the carrier called P-POD developed by California Polytechnic State University. A P-POD carries 3 CubeSats in its square tube-structure. 6 P-PODs are attached to Multiple Payload Adaptor (MPA) developed by One Stop Satellite Solutions Inc.(OSSS), which means 18 CubeSats will be brought to space together in this launch. MPA is one of the payloads of Dnepr launch vehicle of ISC Kosmotras, Russia. The launch is scheduled in May, 2002 from Baikonur Space Center in Kazakhstan, Russia. The orbit is sun-synchronous at 650km, and the local time of the orbit is not fixed yet.

All CubeSats are to be delivered to OSSS in November, 2001, where the integration and the synthetic testing such as thermal vacuum testing and vibration testing are to be conducted combined with P-PODs and MPA. MPA with P-PODs and CubeSats aboard will be shipped to Russia at least one month prior to launch.

3 Outline of XI

XI is a 10cm cubic satellite with solar cells on its 6 surfaces, one 56cm monopole antenna and one 35cm (tip to tip) dipole antenna attached perpendicular to each other. XI has a camera, whose lens is exposed from the same surface as where antennae

Table 1: Outline of XI satellite

Size	$10 \times 10 \times 10 \text{ cm}^3$
Mass	1 kg
Electronics	
OBC	PIC16LF877, 8bit, 1MIPS
Data Recorder	EEPROM 256kbyte
Communication	
Uplink	144MHz Band, FM, 1200bps
Telemetry	430MHz Band, FM, 1200bps, 0.8W
Beacon	430MHz Band, CW Morse, 80mW
Antenna	Monopole (Uplink), Dipole (Telemetry/Beacon)
Power	
Solar Cells	1.2W (Average), Si Cells
Battery	6.4AH Lithium-Ion Battery
Attitude	Passive, Along-Magnetic Field
Sensors	Temperature Sensors, CMOS Camera

are attached. Maximum generated power is 1.2W, which is charged to the 8-paralle lithium-ion batteries. Figure 1 shows the image of XI satellite on orbit. Table 1 summarizes the outline of XI.

The planned orbit for CubeSats, including XI, is sun-synchronized orbit with altitude of 650km. Because the local time of the orbit is not fixed yet, XI may experience the sunshine duration of 60% to 100% per orbital period. XI is passive-controlled using permanent magnet and libration damper. This helps to make the satellite thermally uniform (i.e. barbecue roll.)

The mission of XI is an engineering demonstration of the super-small satellite development technology. The technology to be tested in XI are;

- Integrated spacecraft controller using low-cost, low-power consumption COTS processor PIC16LF877 (8bit, 1MIPS, 20mW).
- SEL/SEU protection system.
- Redundant system using two independently powered processors.
- Super-small amateur band transmitter/receiver and beacon system.
- Self-made lithium-ion battery charger.
- 15,000 pixels 16bits color CMOS camera with on-board image evaluation.
- Compact ground station based on COTS equipment.

4 Missions of XI

4.1 Mission Description

As CubeSat program is the first attempt for ISSL to develop and actually launch a satellite to orbit

individually, the design of XI is aimed for verifying the basic functions necessary for any spacecraft systems, such as on-board software, communication, power management and environmental tolerance. Mission definition we set is as follow;

Mission Statement

“To establish the indispensable technologies in developing super-small satellite system.”

Missions

- Gathering the satellite health information via beacon signal
- Command uplink & data downlink
- Telemetry data broadcasting service
- On-orbit verification of the COTS components
- Validation of imaging technology using CMOS camera

XI broadcasts Morse coded CW beacon signal on 430MHz band. Important health data is to be broadcasted via this beacon constantly. As a telemetry and command system, XI uses 430MHz band for downlink and 144MHz band for uplink (J-mode). Both up/down are in FM AFSK packet communication at 1200bps.

The format of downlink and beacon will be open to public. We are going to appeal to hams all over the world for cooperation to search for and monitor our satellite.

The components and materials used in the satellite are mostly COTS parts. Evaluating the availability of these parts in space is of one of our interests in this mission.

XI is equipped with CMOS camera, which is also a COTS part. We plan to conduct the experiment of taking pictures of the earth and the mother ship MPA, as an extended mission.

4.2 Success Levels

To clarify the objective of our project and mission goal, we set the success levels of the project. Because the CubeSat program focuses primarily on education, we consider that the process of the development and management are the most important outcomes.

Minimum Success

- Acquiring the important technology and knowledge on space engineering through designing and fabricating a spacecraft.
 - Establishing overall work flow of the satellite developing project

- Establishing a methodology of spacecraft design
- Cultivating the fabrication technique
- Establishing sequence and method of several environmental and integration testing
- Proceeding with the project smoothly so as to bring the spacecraft to the launchable condition by the deadline

Medium Success

- Receiving signals from the spacecraft.
 - Surviving in the actual launch environment
 - Successfully verifying the function of the communication system
 - Gathering house keeping data

Full Success

- Success in uplink and downlink.
 - Successfully commanding the spacecraft by uplink
 - Getting downlink data as a reaction to the command uplink

Advanced Success

- Success in CMOS camera imaging operation.

5 System Design

5.1 Functions Distribution and Design Strategy

Our project is performed by 6 subsystem groups; (1) OBC & Electronics subsystem, (2) Communication subsystem, (3) Power subsystem, (4) Structure subsystem, (5) Environment subsystem, (6) Ground Segment subsystem. Former 4 groups develop the onboard components and structures, while environment group analyzes the environmental effect on XI on orbit such as thermal environment, radiation, outgas, etc. Ground segment group prepares all what is needed for commanding and receiving the signals from XI at ISSL’s ground facility.

XI applies slot-in tray system for printed circuit boards layout (Figure 3,4). A mother board,

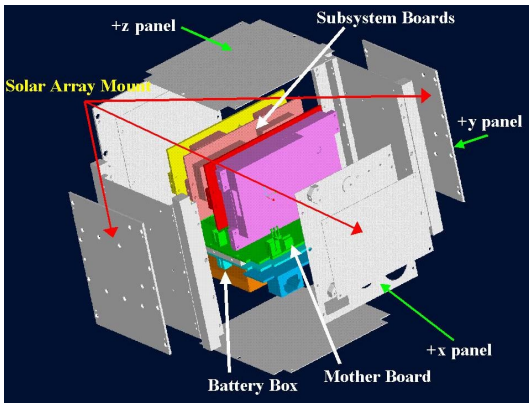

Figure 3: Internal Structure of XI Satellite

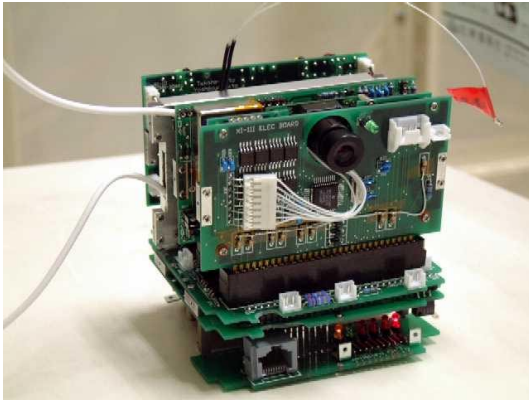

Figure 4: EM Model in Development

on which three 60 pin sockets are attached is distributed together with batteries at the bottom of the satellite. 3 subsystem boards developed by OBC & electronics group, communication group and power group are slotted vertically in the sockets. This system is especially effective, for once socket interface is fixed, each subsystem group can develop its components individually. This system also reduces the amount (weight and space) of harnesses, which is critical for this small satellite.

OBC board is for command & data handling. This subsystem has a main on-board processor and EEPROMs for data storage. The CMOS camera and its controller unit are also mounted on this board. This subsystem keeps the spacecraft time, manages sequential tasks, receives command and transmits data from/to communication subsystem, conducts A/D conversion and gathers house keeping data.

Communication board plays the roll of communication with the earth station. This subsystem has two transmitters (one for FM, the

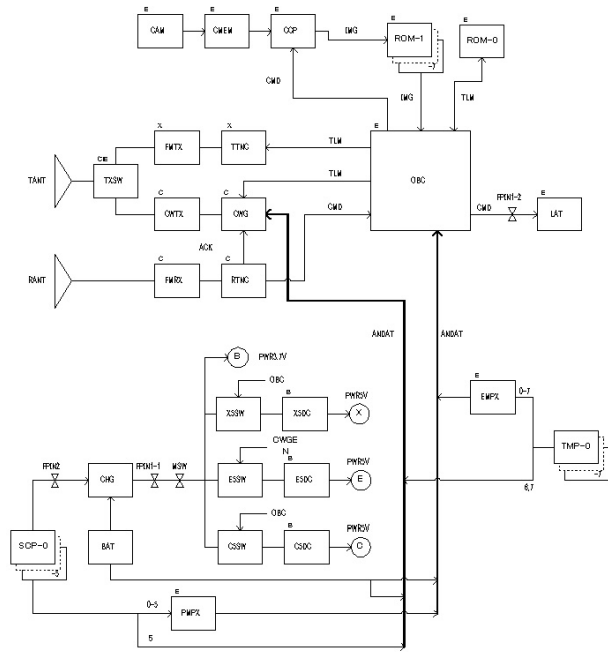

Figure 5: System Diagram of XI satellite

other for CW) and one receiver. Each transmitter/receiver has a encoding/decoding processor, which interfaces between OBC and transmitter/receiver. Communication subsystem runs independently of OBC subsystem, so that communication can be conducted even in the case of OBC malfunction.

Power board consists of a charge circuit and three step-up DC-DC converters. XI has 8 lithium ion batteries connected in parallel, which are rechargeable from solar cells via this charge circuit. Three DC-DC converters supplies 5V to OBC subsystem, receiver/CW transmitter subsystem and FM transmitter subsystem, respectively.

5.2 Fault Tolerance Feature

XI features cross-check type redundancy against internal circuit malfunction. Because CubeSat is so small, it cannot have a general type of redundant system such as voting system, stand-by redundancy system, etc. The voting system is not acceptable also because the judgement unit becomes a single failure point and so the unit must be space rated.

On the other hand, the fault tolerance system adopted in XI can be realized only with non-space rated COTS parts, and doesn't require much spatial resource.

XI has three power lines which drive OBC board, RX/CW TX(receiver/CW transmitter) and

FMTX(FM transmitter), respectively. OBC monitors the current of RX/CWTX power line and can reset it, whereas a processor of RX/CWTX monitors the current of OBC board and can reset it. FMTX is nominally off and is activated only when OBC requests FMTX to send the telemetry data.

OBC resets RX/CWTX line at certain intervals. RX/CWTX power is also cut off when excess current is detected. RX/CWTX resets OBC when commanded from the ground station or an excess current is detected by RX/CWTX.

Each reset circuit has two signal lines, and only the combination of high for one line and low for the other triggers the reset operation. This design reduces the possibility of unintended reset command from a processor in failure.

XI can be operated or monitored by ground station even when one of three power systems is down. RX/CWTX system can receive commands from ground station and send beacon even if OBC stops. RX/CWTX power line malfunction is minimized by a bypass circuit which put the battery power directly into RX/CWTX in case of the DC-DC converter malfunction.

5.3 Mission Sequence

CubeSats are activated when released from P-POD, which is detected by the microswitch at the bottom corner of the structure. After a certain stand-by intervals, XI deploys antennae and starts beacon transmission automatically.

In the nominal operation mode, XI transmits beacon signals at 80mW, records house keeping data, and standby for the command reception. FM transmitter is activated as a reaction to the command uplink, and its output power is fixed at 0.8W. Camera is activated by both an internal timer and uplink command.

6 Subsystems

6.1 OBC & Electronics

This subsystem consists of micro processor (PIC16LF877, 4MHz, 10mW), EEPROM (256kbit \times 8) and camera unit.

The main processor (OBC), Microchip PIC16LF877, is selected from COTS products and is not radiation-hardened. Single event latchup (SEL) can be detected by measuring the current of the processor's power line. More than 10 times bigger current was measured when SEL occurred in the radiation test held at Japan Atomic Energy Research Institute (JAERI) and

NASDA. This current is to be detected and can be cut off by the receiver processor. Single event upset (SEU) probability is expected to be 2.4×10^{-5} /device/day for PIC16LF877. The in-circuit watch dog timer is used for protection against SEU.

All house keeping (HK) data and images are stored in 8 EEPROMs. HK data is stored in 1 EEPROM (32kbyte), while images are stored in the rest 7 EEPROMs. HK data include battery voltage, solar cells voltage and current, temperature at 8 points, load current and so on. There are 2 modes as to the HK data collection intervals. The first 10kbyte is for high frequency mode, in which HK data are collected every 5 seconds. The rest 22kbyte is for low frequency mode, collected in every 5 minutes. An attitude motion such as tumbling is expected to be measured in high frequency mode, whereas a trend along the orbital period can be measured in low frequency mode.

The camera unit consists of CMOS image sensor, First-in-first-out (FIFO) type field memory and camera control processor (CCP). The image sensor has 300,000 pixels, 16 bits per pixel, but image data is reduced down to 15,000 pixels and stored in EEPROM in 16bit RGB format by CCP. CCP is PIC16LF877 at 10MHz. When OBC turns on the power of camera unit, CCP controls image sensor to capture an image. The digital image data generated by the image sensor is stored in FIFO memory temporarily, and then read by CCP later in slow speed. CCP stores image data to EEPROM, and at the same time it evaluates the values of the captured image from the viewpoints of contrast, color and brightness. The capacity of storing 7 pictures is provided by EEPROM (224kbyte).

In addition to the normal one-shot capture command (stored command), XI is implemented "capture and evaluate" command. In this mode, the camera will continue capturing image at a certain instructed intervals until it gets a highly evaluated image. Because more than 500 packets are required to send down an image to the ground station and the direction of camera FOV is uncertain, this on-board autonomous judgement will be helpful to easily get images with something, such as the earth, MPA or the other CubeSats.

6.2 Communication

XI has two transmitters and one receiver, which are custom-made by a Japanese radio maker. FMTX is for telemetry downlink, encoded in AFSK packet, at the speed of 1200bps. This transmitter consumes 4W when active, and the RF output is 0.8W. CWTX is for beacon in Morse code. It consumes

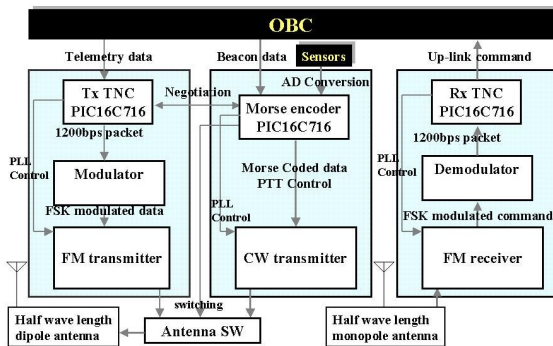

Figure 6: Communication System

475mW, while the RF output is 80mW. The uplink command is AFSK packet at 1200bps.

XI is equipped with 2 antennae, dipole antenna for downlink, monopole antenna for uplink. These antennae are selected because of their non-directivity characteristics. The dipole antenna is shared by FMTX and CWTX by using an analog switch. Basically CWTX has a priority of controlling this switch, but FMTX can override the control when the power of CWTX is down.

As encoder/decoder processors PIC16C716s are used. The decoder processor for receiver has a special roll of monitoring current of OBC and turned it off if excess current is detected. The Morse encoder executes A/D conversion to collect HK data by itself as well as receiving some data from OBC, so that OBC malfunction should be non-critical for the satellite.

The FMTX and its processor depend on OBC, because OBC turns on/off the power line of FM transmitter system. FM downlink is executed as a reaction to the command uplink. Figure 6 shows the diagram of the communication subsystem.

Antennae are latched using nylon wire while in the P-POD, and are deployed by cutting the wire by a NiCr heater.

The ground side equipment for communication is based on amateur radio equipment and PC. Two cross-Yagi antennae (430MHz band/144MHz band) and one ground plane antenna are operative at present in ISSL. The cross-Yagi antennae feature auto tracking by PC using *2-line* ephemeris data. An orbit determination software using Doppler shift history is being developed in order for the quick and independent acquisition of the satellite orbit.

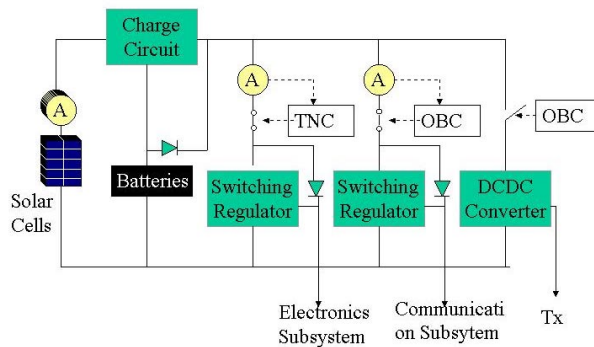

Figure 7: Power System

6.3 Power

Figure 7 shows the block diagram of the power system. Solar cells provide power to the loads and charge batteries during daylight, while batteries provide power during eclipse. Space rated mono-crystal silicon cells are selected and they cover all 6 surfaces of XI. They are connected in 10-series, 1-parallel, providing 4.5V, 1220mW at 80°C.

The battery is lithium-ion secondary battery, connected in 8-parallel. The characteristics of the selected battery is shown in Table 2. The total capacity of these batteries is 780mAH, which corresponds to 38 hours of operating duration without solar power. The battery charger is in-house developed, constant current constant voltage (CCCV) type circuit with pre-charge battery condition check.

As is mentioned in the previous sections, there are three independent power lines. All lines provide 5V, but 5W switching regulators are used for OBC line and CWTX/RX line, while a 6W DCDC converter is used for FMTX line. The regulation efficiency of these regulators is up to about 75%.

The power design is made so as to satisfy the following points;

- All components except FMTX can be directly driven by the solar cells.
- Power generation and consumption must be balanced in an orbital period.

The average depth of discharge (DOD) is estimated to be 2%. Figure 8 shows a power analysis at nominal operation.

Table 2: Battery Specs

Cathode Material	Lithium Manganate
Anode Material	Carbon
Voltage	3.8V
Capacity	780mAH

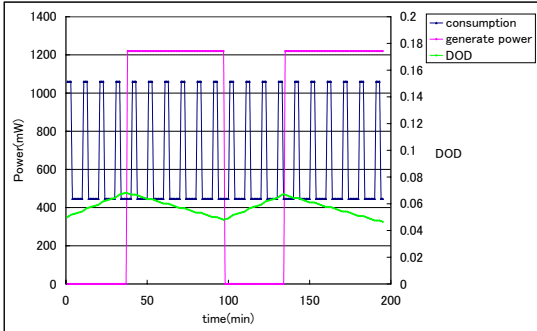

Figure 8: Power Analysis

6.4 Attitude Control

XI is adopted the along-magnetic field passive control using permanent magnet. This helps to make the satellite thermally uniform. A permanent magnet is put along the +Z axis (which runs vertically from the bottom to the top surface of the satellite.) The torque works so that the dipole of XI aligns the earth magnetic field, that means XI rotates twice per one orbital period and prevents the satellite from shined from one side. In addition, a hysteresis damper is equipped to dissipate the oscillating energy.

Table 3 shows the attitude control devices planned to be equipped in XI. The magnet is selected so as to generate more torque than the maximum expected perturbation torque on the orbit. The libration damper is designed to stabilize the satellite's attitude within a few days.

7 Management of CubeSat Project

Table 3: Attitude Control Devices

	Torquer	Damper
Material	Alnico5	50%Permaloy
Size	$\phi 4 \times 25\text{mm}$	$\phi 80 \times 0.3\text{mm}$
Weight	2g	10g

The CubeSat program started in the end of 1999, and we had made a conceptual design for the first 10 months. The actual development started in October 2000, when the launch vehicle and time were fixed. After that we have developed new models every 2 months which are BBM1, BBM2, EM and FM. BBM1,2 (Bread Board Model) is to establish key technologies and necessary skills. EM (Engineering Model) is for system validations and several kind of environmental testing. Now we are in FM (Flight Model) development phase and it will be completed by the end of October, 2001.

In addition to the model development, we have conducted the following testing to feed back their results to the design;

- Radiation testing to investigate single event characteristics of OBC candidates.
- Long-range communication test using balloon for transmitter/receiver evaluation and operation practice. (ISAS balloon, communication range: 400km)
- Antenna radiation pattern measurement to decide antenna configuration.
- Constant temperature oven test to investigate temperature range of each component.
- Thermal-vacuum testing.
- Vibration testing.

We have 20 active members for this project. As is mentioned in section 5.1, we have 6 subsystem groups. The students in the project are to belong to two groups, so that students should have broad knowledge of satellite development, and that they can take interface between the two groups they belong to. Almost all of the management such as design, test planning, development scheduling are performed by students. Through this project, students learn satellite systems and design, testing methods, peripheral knowledge and skills (electronics, materials, mechanics, etc.) and project management methodology. Some students perform research on design theory or intelligent computer-aided design taking advantage of this CubeSat project.

The total cost of developing XI satellite is \$100K, which includes initial equipment investment, several tests and launch cost. The cost of fabricating one flight model is about \$10K.

8 Conclusion

This paper describes the outline of University of Tokyo ISSL's CubeSat "XI" for the demonstration of pico-satellite bus technology, validation of

COTS parts in space, and for imaging mission using CMOS camera. XI will be launched together with other CubeSats in May, 2002 by Russian Dnepr.

Although XI is an extremely low cost satellite and positively uses non-space rated parts, it is designed to have a redundancy to survive in space environment.

CubeSat program is promoted primarily for space engineering education. The students manage the project and experience the whole cycle of satellite development from design until operation.

ISSL defines this project as a first step of obtaining intelligent and low cost small satellite technologies, and will make the most of the results of XI development and flight for the future satellite projects.

Acknowledgements

This paper is partly founded by Grants-in-Aid for Scientific Research of the Japan Society for the Promotion of Science and the Telecommunication Advancement Foundation.

References

1. Nobutada Sako, Shuichirou Ota, Yuichi Tsuda, Takashi Eishima, Toru Yamamoto, Ichirou Ikeda, Hiromitsu Ii, Hidenori Yamamoto, Hideyuki Tanaka, Akira Tanaka and Shinichi Nakasuka, "CanSat Suborbital Launch Experiment —University Educational Space Program Using Can Sized Pico-Satellite", Proceedings of the 51st International Astronautical Congress, IAF-00-P.1.04, 2000
2. Yuichi Tsuda, Nobutada Sako, Toru Yamamoto, Ichiro Ikeda, Takashi Eishima, Akira Tanaka and Shinichi Nakasuka, "Experiment of Membrane Deployment by Centrifugal Force Using Nano-Satellite "CubeSat", Proceedings of the 44th Space Sciences and Technology Conference, 00-3E7, 2000 (Japanese)
3. www.space.t.u-tokyo.ac.jp/cubesat/index-e.html
4. www.calpoly.edu/aero/polysat/
5. www.oss.com/
6. www.kosmotras.ru/