

ENCOUNTER 2001: SAILING TO THE STARS

James Rogan (Encounter 2001, LLC), Paul Gloyer (AeroAstro, Inc.)
 Joel Pedlikin (AeroAstro, Inc.), Gordon Veal (L'Garde, Inc.)
 Billy Derbes (L'Garde, Inc.)

ABSTRACT

Encounter 2001, LLC, AeroAstro, Inc., and L'Garde, Inc. are funded and developing a revolutionary spacecraft for a 2003 launch. The mission of this launch is the delivery of a three-kilogram payload out of the solar system using a solar sail. While the benefits of using solar sails for long-duration missions have been discussed extensively, to date no solar sail missions have been executed. Using a base material one-seventy-sixth the thickness of a human hair, the Encounter solar sail will be 75 m by 75 m with a mass of 18 kg (including payload), resulting in an areal density (mass per unit area) at least 3 times lower than any other sail seriously proposed. Areal density is the most common metric used for measuring solar sail performance: the lower the areal density the more delta-V a sail can provide a payload. Thus, this high-performance sail design represents a major advance in space propulsion enabling missions to the outer solar system that are virtually impossible with existing technology.

The spacecraft is well into the preliminary design phase, and it is anticipated that it will be launched as a secondary payload on the Ariane 5 vehicle in the last quarter of 2003. This spacecraft will consist of two parts: the Carrier, which transports the sail outside of Earth's gravity well, and the Sailcraft which transports its 3 kg payload beyond the solar gravity well. The carrier is based on the AeroAstro Bitsy™ kernel. The stowed sail will deploy using inflatable boom technology currently being developed by L'Garde. The sail payload will consist of messages, drawings, photographs, and DNA signatures of 3 to 5 million human participants.

1.0 INTRODUCTION

The Team Encounter mission is to deliver a 3 kg payload to solar escape velocity at a total mission cost of less than 20 million dollars. The development team consists of AeroAstro, L'Garde, and Encounter 2001. The spacecraft consists of 2 stages:

- (1) The carrier, with the necessary propulsion, power generation, avionics and imaging systems to deploy and image the sail outside of earth orbit.
- (2) The sailcraft, consisting of the sail, control system, and power generation required to transport the 3 kg payload out of the solar system.

Encounter 2001 provides overall program management and funding, L'Garde provides the solar sail and its self rigidizing booms and AeroAstro provides the carrier, electronic components of the sailcraft, and the overall systems engineering and integration (SE&I). The currently planned launch solution is the Ariane 5 micro-ASAP secondary launch slot. This mission design is the result of the conceptual design phase completed by the team in November of 2000. During this phase, the team reached the conclusion that a 76 m x 76 m solar sail could be built and launched at achievable cost, reach solar escape velocity in 1.9 years, and leave our solar system in approximately 14 years.

Recognizing the value of independent oversight engineering, Team Encounter engaged Space Analytics Associates to review the results and conclusions of the conceptual design. Their review verified the trajectory analysis, the selection of a solar sail as the method of propulsion, the trajectory analysis, the basic control philosophy, and the cost range. Risk areas were also determined. These results were factored in to the plan for the preliminary design effort, which is now underway.

The following sections discuss the results of the conceptual design phase and describe the overall mission strategy, spacecraft, sailcraft design, and the schedule to flight.

2.0 MISSION REQUIREMENTS

The top-level mission requirements are the delivery of a 3 kg payload to solar escape velocity within a prescribed budget while generating maximum revenue. Key elements to generating this revenue include streaming of images of the sail deployment to the Internet and visual recognition of logos on the sail. Thus, the conceptual design provides for delivery of a 3kg payload to solar escape velocity in 1.9 years, 4 commercial logo zones on the sail and nine Carrier cameras for imaging sail operations for an estimated cost of \$16 to \$19 million.

MISSION PHASES

- **Solar sailing**
 - First 300 days, “jibbing” away from the sun
 - Reorient
 - Escape velocity in 1.9 yrs

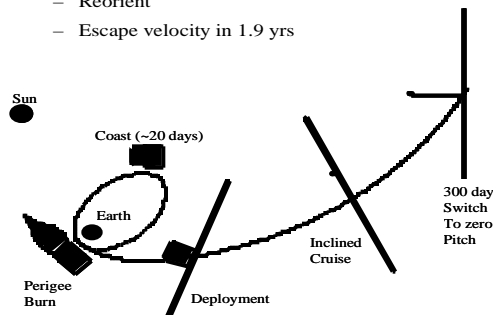

Figure 2-1 Mission Phases

The planned mission profile is as follows:

- Launch to GTO as an Ariane secondary payload
- Coast/system checkout
- Spin up and motor burn at perigee to achieve Earth escape velocity
- Despin
- Boom inflation, rigidization, verification
- Vent Booms
- Release Sail
- Observe sail and stream images to the Internet
- Carrier drifts (potential secondary missions)
- Sailcraft accelerates to solar escape velocity

These operations are depicted in Figure 2-1. Figure 2-2 illustrates the Encounter vehicle's passage through our solar system.

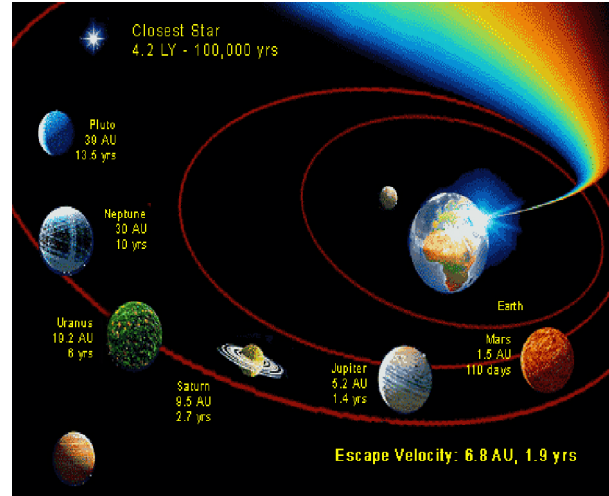

Figure 2-2 Planet Passage

3.0 SPACECRAFT DESIGN

The Encounter 2001 spacecraft is a two-stage vehicle. (See Figure 3-1) The first stage, the ‘carrier,’ is a fairly standard spacecraft with the usual subsystems: ACDS, power, C&DH, TT&C, propulsion, etc. The carrier’s main mission is to get the second stage out of earth orbit. This second stage, the sailcraft, is as far from ‘standard’ as a spacecraft has ever been. It consists of a 76 m. x 76 m. solar sail with passive and active attitude control systems, a power generation and regulation system, and a 3 kg payload. The mass split of the stages is carrier 84.9 kg and sailcraft 19 kg.

AeroAstro and Encounter 2001 performed extensive trade studies before arriving at this approach. We examined numerous conventional and unconventional propulsion technologies and multiple gravity assist trajectory options. Despite the development risks, we reached the conclusion that no other mission concept could place 3-5 kg of payload on an interstellar trajectory within the cost and schedule limitations of this project.

The Encounter spacecraft will be launched as a micro-ASAP secondary payload on an Ariane 5. The launch vehicle will release the spacecraft into a Geosynchronous Transfer Orbit (GTO).

The combined spacecraft will remain in GTO for approximately 2-4 weeks, depending on launch date. The primary reason for the delay is the possible need to wait for the moon to orbit out of the spacecraft’s planned trajectory. The time will also be used to check out the spacecraft’s functions and practice streaming images live to the Internet.

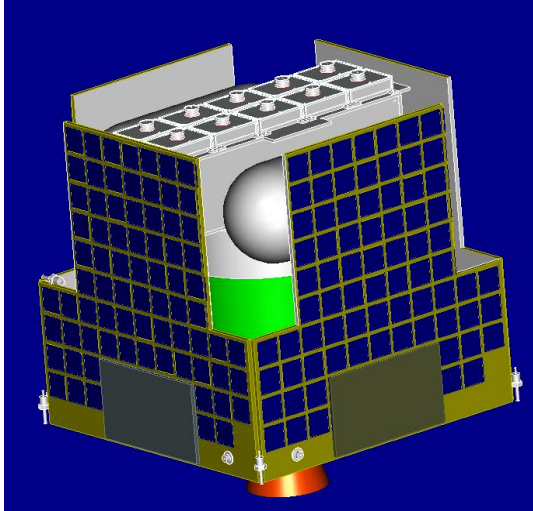

Figure 3-1 Encounter Spacecraft

After 2-4 weeks, the carrier will use nitrogen gas jets to point the combined vehicle parallel to the perigee velocity direction, and spin it up to 44 RPM. At the next perigee, a Star 12g solid rocket motor will fire with sufficient Delta-V (approx. 750 meters/second) that the spacecraft escapes Earth orbit.

After a brief coast, the carrier will despin the spacecraft and align it with the Sun for solar sail deployment. First, one pair of opposing inflatable booms will extend to their maximum length. Then, the second pair of orthogonal booms will extend, fully unfolding the sail. The booms will be made of a material that rigidizes when it cools below a set temperature, and are designed to cool when deployed. Thus, the spacecraft will coast for approximately another hour while the booms cool and rigidizes. Note that the booms incorporate heaters, so if the booms do not deploy properly the first time, they can be vented, heated/softened, and re-inflated. Next, the inflation gas will be slowly and symmetrically vented out of the booms.

Once the deployment phase is complete, the sail will separate from the carrier. (At this stage, the combined vehicle will be approximately 64,000 km from the Earth.) As the sail pulls away from the carrier, ground controllers will command a suite of 9 or fewer color cameras to start sending images back to the Earth for immediate streaming to Encounter 2001's website. We expect to beam back live images for at least 20-30 minutes, before the sail is out of view.

Details of the sailcraft design are in section 3.2 of this paper. The sailcraft is designed to be entirely autonomous, using a combination of passive and simple active stabilization techniques to stay on course. If all

goes according to plan, the sail (and its payload of 3-5,000,000 participants' writings and DNA) will reach solar escape trajectory within 1.9 years after release. By the time it passes Pluto, it will be the 2nd fastest object ever built by man.

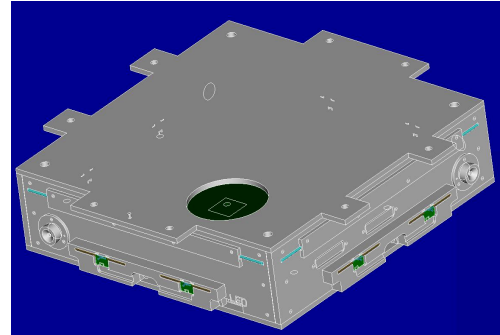

Figure 3-2 Bitsy Kernel

3.1 CARRIER DESIGN

The Encounter Carrier is built around AeroAstro's Bitsy spacecraft kernel (see Figure 3-2). This simple nanosatellite core is scheduled to be launched as part of the SPASE mission as a Shuttle Hitchhiker payload in November of 2001. Bitsy is designed to provide the minimum complement of capabilities any microspacecraft would require, as well as interfaces for adding any additional capabilities required. It includes basic Command and Data Handling Electronics, Power Control and Regulation Electronics, and a set of Lithium-Ion rechargeable batteries. The kernel also contains multiple serial interfaces for TT&C, payload control and data collection, ACDS sensors, etc., as well as interfaces for up to 12 solar panels and 6 additional primary or secondary battery strings. The Encounter carrier will use nearly all of those interfaces.

The carrier is not designed to be autonomous. Virtually all command and control of the spacecraft will be accomplished from the ground in real-time. The brevity of the mission (~30 days) makes this both economical and practical. United Space Networks' worldwide array of 13-meter ground stations and custom control software will be used to command the spacecraft and receive data from it.

The carrier's primary structure consists of a simple 6061 aluminum frame with the various subsystem components mounted to it (See Figure 3-3). Carrier size is approximately 58 cm x 58 cm x 55 cm. The majority of the carrier's volume is occupied by a Thiokol Star 12g solid motor, which is used to propel the combined spacecraft out of earth orbit. Depending on the final

mass of the spacecraft, 5-10% of the Star's standard propellant load may be removed for this mission.

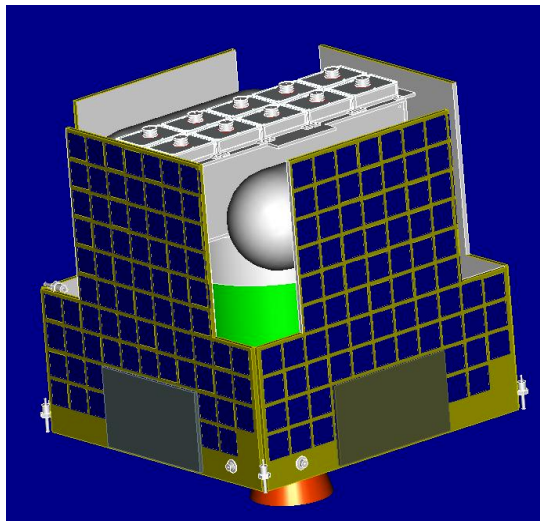

Figure 3-3 Encounter Carrier

Spacecraft power is generated by 5 body-mounted silicon solar panels provided by Kyocera. The panels use rugged, "terrestrial" quality silicon cells identical to the type being flown with Bitsy off the Shuttle in November 2001. The panels are sized and placed such that they supply sufficient power for all core spacecraft functions (C&DH, TT&C, and ACDS) in almost any spacecraft orientation. In other words, if the spacecraft somehow winds up in a random tumble, it will have enough power to communicate with the ground, determine its orientation, and restablize. Additional energy is stored in a set of lithium-ion batteries identical in design to those being flown on Bitsy in 2001. These batteries consist of 10 packs of 4 industrial grade Li-Ion cells, packaged, matched, and tested for use in space. The panels provide sufficient power for all phases of the mission except the last 15-30 minutes, when the carrier images the departing sail. The remaining energy in the batteries can supplement the solar panels for those 15-30 minutes, allowing all the cameras, cold gas thrusters, and radio to be operated simultaneously. Alternatively, Lockheed-Martin and AFRL have offered to supply the mission with two experimental deployable solar arrays. If the arrays are carried, they can be deployed to generate substantial additional power during the last phase of the carrier's operation.

Thermal regulation on the carrier will be achieved via a carefully designed passive system using MLI blankets and various emissive coatings. Some small heaters will also be included to keep components warm in GTO apogee and outside earth orbit.

The spacecraft will communicate with the ground via an L3 S-band transponder and 2 omni-directional patch antennae. Uplink data rate is 9600 bits/sec and downlink is 64000 bits/sec.

A nitrogen cold-gas system is used for all spin-up, spin-down, and pointing maneuvers. The nitrogen, stored in two cylindrical tanks at about 4000 PSI, is used for both control maneuvers and for inflating the sail booms before release. Six small thruster/valve assemblies allow all necessary torques to be generated. AeroAstro-manufactured coarse and medium sun sensors provide one vector of attitude determination. While the spacecraft is in earth orbit and spinning, an Ithaco Horizon Crossing Indicator provides the necessary 2nd vector for attitude determination. Once the spacecraft has left earth orbit, an Encounter/AeroAstro-developed CMOS-based star camera must be used to obtain the 2nd vector once the spacecraft is spinning slower than 4 RPM. The star camera cannot provide this vector when the carrier is spinning faster than 4 RPM, and the HCI cannot provide the vector once the spacecraft is outside of earth orbit, hence the need for two different sensors.

The star camera will be less than 1/10 the size and mass of any other available star camera, and draw less than 1/10 the power. Its accuracy will be about one degree lower than a typical star camera, however, this accuracy is more than enough for this mission. Note that, as described in section 3.2, a duplicate of this sensor will fly on and provide yaw angles to the solar sail. As part of AeroAstro's and Encounter's ongoing cooperative development efforts, the CMOS imager at the core of this star camera is being test-flown on the SPASE Bitsy Shuttle Hitchhiker mission in November of 2001. This test will establish that the star camera can work in a space environment and provide sample star images for use in camera algorithm development.

The carrier's critical payload is a suite of 9 industrial-grade commercial color CCD cameras. Each camera has a different focal length and lens which will allow the carrier to take images of the sail at a wide range of distances. The cameras will be used to take images of the sail deploying and flying away at 2 different frame rates. The slower frames will be beamed back to Earth for streaming live via the Internet. The faster, near-video-quality frames will be stored onboard in 1 Gigabyte of DRAM for transmission back to the Earth over a greater time interval once the sail is out of sight. Team Encounter is performing trade studies comparing a single camera with a pan and zoom capability to the set of 9-10 with fixed lenses. Regardless of which camera is carried, a commercial image compression

scheme such as MPEG-2 will be used on all image data to increase available frame rates.

It is conceivable that at the end of its primary mission the carrier will still contain sufficient nitrogen gas to function a few months longer. Team Encounter is exploring this possibility and considering allocating room for secondary instruments or experiments that could take advantage of this capability.

3.2 SAILCRAFT DESIGN

The sailcraft conceptual design developed for the Encounter 2001 mission is shown deployed in Figure 3-4 and packaged in Figure 3-5. The sail parameters are summarized in Table 3-1. The complete spacecraft must be packaged within a 60 cm x 60 cm x 71 cm volume to fit within the constraints of a secondary payload on an Ariane 5 launch vehicle.

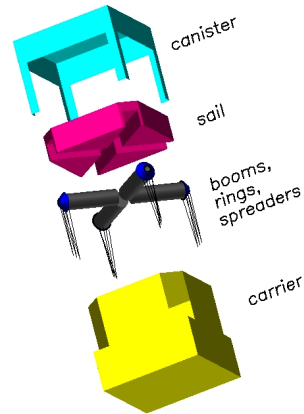
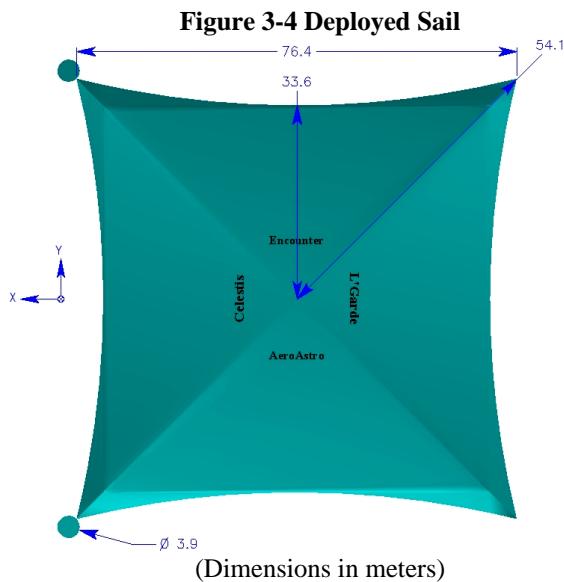

Figure 3-5 Packaged Sailcraft

TABLE 3.2-1 SAIL PARAMETERS

Surface Area	4907	m ²
Effective Propulsive Area	4797	m ²
Mass/Effective Propulsive Area	3.33	g/ m ²
Lightness Factor@beta=0°	0.411	
Tab Angle	5.2	°
Sail Substrate Thickness	0.9	µm
Isotensoid Stress	6895	Pa
Frontside Metallization	300	Å (Al)
Total Reflectivity "Rp"	78%	
Backside Metallization	200	Å (Cr)
Operational 1 AU Temperature	-38	°C
Boom Base, Tip Diameters	9.5, 3.5	cm
Average Boom Linear Density	14.1	g/ m
Boom Compressive Load	1.7	N
Boom Modulus	13,7900	MPa
Minimum Structural Safety Factor	4.2	
Tip Vane mass, ea.	118	g

Once the combined spacecraft is on orbit and positioned by the carrier vehicle, the canister is discarded and the sail is deployed over a one-hour period of time. Deployment is accomplished by inflating the conical telescopically packaged booms. As the booms deploy, the sail is unfolded and deployed. This method of boom packaging was chosen because it provides precise deployment control with no additional mass. The booms are kept warm during deployment by a small

infrared heater at the base of each boom. Once the boom is deployed, the heaters are turned off to allow the boom's laminate resin to cool below its glass transition temperature. Rigidization is expected to take approximately 30 minutes. At this point the sail is completely deployed and the sailcraft is separated from the carrier.

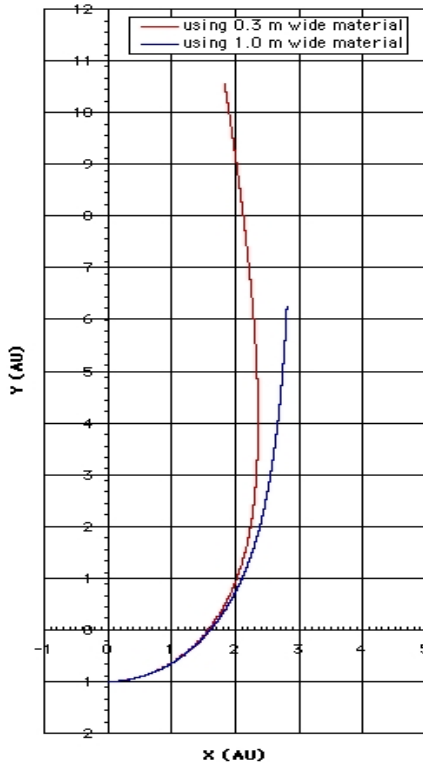

Figure 3-6 Sailcraft Trajectories

The sailcraft is required to achieve solar system escape (in any direction) within 3 to 5 years. To achieve this, the sailcraft must achieve a lightness factor (measure of the fraction of solar gravity offset by solar pressure forces when the sail is normal to the Sun's rays) of greater than 0.38, an areal density of less than 3.5 g/in², and reflectivity greater than 90%.

The sailcraft escape trajectory (Fig. 3-6) is achieved by giving the sail a trim angle of 25° with respect to the Sun. The sail is passively stabilized in the pitch and roll axes by use of "tabs". Simply bending the sail booms such that the sail is bent away from the Sun around its periphery develops the "tabs" (Fig. 3-7).

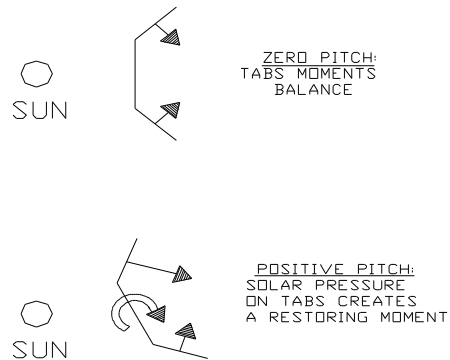

Figure 3-7 Passive Stabilization

The 25° trim angle is maintained by locating the 3.0 kg payload away from the center of the sail. This in turn moves the sailcraft center of mass away from the center of pressure. After 300 days the sailcraft velocity direction is essentially radially away from the Sun. To take advantage of this, the payload mass will be moved to the center of the sail, bringing the sail to a zero degree trim angle. As a result, the sail will thrust directly away from the Sun, i.e. the new thrust vector will be aligned to the existing velocity vector. Thus, the sail can make maximum use of the solar pressure to increase sail velocity.

While the sailcraft is passively stabilized about the pitch and roll axes, the yaw axis is not. It is not possible to passively stabilize the sail about the yaw axis; instead, it is necessary to provide active yaw control via vanes at the tips of two of the booms. These yaw control vanes are 3.9 m in diameter. (See Figure 3-4) An onboard yaw sensor/star camera measures the sailcraft orientation relative to a fixed star field. When the sensor detects a yaw error, a command is sent to the yaw vane actuators (paraffin rotary actuators) to rotate the vanes and null out the yaw error. Yaw control will be discontinued after the 300-day maneuver, because the pitch angle is zero degrees after that point, making yaw angle irrelevant to the sail's thrust direction. (See Figure 2-1)

3.2.1 SAIL

Two conceptual sail designs were carried out, one using 1 meter wide sail material (Option A), the other using 0.3 m wide material (Option B). The 0.3 m wide material is more readily available, but it adds to system mass due to extra seam tapes and adhesives, and it has lower average specularly, described as "propulsive reflectivity" R_p , because the added seams are more wrinkled than the sail field.

Periodic Follower Loading of the Sail Booms

The sail is designed to keep the membrane stretched taut and relatively wrinkle free under a 6895 Pa (1 psi) load. This load induces a 1.7 Nt compressive load in the sail booms, which is easily resisted by short cylinder buckling capability of the tube. The long-column-buckling problem is mitigated by attaching the sail to the boom periodically along the boom length via rings.

The long column (Euler) buckling of a cylinder with low-end fixity is:

$$\text{Euler Buckling Load} = \frac{\pi^2 EI}{L^2}$$

$I = \frac{\pi r^4}{4}$
 $E = \text{modulus}$
 $L = \text{length}$
 $t = \text{thickness}$

There are 42 rings, so the potential improvement in buckling load is a factor of $41^2 = 1681$. This makes the very low mass requirement (~14 g/m) achievable. Also, since P_{euler} is a function of the squares of both n and L , this load does not decrease for longer booms if more rings are added. Thus, the design is scalable. The telescopic boom is tapered, requiring closer spacing of sail attach points (rings) near the boom tip.

Out of Plane Stiffening

The solar pressure is very small, but stiffening is still required out-of-plane to resist it. The ring spreader system increases EI to greater than 2200 Nt-m². This minimizes boom bending and the loading moment increase due to curvature while under compression. It also increases boom natural frequency, easing the difficulty of attitude control.

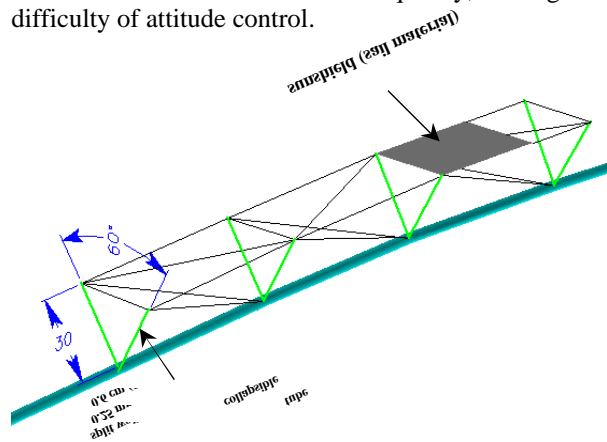

Figure 3-8A Spreaders and Rings

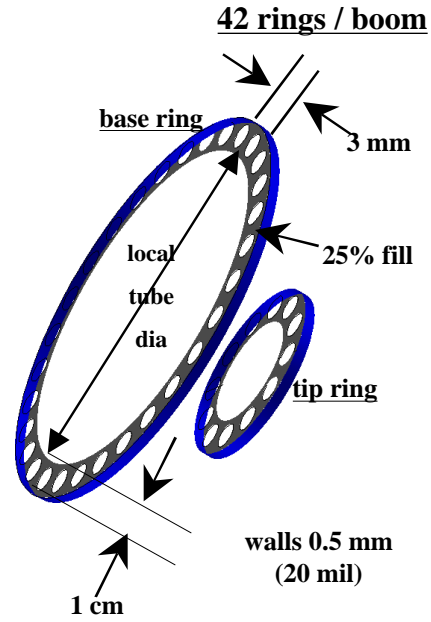

Figure 3-8B Spreaders and Rings

Extremely low boom mass/length is required (~14 g/m including spreader system) out of the range of all experience. Therefore, for conceptual design, isogrid construction was assumed as a configuration that could be practically analyzed. Note that L'Garde will build test booms as part of preliminary design.

The critical component in the boom structural mass is the composite tube. It bears all the compressive loads. Independent non-linear boom bend analyses were conducted to determine the loads and deflection. The design modulus of 13,790 MPa (2 Mpsi) is based on test data and is considered conservative.

The tube composite matrix rigidizes by cooling below its glass transition temperature (T_g) after deployment. Sub- T_g rigidization is reversible; therefore the flight booms can be tested for defect, stiffness, CTE, and deployment before flight. "Shape-memory" effects are also exhibited.

Boom Properties	
Base Diameter	9.5 cm
Tip Diameter	3 cm
Length	54.1 m

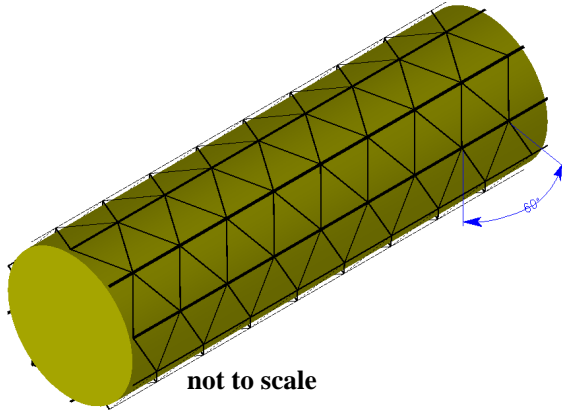

Figure 3-9 Sub-Tg Composite Isogrid Boom

Telescopic Boom Packaging/Controlled Deployment

Telescopic deployment is well tested and robust. The boom is tapered to package telescopically, making it more structurally efficient. Rings are fixed to the boom at the tops of folds. The sail is attached to the rings, so it goes along for the ride during boom deployment.

Deployment is controlled by its nature. The base segments deploy first. The pressure-stabilized base resists deployment tip-offs. This system does not add parasitic mass to control deployment.

We deploy one axis in both directions simultaneously, then the perpendicular axis. The inflation process can be halted as necessary. Previous deployment experience shows the importance of entrained gas - the short path length in telescopic packaging allows launch venting.

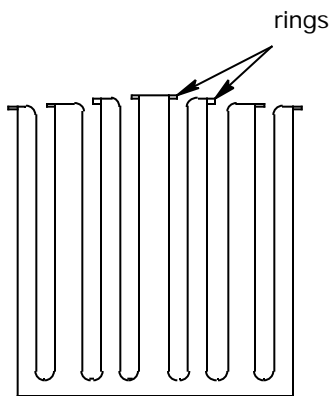

Figure 3-10 Boom Telescopic Packaging

Boom Rigidization Control

IR lamps (jettisoned later) assure the boom is warm and pliable for deployment. One layer of multi-layer insulation will chill the boom to well below its Tg once deployed. A sunshield on the spreader system adds an

extra layer of thermal protection. Thirty minutes are required to rigidize the booms once IR lamps are shut off. The boom insulation layer is necessary to reduce the thermal gradient from the hot to cold sides of the tube (and thus reduce any resulting bending), so this rigidization system adds no parasitic mass.

The IR light must be distributed along the bent boom from the base. The bladder is clear, the isogrid sparsely filled, and the insulation layer metallized on the inside. Internal reflection bounces IR light around the corners.

Structural Efficiency and Mass Ranges

The resultant structural efficiency of the boom is depicted in Figure 3-11. The Euler loading parameter "c" ($\sim n^2$ for periodic follower load) is not represented on either axis.

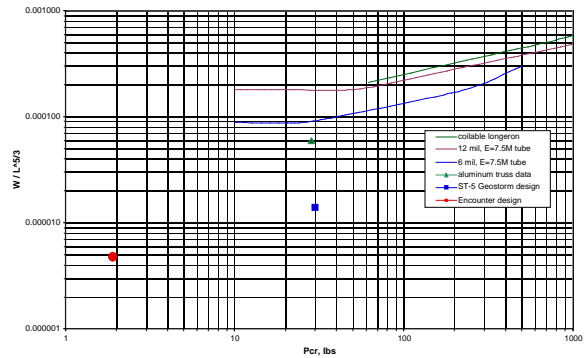
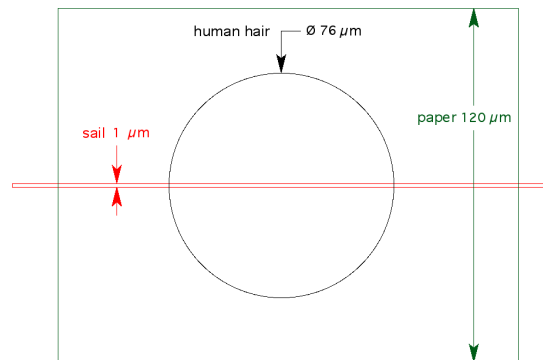

Figure 3-11 Boom Structural Efficiency

Sail Material

The sail material is the thinnest available to meet the mass goal: 0.9 μm . Aluminum metallization was chosen for frontside because of its low mass and high reflectivity ($r = 90\%$). The backside chromium gives high emissivity to control sail temperature. It is also necessary for charge dissipation, anti-curl, and anti-blocking.



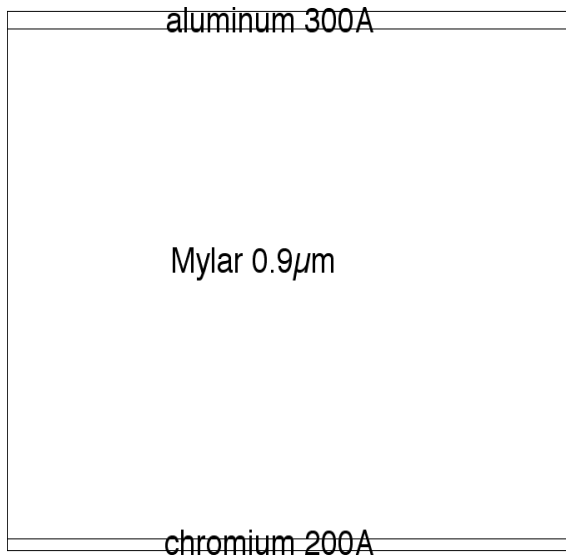

Figure 3-12 Sail Substrate and Metallization

Seams & Rip Termination

Very thin adhesive, 2.6 μm (0.1 mil), was developed for the seam tapes to keep parasitic mass down. The seam tapes are a narrow 0.8 cm. Cross rip tape is added to prevent rips along the length of a gore.

Potential rip sources are:

- handling, which one patches
- deployment snags, which are mitigated by the benign deployment design
- micrometeoroids, for which tests show no rip propagation.

However, once a rip starts in a thin material, it can propagate easily. A rip will turn at a seam and continue if not terminated, and it can turn 90° corners as well. L'Garde has developed rip terminators which stop a rip by turning it around on itself. This limits the rip impact to a 1 m X 10 cm max "flap".

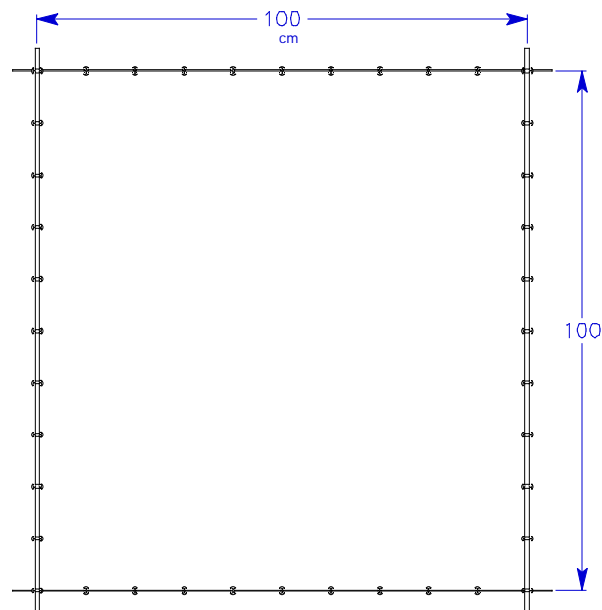
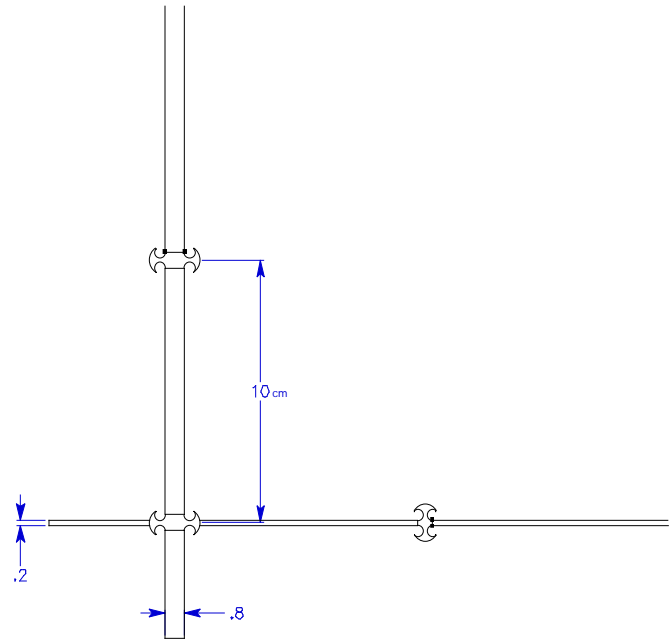

Figure 3-13 Seams and Rip Termination

Total and Propulsive Reflectivities

The reflective efficiency of the sail is given by total reflectivity "r" and propulsive reflectivity "Rp".

The total reflectivity is the total percentage of incident light reflected in any direction. It is a strong function of the metallization used, in this case aluminum (r = 90%). It can be affected by a deep wrinkle, if the light bounces off the material twice, absorbing 10% each time. However, test data shows that even heavily wrinkled material retains 88% reflectivity under zero

psi stress.

Stress wrinkles are avoided by the catenary system, which places the sail in isotensoid stress. However, material wrinkles are inevitable at the low film stress levels dictated by the gossamer structural design. Propulsive reflectivity is a measure of the effect of scattering on propulsion due to wrinkles. It is a more appropriate concept than 'specularity'.

Optics-based reflectivity models assume symmetry about the surface normal beyond $\pm 6^\circ$ - 10° with a perturbed Lambertian distribution. However, optics is concerned with achieving a nicely specular reflection; scattered photons are treated as not useful. A solar sail, on the other hand, can use those scattered photons for propulsion. L'Garde has data that shows high symmetry about the specular reflection line, so we assume this symmetry to evaluate R_p . All reflected force components normal to the specular reflection line cancel, leaving:

$$R_p = r_n \cos(Q_n)$$

$$r_n = \% \text{ incident light reflected in annular region } n$$

$$Q_n = \text{angle of region } n \text{ off specular reflection line}$$

The fold lines and seams are much more wrinkled than the sail field, so samples from the three zones (field, folding crease, seam) were tested and their results area-weighted to come up with propulsive reflectivity estimates for the sail.

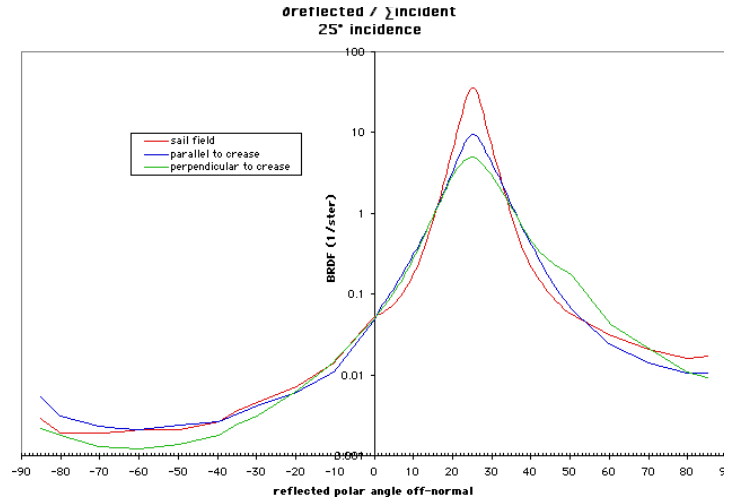
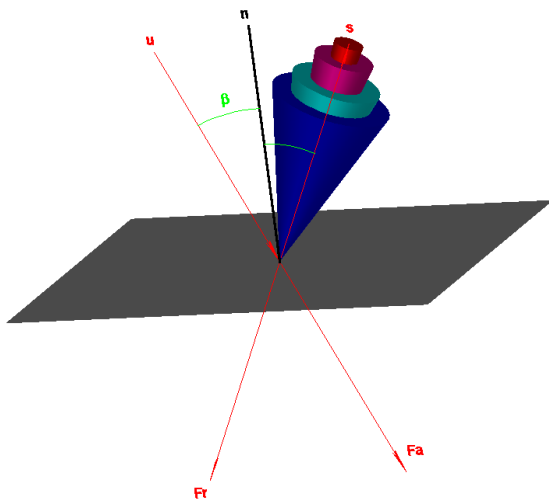

Figure 3-14 Scattering Data and Symmetry Model

3.2.2 SAILCRAFT CONTROL APPROACH

A combination of passive and active techniques are used to stabilize and control the orientation, and hence the performance of the Team Encounter solar sail. Dynamic stability is achieved in the pitch and roll axes through the use of passive tabs along the outer edges of the main sail. In addition to this passive stability, the solar sail incorporates two methods of active control. A pair of control tabs, located on the tips of two booms, is used to provide yaw angle control. To provide the necessary pitch angle control, the Encounter sail craft is equipped with a non-reversible, bi-modal center of mass control system.

For reference, the Sailcraft coordinates are established to be similar to aircraft coordinates with the Sun in the "down" direction.

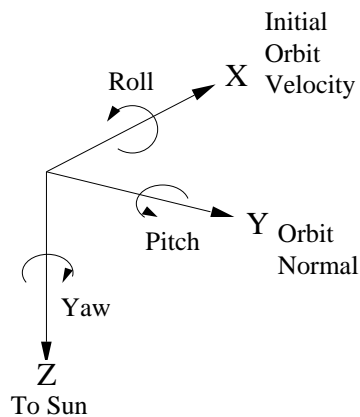

Figure 3-15 Sailcraft Reference Coordinates

The Sailcraft will achieve passive stability in the Pitch and Roll axes through the use of trim tabs on the edges of the mainsail. These trim tabs shift the center of pressure aft (anti-Sun) of the center of mass, providing a restoring torque against disturbances, as shown in Figure 3-16. The bent tips of the Sailcraft booms form the Pitch and Roll trim tabs by angling the outer edge of the mainsail away from the Sun.

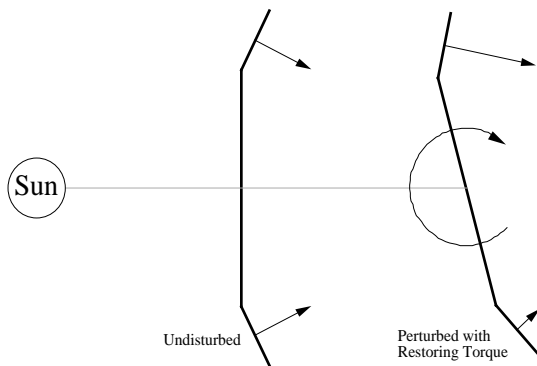

Figure 3-16 Sailcraft Pitch and Roll Passive Stabilization Technique

While it is desirable to achieve passive stability in all three axes, the nature of sunlight provides no reference or bias in the Yaw direction (rotation around the Sail-sun line). Theoretically, the best that could be achieved is neutral stability. In reality, imperfections in the sail surface and angular momentum transfer to the highest inertia axis, producing a non-zero Yaw rate. When the sail is flying at zero Pitch and Roll angles in the later phase of the mission, this is not an issue. However, for an inclined sail orientation such as that used by the Sailcraft in the first 300 days, an uncontrolled yaw

angle will alternately add and subtract energy to the orbit and result in greatly reduced performance. Since the Sailcraft needs the additional 40% performance provided by the inclined sail approach, the Sailcraft must incorporate active control of the yaw angle during the first 300 days.

Yaw Control System

The Sailcraft is equipped with a Yaw Control System capable of maintaining the Sailcraft yaw angle to within 5 deg for at least 300 days. A schematic of the Yaw Control System is shown in Figure 3-17, which identifies the pieces of the Yaw Control System. The major pieces of this system are discussed below.

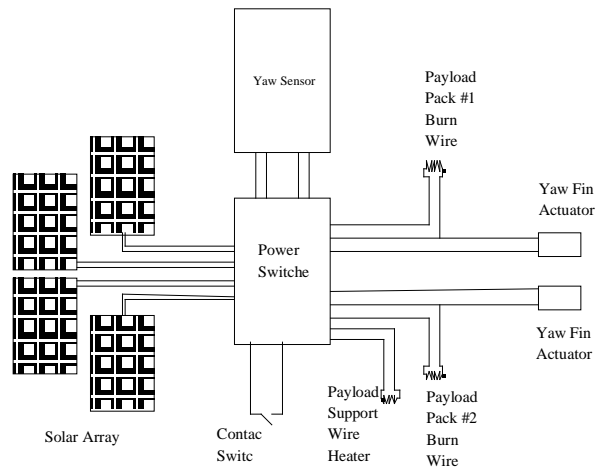

Figure 3-17 Yaw Control System Schematic

Four solar array panels located in the center of the Sailcraft will supply power to the Yaw Control System. These four panels, with a total area of 3.1 m², consist of thin film solar cells (CIGS) mounted directly to the thin film of the centermost portion (3 x 3 m area) of the Sailcraft. To save mass, cover glass will not be used on the solar arrays. This should be acceptable, given the rapid pace of the Sailcraft out of the solar system and the extreme care needed in handling the ultra-thin film of the Main Sail. While the Yaw Control System needs only 15 W of power, the solar array generates over 210 W of power at earth in order to provide sufficient power for the first phase of the mission, as shown in Figure 3-18. After 300 days, the Yaw Control System no longer needs to function, since the trajectory is insensitive to yaw angle when pitch and roll angles are zero.

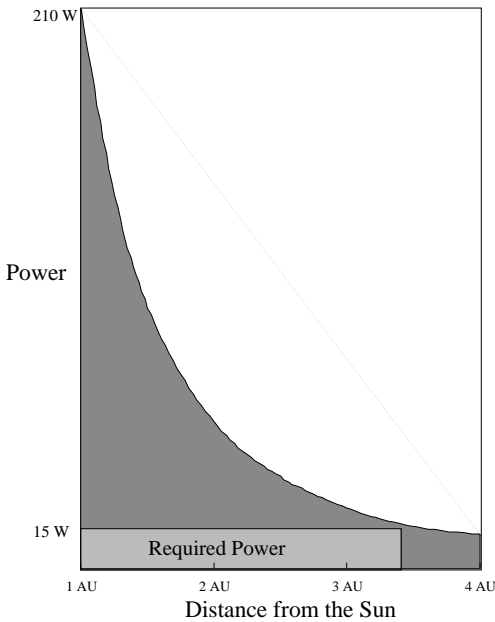

Figure 3-18 Sailcraft Power Profile

The solar array power flows through a Power Switching box, which routes the power to where it is needed on the Sailcraft. Excess power is shed via cell heating from open solar array circuits. The Power Switching box includes timer and contact switch circuits to control the activation of the Sailcraft burn wire systems and prevent early manipulation of the Yaw Fins. The Yaw Sensor provides primary control of the Power Switcher box.

The Yaw Sensor is a small CMOS camera, 2 x 3 x 3 inches, which determines the Sailcraft orientation with respect to the stars. While not a traditional star camera, this Yaw Sensor images the star field and compares it to a 100 star catalog to determine the Sailcraft yaw angle relative to the reference star field. Based on this information, the Power Switching box is directed to apply power to the yaw control actuators.

These actuators are located on the tips of two of the Sailcraft booms and form a rotational joint between the Yaw Fins and the Main Sail. When powered, the high output paraffin rotary actuators turn the Yaw Fins to produce the necessary yaw torque on the Sailcraft. The 10 cm thick by 1.5 cm diameter actuators are designed to provide 0-60° of rotation with a spring return, and are stowed within the respective boom for launch. The Yaw Fins are formed from an inflatable isogrid torus that supports a four-meter diameter disk of Main Sail film, which also stows within the boom for launch.

Pitch Control System

The mission profile requires two modes of Pitch angle operation. Initially, the Sailcraft will operate at a 25 deg Pitch angle, and then switch to a zero degree Pitch angle after 300 days. To achieve this bi-modal capability, the Sailcraft will use center of mass (c.g.) location to control the Pitch angle. By offsetting the c.g. to one side, the Pitch trim tabs will stabilize the Sailcraft at a 25 deg Pitch angle. When the c.g. is restored to the center, the Sailcraft will stabilize at a zero degree Pitch angle.

To achieve the necessary c.g. shift, the Sailcraft payload will be suspended from the center of the Sailcraft via a wire. In the initial orientation, the payload will be tied to the side with a burnwire, which holds it to the boom spreader system as shown in Figure 3-19. When the on-board timer reaches 300 days, it will power the burnwire to release the payload. With the payload restrained by only the suspension wire, it will fall away from the Sailcraft. To damp the suspension wire oscillation, the wire will be designed to plastically deform.

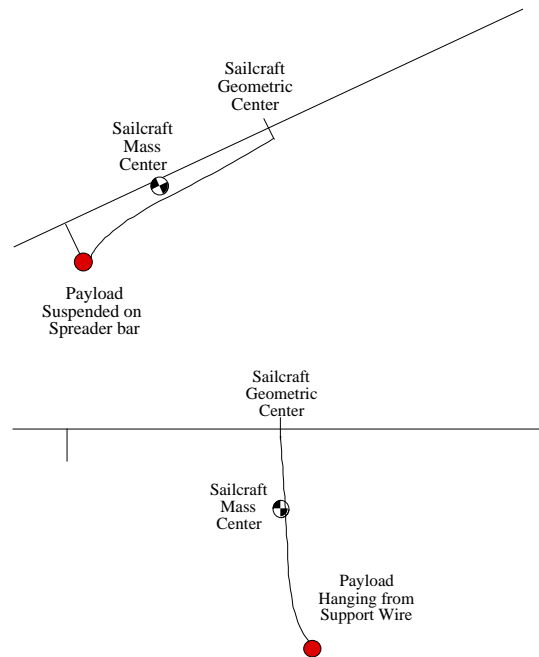

Figure 3-19 Sailcraft Pitch Control Technique

After the 300 day c.g. shifting maneuver, the solar sail will be passively stabilized with a zero degree pitch and roll angle. Once the sail is stabilized at zero degrees, the Yaw Control System will have a negligible effect on performance. At some point after 300 days, the solar sail will be far enough from the Sun that the power available from the solar arrays will not be sufficient to operate the yaw fin actuators. When this happens, the solar sail will slowly spin up about the yaw axis as

damping mechanisms transfer angular momentum to the highest inertia axis. This spin will increase the sail stability about the desired velocity direction.

4.0 PROGRAM SCHEDULE TO FLIGHT

The Team Encounter Preliminary Design phase was initiated in May 2001 - a nine month effort, with PDR in February 2002. During this phase, we anticipate the AeroAstro Bitsy kernel will fly, the boom ground tests will be completed, and the sail tests and seaming demonstrations accomplished. Also, ground control operations will be identified, negotiations with the launch provider complete, and the necessary governmental licenses applied for.

The preliminary design phase is followed by the two-year detailed development phase, with CDR anticipated in February of 2002, environmental testing in September/October of 2002 and launch in the last quarter of 2003 or the first quarter of 2004.

5.0 CONCLUSIONS

Team Encounter, AeroAstro, and L'Garde have begun the development of mankind's first purpose-built interstellar spacecraft. The feasibility of the design, particularly the solar sail, was verified in a conceptual design review and confirmed by a thorough third party review. The preliminary design phase is under way and is coincident with activities - flight and ground testing - to reduce program risk. The team expects development to conclude with the launch of the spacecraft on an Ariane 5 in 4th quarter 2003 or 1st quarter 2004.

The development risks for this mission are clear, but the potential benefits are enormous. When successfully flown, this revolutionary mission will demonstrate a major advance in space propulsion, establish the financial viability of entertainment-oriented space missions, and give 3-5 million people a chance to participate in a space mission. The Encounter Development Team warmly invites all humanity to participate in the mission and follow our progress at www.encounter2001.com.