

SSC01-I-7

Design of a High Performance Earth Imaging Microsatellite

Hong-Joon Chun, Byungjin Kim and Sungdong Park
SaTReC Initiative, Co. Ltd.

18F Sahak Bldg., 929 Dunsan-Dong, Seo-Gu, Taejon, 302-120 Korea
(Tel) +82-42-365-7512, (Fax) +82-42-365-7549, (Email) hjc@satreci.com

Abstract. Multispectral Earth Imaging Satellite (MEISAT) is SaTReCi's 100 kg micro satellite which will be adequate to support a high resolution multispectral Earth imaging camera. MEISAT, whose development is currently in progress, is capable of achieving a ground resolution of 8.5 meters with a 47 km swath width and 400 km scan length from its intended orbit of 730 km. The low-cost satellite is also capable of storing 8 Gbits of image data which will be transmitted to ground at 10 Mbps with an X-band transmitter. This paper provides an overview of MEISAT mission operation concept. The mission requirements and the system specifications are also discussed. The paper then describes the overall system configuration. The design of the command and data handling system, the power system, the attitude control system, the RF system, and the payload system is presented.

Introduction

While big remote sensing satellites dominate the commercial market for high resolution images, small satellites are continuously being evaluated for its suitability to perform the same task of providing high resolution images. Since the successful launch of EROS A2 that weighs 280 kg, such attempts utilizing small satellites have been proved to be valuable. Recognizing the cost effectiveness of small satellites, many future remote sensing programs are based on small satellites.

In attempt to develop satellites with a higher performance-to-cost ratio, SaTReCi, a commercial venture company established by engineers with more than ten years of experience of developing microsatellites, is currently developing two different types of next generation remote sensing satellites: one is a 100 kg microsatellite with 8.5 m ground resolution and the other is 200 kg small satellite with 2.5 m ground resolution. This paper focuses on the 100 kg one, called Multi-spectral Earth Imaging Satellite (MEISAT).

MEISAT carries a high-resolution multi-spectral camera system that provides 8.5 m ground sampling distance (GSD) at the nominal altitude of 730 km. The MEISAT system is advantageous in its cost effectiveness and smaller size compared to full-sized conventional commercial Earth observation satellites. The satellite weighs about 100 kg and is capable of generating a ground image strip of 47 km wide and 400 km long at a single satellite pass. It also has the maximum tilting capability of 45 degrees, corresponding to 780 km field of regard. The body-tilting capability makes the mission very flexible: MEISAT is capable of taking images of a specific target on the Earth surface with 15 m GSD or better at least every two days.

The considered mission covers a specific region with a short revisit time to allow frequent monitoring. For simple operation and mission scheduling, a sun-synchronous circular orbit has been selected. The attitude control system provides 0.5° (2σ) pointing accuracy through full 3-axis control using space proven sensors and actuators.

This paper describes the overall mission and the subsystems, presents key features of electro-optical payload, and discusses our future mission.

Mission Overview

SaTReCi has derived system requirements and baseline mission concept as to meet the mission objectives at minimum cost (see Figure 1).

The key objectives of MEISAT mission, summarized in Table 1, are to provide high quality Earth images with short revisit time.

The baseline design features an agile satellite that can be steered to accurately point the multi-spectral pushbroom type camera that excludes the need for gimbals or strip scan mechanism.

For an effective mission operation, the baseline MEISAT orbit has been assumed to be sun-

synchronous with an altitude of 730 km, which provides 2-day repeating ground track. The satellite is being designed to be compatible with various launch vehicles such as PSLV, ARIANE V, EUROKOT and COSMOS.

The satellite has direct links to the ground station using RF links after separation from the launch vehicle. S-band band is used for satellite control and housekeeping whereas X-band is dedicated for the image data downlink. Ground station whose cost is kept low using commercial-off-the-shelf (COTS) products, features high performance data receiving and processing systems developed by SaTReCi, and is capable of producing stereoscopic images.

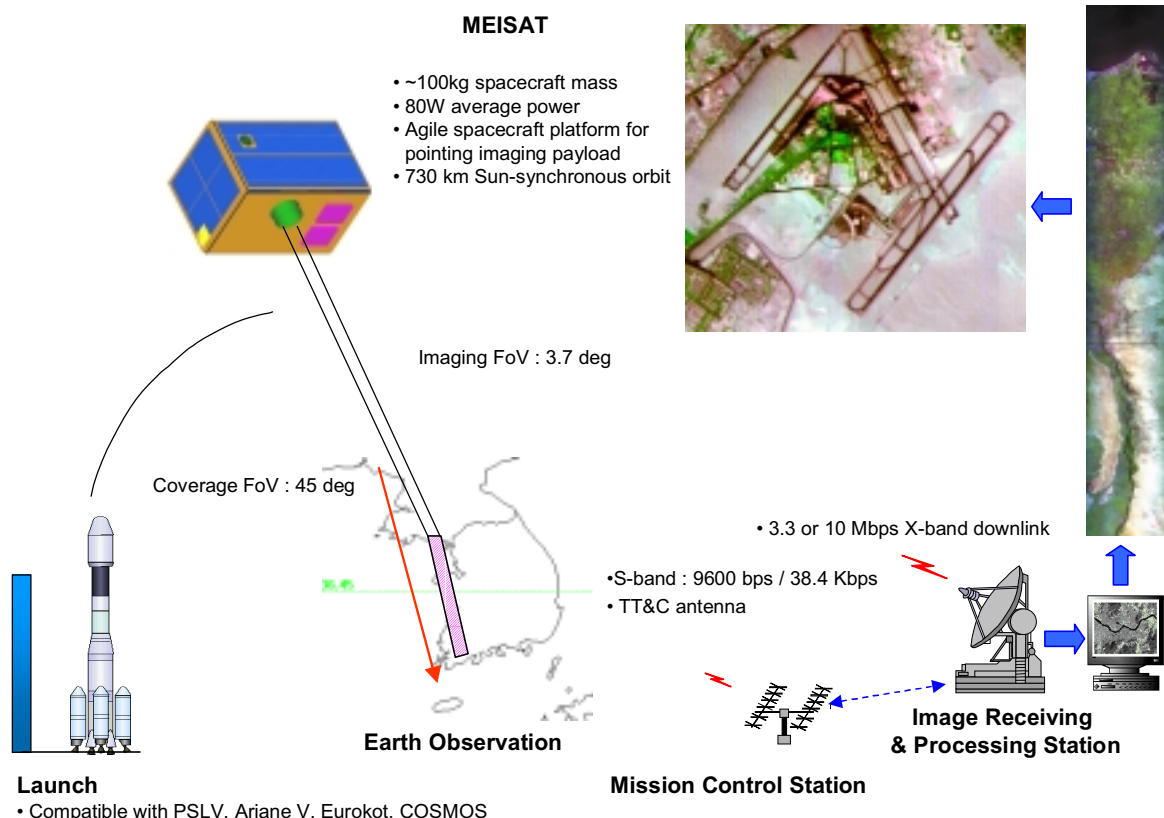

Figure 1. System Concept Summary

Table 1. Mission Summary

<i>Items</i>	<i>Description</i>
Low earth orbit micro satellite for remote sensing	Stable and agile satellite carrying a high-resolution multispectral camera on a 730 km sun-synchronous orbit
Regular and frequent imaging capability	Nadir images (8.5 m GSD) in every 33 days Lower resolution images (14.1 m) in every 2 days with 36 degrees of tilting
Various applications for remote sensing	Provision of stereoscopic and value added image products Advanced image receiving and processing system

Mission Requirements and Performance Summary

Key mission requirements and corresponding system specifications are shown in Table 2. Producing images of 8.5 m spatial resolution in 3 spectral bands allows generation of 1:100,000 scale map.

Table 2. Mission Requirements and Specifications

<i>Key mission requirements</i>	<i>System specifications</i>
Multispectral high resolution camera cartography	
Three multispectral bands with 10 m ground resolution 47 km swath width	Three bands with 8.5 m resolution as baseline 3.7° field of view (47 km swath width) 15 m localization / 20 m altitude mapping accuracy (90 %) using a precision star sensor and ground control points
1:100,000 scale mapping capability	
Short revisits	2 days: @730 km altitude and with 36° off nadir pointing
Duty cycle and lifetime	
10 % of imaging payload duty cycle Reliability of 0.8 at the end of 3 years of guaranteed life	Battery capacity: 10 Ah Implementation of redundancy, parts selection, battery management, and safe modes

To meet the revisit and coverage requirements, the satellite is capable of tilting maximum of $\pm 45^\circ$ off the nadir ground track, yet maintaining the ground station contact (see Figure 2).

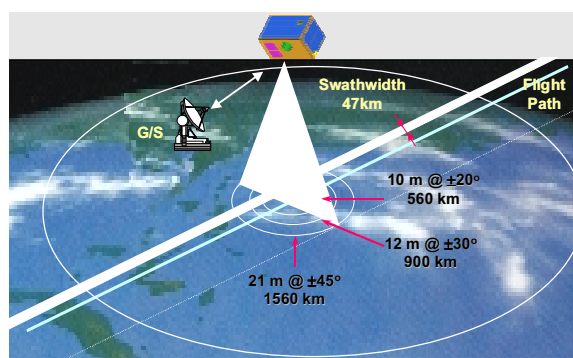

Figure 2. Imaging Flexibility

MEISAT is capable of achieving a ground resolution of 8.5 m with a 47 km swath width and 400 km scan length. When the satellite is tilted at 45° , the resolution goes down to 21 m.

Accurate attitude knowledge is obtained using gyros and a star sensor. The attitude control system provides sufficient stability during imaging, and satisfies the mapping accuracy requirements with minimum ground control points. Pointing of the satellite is performed using four reaction wheels which allow fast attitude slewing and stabilizing.

Image data are transmitted to the ground at 10 Mbps using an X-band link. This enables downloading 8 Gbits of stored image data within two passes.

Bus System

MEISAT is designed to satisfy all mission requirements by incorporating three-axis stabilized, accurate, and agile attitude control for precise imaging operations.

MEISAT is of a modular design to encompass not only the current mission but also future missions of diverse applications (see Figure 3). The modular design of the satellite allows the reconfiguration of payload modules with the minimum impact on the satellite. The satellite, whose dimension is $500 \times 500 \times 740 \text{ mm}^3$, weighs about 100 kg and has a stack-type rectangular structure as depicted in Figure 3.

Passive thermal control schemes will be applied to maintain the temperature of components and subsystems within the specified temperature ranges. In order to meet the thermal requirements, various thermal coating materials and thermal conductors are used, and component locations and mounting configurations are carefully taken into considerations.

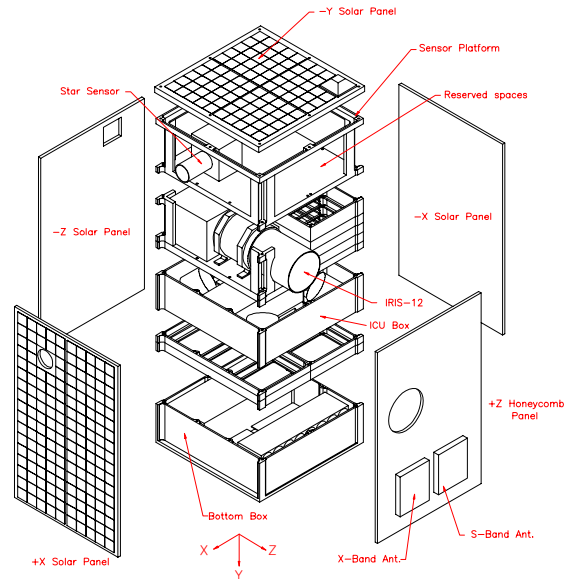

Figure 3. Exploded View of MEISAT

System Overview

Figure 4 shows the satellite system architecture at a subsystem level. This simple satellite architecture is suitable for small satellites in which a number of subsystems is small and a high communication rate is required.

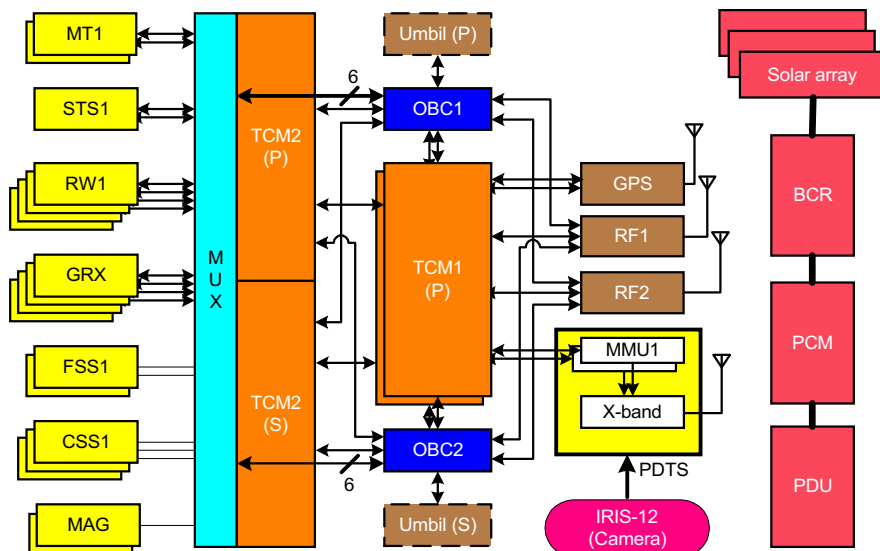

Figure 4. Satellite System Architecture

Command and Data Handling Subsystem

The Command and Data Handling (C&DH) subsystem handles serial communications for the satellite bus and the payload. Included in these communications are telemetry data that indicate the health and status of all equipment on-board the satellite and a command link for real time control of satellite elements. In addition to the real time commanding of the satellite, an on-board computer provides the ability to store time-tagged commands that are executed when the satellite is out of contact with the ground station.

As shown in Figure 4, C&DH subsystem is comprised of one primary On-Board Computer (OBC1), one secondary On-Board Computer (OBC2), four Telemetry and Command Modules (TCMs) – TCM1 (primary & secondary) and TCM2 (primary & secondary).

The primary OBC (OBC1) performs all housekeeping functions & subsystem operations, and controls communications with the ground station. The secondary computer (OBC2) runs attitude control software tasks. When either one of OBCs are down, the other takes over the tasks of the failed one.



Figure 5. Picture of Prototype Model OBC

OBC is based on the TS68EN360 CISC processor, running at 25 MHz. TS68EN360 has enhanced computing and communication capability, and enables the handling of more complex software tasks (see Figure 5). OBC incorporates 12 serial communication channels with TCMs and RF subsystem (see Figure 4). Each OBC has 2 Mbytes

of Error Detection and Correction (EDAC)-protected memory for flight codes and 6 Mbytes of software-EDAC-protected memory for telemetry data.

The Telemetry and Command Modules (TCMs) handle commands and telemetry data by communicating with subsystems. TCMs also control power switches for subsystems. Primary and secondary TCM1s are both turned on to control the communication link of the satellite. As depicted in Figure 4, the data from attitude control sensors and actuators are fed to TCM2, which are then passed either to OBC1 or to OBC2. TCM2s are exclusively used for attitude control sensors and those data are sampled at a high rate (~ 2Hz) with the minimum communication delay. TCMs can provide direct serial communication links to subsystems at a rate of 38.4 kbps.

Electrical Power Subsystem

The Electrical Power Subsystem (EPS) is designed to provide robust and sufficient power to ensure reliable operations of the satellite throughout the mission – it provides more than 80 Watts at End Of Life (EOL). EPS generates, stores, regulates and distributes electrical power to all subsystems including the payload. EPS consists of solar panels, batteries, Battery Charge Regulator (BCR), Power Conditioning Module (PCM), Power Distribution Unit (PDU), and Battery Monitor (BM) (see Figure 4).

Flight-qualified GaAs solar cells are chosen to generate power for the satellite. The battery pack consists of 22 serially connected NiCd cells, each with capacity of 10 Ah. In eclipse, the maximum depth of discharge is kept below 20%. BCR regulates the power generated from solar cells and provides the regulated power to the satellite during daytime. PCM regulates 28V unregulated bus power and generates +5V / ± 12 V regulated power from BCR and batteries. BM monitors the status of batteries and solar cells. BM provides the single point ground plane for the whole satellite system. It also monitors the charge-discharge current, voltage and temperature of the battery pack and of each solar panel.

Attitude Control Subsystem

The Attitude Control Subsystem (ACS) stabilizes the attitude of the satellite using reliable space proven sensors and actuators. ACS achieves autonomous three-axis stabilization in a closed-loop manner using an on-board computer. ACS consists of two magnetorquers (MTs), two fine sun sensors (FSSs), three coarse sun sensors (CSSs), one star sensor (STS), two magnetometers (MAGs), and four sets of reaction wheels and fiber optic gyros (see Figure 4).

ACS allows the attitude pointing accuracy and control stability of better than 0.5° (2σ) for all three axes and $0.016^\circ/\text{sec}$ for quality imaging, respectively. STS provides the attitude knowledge better than 1 arc min (2σ). The sensor data are sampled at 2 Hz.

RF Subsystem

The RF subsystem supports 9600 bps / 38.4 kbps S-band uplink and downlink for satellite control and monitoring.

Electro-Optical Payload

Figure 6 depicts the system block diagram of the primary payload, IRIS-12. It consists of Electro-Optical Subsystem (EOS) and Payload Data Transmission Subsystem (PDTs). EOS consists of the telescope with various optical and mechanical components, the Focal Plane Assembly (FPA), and the Signal Processing Unit (SPU). FPA houses space-qualified linear CCD detectors and the front-end electronics. PDTs consists of the Mass Memory Unit (MMU) and the Image Transmission Unit (ITU).

A pushbroom mechanism is employed for imaging. The IRIS-12 provides 8.5 m spatial resolution at nadir. The baseline multi-spectral capability includes 2 visible bands (red and green) and 1 near infrared (NIR) band.

The SDRAM-based Mass Memory Unit provides more than 8 Gbits of storage capacity, with which

IRIS-12 is capable of taking images of a ground strip longer than 400 km in a single satellite pass.

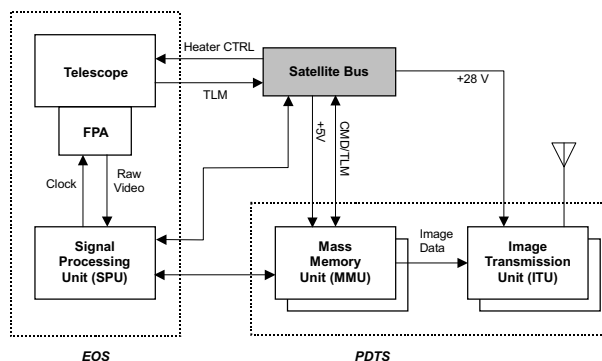

Figure 6. System Block Diagram of IRIS-12

Table 3. Key Features of IRIS-12

Items	Key Features
Multi-spectral Imaging	520 ~ 600 nm, 630 ~ 690 nm, 760 ~ 890 nm
High spatial resolution	8.5 m Ground Sample Distance (GSD) @730 km nadir, 120 mm aperture diameter, MTF > 15 % @ Nyquist Freq.
Large swath width	Minimum swath width of 47 km @ 730 km
High radiometric performance	High-speed, low-noise CCD detectors, Overall system SNR > 70, High image contrast
Rugged opto-mechanical subsystem	On-axis telescope, Insusceptible to harsh temperature variations
High-performance signal processing	High-speed and superior performance signal processing, Programmable gain control / automatic offset correction
Large storage capacity	8 Gbits of SDRAM modules, Capable of storing more than 47 km x 400 km image data
High-speed X-band image transmission	3.3 or 10 Mbps data rate, with QPSK modulation, Provides a real-time, sub-sampled image transmission, Fast delivery of requested image data

IRIS-12 includes an X-band Image Transmission Unit that can transmit stored image data of maximum of 8 Gbits within two satellite passes at 10 Mbps. The high-speed transmission capability enables the prompt use of images. In addition, IRIS-12 has a function of transmitting the sub-sampled image data in real-time that is useful for pre-assessment of image quality.

The features of IRIS-12 are summarized in Table 3. The baseline design meets all imaging mission requirements.

Future Mission

Most of the current MEISAT design has well been applied to SaTReCi’s 200 kg remote sensing satellite, called Medium Aperture Camera Satellite (MACSAT) (see Figure 7).

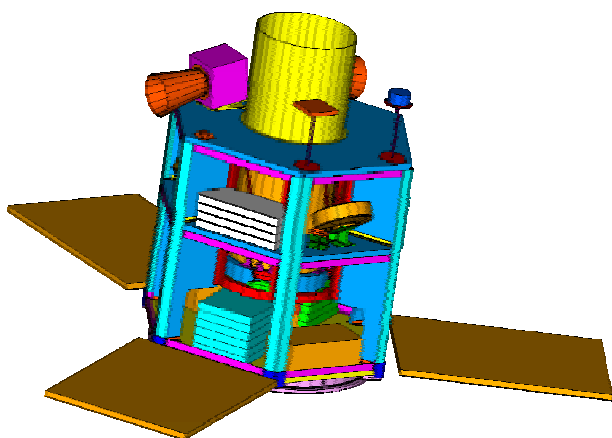

Figure 7. Exploded View of MACSAT

Hexagonal-shaped MACSAT’s three deployed solar panels produce more than 270 W of power at EOL. Its attitude control system provides 0.1° of control accuracy, which is enough for taking images of 2.5 m resolution. Image data are stored in 32 Gbits of SDRAM memory, and are transmitted to ground at 30 Mbps. The overall system specifications are summarized in Table 4.

Summary

We have described the design of our 100 kg micro satellite, MEISAT, whose prototype model development of each subsystem has just been completed. Although basic functions of the subsystems have been tested and verified, full integration tests have not yet been taken place.

Table 4. Overall System Specifications

<i>Items</i>	<i>Specifications</i>
Mass	< 200 kg
Dimension	φ 1.2 × 1.2 m
Power	270 W @ EOL (GaAs solar cells)
GSD / Swath width	2.5 m (Pan), 5 m (MS) / 20 km (@685 km nadir)
Spectral Bands (MS)	4 (red, green, blue & NIR)
Memory Size	32 Gbits (SDRAM)
Attitude Accuracy	0.1° (3-axis stabilized)
Attitude Knowledge	10 arc sec
TT & C	S-band (9.6 / 38.4 kbps)
Image Transmission	X-band (30 Mbps)
Mission Life	> 3 years

The enhanced micro satellite will be launched into a 730 km sun synchronous orbit, and will produce high quality multi-spectral Earth images with 8.5 m resolution.

The specifications of SaTReCi’s 200 kg satellite system have also been briefly described, which will produce both panchromatic and multi-spectral images at 2.5 m and 5 m resolutions, respectively.

The design of both satellites is based on the past 10 years of experience of designing, developing, launching and operating three micro satellites successfully – one of them being a 100 kg three axis stabilized satellite with 15 m resolution.

We believe that our space technology and experience from these two missions will allow us to take part of developing more sophisticated satellite systems, and also wish to collaborate with organizations worldwide.

References

1. Lee, H., B. J. Kim and S. Park, "MEISAT (Multi-spectral Earth Imaging Satellite) Mission Analysis" Proceedings of 3rd IAA Symposium on Small Satellites for Earth Observation, Berlin, April 2001.