

SSC01-I-4

A Novel Concept for Monitoring of Maritime Traffic by Micro-Satellites

B. T. Narheim, T. Eriksen, G. K. Høye, T. Wahl
 Norwegian Defence Research Establishment (FFI)
 POBox 25, N2027 Kjeller
 Norway

Bjorn-T.Narheim@ffi.no

Phone: +47 6380 7308

Torkild.Eriksen@ffi.no

Phone: +47 6380 7316

Gudrun-Kristine.Hoye@ffi.no

Phone: +47 6380 7322

Terje.Wahl@ffi.no

Phone: +47 6380 7469

Abstract. A concept for monitoring of maritime traffic by micro-satellites has been studied at FFI [1]. The concept is based on localization of maritime vessels by passive detection of their X-band navigation radar (3 cm wavelength), and subsequent direction finding and determination of the geographic position. A Phase-A study [3] on the utilization of this concept, for monitoring of the maritime traffic in ocean areas under Norwegian jurisdiction has demonstrated the feasibility of the concept. Localization of vessels can be performed to an accuracy of 1 km or better from a micro-satellite orbiting at 600 km altitude. The concept requires the position and attitude of the micro-satellite to be determined with a very high accuracy in all axes. A high performance micro-satellite is therefore required for this concept. Heavy real-time data processing on-board the satellite will transform the radar signals into position and possibly also heading information of the vessel hosting the radar. This information will be broadcasted to stationary and mobile users on ground on a low-rate downlink.

Introduction

Maritime issues play a vital role in most coastal countries. The associated ocean areas contain highly valuable resources, and are also an important highway for transportation of goods and people. Monitoring the maritime activities in these areas is of growing importance, but can be a challenging and resource demanding operation dependent on the size and geographic location of the ocean areas. For a small country like Norway, with major ocean areas in the arctic regions, the monitoring of maritime traffic is particularly demanding during the winter season, with short days and rough weather. Figure 1 shows a map of the ocean areas under Norwegian jurisdiction. The areas amount to 2.2 Mkm², and more than 50% is located north of the Arctic Circle.

Maritime surveillance has to date mainly been based on methods such as the Coast Guard, long range radars and surveillance aircraft. Only in recent years has the surveillance been supported by images from radar satellites (Figure 2). These satellites have proved very useful by providing a more instantaneous overview of

large ocean areas, also far from the mainland, but they are hampered by certain limitations:

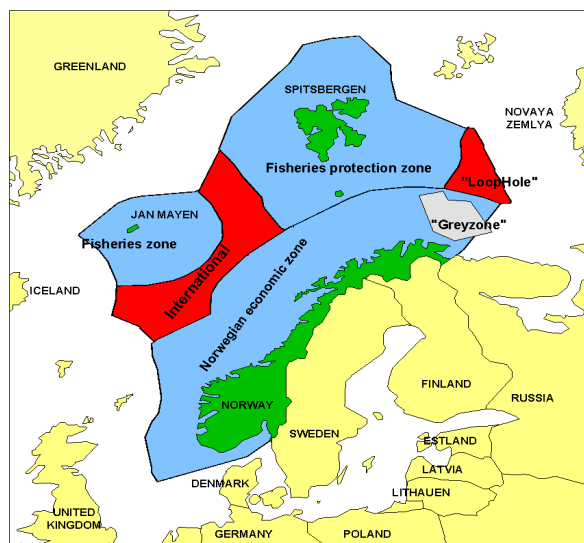

Figure 1. Map showing the Norwegian ocean areas (in blue) extending into the arctic region.

1. They only give information on presence and position of ships, not on type, identity or nationality.
2. The swath width is limited to some 300 km, which is insufficient for daily coverage.
3. The satellites are large and expensive, and are not under national control of the smaller nations.

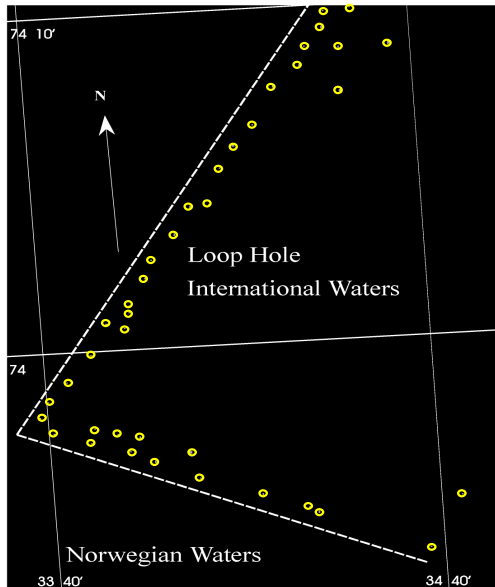

Figure 2. Picture from RADARSAT showing fishing vessels (marked by yellow circles) along the Norwegian boarder in the "Loop Hole".

A technique for improved surveillance of maritime activities, which addresses the above issues, is discussed in the following. The technique is based on a radar detector installed on-board micro-satellites, for passive detection and localization of a vessel's navigation radar, and thereby the vessel itself. This technique will allow ships to be located with an accuracy of 1 km or better, which is deemed acceptable for this type of ocean surveillance.

The Monitoring Concept

The International Convention for the Safety of Life at Sea (SOLAS) requires all vessels longer than 45 m to be equipped with a navigation radar operating in the X-band (9.3 - 9.5 GHz, 3 cm wavelength), but navigation radars are today also found on smaller vessels such as fishing boats. Navigation radars have a powerful transmitter with a pulsed output power of typically 1-50 kW. The antenna lobe is only a few degrees in azimuth and a few tens of degrees in elevation, and is pointed horizontally.

It can be shown [2] that when the main lobe of the navigation radar is pointed towards the main lobe of a detector antenna, a $50 \times 50 \text{ cm}^2$ detector antenna will be sufficient to detect the radar signal even at ranges beyond 3000 km. Placing the detector antenna 600 km above the Earth, and pointing it just below the Earth's horizon will allow such main lobe to main lobe detection, of navigation radars located close to the horizon to take place.

Partitioning this detector antenna into horizontal and vertical elements, and adding a set of receivers and phase meters will form an orthogonal radio interferometer that will find the position to vessels at sea. The area covered on ground will be approximately 1200 km in range and 150-300 km in azimuth [2].

The antenna size of $50 \times 50 \text{ cm}^2$ is within the range of typical micro-satellite dimensions, and the antenna can therefore easily be installed on-board a micro-satellite. Pointing the antenna transverse to the velocity direction of the satellite will give an observation swath on ground of 1200 km. This is four times better than for present radar satellites.

Figure 3 illustrates the radar detection geometry, while Figure 4 shows the coverage area obtained for a 10 min. observation period of Norwegian ocean areas during a favorable orbit.

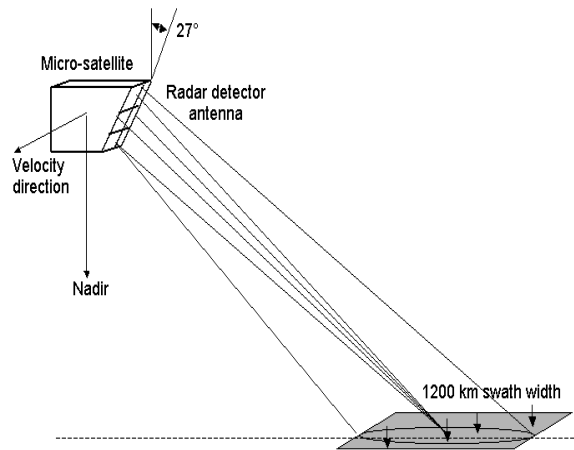

Figure 3. The radar detection geometry obtained with a $50 \times 50 \text{ cm}^2$ radar detector antenna located on-board a micro-satellite orbiting at 600 km altitude.

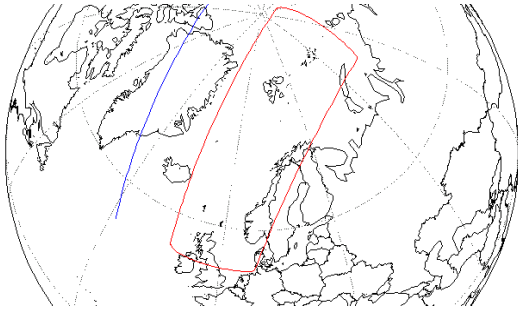

Figure 4. 10 min. coverage (red rectangle) obtained from a 600 km polar orbit when the radar detector antenna is pointed sideways. The blue line to the left of the rectangle marks the satellite's ground track.

The radio interferometer

Navigation radars are transmitting X-band pulses with a typical length of 100-1000 ns, at a repetition frequency of about 1 kHz. In order for a radio interferometer to localize and classify the radar emitters, the interferometer must be a high performance unit capable of handling several tasks:

1. Detect the radar pulses
2. Measure the pulse parameters
3. De-interleave the pulses
4. Measure the emitter parameters
5. Determine the emitter position
6. Classify the emitters

This is obtained by using the multi element detector antenna, receivers, D/A converters, and a powerful data processing unit [2].

Figure 5 shows a block diagram of a possible radio interferometer. The detector antenna is a patch antenna where each element is connected to a receiver with D/A converters through a feed network. High-rate front-end signal processing is performed in Gate Arrays (GA), while the more algorithmic processing is performed in a dedicated data processing unit (Proc).

The processing unit will transform the interferometer data to geographic coordinates. This will significantly reduce the amount of data, and will allow the generation of a small data product of vessel information that can be transmitted to ground. The data product will typically contain time, geographic position (longitude, latitude), position accuracy, heading, and the type and operating mode of the detected radar.

Assuming an average density of 5 detected vessels per second, the average data rate will be as low as a few

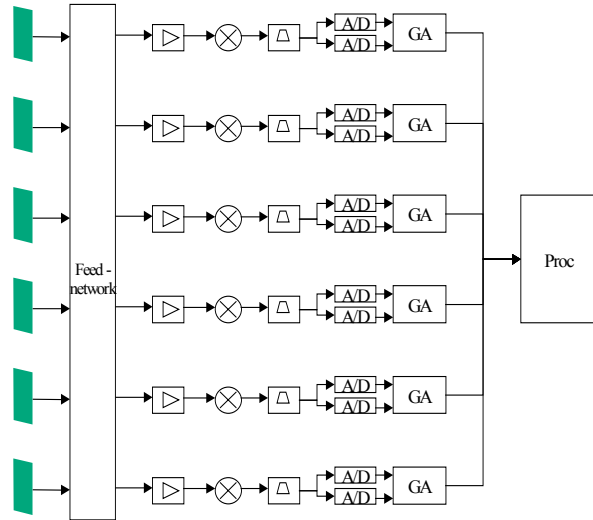

Figure 5. Block diagram of the radio interferometer.

hundred bits/s. The satellite will therefore be able to broadcast this data in real time, on a low-rate downlink directly to stationary or mobile users. A picture of the maritime traffic can then be assembled at a low-cost user terminal.

Error Sources

Several error sources will affect the ability of this concept to precisely determine the geographical position of vessels at sea. The dominating error sources are:

1. The ability of the interferometer to detect the radar pulses and to determine the angle of arrival.
2. Atmospheric refraction of radio waves for radar emitters located near to the Earth's horizon.
3. The ability to precisely determine the satellite attitude.
4. The ability to precisely determine the satellite position.
5. The thermal characteristics (mechanical stability) of the detector antenna.

In order to obtain the vessel localization accuracy of 1 km or better, and to maintain an effective swath width of 1200 km the spacecraft attitude and position must be determined very precisely, and the attitude control must be accurate and fast. The satellite attitude should be determined to within 0.001° , and should be controlled to within 0.5° in all axes. The satellite position should be determined by GPS.

Since the radar detector is a radio interferometer measuring phase differences between the antenna elements, the mechanical and thermal stability of the detector antenna panel is of vital importance. Thermal stresses in the spacecraft structure should not be coupled to the antenna panel, and the antenna panel itself must have an ultra stable design resulting in an overall stability in the micron range.

These satellite requirements are quite severe, and are usually not associated with micro-satellites.

The NSAT-1 Mission

FFI has recently performed a Phase-A study [3] on “A Norwegian Micro-satellite for Ocean Surveillance” (NSAT-1), which is thought to be the first Norwegian observation satellite. The purpose of the NSAT-1 demonstration mission is to evaluate the prospects for the maritime monitoring concept described above to become an efficient and affordable tool for surveillance of ocean areas under Norwegian jurisdiction. The Phase-A study was basically performed to:

1. Develop a concept for a satellite based ocean surveillance system under national control.
2. Establish an overall system architecture and associated system requirements.
3. Evaluate a few micro-satellite design options compatible with secondary or shared launch alternatives.
4. Provide a ROM cost estimate for the realization of the NSAT-1 demonstration mission.

An overview of the NSAT-1 mission concept resulting from this study is shown in Figure 6. The main elements are:

1. The NSAT-1 satellite carrying the radar detector
2. A ground station
3. A satellite control center
4. A performance evaluation center
5. Three user terminals on land
6. One user terminal on a mobile unit (ship)
7. A user center
8. Radio beacon(s)

In order for the NSAT-1 mission to become a viable alternative to existing radar satellites, the overall performance, for monitoring of naval traffic should exceed the capability of the radar satellites. The NSAT-1 demonstration mission requirements are as follows:

1. Obtain full coverage of Norwegian ocean areas at least four times per day.
2. Detect 99% of all active navigation radars.
3. Determine vessel position to within 1 km.
4. Classify the radars by type and mode.
5. Obtain heading information.
6. Provide vessel information to users on ground in real time.
7. Operate the satellite from Norwegian soil.

The geographic location of the Norwegian ocean areas favors a polar orbit for frequent area coverage. The NSAT-1 should therefore be launched into a 600-800 km circular polar orbit. In contrast to radar satellites NSAT-1 can be turned to always point the detector antenna towards Norwegian ocean areas. This will increase the number of orbits with good coverage, but will reduce the swath width to 300 km when the antenna is pointed along the trajectory.

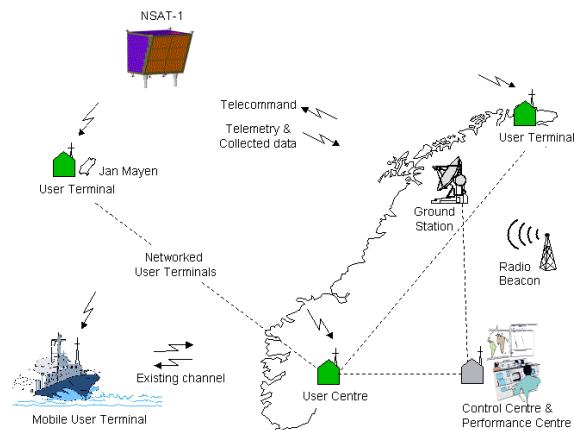

Figure 6. The NSAT-1 concept for monitoring of ocean areas under Norwegian jurisdiction.

The Satellite Design

The satellite shown in Figures 7 and 8 is the result of a design effort made by FFI [4]. The main goals for the design were to:

1. Provide a proper environment for the payload and the spacecraft subsystems.
2. Select and accommodate a suite of modern spacecraft subsystems capable of delivering the required performance.
3. Support a 10 min. operation of the radar detector every orbit.
4. Provide good communications during observation periods.

5. Develop a simple and robust mechanical structure that would accommodate the solar arrays without the need for deployable panels.
6. Arrive at a low cost satellite design suitable for a secondary launch option.

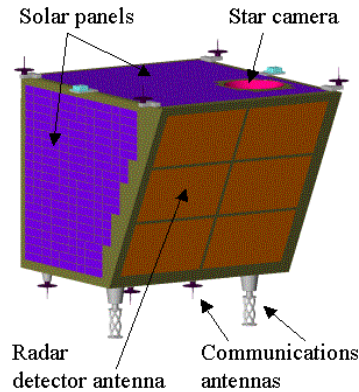

Figure 7. External view of the NSAT-1 satellite designed by FFI.

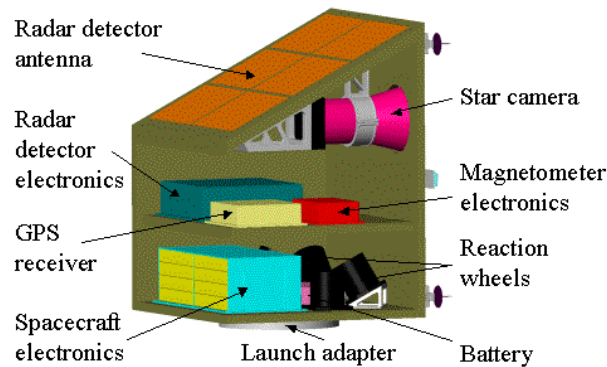

Figure 8. Internal view of the NSAT-1 satellite designed by FFI.

An ASAP5 launch was selected for the design exercise. This restricted the length of the satellite to 71 cm. The cross section is 50x55 cm², which is defined by the 50x50 cm² radar detector antenna that is tilted. The launch weight will be about 50 kg. Power was early found to be a critical resource, and a 600 km polar dusk/dawn orbit was therefore selected for this design in order to obtain the highest possible orbit average power generation. This orbit also seems as a favorable orbit for obtaining good thermal stability.

The attitude and position determination errors are critical factors for meeting the required vessel localization accuracy. A high precision star camera and a GPS receiver will clearly be needed. The attitude determination and control system designed to meet the

above requirements, at an affordable cost, contains the following elements:

1. A star camera pointed along the zenith axis during observations, to avoid seeing the sun. The attitude determination accuracy is approximately 0.002°. This value is acceptable provided a close and stable coupling between the camera and the detector antenna can be obtained and maintained.
2. A precise GPS receiver.
3. Reaction wheels providing the required 0.5° attitude control in all axes
4. A three-axis magnetometer.
5. Three magnetic torque coils for reaction wheel momentum dumping.
6. Sun sensors for coarse and fast attitude determination.

The communications system has two equal pairs of receivers and transmitters. The uplink should have a bit rate of 5-10 kbit/s. The downlink should be a dual bit rate link with a 1-2 Mbit/s high-rate mode, and a 5-10 kbit/s low-rate mode. The communications links will be used as follows:

1. The low-rate command uplink is used for satellite control and software upgrades.
2. One low-rate downlink is used for health and status information from the spacecraft and the payload.
3. The high-rate downlink is used for raw data from the payload. This data is required in the early phase of the mission for evaluation of the interferometer performance.
4. The second low-rate downlink is used for real time broadcast of vessel information.

The power subsystem must deliver 38 W of orbit average power to the other satellite subsystems and the payload, plus ample margins for conversion losses and lifetime degradation. The power subsystem contains the following elements:

1. Triple-junction GaAs solar arrays on two adjacent spacecraft surfaces with a total of 31 strings of 18 solar cells each. During non-observation periods the solar panels are oriented towards the sun (45° incidence angle on each panel) to generate a peak power of 107 W. During the shortest power generation period (winter solstice) the power available to the spacecraft and payload will be 58 W, leaving a margin of 20 W (~50%) at the beginning of life.
2. A maximum power point tracker to optimize the power generation.

3. A 4.5 Ah Li-Ion battery providing power during the 10 min. operation periods of the radar detector and during eclipses.
4. Transistor switches and latching current limiters to control the power distribution.

The mechanical structure is a self-supported design made of aluminum honeycomb panels. This will give a good structural stiffness and good thermal conductivity. The radar detector antenna will be an integral part of this structure as shown in Figures 7 and 8. The star camera will be mounted directly onto the antenna panel to minimize the alignment errors between the antenna and the star camera.

The User Terminal

The user terminal is a central element in the ground infrastructure for the NSAT-1, as shown in Figure 6. It will be a compact, low cost terminal with an omnidirectional antenna receiving the vessel information broadcasted from the satellite on the low-rate downlink. The terminal is designed to assemble a traffic picture from the broadcasted vessel information in real time, and can be installed at stationary locations or on mobile units such as the Cost Guard.

Since the radar detector on-board the satellite is pointed just below the horizon during observations, the satellite may be out of range from the mainland while still collecting valuable information from Norwegian ocean areas. Three user terminals located as shown in Figure 6, and connected to a network are therefore required for full access to the broadcast link during all valuable passes. The user center in Figure 6 is the hub of this network and will, during routine operations be able to monitor the activities in the Norwegian ocean areas several times a day.

Radio Beacons

One or more radio beacons, as shown in Figure 6 will be required for in-flight determination of the alignment between the star camera and the radar detector antenna, and to routinely check this alignment. Existing stationary X-band radars would serve this purpose.

If a user terminal is located next to an X-band radar and a GPS receiver (e.g. on-board a vessel), a relative correction of the position of all other vessels in the traffic picture could be performed. This would clearly improve the quality of the traffic picture.

In a more Global Perspective

The 1200 km wide swath means that one polar orbiting satellite can provide one daily coverage or better of all areas between the poles and the 26° parallel. This area coverage is reduced to about 90% at the equator. One equatorial satellite would, however, give 15 observations per day of tropical or sub tropical areas. A constellation of satellites at various inclinations could therefore provide a more global monitoring of the maritime traffic. Figures 9, 10 and 11 show examples of areas that could be covered from an equatorial and a 30° inclined orbit.



Figure 9. A 10 min. observation period would cover the entire Mediterranean (red rectangle) when looking sideways from a 30° inclined orbit.

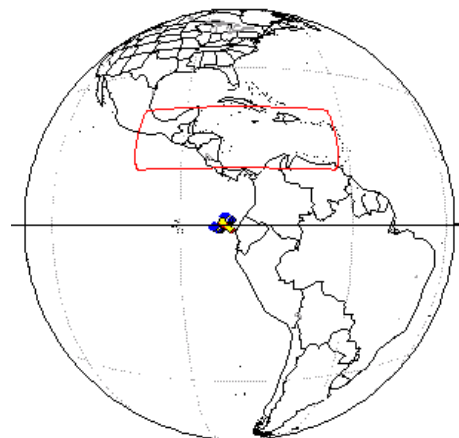

Figure 10. A 10 min. observation period would cover the Latin American ocean areas (red rectangle) 15 times per day when looking sideways from an equatorial orbit.

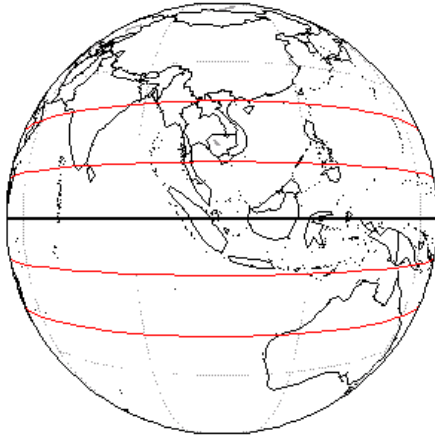

Figure 11. The ocean areas between the red lines could be covered 15 times per day from a sideways looking detector in an equatorial orbit. Pointing the detector more along the velocity direction would narrow the coverage areas and move them closer to the Equator.

Conclusions

Passive detection of navigation radars, by a high performance radar detector on-board a micro-satellite in a 600 km circular orbit will be able to determine the geographic position of maritime vessels to the same accuracy as today's radar satellites, but with some added features:

1. More information about the ship's identity.
2. A much wider swath (1200 km) resulting in more frequent coverage.
3. The cost would be within reach for the smaller countries.
4. The satellite can be under national control of the smaller countries.

References

1. Narheim B, Wahl T, Høye G, Eriksen T (2000), "A New Micro-Satellite Based Technique for Surveillance of Maritime Traffic in Norwegian Waters", FFI/NOTAT-2000/01119
2. Våland P A, Hjelmstad J, Danielson P, Høye G K (2000), "NSAT Microwave Payload Phase-A report", Ericsson Radar AS, Skjetten, Norway.
3. Narheim B T, Eriksen T, Høye G K, Wahl T (2001), "A Norwegian Micro-Satellite for Ocean Surveillance, NSAT-1 Phase-A Report"; FFI/RAPPORT -2001/03049 (In Confidence)
4. Sagsveen B S (2001), "Mechanical and thermal design considerations of the NSAT-1 micro-satellite", FFI/RAPPORT -2001/02933