

Modular and Reusable Miniature Subsystems for Small Satellites: An Example Describing Surrey's Nanosatellite S-Band Downlink

ZA Wahl, KL Walker, Dr. J Ward
Surrey Satellite Technology Limited
University of Surrey
Guildford, Surrey GU2-7XH, UK
Tel: (+44) 1483 259278 Fax: (+44) 1483 259503
e-mail: z.wahl@eim.surrey.ac.uk

ABSTRACT. For more than a decade, engineers at Surrey and elsewhere have been advocating a modular approach to satellite engineering, and demonstrating this approach with practical missions. The electro-mechanical modularity pioneered by Surrey and AMSAT on their microsatellites has been emulated by many groups building satellites in the faster, better, cheaper paradigm. Paradoxically, the technique is now being applied to both larger satellites (minisatellites) and smaller satellites (nanosatellites). Simultaneously, the underlying technology is advancing and functional density is increasing rapidly. The standard 330 x 330 x 30 mm module characteristic of Surrey's early satellites is inappropriate both for nanosatellites and for the increasingly dense electronics now available.

As part of the Surrey Nanosatellite Applications Program (SNAP), we have investigated a smaller, more modern modular unit based on the "Eurocard" standard. This paper describes the new modular approach, and some of the subsystem functions which can now be embedded in the 120 x 160 x 20 mm unit.

Using modules based on the in-house SNAP standard, Surrey can now design minisatellites, microsatellites and nanosatellites sharing common subsystem designs where appropriate. This updated modular approach still confers benefits in flight heritage, technology insertion, redundancy, system design and analysis and manufacturing.

BACKGROUND

Since the launch of UoSAT-3 in 1991 (a "microsat"), Surrey Satellite Technology Limited (SSTL) has been using 330 x 330 x 30 mm module boxes for all its Microsat customers. These modules are easy to stack together, enabling quick and easy Assembly, Integration and Test (AIT) of the satellite. SSTL still uses this approach and has over 30 orbit years of heritage. The advantages being modularity, speed of AIT, and robustness to vibration. This approach has been emulated by most other competitors in the small satellite market.

However, this product's performance density is limited by the module box size. State-of-the-art, down sized surface mount electronics make it possible to implement core systems much smaller than the original microsat module box, thereby increasing the performance density of the bus system core modules. This in turn means that it is possible to fly a more powerful and heavier payload than would otherwise have been possible for a given satellite mass and volume. The first instance of the use of

such enabling technology would be the SNAP-1 Nanosatellite.

The SNAP-1 Nanosatellite

The Surrey Nanosatellite Applications Platform satellite was funded by SSTL research and development, with the goal of producing a practical, modular, low-cost, multi-mission platform with a very high performance density in a very small volume^{1,2}.

In October 1999, it was organised that SNAP-1 could be launched as a secondary payload alongside a satellite called Tsinghua-1, a mission involving the collaboration of SSTL and Tsinghua University (China).^{3,4} As a result of the launch agreement, the mass of the Nanosatellite had to be 8kg or less. This set a very demanding technical requirement for SNAP-1. SSTL defines a Nanosatellite as having a mass of 10kg or less.

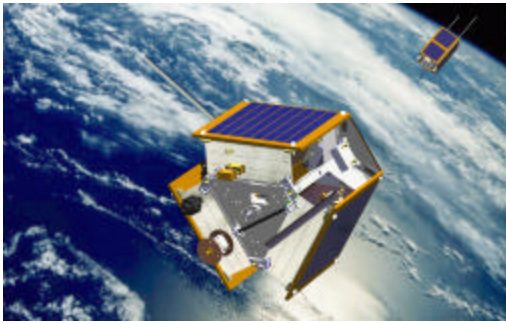

Figure 1. SNAP-1 and Tsinghua-1 in LEO

SNAP-1 Mission Objectives

The goals of the SNAP-1 nanosatellite are outlined briefly as follows:

PRIMARY GOALS	
1	To validate SSTL's new nanosatellite platform.
2	To take pictures of another satellite in orbit and convey them back to the earth.
SECONDARY GOALS	
3	To take pictures of the Earth.
4	To demonstrate an inter-satellite link.
5	To demonstrate differential GPS.
6	To demonstrate formation flying.
7	To demonstrate use of CCSDS telemetry.

The SNAP-1 nanosatellite does not have any redundant subsystems. This is done deliberately to achieve the highest possible performance density from the mission. More detailed information on the mission is available.

The SNAP-1 nanosatellite was completed on time and was due for launch in late June 2000.

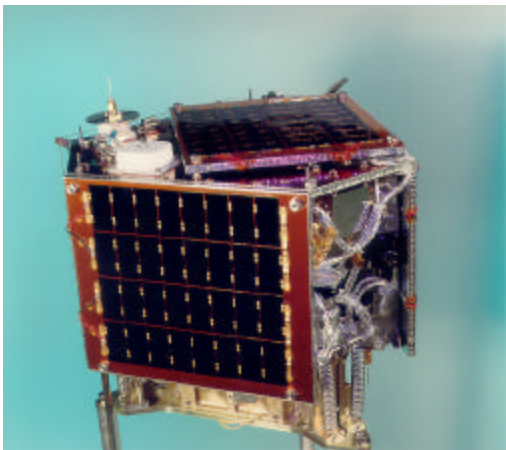

Figure 2. SNAP-1 :Ready to go!

S-Band Down-link Transmitter

The SNAP-1 S-Band Downlink transmitter will be used as an example to show some of the enabling technologies that are available to make such a mission possible and at relatively low cost.

A picture of the S-Band Downlink transmitter module is shown in Figure 3 below.



Figure 3. S-Band Down-link Module

The technical specifications of the SNAP-1 S-Band transmitter are given below in Table 1:

TABLE 1. S-Band Transmitter Specifications

Data Rate	38.4/76.8 kbps selectable, (capable of up to 20Mbps)
Modulation	BPSK/QPSK selectable (capable of any modulation)
TT&C	Controller Area Network (CAN)
Coding	Convolutional, $r=1/2$, $k=7$, (CCSDS recommended G1 inv) QPSK only
Scrambler	CCITT V.35 standard
Frequency	S-Band (1.8 to 2.)
Output	150mWrms
DC Power	5.2V @ 670mA (330mA idle)
Size	120 x 160 x 20mm
Mass	500g

Transmitter Overview

The transmitter is comprised of a data processing unit, a Controller Area Network (CAN) for TT&C, a frequency synthesiser, an I/Q modulator and power amplifiers.

Data Processing Unit

All data and clock inputs are fed through opto isolated inputs. These can be bypassed at build time if they are not required, as was done on SNAP to save power. The data and clock are then fed to a Xilinx “Cool-Runner” FPGA for data and clock multiplexing. There are a total of eight physical inputs for data and clock respectively. Addressing controls come from the CAN. The data source might be the On-Board Computer (OBC), which produces data and a synchronous clock. On a previous payload called Merlion, flown on UoSAT-12, problems were observed when data and clock were generated by separate modules due to differing time delays between clock and data signals.⁵ On SNAP this has been removed by ensuring that data and clock are generated by the same source. The transmitter receives these two and regenerates a local clock. This is done by taking the incoming clock and applying it to an internal Phase Locked Loop, implemented as a hybrid digital phase detector and an analogue loop filter resulting in a second order loop. This regenerated clock is then used to sample the incoming data into the FPGA.

The sampled data is then passed through a CCITT V.35 scrambler, implemented in the same FPGA. This is then fed to a NRZ-L to NRZ-M (Mark) differential encoder and then to a 1/2 rate, k=7 convolutional encoder.

The next operation is to shape the binary data into Nyquist baseband pulses with root-raised-cosine spectral distribution. This is for optimal noise performance using matched filtering.

The FPGA does this by taking the outgoing I and Q data streams and forms a Serial in, Parallel out (SIPO) that acts as an address byte to respective I and Q EPROMs that contain pre-calculated outputs for all 256 possible waveform trajectories. Another two bits on the address lines are a x1 and x2 clock, that enable four samples per bit period. The contents of the EPROM are created using proprietary software written using the MATLAB software package. An alpha of 0.6 is used, so as to minimise peak to RMS ratio of the generated waveform, thus allowing maximum undistorted RMS output power from the RF linear amplifier, helping to increase the RF to DC efficiency of the transmitter system. Below is a table showing the relationship between Alpha roll-off value and the Peak to RMS ratio.

Table 2. Alpha vs. Pk/RMS ratio

Alpha	[Pk/RMS] dB
0	6.68
0.1	6.36
0.2	5.33
0.3	4.5
0.4	3.56
0.5	2.88
0.6	3.05
0.7	3.05
0.8	3.08
0.9	3.5
1	3.54

It was decided that a value of 0.5 would be optimum, as it has the lowest Pk/RMS ratio. However, in practice 0.6 was chosen because of the availability of COTS receivers that happen to have built in roll-off factors of 0.6. This is of little consequence, as the difference between 0.5 and 0.6 is less than one dB, and the additional bandwidth used is negligible.

Operational Amplifier circuits are used for the anti-alias filtering, and due to the high sampling rate, the cutoff frequency can be quite high, minimising any affect on the amplitude or phase of the actual output spectrum, so temperature and component tolerances can be very loose, for maximum robustness. Analogue anti-alias filters were used for their very low power consumption and continuous time frequency response for a clean output spectrum.

I/Q Modulator

The analogue baseband I and Q channels are now fed to a RF Microdevices RF2422 I/Q modulator chip for direct up-conversion to S-Band. However, due to the small size and screening difficulties of such a small PCB, it was found to be optimal to offset the synthesiser to prevent the modulated BPSK signal from pre-modulating VCO output, only to be re-modulated again. This was a lesson learned from Merlion⁵. The offset frequency used is 240MHz. Use of buried Stripline transmission lines in the multi-layer PCB minimises stray coupling and helps maintain signal purity and minimise Error Vector Magnitude (EVM) of the transmitted signal..

Frequency Synthesiser

The S-Band signal is created using a Commercial Off-The-Shelf (COTS) VCO, and

National Semiconductor LMX2326 series of PLL. A stable TCXO was used as the reference oscillator. A discrete component oscillator was used with a seventh overtone miniature crystal to create the 240MHz offset frequency. The two outputs were mixed together through a passive mixer and passed through a ceramic block filter to remove the unwanted mixing products.

Power Amplifiers and Band-pass Filtering

The output from the I/Q modulator is then fed through a series of ceramic block band pass filters and power amplifiers. The output spectrum must be very clean and not contain any unwanted out-of-band spurs or

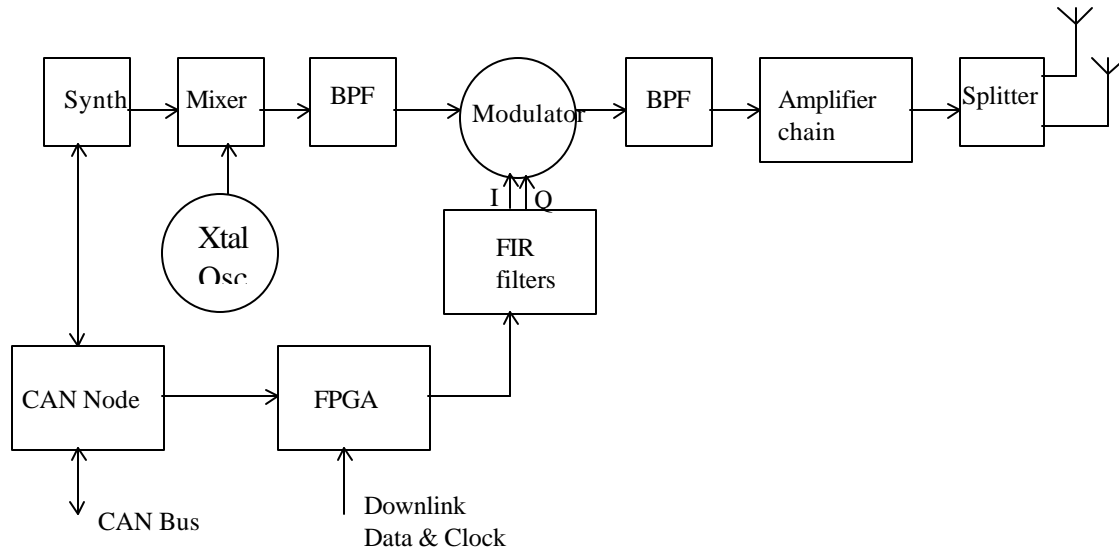

Figure 4. SNAP-1 S-Band Transmitter Block Diagram

distortion products, and must not contain appreciable noise at the corresponding S-Band uplink frequency band. Otherwise, white noise from the transmitter will overload and mask a sensitive S-Band uplink receiver (even though SNAP-1 does not have an S-Band uplink).

The driver and power amplifiers are RF2126's and require special attention. They are power devices that use a conductive base-plate to sink waste heat, and also serves as an RF ground. This bond for the flight units was established using conductive silver epoxy for efficient heat and electrical contact, without the need for risky and difficult to inspect soldering. The RF2126's have a current control pin, and this is used to implement a constant current source for the power amplifiers to prevent thermal runaway, and maintain performance over a wide temperature range.

The resultant output power is between 100 and 200mW, sufficient to drive an external Power amplifier to any desired output power, or directly to antennas for low data rate operation. When it is required, placing the high power amplifier externally provides excellent RF screening, thus preventing unwanted feedback and the problems that were encountered during

the design and construction of the Merlion payload.

ENABLING TECHNOLOGIES

There are several enabling technologies that have contributed to helping this module attain a high performance density, namely as follows:

- Modular Subsystems
- Reusable PCB
- In Circuit Re-programmable FPGA
- CAN
- DSP Methods
- Low-Cost wireless RF semiconductors
- Miniature Ceramic block Filters
- Flexible PCB Interconnects

These factors allow the module to be usable for most mission types, ranging from nanosatellites (<10kg), to microsatellites (<50kg), to enhanced microsatellites (<100kg) and minisatellites (<500kg).

Modular Subsystems

SNAP-1 is constructed of individual modules, as depicted in figure 5. It is possible to mix and match modules to achieve the desired combination of core sub-systems for a targeted level of function and reliability. Nanosatellites could be envisaged to consist of non-redundant systems, keeping the cost of each satellite to a minimum. However, other missions, such as a minisatellite might need greater mission reliability, so multiple transmitter units (for example) might be more appropriate.

Non-standard satellite missions and shapes can be more easily accommodated using modular systems, because they can be bolted together in a wide variety of combinations and orientations. This is a great advantage for speedy Mission Analysis and Design exercises.

The modular subsystems are also very amenable to being sold to other satellite builders who might wish to buy in the technology to get their satellite to completion more quickly, and with heritage.

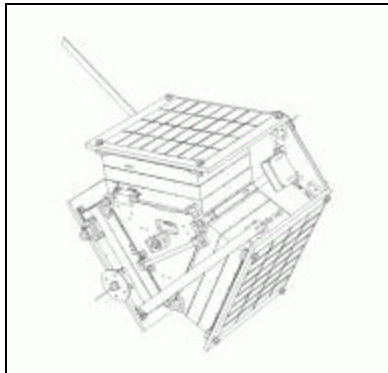

Figure 5 SNAP-1 is Comprised of Reusable and Interchangeable Modules

Reusable PCB

The S-Band transmitter is completely reusable for any mission, as it can be build-time configured to implement varying amounts of electronic options. For example it is possible to implement opto-isolation of all inputs and outputs. Whatever the mission requires, it is possible to reuse the same PCB for the application. This will save time and money because only one PCB type will need to be kept in stock, and will simplify PCB ordering as there is only one S-Band transmitter PCB version.

In-Circuit Re-programmable FPGA

All the data processing and logical interfacing is done through the use of a Xilinx “Cool Runner” XCR5128C FPGA. It has the advantage that it is re-programmable while in circuit. As a result, sockets are not required, and firmware modifications can be made right up until the last moment if changes are required. The devices hold their programming for over one hundred years, and can be re-programmed thousands of times. A block diagram of the particular FPGA implementation for SNAP-1 is shown in figure 6.

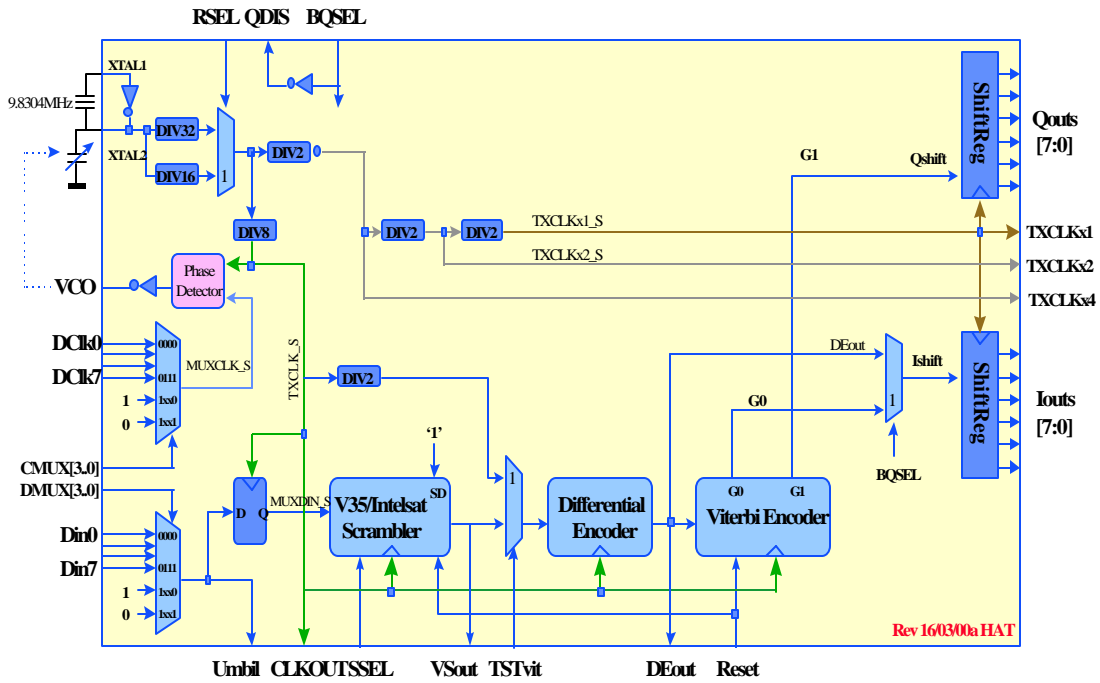

Figure 6. FPGA functional implementation as used for SNAP-1 S-Band Transmitter

The Xilinx XCR5128C FPGA forms the heart of the transmitter, and performs functions that would need a much larger, non-reusable PCB if implemented using discrete logic ICs. The software used to compile the code is called WebPACK by Xilinx.⁶

This series of “Cool-Runner” FPGA achieves very low power consumption through the clever use of dynamically only powering up gates when necessary to perform a logic function, on data or clock edges. This allows the chip to draw much less current than conventional FPGAs, and operate at very high speeds for a given level of heat dissipation. This technology however demands very tight control of input rise and fall times as a result, and how data is sampled must be considered carefully during the design process. False triggering edges can be produced as a result, causing erratic behaviour if not careful.

CAN (Controller Area Network)

The CAN system has been used by SSTL for several years now, and has been used on many missions. The device used in the S-Band transmitter is the C515C series by Siemens. There are versions of the C515C that contain ROM memory, and are one-time-programmable, or OTP. These take up the minimum possible PCB area, but tend to be expensive if there are

multiple revisions of firmware during development. As a result, the CAN controller uses relatively cheap, external EPROM to contain the firmware. This has the disadvantage of needing more PCB real-estate, but keeps the cost down and maximises mission to mission flexibility.

Controller Area Networks have been used on previous missions for distributed TT&C in the past, starting with FASAT-Alfa, and FASAT-Bravo, as well as UoSAT-12, and continue to function well in orbit.^{7,8} These CAN networks have very simple two-wire interfaces, and minimise the amount of wiring required between modules, thereby simplifying wiring and enhancing reliability. The simple TT&C interface facilitates automated testing routines, thereby speeding up test sequences and again saving time and money, as well as being technically more repeatable and therefore potentially better value for money to the customer.

DSP Methods

The simple implementation of basic DSP methods enables the SNAP-1 transmitter to generate perfectly formed root-raised-cosine Nyquist pulses. It would be difficult to achieve a high performance density in this module were

it not for the powerful capabilities of DSP methods in modem technology.

Low-Cost Wireless RF Semiconductors

The availability of microwave RF semiconductors for use at S-Band has made the design and implementation of the necessary circuitry relatively easy. These components are directly from the mobile phone and wireless LAN industry. The complete I/Q modulator from baseband to RF is all done inside one chip (RF2422), without any tuning or matching components at all. The RF amplifiers in the system (RF2301, 2306, and 2126) are all 50 Ohm gain blocks, that use minimal external matching components.

Miniature Ceramic block Filters

The availability of miniature low loss bandpass filters has made it possible to obtain very good spectral purity from very simple electronics. Low loss ceramic resonators can be used to implement narrow band, low insertion loss bandpass filters. Although possible to design and implement these in-house, they are difficult to implement in practice in an acceptable flight standard. It has been found that the mobile phone market makes extensive use of these passive components for the same reasons, and it is quite easy now to find several manufacturers offering such products. These filters tend to be very low-profile, surface mount technology, and with careful PCB layout can produce outstanding ultimate rejection out of band, which is critical to elimination out-of-band spurious emissions.

Flexible PCB Interconnects

The ability to make vibration proof flexible connections to the module box connectors has several advantages. Namely:

- Repeatability
- Reduced build time
- Improved EMC performance

New PCB fabrication methods allow the mixing of traditional FR4 material and Kapton based flexible circuit board substrates. By routing the connector via such flexible circuit board material, it is possible to completely remove the need for manual wiring, thereby saving time and money. Admittedly, the lead times and costs of a PCB with “flexi-leads” is about 50% greater, this is offset by the other advantages, such as repeatability and EMC performance, and the permanent absence of wiring errors. On the whole, flexi-pcbs reduce costs and time,

and allow mass-production methods to be used if required.

Acknowledgements

The authors would like to thank all the dedicated and talented staff and academics at SSTL who helped to design, manufacture and test the SNAP-1 spacecraft.



Figure 7. SNAP-1 undergoing final tests

Conclusions

The use of modular subsystems makes it possible to create spacecraft with a wide range of shape factors, and allows the mission analysis and design teams to create spacecraft that more accurately meet the requirements of the customer. Re-useable PCBs help to keep the costs down, and reduce the quantity of different PCBs that need to be kept in stock thus reducing overheads. FPGA's and CAN systems help to maximise system flexibility, again allowing the mission to be more accurately tailored to the customer's specifications for the mission. Low cost miniature electronic components from the mobile and wireless industry help to make the design and implementation of RF (and other) systems simple and quick, reducing design costs. Flexible PCB interconnects ensure module to module repeatability and enhance EMC performance.

It is now possible to design and build bespoke satellites to exacting specifications providing the customer with enhanced affordable access to space.

REFERENCES

1. Sweeting, M.N., "Space at Surrey—
Microsatellites and Minisatellites for
Affordable Access to Space."
Proceedings of the ESA Symposium
on Space Industry Co-operation with
the Developing World, 1997.
2. Cropp, A, "The 'SNAP-1' NanoSat Project
At Surrey - A New Generation Of
Satellites.' Proceedings of the 49th
International Astronomical Congress,
Melbourne, Australia September 1998
3. Sweeting M.N., et al, "Tsinghua - I, TMSAT
& TiungSat - I: New Satellites
Missions In The Asia Pacific Through
International Collaboration With
Surrey." Proceedings of the 49th
International Astronomical Congress,
Melbourne, Australia September 1998
4. Sweeting MN, et al, "Tsinghua
Micro/Nanosatellite Research and It's
Application." Proceedings of the 13th
Annual AIAA/USU Conference on
Small Satellites, Logan, UT, August
1999.
5. Chua, T.W., et al, "Merlion L & S Band
System," Proceedings of the 13th
USU/AIAA Conference on Small
Satellites, Logan, UT, USA, August
1999.
6. <http://www.xilinx.com/products/coolpld.htm>
7. <http://www.fasat.cl>
8. Ward, J.W. and M.N. Sweeting, "First In-
Orbit Results from the UoSAT-12
Minisatellite." Proceedings of the 13th
Annual AIAA/USU Conference on
Small Satellites, Logan, UT, August
1999.