

The SNAP-1 Machine Vision System

Richard Lancaster

Surrey Space Centre, University of Surrey, Guildford, Surrey, GU2 7QX, United Kingdom.
Email: r.lancaster@ee.surrey.ac.uk

Dr. Craig Underwood

Surrey Space Centre, University of Surrey, Guildford, Surrey, GU2 7QX, United Kingdom.
Email: c.underwood@ee.surrey.ac.uk

In June 2000, the Surrey Space Centre (SSC) and Surrey Satellite Technology Limited (SSTL) launched the remote inspection demonstrator nanosatellite, "SNAP-1". One of the primary mission objectives of this satellite was to image its companion microsatellite, Tsinghua-1, during the deployment phase of the launch. Later in the mission it is also planned that SNAP-1 will be manoeuvred back within visual range of Tsinghua-1, in order to carry out further imaging experiments whilst the satellites fly in formation.

To fulfill its mission, SNAP-1 carries a powerful, innovative and highly integrated Machine Vision System (MVS). This consists of four ultra-miniature CMOS video cameras, a "software" video digitiser, 8Mb of 70ns SRAM and a 220MHz StrongARM processor. The integration of these components provides a low cost, low power consumption, high reliability platform, with enough processing power to capture and process real-time video images. This will enable SNAP-1 to not only compress and return images back to Earth, but to perform high level computer vision functions such as optical target tracking, automatic pose and position estimation and on future SNAP missions perhaps even optically guided docking.

This paper therefore details the design, performance and initial results from the SNAP-1 Machine Vision System.

The SNAP-1 Machine Vision System (MVS) is a payload that was launched aboard the 6kg SSTL technology demonstrator nanosat, SNAP-1, in June 2000.

The SNAP-1 Spacecraft

SNAP-1 is a technology demonstrator designed to flight test the new miniature computer, navigation, propulsion and power systems that SSTL has designed for nanosat use. These flight tested systems can then confidently be used on future commercial SSTL nanosat missions. However while SNAP-1 is basically a technology test-bed, it was put together with the mission objective of acting as a "Remote Inspector" in mind.

A "Remote Inspector", in this context, is a spacecraft that can be deployed from a space station, mother satellite or launch vehicle. It can then manoeuvre around other spacecraft in its vicinity and relay TV quality images of those spacecraft back to a remote human observer. This could for example be useful for inspecting damage on the outside of space stations, or for checking that launch vehicles are correctly deploying their payload by filming the event from a "chase"

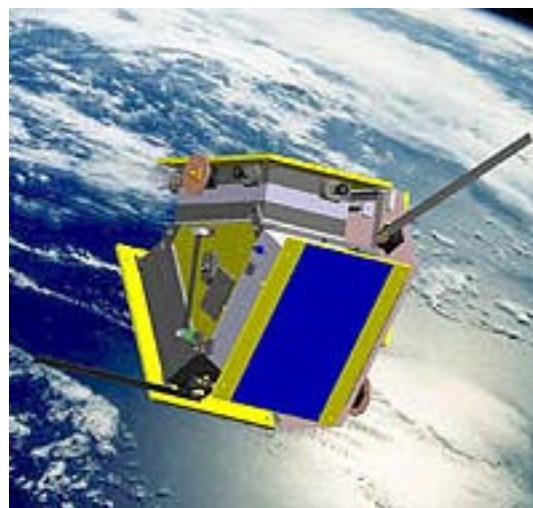

Figure 1: A computer illustration of the SNAP-1 spacecraft.

satellite that is deployed from the launcher a few seconds before the primary payload.

The Machine Vision System

The MVS payload is hence designed to enable SNAP-1 to act as a remote inspector. It does this

by providing a black box plug in solution containing all the necessary cameras and processing elements required to perform the remote inspection components of the mission. Hence the mission objective of the MVS is as follows:

"The purpose of the Machine Vision System (MVS) payload. Is to enable the SNAP-1 spacecraft, to obtain and relay to a remote human observer, TV quality images of other spacecraft in the local vicinity."

It would have been possible to achieve this mission objective, by implementing the MVS as a set of cameras connected to a frame grabber, which was under the control of the satellite's main On Board Computer (OBC). However it was decided that we would expand the range of possible mission profiles for the MVS, by including a large quantity of processing power on the MVS its self.

Therefore as this processing power is dedicated to MVS functions, it has the advantage of not being burdened with the spacecraft housekeeping roles that have to be performed by the OBC. The upshot of this is that the MVS has enough processing power to perform tasks such as real-time compression of video from the cameras for transmission over a low bandwidth RF link. Or given appropriate software, the MVS can potentially also perform high level vision functions, such as optically tracking other spacecraft, horizon sensing or automatically docking a future SNAP spacecraft with a mother-ship using only optical data.

The basic components that make up the MVS and allow it to perform its stated mission objectives are therefore as follows:

- Three wide angle 350 by 288 pixel CMOS cameras. Each with a 90-degree field of view, which together are arranged to cover a 270-degree arc of space.
- A single 350 by 288 pixel narrow angle camera, which points in the same direction as the central wide angle camera. This enables features to be selected and inspected in detail.
- Video digitiser circuitry to convert the composite video output by the cameras into digital data.
- 8Mb of 70ns SRAM for code and storage of images obtained from the cameras.



Figure 2: One of the miniature CMOS cameras used on the SNAP-1 MVS.

- A 220MHz StrongARM 1100 processor, for video/image compression or performing high level vision functions such as optical target tracking or automated optical docking.
- A CAN bus interface to talk to the rest of the spacecraft.

The "Software Digitiser"

The development of the SNAP-1 spacecraft was unusual and demanding in that there was only a six month period from the point that we realised that we had a launch opportunity, to the point at which we had to ship the spacecraft. Hence as SSTL had never built a nanosat before, this gave us six months to design, manufacture, integrate, test and ship a spacecraft composed entirely of new technologies. This was a major challenge to undertake, especially as due to component lead times and the short time scale we had to go directly from the design stage to building flight hardware, without ever building a prototype.

For the MVS board this presented us with a significant problem. This is because we had decided to use miniature CMOS cameras, which output composite video signals, so that we had a simple three-wire interface between the cameras and the MVS board. Now the conventional method of grabbing frames from a composite video signal is to use a collection of analog sync detectors and phase locked loops, to detect the sync pulses, trigger the digitiser and synchronise the clocks. However this type of analog technology needs prototyping, and as already mentioned we did not have time to do that.

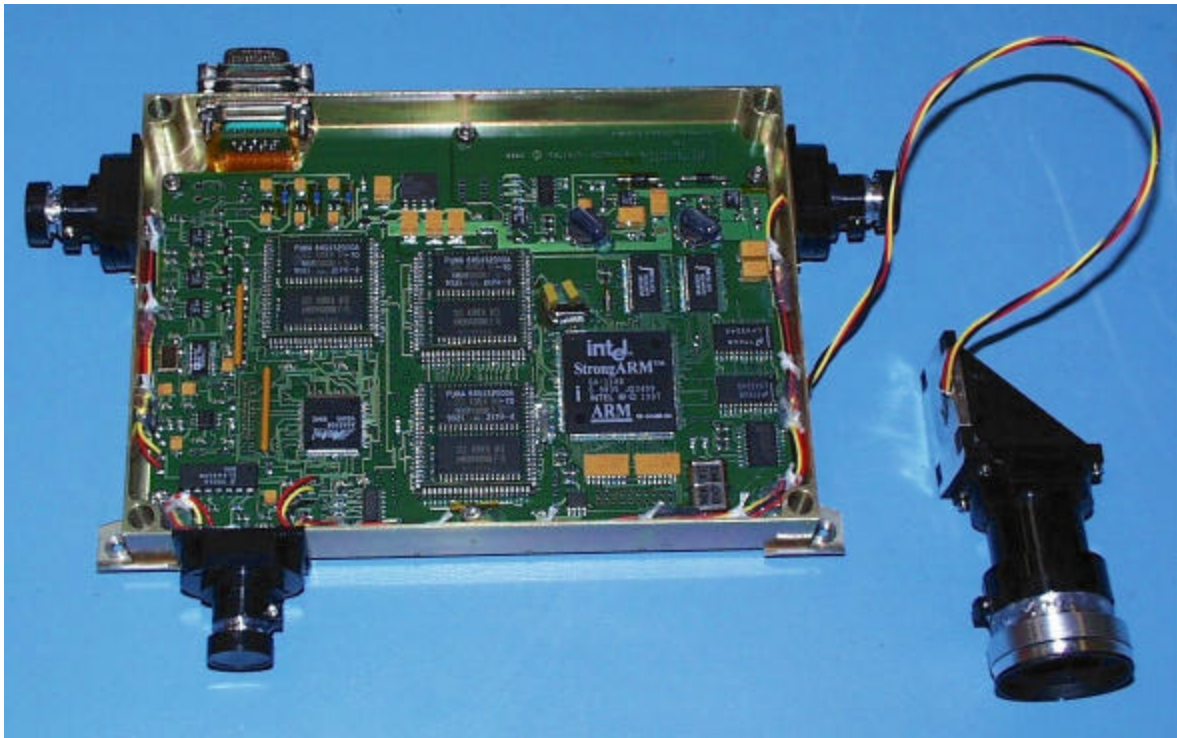

Figure 3: The flight model of the SNAP-1 MVS in its payload box. The three wide angle cameras can be seen attached to the sides of the box, and the narrow angle camera can be seen on the long flying lead that allows it to be mounted elsewhere on the spacecraft.

So to avoid the need to build a prototype we took rather a radical approach. We borrowed a methodology that has been used for a number of years in laptop modems. Basically instead of using hardware to decompose the composite video, we simply fed the video into an ADC and recorded the whole video stream, sync pulses and all. We then wrote software for the MVS's processor to scan the digital representation of the video signal, detect the sync pulses and extract the video data. Hence the only significant analog component on the MVS board is the ADC, and it is fairly easy to get that right without a prototype.

What we had therefore done was shifted the complexity of extracting the video data from the composite signal from analog hardware to software. Hence as the design, implement, test cycle for software is extremely short, we were confident that we were going to be able to achieve our aim in the time available, without a prototype.

This "software digitiser" design, also has a couple of added benefits:

- The component count on the board is reduced. Hence increasing the statistical reliability of the board.
- The processor can be programmed to handle the noisy or degraded signals that may be

encountered at some point in the on orbit mission. This would never be possible with standard analog electronics.

As clarification that the decision to go with a "software digitiser" was the correct one. The first hardware that we received from the manufacturers powered up and worked first time, even though we had not built a single prototype. In fact the time period between getting the first hardware on our desks and integration with the spacecraft was only ten days.

Internal Architecture

A block diagram of the internal architecture of the MVS payload is shown in Figure 4. This operates as follows:

- The cameras can each be individually turned on and off by the CPU.
- The composite video from each camera is fed into the front-end video MUX. The CPU can switch this MUX to select which camera to grab data from.
- The composite video from the selected camera is fed directly into the ADC and the entire video signal including sync pulses is digitised.

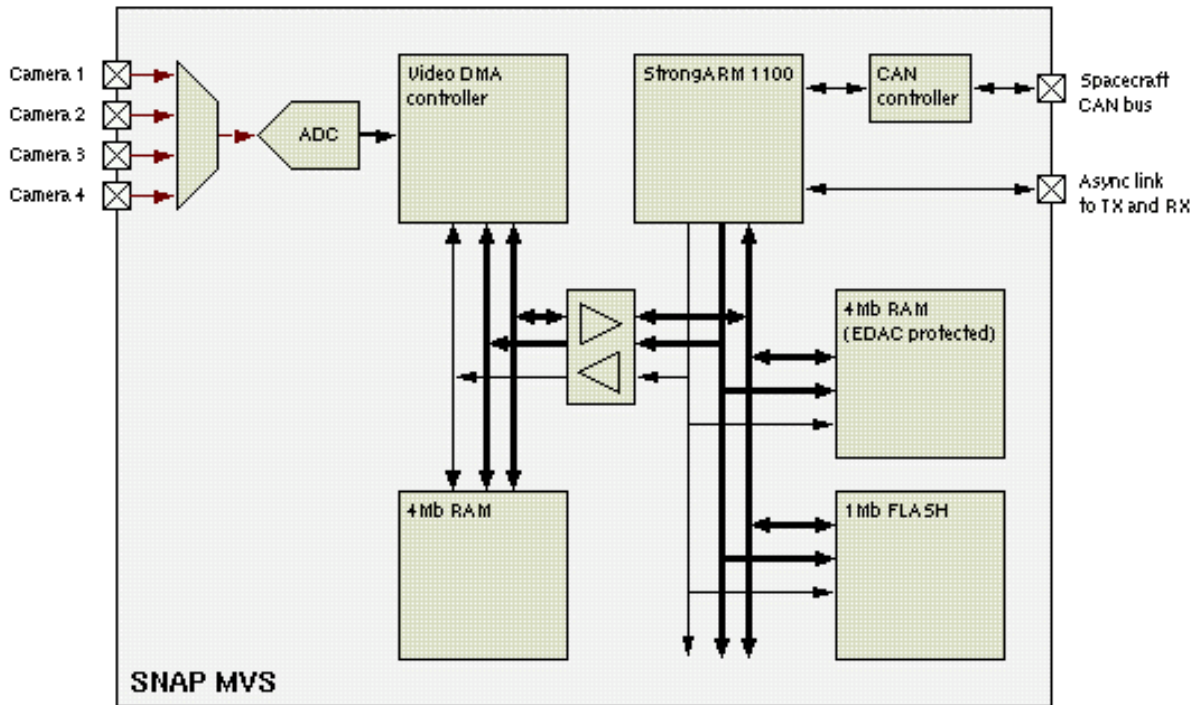

Figure 4: The internal architecture of the SNAP-1 MVS.

- The "Video DMA controller" can then be programmed to record a configurable length chunk of video data into the 4Mb of frame store RAM. While this is occurring the CPU can continue processing in its own block of RAM. This is made possible by the dual bus architecture and the bus divider between them.
- Once the DMA controller has captured the data the CPU can connect the two buses together and read the data out of the frame store.
- The CPU can then extract the video data from the composite signal, process it in whatever way is required (E.g. compression), and communicate it to the ground via the spacecraft CAN bus.

Software Architecture

The FLASH RAM on the MVS board contains only 10 Kbytes of code. This includes:

- An async bootloader that allows the upload of mission code once the spacecraft is in orbit.
- An autograb sequencer that is run on deployment. This grabs a 60 second time-lapse video from each of the cameras. Therefore obtaining a complete video of the deployment sequence.

Initial Results

At the time of writing the SNAP-1 spacecraft has only been in orbit for a few days. Therefore we are still downloading and processing the images obtained during the deployment. However Figures 5 and 6 show some of the images that we have so far obtained.

Conclusions

At this point in time the following mission milestones have been achieved:

- The SNAP-1 spacecraft was successfully launched and deployed.
- The power system woke up on deployment and turned on the MVS payload.
- The MVS payload booted into autograb mode and captured 60 seconds of time-lapse images from all four of its cameras.
- The images captured show in detail the complete deployment sequences of both the SNAP-1 and Tsinghua-1 satellites.

Therefore the MVS payload has so far performed exactly to specification. Over the coming months further on orbit operation will be carried out to

evaluate the performance of the MVS board. During which time horizon sensing and video compression will be implemented. Further results will then be forthcoming.

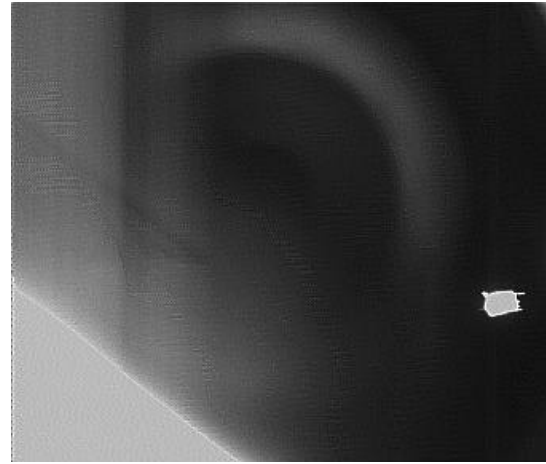

Figure 5: An image of the Tsinghua-1 satellite hanging above the Earth. This image was taken with the MVS's central wide angle camera 10.5 seconds after the SNAP-1 spacecraft deployed from the launcher.



Figure 6: An image of the limb of the Earth showing some surface detail. This image was taken with one of the MVS's side wide angle cameras 12.7 seconds after the SNAP-1 spacecraft deployed from the launcher.