

**21th Annual AIAA/USU Conference on Small Satellites
13-16 Aug 07**



Small Satellite Deployments From STS116 - Development Of New Manned Spaceflight Deployment Systems

***Perry G. Ballard, DOD Space Test Program
Albert Meza, DOD Space Test Program
Scott Ritterhouse, MEI Technologies, Incorporated
Theresa Shaffer, MEI Technologies, Incorporated
Carson Taylor, Oceaneering Space Services, Inc
David D. DeAtkine, Aerospace Corporation
James C. McLeroy, Aerospace Corporation
Carolynn Conley, MEI Technologies, Incorporated***



STP-H2 (CAPE/ANDE SSPL/RAFT MEPSI)

- **Purpose/Goals:**
 - STP developed hardware, FSE & GSE to deploy 3 SERB payloads: ANDE, RAFT & MEPSI
 - Inaugural flight of CAPE & SSPL5510
- **Specifics:**
 - Launch: STS-116, Dec 06
 - CAPE: 21" dia x54"
 - SSPL: deploys 5x5x10" volume
 - MEPSI: deploys 4x4x10" volume
 - Deploying on FD10 & 11





Atmospheric Neutral Density Experiment (ANDE)

- **Purpose/Goals:**
 - Determine total atmospheric density at low earth orbit altitudes
- **Specifics:**
 - 1-2 year life
 - Operational constraints
 - Lighting conditions
 - Deployment temperature
 - No thruster plume contamination
 - Eject over Maui
 - U.S. Space Surveillance Network (SSN)
 - Calibrate and validate existing assets
 - New analysis techniques
- **Benefits:**
 - Orbit determination
 - Degradation models
 - Collision avoidance techniques
 - Reboost maneuver optimization

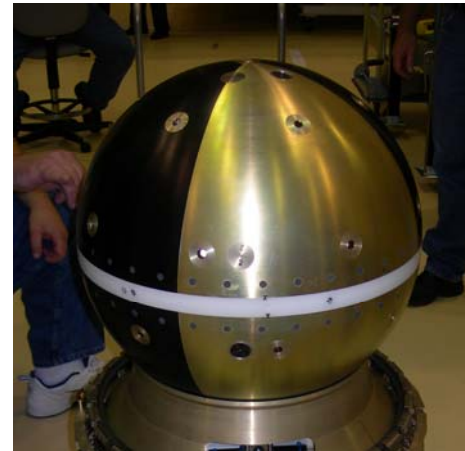

**Mock ANDE
Active**

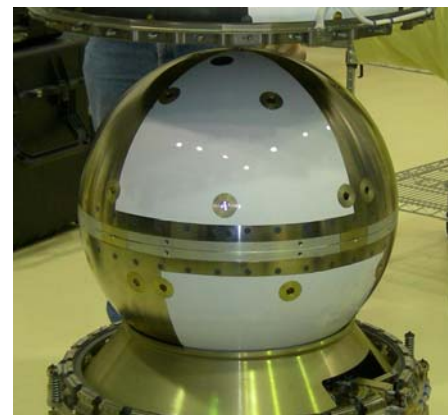

**Fence
Calibration**



Micro-Electromechanical system (MEMS)based Pico-Satellite Inspector (MEPSI)

- **Purpose/Goals:**
 - Demonstrate integration of MEMS/Nano-technology subsystems with decision-making architectures to enable radical new, low power, autonomous, on-board space systems in support of critical satellite operations
 - Provide proof-of-concept for capability of on-board “InfoBot” (<2kg) to provide visual inspection, servicing, and protection to host satellite
- **Specifics:**
 - Flown on STS-113 (Dec 02)
 - Each Picosat is approx. 4x4x5 inches and 1.5 kg
 - Tethered together (15 ft)
 - Launcher approx. 20 lbs
 - PicoSats approx. 8lbs
 - Manifested on STS-116 NET 14 Dec 06
 - Upgraded batteries & radios
 - Addition of Cameras and propulsion system on one picosat (“inspector”)
 - Xenon gas
 - Reaction wheels
- **Benefits:**
 - Inspector pico-satellites can send images of larger operational satellite
 - Damage assessment
 - Repair
 - Troubleshoot

Micro-Propulsion System

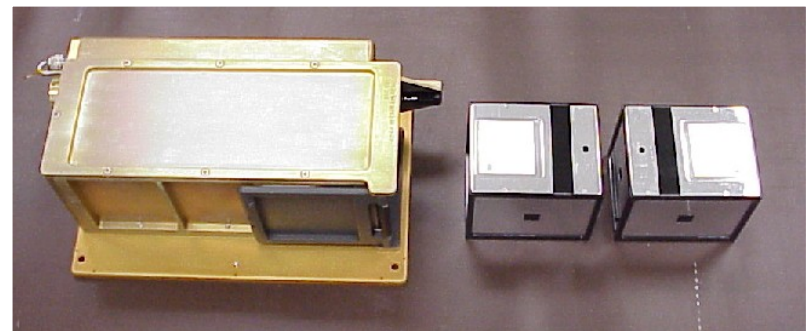
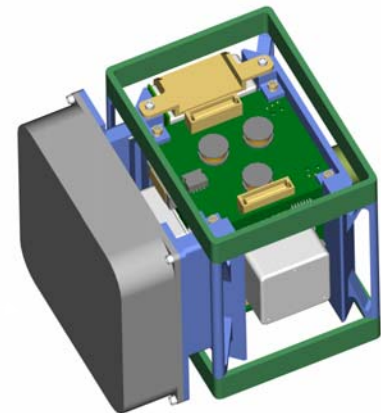



Radar Fence Transponder (RAFT)

- **Purpose/Goals:**
 - The experiment will use two picosats to calibrate the 218 MHz Space Surveillance (SSN) radar fence using an active radar transponder and enable tracking of clusters of small satellites for improved safety of flight collision avoidance.
- **Specifics:**
 - Each Picosat is approx. 5x5x5 inches
 - Magnetic Antenna Spools
 - Launcher approx. 20 lbs
 - PicoSats approx. 7kg
 - Manifested on STS-116 (Dec 06)
- **Benefits:**
 - Improve Radar Fence
 - United States Naval Academy (USNA) developing these satellites To educate midshipmen in space mission and satellite design and operations





STP-H2

EVA Training, Neutral Buoyancy Lab, JSC, Houston, TX



Build Up at Cape Canaveral



SmallSat 07 – SSC07-III-1

STP-H2

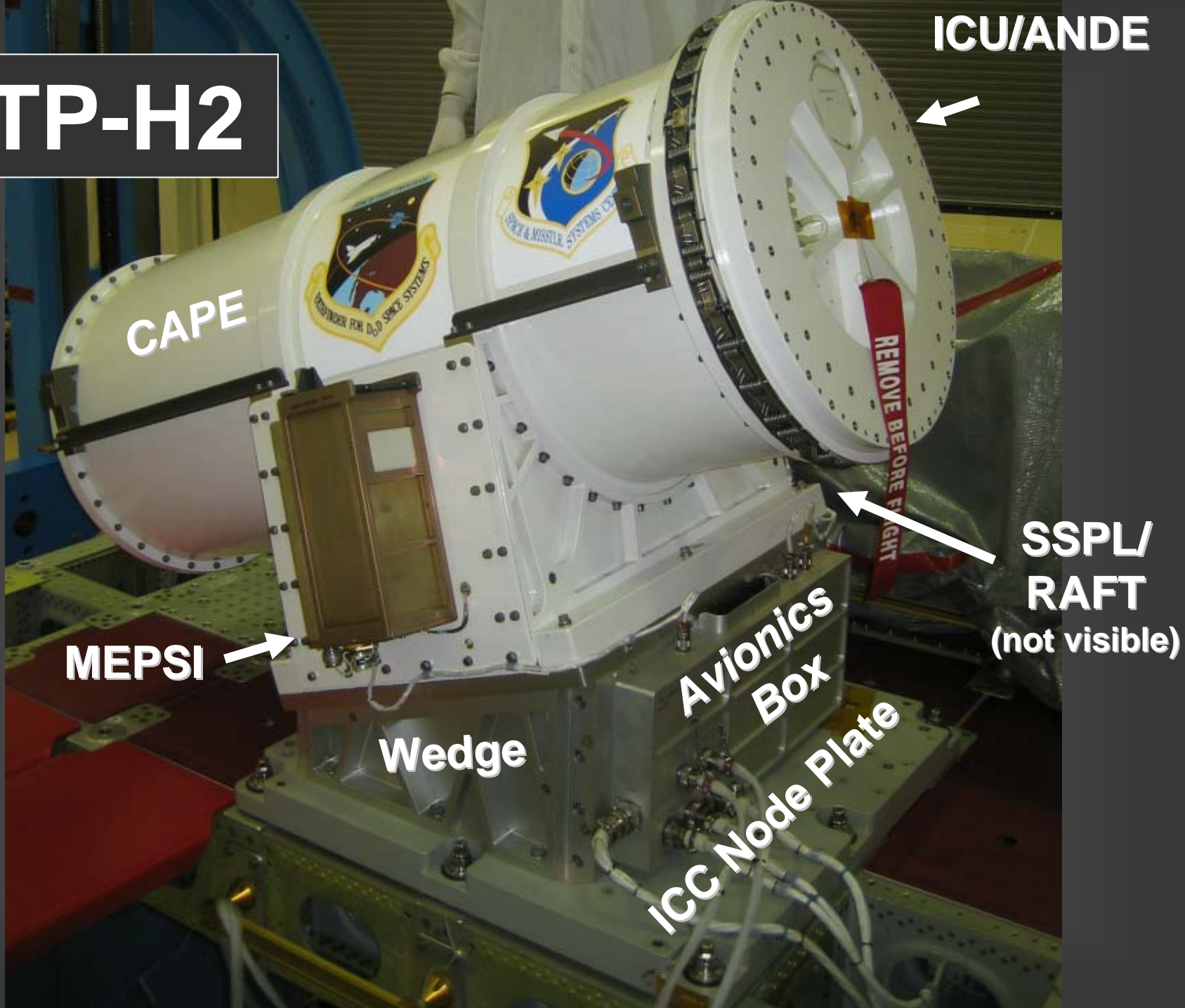



STP-H2 in Orbiter





SP-H2 on Orbit

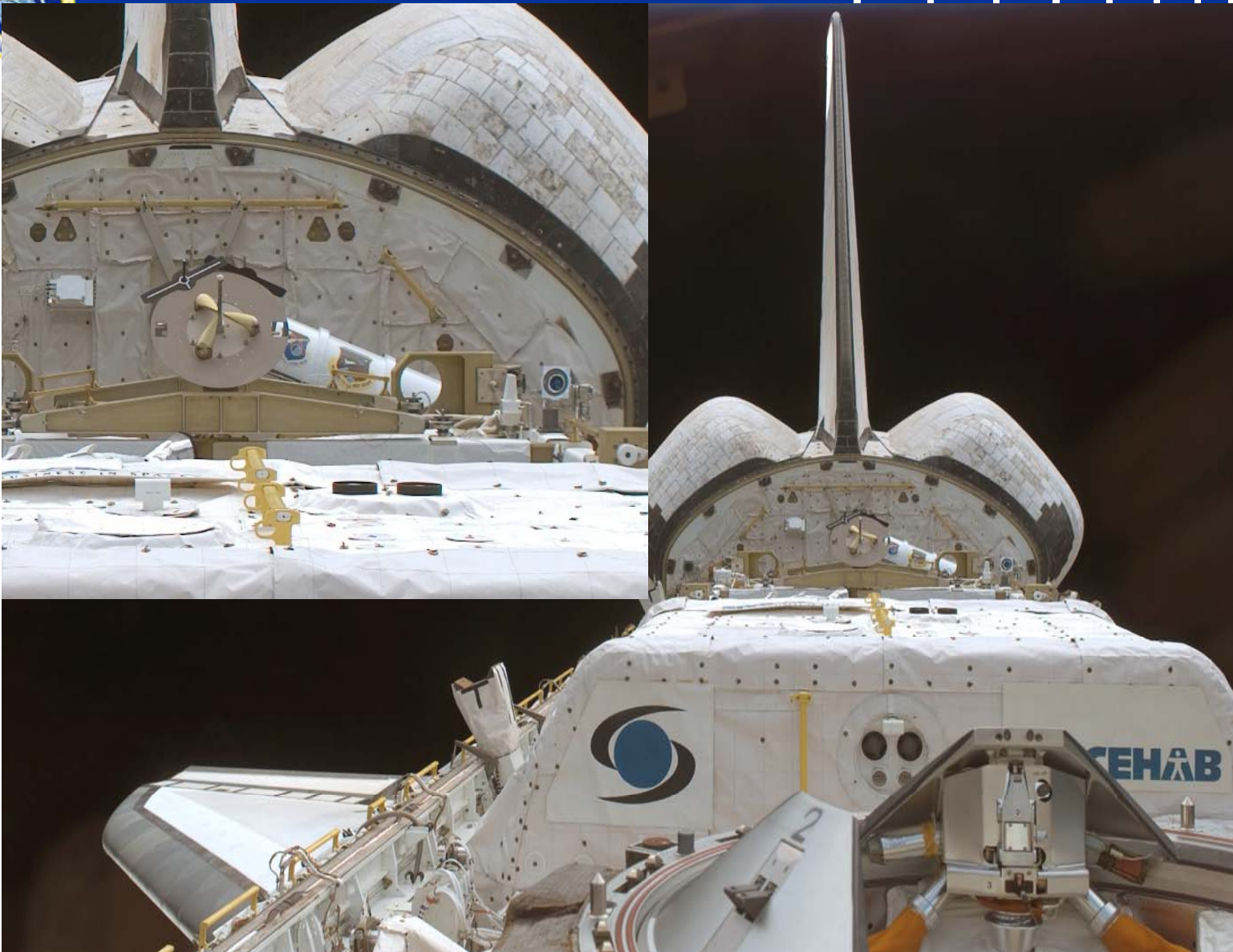



SP-H2 on Orbit



ISS014E09490
SmallSat 07 - SSC07-III-1



STP-H2 Deployments





STP-H2 Photos

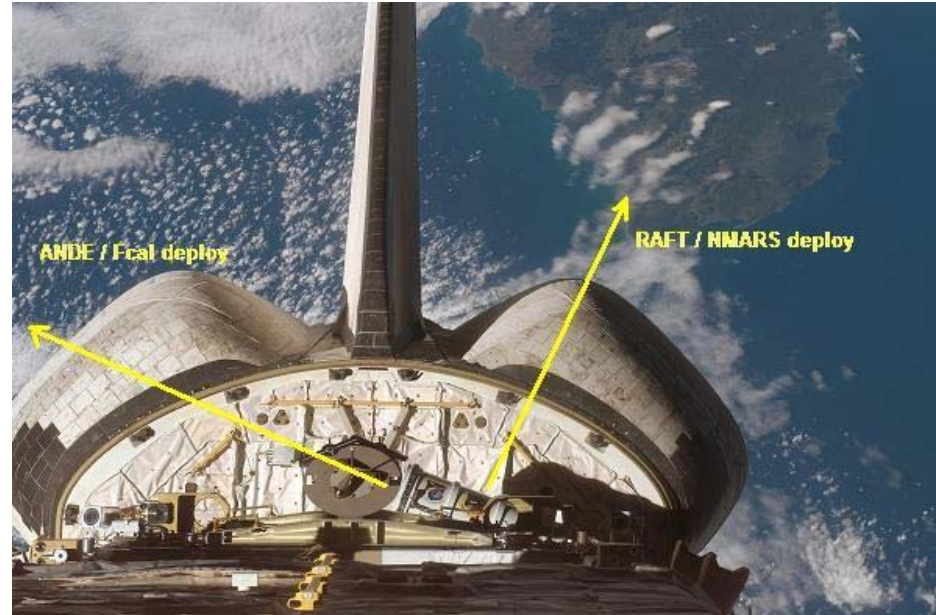

Shuttle as imaged by MEPSI
SmallSat 07 - SSC07-III-1



MEPSI assembly

STP-H2

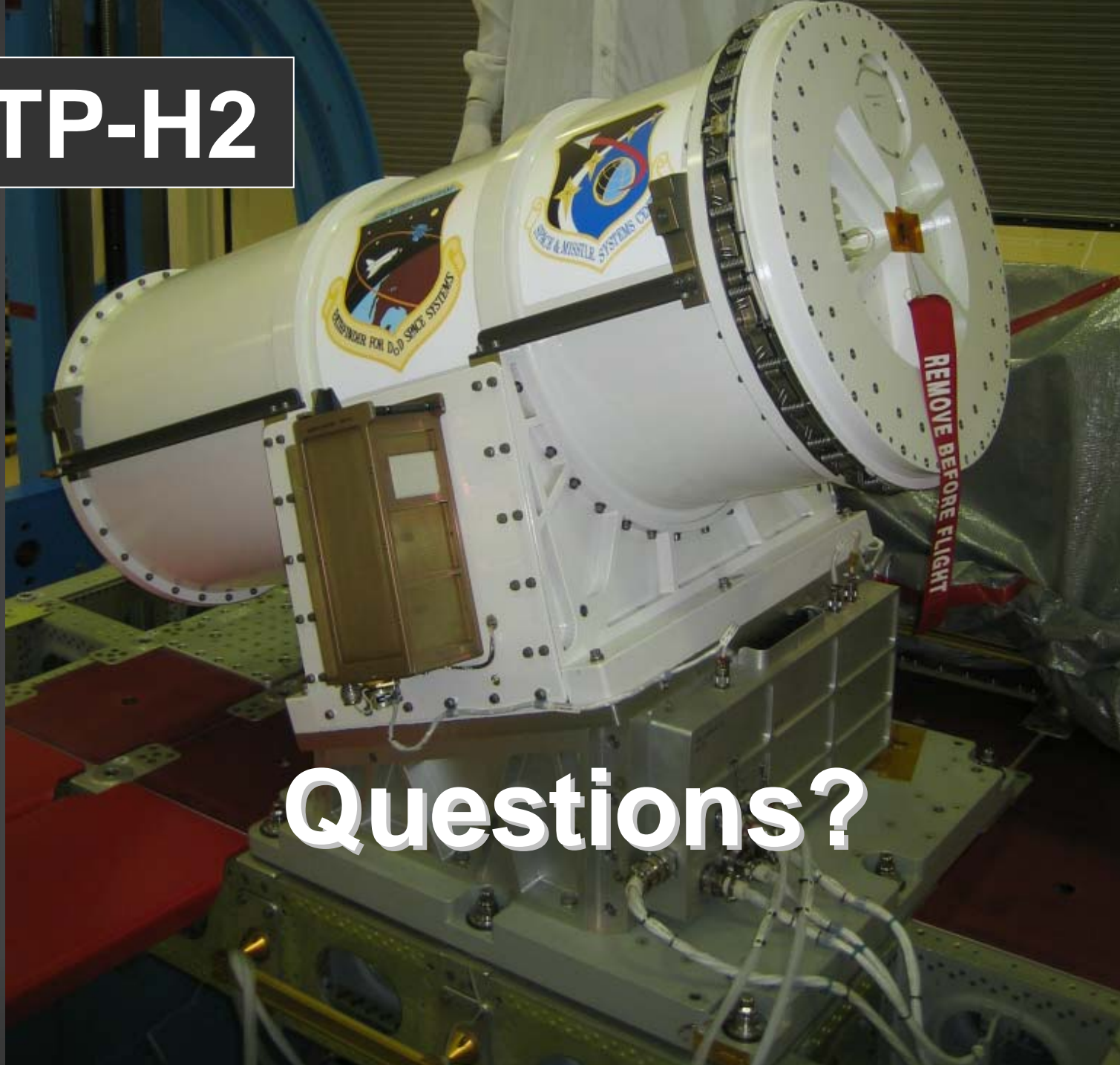

Questions?