

Utah State University

DigitalCommons@USU

Reports

Utah Water Research Laboratory

January 1973

Integrated Measurement of Soil Moisture by Use of Radio Waves

Duane G. Chadwick

Follow this and additional works at: https://digitalcommons.usu.edu/water_rep



Part of the [Civil and Environmental Engineering Commons](#), and the [Water Resource Management Commons](#)

Recommended Citation

Chadwick, Duane G., "Integrated Measurement of Soil Moisture by Use of Radio Waves" (1973). *Reports*. Paper 571.

https://digitalcommons.usu.edu/water_rep/571

This Report is brought to you for free and open access by the Utah Water Research Laboratory at DigitalCommons@USU. It has been accepted for inclusion in Reports by an authorized administrator of DigitalCommons@USU. For more information, please contact digitalcommons@usu.edu.



INTEGRATED MEASUREMENT OF SOIL MOISTURE
BY USE OF RADIO WAVES

By

Duane G. Chadwick

The work on which this report is based was supported in part with funds provided by the U.S. Department of the Interior, Office of Water Resources Research under P. L. 88-379, Project No. B-062-Utah, Agreement No. 14-31-0001-3657, Investigation Period--July 1, 1971 to September 30, 1973.

Utah Water Research Laboratory
College of Engineering
Utah State University
Logan, Utah 84322

November 1973

PRWG103-1

ABSTRACT

An integrated value of soil moisture can be determined by measuring the attenuation of vertically-polarized surface radio waves that are propagated over the ground between a transmitting and receiving antenna. Soil moisture values in the root-zone region were measured over longitudinal distances typically ranging from 50 feet to 600 feet with good results. Integrated soil moisture measurements over greater distances are also possible. The received field strength of propagated radio surface waves closely matches theoretical calculations. The measurement is easily made and does not disturb the soil. Dense, green vegetation, such as alfalfa or corn, causes errors in measurement accuracy. Less dense vegetation, such as range land, does not seriously affect measurement accuracy. The described equipment is portable and can be used by an unskilled operator.

ACKNOWLEDGMENTS

Acknowledgment is given to Joel E. Fletcher who originally suggested soil moisture might be measured by attenuation of radio waves. Ronney Harris assisted with some of the theoretical background work and Arlo Mickelsen assisted with broad aspects of the project in the early stages. Appreciation is also extended to John Hanks and Calvin G. Clyde who reviewed the manuscript and made helpful suggestions.

TABLE OF CONTENTS

| | Page |
|---|------|
| INTRODUCTION | 1 |
| METHODS OF DETERMINING SOIL MOISTURE | 3 |
| RADIO WAVE THEORY | 5 |
| Surface wave | 5 |
| Space wave | 8 |
| Skin depth | 9 |
| Effect of dielectric constant on radio wave propagation | 13 |
| MEASUREMENT PARAMETERS | 15 |
| Frequency determination | 15 |
| Antenna separation | 21 |
| Antenna height | 23 |
| INSTRUMENTATION | 25 |
| Antenna construction | 28 |
| Transmitter 170 MHz | 31 |
| Transmitter 27 MHz | 32 |
| Voltage regulator | 32 |
| Transmitter power monitor | 36 |
| Field strength meter | 36 |
| Power supply | 41 |
| EXPERIMENTAL RESULTS | 45 |
| Area of effect | 46 |
| Soil dielectrics (capacitor analogy evaluation) | 49 |
| Radio wave field strength versus applied water | 53 |
| Test site data | 55 |
| Effects of vegetation on field strength | 66 |
| Instrument calibration | 68 |
| Horizontal polarization | 69 |
| Comparison of 170 MHz data with 27 MHz data | 71 |
| Notes on operational procedures | 71 |

TABLE OF CONTENTS (Continued)

| | Page |
|---|------|
| SUMMARY | 75 |
| RECOMMENDATIONS FOR CONTINUED RESEARCH . . . | 78 |
| BIBLIOGRAPHY | 79 |
| APPENDIX I: SIGNAL STRENGTH CALCULATIONS. . . . | 80 |

LIST OF FIGURES

| Figure | | Page |
|--------|--|------|
| 1 | Attenuation coefficient (A) versus numerical distance (p) (Terman, 1943) | 7 |
| 2 | Calculated skin depth versus frequency for good (wet soil) earth and poor (dry soil) earth | 12 |
| 3 | Calculated ratio of field strength for good and poor earth (A_1/A_2) versus frequency (f) for four distances 8.6, 20, 34.6, and 80 wavelengths (d/λ) | 20 |
| 4 | Calculated ratio of field strengths for good and poor earth (A_1/A_2) versus distance (d/λ) for three frequencies, 30, 100, and 200 MHz | 22 |
| 5 | Block diagram of overall soil moisture measuring system configuration | 27 |
| 6 | Two antenna configurations used at 170 MHz | 29 |
| 7 | Field arrangement for operation by one operator | 30 |
| 8 | Photograph of 170 MHz transmitter, voltage regulator, and battery box | 33 |
| 9 | Photograph of 27 MHz transmitter, voltage regulator, power-VSWR meter, and battery box | 33 |
| 10 | Schematic diagram of a 1 1/2 watt continuous wave 27 MHz transmitter | 34 |
| 11 | Voltage regulator | 35 |
| 12 | A 170 MHz SWR and relative power meter | 37 |
| 13 | Schematic diagram of field strength meter | 39 |
| 14 | Power supply and voltage regulator circuit for the field strength meter | 42 |

LIST OF FIGURES (Continued)

| Figure | | Page |
|--------|--|------|
| 15 | Plan view of a wet field section located in the middle of a "dry" field | 47 |
| 16 | A plot of field strength versus antenna placement with respect to a wet strip of ground 16' wide x 100' long . | 48 |
| 17 | A plot of field strength versus antenna placement with respect to a wet strip of ground 25' wide x 50' long . | 48 |
| 18 | Plot and comparison of field strength between varying degrees of wet versus dry soil | 50 |
| 19 | Empirical determination that the received field strength is analogous to the soil dielectric | 51 |
| 20 | Plot of field strength versus inches of water applied over a 5 hour period | 54 |
| 21 | Range land showing typical vegetation growth and 170 MHz antenna used in tests | 56 |
| 22 | Green Canyon-North, range land with sparse vegetation | 57 |
| 23 | Green Canyon-North plot of soil moisture by gravity measurement versus electrical field strength . . . | 59 |
| 24 | Comparison of soil moisture (% by weight) and R. F. field strength | 60 |
| 25 | Green Canyon-South, range land with sparse vegetation | 61 |
| 26 | Grass plot on agriculture experiment farm | 62 |
| 27 | Green Canyon-South rangeland with grass and brush vegetation | 62 |

LIST OF FIGURES (Continued)

| Figure | | Page |
|--------|--|------|
| 28 | Rough plowed ground - Millville silt loam | 64 |
| 29 | Soil moisture varies 375 percent between tree line and center line between trees | 64 |
| 30 | Signal strength versus horizontal dipole antenna height above ground | 70 |
| 31 | Signal strength versus antenna height above ground for 1/4 wave vertical antenna | 70 |
| 32 | Plot showing comparison of 170 MHz versus 27 MHz signal strength | 72 |
| 33 | Estimate of relative costs of transmitter and field strength meter and trade offs possible between them . | 81 |
| 34 | A $\lambda/4$ antenna terminated in 50 ohms | 86 |

LIST OF TABLES

| Table | | Page |
|-------|--|------|
| 1 | Calculated values of phase angle, numerical distance, and attenuation coefficients at different frequencies and distances for both good and poor earth | 18 |
| 2 | Calculated space wave attenuation coefficient for various antenna heights | 24 |
| 3 | Record of precipitation in Cache Valley by months for long term average and for 1973 | 46 |

INTEGRATED MEASUREMENT OF SOIL MOISTURE

BY USE OF RADIO WAVES

INTRODUCTION

Numerous methods exist for determining soil moisture. All of the methods found in the literature discuss the measurement of soil moisture at a point or at least in a relatively small volume. To obtain a representative index of the moisture for an entire field, numerous points must be sampled. Numerous samples require considerable time, effort, and money. A more desirable soil measurement, in some instances, would be one that sensed soil moisture over a relatively large area and produced immediate soil moisture values. As a result of this need, an investigation of the use of radio waves was undertaken to determine the feasibility of their use in making an averaged or integrated soil moisture measurement.

In radio wave propagation, the groundwave depends upon the conductivity and dielectric constant of the earth it is transversing. These two electrical properties of soil vary with soil moisture. Utilizing this fact, soil moisture may be determined by measuring the relative intensity of a radio wave. The purpose of this research was to determine the feasibility of measuring soil moisture using radio wave propagation and to investigate the variables and problems

encountered in making such a measurement.

Sommerfeld (1909) was the first to obtain a solution for the field produced by a vertical antenna on the earth's surface. His remarkable piece of original work was largely unrecognized for about 20 years, at which time Sommerfeld's equations were found useful for predicting broadcast antenna radiation effectiveness. His work demonstrated, for example, that maximum propagation for a given transmitter output was obtained if the antenna was placed over wet, swampy soil. Sommerfeld's equations and subsequent work of others, including Norton (1936) who simplified the equations into a more usable form, have aided greatly in establishing a sound theoretical basis for this project.

In this report, brief comments are first made as background concerning some of the more common ways in which soil moisture is measured. These comments are followed by a presentation of the theory of "integrated" measurements of soil moisture. The third section concerns measurement parameters and establishes the basic configurations to be used. The next section discusses details of instrumentation, and this is followed by a discussion of measurement variables and their effects. The last major section of the report presents experimental measurements and comments pertaining thereto followed by conclusions.

METHODS OF DETERMINING SOIL MOISTURE

There are many methods of measuring soil moisture based on different physical principles. Ballard (1970) compiled a comprehensive study of the methods of measuring moisture and put them in the following categories: Hydrometric, electrical resistivity, capacitance, nuclear, gravimetric, radiation, tensiometry, thermoconductivity, and miscellaneous. Almost all the methods are point or small, restricted-area measurements. Present methods also require a substantial amount of time to obtain the measurement. For example, the gravimetric method, which was used as a calibration standard on this project, requires that numerous soil samples be taken. These soil samples must be carefully weighed and then dried in an oven for several hours and then they are reweighed. The loss in weight represents the water that was present. The percent of soil moisture is found by determining the difference between the wet soil sample weight and the dried soil sample weight, then dividing the difference by the dry weight and multiplying by 100.

No further attempt is made herein to describe any of these methods in detail, as this information is not germane to this particular project and more complete information can be obtained elsewhere. Each method cited by Ballard measures soil at a particular point or small volume in the field and almost all methods either require a soil

sample from the test site or require a quasi-permanent installation of equipment. The soil moisture measuring method described herein does not require a soil sample, does not measure moisture at a point, nor does it require a permanent installation of equipment.

RADIO WAVE THEORY

As stated in the introduction, there is a theoretical basis wherein soil moisture might be measured in a large-scale, instantaneous, convenient manner. Before discussing measurement details, the theoretical basis is presented showing why the system works.

Surface wave

Near the surface of the earth a radio wave is composed of two components, a surface wave and a space wave. The surface wave propagates with its lower edge in contact with the ground and can, therefore, only be vertically polarized since any horizontal electric field is short-circuited by the earth.

Power from a surface wave is dissipated in the earth's crust depending upon the characteristics of the soil over which the wave is propagating. Charges are induced in the earth due to the vertically polarized electric field of the surface wave. These charges induce a current flow through the earth which behaves like a leaky capacitor and can be represented by a resistance shunted by a capacitance (Terman, 1955). Based on this analogy, the electrical characteristics of the earth can be expressed by a conductivity σ and a dielectric constant ϵ . Power is dissipated by the induced current flowing through the earth's resistance. This power loss accounts for the attenuation of

the surface wave as it propagates.

Mathematical expressions describing the nature of the surface wave, first given by Sommerfeld, are discussed by Norton (1936). For an earth assumed flat, the surface wave field strength can be expressed by

$$\text{Field Strength} = A \frac{E_o}{d} \dots \dots \dots (1)$$

in which

E_o = field strength of wave at the surface of the earth at a unit distance from the transmitting antenna, neglecting earth's losses

d = distance from transmitting antenna

A = attenuation coefficient due to ground losses

The factor A is expressed by the curves in Figure 1. The numerical distance p for a vertically polarized wave is found by the relations

$$p = \frac{\pi d}{x\lambda} \cos b \dots \dots \dots (2)$$

$$\tan b = \frac{\epsilon_r + 1}{x} \dots \dots \dots (3)$$

in which

$$x = 1.80 \times 10^{12} \sigma/f$$

$$\frac{d}{\lambda} = \text{distance in wavelengths}$$

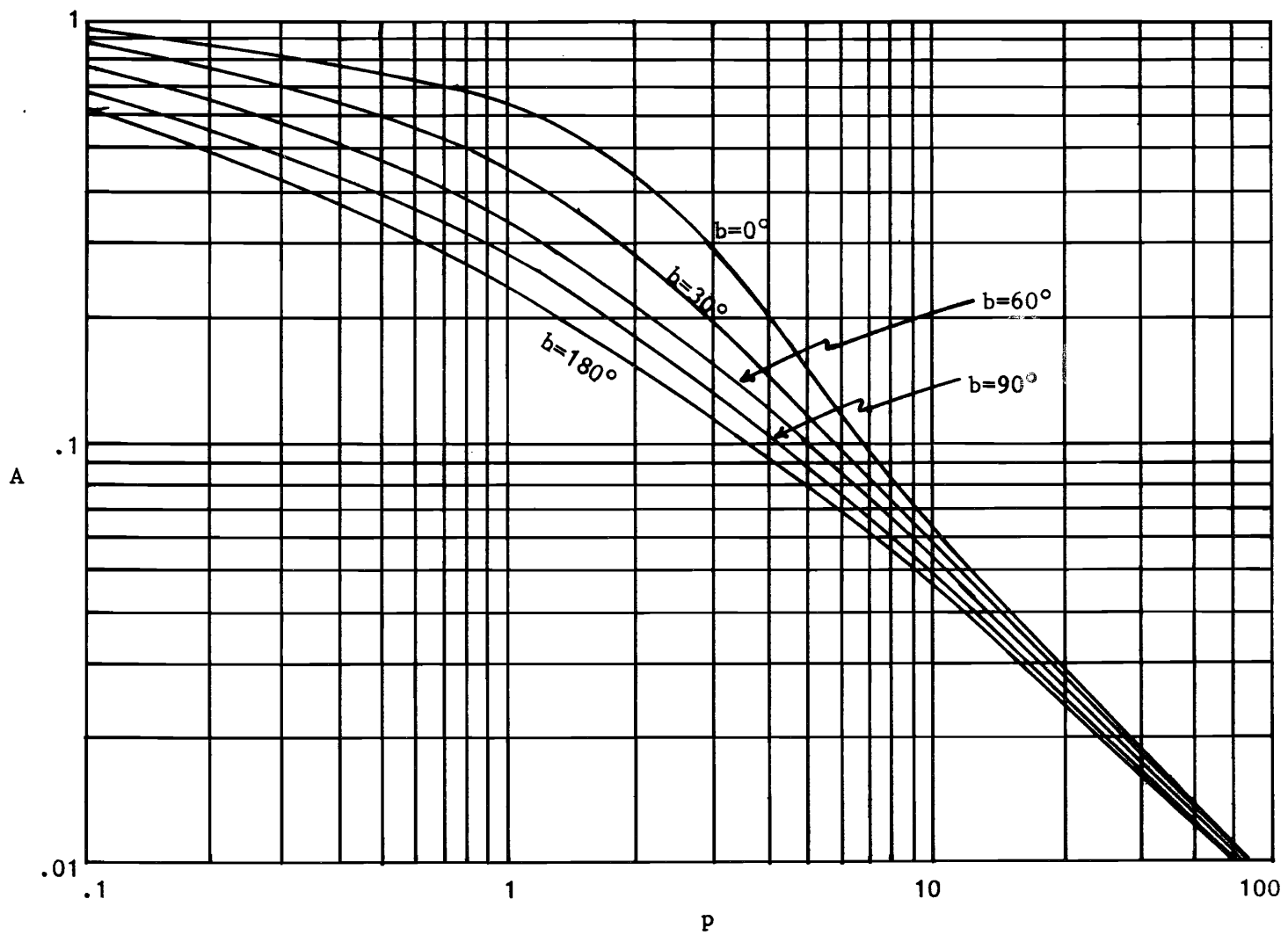

Figure 1. Attenuation coefficient (A) versus numerical distance (p) (Terman, 1943).

σ = ground conductivity in mhos per cm

f = frequency in hertz

ϵ_r = dielectric constant of the ground referred to air as unity

For $b \leq 90^\circ$, the curves in Figure 1 can be expressed approximately by the relation (Terman, 1943)

$$A \approx \frac{2 + 0.3p}{2 + p + 0.6 p^2} - \sqrt{\frac{p}{2}} e^{-\frac{5p}{8}} \sin b \quad . \quad . \quad . \quad (4)$$

The factor A is shown by Equations (2), (3), and (4) to be dependent upon the conductivity and dielectric constant of the earth, the frequency, and the distance from the transmitting antenna.

Space wave

The space wave is the second component of the radio wave of interest and is the vector sum of two separate waves. One is a direct wave between the transmitting and receiving antennas, and the other is a wave reflected by the surface of the earth before reaching the receiving antenna.

If the heights of the transmitting and receiving antennas are small compared with the distance between the antennas, the angle of incidence of the reflected wave is small, and the two waves will be equal in amplitude but will differ in phase. This is due to the fact that the reflected wave will travel essentially the same distance as the direct wave giving it the same magnitude, but will undergo a

phase shift due to the reflection from the ground. Under these conditions, the field strength of the space wave can be expressed as

$$\text{Field Strength} = \frac{2 E_o}{d} \sin \frac{2\pi hrhs}{\lambda d} \quad . \quad . \quad . \quad . \quad . \quad . \quad (5)$$

in which

- E_o = strength of the direct wave at unit distance
 d = distance between transmitting and receiving antennas
 λ = wavelength, same units as d
 h_s, h_r = height of transmitting and receiving antennas, same units as d

Examination of Equation (5) shows that the field strength of the space wave will be very small and probably negligible, compared to the surface wave, provided the antenna heights h_r and h_s are small in relation to the distance between the antennas.

Skin depth

Current flow in a conductor at radio frequencies is distributed so that most of the current flows near the surface of the conductor. This is because the inductance, and therefore, the impedance, is less near the surface than it is deeper in the conductor where more magnetic flux lines are linked with current flow (Terman, 1955).

With the surface of the conductor at the $Y = 0$ plane, the current distribution in the Y direction will be given by (Jordan, 1950)

$$i = i_0 e^{-\gamma y} \quad (6)$$

in which i_0 = current density at the surface

$$\gamma = \sqrt{j\omega\mu(\sigma + j\omega\epsilon)}$$

Since the attenuation of current with depth is of chief interest, only the real part of γ is used. This is called the attenuation constant α .

Therefore Equation (6) is rewritten as

$$i = i_0 e^{-\alpha y} \quad (7)$$

The skin depth is the depth at which the current density is $1/e$ or 37 percent of the surface current density i_0 . This would appear to occur at a depth of $1/\alpha$ as can be seen from Equation (7). From Jordan (1950) the attenuation factor is derived and can be expressed by

$$\alpha = \omega \sqrt{\frac{\mu\epsilon}{2} \left(-\sqrt{1 + \frac{\sigma^2}{\omega^2\epsilon^2}} - 1 \right)} \quad (8)$$

in which

$$\mu = \text{permeability of free space} = 4\pi \times 10^{-7} \text{ henrys/meter}$$

$$\epsilon = \frac{1}{36\pi \times 10^9} \text{ farads/meter}$$

$$\sigma = \text{expressed in mhos/meter}$$

Using Equation (8) the skin depth can be calculated for any frequency and soil condition. For "good" earth, with conductivity

$\sigma = 10^{-4}$ mhos per cm and a relative dielectric constant $\epsilon_r = 15$, and "poor" earth, with $\sigma = 2 \times 10^{-5}$ mhos per cm and $\epsilon_r = 5$, as defined by Terman (1943) the skin depths are plotted as a function of frequency in Figure 2. As can be seen from the curves, the skin depth becomes independent of frequency above 30 MHz. From this analysis, it appears that the skin depth in soil would be difficult to control by varying the frequency of the propagating wave.

Care should be exercised in interpreting the data shown in Figure 2. Its chief purpose is to show that depth of penetration is not very dependent on frequency. The depth of penetration is calculated with values of permeability equal to that of air. The presence of trace amounts of ferrous material will reduce the depth of penetration by the square root of the actual value of permeability compared to unity (reference value for air). Perhaps, more importantly, reflections from boundary layers beneath the earth's surface exist, since the earth's surface is heterogeneous. Any reflections that do occur reduce the depth of penetration of the radio wave.

For these reasons it is difficult to give a quantitative value of the depth of influence of the propagated wave; however, the depth of penetration is shown to be no greater than that indicated in Figure 2. From practical measurement experience, the system was shown to be chiefly sensitive to the top 3-4 feet of the earth's surface. This is due chiefly to the tendency for deeper soils to have a more or

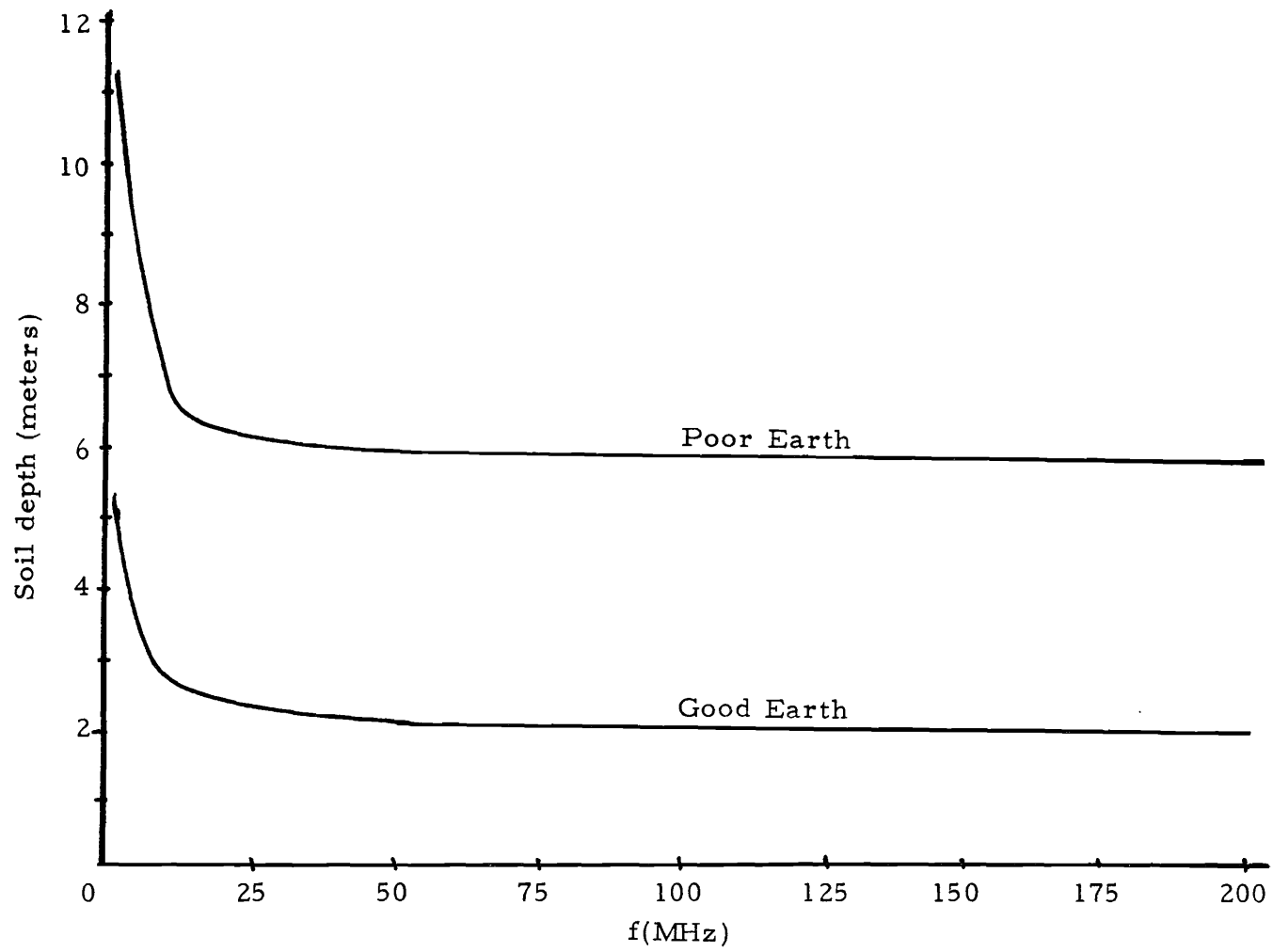

Figure 2. Calculated skin depth versus frequency for good (wet soil) earth and poor (dry soil) earth.

less constant degree of wetness and also the ever lessening influence of the soil which is not more nearly "in the path" between the antennas.

Effect of dielectric constant on
radio wave propagation

According to Josephson and Blomquist (1958) the dielectric constant of soil is determined mainly by the moisture content and is relatively independent of the type of soil. Therefore, soil moisture measurements could best be made for a dielectric earth where conductivity, which is dependent upon other soil properties besides moisture, would have a negligible effect upon surface wave attenuation.

Jordan (1950) considers a material a good dielectric when $\sigma/\omega\epsilon \ll 1$. This is true for most soils for frequencies above 100 MHz. Terman (1955) defines the numerical distance p , which can be used in Equation (4) to find the surface wave attenuation factor A , for a dielectric earth by

$$p = \left(\pi \frac{d}{c} \right) \left(\frac{f}{\epsilon_r + 1} \right) \cdot \cdot \cdot \cdot \cdot \cdot \cdot \cdot \cdot \quad (9)$$

in which

d = distance from transmitting antenna

c = velocity of light

f = frequency

ϵ_r = dielectric constant of the ground referred to air as unity

p in Equation (9) is dependent upon ϵ_r and no other soil properties

MEASUREMENT PARAMETERS

Before soil moisture measurement experiments can be conducted which would have reasonable chances of success, there are several parameters that should be studied. Optimal conditions or compromises should be determined for best results. Those parameters of chief concern include: Frequency of operation, the antenna separation, and the optimal placing of the antenna, in elevation, for maximum effect.

Frequency determination

Considering the wide range of frequencies over which radio wave propagation is possible, the selection of an optimum frequency for radio wave measurement of soil moisture was investigated.

There are several factors affected by frequency that must be considered. One is the separation distance between transmitting and receiving antennas. If very low frequencies are used, the antenna separation may have to be in the order of miles to eliminate the effects of the unwanted near (induction) field. On the other extreme, frequencies approaching the microwave region necessitate an antenna separation so small that the intent of obtaining an integrated measurement of soil moisture over a reasonably large area would be defeated. Antenna size is another factor dependent upon frequency. The antenna should be small enough to be portable; the higher the frequency the

shorter the antenna. Another factor regarding frequency selection concerns the ratio of field strengths of signals propagated over dry and wet soil, since this is also a function of frequency.

The field strength, as a function of frequency, was determined theoretically. Parameters for good and poor earth (wet and dry soil) were taken from Terman (1943), with conductivity $\sigma = 10^{-4}$ mhos per cm and relative dielectric constant $\epsilon_r = 15$ for good earth and $\sigma = 2 \times 10^{-5}$ mhos per cm and $\epsilon_r = 5$ for poor earth. Using Equation (1) the field strength ratio would be expressed by

$$\text{Field Strength Ratio} = \frac{A_1 \frac{E_o}{d}}{A_2 \frac{E_o}{d}} \dots \dots \dots (11)$$

This relation is correct if the space wave is negligible compared to the surface wave leaving the surface wave as the only component.

Since the reference field strength E_o and the antenna separation d are the same for both poor and good earth, Equation (11) reduces to

$$\text{Field Strength Ratio} = A_1/A_2 \dots \dots \dots (12)$$

in which

A_1 = attenuation coefficient over good earth

A_2 = attenuation coefficient over poor earth

A_1 and A_2 can be calculated, for a given frequency and the appropriate σ and ϵ , using Equations (2), (3), and (4).

Examination of Figure 1 shows that the attenuation coefficient A differs only slightly from unity for $p < 1.0$. The losses in the earth then will have little effect upon the surface wave. For the factor A to vary for different soil conditions, the relation $p > 1.0$ must be satisfied.

Table 1 lists the values of the numerical distance p and the phase constant b for various frequencies, for two soil conditions, and at four different antenna separations, 8.6,¹ 20, 34.6,¹ and 80 wavelengths. Examination of Table 1 shows that p and b approach constant values at frequencies above 30 MHz.

Figure 3 is a plot of the ratio of field strengths for good and poor earth versus frequency for the four antenna separations mentioned previously. The peaks seen at the low frequency end are due to the changes in slope of the curves in Figure 1 for various values of b in the region $1.0 \leq p \leq 10$. For frequencies above 30 MHz, the field strength ratio stays nearly a constant value.

A frequency of approximately 170 MHz was used for the operating frequency for several reasons. It occurred in the hydrologic T/M band and gave a good field strength ratio as shown in Figure 3. Antennas for this frequency are of a reasonable size to be portable. Equipment

¹ A separation of 34.6 wavelengths corresponds to 200 feet at 170 MHz where some preliminary measurements were made; later 8.6 wavelengths (50 feet) were used for most of the analysis.

Table 1. Calculated values of phase angle, numerical distance, and attenuation coefficients at different frequencies and distances for both good and poor earth.

| Distance = 8.6 wavelengths | | | | | | |
|----------------------------|-------------|------|----------------|-------------|------|----------------|
| Frequency (MHz) | Good Earth | | | Poor Earth | | |
| | b (degrees) | p | A ₁ | b (degrees) | p | A ₂ |
| 1 | 5.1 | 0.15 | .900 | 9.5 | 0.74 | .650 |
| 5 | 23.9 | 0.69 | .550 | 39.8 | 2.88 | .180 |
| 10 | 41.3 | 1.13 | .400 | 59.1 | 3.85 | .135 |
| 30 | 69.5 | 1.57 | .230 | 78.7 | 4.41 | .105 |
| 50 | 77.3 | 1.65 | .210 | 83.2 | 4.44 | .010 |
| 100 | 83.5 | 1.70 | .205 | 86.5 | 4.58 | .095 |
| 150 | 85.8 | 1.67 | .208 | 87.7 | 4.52 | .097 |
| 200 | 86.8 | 1.68 | .207 | 88.3 | 4.45 | .098 |

| Distance = 20 wavelengths | | | | | | |
|---------------------------|-------------|------|----------------|-------------|-------|----------------|
| Frequency (MHz) | Good Earth | | | Poor Earth | | |
| | b (degrees) | p | A ₁ | b (degrees) | p | A ₂ |
| 1 | 5.1 | 0.35 | .75 | 9.5 | 1.72 | .430 |
| 5 | 23.9 | 1.60 | .34 | 39.8 | 6.70 | .088 |
| 10 | 41.3 | 2.62 | .20 | 59.1 | 8.96 | .060 |
| 30 | 69.5 | 3.67 | .12 | 78.7 | 10.26 | .049 |
| 50 | 77.3 | 3.84 | .115 | 83.2 | 10.33 | .049 |
| 100 | 83.5 | 3.95 | .11 | 86.5 | 10.65 | .045 |
| 150 | 85.8 | 3.88 | .11 | 87.7 | 10.50 | .046 |
| 200 | 86.8 | 3.90 | .11 | 88.3 | 10.36 | .046 |

| Distance = 34.6 wavelengths | | | | | | |
|-----------------------------|-------------|------|----------------|-------------|-------|----------------|
| Frequency (MHz) | Good Earth | | | Poor Earth | | |
| | b (degrees) | p | A ₁ | b (degrees) | p | A ₂ |
| 1 | 5.1 | 0.60 | .72 | 9.5 | 2.98 | .270 |
| 5 | 23.9 | 2.76 | .24 | 39.8 | 11.60 | .050 |
| 10 | 41.3 | 4.54 | .115 | 59.1 | 15.50 | .032 |
| 30 | 69.5 | 6.34 | .076 | 78.7 | 17.75 | .028 |
| 50 | 77.3 | 6.64 | .072 | 83.2 | 17.88 | .028 |
| 100 | 83.5 | 6.84 | .07 | 86.5 | 18.43 | .026 |
| 150 | 85.8 | 6.71 | .07 | 87.7 | 18.18 | .026 |
| 200 | 86.8 | 6.74 | .07 | 88.3 | 17.91 | .026 |

Table 1. Continued.

| Distance = 80 wavelengths | | | | | | |
|---------------------------|-------------|-------|----------------|-------------|-------|----------------|
| Frequency (MHz) | Good Earth | | | Poor Earth | | |
| | b (degrees) | p | A ₁ | b (degrees) | p | A ₂ |
| 1 | 5.1 | 1.39 | 0.5 | 9.5 | 6.89 | .109 |
| 5 | 23.9 | 6.38 | .095 | 39.8 | 26.82 | .022 |
| 10 | 41.3 | 10.49 | .056 | 59.1 | 35.85 | .016 |
| 30 | 69.5 | 14.67 | .033 | 78.7 | 41.04 | .014 |
| 50 | 77.3 | 15.35 | .032 | 83.2 | 41.33 | .014 |
| 100 | 83.5 | 15.81 | .031 | 86.5 | 42.62 | .013 |
| 150 | 85.8 | 15.52 | .031 | 87.7 | 42.03 | .013 |
| 200 | 86.8 | 15.59 | .031 | 88.3 | 41.42 | .013 |

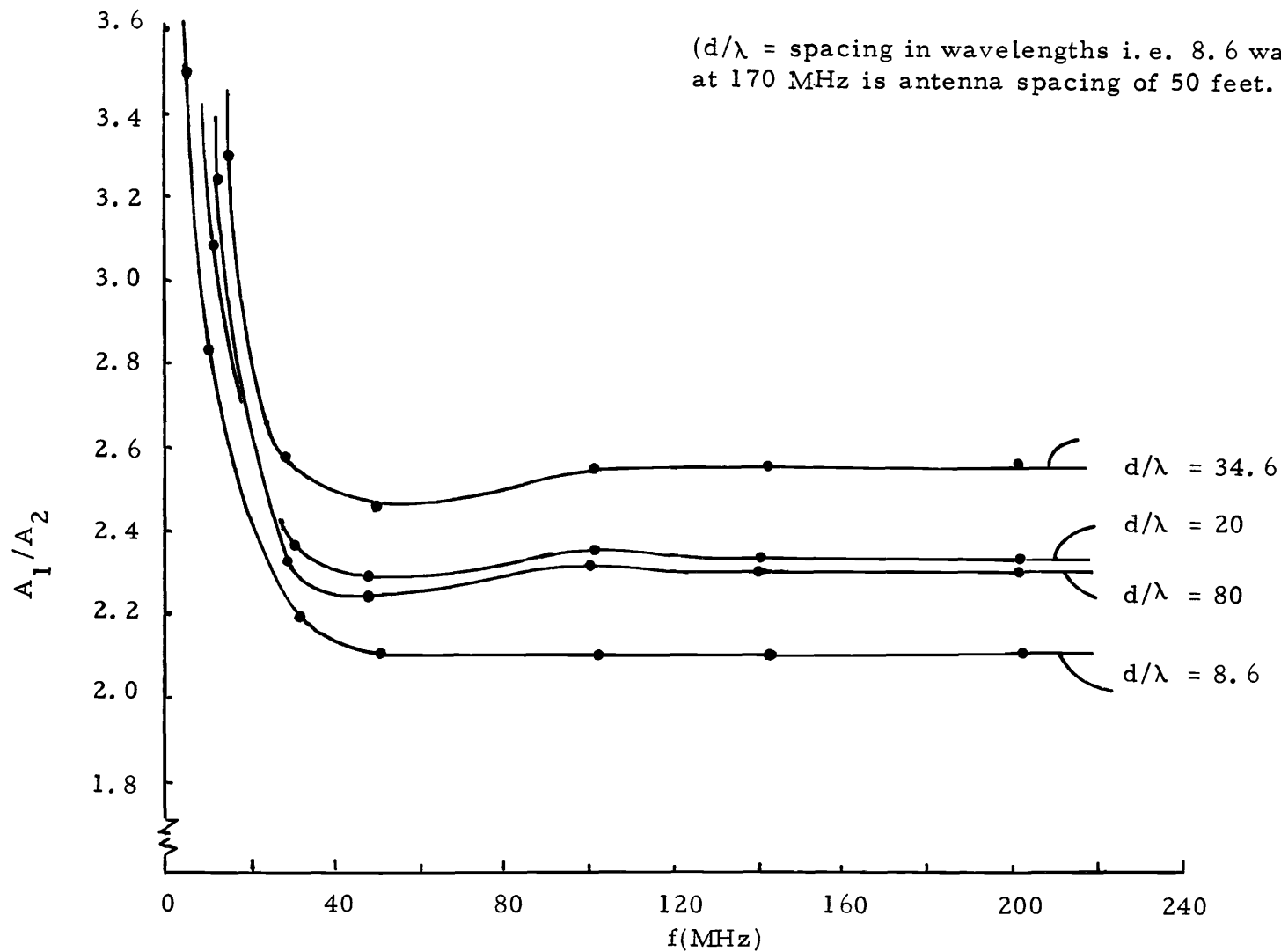

Figure 3. Calculated ratio of field strength for good and poor earth (A_1/A_2) versus frequency (f) for four distances 8.6, 20, 34.6, and 80 wavelengths (d/λ).

was readily obtainable for this frequency and the antenna separation was practical as will be shown in the next section.

Antenna separation

The separation between the transmitting and receiving antennas has a definite effect upon the attenuation factor A and it should be carefully chosen for measuring soil moisture. As the separation becomes smaller, the field strength becomes larger, which is a desired condition in order to simplify instrumentation, but the ratio of wet to dry signals gradually becomes less. An optimum transmitter and receiver antenna separation is the minimum distance that gives a maximum ratio of field strengths measured over good and poor earth.

The effect of separation on the field strength ratio was investigated theoretically. The field strength ratio is given by Equation (12) and the attenuation coefficients A_1 and A_2 are calculated using Equations (2) and (3) and the graph of Figure 1 and the appropriate values for σ and ϵ . Equation (2) shows that the numerical distance p is proportional to the separation in wavelengths and, therefore, the separation essentially determines the position on the curves in Figure 1 which show the relationship between A and p .

The curves in Figure 4 show the relationship between the field strength ratio A_1/A_2 and the separation in wavelengths for three different frequencies, 30, 100, and 200 MHz. From the curves, it is

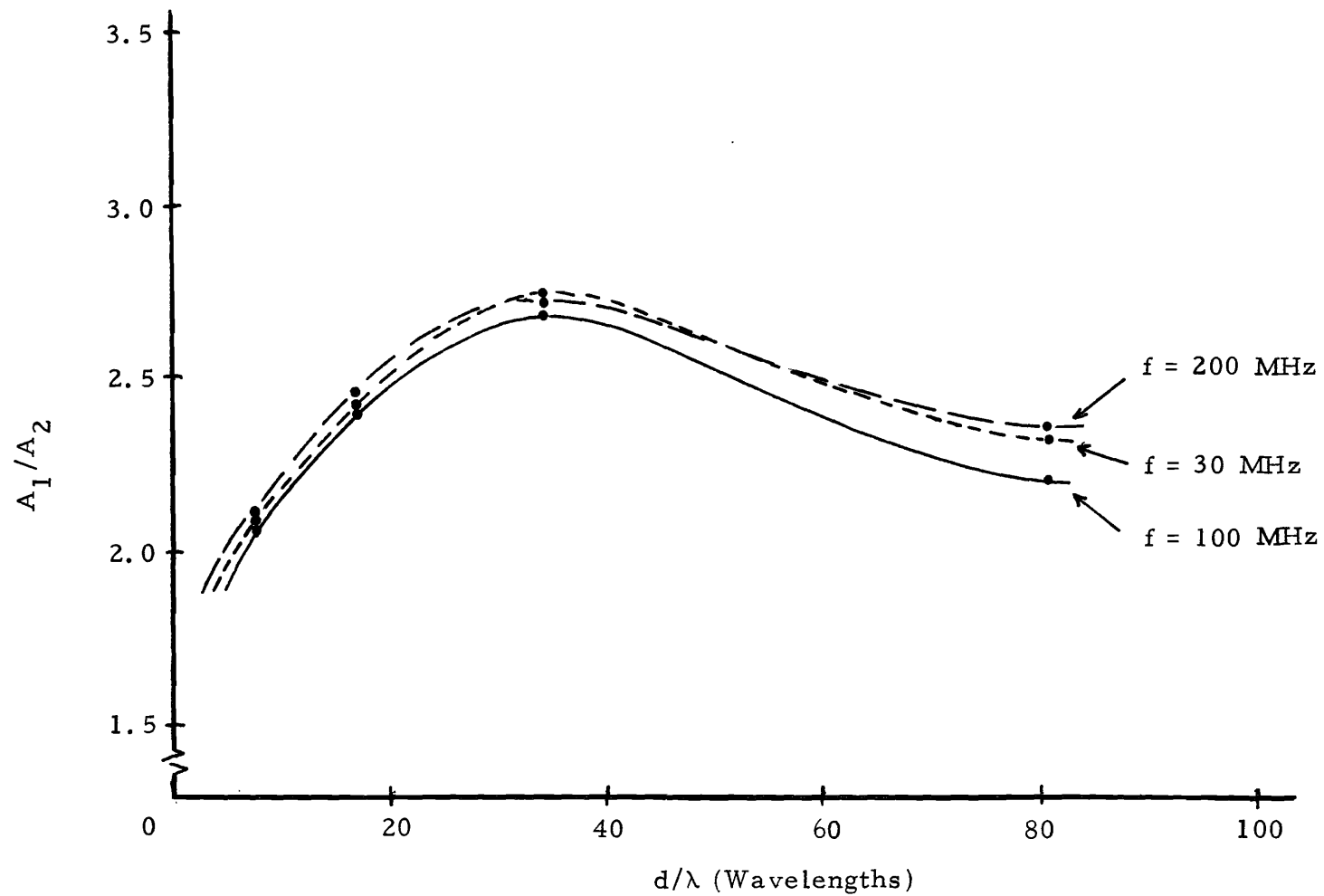

Figure 4. Calculated ratio of field strengths for good and poor earth (A_1/A_2) versus distance (d/λ) for three frequencies, 30, 100, and 200 MHz.

evident that a good field strength ratio is sustained for separations greater than about 8 wavelengths.

Judging from the curve of Figure 4, a separation of 30 wavelengths, or about 175 feet, at 170 MHz will give the maximum wet field to dry field signal ratio. When the desirability of keeping transmitter power low and received signal levels high is taken into account, there is justification to reduce the antenna separation below the so-called optimum. As will be shown later, much of the experimental work was conducted at 50 feet, or 8.6 wavelengths, and 100 feet, 17.3 wavelengths. Adequate wet to dry signal ratios were still maintained for accurate measurements.

Antenna height

The heights of the receiving and transmitting antennas above the ground determine which component of the propagating wave is dominant in producing a given signal at the receiver. According to theory, with vertically polarized waves and earth having reasonably good conductivity, the surface wave ceases to dominate and the space wave becomes more important when the antennas are one or two wavelengths above ground (Terman, 1955). Since near the ground the space wave is independent of earth characteristics, it is desirable to have the surface wave dominate.

The effect of antenna height was investigated with the use of Equation (5) which gives the theoretical field strength of the space

wave. In order to compare the two wave components, an expression for the space wave attenuation coefficient was derived from Equation (5) which could be compared with the surface wave attenuation coefficient given by Equation (1). The relation of comparative signal magnitude is

$$\frac{\text{Space Wave}}{\text{Surface Wave}} = \frac{2 \sin \left(\frac{2\pi h s h r}{\lambda d} \right)}{A} \quad (13)$$

since both the reference field E_0 and the separation d are common to both wave components.

At 170 MHz and a separation of 100 feet, the surface wave attenuation coefficient, which is independent of antenna height, for good earth is .244 and for poor earth is .079. The space wave attenuation coefficient for various antenna heights is given in Table 2.

Table 2. Calculated space wave attenuation coefficient for various antenna heights.

| Height (wavelengths) | Attenuation Coefficient |
|----------------------|-------------------------|
| 0 | 0.0 |
| 1/8 | .0114 |
| 1/4 | .0454 |
| 1 | .726 |

Examination of these figures indicates that the height of the antennas should be in the order of 1/8 wavelength or less for the surface wave to dominate for both poor and good earth.

INSTRUMENTATION

In the search for equipment to conduct the soil moisture tests by use of electromagnetic waves, it became apparent that there was no equipment commercially available that was both economical and convenient to use. Battery operation and ease of portability were considered essential for convenience of field operations; also the field strength meter should have a linear instead of logarithmic scale for added precision in readout. As a result of these requirements, special instruments were designed.

A number of important factors must be considered in making the system design. These factors are itemized as follows:

1. The selection of the radio wave length to use is determined largely by the area of measurement desired. It is also partly determined by the cost; a 10 meter transmitter can be built much more inexpensively than a 2 meter transmitter. Antenna separation should be at least 8 wavelengths. Thus, a 10 meter band antenna would not be used with less than an antenna spacing of

$$10 \text{ meters} \times 3.28 \frac{\text{feet}}{\text{meters}} \times 8 = 262 \text{ feet}^1$$

¹For practical reasons at 10 meter wavelengths the distance used was 300 feet.

For smaller areas, higher frequencies are desirable. At 170 MHz, and a wavelength of 1.76 meters, a minimum separation distance of 50 feet was used between the transmitting and receiving antennas.

2. The system should be battery operated for convenience of field use. Preferably, the battery would operate for one year or longer.
3. Equipment should be readily portable.
4. The accuracy of operation should not be appreciably affected by temperature extremes encountered in the field. Warm-up time from a cold start should not take longer than a few seconds.
5. Operation of both transmitter and receiver should be accomplished by one person. This is probably only practical for minimum antenna separation, i. e., 50-100 feet. For greater distances, two people would be desirable, one to operate the transmitter and one the receiver.

Equipment, meeting the requirements specified for measuring integrated soil moisture, is shown in block diagram form in Figure 5.

The system operates as follows:

1. Two vertical ground plane antennas are placed a given distance apart in the region where soil moisture is to be measured.
2. A radio frequency transmitter is connected to one antenna

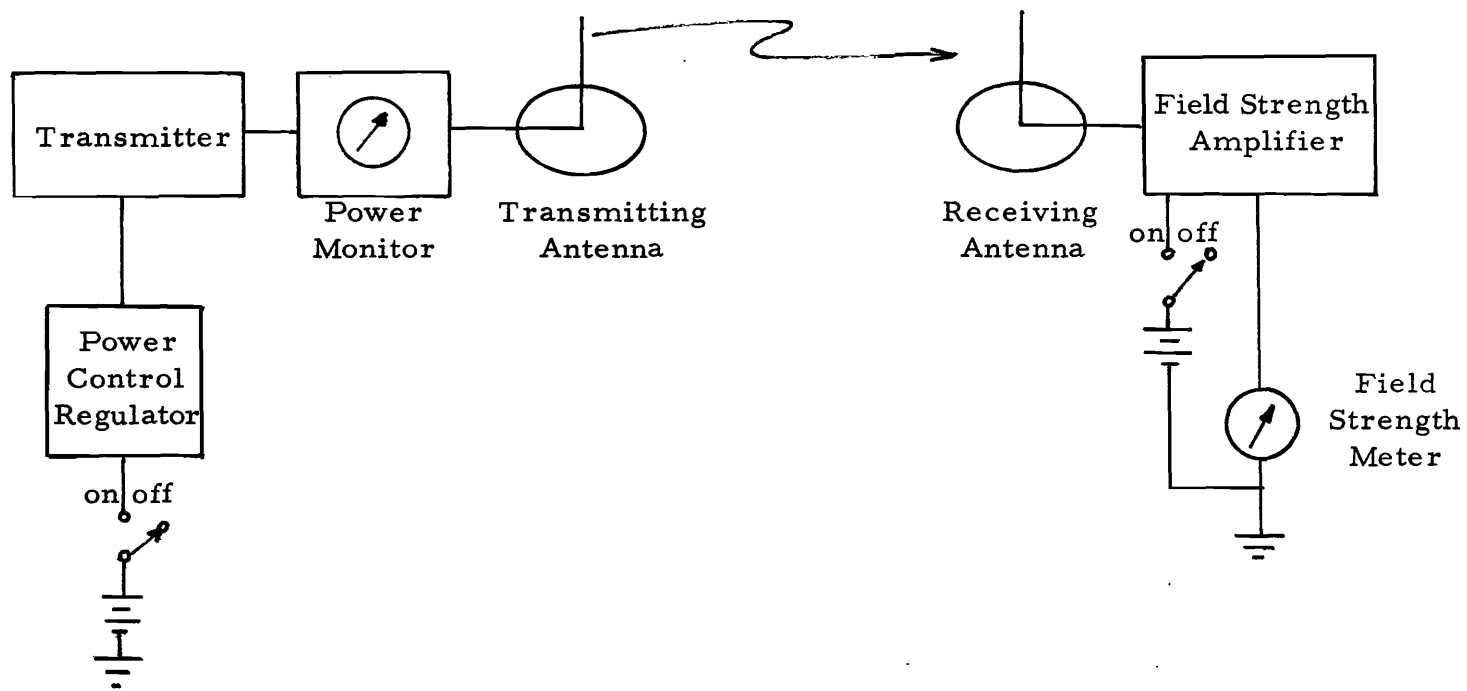

Figure 5. Block diagram of overall soil moisture measuring system configuration.

via a coax cable. A field strength meter is connected via a similar coax cable to the other antenna.

3. A radio frequency cw (continuous carrier) signal of known magnitude is broadcast by the transmitting antenna.
4. A power meter connected to the transmitter is used to monitor and regulate transmitter power to a precise pre-determined value.
5. The received signal strength, as indicated by the field strength meter, is proportional to soil moisture.

Antenna construction

Identical ground plane $\lambda/4$ vertically polarized antennas are used for both transmitting and receiving. The ground plane was chosen because it consists of an artificial ground which is separate from the earth ground. Both the inverted cone type (Figure 6a) and the flat ground plane type (Figure 6b) were used. Virtually no difference between their effectiveness as a radiator and the received signal strength was detected. Consequently, most of the data was ultimately taken using a flat round 3 foot diameter, 24 gage, galvanized-iron sheet as the ground plane.

The cable used was a 50 ohm type RG58 AU coax. Cable length was 50 feet for both the transmitter and receiving antenna. At 170 MHz there is considerable attenuation in the coaxial line amounting to 6 db

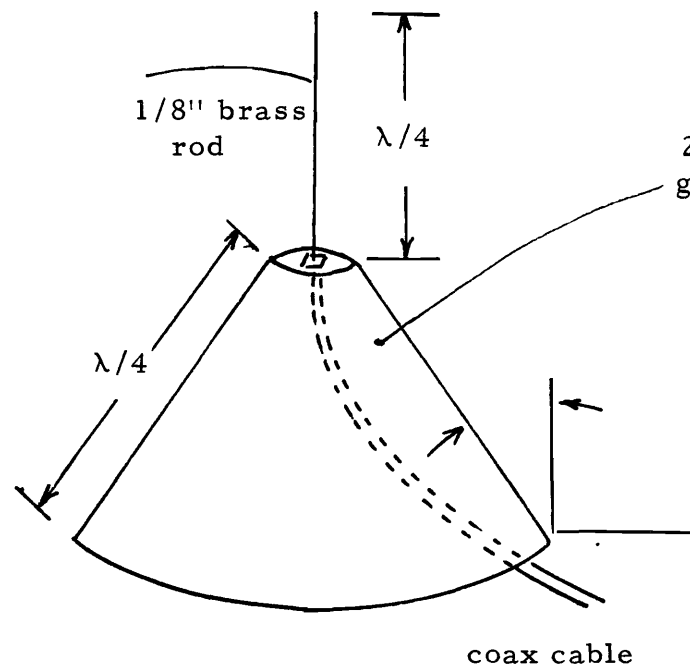

Figure 6a

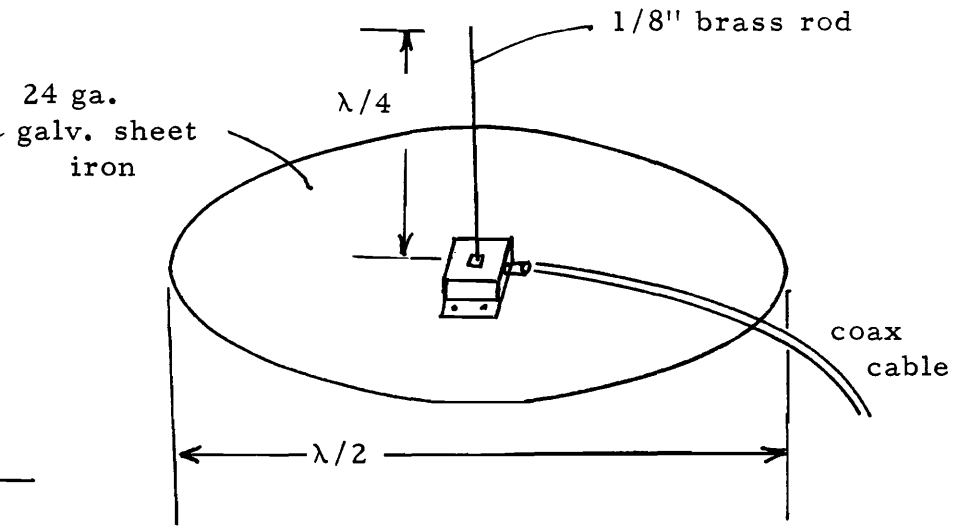

Figure 6b

Figure 6. Two antenna configurations used at 170 MHz. Despite significant differences in antenna electrical impedance and elevation of the antenna above ground, there was no appreciable difference between them, in signal strength observed.

for each cable. This could have been reduced by using shorter and better cable, i. e., RG8 AU.

A 50 foot cable length was chosen for two principal reasons:

(1) With a 50 foot antenna spacing, a 50 foot cable length attached both to the transmitter and the receiver made possible the operation of the complete system with only one person. (See Figure 7.) (2) The operator should be removed a considerable distance from the antenna to avoid unwanted and unpredictable attenuation and reflection caused by an apparent "secondary antenna" in the radiating field, e. g., a person standing too close serves as an antenna.

The rules of good antenna practice were not closely observed in the design of the ground plane for the 10 meter antenna. The same base dimension used for 2 meters was also used for 10 meters. This is a compromise to prevent a large unwieldy ground plane which wouldn't

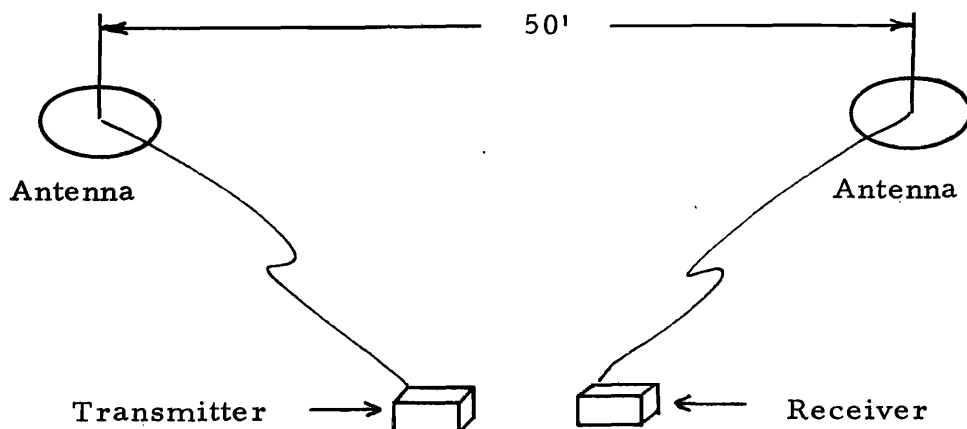

Figure 7. Field arrangement for operation by one operator. Use of 50 foot cables permits transmitter and receiver to be located adjacent to each other but out of line of the transmission path.

be very portable. The design compromise only reduces radiated power which is a constant factor and this factor can be lumped together with other constants in a manner such that it has no detrimental effect.

Transmitter 170 MHz

Before the transmitter and field strength meter could be adequately designed, information had to be obtained regarding the magnitude of the transmitter power output and the associated receiver sensitivity. As these calculations are quite involved but not germane to the understanding of the equipment and its operation, the details are placed in Appendix I of how the equipment was optimally designed with regards to power output and commensurate receiver sensitivity.

Theoretical studies show that any frequency above about 20 MHz and up through the VHF range should work well in determining soil moisture. Since the hydrologic T/M band extends from 170-174 MHz, this was one of the frequency bands selected for the study. At the wavelength corresponding to this frequency, 1.76 meters, the minimum practical test distance is about 50 feet. Much of the test data was acquired using this 50 foot antenna spacing which gave a measured wet-dry signal strength range of about 3 to 1, somewhat more than that calculated using arbitrary values of dielectric strength.

The transmitter used was a commercial, hand-held, 2-watt Sonar transmitter. Any similar transmitter would be satisfactory.

In order to precisely control the output power, maintaining it at some fixed value throughout changing battery conditions and temperatures, a voltage regulator and power output monitor were required. These units are discussed under separate headings. A picture of the 170 MHz transmitter is shown in Figure 8.

Transmitter 27 MHz

Citizen band transmitting equipment operating at 27 MHz is readily available and the cost of a transmitter is nominal, e. g., \$50-\$100. Not only is the transmitter more inexpensive, the wavelength which is about 11 meters long works very well over distances of 300-600 feet or further. Some of the tests were conducted in this frequency band.

Perhaps the chief disadvantage of this frequency is the need for two people to operate the system since the transmitter and receiver are too far separated to be operated conveniently by one person. A picture of the 27 MHz transmitter and VSWR meter is shown in Figure 9; a schematic diagram of the unit used on the project is illustrated in Figure 10.

Voltage regulator

The voltage regulator used for controlling the magnitude of the output power has a controlled variable output. A schematic diagram of this circuit is shown in Figure 11. The 10 K potentiometer shown in



Figure 8. Photograph of 170 MHz transmitter, voltage regulator, and battery box.

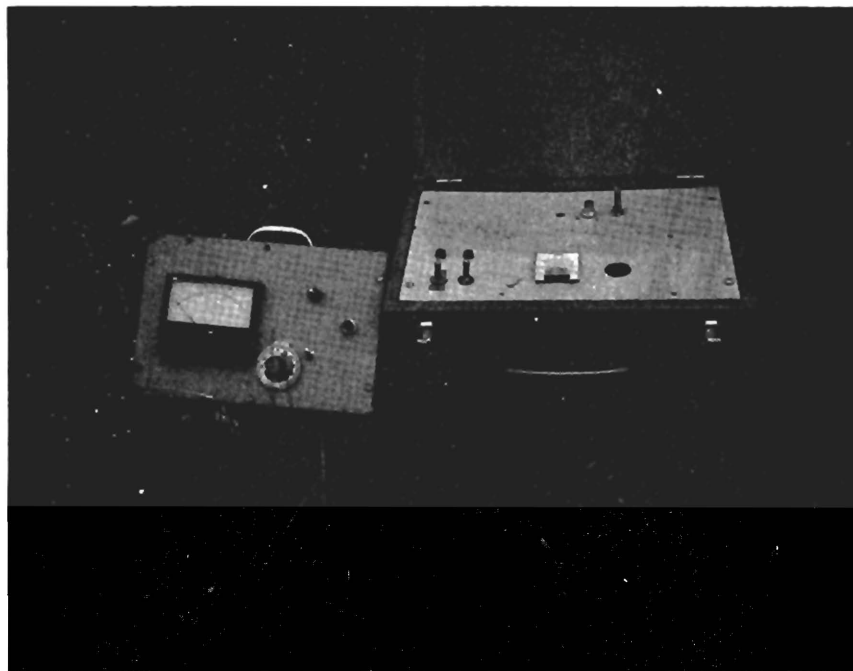
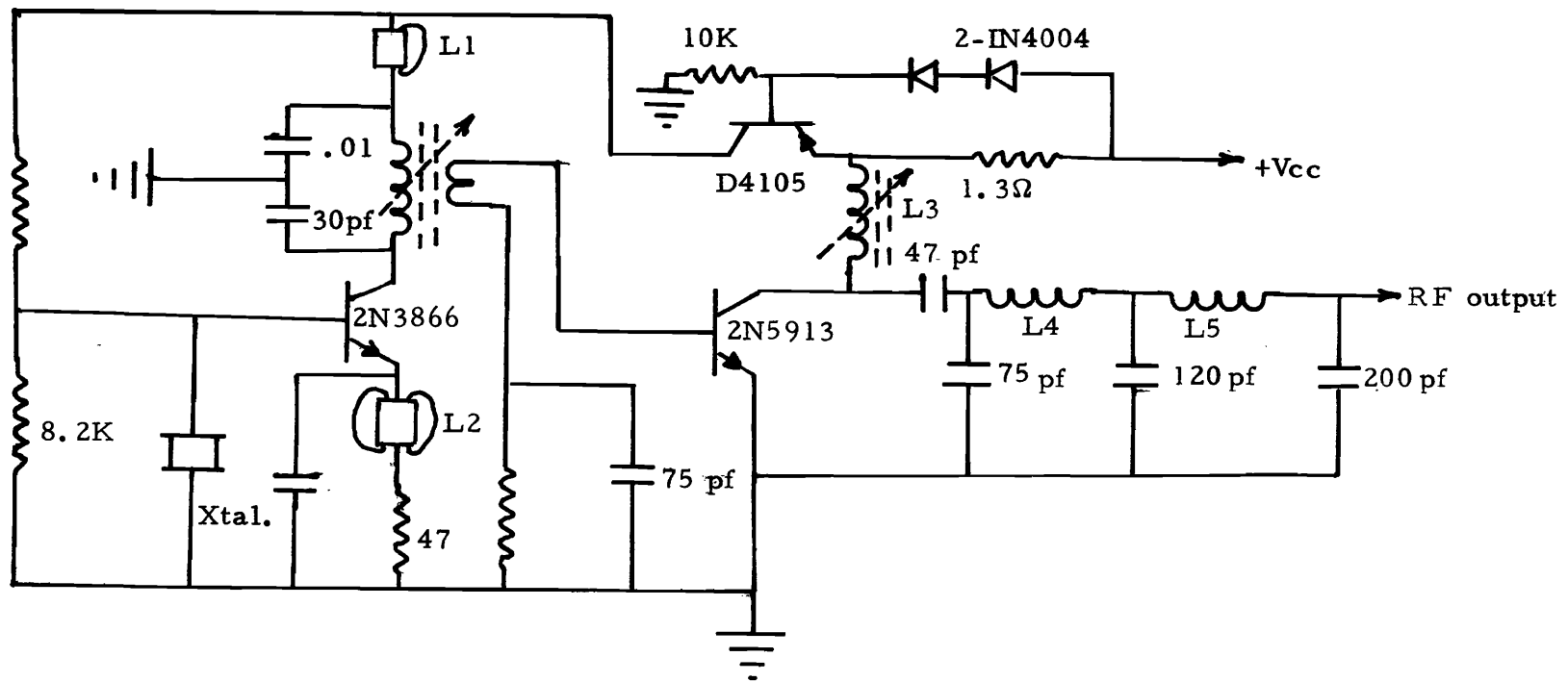

Figure 9. Photograph of 27 MHz transmitter, voltage regulator, power-VSWR meter, and battery box.



Coil forms J. W. Miller 4200

L1 3T 1/8" ferrite bead

L2 3T 1/8" ferrite bead

L3 9 Turns* No. 26 Enameled wire

L4 12 Turns* No. 26 Enameled wire

L5 7 Turns* No. 26 Enameled wire

Xtal. 27.005 MHz

Figure 10. Schematic diagram of a 1 1/2 watt continuous wave 27 MHz transmitter.

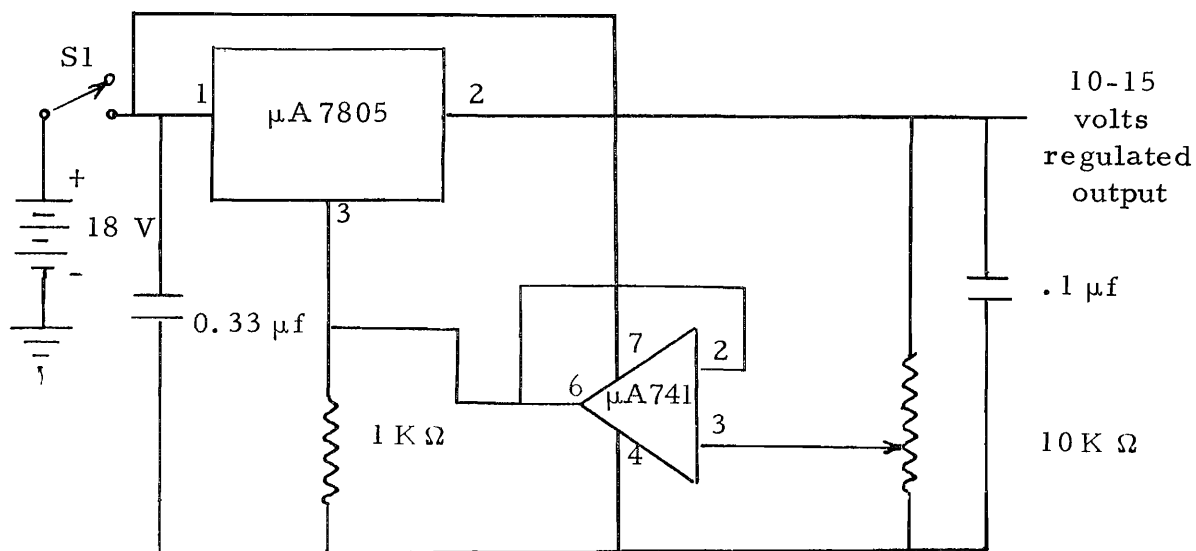

Figure 11. Voltage regulator. Adjustment of the potentiometer adjusts output voltage to obtain the desired transmitter output.

the figure is used to adjust output voltage of the $\mu\text{A}7805$ voltage regulator. Output voltage must be at least 2 volts less than the input voltage for good regulation. Since the transmitters used on the project required about 12-13 volts to obtain a full watt output, an 18 volt battery was used for the primary power source. Thus, about 4 volts of battery sag could be tolerated before the system output dropped below its operational level.

Transmitter power is applied by closing a power-on switch. As field strength measurements require only 2-3 seconds, the on-time of the transmitter takes only long enough to adjust the output power and to obtain the measurement, i.e., 8-10 seconds. Thus, battery power

required is considered to be minimal.

Transmitter power monitor

The monitor used for measuring the transmitter output power and also the standing wave ratio (SWR) is adapted from a circuit published in September 1972 of the publication, QST. Information on this circuit is shown in modified form in Figure 12. As this monitor reading is not absolute, it is calibrated against an r.f. wattmeter. Thereafter, battery voltage is adjusted to obtain the reference value by which all subsequent soil moisture measurements are made.

In addition to making the power adjustments, a figure of merit of antenna match to the transmitter can be made on the monitor. A forward or power-going-out reading is obtained (V_o) and then the reflected power (V_r) is read with the toggle switch in the reverse position. The formula

$$VSWR = \frac{V_o + V_r}{V_o - V_r}$$

gives the voltage standing wave ratio (VSWR) which ideally should be 1.0. In actual operation, due to some mismatch at the antenna the VSWR is about 1.2 which is considered acceptable.

Field strength meter

Theoretical calculations from Appendix I show that the field strength of a one-watt, 170 MHz, transmitter is in the 0-30 millivolt

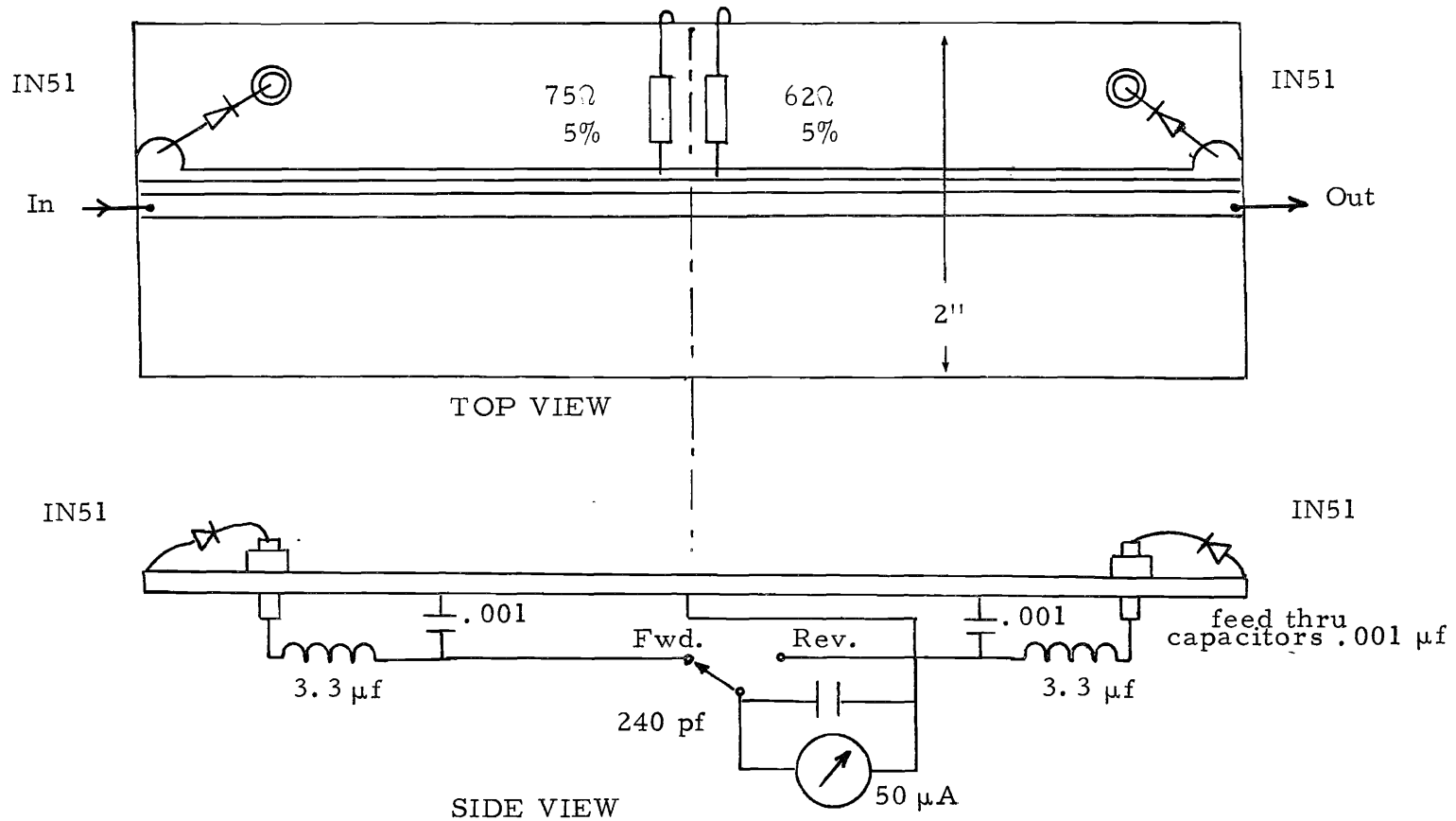

Figure 12. A 170 MHz SWR and relative power meter. Conductors are etched on a glass epoxy board with copper on both sides. Plated underside serves as ground plane. Top side is etched with two conductors one $5/32''$ wide x $6''$ long, the second $3/32''$ wide with a $1/16''$ space between strips. The unit is housed in a $6'' \times 2\ 1/2'' \times 1\ 1/2''$ aluminum box. BNC panel receptacles are used at each end of the box to connect the coax cables.

range, at 50 feet antenna separation, and about the same field strength for a 30 MHz signal at 300 feet antenna separation, the two antenna spacings used most frequently. Developing a suitable instrument for measurement of the field strength was considerably more difficult than first believed. Tuned circuits were troublesome and finally abandoned. Variations in temperature and/or load conditions caused considerable fluctuation in the coil Q and there was the problem of good assurance that the circuit was properly tuned for the frequency being used. There are, of course, commercial field strength meters that cover both of these frequencies; however, they required a 60 cycle power source. No high-resolution, economical, battery-operated, field strength meter was located that was suitable and tuned the desired range. As a result, some design effort was made to make a field strength meter that would be well suited for portable soil moisture field strength measurements. The results of this effort have proved quite satisfactory. The meter has no front end tuning, making it very broad band, yet its sensitivity is adequate. A circuit diagram of the field strength meter is illustrated in Figure 13. The circuit functions as follows:

CW signals picked up by the quarter wave vertical antenna are fed through a 50 ohm coax to an FET gate, Q1, which has a 50 percent on-time that is controlled by the 1000 hz chopper. Thereupon it is fed as r.f. pulses to the detector. This amplifier will detect and amplify

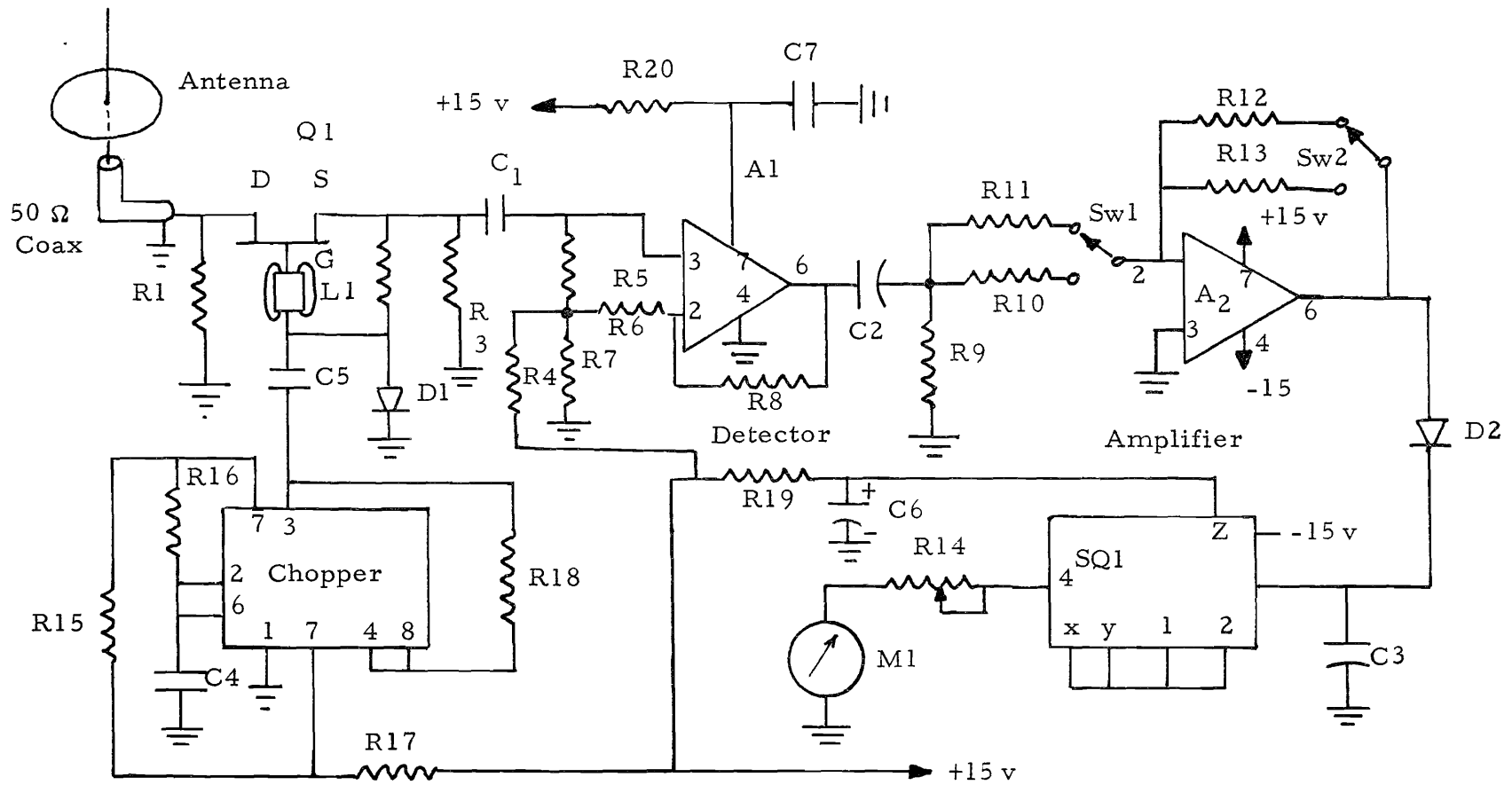

Figure 13. Schematic diagram of field strength meter.

Field Strength Meter Parts List

Resistors

| | |
|------------|-----------------------------------|
| R1 | 47 Ω |
| R2 | 2 M |
| R3, R4 | 4.7 K |
| R5, R6, R7 | 1 K |
| R8 | 220 K |
| R9 | 100 K |
| R10 | 14.5 K nominal value (selected) |
| R11 | 16 K nominal value (selected) |
| R12 | 50 K 1% |
| R13 | 400 K 1% |
| R14 | 10 K (scale adjust potentiometer) |
| R15 | 10 K |
| R16 | 100 K |
| R17 | 3.3 K |
| R18 | 2.2 K |
| R19 | 4.3 Ω |
| R20 | 270 Ω |

Capacitors

| | |
|--------|-------------|
| C1 | 430 pf |
| C2 | 5 μ f |
| C3 | 3 μ f |
| C4 | .03 μ f |
| C5 | .1 μ f |
| C6, C7 | 68 μ f |

Miscellaneous

| | |
|---------|---|
| A1 | 741 (selected) |
| A2 | 741 |
| SQ1 | 4031/25 (Burr-Brown) |
| M1 | 0-15 volt meter |
| L1 | 2 turns #2643022401 ferrite bead from Fair Rite Products Corporation, Wallkill, N. Y. |
| Chopper | NE 555 (National) |
| Q1 | TIS 73 |

the resulting audio signal. The ac signal obtained from the detector is then amplified. There are four gain settings possible by the setting of SW1 and SW2. SW2 adjusts gain for high and low sensitivity, 0-15 mv, and 0-30 mv. Switch SW1 adjusts gain for slight changes in sensitivity at 30 MHz and 170 MHz.

Following the amplifier, the signal is rectified and filtered by capacitor C3 and fed into a square root generator. The square root of the signal is required since square-law detection was obtained in the detector. The output of the square root generator is fed through a variable resistor to an indicating meter. The variable resistor is adjusted to give the desired scale factor on the meter.

Although the system would be slightly more accurate with built-in temperature compensation, since the diodes are temperature sensitive, tests showed these errors are small. Some care was exercised, however, to keep the meter out of direct sunshine when used for extended periods of time.

Power supply

The power supply and accompanying voltage regulators used for the field strength meter are illustrated in Figure 14. The nickel cadmium rechargeable battery powers a free-running multivibrator whose output voltage is stepped up, rectified, filtered, and regulated with both positive and negative voltage regulation, giving plus and minus 15 volt outputs.

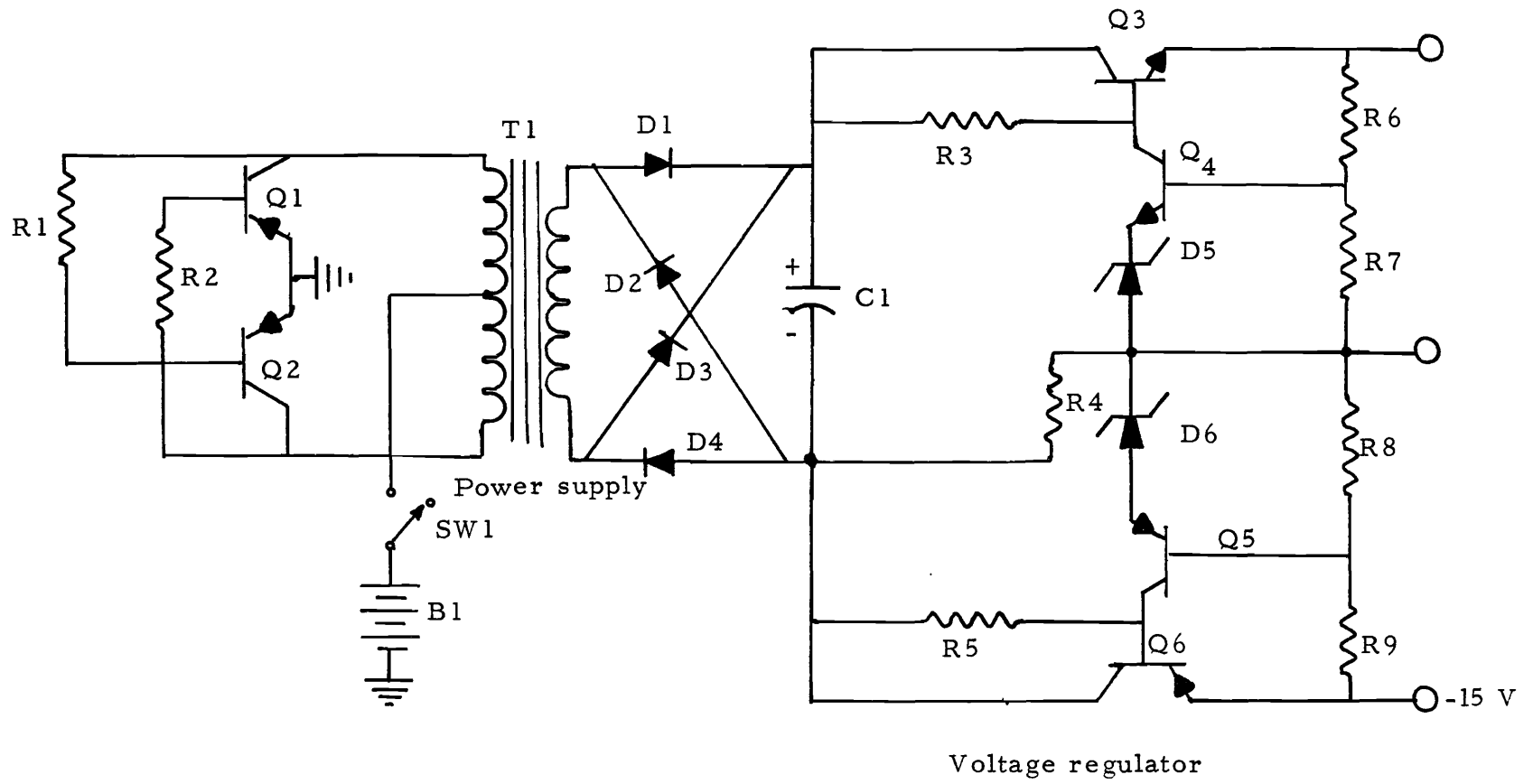

Figure 14. Power supply and voltage regulator circuit for the field strength meter.

Power Supply Parts ListComponents

| | |
|----------------|---------------------------------------|
| R1, R2 | 910 Ω $\frac{1}{4}$ W \pm 5% |
| R3, R5 | 2.2 K |
| R4 | 1.8 K |
| R6 | \approx 4.2 K (selected) |
| R7, R8 | 2.7 K |
| R9 | 4.7 K |
| C1 | 150 μ f, 50 V DC |
| T1 | 1:4.5 step up w/ct |
| Q1, Q2 | 2N2139 |
| Q3 | 2N5496 |
| Q4 | 2N5189 |
| Q5, Q6 | 2N1174 |
| B1 | 7.5 volt battery #560 Eveready |
| SW1 | Power-on switch |
| D1, D2, D3, D4 | KBP005 Bridge rectifier |
| D5, D6 | 5.8 V Ref Zener |

Capacity of the battery and load drain are such that several months of moderate use can be obtained before a battery recharge is necessary.

EXPERIMENTAL RESULTS

Although theoretical analysis predicts that soil moisture can be readily determined by the outlined method presented in this report, chief interest lies in the question, "How well do field tests corroborate with theory and does it work sufficiently well to be useful?" Experimental field data are presented for further system evaluation in answer to these questions.

Before proceeding with these details, comment should be made regarding some of the practical aspects of field tests. In order to evaluate variables, it is advantageous to hold all the variables but one constant while it is varied to determine its effect on the system. Thereupon, the second variable is allowed to vary, holding others constant while its effect is determined, then the third variable is permitted to vary, etc. When dealing with the capriciousness of nature, it is not possible to conduct such ideal tests. For example, September was one of the wetter months of record for Cache Valley as shown in Table 3. Any experiment planned that month would be accordingly disturbed. For a soil moisture depletion rate test, ideally the soil should be initially wet and then be allowed to gradually dry out, without the sporadic application of uncertain amounts of precipitation. As soil loses moisture slowly, this test could last an entire summer. With

Table 3. Record of precipitation in Cache Valley by months for long term average and for 1973.

| | June | July | Aug. | Sept. |
|---------|-------|-------|-------|-------|
| 1973 | 1.45" | 1.40" | 1.07" | 4.93" |
| Average | 1.76 | 0.34 | 0.87 | 0.94 |

sporadic rainfall however some of the same soil moisture conditions may be repeated several times while the end value of extremely dry soil conditions may not be reached. It is generally possible however to observe soil moisture variations ranging between saturation and the wilting point which is the primary range of interest.

Area of effect

One of the initial goals of the experimental measurement was to determine the surface area of effect. Two experimental tests were conducted using 170 MHz antennas; one test with 100 foot antenna separation, the other test with a 50 foot separation. In each test the antennas were moved laterally from the center of the wet field to the adjacent dry area as shown in Figure 15. The field strength as a function of antenna position is plotted in each case and the results are shown in Figures 16 and 17. In each of these tests the wet area was obtained by pumping 1000 - 2000 gallons of water onto the test site.

Using the data of Figure 17, they are plotted in Figure 20 and compared in that figure to theoretical calculation. The theoretical

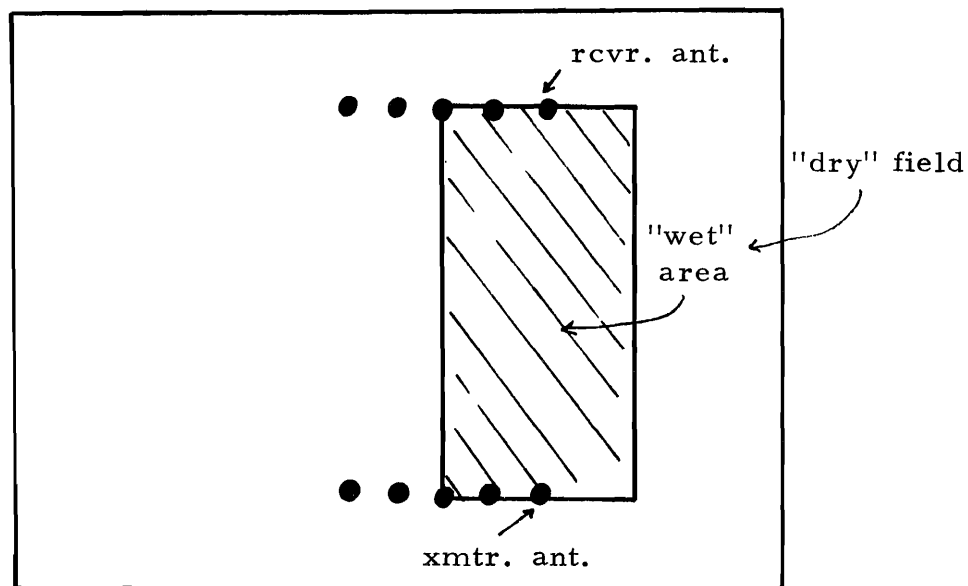

Figure 15. Plan view of a wet field section located in the middle of a "dry" field. Dots represent antenna placement position for area of influence tests.

calculations are based on the assumption that the effective width is 25 feet for an antenna separation of 50 feet. As can be seen, there is fairly close agreement between the theoretical and actual values measured suggesting that the area of influence was approximately equivalent to the values chosen. A slight departure from the theoretical value at the 1/4 wet/dry ratio demonstrates that in actuality the fringes of the 25 foot wide strip are not as important in affecting the field strength as is the more nearly direct-line-of-sight. In actuality, the field-of-effect region is more nearly oval shaped rather than rectangularly shaped. As the area of effect is not delineated by a sharp demarcation but a "grey" area, it is difficult to depict the exact boundaries. Tests

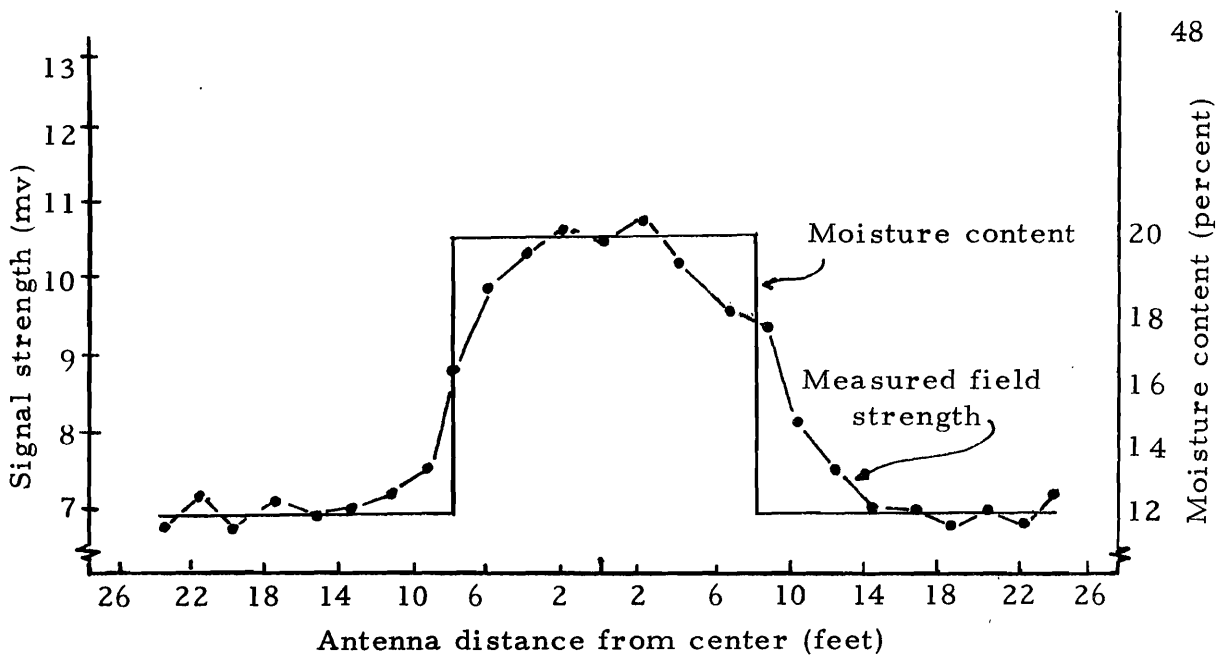

Figure 16. A plot of field strength versus antenna placement with respect to a wet strip of ground 16' wide x 100' long.

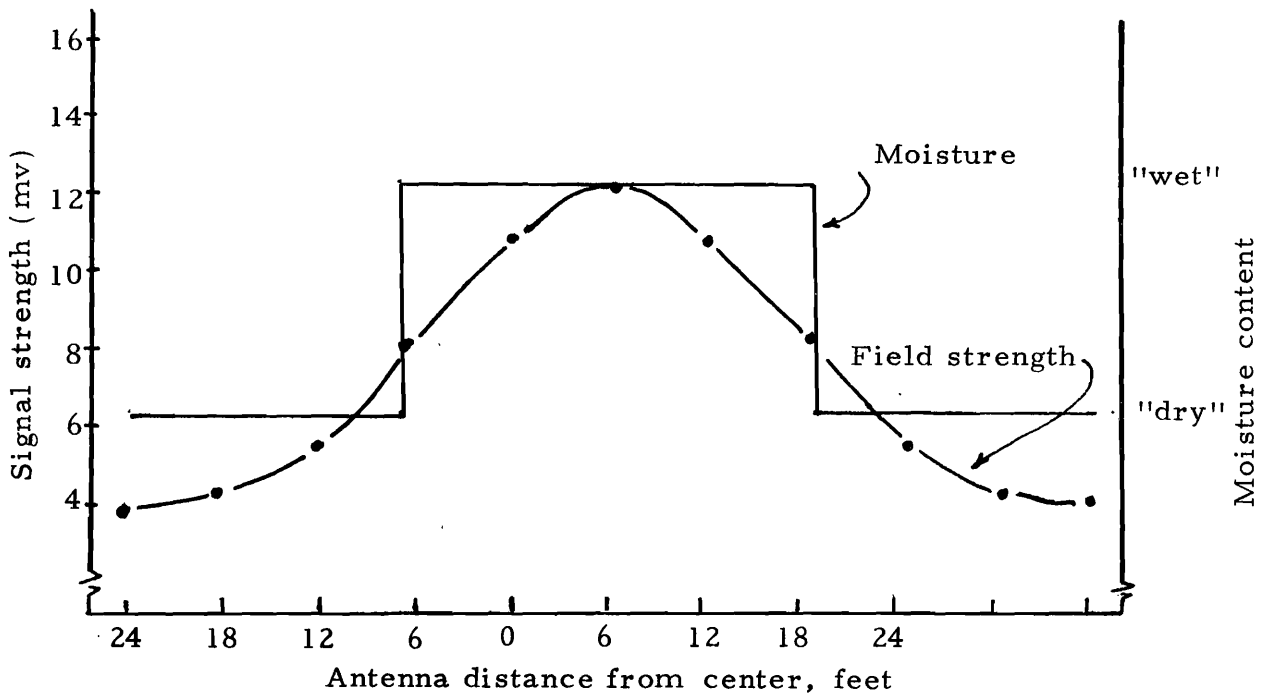

Figure 17. A plot of field strength versus antenna placement with respect to a wet strip of ground 25' wide x 50' long. The "wet" area had 1.6" of water applied the previous day.

show, however, that the approximate rectangular area of Figure 20 correlates with experimental results with some improvement possible if the area is oval or football shaped having a length to maximum width ratio of about 2 to 1.

In retrospect, when conducting the area of effect tests, the wet area test bed should have been considerably wider than the estimated beam width of 25 feet. This would remove wet-dry boundary regions away from the test area and eliminate possible reflections at the boundary that could conceivably give incorrect results. The good correlation between calculated and measured wet-dry effects obtained in Figure 18, however, tends to support the fact that effective beam width is about as indicated. The wet area of Figure 16 is known to be too narrow to effectively determine beam width since the wet to dry signal ratio is about 1.5 to 1 while that of Figure 17 is more representative of wet to dry signal ratios of 2.8 to 1.

Soil dielectrics (capacitor analogy evaluation)

From theoretical discussions presented earlier, the soil is expected to behave as a dielectric. If this is the situation, then selectively wetting a portion of the ground as shown in Figure 19 will permit an analysis based on the "two series-capacitors analogy."

If two capacitors of equal physical size are connected in series, but have different dielectric constants, then their total series capacity can be expressed as

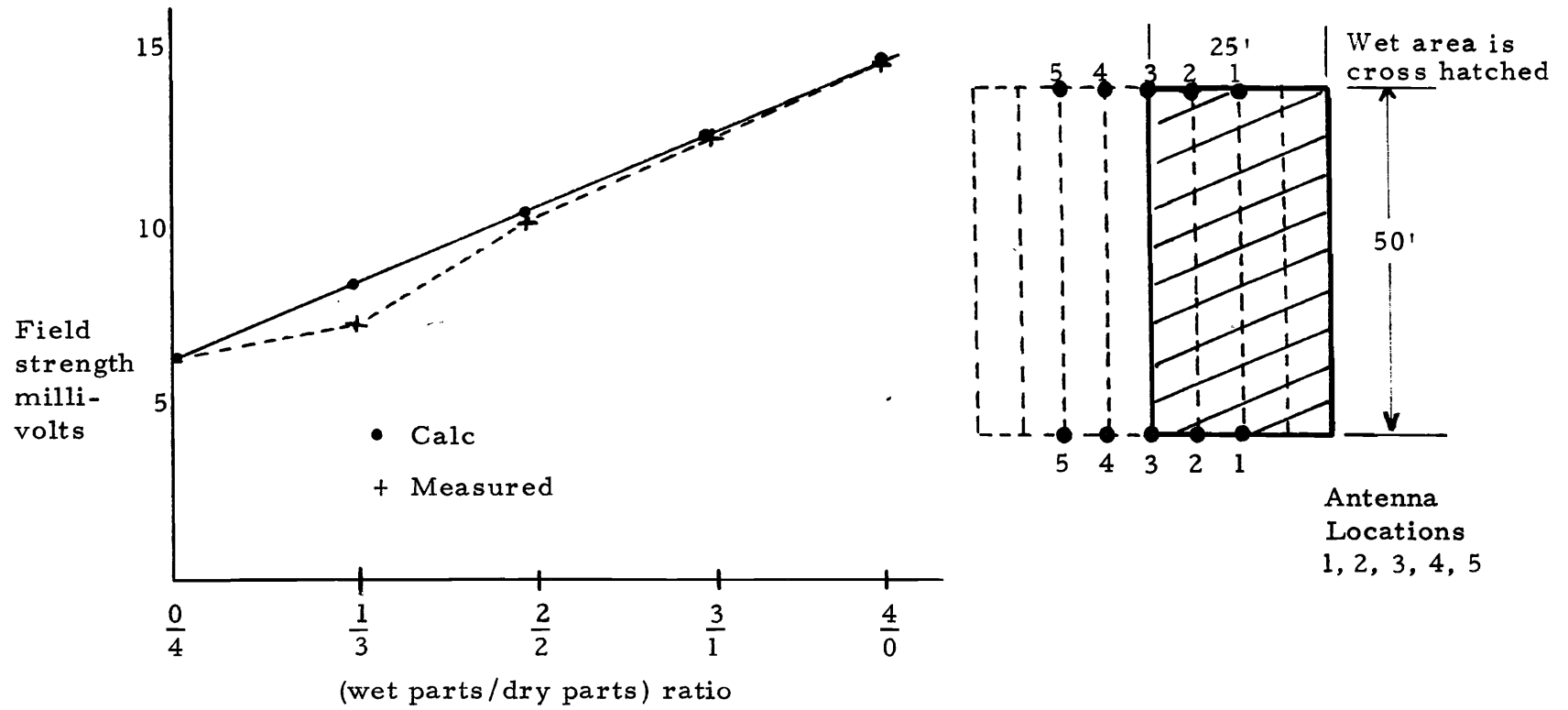

Figure 18. Plot and comparison of field strength between varying degrees of wet versus dry soil. The theoretical field strength calculation is based on the assumption that the effective measurement area is 25' wide by 50' long. As the antenna is moved from position 1, the all-wet area, to position 2, the 3/4 wet, 1/4 dry area, etc. to position 5, the all-dry area, the field strength is measured and calculated for each position.

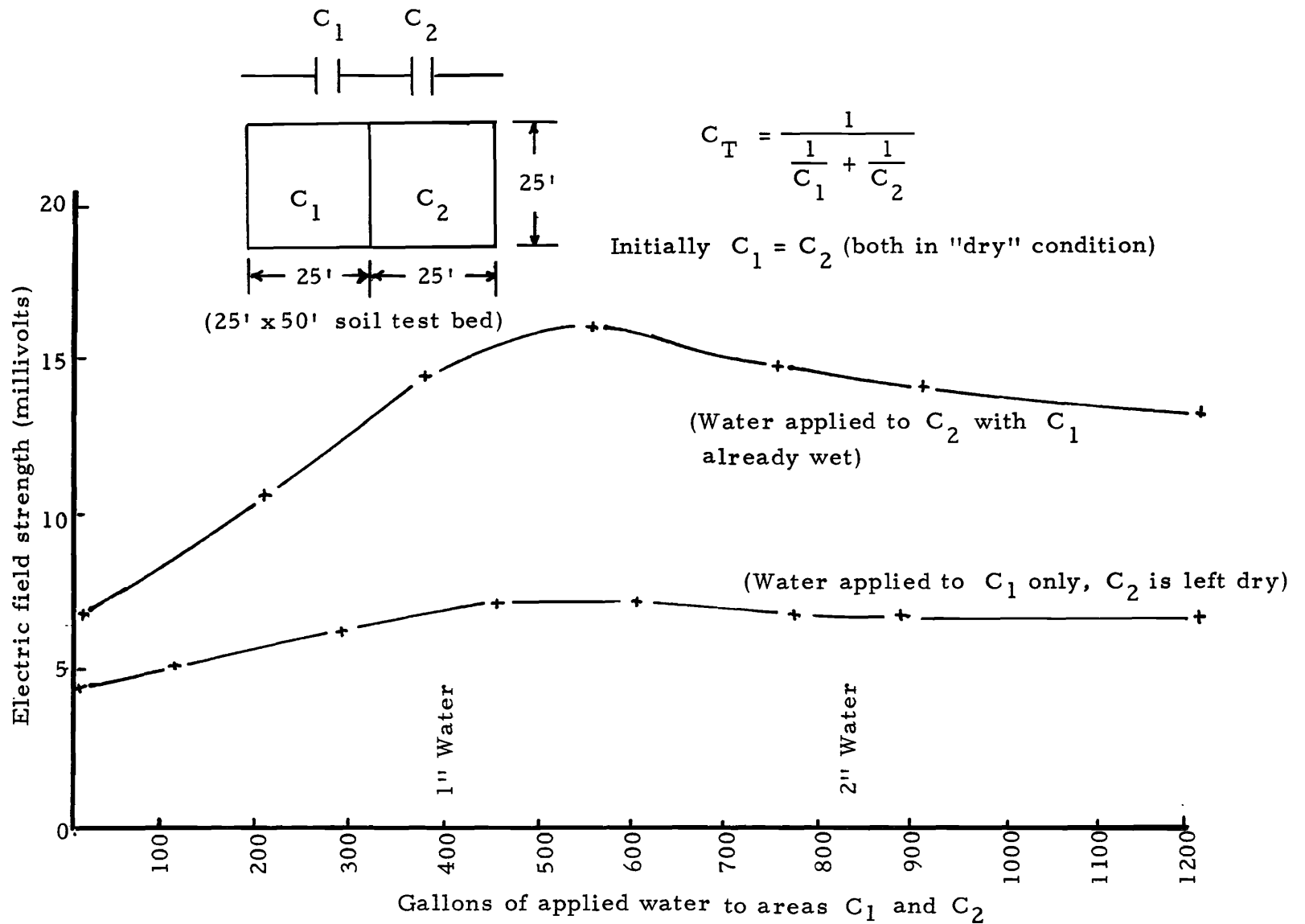

Figure 19. Empirical determination that the received field strength is analogous to the soil dielectric. Using the initial dry soil field strength of 4.4 mv and wet soil value of 14 mv, the half-wet field, half-dry field situation should give 6.7 mv; calculated, it measured 6.8 mv. This tends to verify the capacitors theory analogy.

$$C_T = \frac{1}{\frac{1}{C_1} + \frac{1}{C_2}} \quad (14)$$

In an actual field test, a 25 ft x 50 ft area was used as a test bed. In its "dry" state, the field strength was 4.4 mv. When one-half of the area, 25 ft x 25 ft, was wetted, the received signal strength was 6.8 mv. With it all wet, the signal rose to 14 mv. These values have an analog to the dielectric constants, since field strength should be proportional to capacity which is directly proportional to the dielectric constant and inversely proportional to the thickness of the dielectric. Hence, corresponding millivolt levels can be inserted in the capacitance equation giving, for the half-wet half-dry condition

$$\text{Field Strength} \sim C_T \sim \frac{1}{\frac{1}{28 \text{ mv}} + \frac{1}{8.8 \text{ mv}}} = 6.7 \text{ mv} \quad (15)$$

The measured value for this condition is 6.8 mv compared to 6.7 mv calculated, which is considered to be very good agreement. Note that values for C_1 and C_2 are two times as large as measured, i. e., 14 and 4.4 mv. This is due to the fact that capacitance is inversely proportional to the thickness of the dielectric. Therefore, a 25 foot length is given a value of 2 times the capacitance over that of a 50 foot length.

An observation can be made at this point regarding the so-called "integrated" or averaged measurement of soil moisture. When dry

and wet regions are running parallel to the path between the transmitting and receiving antennas in either the horizontal or vertical plane, the observed measured value is the average of the two regions. If a long narrow dry section of ground, i. e., gravel or sand bar, exists perpendicular to the path of transmission, received field strength representing the average value of soil moisture will not be obtained, since the dry section will dominate the reading, as illustrated by the insertion in Equation (14), of large and small numbers representing wet and dry regions, respectively.

Radio wave field strength versus applied water

One of the most direct approaches to observing effects soil moisture has on the field strength is to apply known amounts of water to a test bed and record the corresponding field strength. Figure 20 illustrates the results from this type of an experiment. The soil moisture was initially 6 percent by weight at the beginning of the test. Water was applied via sprinkling; the area sprinkled measured 25 ft x 50 ft square. The transmitter frequency was 170.225 MHz at a power of one watt into a 50 foot RG58 cable to a $\lambda/4$ ground-plane antenna. The field strength was observed to be linear with applied water until 0.64 inch of water was applied, thereupon a nonlinear increase in field strength was observed until 1.6 inches of water was applied at which point

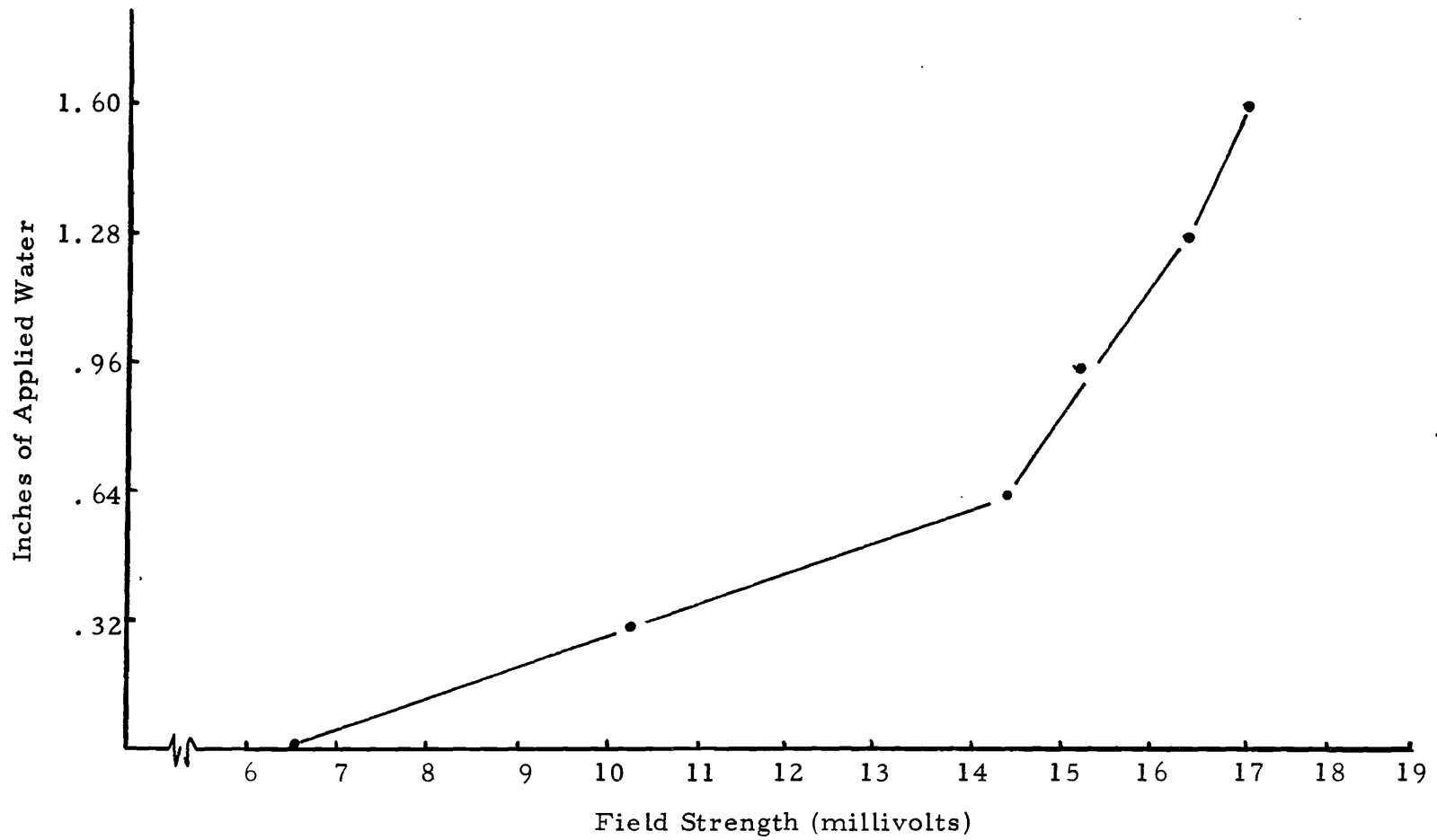

Figure 20. Plot of field strength versus inches of water applied over a 5 hour period.

the test was terminated. The water was applied at a rate of .32 inch per hour. Virtually all of the water infiltrated as there was no runoff or appreciable collection of water on the surface. The following day the field strength had "sagged" back to 14 millivolts. The second day after the test the reading was 13.4 millivolts at which point an additional .4 inch of water was applied increasing the field strength to 14.6 mv and 1/2 hour later it was 14.4 mv. Seven days following the initial test the field strength was 11.6 mv. Grass vegetation growing on the plot was relatively dormant during this period (July). The loss of signal with time was considered to be due to evaporation losses at the surface and drainage of water downward. As water goes deeper, its ability to enhance the radio signal diminishes. This phenomenon was discussed under the topic on depth of penetration.

Test site data

Semiarid range land shown in the photograph of Figure 21 was selected as a test site for monitoring of natural soil moisture conditions. Annual precipitation at the Green Canyon site averages about 15 inches per year. Vegetation is principally composed of western wheat grass, yarrow, orchard grass, chicory, rabbit brush, and sage brush.

The top soil is about 12 to 14 inches deep. Under the top soil is a gravel-clay mixture which made difficult the obtaining of soil samples



Figure 21. Range land showing typical vegetation growth and 170 MHz antenna used in tests.

below about one and one-half feet. The top soil is classified as Greenville, gravely sandy loam. Soil moisture data taken by gravimetric measurements and also by field strength methods were obtained during several month-long periods spanning 24 months and the soil moisture as determined by weight maintained a constant relationship with the magnitude of the attenuated radio wave. For the data shown, the soil moisture was averaged over a two foot depth. A plot of this relationship is illustrated in Figure 22.

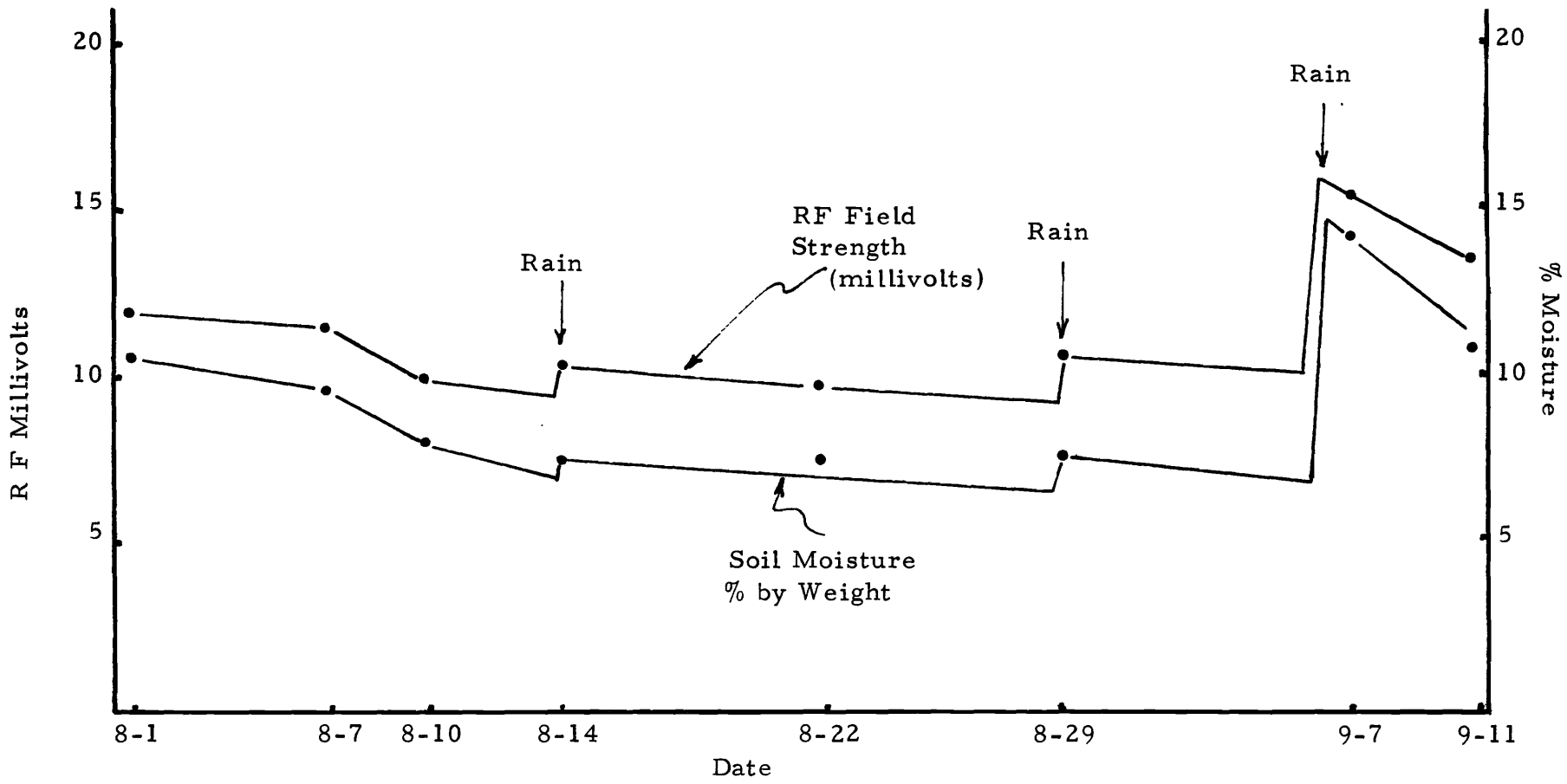

Figure 22. Green Canyon-North, range land with sparse vegetation. (Radio field strength versus soil moisture as a function of time.)

A linearity test can be conducted on field strength data shown in Figure 22 to determine if a linear relationship exists between the field strength and soil moisture. To test for linearity the data can be plotted using the equation for a straight line

$$y = mx + b$$

in which

x is percent of soil

y is the field strength in millivolts

b is the value of the field strength when the soil moisture is zero

m is the slope as constant of proportionality

The results of the data plotted in this manner are illustrated in Figure 23. In the data thus presented there appears to be an almost perfect one-to-one relationship between the two methods used in measuring soil moisture, radio wave versus gravity method. No values were observed at the extremities of the soil moisture range during this test but based on other data such as that of Figure 20, it is expected to behave as indicated by the dashed line extensions.

Numerous other tests, similar to the one just described, were conducted at different sites. Typical results for these tests are illustrated in Figures 24 and 25. Straight line plots of field strength (F/S) versus soil moisture are plotted in Figures 26 and 27 and correspond to

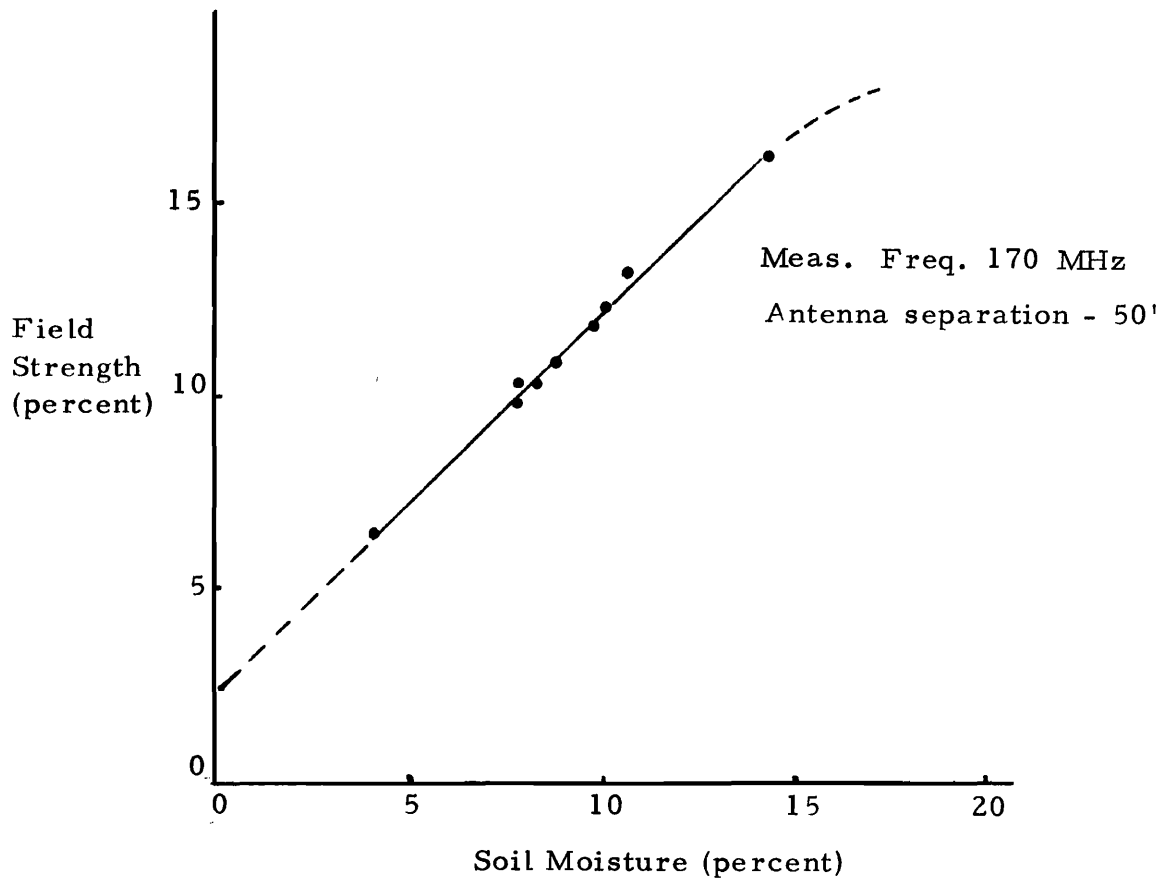

Figure 23. Green Canyon-North plot of soil moisture by gravity measurement versus electrical field strength.

Figures 24 and 25 respectively. The data shown in these figures illustrate a generally good correlation, particularly so in Figure 26 when the soil was loose and soil samples were easily obtained.

In general it is felt that much of the scatter is due to the standard used for calibration. Generally two or three soil samples were taken and averaged for the determination of soil moisture. Individual variations

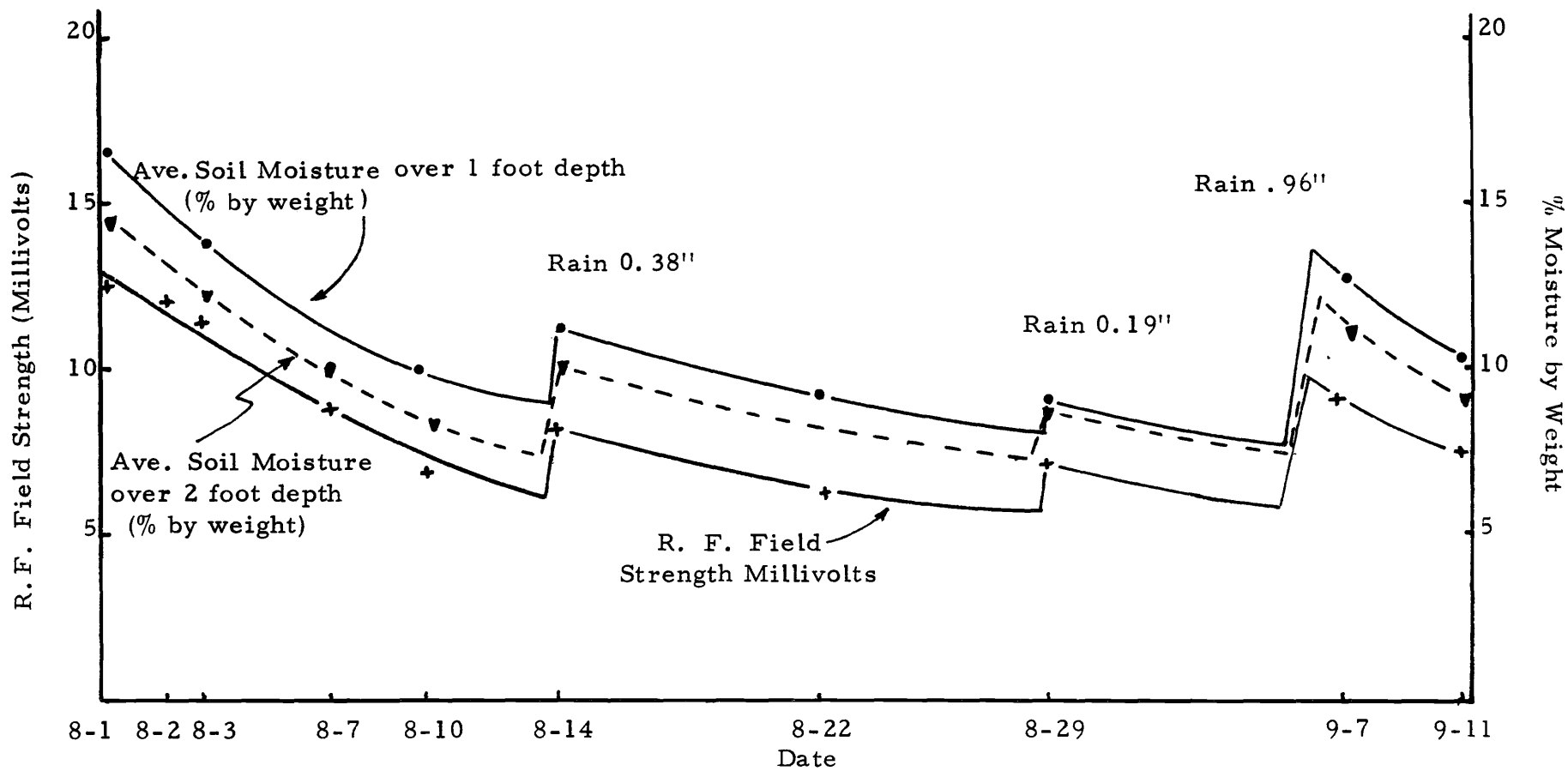

Figure 24. Comparison of soil moisture (% by weight) and R. F. field strength. Data taken at an Agriculture Experiment farm on fallow ground. (Aug. - Sept. 1972).

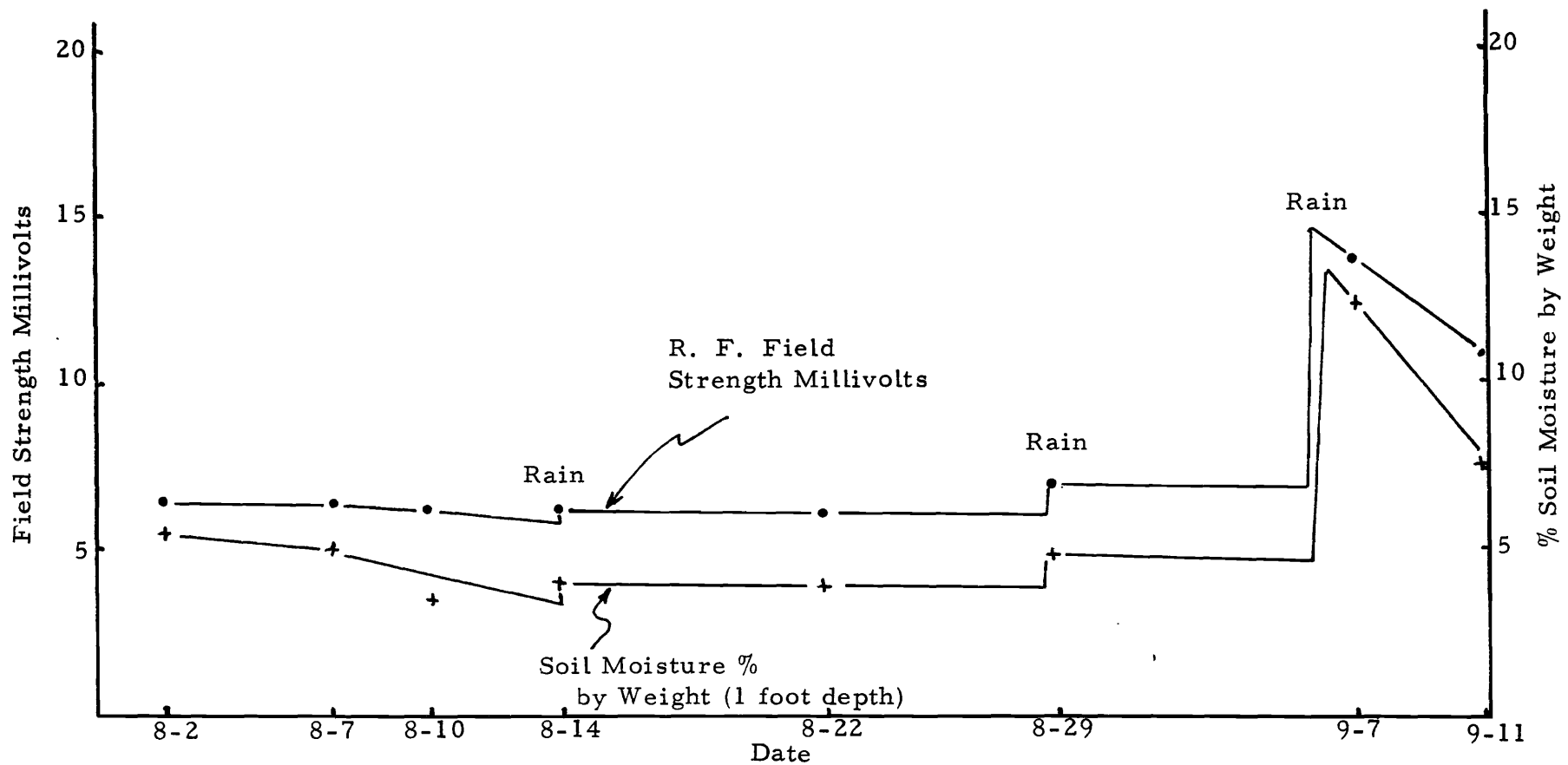

Figure 25. Green Canyon-South, range land with sparse vegetation. (Radio field strength versus soil moisture as a function of time.)

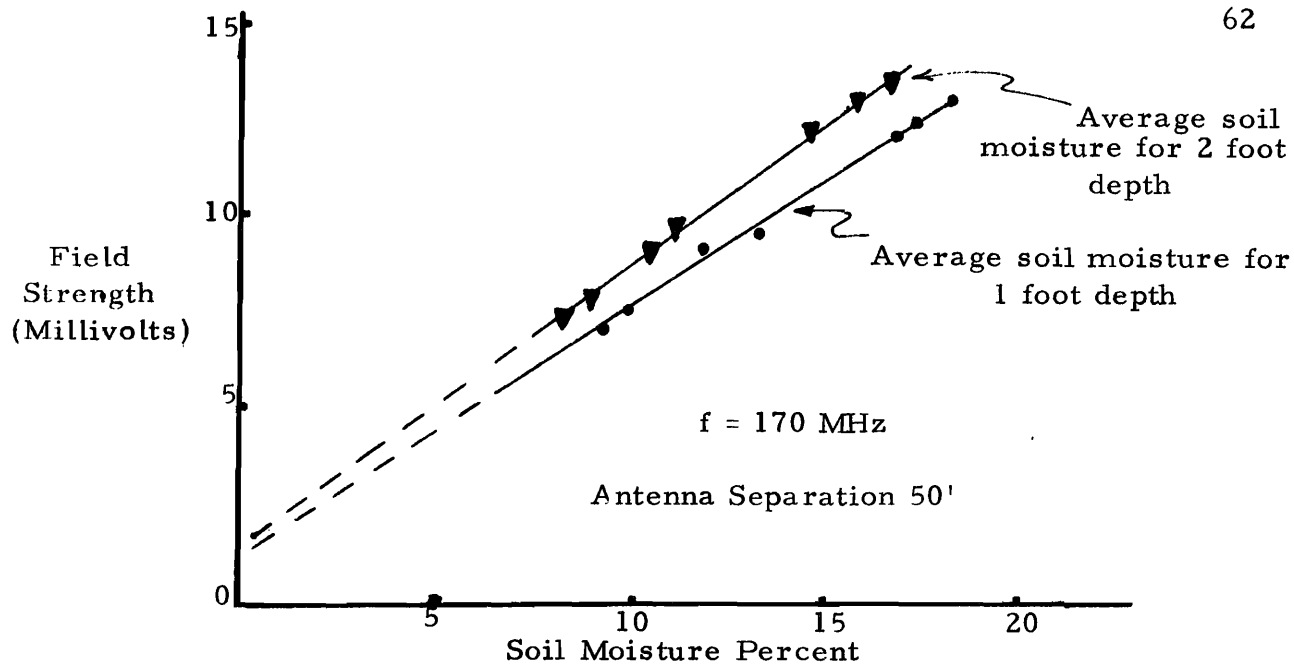

Figure 26. Grass plot on agriculture experiment farm. Soil is Millville silt loam.

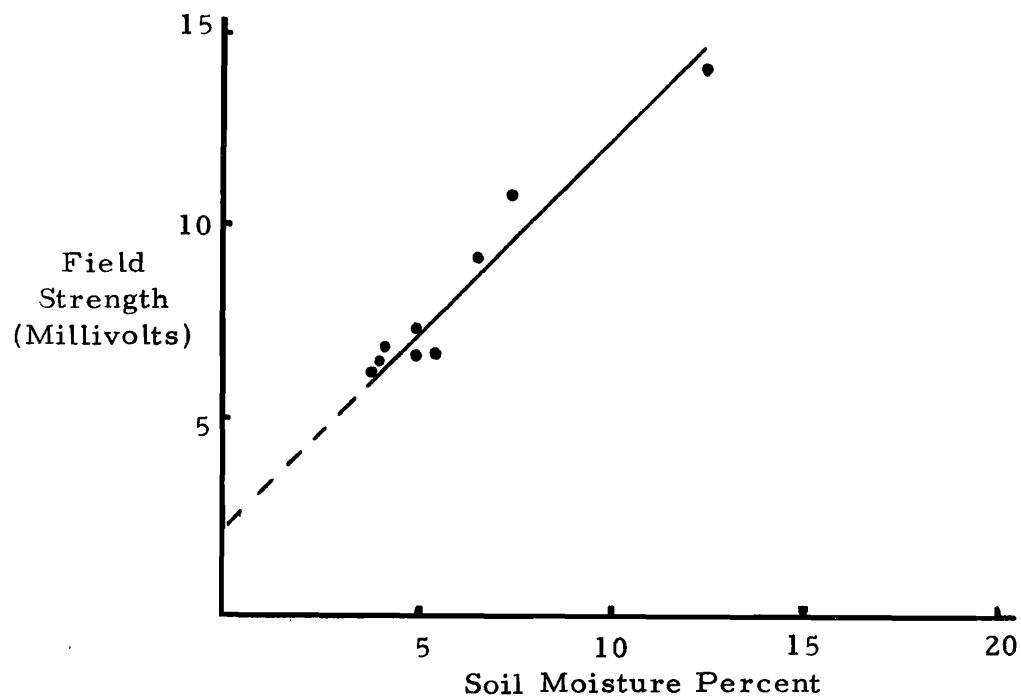

Figure 27. Green Canyon-South rangeland with grass and brush vegetation.

between samples were observed to be of sufficient magnitude to account for much if not all of the scatter observed in the data points. For a more accurate standard, probably 7 or more soil samples should have been averaged together. Such a technique would aid materially in getting more accurate results. The data of Figure 28 probably illustrate the point being discussed. Considerable scatter in this figure was attributed to too few soil samples. The test was conducted in a rough plowed ground area. Due to the hills and valleys shaded and sunny spots, considerable fluctuation apparently existed in soil samples being taken. Another factor was that samples were taken on a weight, in lieu of a volume, basis which may be aggravated by the plowed field; hence the scatter noted in the figure.

Another interesting area that was studied was an apple orchard. The data were taken during the early part of the growing season before irrigation commenced, April 24 through May 15. During this period, the orchard grass grew to a height of about 9 inches. The antennas were situated parallel to the rows and equidistant between the rows. Antenna spacing was 50 feet and transmission frequency was 170 MHz. Measurement of soil moisture in the orchard presented some unique problems. Tree spacing was such that the water depletion was not uniform. It is difficult to get representative soil moisture samples under these circumstances. Soil moisture was observed to vary greatly from the center line between tree rows, to areas adjacent to the tree trunk where the irrigation ditches ran.

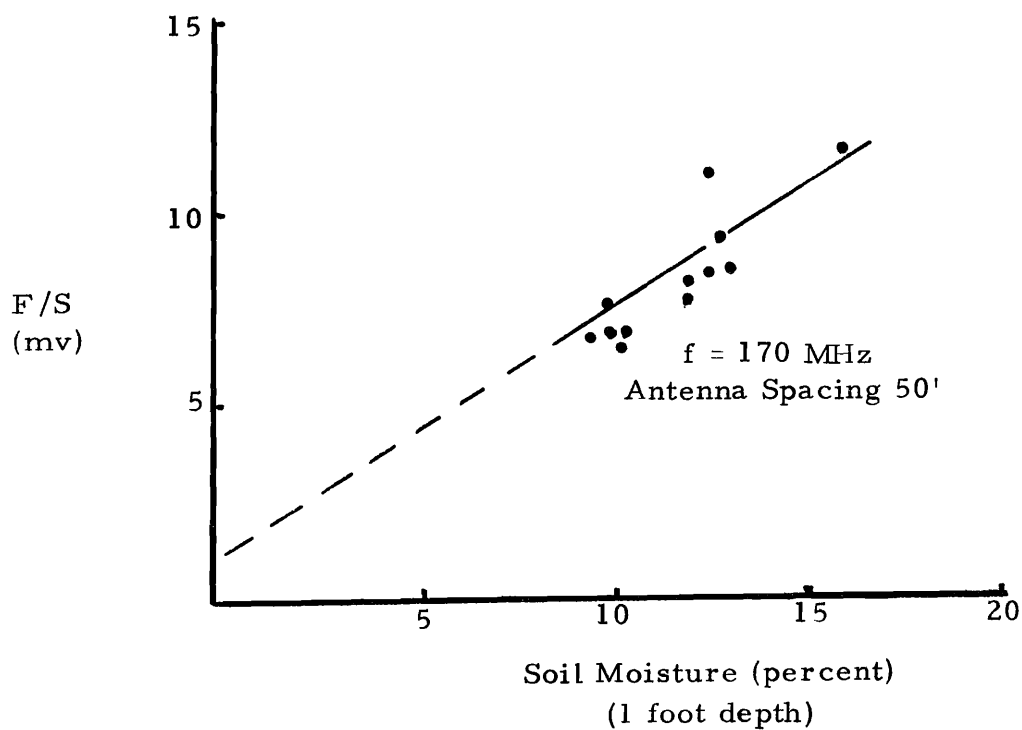

Figure 28. Rough plowed ground - Millville silt loam.

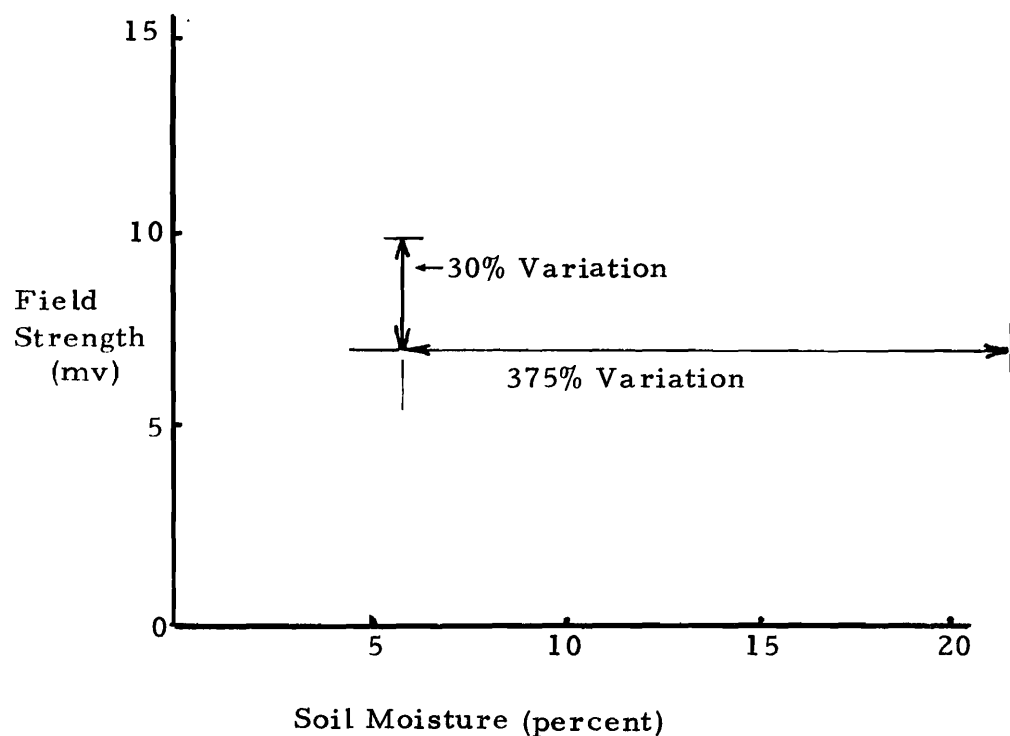

Figure 29. Soil moisture varies 375 percent between tree line and center line between trees. Radio field strength varies 30 percent over same area. This illustrates the degree to which the field strength method can give the "average" value. It should not be construed as being an insensitivity to soil moisture changes which is elsewhere proven to have approximately a 1 to 1 relationship.

The unique properties of soil moisture averaging by the radio wave attenuation method was shown by taking several soil moisture readings in the orchard as follows: Four soil moisture radio readings were taken. The antennas were first placed on the center line between rows, next they were placed one-third the distance from the center of the row to the tree line. Third, they were placed two-thirds the distance to the tree line, and fourth the antennas were placed directly in line with the trees. The trees were in full leaf at the time and orchard grass about 8-10 inches high was located primarily under the trees where most of the moisture was found. The results are shown in Figure 29. Even though the interpath vegetation varies greatly and soil moisture varies 375 percent, the field strength varied only 30 percent. This should not be construed as an insensitivity to detect soil moisture, since previous data show about a linear correspondence between soil moisture and field strength over the range of general interest. The data presented in Figure 29 does illustrate the degree to which the field strength method is able to average the variations of the soil moisture within the orchard. The data also illustrate that trees placed directly in line between the antennas do not greatly affect the signal strength. Using the parallel capacitor analogy and data of other test plots, the wet and dry areas should typically average out at the millivolt levels that were actually measured. Numerous other soil moisture tests were made on several other test sites giving essentially the same results as those presented.

Invariably the results were representative of soil moisture except where rank vegetative growth existed. The nature and magnitude of this problem are discussed in the following section.

Effects of vegetation on field strength

Unfortunately green vegetation has an adverse effect on soil moisture determinations by use of radio waves. The more dense the vegetation the more the signal strength is attenuated independently of soil moisture. The reason for this attenuation is difficult to analyze theoretically in a quantitative manner. In general terms it is known that green plants will tend to short out the electric (E) field since the vertical standing plant and the vertically polarized wave are in the same plane. Since the E field is partially terminated in a conducting corn stalk for example, energy losses occur since appreciable power is absorbed in the corn stalks.

The attenuation of the field strength in this manner can lead to the impression that the soil is dry when in fact, the reduced signal is caused principally by the presence of vegetation. To date this problem is not solved. There are several ways to partially overcome the problem, however, and several observations are made concerning them. Much vegetation is relatively constant in amount. In situations of this nature, the effect is present but constant and therefore its effect can be ignored as it is eliminated by the calibration process. Some types of vegetation does not seriously affect the signal. This may include orchards, range

lands, and crops that aren't too dense. The type of vegetation where it is most noticeable is the dense agricultural crops like mature alfalfa, or corn.¹

An experiment was conducted in order to illustrate the magnitude of the effect that mature, green rangeland grass had upon the signal strength, similar to that pictured in Figure 21. Initially the signal strength was 4.4 millivolts, the antenna separation was 50 feet, and the area to be mowed was 25 feet wide and 50 feet long between the transmitting and receiving antenna. The first 20 inch swath was mowed directly between the two antennas. Signal strength rose from 4.4 mv to 4.6 mv. A second swath was mowed and the field strength rose to 4.8 mv. At this point, the mowed grass was raked and removed from the area. After removal the signal remained unchanged at 4.8 mv. Subsequent mowed swaths caused the signal to increase to 7.5 mv. Thereupon additional mowings reduced the signal slightly until it stabilized at about 6.8 mv. The exact cause of the increased interim signal noted which was larger than the final value is believed to be due to the channeling or "wave guide" effect of the signal caused by the standing grass. Reflections from the standing grass were of sufficient magnitude and proper phase such that some signal enhancement was probably obtained. This

¹In some instances the growth rate of rank crops might be measured on a day to day basis by the day to day attenuation of the signal. Such a serendipity effect has not been evaluated.

same phenomenon has been noted several times in similar tests, thus discounting possible instrumentation error.

The interesting fact that raking and removing the grass had no measurable effect is worthy of note. Apparently the amount of water in the grass is not sufficient to change the signal unless the grass is standing vertical and thus parallel to the E-field as explained earlier. Adjacent to the mowed area there was a bare 25 ft x 50 ft plot which had been cleared the year before. The field strength in that plot was 11.2 mv. When compared to the plot just discussed with a field strength of 6.8 mv, it is easy to tell how much water was used by the plants. The actual value in percent moisture can be read from the graph in Figure 27. This can be approximately related to inches of water with the aid of Figure 20.

Instrument calibration

The results obtained to date indicate that a laboratory calibration of moisture by weight will not hold for different types of soil and vegetation. This requires that each area where the instrument is to be used will need to be calibrated. This is not difficult, but it does require that two bench marks be obtained; "wet" soil condition and "dry" or plant stress conditions. Thereafter experience to date shows that a linear relationship exists between these two end points provided that vegetation is either not too dense or that it does not change in density a great deal. Normally the wet soil condition can be most easily obtained

in the spring of the year or early summer after heavy rains or following an irrigation. The "dry" condition, of course, follows at a later date. Typically the "wet" soil signal is $2\frac{1}{2}$ - 3 times the "dry" soil condition so that if only one of the two bench marks are obtained the other can be predicted with fair accuracy. No attempt was made to calibrate moisture on a volume basis in lieu of a weight basis. From a theoretical standpoint, water expressed as a percent by volume should have a more nearly constant calibration coefficient for different types of soil. The degree to which this is achieved has not been determined.

Horizontal polarization

Since vertically oriented vegetation tends to reduce the field strength of the propagated wave, it is interesting to speculate whether or not a horizontally polarized radio wave could be used to minimize this problem. From a theoretical standpoint, there is much greater attenuation due to soil moisture for the horizontally polarized wave but the vertically standing vegetation should not have so great an effect.

Two pairs of horizontally polarized dipole antennas were built to test horizontal propagation, one at 27 MHz the other at 170 MHz. Tests showed the received field strength to be extremely sensitive to antenna elevation in each case. The degree of this sensitivity is illustrated in Figure 30. For comparative purposes, a second test was run where field strength versus antenna height was plotted for a vertically polarized 170 MHz antenna, Figure 31. As can be seen from these two figures, the field strength from the horizontally polarized antennas has a high

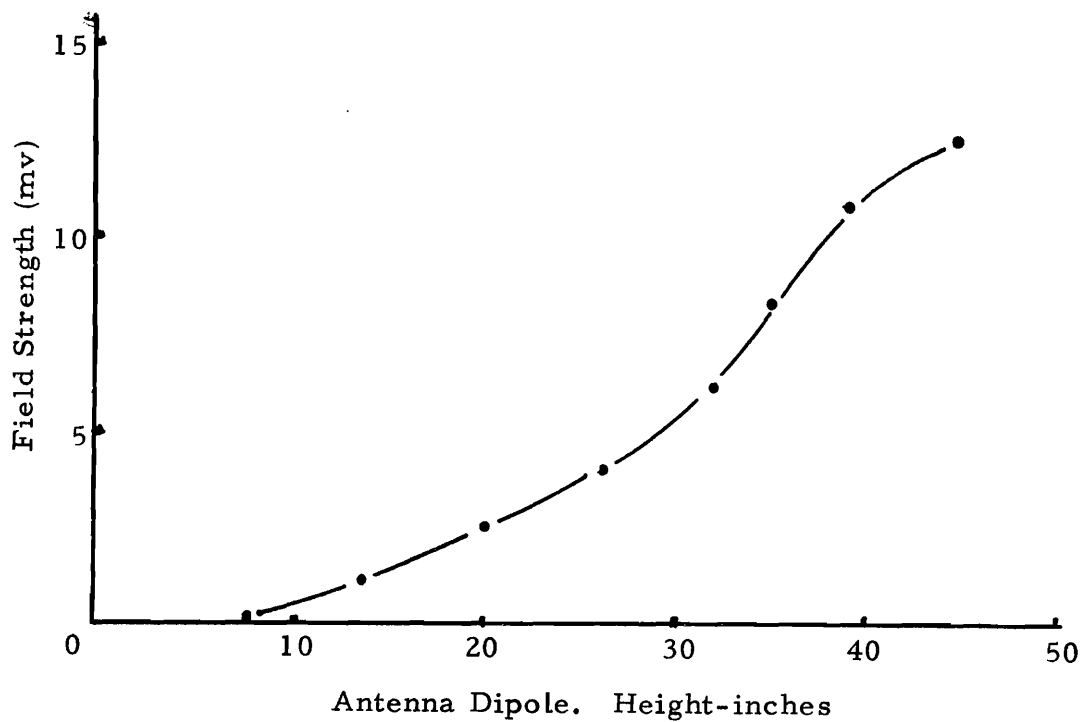

Figure 30. Signal strength versus horizontal dipole antenna height above ground. Frequency of test is 170 MHz, antenna spacing is 50 feet.

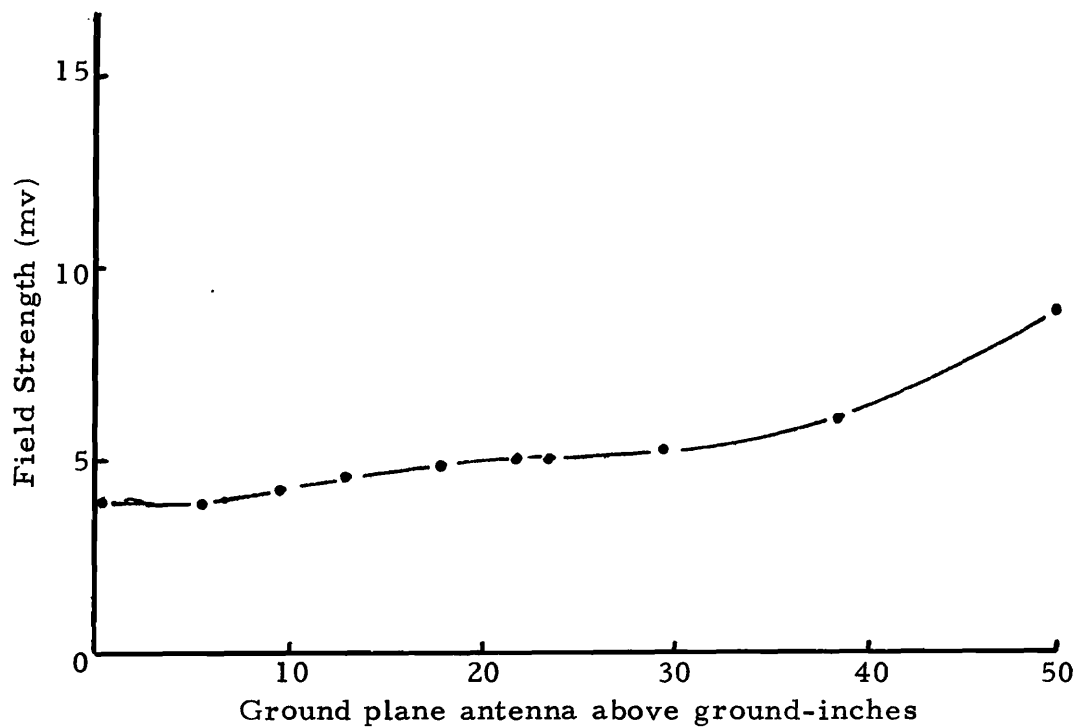

Figure 31. Signal strength versus antenna height above ground for 1/4 wave vertical antenna. Frequency of test is 170 MHz, and antenna spacing is 50 feet.

degree of dependence on antenna height, while field strength from the vertically polarized wave does not have much dependence, for low elevation. Because of this undesired phenomenon in the horizontal polarization case, further tests were not conducted. If the antennas were installed in a permanent manner, however, so that the elevation was not a variable, the horizontal polarization might yet prove useful in order to overcome sensitivity to vegetation. Unfortunately this approach was not thought of and tried until late in the project and it was not possible to pursue it further.

Comparison of 170 MHz data with 27 MHz data

The results obtained for the two frequencies, 170 MHz and 27 MHz, were remarkably similar. The 27 MHz tests were conducted chiefly over a 300 foot course length. The 170 MHz extended generally to only 50 feet. The fact that partially different soil was being sampled, plus errors of sampling, were considered adequate to account for any deviations noted. A comparison of the field strengths of the two frequencies is illustrated in Figure 32. These data were taken at two widely differing locations over a three month period of time. The standard error between them is 1.1 millivolts. In terms of soil moisture, it is about 1 percent, i. e., 7 percent versus 8 percent soil moisture, etc.

Notes on operational procedures

Numerous additional experiments were conducted regarding both technical and practical aspects of soil moisture monitoring. The

reduced by a factor of two, e. g., if power output is 10 percent above normal received signal strength calculates to be 4.9 percent above normal. Despite this "advantage" care should be exercised to maintain constant the radiated power.

5. Accurate antenna spacing is important and for comparative measurements the antennas should be placed in the exact same spot each time the measurements are made.
6. The antenna length is a fairly important parameter. It will not work well if bent, and it must be as near vertical as can be judged by the eye to work properly.
7. It does not matter appreciably if the antenna is wet or if it is raining at the time of the measurement.
8. The system is moderately sensitive to water distribution in the vertical plane. A more stable reading is obtained a few hours after a heavy rainfall when the soil moisture distribution is in a more stable state. This assumes that the original calibrations were also made with soil moisture in a quasi-stable state.
9. For vertical polarization, antennas can be elevated a quarter of a wave length above the surface to be measured without appreciably affecting the field strength.
10. The operation of a transmitter to measure soil moisture requires a license from the Federal Communications Commission, Washington, D. C.

SUMMARY

The results of this research demonstrate that the presence of soil moisture increases the field strength in direct proportion to the moisture present. Linearity between field strength and soil moisture is maintained over a wide range of interest pertaining to many plant requirements.

The propagated radio waves are launched from a transmitting antenna and detected some distance away by a receiving antenna. Consequently, this type of measurement can be considered as an integrated value of soil moisture since it samples the entire region between the antennas. If the moist soil is assumed to appear as a dielectric material between plates of a capacitor (the antennas in this case) its electrical behavior was shown to closely resemble the impedance characteristics of a capacitor.

Two electrical analogies of the properties of soil were made by assuming two nonhomogeneous soils existed which represented two capacitors of differing dielectrics in both the parallel and series configurations. The theoretical and measured field strength values were in very good agreement. Since the effective parallel dielectrics are additive, but the effective series dielectrics are inversely proportional to the sum of their individual reciprocal values, the good agreement obtained in each instance makes the analogy unique and well defined.

Since different soil types would probably have different intrinsic values of dielectric, each soil type may require a unique soil-moisture/field-strength calibration. Vertical polarization was chosen over horizontal polarization since horizontally polarized waves are attenuated very quickly and have considerable dependence on antenna elevation.

A chief disadvantage of the vertically polarized wave is that its magnitude is diminished by green, rank vegetation. The attenuation is not serious if the vegetation lies close to the ground or is not too dense as is mature alfalfa or tall corn. Reliable results were obtained in an orchard, range land, pasture land, golf course, etc.

Soil moisture in the top 2 to 3 feet of the soil has the dominant effect on the received field strength. Exact depth of radio wave penetration depends on magnetic permeability of the soil and the "skin effect," an electrical phenomenon which causes alternating currents to flow on the surface of a conductor, viz. the earth. Probably in no event would depth of penetration be appreciable below 5 to 10 feet at the radio frequencies used in this research.

The theoretical mathematical expression shows that the radio waves attenuate in an exponential fashion with soil depth, therefore, the radio waves are more affected by moisture in the top of the soil mantle than they are at the deeper extremities of their penetrable range.

Incremental changes in soil moisture were readily detectable after each rainfall. The sensitivity of the system to rainfall could thus

be of considerable benefit in assessing the effects of a storm. As a result of this information, irrigation practices could be adjusted to take economic advantage of such quantitative knowledge about the areal extent and the intensity of the storm.

The experimental results closely correlate with the theoretical analysis appearing in Appendix I. The analysis in Appendix I assumes given published values for the dielectric constant of "good" and "poor" soils which are functions of the water present. This function would logically correspond to volumetric water content rather than gravimetric water content. Because ready access was not always available to an instrument for measuring water by volume, the comparisons were made chiefly on a gravimetric basis. Had all soil moisture tests been made on a "volume" basis, the calibration curves may have had a more nearly uniform calibration curve, i. e., slope and intercept. This supposition has not been verified but it is substantiated by the capacitor analogy theory.

The system worked equally well at 27 MHz and at 170 MHz. The area of effect is proportional to the wave length and a minimum of 8 wave lengths spacing between antennas are required to approach the ideal maximum to minimum signal ratio for the wet to dry soil range.

RECOMMENDATIONS FOR CONTINUED RESEARCH

The rapidity and ease with which the discussed method can be used as well as its obvious application for large-scale area measurement and remote sensing would appear to justify further research. Better definition of depth-of-soil being measured is needed. Ways of overcoming attenuation by rank vegetation is desirable and may be possible. Horizontally polarized waves may provide better results in these cases.

The phenomenon of normally unwanted attenuation caused by vegetation might be usefully used for an integrated measurement of crop growth rates, provided soil moisture was brought to some known value each time the vegetation measurement was to be made. Another approach would be to make a moisture depletion allowance when measuring crop growth. The possibility for using field strength measurements to measure crop growth appears sufficiently promising to warrant further research.

BIBLIOGRAPHY

- Ballard, L. F. 1970. Instrumentation for measurement of moisture. Prepared for Highway Research Board, National Cooperative Highway Research Program, National Academy of Science, Period ending August 26, 1970. Final Report Project No. HR-21-1.
- Jordan, E. C. 1950. Electromagnetic waves and radiating systems. Prentice Hall.
- Josephson, B., and A. Blomquist. 1958. The influences of moisture in the ground, temperature and terrain on ground wave propagation in the V.H.F. -band. I.R.E. Trans. Antennas and Propagation AP-61(2):169-72, April.
- Kraus, J. D. 1950. Antennas. McGraw-Hill.
- Norton, K. A. 1936. The propagation of radio waves over the surface of the earth and in the upper atmosphere. Proc. I.R.E. 24:1367. October 1936. and The calculation of ground-wave field intensity over a finitely conducting spherical earth. Proc. I.R.E. 29:623. December 1941.
- Sommerfeld, A. 1909. The propagation of waves in wireless telegraphy. Ann. Physik. 28:665. March.
- Terman, F. E. 1943. Radio engineers handbook. McGraw-Hill. p. 674.
- Terman, F. E. 1955. Electronic and radio engineering. McGraw-Hill. p. 803.

APPENDIX I

SIGNAL STRENGTH CALCULATIONS

Calculations for determining expected received signal strength as read by a field strength meter are important in preliminary system design. Once a particular transmitter and transmitting power and frequency are specified, the field strength expected at some distance away can be determined by calculation. Such a determination will aid in the design of a field strength meter to be used in measuring the received signal. This information will assist in optimizing transmitter configuration and costs against field strength, circuit configuration, and costs. To illustrate how this might be optimized it is possible to build either a very powerful transmitter costing x dollars so that an inexpensive, e.g. a diode and meter can be used as a field strength meter or conversely perhaps a simple inexpensive micropower transmitter should be used in conjunction with an extremely sensitive field strength meter. This concept is illustrated in Figure 33. Care should be used in its interpretation as the information is subjective; however, this type reasoning prevailed when transmitter and F.S. meter were being designed.

Theoretical calculations for determining the strength of field in volts/meter at the antenna are a first step to computing signal levels derived from the antenna. In order to calculate it, several parameters must be given:

Field Strength Meter Sensitivity mv/meter

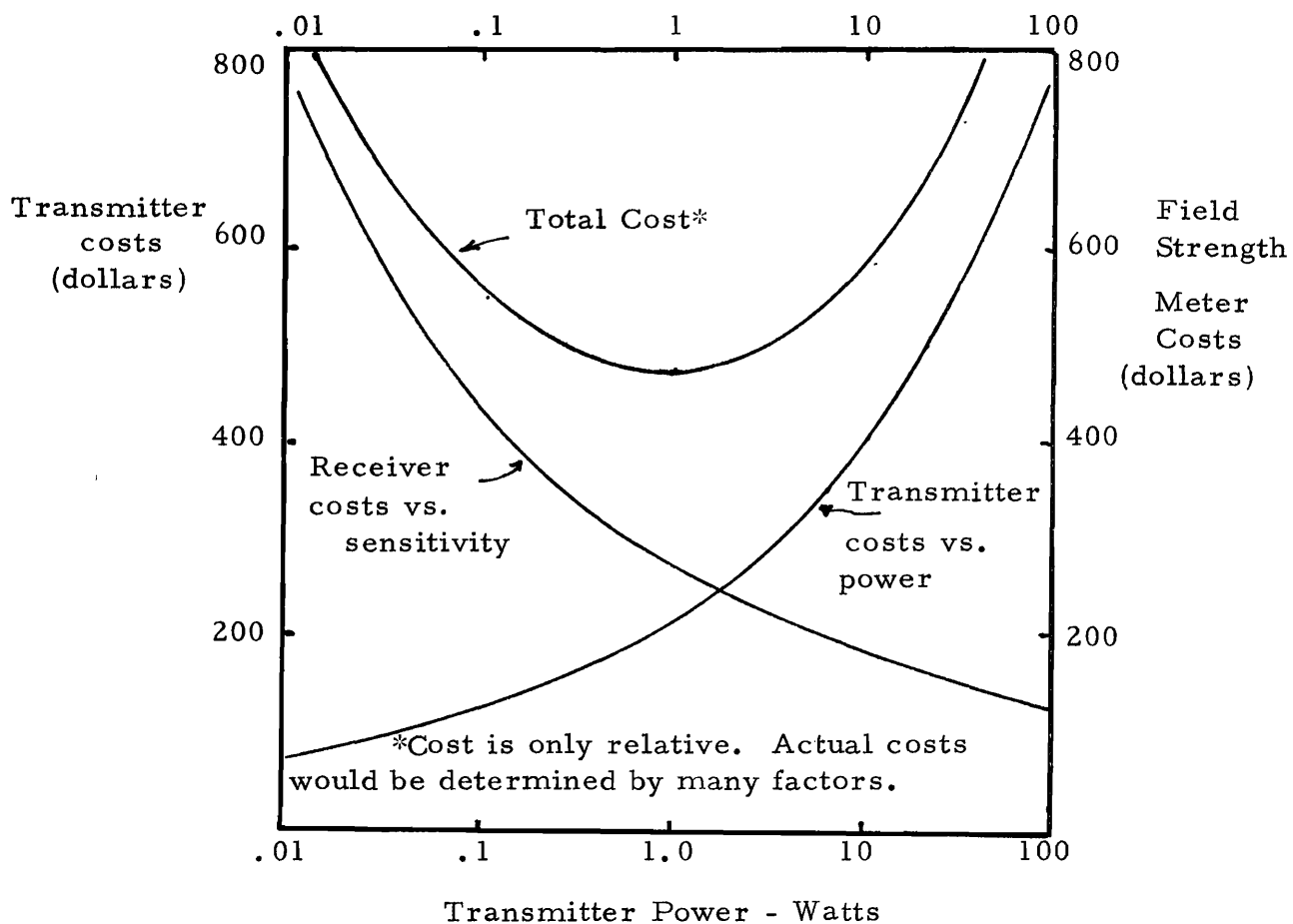

Figure 33. Estimate of relative costs of transmitter and field strength meter and trade offs possible between them. Sketch indicates an optimum (lowest cost) exists when using "moderate" power and "moderate" field strength meter sensitivity.

1. Transmitter frequency is 170 MHz.
2. Antennas are $\lambda/4$ vertical ground-plane types placed directly on the ground.
3. Antenna spacing is 50' (15.24 meters).
4. Transmitter power is 1 watt into a 50' long RG-58 coax cable feeding a $\lambda/4$ antenna.
5. The receiver (field strength meter) is connected to its antenna by a similar 50' coax.

Other assumptions that must be made are that (1) the dielectric of the soil is 14 corresponding to moist pastoral land in Ohio, and (2) soil conductivity is 1×10^{-4} mhos/cm.

A vertical $\lambda/4$ antenna, having a field strength E at a distance d , assuming a perfectly conductive soil surface, can be expressed by the equation (Kraus, 1950),

$$E(\alpha, r) = \frac{60}{r} \sqrt{\frac{W}{R_{11} \times R_{1L}}} \frac{\cos(l_r \sin \alpha) - \cos l_r}{\cos \alpha} \quad \dots \dots \dots (16)$$

in which

- l = antenna height
- α = angle from horizontal
- r = distance to some point p
- l_r = $(2\pi/\lambda)l$

R_{11} = self-resistance of vertical antenna

R_{1L} = effective loss of antenna

W = power input to antenna

Simplifying, for the case where $\alpha = 0$ and the self-resistance

$R_{11} = 36$ ohms,¹ and R_{1L} is assumed to be zero:

$$E = \frac{60}{r} \sqrt{\frac{W}{36.5}} \dots \dots \dots (17)$$

$$E = \left(\frac{60}{15.24 \text{ meters}} \right) \left(\sqrt{\frac{1}{36.5}} \right) (\cos 0^\circ)$$

$$= .652 \text{ volts/meter.}$$

Since there is a 3db loss of transmitter power delivered to the antenna, caused by the 50 feet of interconnecting coax cable this reduces the voltage by $\frac{1}{\sqrt{2}}$ therefore

$$E = .652 \times \frac{1}{\sqrt{2}} = .455 \text{ volts/meter.}$$

Equation 2 gives the field strength without taking into account the ground losses which are appreciable. The ground losses are calculated using notation from page 6 of the report.

¹For radiation constant see Kraus (1950, p. 315).

$$p = \left(\pi \frac{d}{c} \right) \left(\frac{f}{\epsilon_r + 1} \right) = \pi \left(\frac{15.24}{300 \times 10^6} \right) \left(\frac{170 \times 10^6}{15} \right) = 1.8$$

. (18)

Using the relationship plotted in Figure 1 the value A corresponding to p of 1.8 and an angle b of

$$\tan b = \frac{\epsilon + 1}{x} = \frac{(14 + 1) 170 \times 10^6}{(1.8 \times 10^{12}) (10^{-4})} = b = 82^\circ$$

gives,

$$A = 0.23$$

and the field strength is

$$\text{Field strength} = (.23)(.455) = .104 \text{ volts/meter}$$

The field strength can also be expressed in terms of volts per wave length giving:

$$\begin{aligned} \text{Field strength} &= (\text{volts/meter}) \left(\frac{\text{speed of light}}{\text{frequency}} \right) \\ &= (.104) \frac{300 \times 10^6}{170 \times 10^6} = .187 \frac{\text{volts}}{\text{wave length}} \end{aligned}$$

Since the impedance of free space is 120π , the power density P_d is

$$P_d = \frac{.187 v/\lambda^2}{120 \pi} = 92.6 \frac{\mu w}{\lambda^2}$$

To convert the power density at the receiving antenna to a voltage at the termination impedance (R_1 , Figure 34) the effective antenna aperture (A_e) must be determined. (The antenna aperture is the ratio of the power in the terminating resistors, R_1 , to the effective power in the space around the antenna.) The value of the antenna aperture is determined by integrating the field strength at the antenna. Figure 34 shows that

$$\begin{aligned} dV &= E dy \cos \frac{2\pi y}{\lambda} \\ V &= \int_0^{\lambda/4} E \cos \frac{2\pi y}{\lambda} dy \\ V &= \frac{E\lambda}{2\pi} \dots \dots \dots (19) \end{aligned}$$

The power in the terminating resistor R_1 can now be calculated. For maximum power transfer the load resistance should be equal to the antenna impedance, thus

$$R_{\text{antenna}} = R_{\text{load}} = R$$

The power in the load (P_1) is now expressed as

$$P_1 = \frac{V^2 R}{4R^2} \dots \dots \dots (20)$$

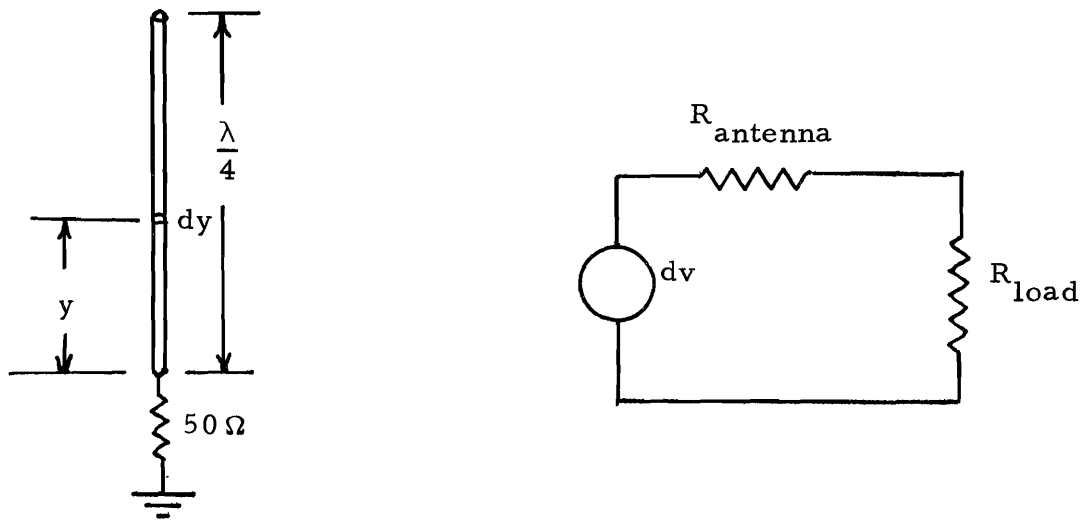

Figure 34. A $\lambda/4$ antenna terminated in 50 ohms. The antenna and load is represented as a Thevenins equivalent circuit.

Recalling that the antenna aperture (A_e) is the ratio of P_1 to the effective power in the space around the antenna, and substituting in Equation 20 gives

$$A_e = \frac{V^2 R}{4R^2 P} = \frac{E^2 \lambda^2 120 \pi}{(4\pi^2)(4)(E^2)(50)} = .0478 \lambda^2$$

in which P is equal to the field strength divided by the impedance of free space, 120π .

Neglecting cable loss in the receiver antenna, the power delivered to the load is

$$\left(92.6 \frac{\mu\text{W}}{\lambda^2}\right) (.0478 \lambda^2) = 4.42 \mu\text{W}$$

Since,

$$P = \frac{V^2}{50}$$

the load voltage is

$$V = \sqrt{50 \times 4.42 \mu\text{w}} = 14.9 \text{ mv}$$

Considering a 3db loss in the receiver cable (50' of RG58)

$$V = \sqrt{50 \frac{4.42}{2} \mu\text{w}} = 10.5 \text{ millivolts}$$

The calculation used above assumes a soil moisture such that the dielectric constant would be $\epsilon = 14$. A signal of 10.5 millivolts is well within the capability of the field strength meter and thus the operating ranges chosen for antenna-transmitter power and field strength meter capability appear to be a good choice. As a matter of interest the 10.5 mv level correlates very closely with actual field measurements as can be seen in the body of the report.

