

Utah State University

DigitalCommons@USU

All Graduate Theses and Dissertations

Graduate Studies

8-2012

Waste Heat Utilization in an Anaerobic Digestion System

Brett Boissevain
Utah State University

Follow this and additional works at: <https://digitalcommons.usu.edu/etd>



Part of the [Aerospace Engineering Commons](#)

Recommended Citation

Boissevain, Brett, "Waste Heat Utilization in an Anaerobic Digestion System" (2012). *All Graduate Theses and Dissertations*. 1266.

<https://digitalcommons.usu.edu/etd/1266>

This Thesis is brought to you for free and open access by the Graduate Studies at DigitalCommons@USU. It has been accepted for inclusion in All Graduate Theses and Dissertations by an authorized administrator of DigitalCommons@USU. For more information, please contact digitalcommons@usu.edu.



WASTE HEAT UTILIZATION IN AN
ANAEROBIC DIGESTION SYSTEM

by

Brett Boissevain

A thesis submitted in fulfillment
of the requirements for the degree

of

MASTER OF SCIENCE

in

Mechanical Engineering

Approved:

Dr. Byard Wood
Major Professor

Dr. Ron Sims
Committee Member

Dr. Barton Smith
Committee Member

Dr. Mark R. McLellan
Vice President for Research and
Dean of the School of Graduate Studies

UTAH STATE UNIVERSITY
Logan, Utah

2012

Copyright © Brett Boissevain 2012

All Rights Reserved

ABSTRACT

Waste Heat Utilization in an
Anaerobic Digestion System

by

Brett Boissevain, Master of Science

Utah State University, 2012

Major Professor: Dr. Byard D. Wood
Department: Mechanical Engineering

Anaerobic digestion is a well-researched topic that has been utilized for centuries. While the theoretical understanding is solid, many real world systems often suffer due to poorly designed operation and equipment. This thesis uses a computer modeling approach to consider a real world system that is subpar, and identifies how it might be improved. First, a computer model is developed to mimic the real world system. Next, major elements (heat exchanger efficiencies, biogas utilization) are modified to show potential outcomes on system performance. The main outcome of this research is to show the importance of waste heat utilization in an anaerobic digestion system, and how if properly applied it can lead to an energy independent operation.

(120 pages)

PUBLIC ABSTRACT

Waste Heat Utilization in an
Anaerobic Digestion System

by

Brett Boissevain, Master of Science

Utah State University, 2012

Major Professor: Dr. Byard D. Wood
Department: Mechanical Engineering

Anaerobic digestion has great potential as an energy source. Not only does it provide an effective method for waste mitigation, but it has the potential to generate significant quantities of fuel and electricity. In order to ensure efficient digestion and biomass utilization, however, the system must be continuously maintained at elevated temperatures. It is technically feasible to supplement such a system with outside energy, but it is more cost effective to heat the system using only the produced biogas. While there is considerable literature covering the theory of anaerobic digestion, there are very few practical studies to show how heat utilization affects system operation. This study considers the effect of major design variables (i.e. heat exchanger efficiencies and biogas conditioning) on promoting a completely self-sustaining digestion system. The thesis considers a real world system and analyzes how it can be improved to avoid the need of an external energy source.

ACKNOWLEDGMENTS

I gratefully acknowledge the financial support of the US Department of Energy, as well as the Department of Mechanical and Aerospace Engineering at Utah State University.

I thank those family members, colleagues, and the project advisor who have provided the tireless guidance needed to accomplish this study.

Brett L. Boissevain

CONTENTS

	Page
ABSTRACT.....	iii
PUBLIC ABSTRACT	iv
ACKNOWLEDGMENTS	v
LIST OF TABLES.....	ix
LIST OF FIGURES	x
NOMENCLATURE	xii
INTRODUCTION	1
1.1 Introduction.....	1
1.2 Problem Statement.....	1
1.3 Project Background.....	2
1.4 Methodology.....	3
1.4.1 Initial Modeling.....	3
1.4.2 Model Validation	4
1.5 Objectives	4
BACKGROUND AND LITERATURE REVIEW.....	6
2.1 Background.....	6
2.2 Process	6
2.2.1 Pathway.....	6
2.2.2 Kinetics	7
2.2.3 Relevant Organisms	7
2.2.4 Environmental Conditions	8
2.2.5 Feedstock Effects	9
2.3 Reactor Design.....	10
2.3.1 General Model.....	11
2.3.2 Residence Time.....	13
2.3.3 Productivity and Optimization	14

DIGESTER SYSTEM	16
3.1 Sunderland System	16
3.2 System Environment and Capacity	17
3.3 Upstream.....	18
3.3.1 Hydrating	18
3.3.2 Heating	19
3.4 Digester.....	20
3.4.1 Flow and Operation.....	20
3.4.2 External Systems	21
3.5 Downstream.....	22
3.5.1 Solid and Liquid Waste.....	22
3.5.2 Gas	23
3.6 Controls and Monitoring.....	24
PERFORMANCE ANALYSIS	25
4.1 Performance Analysis	25
4.2 TRNSYS Model Details	26
4.3 System Heating Design and Operation	28
4.3.1 Waste Heat Recovery	29
4.3.2 Primary Heat Loop.....	30
4.4 Biogas Production and Use.....	31
4.5 Simulation Inputs.....	33
4.6 TRNSYS Model Validation.....	36
4.6.1 Temperature	37
4.6.2 Heat Exchanger Efficiencies	39
4.6.3 Biogas Production	40
POTENTIAL SYSTEM IMPROVEMENTS	42
5.1 Potential System Improvements	42
5.2 Waste Heat Recovery.....	42
5.3 Main Shell and Tube Heat Exchanger	44
5.4 Exhaust Shell and Tube Heat Exchanger.....	46
5.5 Biogas Use.....	46
5.6 Effects of Multiple Improvements	48

5.6.1	WHR with Respect to Others.....	51
5.6.2	Main Shell and Tube with Respect to Others.....	52
5.6.3	Exhaust Heat Exchanger with Respect to Others.....	54
CONCLUSIONS AND RECOMMENDATIONS		56
6.1	Conclusions.....	56
6.2	Recommendations.....	57
REFERENCES		59
APPENDICES		61
APPENDIX A – EMPIRICAL ANALYSIS		62
A.1	Tank Loss Coefficient.....	63
A.2	Building Loss Coefficient	66
A.3	Engine Exhaust Flow	68
A.4	Dual Pipe Counter Flow Heat Exchanger	70
A.5	Shell and Tube Heat Exchanger.....	74
APPENDIX B – SDDS DIAGRAM		78
APPENDIX C – TRNSYS ANALYSIS.....		79
C.1	Methodology	79
C.2	Components.....	80
C.2.1	Equation Editor	80
C.2.2	Weather Data Reader	81
C.2.3	Building	82
C.2.4	Tanks.....	84
C.2.5	Heating and Cooling	89
C.2.6	Heat Exchangers	95
C.2.7	Engine-Generator.....	98
C.2.8	Controllers	100
C.2.9	Data Output.....	102
C.3	Subsystems.....	102
C.3.1	Digester Tanks	103
C.3.2	Biogas Generation and Use.....	104
C.3.3	Heat Loop	105
C.4	Full Model.....	106

LIST OF TABLES

Table	Page
1 - Upstream TRNSYS Inputs	34
2 - Digester TRNSYS Inputs	35
3 - Downstream TRNSYS Inputs	36

LIST OF FIGURES

Figure	Page
1 - Cutaway of IBR (Left) and CSTR (Right) (Adapted from [1]).....	11
2 - Digester Mass Balance	13
3 - SDDS Process Flow (Adapted from [3]).....	16
4 - Tank Temperatures	26
5 - SDDS Heating Schematic.....	29
6 - Biogas Use.....	32
7 – Biogas Production (Adapted from [3])	33
8 – Tank and Pit Temperature Comparison	38
9 - Building Temperature.....	39
10 - Biogas Production from TRNSYS	41
11 - Waste Heat Recovery Optimization	43
12 - Main Shell and Tube Heat Exchanger Efficiency	44
13 - Tank Temperature Profiles for Main ST Improvements	45
14 - Exhaust Shell and Tube Heat Exchanger Efficiency	47
15 - Engine Power Output.....	49
16 - WHR Improvements after Biogas Conditioning	49
17 - Main ST Improvements after Biogas Conditioning.....	50
18 - Exhaust Exchanger Improvements after Biogas Conditioning.....	50
19 - WHR wrt Main ST	51
20 - WHR wrt Exhaust.....	52
21 - Main ST wrt WHR	53

22 - Main ST wrt Exhaust.....	53
23 - Exhaust wrt WHR.....	54
24 - Exhaust wrt Main ST.....	55
25 - SDDS Schematic	78
26 - Digester System.....	103
27 - Gas Production System.....	104
28 - Heat Loop System	105
29 - Full System.....	107

NOMENCLATURE

AD	Anaerobic Digestion
B_0	Ultimate Biogas Yield (m^3 biogas kg^{-1} VS fed)
CH_4	Methane
cm	Centimeter
CO_2	Carbon Dioxide
COD	Chemical Oxygen Demand
CSTR	Continuous Stirred Tank Reactor
dX/dt	Change in Anaerobic Bacteria Cell Concentration over Time
dS/dt	Change in Substrate Concentration over Time
F	Flowrate (m^3/day)
Gpm	Gallons Per Minute
H_2O	Water
H_2S	Hydrogen Sulfide
HRT	Hydraulic Retention Time (days)
IBR	Induced Blanket Reactor
K	Dimensionless Kinetic Parameter
K_d	Endogenous Metabolism Rate
LHV	Lower Heating Value (kJ/m^3)
m	Meter
mm	Millimeter
q_p	Rate of Product (Methane) Formation

S	Reactor Volatile Solids Content (kg VS m ⁻³)
S ₀	Influent Volatile Solids Content (kg VS m ⁻³ influent)
SDDS	Sunderland Dairy Digester System
SRT	Solids Retention Time (days)
ST	Shell and Tube
TMY	Typical Meteorological Year
μ _g	Anaerobic Bacteria Cell Growth Rate
μ _m	Maximum Specific Growth Rate of the Microorganisms (day ⁻¹)
UASB	Upflow Anaerobic Sludge Blanket
USU	Utah State University
V _R	Reactor Volume (m ³)
V _s	Specific Methane Production Rate (m ³ biogas m ⁻³ reactor day ⁻¹)
VS	Volatile Solids
WHR	Waste Heat Recovery
wrt	With Respect To
X	Reactor Anaerobic Bacteria Cell Concentration
X ₀	Influent Anaerobic Bacteria Cell Concentration
Y _{P/S}	Volatile Solids to Methane Yield
Y _{X/S}	Volatile Solids to Anaerobic Bacteria Yield

INTRODUCTION

1.1 Introduction

Anaerobic digestion is rapidly growing as a research topic at Utah State University [1-3]. Especially with today's environmental and energy concerns, anaerobic digestion presents a very attractive option for sustainable energy production. Anaerobic digesters operate by converting some form of biomass (e.g. dairy manure, algae, food wastes) into biogas (generally 70% methane and 30% carbon dioxide, and other trace gasses) [1]. Methane can be used as a fuel source either for heating or for running an engine-generator to produce electricity.

What many enthusiasts fail to realize, however, is that while anaerobic digestion may produce "free" energy it still requires a significant amount of heat to operate the system. Anaerobic bacteria can only function within certain temperature ranges, and any major fluctuation can severely hinder digester operation. The most common operating temperatures for large scale anaerobic digestion fall in the mesophilic range (30-35 °C) [4]. Efficient operation requires that the digester volume be maintained at this elevated temperature if significant gas production is to be expected.

1.2 Problem Statement

There are many industries in which waste mitigation presents a serious burden. If the waste consists of biomass then anaerobic digestion (AD) presents a very appealing solution. A problem with AD, however, is that if the system is not properly designed it can be more costly to operate than the traditional waste disposal techniques (e.g. shipping to a landfill, open air degradation). A poorly designed, real world, AD system, especially in climates with cold winter months, will not function year round without some external energy source. Even if sufficient biogas is produced, poor heat utilization can limit temperature potentials, especially in colder climates. It is therefore important to identify common system shortcomings in order to improve system performance and

achieve a more feasible year round operation. This includes available heat utilization and biogas production.

1.3 Project Background

AD is well understood from a theoretical approach. There are many published articles developing reliable rate equations that predict biomass conversion and gas production based on influent characteristics and operating conditions [3-6]. There are very few studies, however, that consider how such a system is maintained and operated. There are many process variables that have a significant effect on system performance. Some examples of these variables include retention time, feedstock characteristics, and operating temperature. The objective of this study was to perform a sensitivity study on major system variables and define how each affects the performance of a typical AD system. This was accomplished through the development of a computer simulation model that accurately mimics an existing system, and then investigates the system response to changes in the major variables such as biogas utilization and heat utilization.

The real world system of interest for this study is the Sunderland Dairy Digester System (SDDS). SDDS is an AD system that uses four 120 m³ digester tanks to convert dairy-cow manure to methane [2-3, 7-9]. The SDDS has been the subject of many USU research projects since its inception in 2004, resulting in many studies and retrofit projects. From this past work it is possible to develop an understanding of the current system performance. Details are collected not only from related publications and reports, but also conversations with the system operator and hands on analysis of the system design and operation.

Digester heating is provided by waste heat from an engine-generator that converts the produced biogas into electricity. This waste heat is transferred to the digesters through a series of custom heat exchangers. According to the system operator, Scott Sunderland, the digesters are

currently operational from mid-April to early-November. The winter months are too cold to maintain temperatures without supplemental heat.

1.4 Methodology

The method for analyzing system performance is through a software package known as TRNSYS (Transient System Simulation Tool) [10]. This software package was originally developed through the University of Wisconsin's Solar Laboratory in order to evaluate various solar energy projects. Since its creation, this software has found a much wider use in many other energy topics, now including anaerobic digestion. The TRNSYS software is first used to generate a model that mimics the existing SDDS configuration. Various elements of the model are then modified to identify how year-round potential may be improved. The results of this modeled simulation led to straight forward and reliable recommendations on how to improve the system operation.

1.4.1 Initial Modeling

TRNSYS is an extensible simulation environment used to evaluate complex energy systems. The program itself operates on a library of components programmed to simulate real world equipment and processes. The available components consist of things such as pumps, heat exchangers, thermal storage tanks, and other common equipment. The component library included with TRNSYS has almost everything needed to model the SDDS. For highly specific elements such as biogas production as a function of feedstock, TRNSYS offers easily modifiable, open source components so a user can simulate unique phenomena. In order to model the system, information is obtained from design reports, published literature and site operators.

1.4.2 Model Validation

While the developed model can be modified to closely model the real world system, as with any model the match will not be exact. Reasons for this include that the model cannot account for the day to day difficulties encountered by an operator. These difficulties range from unpredictable weather patterns to equipment malfunction and maintenance requirements. While many studies are concerned with absolute values and results, this study is only concerned with relative system responses and how best to improve the systems operation for a given set of environmental conditions. Data from past studies can be used to confirm model output, but because of the nature of this study exact results are not necessary.

1.5 Objectives

The objectives of this study were to:

- 1) Develop a simulation model that mimics an existing anaerobic digestion system, and validate the model through comparison to real system data.
- 2) Use the validated model to perform a sensitivity study on the major design variables (e.g. heat utilization, biogas use) and their effect on the performance of the digestion system.
- 3) Make recommendations regarding how best to improve the digestion system to achieve year round operation without the need of an external energy source.

To accomplish these objectives, several things must be considered. First, the fundamentals of anaerobic digestion are presented to identify important factors for optimum digestion. Secondly, the layout and operation of SDDS is discussed to gain a clear understanding of the real world system to be modeled. Third, the specific elements of interest in this study that have been identified for potential improvements are analyzed. Fourth, effects of improvements to the identified elements are modeled to show which changes present the most promising

improvements. Finally, to summarize, conclusions and recommendations are made for how best to improve the real world digester system at the Sunderland Dairy.

BACKGROUND AND LITERATURE REVIEW

2.1 Background

AD is a process that has proven itself valuable in both waste treatment and energy generation [1, 4-5]. Through the process of organic solids reduction, the byproduct of methane gas can be harnessed as a potential energy source. The process itself is series of microbial steps that converts the biomass from complex organic substrates to a simple methane product. Several different types of bacteria are involved in this sequential break down. This section first investigates the details of the process, and then walks through the important factors in reactor design and operation.

2.2 Process

The complexity of the incoming biomass requires an equally intricate collection of bacteria to handle the conversion to methane. The biomass consists of many complex carbohydrates, lipids and proteins. None of these can be directly converted to biogas. Through the anaerobic food chain, however, these complex molecules are sequentially simplified until finally biogas (primarily methane and carbon dioxide) is obtained. The three generic stages of AD are defined as hydrolysis, acetogenesis and methanogenesis [4]. To understand the process, it is important to consider the biochemical pathway, the cell growth kinetics, relevant organisms, required environmental conditions, and feedstock effects.

2.2.1 Pathway

The overall process can be simplified into a sequential pathway involving three general groups of bacteria: fermentative, acetogenic and methanogenic [4]. The fermentative bacteria are responsible for converting the complex organic compounds to simple, soluble organic compounds such as volatile acids and alcohols (a process also known as hydrolysis). The acetogenic group

then reduces these simple compounds into acetic acid and hydrogen gas. Finally, the methanogenic bacteria complete the process by converting the acetic acid and hydrogen gas into methane and carbon dioxide.

2.2.2 Kinetics

A rough estimate of methane production can be obtained based solely on digester size and residence time, but incorporating functions of bacterial growth can give much more accurate results [5]. There are many models that can be applied. A proven and reliable model is the Contois Model, as utilized by Gunnerson and Stuckey [5], and is shown in Eq. (1).

$$V_s = \frac{B_0 * S_0}{HRT} * \left(1 - \frac{K}{HRT * \mu_m - 1 + K} \right) \quad (1)$$

In the equation, V_s is specific methane production rate (m^3 biogas m^{-3} reactor day^{-1}), B_0 is the ultimate biogas yield (m^3 biogas kg^{-1} VS fed), S_0 is influent volatile solids content (kg VS m^{-3} influent), K is a dimensionless kinetic parameter, and μ_m is the maximum specific growth rate of the microorganisms (day^{-1}).

2.2.3 Relevant Organisms

There are many different strains of methanogenic bacteria. Different strains are optimized at different operational conditions. For example, at a given temperature and pH, one strain of bacteria will out-produce another. Typically, methanogenic strains are classified into three groups. These groups are categorized by the substrate used, and are named hydrogenotrophic, acetotrophic and methylotrophic methanogens [4].

Hydrogenotrophic bacteria use hydrogen to convert carbon dioxide to methane. This group is vital to the acetogenic bacteria in that they preserve a low partial pressure of hydrogen in the digester. If hydrogen were to build up, acetogenic bacteria would be inhibited and digester

performance would fail. The acetotrophic group reduces acetate into methane and carbon dioxide. An intermediate step also produces more hydrogen, for use by the hydrogenotrophic group. Similar to acetogenic bacteria, the acetotrophic methanogens are extremely sensitive to hydrogen partial pressure. Therefore, hydrogenotrophic methanogens are important not only for acetate forming bacteria, but also for acetate splitting methanogens. Unlike the previous two groups, methylotrophic methanogens do not use CO_2 to produce methane. Instead, they utilize substrates containing the methyl group $-\text{CH}_3$ (such as methanol and methylamines).

2.2.4 *Environmental Conditions*

The rate-limiting step in the anaerobic food chain is the methane forming bacteria, specifically the conversion of volatile acids to methane [4]. A reason for this is that methanogens gain very little energy from the conversion, as most of the energy released from the volatile acids is transferred directly to the methane. Because of this low energy gain, methanogenic bacterial growth rates are relatively slow. This low growth rate results in a serious sensitivity to environmental conditions. Any major upset in conditions will cause a decline in methanogen population, requiring long periods for the bacteria to return to normal levels. Methanogens are strict anaerobes and show the greatest sensitivity to temperature, alkalinity and pH [4]. Bacteria that exist in the anaerobic digestion process can be classified by their operating temperatures. Mesophilic bacteria, for example, operate best in the temperature range of 30 to 35°C, while thermophilic bacteria work best in the 50 to 60°C range [4]. There are certain tradeoffs that come from operating within each range. While thermophilic conditions may require lower residence times, they also require much higher heating costs and often show decreased stability and higher sensitivity to minor temperature fluctuations [1]. The operating temperature, however, is not as important on digestion performance as temperature fluctuations. As discussed

by Gunnerson et al., anaerobic bacteria are able to adapt to moderately adverse conditions. An immediate response to the temperature fluctuation will temporarily limit methane production while increasing volatile acid production [4]. This high acid concentration will further inhibit the adaptability of methanogenic cultures to the new temperatures. As previously mentioned, different methanogenic strains are optimized at different temperatures, giving rise to the different temperature classifications (i.e. mesophilic and thermophilic).

Similar to temperature requirements, methanogenic bacteria require a stable operating pH. Optimum pH ranges are fairly neutral (ranging from 6.8 to 7.2) [4]. Some strains are optimized at slightly basic levels, while others are optimized at slightly acidic levels. Alkalinity is one of the most significant factors in maintaining a stable pH, as it acts as a buffer against rapid pH change. Alkalinity ratios are often used as an indicator of digester performance. A drop in alkalinity is a good indicator of a pending failure [4]. Drops in alkalinity are usually caused by accumulation of organic acids, resulting from either influent compositional change or inhibition of methane forming bacteria (and a subsequent failure of converting organic acids to methane).

2.2.5 *Feedstock Effects*

Another factor affecting digester performance is the composition and rate of the incoming biomass. The feedstock must provide sufficient nutrients for the bacteria, while not overloading them with others. Also, different feedstocks have different biological structures, affecting the biodegradability and accessibility of the nutrients. Feed rates are often defined in terms of percent volatile solids loading rates. Too low of a concentration will result in hydraulic overload, meaning the methanogens cannot reproduce fast enough to avoid being flushed out of the digester (this is only a concern with continuous operation, batch operation is not subject to this problem).

Too high of a concentration, however, will cause organic overload. In other words, this will lead to a toxic buildup of nutrients (usually caused by nitrogenous compounds) [5].

Anaerobic bacterial growth and performance is dependent on adequate presence of macronutrients such as nitrogen and phosphorous. Nitrogen has two major roles as an important macronutrient [5]. First, it is essential in the synthesis of amino acids, enzymes and protoplasm. Second, through its conversion to ammonia, it can neutralize the volatile acids produced by fermentative bacteria, helping to maintain a stable operating pH. Other micronutrients are also required for some of the more complex enzymatic reactions of methanogens. For example cobalt, iron, nickel and sulfide are all crucial micronutrients to the methane forming bacteria [4].

Essential nutrients can quickly become toxic if concentrations become too high. For example, if nitrogen concentration increases too much, excessive ammonia can prove inhibitory and even toxic to methane-forming bacteria [4]. Other toxicity concerns include heavy metals, volatile acids, and hydrogen sulfide. It has been noted, however, that methanogenic bacteria have demonstrated certain adaptabilities to toxic environments. Many studies have shown that continuous digesters are often more resistant to toxic effects (through a slow increase in toxic compounds) as opposed to batch digesters (subject to shock loading) [5].

2.3 Reactor Design

There are many options for reactor configuration in anaerobic digestion. Possibilities range from plug flow to stirred tanks with recycle, and everything in between. One of the most important factors in efficient anaerobic digestion is ensuring that the solids have sufficient time to digest. The inherent problem with this, though, is that for a given flow rate, a digester with longer retention time will need to hold a larger volume. The Induced Bed Reactor (IBR) developed by Hansen *et al.* [11] overcomes this by effectively separating hydraulic retention time (HRT) from

solid retention time (SRT). This design allows water to pass through quickly, while retaining solids and biomass for maximum digestion. As this is the design employed at SDDS, the following sections will focus on the relevant design parameters for an efficient IBR system. For a better understanding, Fig. 1 has been included to show the design differences between an IBR and a continuous stirred tank reactor (CSTR). Details will be discussed in the flowing sections

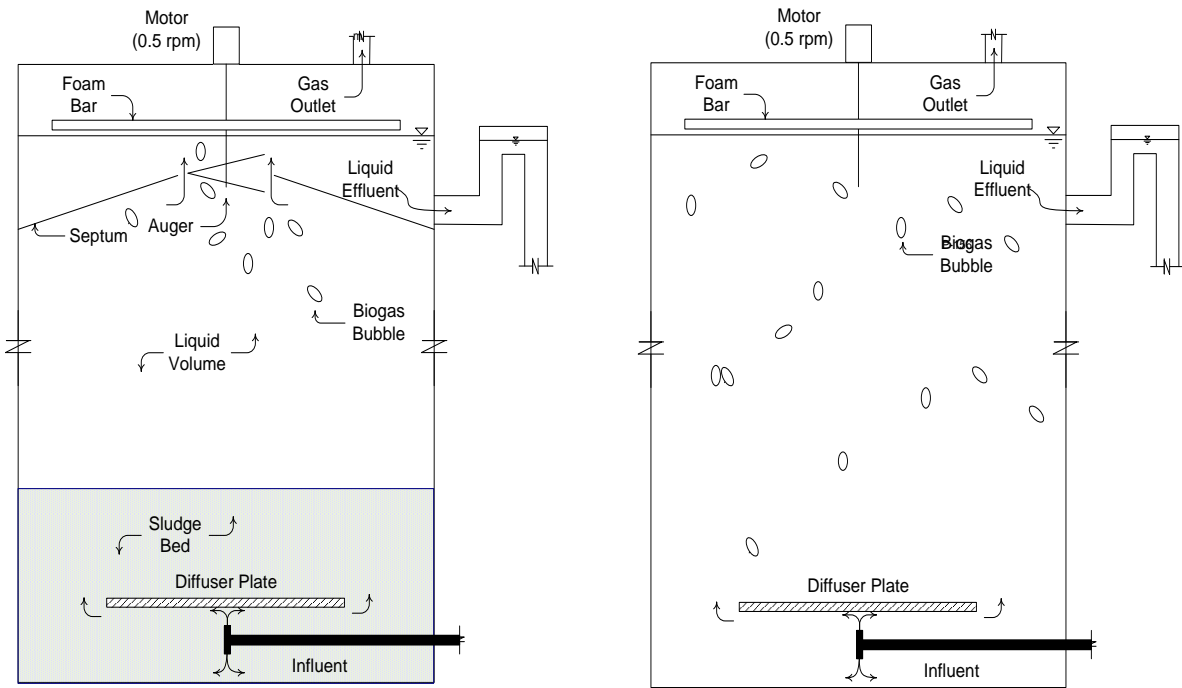

Fig. 1 - Cutaway of IBR (Left) and CSTR (Right) (Adapted from [1])

2.3.1 General Model

The IBR is a design developed and tested at Utah State University [11]. The primary design goal of the IBR is to accommodate high feed rates with high solid loading content. A baffle at the top of the tank acts as the separating mechanism of HRT and SRT. The IBR

encourages solid retention while allowing water to pass through much faster. The IBR accomplishes this with the induced bed, or baffle, installed at the top of the tank.

The IBR takes advantage of the biomass retention characteristics, while also allowing for the digestion of complex, high strength waste streams [1]. The auger at the top of the septum will limit the amount of solids able to reach the liquid effluent port. The following mass balance presents a simple starting point for the operational considerations, which follows the methods presented in a standard bioprocessing text [12]. It is important to note that a small concentration of digestion bacteria will enter the reactor with the influent substrate. Depending on how the substrate is handled prior to filling, anaerobic conditions may already exist to encourage cell growth. In general, this concentration may be small enough to negate, but it is still important to recognize. Due to imperfect cell retention, some bacteria will also manage to escape the reactor through the liquid effluent. The majority of the cell concentration comes from the growth that occurs within the reactor. Finally, because of the natural life cycle of cells, some cell mass will be lost within the reactor. This mass balance is represented here in Eq. (2).

$$\frac{dX}{dt} * V_R = FX_0 - FX + \mu_g XV_R - k_d XV_R \quad (2)$$

If the mass balance is run at steady state then $\frac{dX}{dt}$ can be considered 0. V_R is the reactor volume, F is the flow rate, X_0 is the influent cell concentration, X is the reactor cell concentration, μ_g is the cell growth rate and k_d is the endogenous metabolism rate.

Another mass balance approach considers the substrate, or feedstock, in the reactor. As in the previous mass balance, imperfect cell retention and incomplete biodegradability means the effluent also has a substrate concentration. As described earlier, some of the substrate is converted to bacteria cell mass and some is converted to product (methane and carbon dioxide primarily). This mass balance is presented in Eq. (3).

$$\frac{dS}{dt} * V_R = FS_0 - FS + \mu_g XV_R \frac{1}{Y_{X/S}} - q_p XV_R \frac{1}{Y_{P/S}} \quad (3)$$

If the digester is run at steady state then $\frac{dS}{dt}$ can be considered 0. V_R is the reactor volume, F is the flow rate, S_0 is the influent substrate concentration, S is the reactor substrate concentration, μ_g is the cell growth rate, $Y_{X/S}$ is the substrate to biomass yield, q_p is the rate of product formation and $Y_{P/S}$ is the substrate to product yield. Fig. 2 shows the control volume for the preceding mass balances.

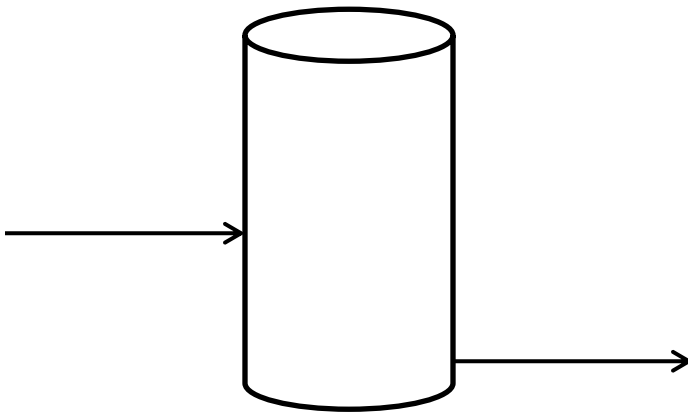

Fig. 2 - Digester Mass Balance

2.3.2 Residence Time

The amount of biomass digested is highly dependent on how long the solids remain in the system. Maximum conversion occurs after a residence of just about 10 days [5]. If the residence time was only considered as the HRT, the reactor would require a very large volume. The IBR, however, effectively separates HRT from SRT, allowing for a much smaller volume. The HRT can then be reduced well below the optimum 10 days required for digestion, while still

maintaining the SRT well above this limit. Studies on the IBR have shown that even with an HRT of 4 days, SRT values as high as 200 days can still be observed [1].

2.3.3 Productivity and Optimization

The productivity of the IBR can be evaluated using the adapted Contois kinetics model described in Equation (1). This model calculates specific methane production as a function of several system variables. First of all, B_0 is obtained as the ultimate methane yield of the given influent substrate. Values may range from 0.20 m³/gm to 0.5 m³/gm for different manure types [5]. The substrate concentration is merely a value obtained from the organic loading rate of the reactor, or the influent volatile solids. K and μ_m from Equation (1) can be calculated from Eq. (4) and (5), as presented by Gunnerson *et al.* [13].

$$V_s = \frac{B_0 * S_0}{HRT} * 1 - \frac{K}{HRT * \mu_m - 1 + K} \quad (1)$$

$$\mu_m = 0.013 * T - 0.129 \quad (4)$$

$$K = 0.8 + 0.0016 * e^{0.06 * S_0} \text{ for cattle manure} \quad (5)$$

While these equations hold true for some scenarios, it is often not exact. It is much more reliable to obtain these values from laboratory tests of expected substrate and flow conditions. Zemke *et al.* [3] conducted an experiment comparing this kinetic model to a full scale IBR. Results have shown that the model presented above cannot be applied to the IBR as is. A simple assumption was made in that study, however, to correct this. The design modification of the IBR effectively separates HRT from SRT. With this modification, the last term in Eq. (1) effectively drops to 0. Equation (6) can then accurately predict the biogas yield of an IBR digester

$$V_s = B_0 * \frac{S_0}{\theta} \quad (6)$$

While the above equation implies that specific gas yield is no longer dependent on temperature, Zemke *et al.* state that if the temperature drops enough to make μ_m small enough to undo the effects of a large SRT, then the last term of Eq. (1) can no longer be ignored [3].

DIGESTER SYSTEM

3.1 Sunderland System

The preceding fundamentals section has provided the background necessary for understanding the basics of a typical anaerobic digestion system. The SDDS follows these same principles. While some specific elements are different, the general theory still applies. The following sections highlight the operational specifics of this system.

The specific design of this digestion system is intended to minimize material handling by an operator. The design is mostly automated, needing only occasional maintenance and monitoring. Fig. 3 shows a simplified material flow diagram of this digester system. A more complex diagram has also been included as Appendix B (adapted from [9]).

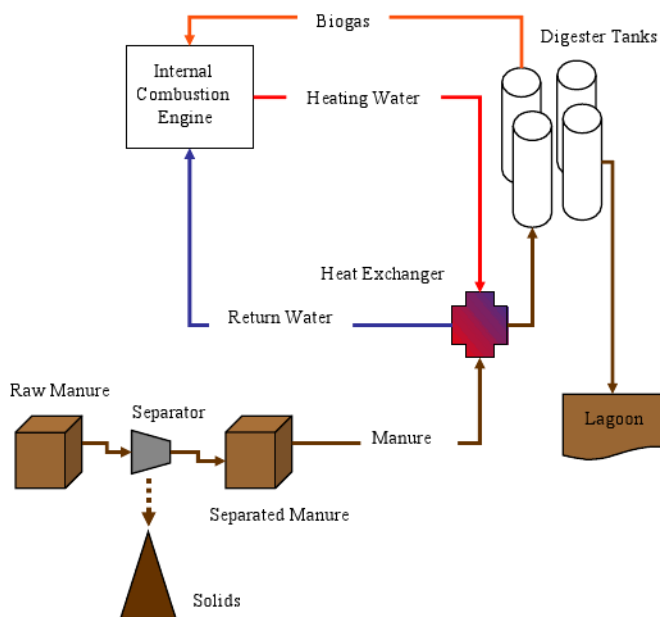

Fig. 3 - SDDS Process Flow (Adapted from [3]).

The collected manure is first fed to a hydrating and mixing pit where it can be homogenized. From this pit, it is fed through a separator to remove materials that may add to clogging of the plumbing. From here, the feedstock is fed to a second holding pit. Ferric Chloride is added in this pit to help reduce the amount of hydrogen sulfide gas produced in the digesters. Before being fed to the tanks, the influent is heated through a series of heat exchangers. While not shown in Fig. 3 because it is a simplified schematic, the first heat exchanger is a waste heat recovery (WHR) system that collects heat from the tank effluent and adds the heat to the influent. The next heat exchanger heats the influent up to the desired temperature by collecting heat from the engine-generator as well as additional boilers if needed. The heated manure stream (a slurry) is then fed to the tanks, where the biomass is broken down and converted to biogas. The biogas that comes from the digester is fed to a biogas conditioner. The conditioned biogas can then be fed to an engine-generator, producing electricity. Another option for the conditioned biogas is to use it for powering boilers. If, for any reason, the gas cannot be fed safely to the engine-generator or boiler, then it is diverted to a flare and burned off in the atmosphere to avoid any hazardous accumulation of the toxic gas.

3.2 System Environment and Capacity

The Sunderland Dairy is located in Chester, Utah. Housing approximately 450 cattle, the dairy produces between 35 and 60 m³ per day of manure slurry [3]. This slurry, after the preparation stages described below, is then fed to the digesters. There are four digestion tanks total, each one with a 120 m³ volume. Being in central Utah, the temperatures can undergo severe seasonal and diurnal fluctuations. As a result, the digesters are enclosed in an insulated building to minimize the tank heat loss to the environment. In addition to housing the tanks, a separate room in the building is used to house the engine-generator and other equipment. The following

sections will describe the specific components involved in the total digester system. For ease of understanding, the components are separated into three subsections of upstream, digestion and downstream.

3.3 Upstream

The tasks upstream of the digester are mainly concerned with preparing the feedstock for digestion. The first step is to prepare the feedstock to the correct slurry composition for optimum digestion. Next, the feedstock is heated to the appropriate temperature to maintain mesophilic digestion. The specific methods and equipment for these steps are presented in the following sections.

3.3.1 *Hydrating*

The manure is collected using a tractor mounted with a scraping arm. The manure is scraped into a trench that carries the mixture to the first holding pit. This pit is used as the feed for the separator. To optimize digestion, the feedstock must be homogenized to a slurry with approximately 6% solids. This concentration is achieved through use of the separator and grinder. First, the separator removes the larger particles that may cause plugging. Next, the chopper breaks the remaining particles down into smaller pieces. Because solids will only digest at the surface area exposed to the bacteria, smaller particles yield better digestion efficiencies. The next step in preparing the feedstock for optimum digestion and gas production is through the addition of ferric chloride [8]. Addition of this chemical has been shown to reduce the amount of hydrogen sulfide gas produced from the digestion of cattle waste [8]. A second holding and mixing pit is used to add the chloride.

Once the feedstock has been prepared in the holding and mixing pits, it is pumped into the digester building for heating. As a side note, this particular Ferric chloride solution, while

effective, has proven to be an overly expensive solution to H₂S mitigation. As a result, other techniques are being explored for application at SDDS.

3.3.2 Heating

As discussed in the fundamentals section, anaerobic bacteria have optimum temperature ranges for gas productivity. For economic reasons, mesophilic is the range desired for this project. The average tank temperature is to be maintained near 35 °C. The methods for adding this heat to the digester influent are presented in the following sections. Specific details of the heat exchanger design and efficiencies are presented in later sections.

The first step to heating the influent is WHR from the digester effluent. A simple tube in tube heat exchanger was installed to transfer heat from the effluent manure to the influent manure. Due to a design flaw, however, the outer pipe would clog with suspended solids [8]. To overcome this, the heat exchanger was retrofitted by splitting it in half and employing a water jacket to transfer the heat from the warm effluent to the cool influent. The warm effluent to water section is operated as a counter flow exchanger, while the water to cool influent section is operated as a parallel flow exchanger. Each exchanger is 14 meters long with 40 mm nominal diameter piping for the center tube and 50 mm piping for the annulus. This WHR only provides a small amount of the necessary heat. The main heat exchanger, described next, shows how the majority of heat is added to the influent slurry.

The main heat exchanger is a shell and tube (ST) design that transfers heat from a hot water source to the digester influent. From the outside, the heat exchanger just looks like a large cylinder, while inside the water is circulated across a series of manure pipes. This exchanger is constructed as a multiple pass exchanger that is 7 meters long. The shell is 325 mm diameter and contains approximately 60 meters of 50 mm pipe. The water is heated by circulating it across

several heat sources. The primary heat source for this water loop comes from the waste heat off the engine-generator that burns the biogas (to be discussed later). Heat is added to the water from the engine-generator in two ways. First, the water is run through a separate heat exchanger to collect heat from the exhaust of the internal combustion engine. Next, the water is circulated through the coolant system of the engine block. If the engine is not able to provide enough, there are additional boilers that can provide the needed heat.

A critical design for heating efficiency provides what is known as thermal capacitance. Two standard 0.45 m³ water heater tanks were installed in a recent retrofitting project to provide thermal storage for the system. This helps to stabilize the temperature of the heat loop and keep it from fluctuating with the temperature of the inlet manure slurry.

3.4 Digester

As mentioned before, there are four digester tanks, each with a volume of 120 m³. They are approximately 10 meters tall and are constructed from 6.5 mm thick steel. The digester tanks have a variety of components associated with them to ensure uninhibited operation. The IBR is designed to retain solids under the septum. The septum auger is used for this purpose. In the event of plugging, the IBR also has several pressure relief features to prevent any major damage to the tanks and system.

3.4.1 *Flow and Operation*

At its original commissioning, the SDDS was equipped with four standard IBR digesters. Since then, USU has converted two of them into CSTR operation by drilling large holes in the septum as part of an ongoing experiment [2-3, 7]. The study was designed to show the performance differences between the IBR and (CSTR) configurations. Future projects may convert the CSTR's back into IBR's by simply plugging the extra septum holes. To aid in septum

performance, and to prevent plugging, the IBR septum has been equipped with a flexible cap to allow completely aerated solids to pass through without causing a plug [8].

Each tank has one main inlet with several outlets. The inlet is located at the bottom of each tank. As there is only one heated feed stream, each of the four tanks is alternately fed from a common stream to simulate continuously fed digesters. The feeding is controlled with automatic actuated valves linked to the controls system. Typical tank filling will cycle on an hourly basis, feeding each tank for 15 minutes at an average of 2.3 m³/hr (equivalent to 10 gpm). One of the three outlets is also located at the bottom of the tank. This outlet is designed to remove settled solid particles from the bottoms of the tanks while the digesters are still in operation. There are two outlets at the top of each tank as well. The first allows the gas to escape, while maintaining a positive pressure of 30.5 cm H₂O. The other outlet is a fluid port located near the top of the tank. This allows for a continuous flow through each digester to maintain bacterial activity.

3.4.2 External Systems

The four tanks are housed in a large steel building to protect them from the outside environment and reduce heat losses. The building is 15m by 18m and is 13m tall at its highest point. The building has several doors, including large bay doors to simplify equipment maintenance. The walls of the building are lined with 7.6 cm fiberglass insulation to improve heat retention. The building is equipped with a separate room to house the engine-generator, boilers, and gas conditioning equipment.

Each tank is equipped with several safety features to prevent any hazards or serious damage. A common failure of digesters is clogging in the feed lines or within the tank. Unchecked, this can lead to pump failure or a rupture in the tanks or plumbing. The first safety mechanism is a septum bypass mounted on the side of each tank. In the event of a septum hole

becoming plugged, the tank feed will be forced through the bypass, rather than backing up in the tank and potentially frying the feed pump.

While the septum bypass provides a moderate safe guard against failure, there is still a chance that this line could plug as well. To prevent any tank ruptures or permanent damage, each tank is equipped with a burst plate on the top surface. If a digester were to become completely clogged with an increasing internal pressure from gas production, the burst plate will rupture to release the growing pressure. While this may cause a bit of a mess in the building, the damage will not be permanent and will only require a replacement burst disk to return to operational status.

The third safety feature on each tank is a gas pressure release valve. As a side measure to prevent burst disk rupture, the gas pressure relief valve is designed to maintain the tank pressure within safe operating limits. Once the valve experiences too high of a pressure, excess biogas will be diverted to the outside flare (discussed later) for safe disposal.

3.5 Downstream

As previously mentioned, there are two types of effluent streams from the digester, each one requiring their own specific handling prior to use, or ultimate disposal. The first effluent type is for the solid and liquid waste (the digested slurry), while the second is the produced biogas.

3.5.1 *Solid and Liquid Waste*

There are many options for handling solid and liquid digester effluent. The method currently being used, however, is part of the system used prior to the digester installation. All waste used to be handled by feeding it to a settling pond adjacent to the dairy. The waste would be fed to this pond to sit and decompose via natural processes, creating a large environmental issue from odor and gas release. While waste is still disposed of in this pond, the odor concern is

far less serious now as most degradable solids have been converted to methane within the tanks. Another option, currently not employed at SDDS, is to dry and bag the solid wastes as they can easily be sold as a high grade fertilizer for various agricultural applications.

3.5.2 *Gas*

The biogas that leaves the digesters is primarily methane, about 70% [2]. The other major component is carbon dioxide, about 30%. There are also traces of moisture and hydrogen sulfide in the gas stream. Both of these have a negative effect on the engine-generator efficiency and longevity. Before the gas can be utilized for system energy, it is best to first condition it [5]. There are several options for removing hydrogen sulfide from the gas stream. Many options are currently being investigated at USU. There are no solutions currently installed, other than the initial addition of ferric chloride to reduce the amount of hydrogen sulfide produced.

The next conditioning option is to remove as much moisture from the gas stream as possible. The biogas coming from the tanks will be completely saturated with moisture. This, in turn, leads to lower fuel efficiency for the engine-generator. A simple way to remove this moisture from the gas stream is to condense it by sending the gas through a chiller system. Removing the moisture from the biogas significantly increases the heating value [14]. The installed condensation system was designed as part of a senior design project from USU. The condensate from this system is fed directly out to the waste lagoon along with the digester effluent. Despite its recent installation, the chiller is not currently used to condition the gas stream.

Once the gas has been properly conditioned, it is ready to use in an engine-generator or biogas boilers. The engine-generator used at SDDS is a modified Chevy 454 Big Block Engine capable of running on this mixture of methane and carbon dioxide. There are two elements to the

heat recovery from the engine. First, there is a heat exchanger, a 1 meter long single-pass ST exchanger, which transfers heat from the exhaust to the water loop. Secondly, this water stream is circulated through the coolant system of the engine to remove heat from the engine block.

The final element in the gas handling system is a safety flare. The flare is used in the event that the produced biogas cannot be safely used, or if the biogas production rate ever exceeds the rate at which it can be used. The gas is only diverted to the flare if the pressure between the tank and the engine-generator exceeds the setting of the pressure release valve discussed above. This flare assembly is where the gas can be ignited and safely combusted. Housed inside the pilot tube is an orifice plate that reduces the gas flow to an ignitable velocity and fuel/air mixture. This flow is ignited by an electric spark which arcs between two tungsten welding electrodes.

3.6 Controls and Monitoring

To minimize operator responsibilities, the system is run from a centralized control unit that has a simple touch screen interface. Not only does this interface collect all data from the system instrumentation, it also allows the operator to adjust things like target temperature and flow rates as needed. The data acquisition system collects all relevant data to monitor the system performance. This includes temperatures, digester feed rates (and thus retention times), gas production rates and digester pH levels.

PERFORMANCE ANALYSIS

4.1 Performance Analysis

As discussed in the problem statement, the main goal of this study is to improve the heat utilization of the SDDS. Current operation is limited to the warmer months of the year, if the temperature drops below acceptable levels the bacteria cannot adequately convert the biomass into methane. The lowered operating temperatures result in a decreased biogas production, and subsequently lowered heat availability for maintaining temperatures. Before improvements can be identified, the system needs to be accurately depicted both empirically and with a dynamic computer model that accounts for year round weather effects.

Each system element is first analyzed and represented empirically to identify steady state characteristics. The main elements considered are heat transfer coefficients of the building and tanks, as well as effectiveness of each heat exchanger in the system. The empirical analysis of each major component is discussed in Appendix A. The steady state analysis is then used to develop a transient model of the digester system. The effects of weather fluctuations are difficult to predict with steady state analysis, but a modeling program such as TRNSYS is capable of handling the iterative calculations required to predict system performance. A detailed discussion of the developed TRNSYS model and the included components is presented in the following section, as well as a more in depth discussion in Appendix C.

The system is currently operational from mid-April to early-November, according to the system operator. The winter months are too cold to keep the system above an acceptable temperature with the current heat utilization techniques. The completed TRNSYS model was used to calculate the expected tank temperatures over the course of a full year. The data from this simulation is shown in Fig. 4.

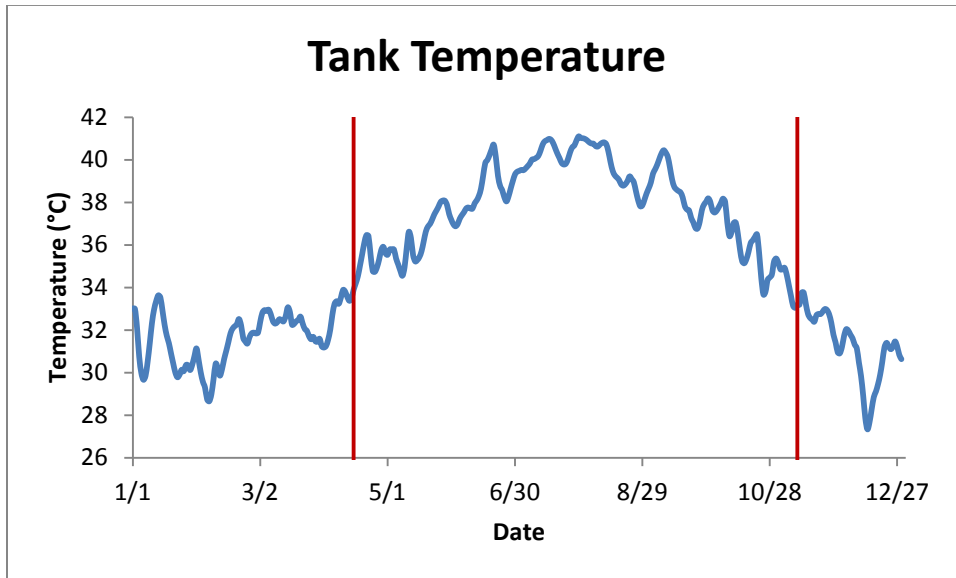

Fig. 4 - Tank Temperatures

The operator shuts down the system once the tanks no longer show temperatures above 33 °C, represented by the vertical lines in the above figure. This validates the computer model, as the simulation predicts a total of just over 7 months (mid-April to mid-November) that the digester tanks remain above 33 °C using only waste heat recovery and heat from the engine-generator operating on produced biogas.

4.2 TRNSYS Model Details

The TRNSYS library provides many precoded components which are used in the development of this model (e.g. heat exchangers, thermal storage tanks, engine-generators, etc.). Each of these components are coded using proven scientific equations and adjustable user inputs and parameters to accurately model a real world counterpart. As mentioned before, a transient system such as the SDDS requires a large number of iterations in order to calculate system performance and temperatures as a function of not only the environmental conditions but also

each system component. The processing power of TRNSYS allows a full year to be simulated in only a matter of seconds. This section will describe some of the technical aspects of the major components.

One of the first components of interest is the insulated building in which the digester tanks are stored. This building acts as a buffer between the heated tanks and the fluctuating environment. The change in temperature of the building is calculated as a function of the buildings loss coefficient, the buildings heat capacitance, the outdoor temperature and the sensible energy gains within the building (i.e., heat gains from the tanks or operational equipment). In order to calculate the energy gain of the building from the heated tanks, a similar approach is needed to show the heat loss of the digester tanks. This heat loss is calculated as a function of the tanks heat loss coefficient, the temperature of the tank fluid and the temperature of the building air. Examples of these equations can be found in the appendices of this thesis, as well as most engineering texts and the TRNSY documentation [10, 15-16].

The next major components of interest are the heat exchangers used within the SDDS. While there are several different types of exchangers used, the approach of TRNSYS is fairly similar for both tube in tube and shell and tube exchangers. Each component calculates outlet temperatures based on the combination of input temperatures and parameters such as exchanger design, heat transfer coefficient, fluid flow rates and heat capacities. The iterative approach of TRNSYS means that transient outlet temperatures can be easily calculated as a function of the varying inlet conditions (mainly dictated by environmental temperatures and gas production).

This section provides a brief insight to the requirements for some of the major components used in this model. There are many other components used, but their operation is equally straight forward. Various components used include a weather data reader, temperature controllers, an engine-generator, and even modifiable equation editors to simulate specific phenomena like

biogas production. Detailed descriptions and equations for all relevant components are included in Appendix C.

4.3 System Heating Design and Operation

There are many elements required to add heat to the digesters. As discussed in 3.3.2, heat is generated from a biogas engine-generator. Transferring this heat to the tanks and inlet manure stream is done with several heat exchangers and a thermal storage loop. Figure 5 shows the specific layout of these elements and how they are installed at SDDS. The dashed lines represent the flow of the manure slurry, while the solid lines represent water loops that are used to help transfer heat to the manure. The heat exchangers shown at the very top (labeled Waste Heat A and B) represent the WHR exchanger that uses the already heated digester effluent to initially heat the manure slurry coming from the outdoor storage pits. As previously mentioned, a design flaw in this heat exchanger requires water to be used as an intermediary to prevent plugging.

After the WHR unit, the manure slurry is fed through the primary heat exchanger (labeled Main Heat Exchanger) to raise the slurry up to mesophilic temperatures. The other side of this heat exchanger is where the heat for this system is generated and collected. As shown in the image, there are many different elements capable of providing heat. The first heat source collects waste heat from the installed engine-generator, from both the engine exhaust and the coolant loop across the engine block. In the event of engine failure or required maintenance, the biogas from the digesters can be diverted to one or both of the included biogas boilers. An optional bypass can also collect heat from a natural gas fired boiler. The thermal storage component helps with heat exchanger performance and system stability. The following sections discuss the detailed design and use of the heat exchangers and produced biogas.

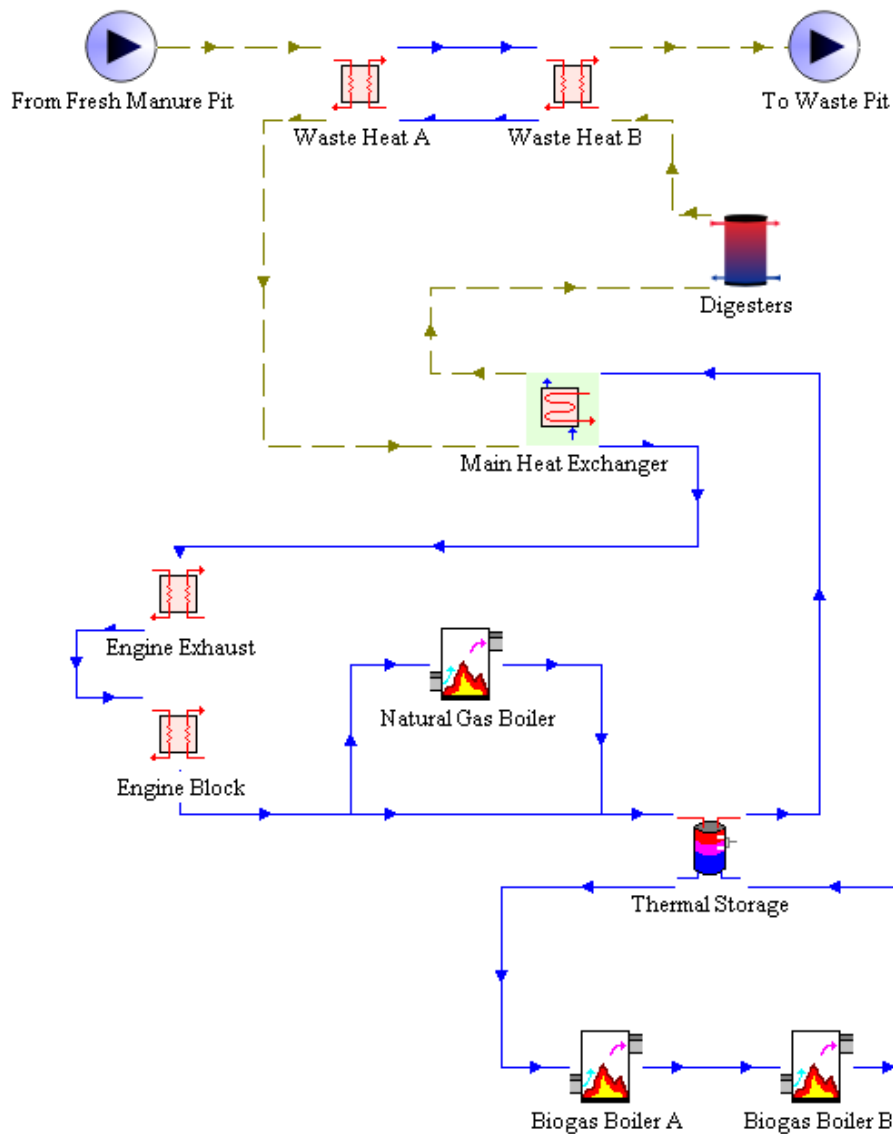

Fig. 5 - SDDS Heating Schematic

4.3.1 Waste Heat Recovery

WHR is invaluable in reducing the amount of energy needed in a thermal fluid system such as this. By collecting heat from the fluid outlet and adding it to the fluid inlet, the system

potential can be dramatically increased. The WHR unit currently installed at SDDS is a standard tube in tube heat exchanger, examples of which can be found in common engineering texts [15-16]. The manure slurry is the tube fluid while water is the annulus fluid. This heat exchanger was originally intended to transfer heat directly from the effluent manure slurry to the influent; however the solids content of the slurry would regularly block flow through the annulus. To overcome this problem, the heat exchanger was split in half to use water as an intermediary to avoid annulus blockage. Following methods presented in current engineering texts [16], and presented in detail as part of Appendix A, the overall heat transfer coefficient of each half of this exchanger is calculated to be used in the TRNSYS model to describe the heat exchanger operation. Using two heat exchangers with water as the intermediary at steady state results in a 2-3 °C temperature increase for the inlet manure slurry.

4.3.2 *Primary Heat Loop*

There are two heat exchangers of interest in the primary heat loop. The first is a single pass ST heat exchanger that is used to transfer heat from the engine-generator exhaust to the water of the heat loop. The other heat exchanger is a double pass ST heat exchanger that transfers heat from the water to the inlet manure slurry. As with the tube in tube, examples of these types of ST exchangers can be found in standard engineering texts [15-16].

The exhaust exchanger uses water as the tube fluid and the engine exhaust as the shell fluid. The water enters an end channel and is diverted down a sheet of nineteen 25 mm tubes. The shell fluid enters through a separate inlet and is directed across the tubes to heat the water. While most engineering texts recommend the use of baffles for the shell fluid, discussions with the engineer responsible for the design of this specific exchanger indicates that no baffles were

used. Using methods presented in Appendix A, the heat transfer coefficient of this exchanger is calculated to provide the necessary TRNSYS input.

The main heat exchanger is also a ST configuration, but it is much larger and has a slightly different fluid path than the exhaust exchanger. Unlike the exhaust heat exchanger, the main ST is designed as a multiple pass exchanger. The tube fluid (the inlet manure slurry) undergoes multiple passes through the shell. To simplify the modeling and empirical analysis, a double pass configuration is assumed. The shell fluid, being water coming from the thermal storage and heat sources, passes over the tubes. The design engineer said that there is only one baffle in the installed exchanger. The overall heat transfer coefficient for a multiple pass ST exchanger of this specific design is calculated (shown in Appendix A) to provide the TRNSYS input. For steady state operation, this causes the manure slurry to increase approximately 25 °C, bringing it up to an adequate temperature for the anaerobic bacteria to perform the desired conversion of biomass into biogas.

4.4 Biogas Production and Use

As presented in 3.5.2, there are many different options for use of the biogas. The biogas combustion is in fact the main (and usually only) source of heat for the digester system. A simple schematic of how the gas may be used is presented in Fig. 6. The solid lines represent gas flow, while the dashed lines represent the resulting heat flow. As the gas leaves the digester, it is routed through a biogas chiller. As the gas leaves the digester, it is fully saturated with moisture. By cooling the biogas, the entrapped moisture is condensed out, thus increasing the heating value [14]. Once the biogas has passed through the chiller, it can either be used in the engine-generator or the biogas boilers. A supplemental boiler that runs on natural gas is present in the event that biogas cannot be used or does not provide sufficient heat. While all of these items are installed,

the operator currently sends the biogas directly to the engine-generator, without utilizing the chiller or the boilers. Not shown in the above schematic is the alternate safety outlet of the biogas flare. This bypass is located between the digesters and the chiller.

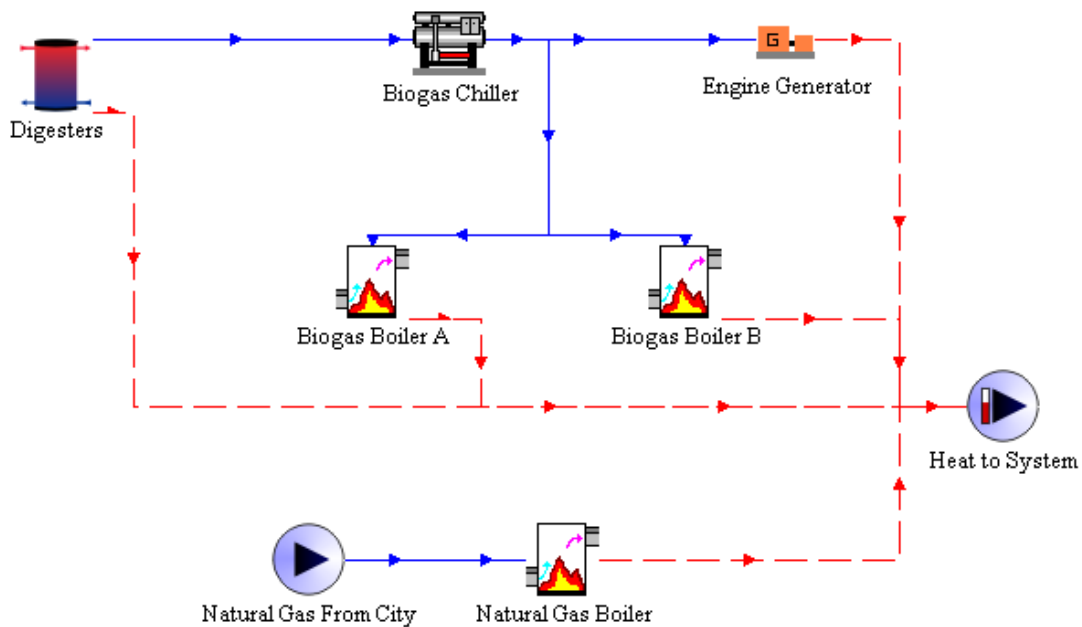

Fig. 6 - Biogas Use

Recalling from 3.4.1, two of the tanks are IBR construction while the other two are CSTR. Studies by Zemke *et al.* [3] have produced useful data showing the year round biogas production of SDDS, represented in Fig. 7. The darker line represents the specific biogas production rate (m^3 gas per m^3 of reactor volume per day, or day^{-1}) of the IBR tanks, while the lighter line represents that of the CSTR tanks (labeled as Control). Clearly the CSTR reactors are much more sensitive at lower temperatures, but both reactor designs suffer in the winter months. The implications of this are discussed in the following section.

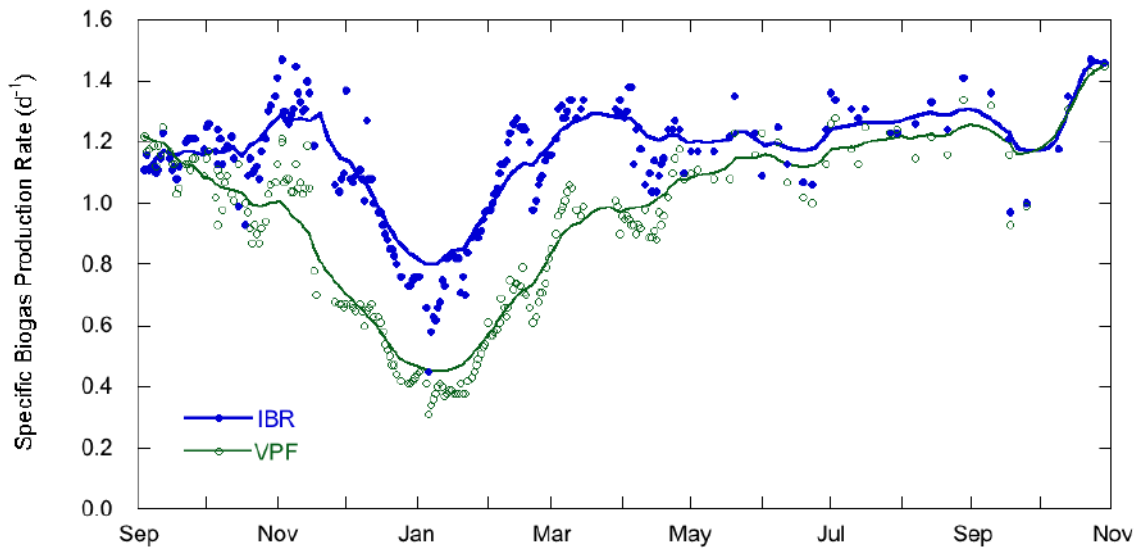

Fig. 7 – Biogas Production (Adapted from [3])

4.5 Simulation Inputs

In order for the TRNSYS simulation to accurately predict the SDDS operation, certain inputs are needed. The following tables describe the major inputs provided to the simulation model. Similar to the section describing the Digester System, these inputs are separated into the three categories of upstream, digester and downstream. The inputs regarding the upstream portion are shown in Table 1. The assumption is made that the manure slurry properties are similar to water, especially because of the low flow rates and low solids content. The strength of the slurry content is assumed constant by taking average values from Zemke et al. The thermal properties of the slurry/water are taken from an engineering text, the ranges indicate that several values were used according to the appropriate temperatures for each input (e.g. manure pit, heat exchangers, heat loop). The coefficients for the heat exchangers were calculated using methods presented in

Appendix A. The heat loop flow rate was estimated in those calculations to force temperature change values of the empirical analysis to match those measured in the real world system. The thermal storage tanks are assumed similar to the digester tanks for the heat loss coefficient, which is calculated in Appendix A.

Table 1 - Upstream TRNSYS Inputs

Upstream System Inputs		
Water/Slurry Properties	B_0	0.35 m ³ biogas kg ⁻¹ VS fed [3]
	S_0	32.4 kg VS m ⁻³ influent [8]
	C_p	4.178-4.19 kJ/(kg*K) [16]
	k_f	2.088-2.261 kJ/(hr*m*K) [16]
Heat Exchangers	WHR Coefficient	2536 kJ/(hr*K)
	ST HX Coefficient	9307 kJ/(hr*K)
	Exhaust HX Coefficient	176 kJ/(hr*K)
	Heat Loop Flowrate	9085 kg/hr
Thermal Storage	Thermal Storage Volume	0.9m ³
	Heat Loss Coefficient	6.715 kJ/(hr*m ² *K)

Table 2 presents the inputs regarding the digester system portion of the TRNSYS model. The digester HRT is taken as an average value to simulate a target flow rate of 55 m³/day (10 gpm). While this value is not constant in the real world system, this assumption will suffice for this study. Weather and building properties are defined to determine the heat loss rates from the tanks. The weather patterns are assumed comparable to Cedar City Utah, so typical

meteorological year (TMY) data from there is provided. The building size is estimated, and the heat loss coefficient is calculated according to Appendix A. The temperature limits are selected to mimic the operator's involvement in keeping the tanks from overheating.

Table 2 - Digester TRNSYS Inputs

Digester System TRNSYS Inputs		
Tank Properties	Digester Volume	120m ³ [8]
	Heat Loss Coefficient	6.715 kJ/(hr*m ² *K)
	Digester HRT	8.8 days
Building Properties	Weather	TMY from Cedar City
	Surface Area	1171m ²
	Volume	3811m ³
	Capacitance	4451kJ/K
	Heat Loss Coefficient	1.201kJ/(hr*m ² *K)
	Air Density	1.16 kg/m ³ [16]
Temperature Limits	Exhaust Bypass On	Above 42 °C
	Exhaust Bypass Off	Below 40 °C
	Engine Heat Dump On	Above 42 °C
	Engine Heat Dump Off	Below 40 °C

Table 3 presents the inputs downstream of the digester system. The biogas properties are obtained from various sources. The engine performance follows the standard rule of thirds (of the available incoming energy, 1/3 is converted to power, 1/3 is converted to exhaust heat and 1/3 is

converted to block heat). To reconcile building temperatures, a portion of both exhaust and block heat is transferred to the surrounding environment (20% of each). The properties of the exhaust gas are calculated using stoichiometry, as shown in Appendix A.

Table 3 - Downstream TRNSYS Inputs

Downstream System Inputs		
Biogas Properties	Density	0.982 – 1.02 kg/m ³ [5, 14]
	Specific Heat	1.22 kJ/(kg*K) [5]
	LHV	21603 kJ/m ³ [14]
Engine Performance	Power Efficiency	33% [17]
	Waste Heat (calculated through TRNSYS)	40% to Block
		40% to Exhaust
		20% loss to Building
Exhaust Properties	Flowrate	8.9 kg exh/kg biogas
	Specific Heat	1.18 kJ/(kg*K) [16]

4.6 TRNSYS Model Validation

The results of this study rely heavily on the assumption that TRNSYS can be used to predict performance using design parameters and environmental conditions of SDDS. It is important, therefore, to confirm that the results from the simulation match data from the real world system. Operational temperatures provide the most insight into how well the model matches SDDS. Also, data from actual biogas production can be compared to theoretical production based on transient tank temperatures and other assumptions.

4.6.1 *Temperature*

TRNSYS components are developed using scientific principles and the appropriate governing equations. Proven text book methods can be used to predict appropriate equipment parameters, and the simulation can be used to show how the combination of all these components will respond in a certain environment. Data from past Sunderland projects are used to compare tank temperatures to the model output. The comparison periods of the following analyses only cover June through August due to a lack of reliable data from the rest of the year. Because of the difficulties in repeating weather patterns and operator maintenance issues, an exact match is not guaranteed. Fig. 8, however, shows that, despite some minor differences, general similarities and ranges can still be confirmed. The solid curves represent the TRNSYS simulation output while the dotted lines show the collected data. The top two lines (tank temperatures) show a very close agreement. The bottom lines show the temperature of the outdoor holding pit, which is used to feed the digester system. The major source of the differences between the generated simulation and the measured data is attributed to weather patterns. While the measured data was subject to the weather experienced from June to August of 2009, TRNSYS data is a function of the TMY data for those months. TMY is generated from an analysis of 30 years of data that most accurately represents a typical year. As a result, temperature swings of a certain year will have slightly different patterns from a set of TMY data, but will still show similar ranges and averages. As seen in the above image, the manure temperature (coming from the outdoor manure pits) for both the real data and generated TRNSYS data falls within the 15 to 25 °C range. The patterns in tank temperature differences (TRNSYS vs. real data) clearly mimic the differences in manure temperatures (which are much more dependent on weather fluctuations).

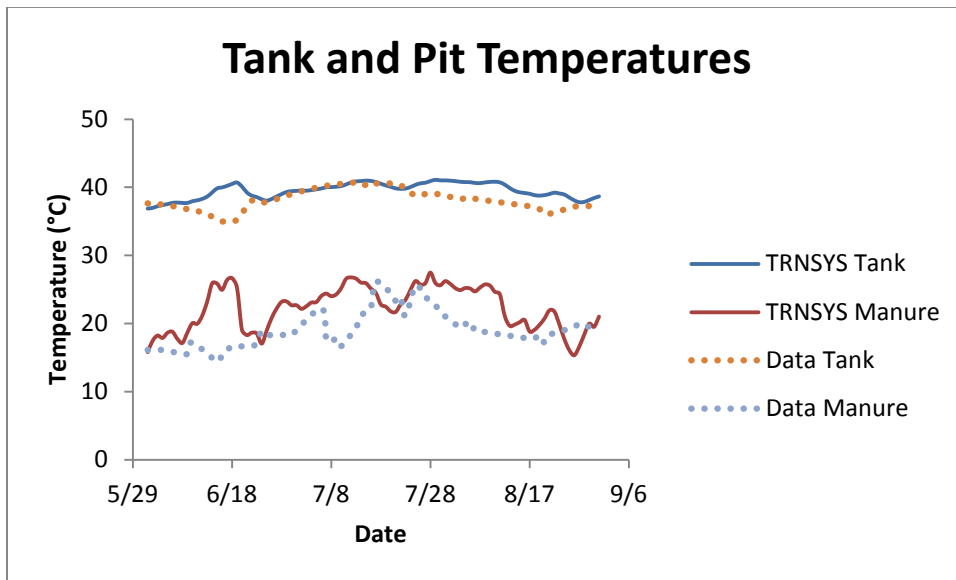

Fig. 8 – Tank and Pit Temperature Comparison

Another value for model confirmation is the building temperature. TRNSYS is capable of modeling a building enclosure that not only accounts for heat loss to the surrounding environment, but also the sensible energy gain from the tanks and heating equipment within the building. Figure 9 shows the comparison between collected data and simulation output. Again, the solid curve shows TRNSYS output while the dotted line shows collected data. While the collected data set matches the average trend of the simulation, many more short term fluctuations are seen in the data. This is because daily operation of the digester system requires the bay doors of the building to sometimes be opened and closed, thus exposing the room to outdoor conditions. This may also play a small role in the differences seen between data and TRNSYS values for the tank temperatures seen in Fig. 8. While these differences are unavoidable, the purpose of this study is to show relative effects on performance changes rather than absolute values for given operation. As a result, these discrepancies are acceptable.

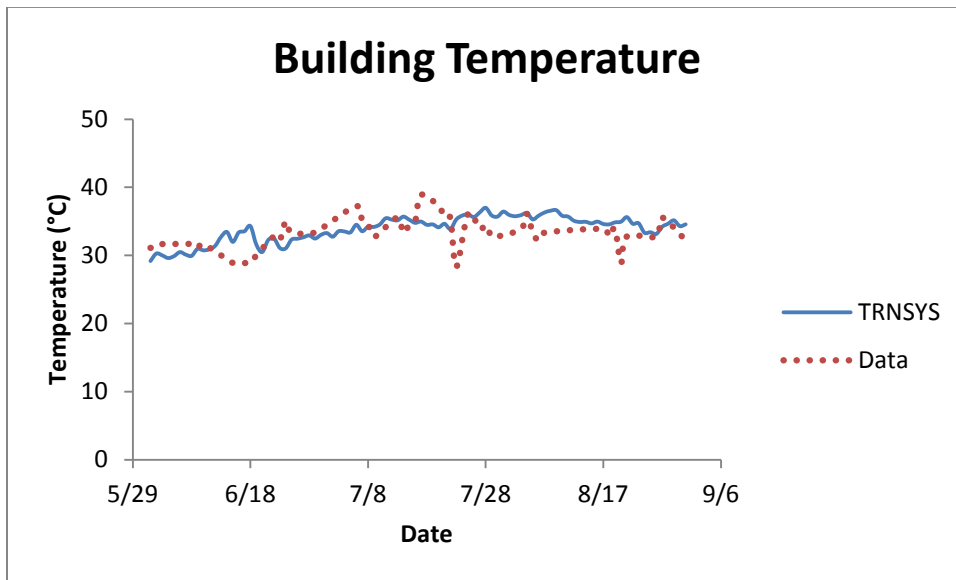

Fig. 9 - Building Temperature

4.6.2 Heat Exchanger Efficiencies

While the overall temperature comparisons provide a certain amount of confirmation, it is still important to verify individual component performance. The main components of interest are the three installed heat exchangers (WHR, the main ST and the exhaust exchanger). Steady state measurements with a handheld thermocouple give a decent understanding on the temperature changes of inlet and outlet flows. Temperature and exhaust flow rates for the engine are estimated from stoichiometry calculations and a general understanding of internal combustion engines.

These rough measurements provide a basis for modifying the assumptions to help calculate exchanger efficiencies that closely match real world performance. While the measurements collected with the handheld thermocouple device are not extremely reliable (e.g. air flow in the building, different pipe materials) a general understanding of temperature differences over each heat exchanger was still achieved. Again, this method would not be

acceptable for a study concerned with absolute values of system performance, but because the focus here is on relative results from equipment modification it will suffice.

4.6.3 *Biogas Production*

The next area for model confirmation is biogas production. Recalling the discussion in 2.3.3, the two modifiable elements in controlling gas production rates are temperature and HRT (volatile solids content and ultimate biogas yield are constants defined by the composition of the cattle waste). Because both tank designs (CSTR and IBR) suffer from lower temperatures in the winter, biogas production is representative of this.

Using the equations for biogas production developed in 2.3.3 and the developed TRNSYS model, biogas production is predicted. A graph comparing the theoretical production to the actual gas output is presented as Fig. 10. There is clearly a large disagreement in the winter months. This is for several reasons. First of all, while the real data was being collected, the digesters were forced to shut down for a period in early January due to freezing in the outdoor manure pits [3]. Even for the months when the pits are not completely frozen, the manure slurry still has some ice content. The ice being fed through the exchangers into the tank seriously reduce the temperatures. Finally, the modeled gas production is partly based on the assumption posited by Zemke *et al.* [3] that IBR productivity can ignore temperature influences. Clearly the temperatures dropped to a level where this assumption no longer holds, hindering methanogenic growth rates. Despite these disagreements, the averages of each set still fall within 15% of each other (0.975/day for the data set and 1.092/day for the theoretical), thus confirming the reliability of the already published approach [3].

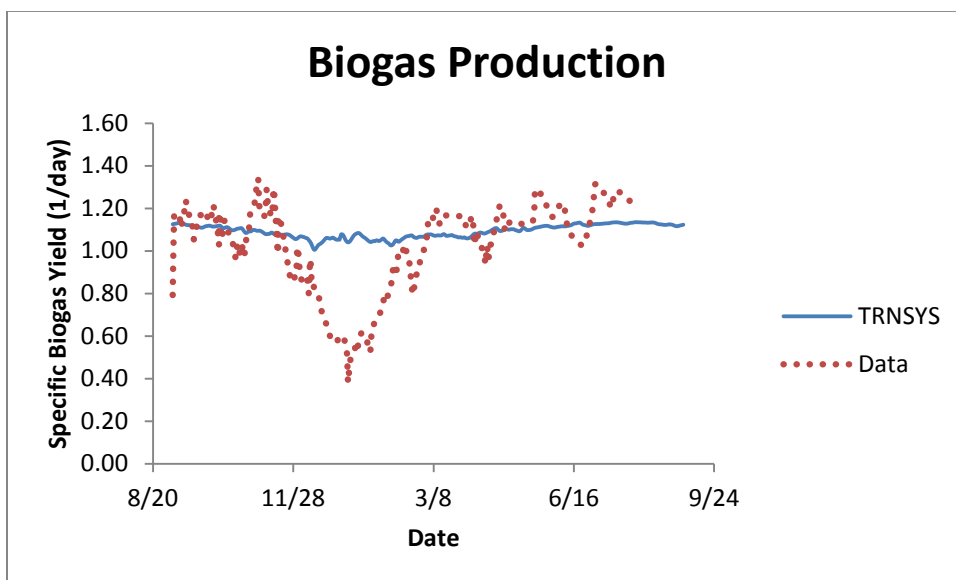

Fig. 10 - Biogas Production from TRNSYS

POTENTIAL SYSTEM IMPROVEMENTS

5.1 Potential System Improvements

After an in depth study of the current system, the goal is to investigate potential changes to achieve year round operation. The focus of this section is thus how best to utilize the available heat for maintaining mesophilic temperatures, especially during the winter months. There are four main areas where system improvements are considered. These areas are WHR, the efficiency of the main ST heat exchanger, the efficiency of the exhaust heat exchanger, and finally biogas utilization. After discussing the possible improvements to each of these individual areas, the potential system performance from various combinations of the proposed improvements is discussed. To quantify each change, the TRNSYS model is used to simulate a full year of operation, and each scenario is assessed for how many days of the year the digesters can be maintained above 33 °C.

5.2 Waste Heat Recovery

The biggest design improvement that can be made to SDDS is to fix the WHR unit [2]. Redesigning the WHR unit to be a manure to manure exchanger (as opposed to the current manure to water to manure format) will greatly increase the amount of heat that can be added to the slurry inlet. The needed design change to make this feasible is to enlarge the annulus, to overcome the plugging issue of the current unit. The current unit transfers heat from the digested manure to water in a counter flow tube-in-tube exchanger, and then transfers the heat from the water to the new slurry in a parallel flow tube-in-tube exchanger of equal dimensions.

The optimum configuration for the redesign of this tube-in-tube exchanger is counter flow (as opposed to parallel flow) [16]. A combination of empirical and TRNSYS based analysis

shows that a manure to manure exchanger with similar heat addition rates to the cold slurry has an efficiency of approximately 0.211 (where efficiency is defined as the ratio of heat added to the cold fluid divided by the maximum amount of heat that can be transferred between fluids [16]). There are many ways to improve this efficiency through exchanger design. For simplicity's sake the length of the heat exchanger was the only modified variable to model an efficiency increase. Beginning with the current value of 0.211 (a heat exchanger length of 14 meters), the WHR efficiency is increased for subsequent simulations to evaluate the effects on system operation. Fig. 11 shows the results of these repeated simulations.

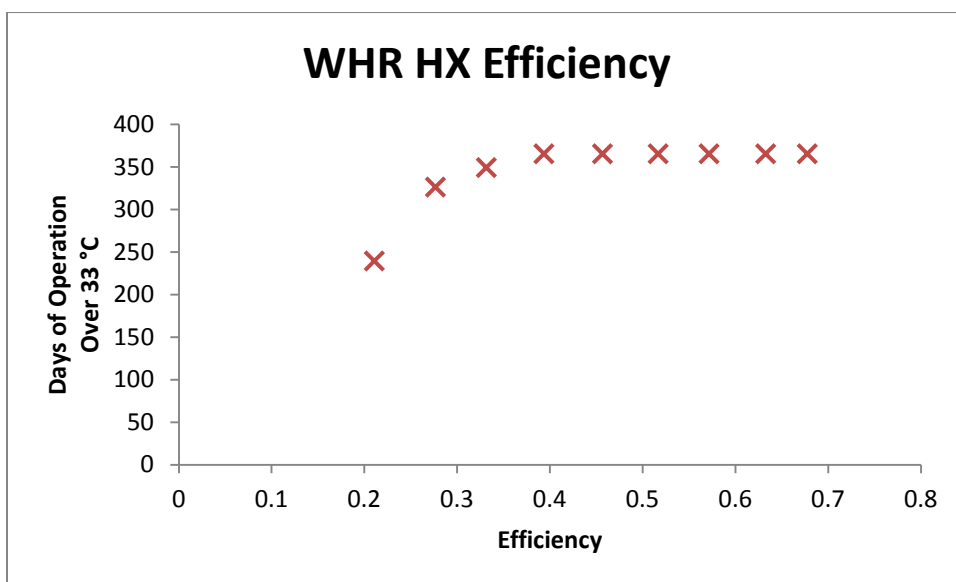

Fig. 11 - Waste Heat Recovery Optimization

Starting with an efficiency equivalent to the existing installation, the digesters operate above 33 °C for 239 days. Year round operation over 33 °C is achieved with an exchanger efficiency of 0.394 (a length of 34 meters). While higher efficiencies require very long heat exchanger lengths, snaking the tube-in-tube design would significantly reduce the required

footprint. From this analysis, it is clear that modifying just the WHR unit would achieve the goal of year round operation without the need for supplemental heating.

5.3 Main Shell and Tube Heat Exchanger

The next area for potential improvement is the efficiency of the main ST heat exchanger. Empirical analysis of this component shows that the unit currently has an efficiency of 0.564. Similar to the analysis of the WHR unit, the efficiency was increased for subsequent simulation runs to show the effects on potential operation. Again, the length was the modified variable to increase efficiency, but ST design offers many other design options (baffles, multiple passes, etc.) to increase efficiency. The results are presented in Fig. 12.

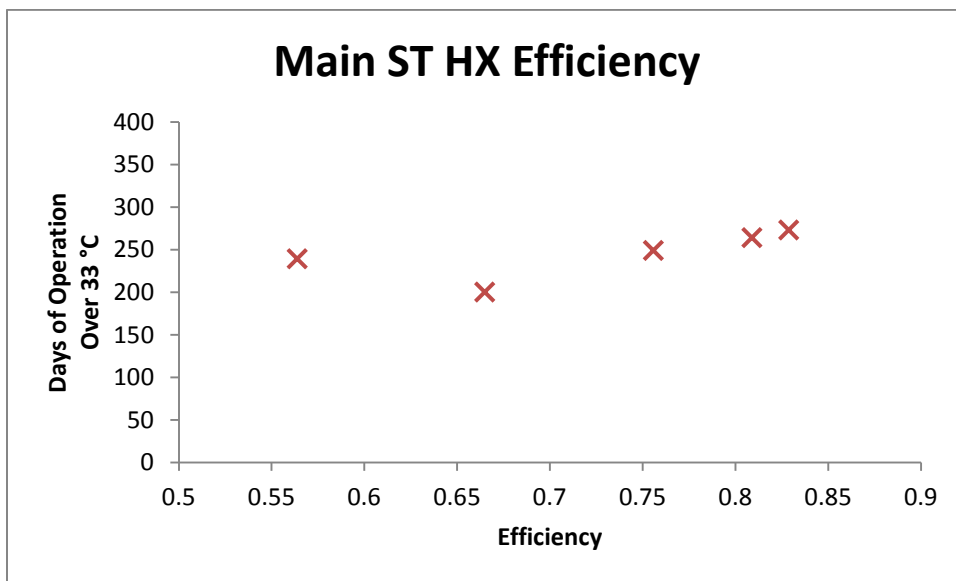

Fig. 12 - Main Shell and Tube Heat Exchanger Efficiency

The modification of efficiency on this exchanger presents an interesting phenomenon. Logic would lead one to believe that increasing this efficiency would yield higher year round

temperatures. This, however, is clearly not the case. Recall that the purpose of this exchanger is to transfer heat from the water loop (which collects heat from the engine-generator) to the manure slurry before reaching the tanks. The result of increasing the rate of energy transfer between the two streams significantly reduces the temperature of thermal storage on the water side. Because the overall heat transfer coefficient of an exchanger is defined in units of Watts per degree Celsius (or equivalent units), the decreased temperature difference between the water and manure loop counteracts the expected effects of an increased heat transfer rate.

Evaluating this modification in terms of increased days of operation is deceiving. The results shown are concerned with overall system efficiency, so the produced data does not provide the same representation as the previous analysis. Improving the efficiency of the main ST does have some positive effects. Figure 13 shows the resulting temperature profiles of the tanks for several different exchanger efficiencies.

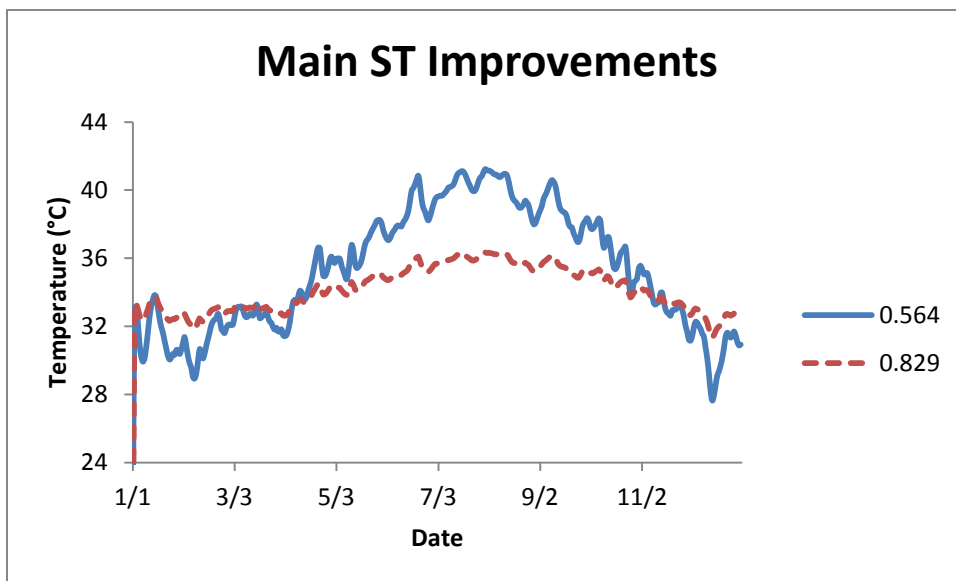

Fig. 13 - Tank Temperature Profiles for Main ST Improvements

The legend on the right shows the main ST efficiency for several simulations. The notable change from an increased main ST efficiency is the dampening of temperature fluctuations. While tank temperatures do not reach above 33 °C any more frequently, the tank temperatures are much more stable. Recalling the theory of anaerobic bacteria, drastic temperature changes can hinder operation. While an improvement to this exchanger does not seem appealing in terms of year round potential, it has a very appealing effect on digester stability due to more consistent temperatures.

5.4 Exhaust Shell and Tube Heat Exchanger

The third element of interest in performance improvement is the engine exhaust heat exchanger. A similar analysis method was used on the effects of increased efficiency to digester performance. Analysis of the current exhaust heat exchanger shows that it has an efficiency of 0.516 (at a length of 1 meter). The results of increased efficiency (through increasing the length) are shown in Fig. 14. Like the previous heat exchanger analyses, the unmodified exhaust heat exchanger allows the system to operate above 33 °C for 239 days. Improving the efficiency to over 0.9 would allow operation over 33 °C for the full year. The dips seen in performance at the higher efficiencies are merely a result of weather patterns interacting with the temperature control monitoring in the tanks.

5.5 Biogas Use

If no improvements were made to heat utilization in the digester system, there is still a potential solution for increasing the amount of available energy. Chilling the biogas, and thus reducing the amount of moisture, significantly increases the heating value and energy output.

While there is already a unit installed, the operator does not use it prior to combustion in the engine. A simple thermodynamic analysis will show the added benefit of chilling the biogas.

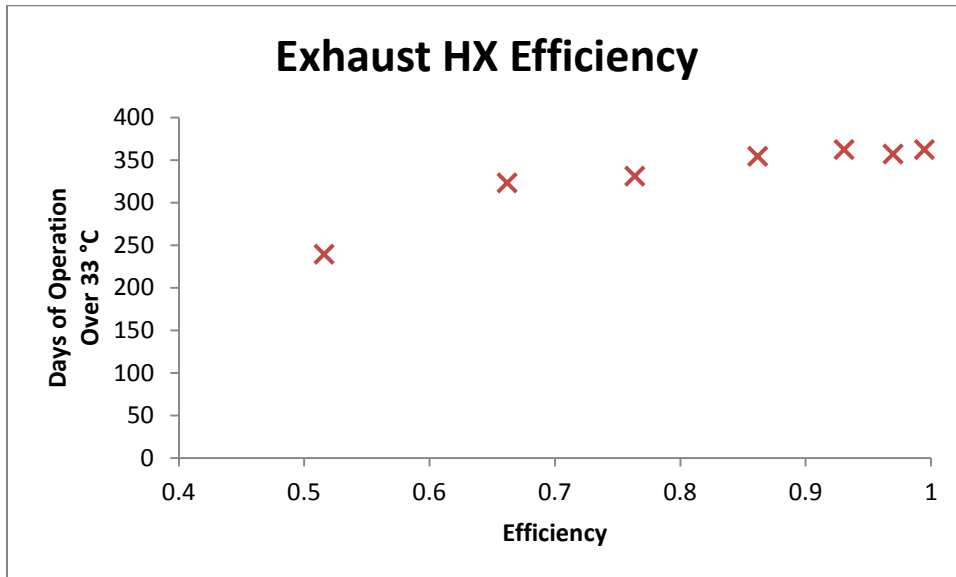

Fig. 14 - Exhaust Shell and Tube Heat Exchanger Efficiency

Assuming a biogas methane content of 70% [2], the projected lower heating value (LHV) of dry biogas at STP is 25,033 kJ/m³[14]. Accounting for pressure, temperature and moisture reduces the LHV to 86.3% of the dry value (21,603 kJ/m³). Assuming an average gas production of 520 m³/day, this equates to an energy availability of 130 kW. If this gas is used strictly in the engine-generator, a simple assumption is that 1/3 is converted to electricity while the remaining 2/3 is transferred to the exhaust stream and block coolant equally (with a small portion lost to the environment) [17]. This means that the engine is capable of generating approximately 43.4 kW. Alternatively, if the gas were run through the chiller, dropping the temperature down to approximately 20 °C (from 35 °C), the LHV is 94.5% of the dry value (23,656 kJ/m³) as a result of the decreased moisture content [14]. Running this through the engine-generator then yields

47.5 kW of electricity. From this simple analysis, chilling the biogas can increase energy availability by almost 10%.

A simple energy balance on the gas stream shows the energy cost of this cooling through Eq. (7).

$$Q = m * c * \Delta T \quad (7)$$

Q is the energy required to cool the gas, m is the mass (1 m³ at a density of 0.982 kg/m³), c is the specific heat (1.22 kJ/(kg*°C) and T is the temperature change (35°C - 20°C) (gas properties taken from [5]). This means that chilling the biogas 15°C will cost about 0.1 kW. Considering the effect on heating value, the energy availability will increase 12.4 kW (4.1 kW of which are electricity output, the remaining is heat). This simple analysis shows that the cost of chilling is negligible when compared to the added value of removing the moisture.

Similar to the effects of heat exchanger optimization on digester performance, simulations were conducted to analyze the effect of increased engine output on digester performance. The results are shown in Fig. 15. While biogas conditioning does not have as significant of an effect on system performance as heat utilization, it still shows some improvements. If the biogas were chilled down to 15 °C (from 35 °C, for a ΔT of 20 °C), operation above any temperature level increases by 15-30 days.

5.6 Effects of Multiple Improvements

The previous sections considered the effects of individual changes to the system. This section considers the interaction of combined improvements. Because SDDS already has a biogas chiller installed, all following simulations will assume the chiller is operational, and the gas is chilled to 15 °C. Figure 16, Fig. 17, and Fig. 18 show the simulation results with the increased gas heating value. Comparing these results to Fig. 11, Fig. 12, and Fig. 14 clearly shows the added

value of the chilled biogas. Changes in each of the three major elements (WHR, main ST and engine exhaust exchangers) will be discussed with respect to changes of the remaining two.

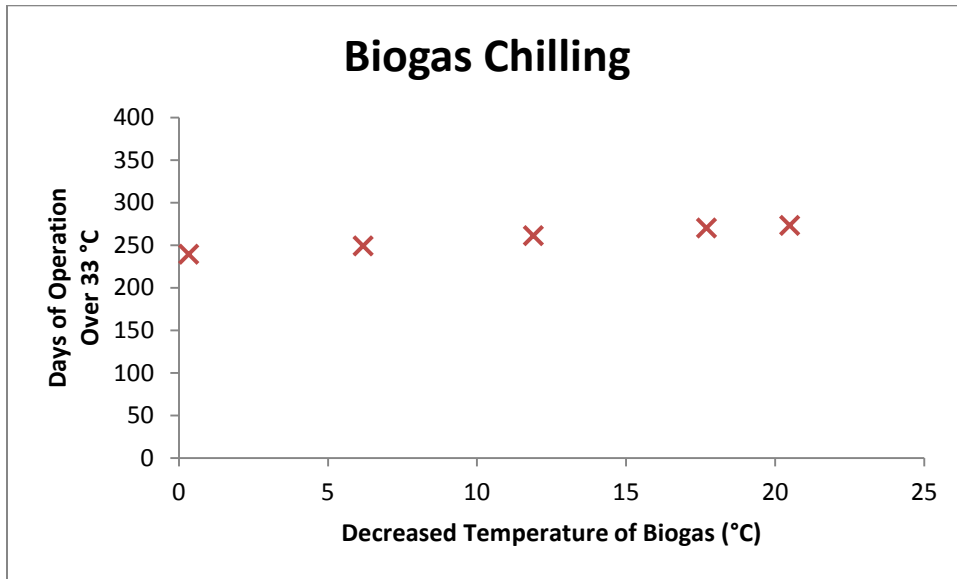

Fig. 15 - Engine Power Output

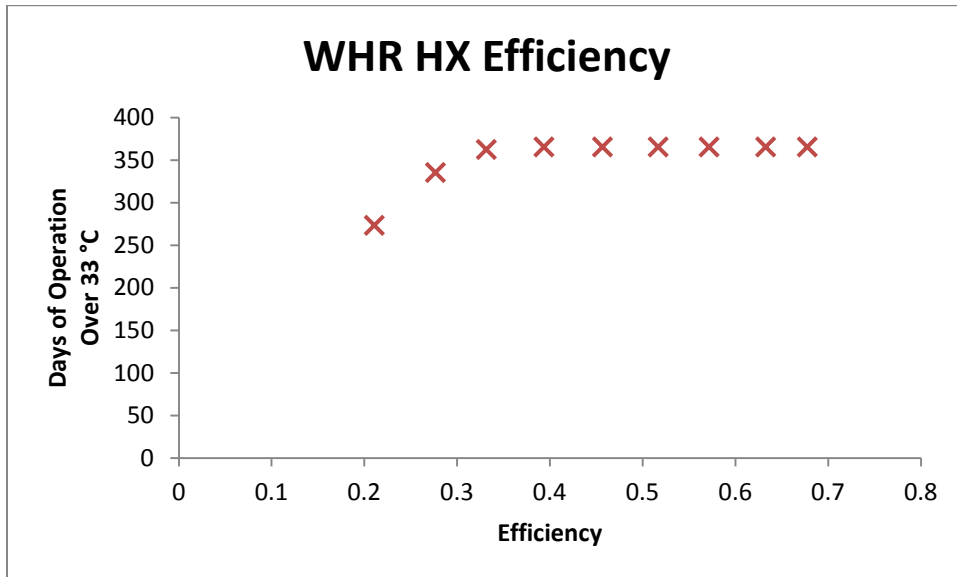

Fig. 16 - WHR Improvements after Biogas Conditioning

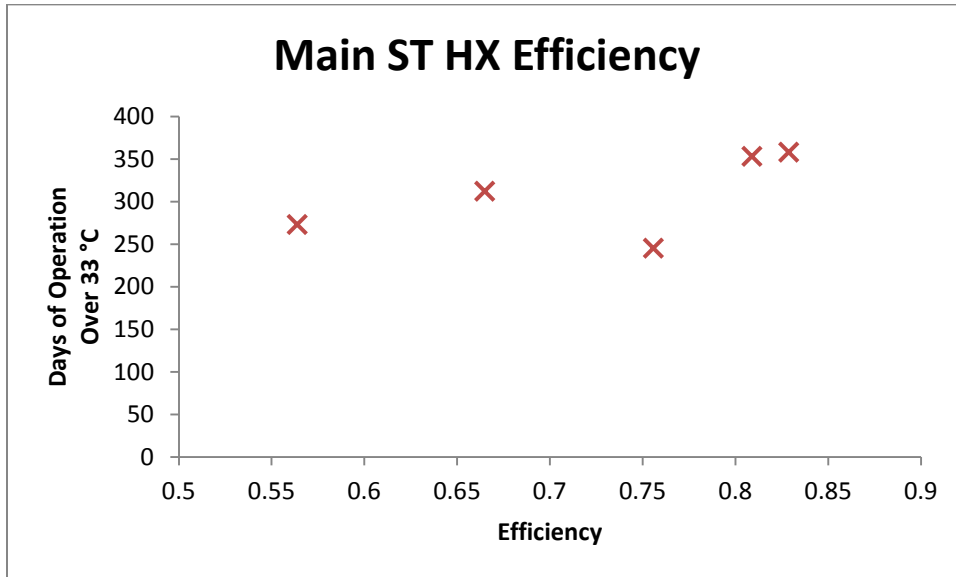

Fig. 17 - Main ST Improvements after Biogas Conditioning

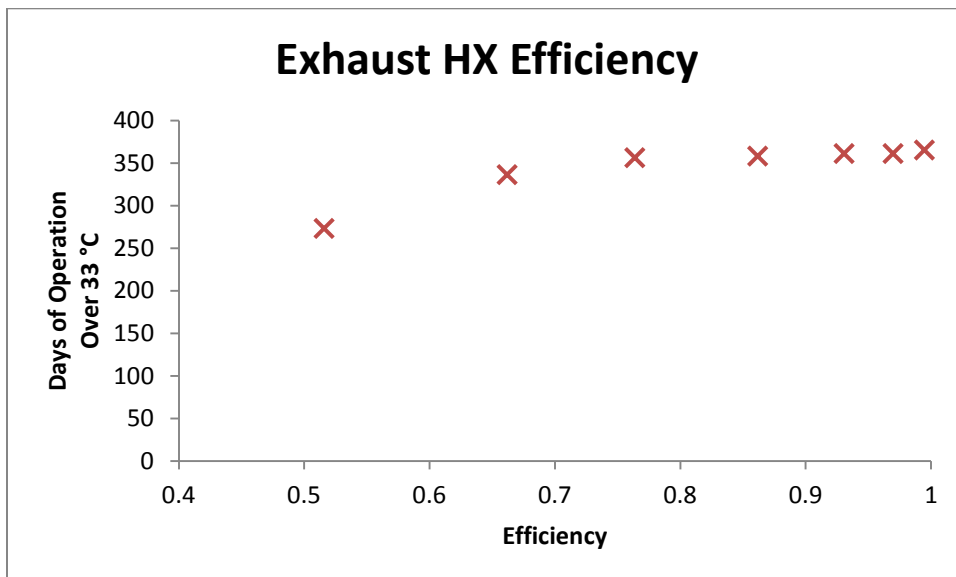

Fig. 18 - Exhaust Exchanger Improvements after Biogas Conditioning

5.6.1 WHR with Respect to Others

Modifications to the WHR unit were shown to have the most profound effects on digester temperatures. Combining upgrades to this unit with modifications of the other two options do not show much of a difference on year round potentials. Figure 19 shows the combined effects of improvements to both the WHR and main ST exchangers. Using the legend in the following graph, the x markers represent the case where the main ST exchanger is not improved. Each marker represents a different efficiency for the WHR unit. Different markers represent improved efficiencies for the ST. Recall from 5.3 that upgrades to the ST had no serious effect on performance.

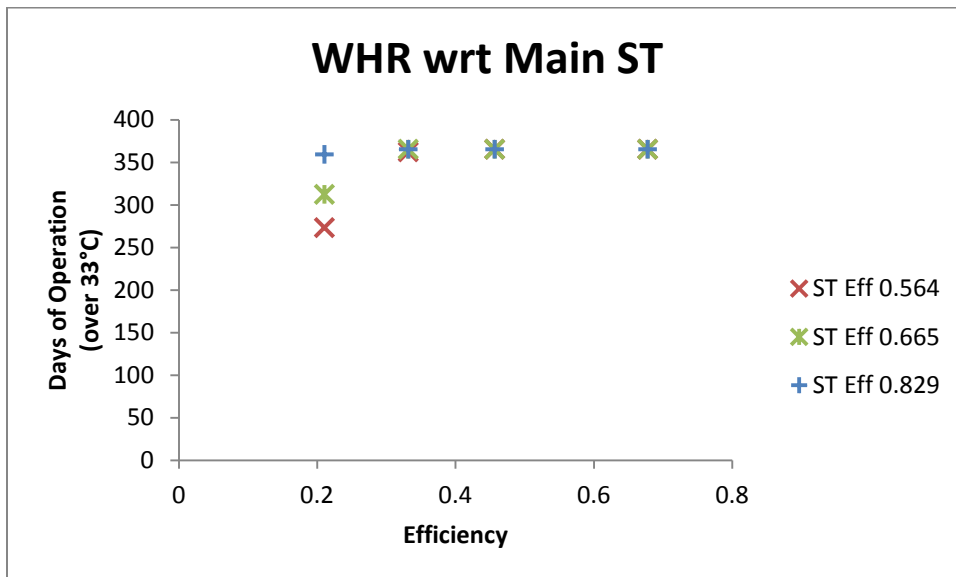

Fig. 19 - WHR wrt Main ST

Changes to the WHR unit are also combined with changes to the exhaust heat exchanger.

These results are shown in Fig. 20. The results of this graph are fairly straight forward.

Modifications to both of these exchangers will improve the year round potential operation of the digesters.

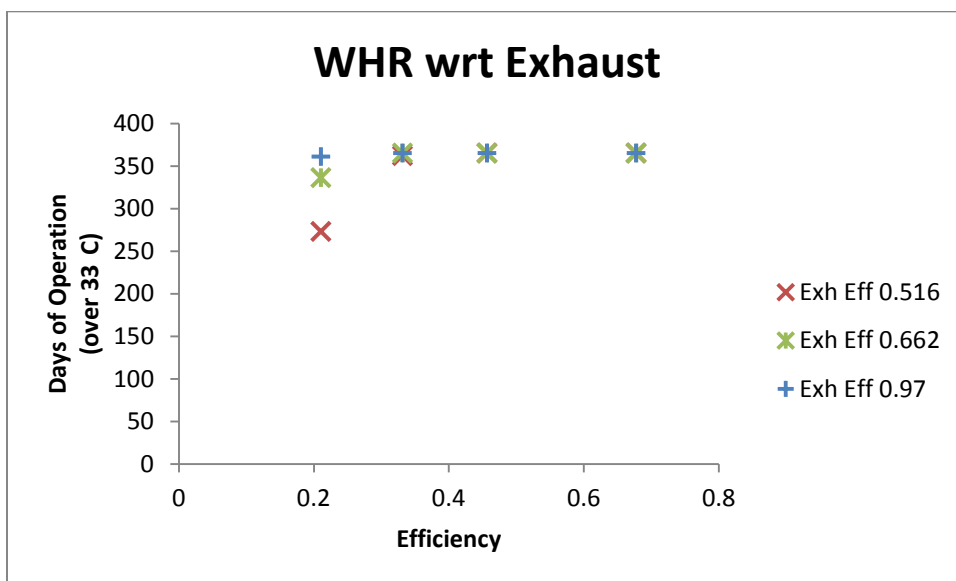

Fig. 20 - WHR wrt Exhaust

5.6.2 Main Shell and Tube with Respect to Others

These next figures consider the effects of other improvements on modifications to the main ST exchanger. First, Fig. 21 shows the combination of improvements to the main ST with improvements to the WHR unit. Effects of main ST improvements combined with exhaust exchanger improvements are shown in Fig. 22. Consider the purpose of the three exchangers in this system. The WHR unit adds heat to the incoming manure, the exhaust exchanger adds heat to the water loop, and the Main ST transfers heat from the water loop to the manure stream. Unless there is sufficient heat to maintain the water loop at a high temperature, increasing the heat transfer rate from the water loop to the manure stream will actually decrease the steady state

temperature of the water loop. The smaller temperature difference between the two streams then decreases the potential temperature gains of the manure stream.

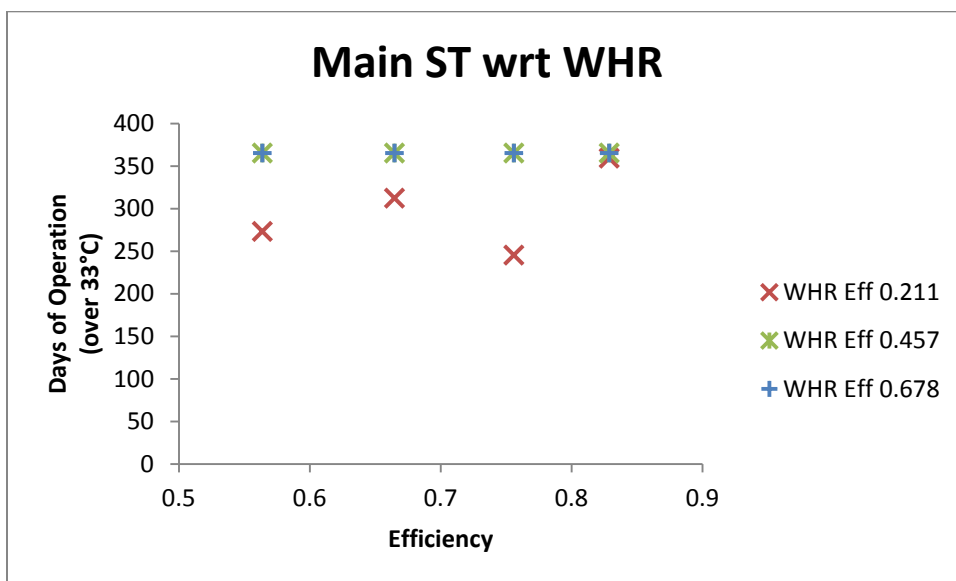

Fig. 21 - Main ST wrt WHR

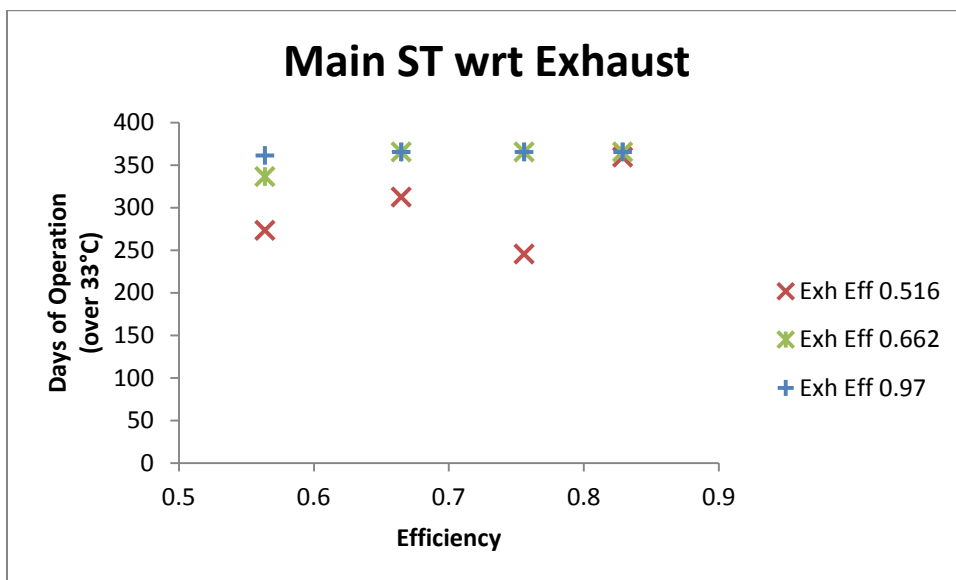

Fig. 22 - Main ST wrt Exhaust

5.6.3 Exhaust Heat Exchanger with Respect to Others

For validation purposes, the scenarios above are now presented with modifications to the exhaust exchanger as the variable of interest, and the other two as secondary. First, Fig. 23 shows effects of exhaust exchanger improvements with respect to WHR improvements. Comparing this graph to Fig. 20, it is clear that improvements to the WHR unit have a much bigger effect on system performance than improvements to the exhaust exchanger.

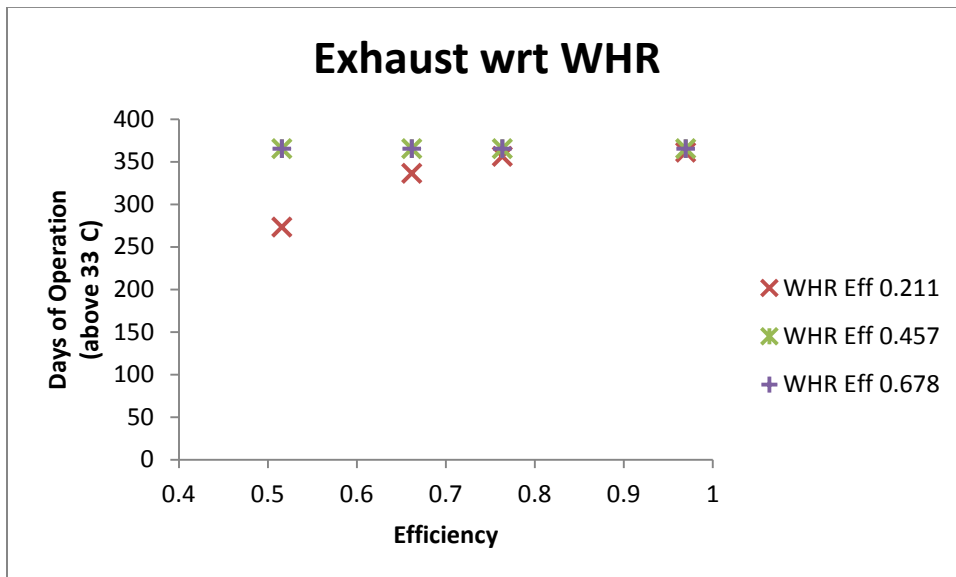

Fig. 23 - Exhaust wrt WHR

The final graph combines improvements to the exhaust exchanger with improvements to the main ST exchanger, seen in Fig. 24.

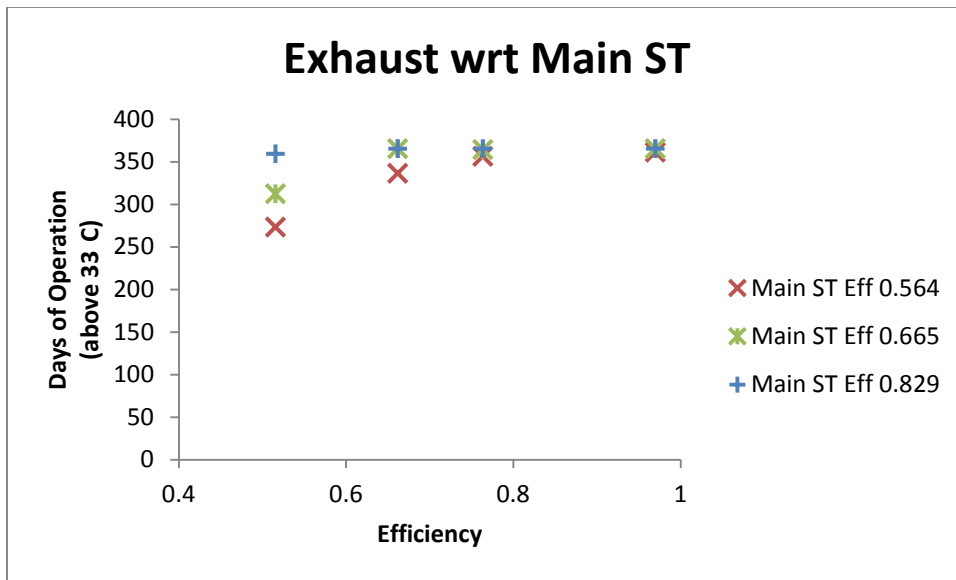

Fig. 24 - Exhaust wrt Main ST

CONCLUSIONS AND RECOMMENDATIONS

6.1 Conclusions

Anaerobic digestion is subject to an increasing number of studies. Not only is it a fascinating topic, but it is very practical in its application as waste mitigation and energy generation. In order for it to be effective, however, the system requires heat energy to maintain adequate temperatures for the involved bacteria. This proves even more important in regions with cold winter months. Some systems rely on natural gas to provide this heat, while many others are turning towards using the produced biogas to provide heat. Using just the biogas to provide this heat can prove difficult for poorly designed systems, especially in cold climates. This study has shown, however, that design improvements and proper gas utilization make it possible to maintain temperatures even above the mesophilic range year round.

The computer model, constructed through TRNSYS, was used to show the effects of certain design improvements on system operation. Not only is this modeling reliable from its in depth scientific development, but it saves time and effort by predicting results through computer simulation. The major focus of running simulations with the computer model was to qualify the effects of waste heat recovery and engine heat utilization on a real world digester system. The effects of modifying heat exchanger efficiencies were shown in terms of year round potential.

The four main areas of interest in this study were waste heat recovery improvement, heat transfer from the heat loop to the manure stream (through the main shell and tube exchanger), energy gain from engine exhaust, and biogas utilization. The most notable result of this study is that with a properly designed waste heat recovery unit, year-round digester operation is possible in even the coldest of winter months. In fact, with a high enough WHR efficiency, temperatures can be maintained even above 40 °C. Improving the exhaust heat recovery also adds some

potential to the system, although not as notably as waste heat recovery from the effluent digester stream. Heat availability is very important. If heat transfer rates from the thermal storage loop are too high to match heat availability, then system potential will actually suffer. On the other hand, tank temperatures show much more stability. Finally, proper biogas utilization can help add a significant amount of available heat to the system. By chilling the saturated biogas stream to remove the moisture, the heat content and energy output of the fuel goes up by as much as 10%.

6.2 Recommendations

As a result of this study, several recommendations can be made for the Sunderland Dairy Digester System. Most importantly, the waste heat recovery unit is severely under designed. By modifying the unit to operate without a need for a water loop intermediary and increasing the efficiency, the digester system has the potential to operate year round. Furthermore, using the already installed biogas chiller will provide a significant amount of extra energy. While the main shell and tube and exhaust heat exchangers could undergo some improvements, the added benefits are minor when compared to the other two modifications.

While this analysis provides a good insight into the outcomes of various system improvements, the simulation model is not entirely accurate. There are several factors which have not been taken into account yet, which may provide a more realistic model in the future. For example, the simulation model assumes the influent manure never contains any ice. From practical experience, however, this is not the case. The latent heat of fusion required to melt ice will significantly reduce the maximum winter tank temperatures. Another shortcoming of this approach is that feed rate and manure slurry characteristics are assumed constant. Because of weather and operational requirements, however, HRT and feedstock characteristics will likely fluctuate. This, in turn, would result in a varied gas production from the current prediction.

Despite these shortcomings, this study provides a reliable analysis for the relevant changes expected from various design improvements to the SDDS.

REFERENCES

- [1] Dustin, J. S., 2010, "Fundamentals of Operation of the Induced Bed Reactor (IBR) Anaerobic Digester", <http://digitalcommons.usu.edu/etd/554/>
- [2] Gale, J. A., Zemke, P. E., Wood, B. D., Sunderland, S., and Weeks, S. A., 2009, "Comparison of Induced Sludge Bed (Blanket) Anaerobic Reactor to Vertical Plug Flow Technology for Animal Manure Digestion," Salt Lake City, Utah.
- [3] Zemke, P. E., Dustin, J. S., Gale, J. A., and Wood, B. D., 2011, "Full-Scale Performance Comparison of an Induced Bed Reactor and a Control Reactor," Biol. Eng. Trans. Biological Engineering Transactions, 4(3), pp. 147-156.
- [4] Gerardi, M. H., 2003, *The Microbiology of Anaerobic Digesters*, Wiley-Interscience, Hoboken, New Jersey.
- [5] Gunnerson, C. G., and Stuckey, D., 1986, *Anaerobic Digestion : Principles and Practices for Biogas Systems*, World Bank, Washington, D.C., U.S.A.
- [6] Varel, V. H., Hashimoto, A. G., and Chen, Y. R., 1980, "Effect of Temperature and Retention Time on Methane Production from Beef Cattle Waste," Applied and Environmental Microbiology, 40(2), pp. 217-22.
- [7] Zemke, P. E., 2009, "Full-Scale Biogas Production in Two Types of Anaerobic Digesters Using Separated Dairy Manure," Proc. Utah State University Graduate Student Symposium, Logan, Utah.
- [8] Cockett, N., July 2010, "Retrofit Applications to Anaerobic Digester Electric Power System," Utah Science Technology and Research (USTAR) Biofuels Initiative, Logan, Utah.
- [9] Carrigan, C., Phillips, N., and Wood, B., 2010, "Sunderland Dairy Digester Report," Utah State University, Logan, Utah.
- [10] Solar Energy Laboratory, U. O. W.-M., 2007, "Trnsys 16," Madison, Wisconsin, <http://sel.me.wisc.edu/trnsys>
- [11] Hansen, C. L., Hansen, C. S., Watts, E. D., and Pack, K. D., 2002, "Induced Sludge Bed Anaerobic Reactor," Utah State University, Logan, Utah
- [12] Shuler, M. L., and Kargi, F., 2002, *Bioprocess Engineering*, Prentice Hall, Upper Saddle River, New Jersey.

- [13] Association, D. W. I., 2011, Windpower.Org, <http://guidedtour.windpower.org/en/core.htm>
- [14] Ludington, D., 2005, "Calculating the Heating Value of Biogas," DLTech, Inc, Ithaca, New York.
- [15] Incropera, F. P., and Dewitt, D. P., 2007, *Fundamentals of Heat and Mass Transfer*, John Wiley, New York.
- [16] Janna, W. S., and Chhabra, R. P., 2011, *Design of Fluid Thermal Systems*, Cengage Learning, Stamford, Conn.
- [17] Wallace, S. J., 2008, "Diesel Engine Energy Balance Study Operating on Diesel and Biodiesel Fuels", <http://www.ohiolink.edu/etd/view.cgi?ohiou1212586902>

APPENDICES

APPENDIX A – EMPIRICAL ANALYSIS

The following pages are examples of the empirical methods used in analyzing the SDDS. While all calculations have not been included (to avoid redundancy), the included examples provide enough base to understand how to modify them for the other approaches. For example, three separate calculations were completed on double pipe heat exchangers, but only one example of a counterflow configuration was included here. Also

A.1 Tank Loss Coefficient

Problem statement: A 10-m tall cylindrical tank is constructed with 1/4" thick steel. The tanks holds water at 37 C, while in a room kept at 32 C. Determine the heat transferred through the tank wall.

Assumptions:

1. The system is at steady state
2. Material properties are constant
3. Air properties are constant
4. Radiation heat transfer is neglected

Solution: The digester wall only consists of one layer of steel, so there are three elements of resistance to heat transfer. The first is free convection from the water to the tank wall, the second is conduction through the tank wall, and the third is free convective from the tank wall to the air. This leads to four temperatures of interest, T_1 is the water temperature, T_2 is the wall temperature at the water surface, T_3 is the wall temperature at the air surface and T_4 is the air temperature.

Properties of the fluids at the given temperatures are as follows

Water: $T_1 = 310\text{K}$

$$\begin{aligned} \rho_w &= 994 \frac{\text{kg}}{\text{m}^3} & C_{pw} &= 4178 \frac{\text{J}}{\text{kg}\cdot\text{K}} & k_{fw} &= 0.628 \frac{\text{W}}{\text{m}\cdot\text{K}} \\ v_w &= 6.58 \cdot 10^{-7} \frac{\text{m}^2}{\text{s}} & \alpha_w &= 1.512 \cdot 10^{-7} \frac{\text{m}^2}{\text{s}} & Pr_w &= 4.34 \end{aligned}$$

Air: $T_4 = 305\text{K}$

$$\begin{aligned} \rho_a &= 1.177 \frac{\text{kg}}{\text{m}^3} & C_{pa} &= 1005.7 \frac{\text{J}}{\text{kg}\cdot\text{K}} & k_{fa} &= 0.02624 \frac{\text{W}}{\text{m}\cdot\text{K}} \\ v_a &= 15.68 \cdot 10^{-6} \frac{\text{m}^2}{\text{s}} & \alpha_a &= 0.2216 \cdot 10^{-4} \frac{\text{m}^2}{\text{s}} & Pr_a &= 0.708 \end{aligned}$$

Properties of the steel tanks are as follows.

$$k_{\text{tank}} = 14.3 \frac{\text{W}}{\text{m}\cdot\text{K}} \quad x_{\text{tank}} = 0.0064\text{m}$$

Heat transferred through the wall is defined as

$$q = \frac{T_1 - T_4}{R_{12} + R_{23} + R_{34}}$$

The resistances are defined as

$$R_{12} = \frac{1}{h_w \cdot A} \quad R_{23} = \frac{x_{\text{tank}}}{k_{\text{tank}} \cdot A} \quad R_{34} = \frac{1}{h_a \cdot A}$$

Each resistance contains a term for the area of heat transfer. To simplify calculation, a value of 1 m^2 will be applied.

$$R_{12} = \frac{1}{h_w} \quad R_{23} = \frac{x_{\text{tank}}}{k_{\text{tank}}} = 4.476 \cdot 10^{-4} \frac{\text{K}}{\text{W}} \quad R_{34} = \frac{1}{h_a}$$

To determine the natural convection coefficient for a vertical wall, the Churchill-C equation is used.

$$\text{Nu} = \frac{h \cdot L}{k_f} = 0.68 + \frac{0.67 \text{Ra}^{\frac{1}{4}}}{\left[1 + \left(\frac{0.492}{\text{Pr}} \right)^{\frac{9}{16}} \right]^{\frac{4}{9}}}$$

The length term here refers to wall height, which has been assumed to be 1 m. This gives

$$h_w = 0.427 + 0.375 \text{Ra}_w^{\frac{1}{4}} \quad h_a = 0.018 + 0.013 \text{Ra}_a^{\frac{1}{4}}$$

Where

$$\text{Ra} = g \cdot \frac{\beta \cdot (T_s - T_{\text{inf}}) \cdot L^3}{\nu \cdot \alpha} < 10^9 \quad 0 < \text{Pr} = \frac{\nu}{\alpha} < \text{inf}$$

$$\beta_a = \frac{1}{T_{\text{inf}}} \quad \beta_w = \frac{207 \cdot 10^{-6}}{\text{K}}$$

Using the appropriate temperatures and simplifying gives the following equations.

$$\text{Ra}_w = 2.041 \cdot 10^{10} (T_1 - T_2) \quad \text{Ra}_a = 9.21 \cdot 10^7 \cdot (T_3 - T_4)$$

Other forms of the equation for heat transfer through the wall can be written as

$$q = \frac{T_1 - T_2}{R_{12}} \quad q = \frac{T_3 - T_4}{R_{34}}$$

These can be rearranged to find the unknown temperatures

$$T_2 = T_1 - q \cdot R_{12} \quad T_3 = T_4 + q \cdot R_{34}$$

An iterative method to calculate the unknown temperatures (and thus heat transfer and resistances) is now applied as follows.

1. Assume $T_1=T_2$ and $T_3=T_4$ and calculate the following
2. R_{aw} and R_{aa}
3. h_w and h_a
4. R_w and R_a
5. q
6. Refined values for T_2 and T_3

T1	T4	T2	T3	R _{aw}	R _{aa}	h _w	h _a	R _w	R _a	R _{wall}	q
K	K	K	K			W/(m ² *K)	W/(m ² *K)	K/W	K/W	K/W	W/m ²
310	305	310	305	0.0E+00	0.0E+00	0.427	0.018	2.342	55.556	0.00045	0.086
310	305	309.8	309.8	4.1E+09	4.4E+08	95.48	1.90	0.010	0.526	0.00045	9.320
310	305	309.9	309.9	2.0E+09	4.5E+08	79.65	1.91	0.013	0.523	0.00045	9.331
310	305	309.9	309.9	2.4E+09	4.5E+08	83.35	1.91	0.012	0.523	0.00045	9.332
310	305	309.9	309.9	2.3E+09	4.5E+08	82.42	1.91	0.012	0.523	0.00045	9.332
310	305	309.9	309.9	2.3E+09	4.5E+08	82.65	1.91	0.012	0.523	0.00045	9.332
310	305	309.9	309.9	2.3E+09	4.5E+08	82.59	1.91	0.012	0.523	0.00045	9.332
310	305	309.9	309.9	2.3E+09	4.5E+08	82.60	1.91	0.012	0.523	0.00045	9.332
310	305	309.9	309.9	2.3E+09	4.5E+08	82.60	1.91	0.012	0.523	0.00045	9.332

Once an acceptable convergence is reached, the convective heat transfer coefficients can be used to determine the overall heat loss coefficient for the tanks. The overall heat transfer coefficient is defined as

$$U = \frac{1}{A \cdot R_{tot}} \quad R_{tot} = \frac{1}{h_w \cdot A} + \frac{x_{tank}}{k_{tank} \cdot A} + \frac{1}{h_a \cdot A} = 0.536 \frac{K}{W}$$

$$U = 1.865 \frac{W}{m^2 \cdot K} = 6715 \frac{J}{hr \cdot m^2 \cdot K}$$

A.2 Building Loss Coefficient

Problem statement: A large, insulated building is used to house digester tanks. Use building properties to determine the heat transferred through building to the outside environment. The building has dimensions of 15x18 meters, and a height of 13 meters. The building is insulated with 3 inch thick R-12 insulation. The building is constructed with 18 gauge stainless steel siding. The building also has 2 large doors, uninsulated, with a total area of 25 m².

Assumptions:

1. The system is at steady state
2. Material properties are constant
3. Air properties are constant
4. Radiation heat transfer is neglected

Solution: Similar to the calculation of the tank loss coefficient, this analysis requires identification of the various resistances and convection coefficients. The addition of insulation and uninsulated doors slightly complicates the analysis, but the approach is still the same. There are four resistances to consider. The first is free convection from the building air to the wall surface (insulation or steel door). Next is conduction through the insulation to the steel wall. Third is conduction through the steel wall (either from the insulation or from the free convection surface). Finally is the forced convection from the steel wall to the outside air. The total resistances through the insulated and uninsulated portions will first be calculated, and then combined in parallel to identify the total heat loss of the building.

Building Dimensions

$$L_b := 15\text{m} \quad W_b := 18\text{m} \quad H_b := 13\text{m} \quad A_d := 25\text{m}^2$$

$$A_b := 2 \cdot L_b \cdot H_b + 2 \cdot W_b \cdot H_b + L_b \cdot W_b =$$

$$A_{\text{ins}} := A_b - A_d =$$

Material Properties

$$k_{\text{ins}} := 0.027 \frac{\text{W}}{\text{m} \cdot \text{K}} \quad x_{\text{ins}} := 0.076\text{m}$$

$$k_{\text{ste}} := 15.1 \frac{\text{W}}{\text{m} \cdot \text{K}} \quad x_{\text{ste}} := 0.00127\text{m}$$

Rather than follow through with the iterative technique used in the tank analysis, convective coefficients can be assumed. The free convection coefficient for the building air found in the tank analysis will be used. For the forced convection outside, a value of 100 W/(m²·K) is assumed. These assumptions are acceptable because the conduction resistance is so large when compared to the convection resistances.

$$h_{\text{free}} := 1.91 \frac{\text{W}}{\text{m}^2 \cdot \text{K}} \quad h_{\text{forced}} := 100 \frac{\text{W}}{\text{m}^2 \cdot \text{K}}$$

The total resistance through the insulated portion of the building (modelled in series) is calculate as follows

$$R_{\text{ins}} := \frac{1}{h_{\text{free}} \cdot A_{\text{ins}}} + \frac{x_{\text{ins}}}{k_{\text{ins}} \cdot A_{\text{ins}}} + \frac{x_{\text{ste}}}{k_{\text{ste}} \cdot A_{\text{ins}}} + \frac{1}{h_{\text{forced}} \cdot A_{\text{ins}}} = \cdot \frac{\text{K}}{\text{W}}$$

Similarly, the resistance through the door portion of the building is calculated as follows

$$R_{\text{door}} := \frac{1}{h_{\text{free}} \cdot A_{\text{d}}} + \frac{x_{\text{ste}}}{k_{\text{ste}} \cdot A_{\text{d}}} + \frac{1}{h_{\text{forced}} \cdot A_{\text{d}}} = \cdot \frac{\text{K}}{\text{W}}$$

Because the heat has two paths it can travel (insulation or doors), the total resistance is modelled as the two individual being in parallel.

$$R_{\text{tot}} := \frac{1}{\frac{1}{R_{\text{ins}}} + \frac{1}{R_{\text{door}}}} = \cdot \frac{\text{K}}{\text{W}}$$

The total resistance of the building can now be used to calculate the overall heat loss coefficient

$$U_{\text{tot}} := \frac{1}{A_{\text{b}} \cdot R_{\text{tot}}} = \cdot \frac{\text{W}}{\text{m}^2 \cdot \text{K}} \qquad U_{\text{tot}} = \cdot \frac{\text{joule}}{\text{hr} \cdot \text{m}^2 \cdot \text{K}}$$

A.3 Engine Exhaust Flow

Stoichiometry can be used to determine the engine exhaust flow rates. Combustion of biogas and oxygen can be written as

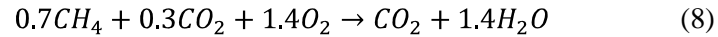

This means that for every mole of biogas to be combusted, 1.4 moles of oxygen are needed. The oxygen used in combustion comes from air so nitrogen will play a large role in determining flow rates. Including nitrogen, the stoichiometric combustion becomes this.

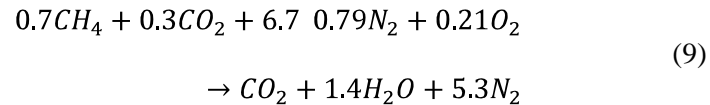

For every mole of biogas combusted, 6.7 moles of air are needed. The molecular weights of biogas and the exhaust components are used to develop a relationship between biogas and exhaust flow rates. First, the molecular weight of biogas is calculated as

$$0.7 * 16 \frac{kg}{mol} + 0.3 * 44 \frac{kg}{mol} = 24.4 \frac{kg}{mol} \quad (10)$$

The molecular weight of the exhaust is

$$\begin{aligned} 1 \text{ mol}_{bg} * 44 \frac{kg}{mol} + 1.4 \text{ mol}_{bg} * 18 \frac{kg}{mol} \\ + 5.3 \text{ mol}_{bg} * 28 \frac{kg}{mol} \\ = 217.6 \frac{kg}{mol_{bg}} \end{aligned} \quad (11)$$

These two numbers are then combined to calculate the mass of exhaust per mass of biogas.

$$\frac{217.6 \text{ kg}_{exh} \text{ mol}_{bg}}{24.4 \text{ kg}_{bg} \text{ mol}_{bg}} = 8.9 \text{ kg}_{exh} \text{ kg}_{bg} \quad (12)$$

A.4 Dual Pipe Counter Flow Heat Exchanger

The following analysis shows how the waste heat recovery unit was evaluated. This method dire follows the one developed in the textbook Design of Thermal Fluid Systems by William S. Janna.

Problem Statement: Manure slurry (properties assumed identical to water) at a temperature of 3 C and a mass flow 0.63 kg/s is used to heat water at a temperature of 23.5 C and a flow rate of 2.14 kg/s. A counterflow double pipe heat exchange is used that is constructed with an annulus of nominal 2.5 in. Schedule 40 pipe and an inner pipe of nominal 1.5 in. Schedule 40 pipe. The exchanger has a total length of 14 meters. Determine the outlet temperatures of each fluid and the efficiency of the exchanger.

Nomenclature:

1. T refers to the temperature of the warmer fluid.
2. t refers to the temperature of the colder fluid
3. h subscript refers to the hotter fluid
4. c subscript refers to the colder fluid
5. a subscript refers to the annular flow area or dimension
6. p subscript refers to the tubular flow area or dimension
7. 1 subscript refers to the inlet condition
8. 2 subscript refers to the outlet condition
9. e subscript refers to the equivalent diameter
10. hy subscript refers to the hydraulic diameter

A. Fluid Properties

Slurry, Inner tube

$$m_h := 0.63 \frac{\text{kg}}{\text{s}} = \frac{\text{kg}}{\text{hr}} \quad T_1 := (273 + 35)\text{K}$$

$$\rho_h := 994 \frac{\text{kg}}{\text{m}^3} \quad C_{ph} := 4178 \frac{\text{J}}{\text{kg}\cdot\text{K}} \quad k_{fh} := 0.628 \frac{\text{W}}{\text{m}\cdot\text{K}}$$

$$v_h := 6.5810^{-7} \frac{\text{m}^2}{\text{s}} \quad \alpha_h := 1.51210^{-7} \frac{\text{m}^2}{\text{s}} \quad Pr_h := 4.34$$

Water, Annulus

$$m_c := 2.14 \frac{\text{kg}}{\text{s}} = \frac{\text{kg}}{\text{hr}} \quad t_1 := (273 + 23.5)\text{K}$$

$$\rho_c := 1000 \frac{\text{kg}}{\text{m}^3} \quad C_{pc} := 4181 \frac{\text{J}}{\text{kg}\cdot\text{K}} \quad k_{fc} := 0.597 \frac{\text{W}}{\text{m}\cdot\text{K}}$$

$$v_c := 10.0610^{-7} \frac{\text{m}^2}{\text{s}} \quad \alpha_c := 1.4310^{-7} \frac{\text{m}^2}{\text{s}} \quad Pr_c := 7.02$$

B. Tube Sizes

$$ID_a := 2.47\text{in} \quad ID_p := 1.6\text{in} \quad OD_p := 1.9\text{in}$$

C. Flow Areas

$$A_p := \frac{\pi \cdot ID_p^2}{4} = \quad A_a := \frac{\pi \cdot (ID_a^2 - OD_p^2)}{4} =$$

D. Fluid Velocities

$$V_p := \frac{m_h}{\rho_h \cdot A_p} = \qquad V_a := \frac{m_c}{\rho_c \cdot A_a} =$$

E. Annulus Equivalent Diameter

$$\text{Friction} \qquad D_{hy} := ID_a - OD_p =$$

$$\text{Heat Transfer} \qquad D_e := \frac{(ID_a^2 - OD_p^2)}{OD_p} =$$

F. Reynolds Number

$$Re_p := \frac{V_p \cdot ID_p}{v_h} =$$

$$Re_a := \frac{V_a \cdot D_e}{v_c} =$$

G. Nusselt Numbers

Modified Dittus-Boelter Equation for Turbulent Flow

$$Nu_h := 0.023 (Re_p)^{\frac{4}{5}} \cdot Pr_h^{0.3} =$$

$$Nu_c := 0.023 (Re_a)^{\frac{4}{5}} \cdot Pr_c^{0.4} =$$

H. Convection Coefficients

$$h_i := \frac{Nu_h \cdot k_{fh}}{ID_p} = \cdot \frac{W}{m^2 \cdot K}$$

$$h_p := \frac{h_i \cdot ID_p}{OD_p} = \cdot \frac{W}{m^2 \cdot K}$$

$$h_a := \frac{Nu_c \cdot k_{fc}}{D_e} = \cdot \frac{W}{m^2 \cdot K}$$

I. Exchanger Coefficient

$$U_0 := \frac{1}{\frac{1}{h_p} + \frac{1}{h_a}} = \cdot \frac{W}{m^2 \cdot K}$$

$$U_0 = \cdot \frac{J}{hr \cdot m^2 \cdot K}$$

J. Outlet Temperature Calculations (Counterflow)

$$L := 14\text{m} \quad A_0 := \pi \cdot OD_p \cdot L =$$

$$R := \frac{m_c \cdot C_{pc}}{m_h \cdot C_{ph}} =$$

$$E_{\text{cou}} := \exp\left[U_0 \cdot A_0 \cdot \frac{(R-1)}{m_c \cdot C_{pc}}\right] =$$

$$U_0 \cdot A_0 = \frac{J}{\text{hr} \cdot \text{K}}$$

$$T_2 := \frac{T_1 \cdot (R-1) - R \cdot t_1 \cdot (1 - E_{\text{cou}})}{R \cdot E_{\text{cou}} - 1} =$$

$$t_2 := t_1 + \frac{T_1 - T_2}{R} =$$

K. Log Mean Temperature Difference

$$\text{LMTD}_{\text{cou}} := \frac{(T_1 - t_2) - (T_2 - t_1)}{\ln\left[\frac{(T_1 - t_2)}{(T_2 - t_1)}\right]} =$$

L. Heat Balance

$$q_h := m_h \cdot C_{ph} \cdot (T_1 - T_2) =$$

$$q_c := m_c \cdot C_{pc} \cdot (t_2 - t_1) =$$

$$q := U_0 \cdot A_0 \cdot \text{LMTD}_{\text{cou}} =$$

M. Fouling Factors

$$R_{di} := 0.0005 \frac{\text{m}^2 \cdot \text{K}}{\text{W}} \quad R_{do} := 0.0001 \frac{\text{m}^2 \cdot \text{K}}{\text{W}}$$

$$U := \frac{1}{\frac{1}{U_0} + R_{di} + R_{do}} = \frac{J}{\text{hr} \cdot \text{m}^2 \cdot \text{K}}$$

N. Outlet Temperatures (per fouling factors)

$$L := 14\text{m}$$

$$R := \frac{m_c \cdot C_{pc}}{m_h \cdot C_{ph}} = 3.399 \quad A_0 := \pi \cdot OD_p \cdot L = 2.123\text{m}^2$$

$$E_{\text{cou}} := \exp\left[U \cdot A_0 \cdot \frac{(R-1)}{m_c \cdot C_{pc}}\right] = 1.529 \quad U \cdot A_0 = 5.701 \times 10^6 \cdot \frac{\text{J}}{\text{hr} \cdot \text{K}}$$

$$T_2 := \frac{T_1 \cdot (R-1) - R \cdot t_1 \cdot (1 - E_{\text{cou}})}{R \cdot E_{\text{cou}} - 1} = 303.073\text{K}$$

$$t_2 := t_1 + \frac{T_1 - T_2}{R} = 297.949\text{K}$$

$$q_h := m_h \cdot C_{ph} \cdot (T_1 - T_2) = 1.297 \times 10^4 \text{W}$$

$$q_c := m_c \cdot C_{pc} \cdot (t_2 - t_1) = 1.297 \times 10^4 \text{W}$$

O. Effectiveness

$$m_h \cdot C_{ph} = 2.632 \times 10^3 \frac{\text{m}^2 \cdot \text{kg}}{\text{K} \cdot \text{s}^3}$$

$$m_c \cdot C_{pc} = 8.947 \times 10^3 \frac{\text{m}^2 \cdot \text{kg}}{\text{K} \cdot \text{s}^3}$$

$$q_{\text{max}} := m_h \cdot C_{ph} \cdot (T_1 - t_1) = 3.027 \times 10^4 \cdot \text{W}$$

$$\varepsilon := \frac{q_h}{q_{\text{max}}} = 0.428$$

A.5 Shell and Tube Heat Exchanger

The following analysis shows how the main shell and tube exchanger was evaluated. This met directly follows the one developed in the textbook Design of Thermal Fluid Systems by William S. Janna.

Problem Statement: Manure slurry (properties assumed identical to water) at a temperature of T_1 C and a mass flow 0.63 kg/s is heated in a double pass shell and tube heat exchanger. The manure is the tube fluid, while the shell fluid is water at 53 C and a flowrate of 1.893 kg/s. The exchanger is 7 meters long and 13 inches in diameter. There is only one baffle, and the tubes (nominal 2 inch Sched 40) can be modeled as having 8 tubes doing 2 passes. Determine the outlet temperatures and the efficiency of the exchanger.

Nomenclature:

1. T refers to the temperature of the warmer fluid.
2. t refers to the temperature of the colder fluid
3. h subscript refers to the hotter fluid
4. c subscript refers to the colder fluid
5. s subscript refers to the shell flow area or dimension
6. p subscript refers to the tubular flow area or dimension
7. 1 subscript refers to the inlet condition
8. 2 subscript refers to the outlet condition
9. e subscript refers to the equivalent diameter
10. hy subscript refers to the hydraulic diameter

A. Fluid Properties

Slurry, Tube Fluid

$$m_s := 1.893 \frac{\text{kg}}{\text{s}} = \frac{\text{kg}}{\text{hr}} \quad T_1 := (273 + 53.1)\text{K}$$

$$C_{ps} := 4184 \frac{\text{J}}{\text{kg}\cdot\text{K}} \quad \rho_s := 985 \frac{\text{kg}}{\text{m}^3} \quad Pr_s := 3.02$$

$$v_s := 4.78 \cdot 10^{-7} \frac{\text{m}^2}{\text{s}} \quad k_s := 0.651 \frac{\text{W}}{\text{m}\cdot\text{K}}$$

Water, Shell Fluid

$$m_t := 0.63 \frac{\text{kg}}{\text{s}} = \frac{\text{kg}}{\text{hr}} \quad t_1 := (273 + 15)\text{K}$$

$$C_{pt} := 4181 \frac{\text{J}}{\text{kg}\cdot\text{K}} \quad \rho_t := 1000 \frac{\text{kg}}{\text{m}^3} \quad Pr_t := 7.02$$

$$v_t := 10.06 \cdot 10^{-7} \frac{\text{m}^2}{\text{s}} \quad k_t := 0.597 \frac{\text{W}}{\text{m}\cdot\text{K}}$$

B. Tubing Sizes

$$ID_t := 0.1723\text{ft} \quad OD_t := 0.1979\text{ft} =$$

$$N_t := 8 \quad N_p := 2 \quad L := 7\text{m}$$

C. Shell Data

$$ID_s := 13\text{in} \quad B := 11.5\text{ft} \quad N_b := 1$$

$$P_t := 2.7\text{in} \quad C := P_t - OD_t = 8.26 \times 10^{-3} \text{ m}$$

D. Flow Areas

$$A_t := \frac{N_t \cdot \pi \cdot (ID_t)^2}{4 \cdot N_p} = 8.665 \times 10^{-3} \text{ m}^2 \quad A_s := \frac{ID_s \cdot C \cdot B}{P_t} = 0.139 \text{ m}^2$$

E. Fluid Velocities

$$V_t := \frac{m_t}{\rho_t \cdot A_t} = 0.073 \frac{\text{m}}{\text{s}} \quad V_s := \frac{m_s}{\rho_s \cdot A_s} = 0.014 \frac{\text{m}}{\text{s}}$$

F. Shell Equivalent Diameters

$$D_e := \frac{4 \cdot P_t^2}{\pi \cdot OD_t} - OD_t = 0.039 \text{ m}$$

G. Reynolds Number

$$Re_t := \frac{V_t \cdot ID_t}{\nu_t} = 3.796 \times 10^3 \quad Re_s := \frac{V_s \cdot ID_s}{\nu_s} = 9.523 \times 10^3$$

H. Nusselt Numbers

Modified Dittus-Boelter Equation for Turbulent Flow

$$Nu_t := 0.023 Re_t^{0.8} \cdot Pr_t^{0.4} = 36.618$$

$$Nu_s := 0.36 Re_s^{0.55} \cdot Pr_s^{\frac{1}{3}} = 80.286$$

I. Convection Coefficients

$$h_i := Nu_t \cdot \frac{k_t}{ID_t} = 416.266 \frac{\text{W}}{\text{m}^2 \text{K}} \quad h_i := h_i \cdot \frac{ID_t}{OD_t} = 362.418 \frac{\text{W}}{\text{m}^2 \text{K}}$$

$$h_0 := Nu_s \cdot \frac{k_s}{D_e} = 1.342 \times 10^3 \cdot \frac{\text{W}}{\text{m}^2 \text{K}}$$

J. Exchanger Coefficient

$$U_0 := \frac{1}{\frac{1}{h_t} + \frac{1}{h_0}} = 285.34 \frac{\text{W}}{\text{m}^2\text{K}}$$

K. Outlet Temperature Calculations

$$R := \frac{m_t \cdot C_{pt}}{m_s \cdot C_{ps}} = 0.333 \quad A_0 := N_t \cdot \pi \cdot OD_t \cdot L = 10.612 \text{m}^2$$

$$\frac{U_0 \cdot A_0}{m_t \cdot C_{pt}} = 1.15 \quad U_0 \cdot A_0 = 1.09 \times 10^7 \frac{\text{J}}{\text{hr} \cdot \text{K}}$$

$$S := \frac{\left[e^{\frac{U_0 \cdot A_0}{m_t \cdot C_{pt}} \cdot (R^2 + 1)^{0.5}} - 1 \right]}{e^{\frac{U_0 \cdot A_0}{m_t \cdot C_{pt}} \cdot (R^2 + 1)^{0.5}} \cdot \left[R + 1 + (R^2 + 1)^{0.5} \right] - \left[R + 1 - (R^2 + 1)^{0.5} \right]} = 0.61$$

$$t_2 := S \cdot (T_1 - t_1) + t_1 = 311.23 \text{K}$$

$$T_2 := T_1 - R \cdot (t_2 - t_1) = 318.374 \text{K}$$

L. Log Mean Temperature Difference

$$\text{LMTD} := \frac{(T_1 - t_2) - (T_2 - t_1)}{\ln \left[\frac{(T_1 - t_2)}{(T_2 - t_1)} \right]} = 21.706 \text{K}$$

M. Heat Balance for Fluids

$$q_w := m_s \cdot C_{ps} \cdot (T_1 - T_2) = 6.119 \times 10^4 \text{W}$$

$$q_c := m_t \cdot C_{pt} \cdot (t_1 - t_2) = -6.119 \times 10^4 \text{W}$$

N. Overall Heat Balance for the Exchanger

$$F := \frac{\sqrt{R^2 + 1} \cdot \ln \left[\frac{(1 - S)}{1 - R \cdot S} \right]}{(R - 1) \cdot \ln \left[\frac{\left[2 - S \cdot (R + 1 - \sqrt{R^2 + 1}) \right]}{\left[2 - S \cdot (R + 1 + \sqrt{R^2 + 1}) \right]} \right]} = 0.931$$

$$q := U_0 \cdot A_0 \cdot F \cdot \text{LMTD} = 6.119 \times 10^4 \text{W}$$

O. Fouling Factors and Design Coefficient

$$R_{di} := 0.0005 \frac{\text{m}^2 \cdot \text{K}}{\text{W}} \quad R_{do} := 0.0001 \frac{\text{m}^2 \cdot \text{K}}{\text{W}}$$

$$U := \frac{1}{\frac{1}{U_0} + R_{di} + R_{do}} = 8.771 \times 10^5 \frac{\text{J}}{\text{hr} \cdot \text{m}^2 \cdot \text{K}}$$

P. Outlet Temperatures (per fouling factors)

$$L := 7\text{m} \quad A_0 := N_t \cdot \pi \cdot OD_t \cdot L = 10.612\text{m}^2$$

$$U \cdot A_0 = 9.307 \times 10^6 \frac{\text{J}}{\text{hr} \cdot \text{K}} \quad \frac{U \cdot A_0}{m_t \cdot C_{pt}} = 0.982$$

$$S := \frac{2 \left[e^{\frac{U \cdot A_0}{m_t \cdot C_{pt}} \cdot (R^2 + 1)^{0.5}} - 1 \right]}{e^{\frac{U \cdot A_0}{m_t \cdot C_{pt}} \cdot (R^2 + 1)^{0.5}} \cdot \left[R + 1 + (R^2 + 1)^{0.5} \right] - \left[R + 1 - (R^2 + 1)^{0.5} \right]} = 0.564$$

$$t_2 := S \cdot (T_1 - t_1) + t_1 = 309.47\text{K}$$

$$T_2 := T_1 - R \cdot (t_2 - t_1) = 318.95\text{K}$$

$$q_w := m_s \cdot C_{ps} \cdot (T_1 - T_2) = 5.656 \times 10^4 \text{W}$$

$$q_c := m_t \cdot C_{pt} \cdot (t_1 - t_2) = -5.656 \times 10^4 \text{W}$$

Q. Effectiveness

$$m_t \cdot C_{pt} = 2.634 \times 10^3 \frac{\text{m}^2 \cdot \text{kg}}{\text{K} \cdot \text{s}^3} \quad m_s \cdot C_{ps} = 7.92 \times 10^3 \frac{\text{m}^2 \cdot \text{kg}}{\text{K} \cdot \text{s}^3}$$

$$q_{\max} := m_t \cdot C_{pt} \cdot (T_1 - t_1) = 1.004 \times 10^5 \text{W}$$

$$\varepsilon := \frac{q_w}{q_{\max}} = 0.564$$

APPENDIX B – SDDS DIAGRAM

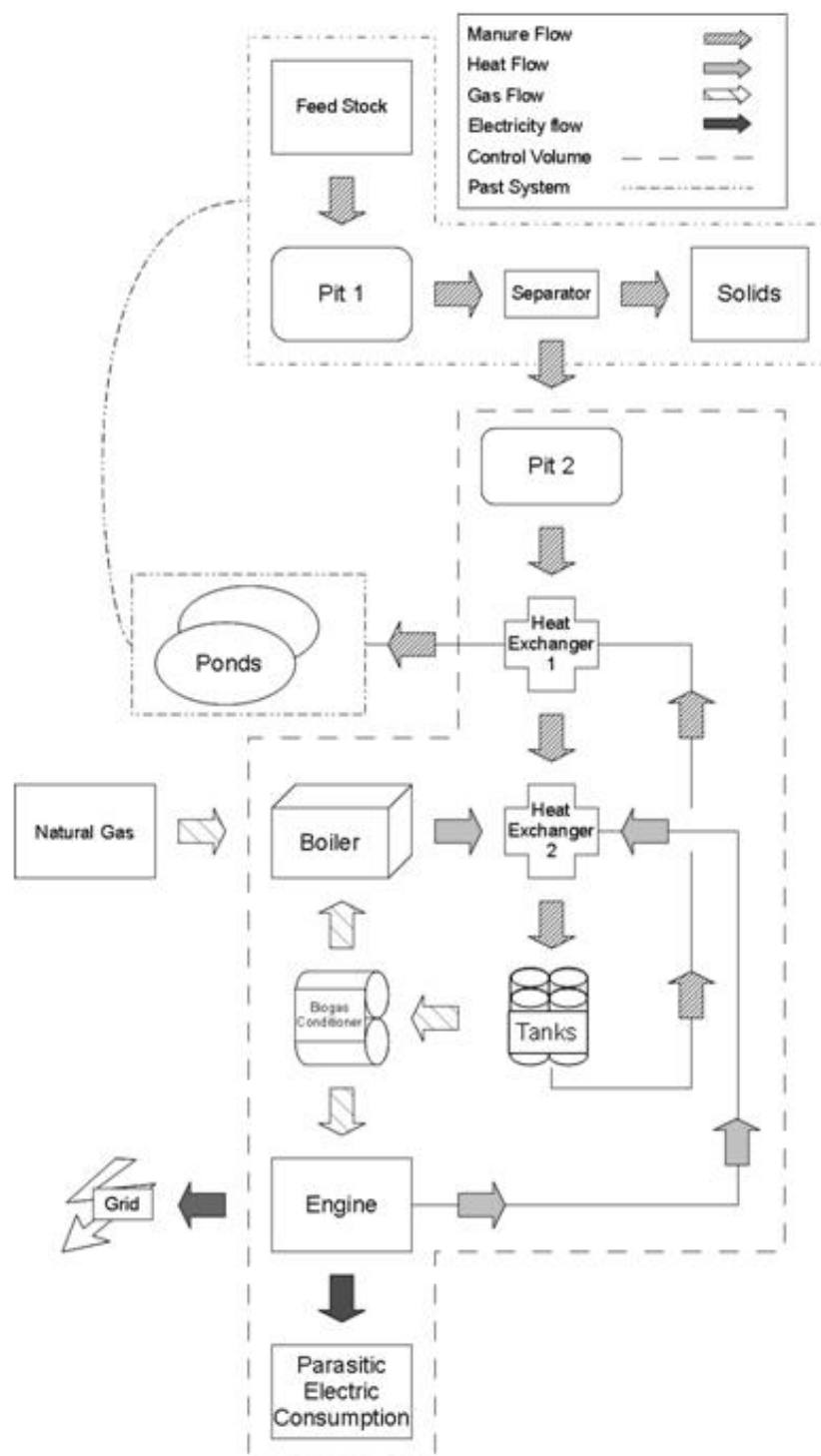

Fig. 25 - SDDS Schematic

APPENDIX C – TRNSYS ANALYSIS

Empirical analysis can be a very powerful tool for steady state and the simplest of transient systems. This approach, however, becomes severely limited when calculations require many iterations. Because of the ever growing computing power and creative programming, transient analysis is becoming much easier. TRNSYS is one of the many programs now available to handle modeling and analysis of complex transient systems. What would have once taken years of research and construction to confirm can now be accomplished with minimal effort and time.

As mentioned in the main report, TRNSYS is a software program that comes with a large library of preprogrammed components. The components represent anything from heat exchangers to engine-generators, and are developed based on the mathematical equations and principals of operation. The components can be linked together to represent a system that can be run over any time period desired. This appendix will discuss the detailed application of TRNSYS and its capabilities to the analysis of SDDS and the research of this thesis.

C.1 Methodology

The first step before starting a simulation was to identify the major elements present in the SDDS and whether or not TRNSYS provided a corresponding component. Each element in the real system was then subjected to a rigorous empirical analysis to quantify the values needed by TRNSYS to accurately model these components. Once the individual components are verified to match the steady state operation of their real world counterparts, they can be combined and connected, similar to the real system, to represent a full system subject to the same physical principals and external factors of the real world. Simulations of the system can be run on any time frame, ranging anywhere from seconds to years if desired. Once the system has been fine-tuned and reaches an acceptable representation of the real system, supplemental empirical analysis can

be used to modify each component to find potential optimizing changes for the system. Because of the rapid simulation (a matter of seconds to simulate an entire year), a modification that would normally take time and money can be analyzed and interpreted in only a matter of minutes.

C.2 Components

Each component is fairly similar in how it is represented in TRNSYS. The user is first asked to define certain parameters that govern the operation of each component. Next, the user defines the inputs to the given component. These inputs can either be set numbers, or results from other components within the system TRNSYS then uses the preprogrammed mathematical approaches to calculate the outputs. Using a simple heat exchanger as an example, a given parameter might be the heat transfer coefficient while the inputs would be temperature and flow rate of each fluid inlet. TRNSYS is then capable of outputting the expected temperatures of the fluids, even if the inlet temperatures are changing continually. The major components used in this specific modeling approach will now be described. If available, excerpts from the TRNSYS documentation is included to supplement component descriptions [10].

C.2.1 *Equation Editor*

One of the most fundamental components available in the TRNSYS library is an equation editor. This component makes it very easy for a user to model anything that may not be readily available in the TRNSYS library. For example, since TRNSYS is mainly used for building modeling and well established energy systems, there is nothing to accurately represent biogas production for a given digester type and operating conditions. The equation modeled was used to include the modified Contois model (presented in Section 2) that defines biogas production rates. Many of the available components frequently presented issues when being linked together into a

whole system, in which case the equation modeler can be used to modify outputs from one unit to fit the needs for inputs of another.

C.2.2 Weather Data Reader

Proforma: Weather Data Reading and Processing\Standard Format\TMY2\Type109-TMY2.tmf
TRNSYS Model: Type 109
This component serves the main purpose of reading weather data at regular time intervals from a data file, converting it to a desired system of units and processing the solar radiation data to obtain tilted surface radiation and angle of incidence for an arbitrary number of surfaces. In this mode, Type 109 reads a weather data file in the standard TMY2 format. The TMY2 format is used by the National Solar Radiation Data Base (USA) but TMY2 files can be generated from many programs, such as Meteonorm.

This component serves the main purpose of reading weather data at regular time intervals from a data file, converting it to a desired system of units and generating direct and diffuse radiation outputs for an arbitrary number of surfaces with arbitrary orientation and inclination.

There are four different modes of weather data format handling:

- a userdefined mode (MODE 1) for arbitrary weather data
- MODE 2 to read in TMY2-data format
- MODE 3 to read in the German TRY-data format
- VDI- MODEs 91x and 92x according to the german standard VDI 2078.

This data reader is also able to read in general data (which may be any kind of data without restriction to weather data), converting it to a desired system of units and making it available to other TRNSYS UNITS as time varying forcing functions.

TYPE 109 uses free-formatted reading for user defined data. Each value must be separated from the previous value by a blank or a comma for MODE 0 or MODE 1.

The form of weather data used in this model is TMY2. The most acceptable data file available comes from a weather station located in Cedar City, Utah. While several hundred miles away from the SDDS location, similar elevations and geography lead to the assumption that the weather for the two locations is comparable.

C.2.3 Building

Proforma: Loads and Structures\Single Zone Models\Lumped Capacitance Building (Type 88)\Type88.tmf
TRNSYS Model: Type 88
This component models a simple lumped capacitance single zone structure subject to internal gains. It differs from the Type12 simple building model in that it makes no assumption about the control scheme. Furthermore, it neglects solar gains and assumes an overall U value for the entire structure. Its usefulness comes from the speed with which a building heating and/or cooling load can be added to a system simulation.

This component models a simple lumped capacitance single zone structure subject to internal gains. It differs from the Type12 simple building model in that it makes no assumption about the control scheme. Furthermore, it neglects solar gains and assumes an overall U value for the entire structure. Its usefulness comes from the speed with which a building heating and/or cooling load can be added to a system simulation.

Nomenclature

U	building loss coefficient (kJ/hr-m ² -C)
Cap	building capacitance (kJ/C)
Cp _{air}	specific heat of building air (kJ/kg-C)
ρ _{air}	density of building air (kg/m ³)
Area	building surface area (m ²)
Vol	building volume (m ³)
ω _{mult}	humidity ratio multiplier (-)
T _{initial}	initial temperature (C)
ω _{initial}	initial humidity ratio (-)
h _{fg}	latent heat of vaporization (kJ/kg)
T _{vent}	temperature of ventilation air (C)
ω _{vent}	humidity ratio of ventilation air (-)
m _{vent}	ventilation air mass flow rate (kg/hr)
T _{amb}	ambient temperature (C)
ω _{amb}	ambient humidity ratio (-)
m _{inf}	mass flow rate of infiltration air (kg/hr)
Q _{lights}	rate of energy gain from lights (kJ/hr)
Q _{equip}	rate of energy gain from equipment (kJ/hr)

Q_{peop}	rate of sensible energy gain from people (kJ/hr)
ω_{gain}	rate of humidity gain (kg/hr)
T_{zone}	zone temperature (C)
ω_{zone}	zone humidity ratio (-)
\dot{m}_{vent}	mass flow rate of ventilation air (kg/hr)
\dot{m}_{infil}	mass flow rate of infiltration air (kg/hr)
Q_{infil_s}	sensible energy gain from infiltration (kJ/hr)
Q_{infil_l}	latent energy gain from infiltration (kJ/hr)
Q_{vent_s}	sensible energy gain from ventilation (kJ/hr)
Q_{vent_l}	latent energy gain from ventilation (kJ/hr)

Mathematical Description

The component is governed by two balance equations. An energy balance that predicts the zone temperature and a moisture balance that predicts the humidity content of the zone.

The energy balance for the zone is:

$$\frac{dT}{dt} = \frac{UA}{cap}(T_{amb} - T) + \frac{\dot{m}_{vent} C_{p,air}}{cap}(T_{vent} - T) + \frac{\dot{m}_{infil} C_{p,air}}{cap}(T_{infil} - T) + \sum Q_{gains}$$

with internal sensible gains coming from people, equipment and lights.

The moisture balance equation is similar in form to the energy balance:

$$\frac{d\omega}{dt} = \frac{\dot{m}_{infil}}{\rho V}(\omega_{infil} - \omega) + \frac{\dot{m}_{vent}}{\rho V}(\omega_{vent} - \omega) + \frac{\sum \omega_{gains}}{\rho V}$$

with internal moisture gains coming from people and equipment.

C.2.4 Tanks

Proforma: Thermal Storage\Stratified Storage Tank\Fixed Inlets\Uniform Losses\Type4a.tmf
TRNSYS Model: Type 4
The thermal performance of a fluid-filled sensible energy storage tank, subject to thermal stratification, can be modelled by assuming that the tank consists of N ($N \leq 15$) fully-mixed equal volume segments. The degree of stratification is determined by the value of N. If N is equal to 1, the storage tank is modelled as a fully-mixed tank and no stratification effects are possible. This instance of Type 4 models a stratified tank having fixed inlet positions defined within the code. Fluid entering the hot side of the tank is added to the tank node below the first auxiliary heater. Fluid entering the cold side of the tank enters the bottom node. The node sizes in this instance need not be equal. Temperature deadband on heater thermostats are available. This instance further assumes that losses from each tank node are equal and does not compute losses to the gas flue of the auxiliary heater.

The thermal performance of a fluid-filled sensible energy storage tank, subject to thermal stratification, can be modeled by assuming that the tank consists of N ($N \leq 15$) fully-mixed equal volume segments, as shown in Figure 5.12.1-1. The degree of stratification is determined by the value of N. If N is equal to 1, the storage tank is modeled as a fully-mixed tank and no stratification effects are possible. Options of fixed or variable inlets, unequal size nodes, temperature deadband on heater thermostats, incremental loss coefficients, and losses to gas flue of auxiliary heater are all available.

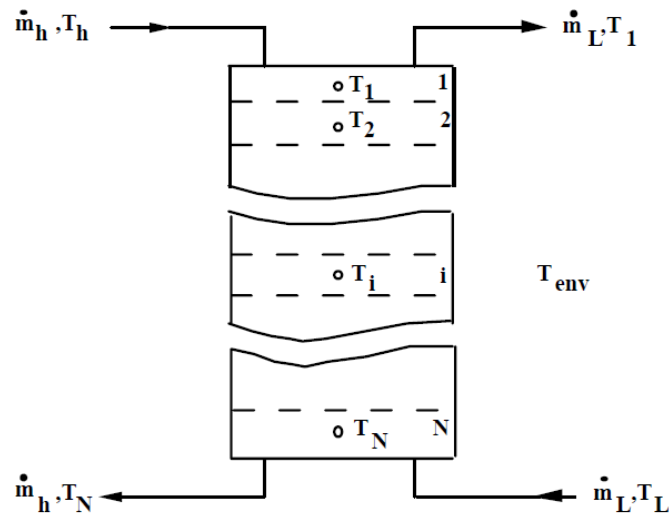

Nomenclature

A_i	surface area of the i th tank segment
C_{pf}	specific heat of the tank fluid
H_i	height of i th segment
i	tank segment with the top (hottest) segment having $i = 1$
l_1	number of the tank segment in which the first heater is located $1 \leq l \leq N$
l_2	number of the tank segment in which the second heater is located $1 \leq l \leq N$
IN_1	node position of entering flow from heat source $1 \leq l_T \leq N$
IN_2	node position of return flow from load $1 \leq l_T \leq N$
$l_{T,1}$	number of the tank segment in which the thermostat of the first heater is located $1 \leq l_{T,1} \leq N$
$l_{T,2}$	number of the tank segment in which the second heater thermostat is located $1 \leq l_{T,2} \leq N$
M_i	mass of fluid in the i th section
\dot{m}_L	fluid mass flow rate to the load and/or of the makeup fluid
\dot{m}_h	fluid mass flow rate to tank from the heat source
N	number of fully mixed (uniform temperature) tank segments ($N \leq 15$)
\dot{Q}_{aux}	total rate of energy input by the heater
$\dot{Q}_{aux,1}$	rate of energy input by the first auxiliary heater
$\dot{Q}_{aux,2}$	rate of energy input by the second auxiliary heater
\dot{Q}_{env}	rate of energy loss from the tank to the surroundings, including boiling effects if applicable
$\dot{Q}_{HE,1}$	maximum rate of energy input by the first heater
$\dot{Q}_{HE,2}$	maximum rate of energy input by the second heater
\dot{Q}_i	rate of energy input by the heating element to the i th segment
\dot{Q}_{in}	rate of energy input to tank from hot fluid stream
\dot{Q}_{rec}	the rate of energy input by the heater necessary for all segments $i \leq l$ to be raised to the set temperature
\dot{Q}_s	rate at which sensible energy is removed from the tank to supply the load
S_h	number of the tank segment to which the fluid from the heat source enters $1 \leq S_h \leq N$
S_L	number of the tank segment to which the fluid replacing that extracted to supply the load enters $1 \leq S_L \leq N$
t	time
\bar{T}	average storage temperature

T_{env}	temperature of the environment surrounding the tank
T_i	temperature of the i th tank segment
T_f	average temperature of exhaust flue when heater is not operating
T_h	temperature of the fluid entering the storage tank from the heat source
T_L	temperature of the fluid replacing that extracted to supply the load
$T_{set,1}$	set temperature of the first heater thermostat
$T_{set,2}$	set temperature of the second heater thermostat
U_t	loss coefficient between the tank and its environment (per unit area)
ΔU_i	incremental loss coefficient between the i th tank node and its environment (per unit area)
$(UA)_f$	total conductance for heat loss to gas flue when auxiliary heater is not operating
$(UA)_{f,i}$	conductance for heat loss to gas flue for node i
V_t	tank volume
ΔE	internal energy change of the tank
$\Delta T_{db,1}$	first thermostat temperature deadband. Heater turns on when $T_{IT1} = (T_{set,1} - \Delta T_{db,1})$ and stays on until $T_{IT1} = T_{set,1}$
$\Delta T_{db,2}$	second thermostat temperature deadband. Heater turns on when $T_{IT2} = (T_{set,2} - \Delta T_{db,2})$ and stays on until $T_{IT2} = T_{set,2}$
α_i	a control function defined by $\alpha_i = 1$ if $i = S_h$; 0 otherwise
β_i	a control function defined by $\beta_i = 1$ if $i = S_L$; 0 otherwise
γ_i	a control function defined by $\gamma_i = \dot{m}_h \sum_{j=1}^{i-1} \alpha_j - \dot{m}_L \sum_{j=i+1}^N \beta_j$
γ_f	a control function that defines if the auxiliary heater is off or on. 1 is off, 0 is on
γ_{htr}	an optional control function input (0 or 1) that disables or enables the internal auxiliary heater
ρ_f	fluid density

Mathematical Description

To make it simple to change the number of nodes, tank component locations are entered as heights, measured from the floor up, rather than node numbers. These components include: inlet and outlet flows, auxiliary heaters, thermostats, and heat exchangers.

There are two **inlet modes** available. In mode 1, the flow stream enters the node that is closest to it in temperature. With sufficient nodes, this permits a maximum degree of stratification. In mode 2, flow streams enter the tank at fixed positions, as specified by the user. At the end of each time interval, any temperature inversions that exist are eliminated by mixing of the appropriate adjacent nodes.

The **user may specify the height of each node** using the last set parameters. Optionally, equal size nodes may be specified quite simply by setting parameter 31 to zero. The model will automatically divide the tank into equal segments. In this case, no additional node size specifications are required.

The **volume of the tank** used by the model is assumed to be the actual volume of the tank. A 300-liter hot water heater does not necessarily hold 300 liters of water.

ENERGY BALANCE

An energy balance written about the i^{th} tank segment is expressed as:

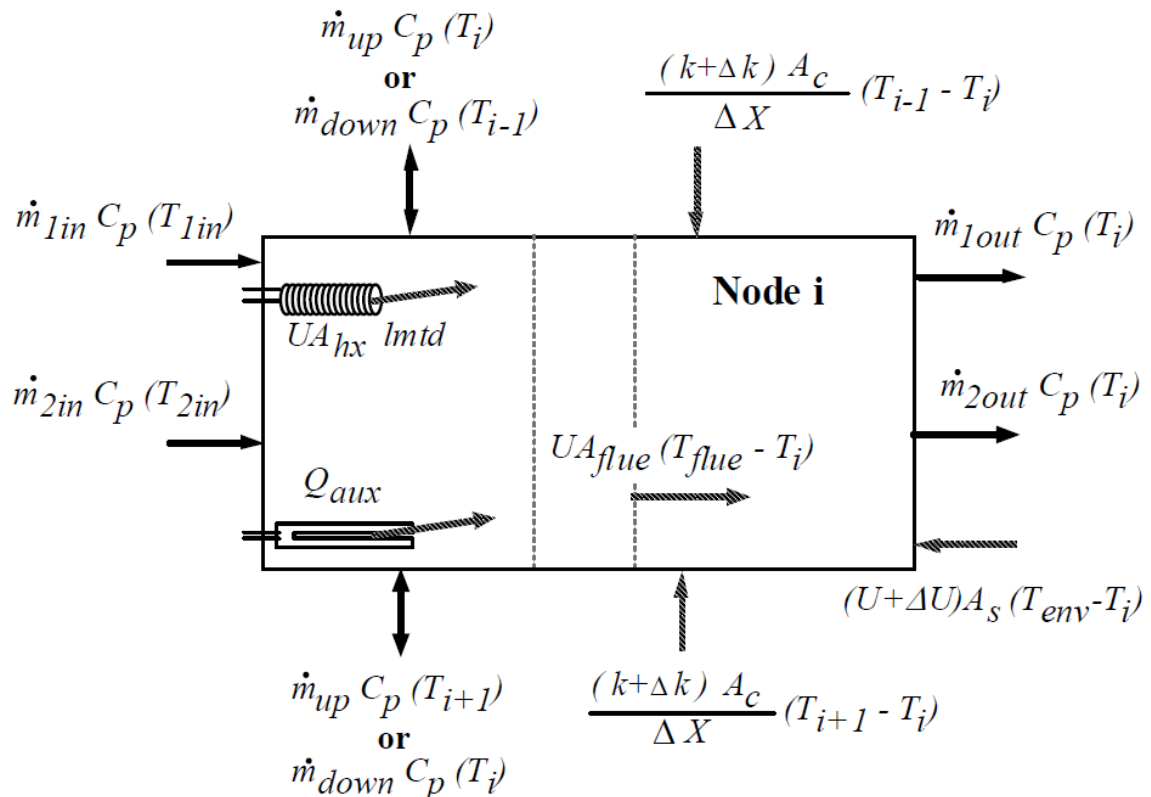

Combining all energy flows into one equation, the differential equation for the temperature of node i is expressed as:

$$\begin{aligned}
 (M_i C_p) \frac{dT_i}{dt} = & \frac{(k + \Delta k) A_{c,i}}{\Delta X_{i+1 \rightarrow i}} (T_{i+1} - T_i) \\
 & + \frac{(k + \Delta k) A_{c,i}}{\Delta X_{i-1 \rightarrow i}} (T_{i-1} - T_i) + (U_{\text{tank}} + \Delta U_i) A_{s,i} (T_{\text{env}} - T_i) \\
 & + UA_{\text{flue},i} (T_{\text{flue}} - T_i) + \dot{m}_{\text{down}} C_p (T_{i-1}) - \dot{m}_{\text{up}} C_p (T_i) \\
 & - \dot{m}_{\text{down}} C_p (T_i) - \dot{m}_{\text{up}} C_p (T_{i+1}) + \gamma_{\text{htr1}} \dot{Q}_{\text{aux1}} + \gamma_{\text{htr2}} \dot{Q}_{\text{aux2}} \\
 & + UA_{\text{hx1}} (\text{lmtd}_1) + UA_{\text{hx2}} (\text{lmtd}_2) + UA_{\text{hx3}} (\text{lmtd}_3) \\
 & + \dot{m}_{1\text{in}} C_p T_{1\text{in}} - \dot{m}_{1\text{out}} C_p T_i + \dot{m}_{2\text{in}} T_{2\text{in}} - \dot{m}_{2\text{out}} C_p T_i
 \end{aligned}$$

The thermal storage tank component is used to model several different elements of the SDDS. First, it models the operation of the four large digester tanks. These tanks receive inlet fluid from the main heat exchanger and are housed in the building. The overall heat transfer coefficient is applied to determine how the building temperature affects tank heat loss. The next application of this component is for the thermal storage tank used in the heat loop at SDDS. This tank volume is defined to appropriately add capacitance to the heat loop. Finally, this component is used to model the characteristics of the outdoor manure pit. Weather data is applied to the tank to determine the manure pit temperature trends.

C.2.5 Heating and Cooling

Proforma: HVAC\Auxiliary Heaters\Type6.tmf
TRNSYS Model: Type 6
An auxiliary heater is modeled to elevate the temperature of a flowstream using either internal control, external control or a combination of both types of control. The heater is designed to add heat to the flowstream at a user-designated rate (\dot{Q}_{max}) whenever the external control input is equal to one and the heater outlet temperature is less than a user-specified maximum (T_{set}). By specifying a constant value of the control function of one and specifying a sufficiently large value of \dot{Q}_{max} , this routine will perform like a domestic hot water auxiliary with internal control to maintain an outlet temperature of T_{set} . By providing a control function of zero or one from a thermostat or controller, this routine will perform like a furnace adding heat at a rate of \dot{Q}_{max} but not exceeding an outlet temperature of T_{set} . In this application, a constant outlet temperature is not sought and T_{set} may be thought of as an arbitrary safety limit.

An auxiliary heater is modeled to elevate the temperature of a flowstream using either internal control, external control or a combination of both. The heater is designed to add heat to the flowstream at a rate less than or equal to \dot{Q}_{max} , which is a user determined quantity, whenever the control function γ is equal to 1 and the outlet temperature is less than the setpoint T_{set} .

By specifying a constant value of γ equal to 1 and a sufficiently large value for \dot{Q}_{max} , Type 6 will perform like a domestic hot water auxiliary heater with internal control to maintain an outlet temperature of T_{set} .

By providing a control function of 0 or 1 and setting T_{set} to a very high value with a reasonably low value of \dot{Q}_{max} , Type 6 will perform like an externally controlled ON/OFF heating device.

Users should be aware that the maximum thermal energy transfer to the flowstream is not \dot{Q}_{max} but $\eta_{htr} * \dot{Q}_{max}$.

Nomenclature

C_{pf}	[kJ/kg.K]	fluid specific heat
\dot{m}_i	[kg/hr]	inlet fluid mass flow rate
\dot{m}_o	[kg/hr]	outlet fluid mass flow rate
\dot{Q}_{aux}	[kJ/hr]	required heating rate including efficiency effects
\dot{Q}_{fluid}	[kJ/hr]	rate of heat addition to fluid stream
\dot{Q}_{loss}	[kJ/hr]	rate of thermal losses from heater to environment
\dot{Q}_{max}	[kJ/hr]	maximum heating rate of heater
T_{env}	[C]	temperature of heater surroundings for loss calculations
T_i	[C]	fluid inlet temperature
T_o	[C]	fluid outlet temperature
T_{set}	[C]	set temperature of heater internal thermostat
UA	[kJ/hr]	overall loss coefficient between the heater and its surroundings during operation
γ	[-]	external control function which has values of 0 or 1
η_{htr}	[0..1]	efficiency of auxiliary heater

Mathematical Description

If $T_i \geq T_{set}$, $\dot{m}_i \leq 0$, or $\gamma = 0$ then

$$T_o = T_i, \dot{m}_o = \dot{m}_i, \dot{Q}_{loss} = 0, \dot{Q}_{fluid} = 0, \text{ and } \dot{Q}_{aux} = 0$$

Otherwise, an energy balance on the steady-state heater reveals:

$$T_o = \frac{\dot{Q}_{max} \eta_{htr} + \dot{m} C_{pf} T_i + UA T_{env} - \frac{UA T_i}{2}}{\dot{m} C_{pf} + \frac{UA}{2}}$$

$$\dot{m}_o = \dot{m}_i$$

$$\dot{Q}_{aux} = \dot{Q}_{max}$$

$$\dot{Q}_{fluid} = \dot{m}_o C_{pf} (T_o - T_i)$$

$$\bar{T} = \frac{(T_o + T_{in})}{2}$$

$$\dot{Q}_{loss} = UA (\bar{T} - T_{env}) + (1 - \eta_{htr}) \dot{Q}_{max}$$

Unless $T_o > T_{set}$, then

$$T_o = T_{set},$$

$$m_o = m_i,$$

$$\dot{Q}_{fluid} = \dot{m}_o C_{pf} (T_{set} - T_j)$$

$$\bar{T} = \frac{(T_{set} + T_{in})}{2}$$

$$\dot{Q}_{aux} = \frac{\dot{m} C_{pf} (T_{set} - T_j) + UA (\bar{T} - T_{env})}{\eta_{htr}}$$

where: $\dot{Q}_{aux} = \dot{Q}_{loss} + \dot{Q}_{fluid}$

While this component is included in the computer model, it is not currently used. It is included to mimic the potential heat addition from the additional boilers installed at SDDS.

Because those boilers are not used, this auxiliary heating component is set to a control function of 0, in other words it is off.

Proforma: HVAC\Auxiliary Cooling Unit\Type92.tmf
TRNSYS Model: Type 92
<p>An auxiliary cooling device is modeled to reduce the temperature of a flowstream using either internal control, external control or a combination of both types of control. The cooling device is designed to remove energy from the flowstream at a user-designated rate (\dot{Q}_{max}) whenever the external control input is equal to one and the cooling device outlet temperature is less than a user-specified maximum (T_{set}).</p> <p>By specifying a constant value of the control function of one and specifying a sufficiently large value of \dot{Q}_{max}, this routine will perform like a domestic cold water auxiliary with internal control to maintain an outlet temperature of T_{set}.</p> <p>By providing a control function of zero or one from a thermostat or controller, this routine will perform like a device removing energy at a rate of \dot{Q}_{max} but not dropping below an outlet temperature of T_{set}. In this application, a constant outlet temperature is not sought and T_{set} may be thought of as an arbitrary safety limit.</p>

Instead of adding heat to a flow stream, the auxiliary cooling device removes heat. Like Type 6, the cooler is designed to remove heat from the flow stream at a user determined rate, \dot{Q}_{max} , whenever the external control Input, γ is equal to 1 and the cooling unit outlet temperature is greater than a user specified minimum, T_{set} .

Nomenclature

C_{pf}	[kJ/kg.K]	fluid specific heat
\dot{m}_i	[kg/hr]	inlet fluid mass flow rate
\dot{m}_o	[kg/hr]	outlet fluid mass flow rate
\dot{Q}_{aux}	[kJ/hr]	required heating rate including efficiency effects
\dot{Q}_{fluid}	[kJ/hr]	rate of heat addition to fluid stream
\dot{Q}_{loss}	[kJ/hr]	rate of thermal losses from heater to environment
\dot{Q}_{max}	[kJ/hr]	maximum heating rate of heater
T_{env}	[C]	temperature of heater surroundings for loss calculations
T_i	[C]	fluid inlet temperature
T_o	[C]	fluid outlet temperature
T_{set}	[C]	set temperature of heater internal thermostat
UA	[kJ/hr]	overall loss coefficient between the heater and its surroundings during operation
γ	[-]	external control function which has values of 0 or 1
η_{htr}	[0..1]	efficiency of auxiliary heater

Mathematical Description

If $T_i \leq T_{\text{set}}$, $\dot{m}_i \leq 0$, or $\gamma = 0$ then

$$T_o = T_i, \dot{m}_o = \dot{m}_i, \dot{Q}_{\text{loss}} = 0, \dot{Q}_{\text{fluid}} = 0, \text{ and } \dot{Q}_{\text{aux}} = 0$$

Otherwise, an energy balance on the steady-state cooling device reveals:

$$T_o = \frac{\dot{Q}_{\text{max}} \eta_{\text{htr}} + \dot{m} C_{\text{pf}} T_i + UA T_{\text{env}} - \frac{UA T_i}{2}}{\dot{m} C_{\text{pf}} + \frac{UA}{2}}$$

$$\dot{m}_o = \dot{m}_i$$

$$\dot{Q}_{\text{aux}} = \dot{Q}_{\text{max}}$$

$$\dot{Q}_{\text{fluid}} = \dot{m}_o C_{\text{pf}} (T_i - T_o)$$

$$\bar{T} = \frac{(T_o + T_{\text{in}})}{2}$$

$$\dot{Q}_{\text{loss}} = UA (\bar{T} - T_{\text{env}}) + (1 - \eta_{\text{htr}}) \dot{Q}_{\text{max}}$$

Unless $T_o < T_{\text{set}}$, then

$$T_o = T_{\text{set}}$$

$$\dot{m}_o = \dot{m}_i,$$

$$\dot{Q}_{\text{fluid}} = \dot{m}_o C_{\text{pf}} (T_{\text{set}} - T_i)$$

$$\bar{T} = \frac{(T_{\text{set}} + T_{\text{in}})}{2}$$

$$\dot{Q}_{\text{loss}} = UA (\bar{T} - T_{\text{env}}) + (1 - \eta_{\text{htr}}) \dot{Q}_{\text{max}}$$

$$\dot{Q}_{\text{aux}} = \frac{\dot{m} C_{\text{pf}} (T_{\text{set}} - T_{\text{j}}) + UA (\bar{T} - T_{\text{env}})}{\eta_{\text{htr}}}$$

where: $\dot{Q}_{\text{aux}} = \dot{Q}_{\text{loss}} + \dot{Q}_{\text{fluid}}$

This auxiliary chilling component is included to imitate the supplemental engine heat radiator at SDDS. Especially in the summer months, there are times where the digester temperatures climb over 40 °C. Because biogas production is hindered at higher temperatures, the supplemental engine radiator can be used to reduce the temperature of the heat loop by dumping heat outside of the building. The cooling rate of the radiator is assumed to be capable of cooling all heat that may come from the engine block, equivalent to the maximum power output of the engine-generator of 75 kW. There is also another auxiliary chilling unit included to act as the biogas condenser. The inlet temperature and flowrates are taken from other components in the simulation, and a desired set point temperature is defined. The simulation can then calculate the required cooling rate to chill the biogas to the defined temperature.

C.2.6 Heat Exchangers

COUNTER FLOW

Proforma: Heat Exchangers\Counter Flow\Type5b.tmf

TRNSYS Model: Type 5

A zero capacitance sensible heat exchanger is modelled in various configurations. In this instance, a counter flow heat exchanger is modeled. Given the hot and cold side inlet temperatures and flow rates, the effectiveness is calculated for a given fixed value of the overall heat transfer coefficient.

SHELL AND TUBE

Proforma: Heat Exchangers\Shell and Tube\Type5g.tmf

TRNSYS Model: Type 5

A zero capacitance sensible heat exchanger is modelled in various configurations. In this instance a shell and tube device is modeled. Given the hot and cold side inlet temperatures and flow rates, the effectiveness is calculated for a given fixed value of the overall heat transfer coefficient.

A zero capacitance sensible heat exchanger is modeled in the parallel, counter, various cross flow configurations and shell and tube modes. For all modes, given the hot and cold side inlet temperatures and flow rates, the effectiveness is calculated for a given fixed value of the overall heat transfer coefficient. The cross flow modes assume one of the following.

1. That the hot (source) side fluid is unmixed while the cold (load) side is completely mixed
2. That the cold (load) side fluid is unmixed while the hot (source) side is completely mixed
3. That neither the cold nor the hot side fluids are mixed or
4. That both the hot and cold sides are mixed.

The mathematical description that follows is covered in detail in Kays and London (1). The shell and tube model and the situation in which both fluids are unmixed are covered in DeWitt and Incropera (2). Type 91 models a constant effectiveness heat exchanger in which UA is calculated instead of being provided as an Input.

Nomenclature

C_c	capacity rate of fluid on cold side, $\dot{m}_c C_{pc}$
C_h	capacity rate of fluid on hot side, $\dot{m}_h C_{ph}$
C_{max}	maximum capacity rate
C_{min}	minimum capacity rate
C_{pc}	specific heat of cold side fluid
C_{ph}	specific heat of hot side fluid
ε	heat exchanger effectiveness
\dot{m}_c	fluid mass flow rate on cold side
\dot{m}_h	fluid mass flow rate on hot side
\dot{Q}_T	total heat transfer rate across heat exchanger
\dot{Q}_{max}	the maximum heat transfer rate across exchanger
T_{ci}	cold side inlet temperature
T_{co}	cold side outlet temperature
T_{hi}	hot side inlet temperature
T_{ho}	hot side outlet temperature
UA	overall heat transfer coefficient of exchanger
N	number of shell passes

Mathematical Description

$$C_c = \dot{m}_c C_{pc}$$

$$C_h = \dot{m}_h C_{ph}$$

$$C_{max} = \text{maximum value of } C_h \text{ and } C_c$$

$$C_{min} = \text{minimum value of } C_h \text{ and } C_c$$

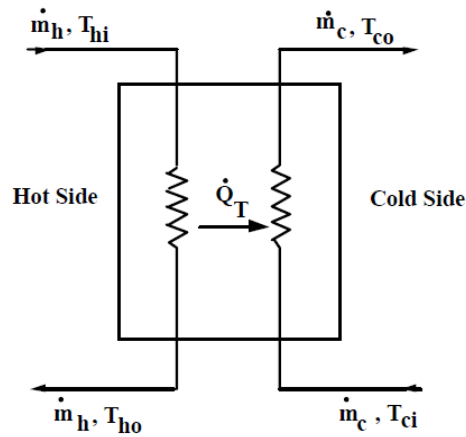

MODE 2 – COUNTER FLOW

$$\varepsilon = \frac{1 - \exp\left(-\frac{UA}{C_{\min}}\left(1 - \frac{C_{\min}}{C_{\max}}\right)\right)}{1 - \left(\frac{C_{\min}}{C_{\max}}\right) \exp\left(-\frac{UA}{C_{\min}}\left(1 - \frac{C_{\min}}{C_{\max}}\right)\right)}$$

MODE 7 – SHELL AND TUBE

$$\varepsilon_1 = 2 \left\{ 1 + \frac{C_{\min}}{C_{\max}} + \left(1 + \left(\frac{C_{\min}}{C_{\max}}\right)^2\right)^{0.5} * \frac{1 + \exp\left[-\frac{UA}{C_{\min}}\left(1 + \left(\frac{C_{\min}}{C_{\max}}\right)^2\right)^{0.5}\right]}{1 - \exp\left[-\frac{UA}{C_{\min}}\left(1 + \left(\frac{C_{\min}}{C_{\max}}\right)^2\right)^{0.5}\right]} \right\}^{-1}$$

$$\varepsilon = \left[\left(\frac{1 - \varepsilon_1 \frac{C_{\min}}{C_{\max}}}{1 - \varepsilon_1} \right)^N - 1 \right] \left[\left(\frac{1 - \varepsilon_1 \frac{C_{\min}}{C_{\max}}}{1 - \varepsilon_1} \right)^N - \frac{C_{\min}}{C_{\max}} \right]^{-1}$$

ALL MODES

$$T_{ho} = T_{hi} - \varepsilon \left(\frac{C_{\min}}{C_h}\right) (T_{hi} - T_{ci})$$

$$\dot{Q}_T = \varepsilon C_{\min} (T_{hi} - T_{ci})$$

The two types of heat exchangers used in the main computer simulation are a counterflow tube in tube and a shell and tube (the main shell and tube exchanger as well as the exhaust heat exchanger).

C.2.7 Engine-Generator

Proforma: Electrical\Diesel Engine (DEGS)\Generic Model\Type120a.tmf
TRNSYS Model: Type 120
<p>TYPE120 is a mathematical model for a diesel engine generator set (DEGS). The model is based on an empirical relation (1st order polynomial) for the fuel consumption expressed as a function of the electrical power output (normalized). Electrical and fuel efficiencies are both calculated. In this instance, Type120 is used to predict the performance of a generic DEGS in the power range 5-500 kW. The generic model extrapolates from a reference fuel efficiency curve (average of 5 different DEGS). The generic model incorporates a correction factor derived from actual data measurements on DEGS for 20 remote area power systems (RAPS) with average operating powers in the range 5-186 kW (Lloyd, 1999). The default fuel is diesel (liquid), but a database with fuel properties (Adler et al., 1986; McCarthy, 1982) included in TYPE120 make it possible to calculate the equivalent fuel flow rates (liquid or gas) for 5 alternative fuels: liquefied gas (LPG), propane (C3H8), methane (CH4), natural gas, or hydrogen (H2).</p>

Type 120 is a mathematical model for a diesel engine generator set (DEGS). The model is based on an empirical relation (1st order polynomial) for the fuel consumption expressed as a function of the electrical power output (normalized). Electrical and fuel efficiencies are both calculated. The model can simulate a number of identical DEGS units.

Type 120 can be used to predict the performance of a specific DEGS, provided a fuel consumption curve is supplied. Alternatively, a generic model can be used to predict the performance of any DEGS in the power range 5-500 kW.

The generic model extrapolates from a reference fuel efficiency curve (average of 5 different DEGS). The generic model incorporates a correction factor derived from actual data measurements on DEGS for 20 remote area power systems (RAPS) with average operating powers in the range 5-186 kW [1].

The default fuel is diesel (liquid), but a database with fuel properties [2,3] included in Type 120 make it possible to calculate the equivalent fuel flow rates (liquid or gas) for 5 alternative fuels: liquefied gas (LPG), propane (C3H8), methane (CH4), natural gas, or hydrogen (H2). In the following, "diesel" is used to refer to the fuel.

Nomenclature

P_{DEGS}	[W]	DEGS Rated Electrical Power
$P_{\text{DEGS, rated}}$	[W]	DEGS Rated Electrical Power
N_{DEGS}	[-]	Number of identical DEGS units
X	[-]	Normalized power
\dot{V}	[m ³ /s]	Fuel volumetric flowrate
ρ	[kg/m ³]	Fuel density
LHV	[J/kg]	Lower Heating Value of the fuel

Mathematical Description

The normalized power is defined as:

$$X = P_{\text{DEGS}} / P_{\text{DEGS, rated}}$$

The electrical efficiency is:

$$\eta_{\text{el}} = \frac{P_{\text{DEGS}}}{\rho_{\text{diesel}} \cdot \dot{V}_{\text{diesel}} \cdot \text{LHV}_{\text{diesel}}}$$

The Total Power output is:

$$P_{\text{total}} = N_{\text{DEGS}} P_{\text{DEGS}}$$

The fuel consumption is given as a curve fit:

$$\dot{V}_{\text{diesel}} = a + b \cdot X$$

The fuel efficiency is:

$$\eta_{\text{fuel}} = \frac{P_{\text{DEGS}}}{\dot{V}_{\text{diesel}}}$$

And the total fuel consumption is:

$$\dot{V}_{\text{total}} = N_{\text{DEGS}} \dot{V}_{\text{diesel}}$$

Total Thermal losses (wasted energy):

$$Q_{\text{waste}} = N_{\text{DEGS}} P_{\text{DEGS}} (100 - \eta_{\text{el}}) / \eta_{\text{el}}$$

This component represents the operation of the biogas engine-generator installed at SDDS.

The power output of this component is defined by the biogas production rate combined with the

lower heating value of the gas and the efficiency of the engine (assumed to be 33%). Of the waste heat output of the engine, 40% is assumed to go to the exhaust, 40% is transferred through the engine block to the heat loop, and the final 20% is added to the building zone as a sensible energy gain.

C.2.8 Controllers

Proforma: Controllers\Differential Controller w_ Hysteresis\for Temperatures\Solver 0 (Successive Substitution) Control Strategy\Type2b.tmf

TRNSYS Model: Type 2

The on/off differential controller generates a control function which can have a value of 1 or 0. The value of the control signal is chosen as a function of the difference between upper and lower temperatures T_H and T_L , compared with two dead band temperature differences DT_H and DT_L . The new value of the control function depends on the value of the input control function at the previous timestep. The controller is normally used with the input control signal connected to the output control signal, providing a hysteresis effect. However, control signals from different components may be used as the input control signal for this component if a more detailed form of hysteresis is desired.

For safety considerations, a high limit cut-out is included with this controller. Regardless of the dead band conditions, the control function will be set to zero if the high limit condition is exceeded. This controller is not restricted to sensing temperatures, even though temperature notation is used. This controller instance uses unit descriptions of degC so that it is readily usable as a thermostatic differential controller.

This instance of the Type2 controller is intended for use with the standard TRNSYS SOLVER 0 (Successive Substitution)

This controller generates a control function γ_o that can have values of 0 or 1. The value of γ_o is chosen as a function of the difference between upper and lower temperatures, T_H and T_L , compared with two dead band temperature differences, ΔT_H and ΔT_L . The new value of γ_o is dependent on whether $\gamma_i = 0$ or 1. The controller is normally used with γ_o connected to γ_i giving a hysteresis effect. For safety considerations, a high limit cut-out is included with the TYPE 2 controller. Regardless of the dead band conditions, the control function will be set to zero if the high limit condition is exceeded. Note that this controller is not restricted to sensing temperatures, even though temperature notation is used throughout the documentation.

Nomenclature

ΔT_H	[C]	upper dead band temperature difference
ΔT_L	[C]	lower dead band temperature difference
T_H	[C]	upper Input temperature
T_{IN}	[C]	temperature for high limit monitoring
T_L	[C]	lower Input temperature
T_{MAX}	[C]	maximum Input temperature
γ_I	[0..1]	Input control function
γ_O	[0..1]	output control function

Mathematical Description

Mathematically, the control function is expressed as follows:

IF THE CONTROLLER WAS PREVIOUSLY ON

If $\gamma_I = 1$ and $\Delta T_L \leq (T_H - T_L)$, $\gamma_O = 1$

If $\gamma_I = 1$ and $\Delta T_L > (T_H - T_L)$, $\gamma_O = 0$

IF THE CONTROLLER WAS PREVIOUSLY OFF

If $\gamma_I = 0$ and $\Delta T_H \leq (T_H - T_L)$, $\gamma_O = 1$

If $\gamma_I = 0$ and $\Delta T_H > (T_H - T_L)$, $\gamma_O = 0$

There are two different controllers used in the computer model to simulate operator interaction. The first controller simulates an exhaust heat exchanger bypass. If the digesters reach 42 °C, the engine exhaust is diverted around the exhaust heat exchanger instead of through it. Once the digester temperatures drop below 40 °C the exhaust is diverted back through the exchanger. The second controller operates the heat dump modeled by the auxiliary chiller. If the

digester temperatures exceed 42 °C then the supplemental chiller is activated. Once the temperatures cool back down to 40 °C then the chiller is turned off.

C.2.9 Data Output

Proforma: Output\Online Plotter\Online Plotter With File\No Units\Type65c.tmf
TRNSYS Model: Type 65
The online graphics component is used to display selected system variables while the simulation is progressing. This component is highly recommended and widely used since it provides valuable variable information and allows users to immediately see if the system is not performing as desired. The selected variables will be displayed in a separate plot window on the screen. In this instance of the Type65 online plotter, data sent to the online plotter is automatically printed, once per time step to a user defined external file. Unit descriptors (kJ/hr, kg/s, degC, etc.) are NOT printed to the output file.
Proforma: Output\Printer\No Units\Type25c.tmf
TRNSYS Model: Type 25
The printer component is used to output (or print) selected system variables at specified (even) intervals of time. In this mode, unit descriptors (kJ/hr, degC, W, etc.) are NOT printed to the output file with each column heading. Output can be printed in even time intervals starting relative to the simulation start time or can be printed in absolute time. If relative printing is chosen with a one hour print interval and the simulation starts at time 0.5, values will be printed at times 0.5, 1.5, 2.5, etc. If absolute printing is selected, for the same simulation, values will be printed at times 0.5, 1.0, 2.0, 3.0, etc. Type25 is also able to print simulation information as a header to the output file (name of input file, and time of simulation run). It is further able to append new data to an existing file or can be set to overwrite the existing file.

The two types of data output utilized in the computer model are the online plotter and the output printer. The online plotter is used to confirm appropriate model response while the simulation is being run. The printer is used to print data to a text file so it may be imported to excel for analysis and manipulation.

C.3 Subsystems

Once all components have been properly defined, they must be linked together to simulate the interactions of the real world system. The three major subsystems will be described to show how these components are linked together. The included images are screenshots of the simplified computer model.

C.3.1 Digester Tanks

Figure 26 shows the macro that was developed to represent the four digesters and how they are fed. While there is only one feed stream from the manure pit and main ST heat exchanger, the four tanks must be fed equally and as near continuously as possible. The SDDS uses actuated valves to control the order and duration of feeding each tank. The forcing functions seen above are used to represent this. The current definitions, following SDDS operation, force the flow to go through each tank for fifteen minutes of every hour. The flow is then combined back into the main pipe to be sent through the WHR unit before disposal in the outdoor pits.

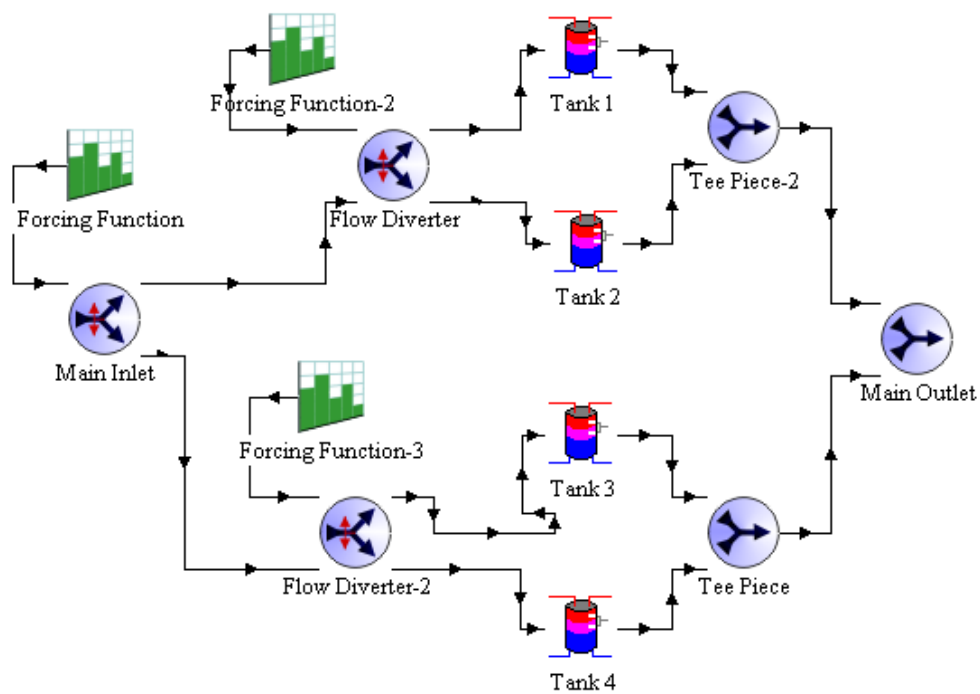

Fig. 26 - Digester System

C.3.2 Biogas Generation and Use

The biogas production is defined using the adapted Contois model discussed earlier. Figure 27 shows how this is modeled. The arrow at the top represents input information from the tanks of temperature and flow rate. The equation editors are used to calculate the specific gas production, the total gas production and the expected power output of the engine-generator. Also included here is the biogas chiller. Temperature and gas flow are defined from other components, while the set point temperature is defined by the user.

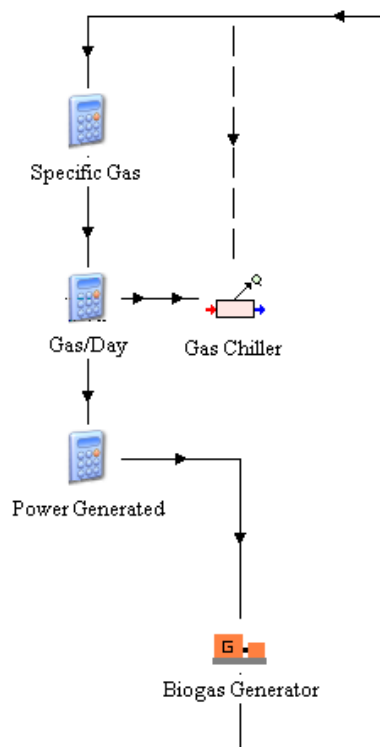

Fig. 27 - Gas Production System

C.3.3 Heat Loop

The third major component is the heat loop of the whole system. Figure 28 shows the configuration and interaction of the components. The heat loop circulates water to collect waste heat from the engine so it can be transferred to the manure slurry through the main ST heat exchanger. The waste heat of the engine-generator is used to define the temperature increase of the respective fluid streams. The controllers are used to limit the upper temperature of the heat loop (as defined by the tank temperatures). The heat exchangers are modeled according to the empirical analysis discussed in Appendix A.

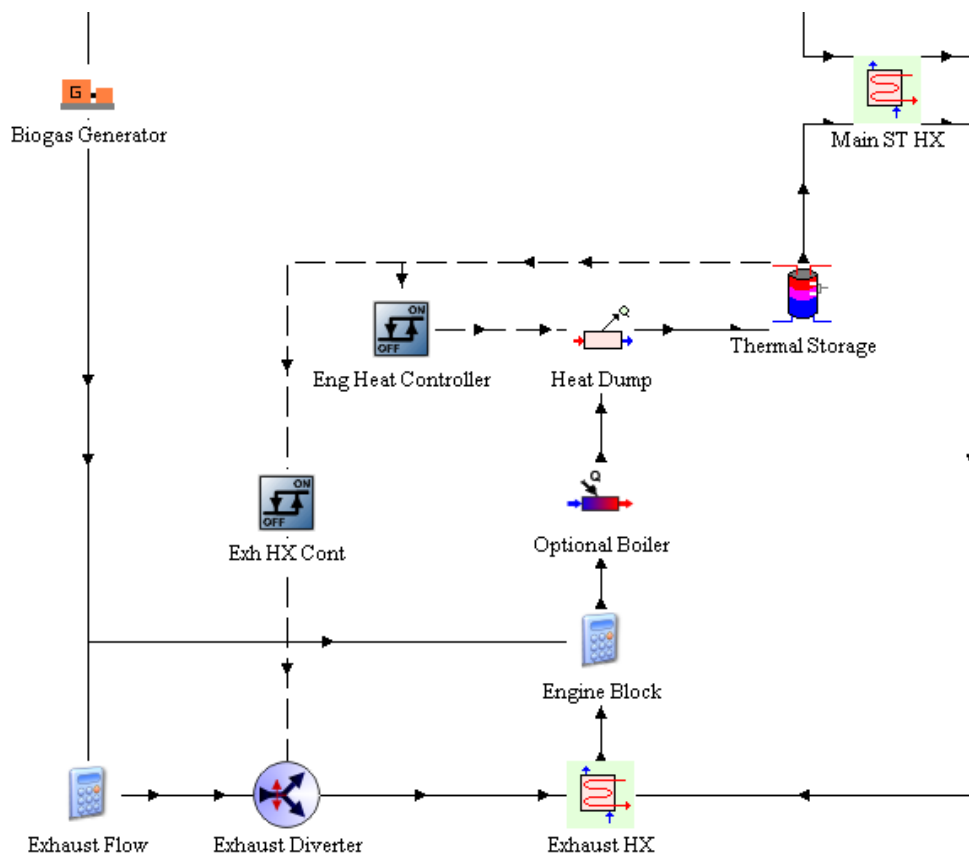

Fig. 28 - Heat Loop System

C.4 Full Model

These three subsystems, along with a few other components, are then combined to model the entire system. A screenshot of this combination is shown in Fig. 29. The component at the top-center of the above image represents the tank subsystem discussed in Section C.3.1. The digester slurry starts from the manure pits, goes through the waste heat exchanger, through the main ST exchanger, into the tanks and then finally back through the waste heat exchanger before it is dumped to the outdoor holding pit. The weather component determines not only the manure starting temperature, but also the temperature outside of the building. This temperature, combined with the sensible energy gain from the tanks (and the engine, which is not linked in the above image) determines the building temperature. This, in turn, affects the temperatures of the tanks.

The temperatures and flow rate of the digesters are used to define biogas production (shown on the left hand side of the image). The gas production rate is used to define the power output of the engine-generator, and also the waste heat of the engine. This heat is divided into its two components (exhaust heat and engine block heat) to be appropriately applied to heat loop. Once this heat is applied to the loop, the water stream goes through the supplemental heating and cooling units, where it is then sent through the main ST exchanger to heat the slurry. Being a closed loop, this water is circulated back through the exhaust exchanger and engine block to collect more heat.

