



PERFORMANCE OF GASOLINE/LPG BI-FUEL ENGINE OF MANIFOLD ABSOLUTE PRESSURE SENSOR (MAPS) VARIATIONS FEEDBACK

Muji Setiyo¹, Budi Waluyo¹, Willyanto Anggono² and Mohammad Husni³

¹Department of Automotive Engineering, Muhammadiyah University Magelang, Magelang, Indonesia

²Department of Mechanical Engineering, Petra Christian University, Surabaya, Indonesia

³Department of Autotronic, Vocational Education Development Center, Malang, Indonesia

E-Mail: willy@petra.ac.id

ABSTRACT

Liquefied Petroleum Gas (LPG) is an alternative fuel in spark ignited premix combustion engine and emissions from LPG engines are lower than those in gasoline engines. This article presents a novel method of changing the ignition curve in an LPG/Gasoline bi-fuel engines which still use the converter and mixer models. The goal of this research was to get the best engine power in fuel operating mode both gasoline and LPG. It is known that the gasoline and LPG have different properties, especially burning speeds. In order to obtain optimum engine performance in both fuels, there should be two ignition curves, one for gasoline and the other for LPG. A circuit Simple Electronic Spark Module (SESM) was applied to manipulate the feedback voltage from a Manifold Absolute Pressure Sensor (MAPS). In the gasoline mode when idle, feedback from the MAPS was 1.4 volts. In this study, the standard ignition curve was maintained for the gasoline operation mode, whereas, in the LPG operation mode, feedback from MAPS was varied at 1.4; 1.2; 1.0; 0.8; and 0.6 volts at idling respectively. The Toyota 5A-FE engine was tested on a chassis dynamometer to confirm the performance of the circuit. Test results show that the feedback of 0.8 volts produced the best power when the engine running on LPG.

Keywords: Bi-Fuel engine, MAPS feedback, SESM, engine performance.

1. INTRODUCTION

Liquefied Petroleum Gas (LPG) is an alternative fuel that is derived from the refining of crude oil or natural gas. LPG consists of propane or butane or a mixture of both. Ethane or pentane is also present in the mixture in small amounts. LPG is the fuel that has all the key properties required for the Spark-Ignition Engine [1].

The main reasons why governments in many countries actively encourage the use of LPG and other alternative fuels are environmental [2]. Emissions of the LPG-fueled engine compared to those from gasoline ones have been studied by many researchers and some of them concluded that emissions from LPG engines were lower than those from gasoline ones [3,4]. Yet, LPG has negative effects on engine performance, fuel economy and engine structural elements when it is used at the same fuel-air equivalence ratios as gasoline [5]. Furthermore, LPG storage displaces 15–20% greater volume than gasoline and its power output decreases by 5–10% [6]. However, for reasons of lower emissions and pricing, LPG is more promising than gasoline.

Now, there are nearly 25 million LPG vehicles used throughout the world, in both private and public transportation such as taxis and buses. However, the use of LPG is still concentrated in a small number of countries including South Korea, Turkey, Russia, Poland and Italy. In the ASEAN region, Thailand has a successful country with a policy where LPG is encouraged as a vehicle fuel, both in the number of vehicles and consumption as shown in Table-1. Thailand outpaces Malaysia, Singapore and other ASEAN countries.

Table-1. The largest LPG markets in 2013 [2].

Country	Consumption (Thousand tons)	Vehicles (Thousands)	Refueling stations
South Korea	3987	2410	1994
Russia	2850	3000	4400
Turkey	2727	3935	10089
Thailand	1775	1020	1090
Poland	1575	2750	5520
Italy	1520	1930	3250
Japan	980	234	1517
Ukraine	821	1500	2750
Australia	813	490	3703
China	730	141	310
Rest of the World	8024	7501	35749
World	25802	24911	70372

To operate vehicles with LPG, either as full-dedicated or bi-fuel (gasoline and LPG alternately operated), only slight modifications are needed in the fuel system [7]. Fuel converter kits have been developed for car fuel systems. The four main types of LPG fuel systems commonly used are converter and mixer, vapor phase injection, liquid phase injection, and liquid phase direct injection [2].

Converter and mixer was the first-generation device for gasoline to LPG conversion and was similar to carburetor system. The LPG flows from the converter to



the intake manifold based on vacuum in the mixer, then LPG is inserted into the engine. It has existed since the 1940s and it is still widely used today, especially in vehicles that have not been modified for bi-fuel. Vapor Phase Injection (VPI) system uses a converter such as the first generation with a few improvements. The gas flows from the converter at a higher pressure than that of the old system. The gas is then injected into the intake manifold. Liquid Phase Injection (LPI) system does not use a converter but it provides liquid fuel directly into the fuel rail, like gasoline injection system. This system supplies LPG to the engine in accurate volumes. Liquid Phase Direct Injection (LPDI) system is the most advanced among the others, LPDI uses a high-pressure pump and injector to inject the liquid LPG directly into the combustion chamber. Moreover, losses due to evaporation of LPG in the intake manifold can be eliminated in this system [2].

Among the four of LPG conversion systems, the converter and mixer system is the simplest and can be installed almost in all existing vehicle technologies. Meanwhile, LPI and LPDI models use complex electronic controls and are complicated and not compatible for application in older model vehicles. Along with the market demand, automotive manufacturers have added the LPG fuel system to products marketed in some countries. However, for a country that is developing its infrastructure for gas fuel systems such as Indonesia, the converter and mixer system is the most acceptable. This is because almost all existing vehicles are not equipped with the LPG fuel system. The bi-fuel system is also an option so that a car can be operated with two fuels interchangeably. However, the number of LPG filling stations is still limited [2].

Research Octane Number (RON) and burning speed are important characteristics in the combustion processes. LPG has a higher Research Octane Number (112 RON) and a lower burning speed than gasoline. The ignition timing for LPG mode must be advanced in order to obtain the Maximum Brake Torque [8, 9, 10-14]. If the initial reference for gasoline operation is 10°BTDC, the LPG operation becomes 25°BTDC, as shown in Figure-1.

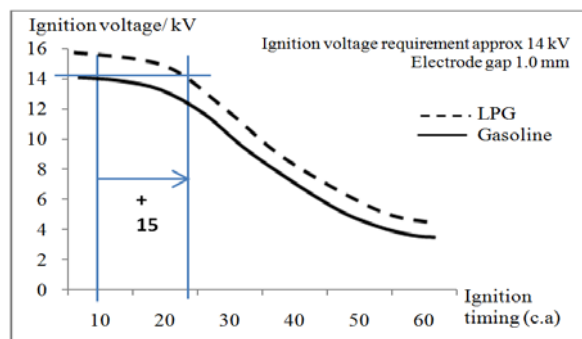

Figure-1. Ignition timing for LPG engine [8].

A testing was conducted with HD-5 liquid propane in a Stock Ford Taurus 3.5 L V6 Eco Boost. This

study reported that the ignition timing could be advanced by 20 degrees in the full load, and the knock limit was not reached at any point. Significantly, a better thermal efficiency was demonstrated with optimized ignition [15]. timing. Previously, Lawankar (2012) also has examined in detail the performance of LPG-fueled SI engines at different compression ratios and ignition timing. The results showed that the ignition timing influenced brake thermal efficiency. It was observed that the efficiency at part and peak was higher at 20°BTDC for the gasoline-fueled engines and at 30°BTDC for LPG fueled engine for all of compression ratios [16].

Referring to the previous studies [8, 15, 16], which found that the bi-fuel engines require two ignition curves. If only one ignition curves for gasoline mode available, it will cause a significant power drop when operated in LPG mode. Conversely, if the ignition curve refers to the LPG mode, knocking will occur when using gasoline. To achieve maximum results in both modes of fuel, ignition curves must be changed follow the fuel used. Ignition curves should be able to move forward or backward automatically when the fuel operation is changed, especially during engine acceleration and heavy loads.

The best way to ensure that the ignition is optimized for both fuels is by installing an ignition device, known also as "Dual Curves". It is wired to the ignition system and switches automatically to the LPG or gasoline setting when the fuel switch is activated. They will give more initial advance than that for the gasoline setting when the engine is running on LPG, and as speed increases they will give better performance [17].

Efforts to adjust the ignition curve in LPG, CNG and gasoline engine have been performed [18]. A Timing Advance Processor was applied to manipulate the signals from the ignition coil. The signal is processed further through this device before it is fed back to the Engine Control Unit (ECU). The processor spark advance was also investigated [19] and tested on CNG-fueled engines. This variation in spark requirement is mainly due to the slower speed of flame propagation for natural gas. Another device for controlling ignition curve is called Electronic Spark Advance Variator [20]. Both Timing Advance Processor and Electronic Spark Advance Variator work based on a signal from the ignition coil and their disadvantages are during acceleration and heavy loads have not yet been solved.

This article presents a novel method for controlling the ignition timing of bi-fuel engine. The goal is to improve the power loss when running on LPG during acceleration and heavy loads and to maintain power when running on gasoline. The ignition curve can be changed based on information from the Manifold Absolute Pressure Sensor (MAPS). This method is especially used in conventional bi-fuel engines (using the converter and mixer models). This method was named Simple Electronic Spark Module (SESM). The basic principle behind this method is the MAPS sends a feedback signal varying from 4.5-0.5 volts based on intake manifold pressure (101-20.1 kPa). At idling speed for gasoline engines, the feedback



from MAPS ranges from 1.4 to 1.5 volts which are linear with manifold pressure. When the engine is running on LPG, the feedback is lower than 1.4 volts as the engine works at higher intake manifold pressures.

The Total Ignition Timing (TIT) of EFI engines is based on the ECU setting then corrected by engine conditions recorded by sensors. The formula is given as follows: $TIT = BIT + AT + CT + BP + MC + CC + UI$ [9]. Where the 7,7 is based on ignition timing from the main ignition table, $\$7$ is air temperature compensation, $\&7$ is coolant temperature compensation, $\%3$ is barometric pressure compensation, $0 \&$ is MAP compensation, $\&\&$ is individual cylinder compensation, and 8 is user selectable input compensation. In advanced ignition curve when running on LPG mode, especially during engine acceleration, the feedback from MAPS is manipulated by simple electronic circuits. The feedback from the MAPS is lowered a few volt before being supplied to ECU. The voltage difference can be set as desired by adjusting the variable resistor. By applying this method, the ECU receives information as though the engine was running at higher intake manifold pressures so that ignition shifts forward. When the engine is returned to gasoline operation, the feedback voltage from the MAPS does not pass through the circuit and returns to the normal ignition curve [9].

2. EXPERIMENT METHODS

The engine used throughout this study was a Toyota 5A-FE that has been modified for a bi-fuel system. The converter used was a Stefanelli 150HP. The engine specification, and LPG/Gasoline bi-fuel engine installation are presented in Table 2 and Figure-2 respectively.

Table-2. Engine specification.

Engine manufacturer	Toyota
Engine model	5A-FE
Cylinders	Inline 4
Capacity	1498 cc
Bore × Stroke	78.7 × 77 mm
Valve mechanism	DOHC, 4 valves per cylinder, 16 valves in total
Maximum power output	77 kw @ 6000 rpm
Maximum torque	135 Nm @ 4800 rpm
Compression ratio	9.8:1
Fuel system	EFI

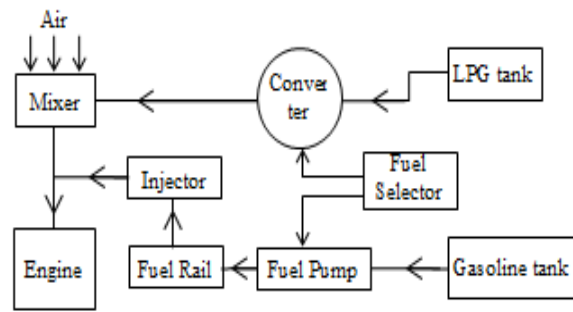

Figure-2. LPG/Gasoline bi-fuel engine installation.

When the fuel selector is shifted to the LPG mode, RL2 is activated so that the feedback voltage from the MAPS will be processed through the circuit. When the operating mode is shifted to Gasoline, RL2 becomes non-active, the feedback voltage from the MAPS will be supplied directly to the ECU. The simple electronic spark module (SESM) shown in Figure-3.

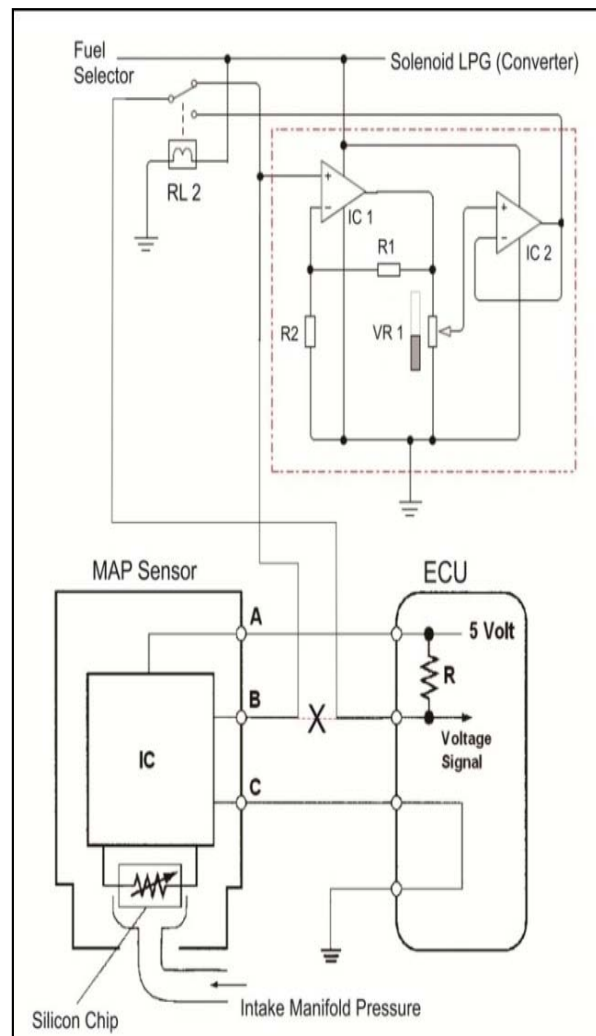

Figure-3. Simple Electronic Spark Module (SESM).



Under the standard conditions and the engine is running on gasoline, the current from ECU to MAPS (A) is 5 volts and feedback from MAPS to ECU (B) is about 1.4 volts at idling (± 37 kPa) and increases linearly up to 4.5 volts at 100 kPa. When the engine is running on LPG, the outputs from SESM are set at 0.6; 0.8; 1.0; 1.2; and 1.4 volts at idling. Compared to the data standard, MAPS graph after passing through the circuit is presented in Figure-4.

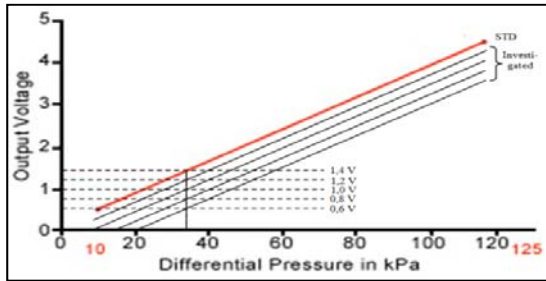

Figure-4. MAPS graphs before and after through the SESM.

In this study, a Hofmann Dynatest Pro - 260 kW chassis dynamometer was used in a "Program P-Max" menu. This test was used to obtain the engine curve (power and torque). Coast-down test procedure was performed to obtain the actual vehicle characteristics. The vehicle was accelerated from standstill to maximum speed by changing gears smoothly but quickly. Once maximum power had been exceeded, the clutch was disengaged and the engine was allowed to coast-down. During coasting, power loss was constantly determined and the measured parameters of power, velocity, and torque were obtained. The experimental set up for this research is shown in Figure-5.



Figure-5. Experimental set up.

3. RESULTS AND DISCUSSIONS

In this study, the engine power was set from 1500 to 6000 rpm. A series of tests showed that the MAPS feedback control (which meant changing the ignition timing) had a major effect on output torque and engine power (Figure-6). In the LPG operation mode and without control of MAPS feedback (V: 1.4), the engine power was very low (Curve 5). It can be clearly seen that the

maximum power only generated 61.5 hp @ 5045 rpm while the gasoline mode was capable of producing 75.4 hp @ 5049 rpm (Curve 6), a decrease of 14.5%. Moreover, at engine speeds below 2000 rpm, there were significant power drops.

When the MAPS feedback was lowered to 1.2 volts in the LPG mode (curve 4) after passing through the SESM, maximum engine power increased to 68.6 hp @ 5414 rpm, a difference of only 9% from the gasoline operation mode. The engine gave good performance at high rpm, but still performed poorly at low rpm. The good results were obtained at the MAPS feedbacks of V:1.0 and V:0.8 (curves 3 and 2) with a graphic power that was nearly coincident, but the V:0.80 was better than V:1.0. Although the maximum power was not been able to match that of the gasoline engine, the results are in accordance with the theory given by Bosch (2010) [8].

When the MAPS feedback was lowered again to 0.6 Volts (Curve 1), the maximum power declined. This confirms the results achieved by Lawankar [16]. Additionally the power loss by applying of SESM was only 4%. While in the Ceviz paper [6], the power losses due to the LPG application were approximately 5-10%.

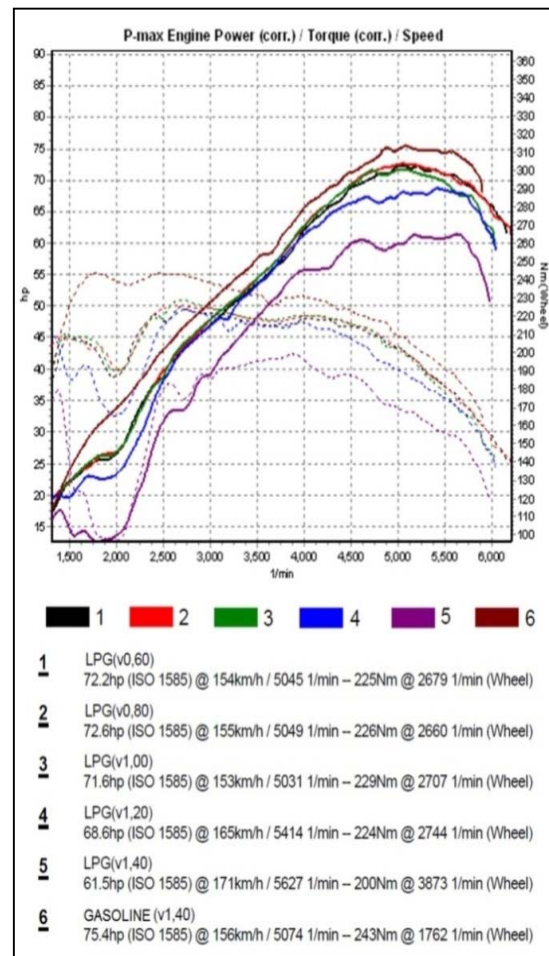

Figure-6. The effect of MAPS feedback to engine power at various MAPS feedback.

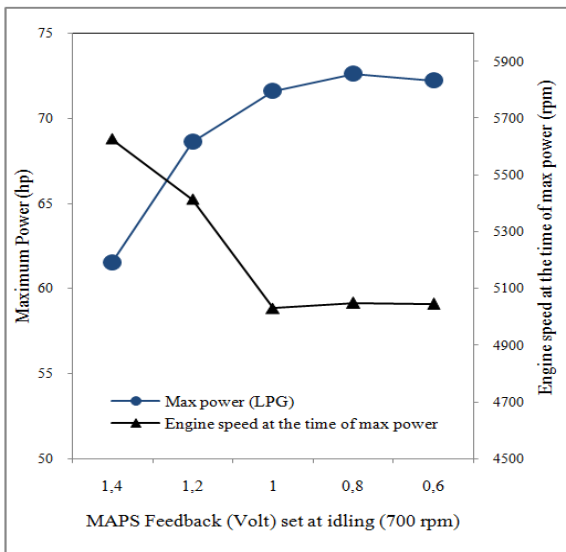

Figure-7. The effect of MAPS feedback on maximum power in the LPG mode.

The effect of MAPS feedback on maximum power when running on LPG is presented in Figure-7. Engine speed at maximum power is also presented to confirm the working conditions of the engine. Maximum power rose significantly when the MAPS feedback lowered to 1.2 Volts and then 1.0 Volt. The maximum power was also obtained at lower rpm than MAPS feedback set at 1.4 volts. Furthermore, the best maximum power occurred when the MAPS feedback was set at 0.8 volt.

4. CONCLUSIONS

A Simple Electronic Spark Module (SESM) to control the ignition timing for bi-fuel engine could produce better engine performance in the two modes of fuel, LPG and gasoline, especially during acceleration and heavy loads. When the engine is running on LPG and the MAPS feedback changes from 1.4 to 1.0 volts and has a significant effect, although in the range of 1.0 to 0.6 volts showed almost the same results, the best maximum power occurred when the MAPS feedback was set at 0.8 volt. In conclusion, the power loss in bi-fuel engines when running on LPG can be corrected by manipulating the MAPS feedback before it is supplied to the ECU.

ACKNOWLEDGEMENTS

The authors wish to thank the Ministry of Research, Technology and Higher Education, Republic of Indonesia through the INSINAS programs and the Research Division, Muhammadiyah University Magelang for their supports.

REFERENCES

[1] Saraf R.R, Thipse S.S and Saxena P.K. 2009. Comparative Emission Analysis of Gasoline / LPG

Automotive Bifuel Engine. *International Journal of Civil and Environmental Engineering*. 1(4): 199-202.

- [2] WLPGA. 2014. Autogas Incentive Policies : A country-by-country analysis of why and how governments encourage Autogas and what work.<http://www.wlpga.org/>.
- [3] Mockus S., Sapragonas J., Stonys A., Pukalskas P. 2006. Analysis of Exhaust Gas Composition of Internal Combustion Engines Using Liquefied Petroleum Gas. *Journal of Environmental Engineering and Landscape Management*. 17(1): 16-22.
- [4] Shankar K. S. And Mohanan P. 2011. MPFI Gasoline Engine Combustion, Performance And Emission Characteristics With LPG Injection. *International Journal Of Energy And Environment*. 2(4): 761-770.
- [5] Bayraktar H. and Durgun O. 2005. Investigating the effects of LPG on spark ignition engine combustion and performance. *Energy Conversion and Management*. 46(13-14): 2317-2333.
- [6] Ceviz M. A. and Yüksel F. 2006. Cyclic variations on LPG and gasoline-fuelled lean burn SI engine. *Renewable Energy*. 31(12): 1950-1960.
- [7] Werpy M.R., Burnham A., Bertram K. 2010. Propane Vehicles: Status, Challenges, and Opportunities. Illinois, USA: Center for Transportation Research, Argonne National Laboratory.
- [8] Bosch R. 2010. LPG Spark Plugs, Road Clayton: Robert Bosch (Australia) Pty Ltd.
- [9] Krummen J. 2011. ECUs and Engine Calibration 201. Performance Electronics, Ltd. www.pe-ltd.com.
- [10] Anggono W., Wardana I.N.G., Lawes M., Hughes K.J., Wahyudi S., Hamidi N. and Hayakawa A. 2013. Biogas laminar burning Velocity and flammability characteristics in spark ignited premix combustion. *Journal of Physics: Conference Series*. 423: 1-7.
- [11] Anggono W., Wardana I.N.G., Lawes M. and Hughes K.J. 2014. Effect of inhibitors on biogas laminar burning velocity and flammability limits in spark ignited premix combustion. *International Journal of Engineering and Technology*. 5: 4980-4987.
- [12] Anggono W., Wardana I., Lawes M., Hughes K. J., Wahyudi S. and Hamidi N. 2012. Laminar burning characteristics of biogas-air mixtures in spark ignited



premix combustion. *Journal of Applied Sciences Research*. 8: 4126-4132.

- [13] Anggono W., Wardana I., Lawes M., Hughes K. J., Wahyudi S. and Hamidi N. 2013. Laminar burning velocity and flammability characteristics of biogas in spark ignited premix combustion at reduced pressure. *Applied Mechanics and Materials*. 376: 79-85.
- [14] Bradley D., Hicks R.A., Lawes M., Sheppard C.G.W. and Wooley R. 1998. The measurement of laminar burning velocities and Markstein numbers for isooctane-air and iso-octane-n-heptane-air mixtures at elevated temperatures and pressures in an explosion bomb. *Combustion and Flame*. 115: 126-144.
- [15] Southwest Research Institute. 2014. How Propane Autogas Can Enable High Efficiency Engine. http://www1.eere.energy.gov/cleancities/pdfs/patf14_ross.pdf.
- [16] Lawankar S.M and Dhamande L.P. 2012. Comparative Study of Performance of LPG Fuelled Si Engine at Different Compression Ratio and Ignition Timing, *International Journal of Mechanical Engineering and Technology*. 3(4), pp. 337-343.
- [17] Dimovski K. General Information - Ignition timing for engines converted to run on LPG. <http://www.acl.com.au/web/acl00056.nsf/0/359683e8a538a3e64a2566c0007bb33e?OpenDocument>.
- [18] Tomov O. 2012. Timing Advance Processor for Internal Combustion Engine Running on LPG/CNG. *Proceedings Electrical Engineering, Electronic, Automation*. ISSN 1311-3321. University of Ruse, Angel Kanchev. 51(3.2): 184-187.
- [19] Ehsan Md. 2006. Effect Of Spark Advance On A Gas Run Automotive Spark Ignition Engine. *Journal of Chemical Engineering*. 24 (1): 42-49.
- [20] AEB. Technical Manual for Spark Advance Variators. Cavriago: A.E.B.s.r.l. <http://www.emmegas.net/>.