



2013

FY13 Scope III Emissions Methodology and Data

Mohamad Farzinmoghadam

University of Massachusetts - Amherst, mfarzinmoghadam@larp.umass.edu

Ludmilla Pavlova-Gillham

University of Massachusetts - Amherst, lpavlova@cp.umass.edu

Follow this and additional works at: https://scholarworks.umass.edu/sustainableumass_data



Part of the [Oil, Gas, and Energy Commons](#), and the [Sustainability Commons](#)



This work is licensed under a [Creative Commons Attribution 4.0 License](#).

Farzinmoghadam, Mohamad and Pavlova-Gillham, Ludmilla, "FY13 Scope III Emissions Methodology and Data" (2013). *Campus Data*. 29.

Retrieved from https://scholarworks.umass.edu/sustainableumass_data/29

This Article is brought to you for free and open access by the Sustainable UMass at ScholarWorks@UMass Amherst. It has been accepted for inclusion in Campus Data by an authorized administrator of ScholarWorks@UMass Amherst. For more information, please contact scholarworks@library.umass.edu.

UMass Greenhouse Gas Emissions

Ludmilla Pavlova-Gillham Mohamad Farzinmoghadm

PROJECT OBJECTIVES

Develop a method for Scope 3 emissions calculation related to employer passenger vehicle commuting

Calculate UMass FY 2013 Scope 3 emissions

Document the process for future application

UMASS Parking Services

Database of parking permits and their holders

UMASS Human Resources

Database of individuals and their personnel type

MASS GIS resources

Online geocoding Service

Neighboring States resources

Online North America Routing Service

PARKING SERVICES – DATA

10,270 records in Excel, Provided with detailed information

id	Status	address	city	State	zip	LOT	MAKE	MODEL	YEAR
1000	Employee	10 Palley Village Place	Amherst	MA	01002	Lot 67	TOYO		2000
1001	Employee	61 Woodbridge Terrace#6	South Hadley	MA	01075	Lot 65	MINI		2006
1002	Employee	221 Massachusetts Ave	Boston	MA	02115	Lot 24	LEXU	ES250	2010
1003	Employee	104 State Street	Northampton	MA	01060	Lot 32	HOND	CRV	2001
1004	Employee	60 Patterson Avenue	Springfield	MA	01119	Lot 65	AUDI		2013
1005	Employee	112 SUNSET DRIVE	SPRINGFIELD	MA	01109	Lot 33	NISS	VERSA	2007
1410	Employee	280 Green River Road	Greenfield	MA	01301	Upper Garage	FORD	FOC	2008
1416	Employee	West Leyden Rd	Leyden	MA	01337	Motorcycle	BMW		2007
1417	Employee	West Leyden Rd	Leyden	MA	01337	Lot 27	HOND		2001
1418	Employee	22 Salem Place	Amherst	MA	01002	Lower Garage	NISS	ALT	2002
1419	Employee	66 Gulf Road	Belchertown	MA	01007	Transit	TOYO		2007
1432	Employee	156 School St	Greenfield	MA	01301	Night	TOYO	COR	2010
1530	Employee	86 S Plain Rd	Sunderland	MA	01375	Special	PONT	VIB	2009
1556	Employee	10A Hadley Rd.	Sunderland	MA	01375	Child Care	HYUN	ELA	2007
1576	Employee	404 Alvord Place	South Hadley	MA	01075	Upper Garage	SUBA	FOR	2008
11269	Student		WORCESTER		01604	Lot 66	HYUN	ELA	2013

COMMUTER TOWNS

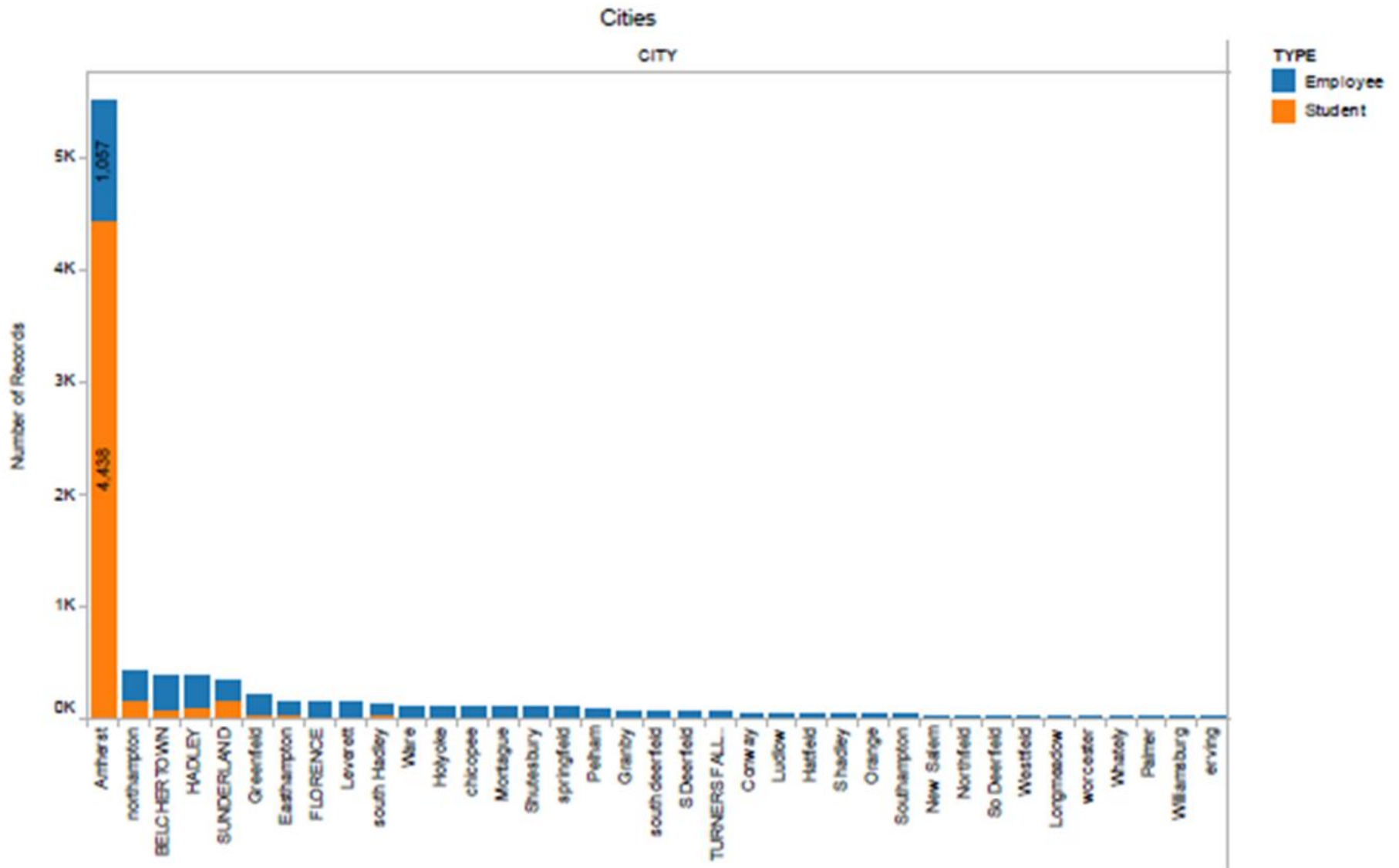

Sum of Number of Records for each CITY. Color shows details about TYPE.

COMMUTER TOWNS – NUMBER OF RECORDS

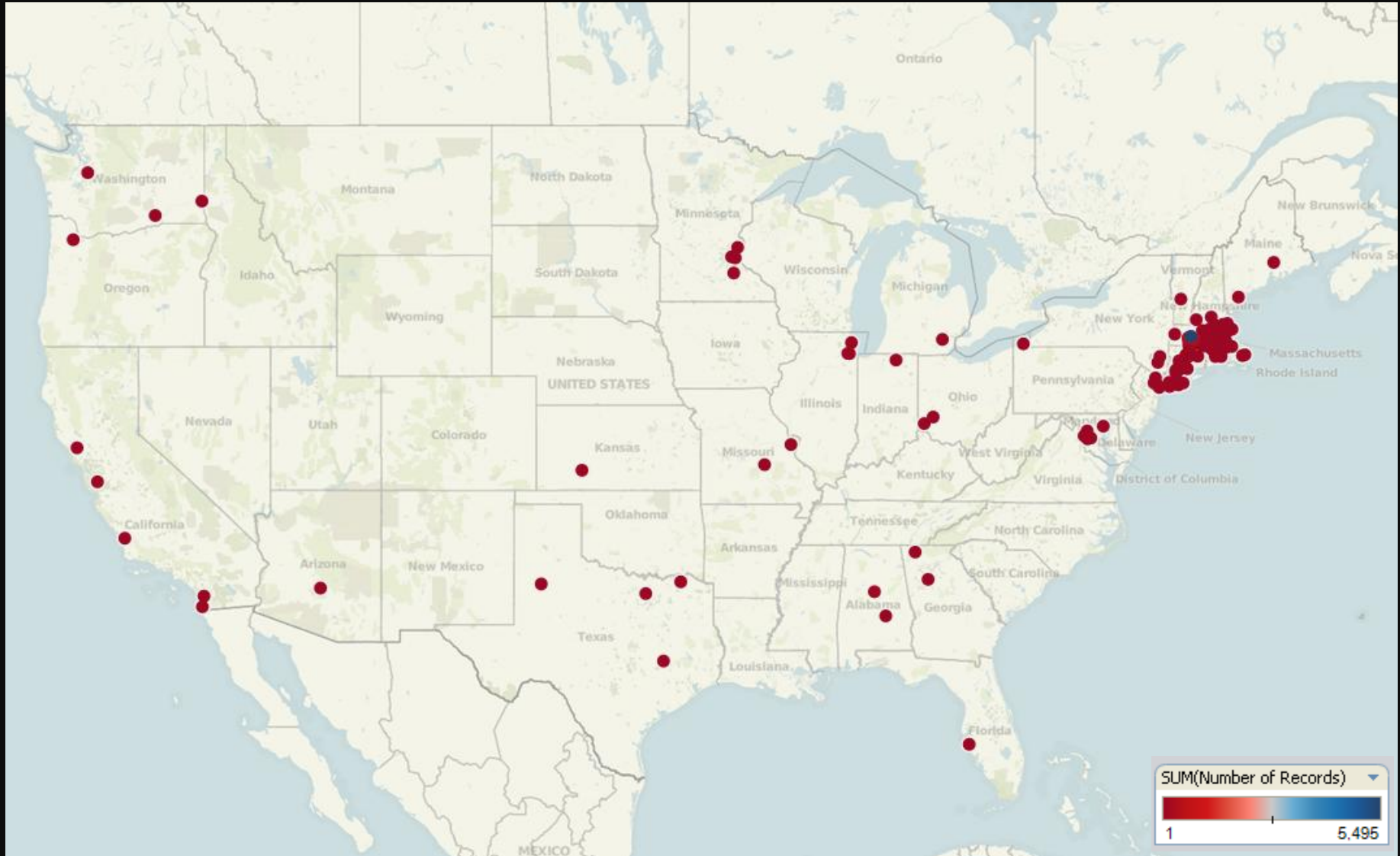

PROJECT METHOD

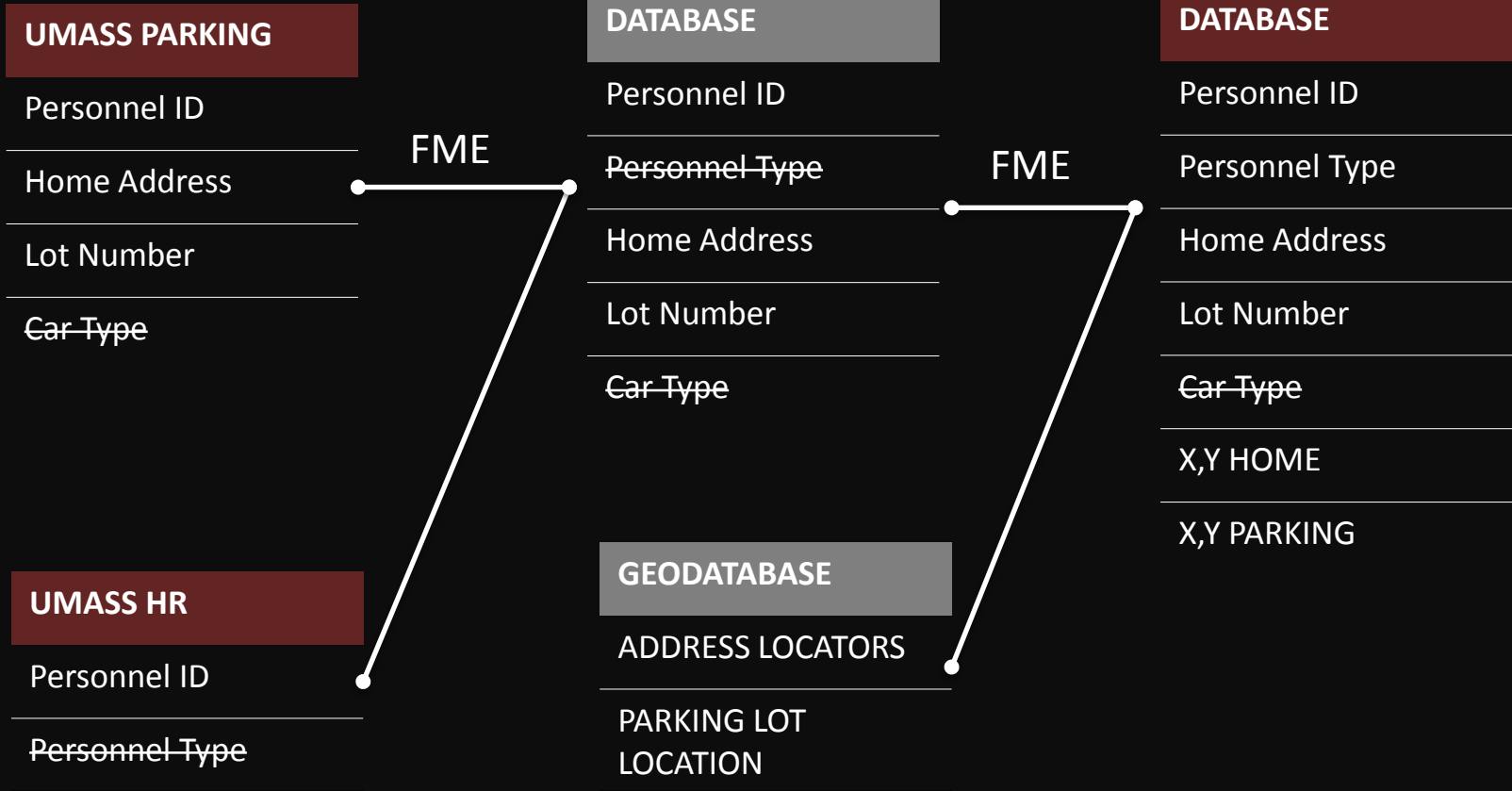

PROJECT METHOD

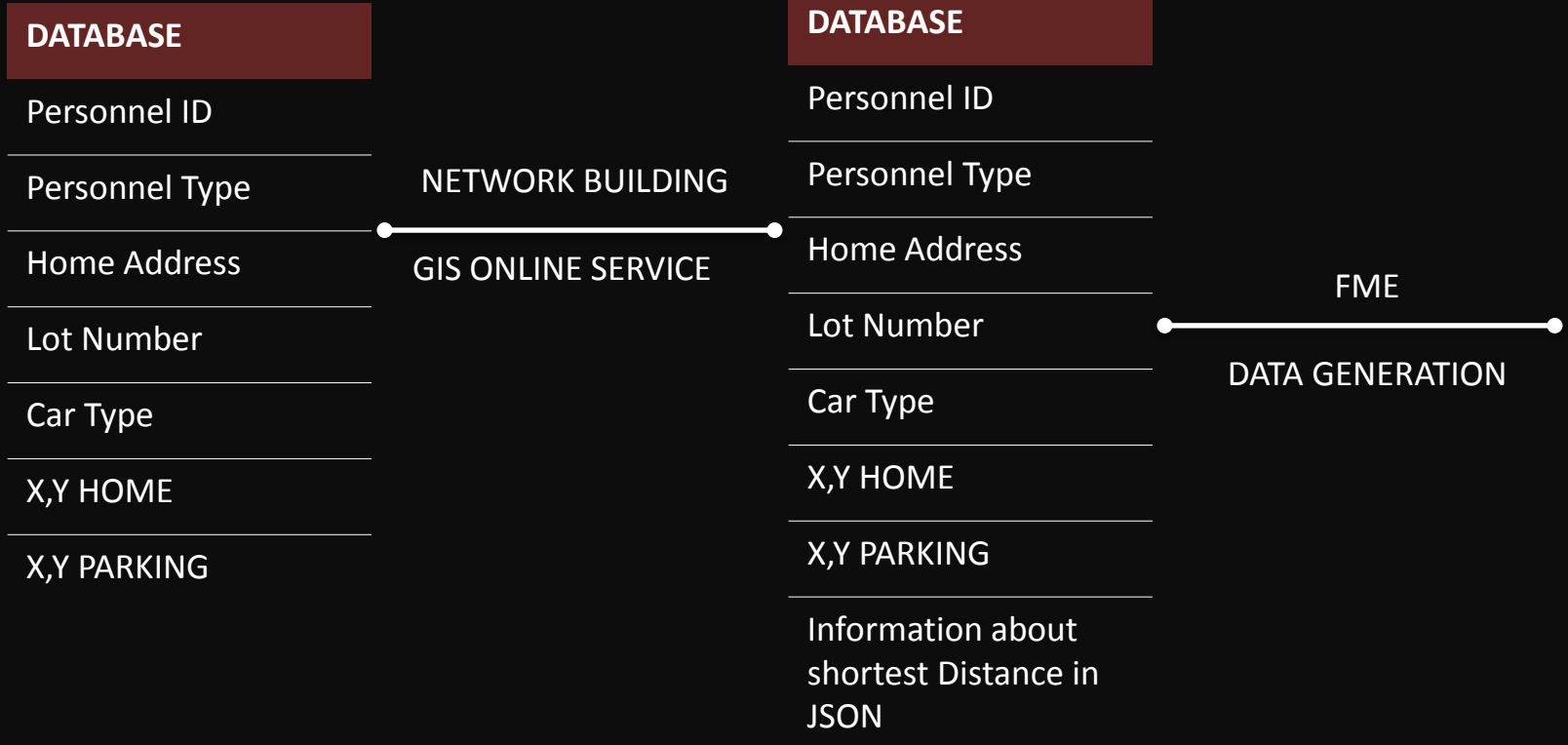

FME FRAMEWORK (Parking and Address merging features)

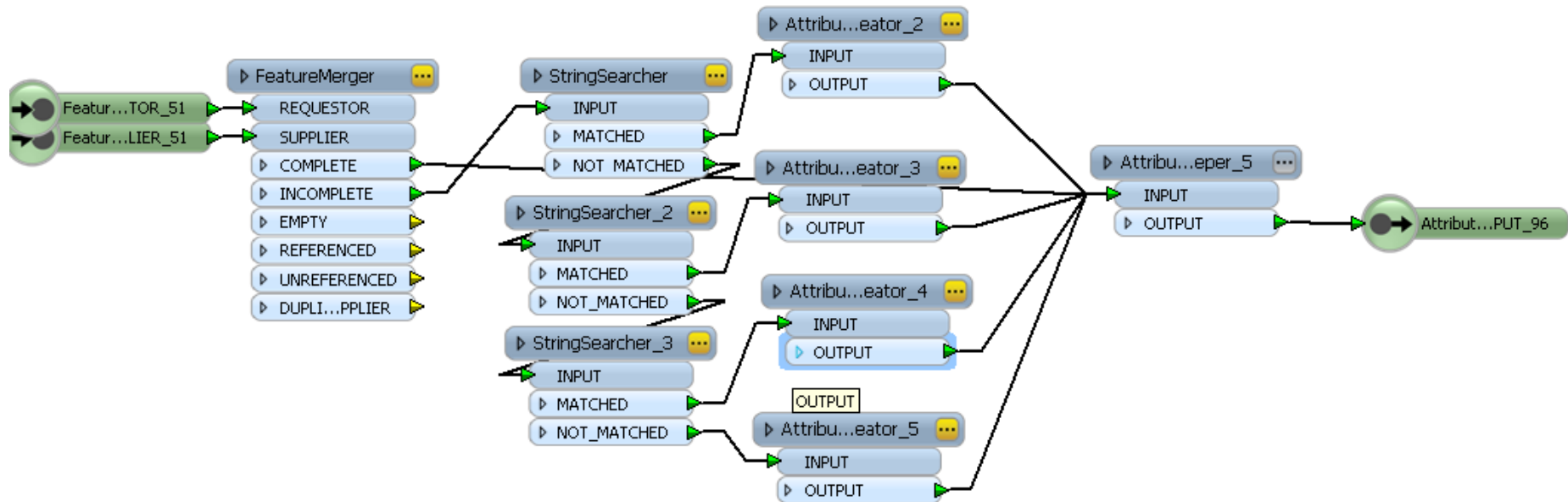

Max work days/employee = $(52 * 5) - 15 = 245$ days

Employees park on campus an average of 80% of the time

$245 * 0.8 = 196$ days

Total AVMT per person = Commute/miles * 196 days

Max student study days = $(32 * 5) - 5 = 155$ days

Students park on campus an average of 80% of the time

$155 * 0.8 = 124$ days

Total AVMT per person = Commute/miles * 124 days

COMMUTER TOWNS

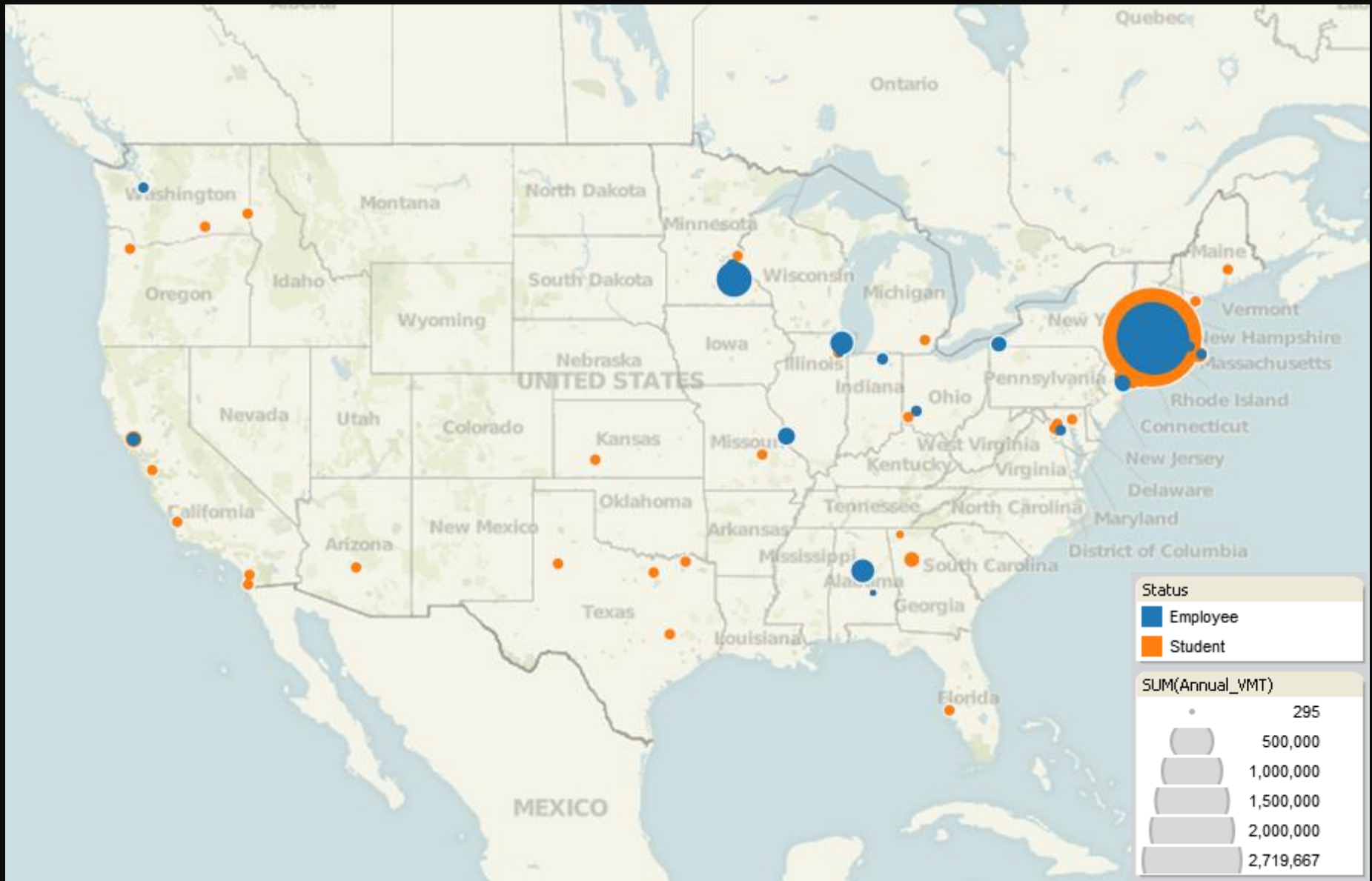

UMASS EMPLOYEE VEHICLE MILLAGE TRAVEL

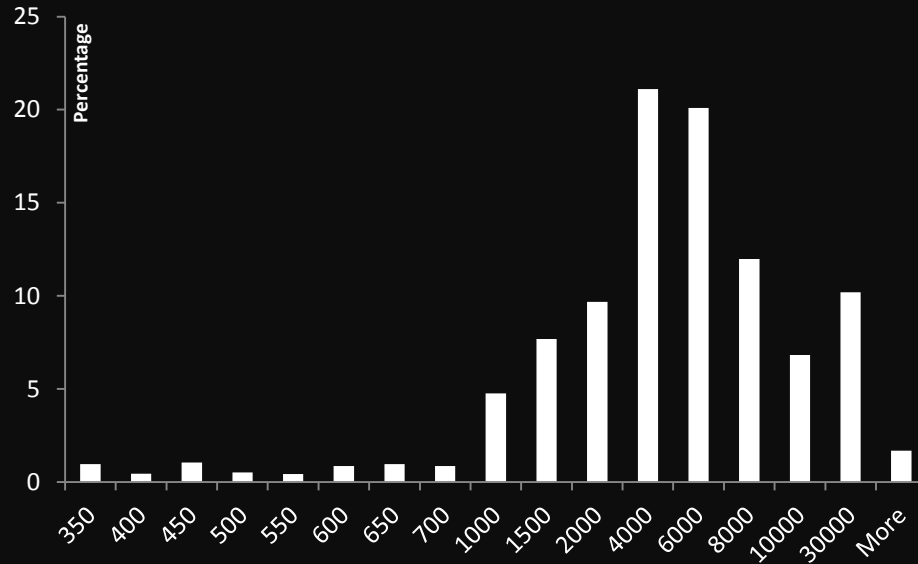
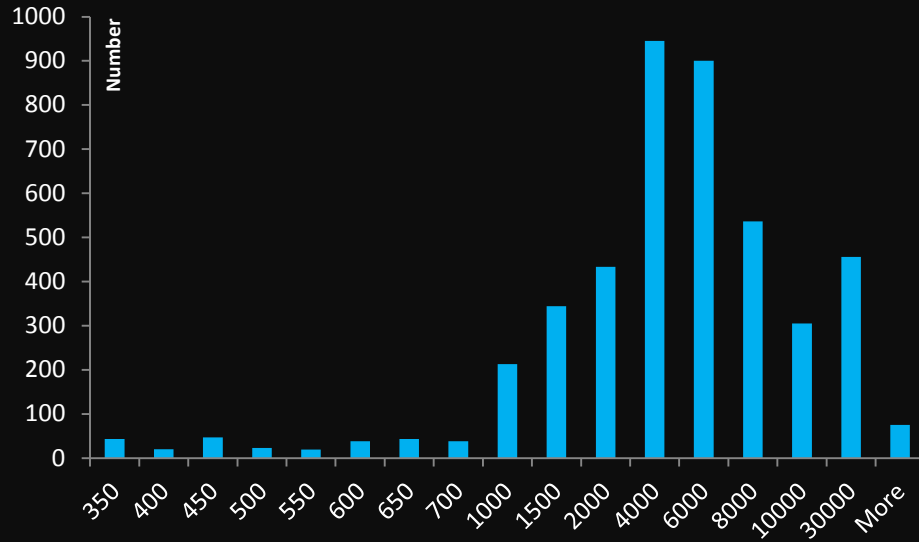

UMASS EMPLOYEE VEHICLE MILLAGE TRAVEL

<i>Annual_VMT</i>	<i>Frequency</i>	<i>Percentage</i>
350	43	0.96
400	20	0.45
450	47	1.05
500	23	0.51
550	19	0.42
600	38	0.85
650	43	0.96
700	38	0.85
1000	213	4.76
1500	344	7.68
2000	433	9.67
4000	945	21.10
6000	900	20.10
8000	536	11.97
10000	305	6.81
30000	456	10.18
More	75	1.67
Total	4478	100

Median Annual VMT :

4,066 Miles

Average Annual VMT:

5,400 Miles

Max Annual VMT:

36770 Miles

Min Annual VMT:

22 Miles

Total Annual VMT:

24,179,160 Miles

UMASS EMPLOYEE COMMUTING IN PERSPECTIVE

24,179,160 Miles = **971** times around the Earth

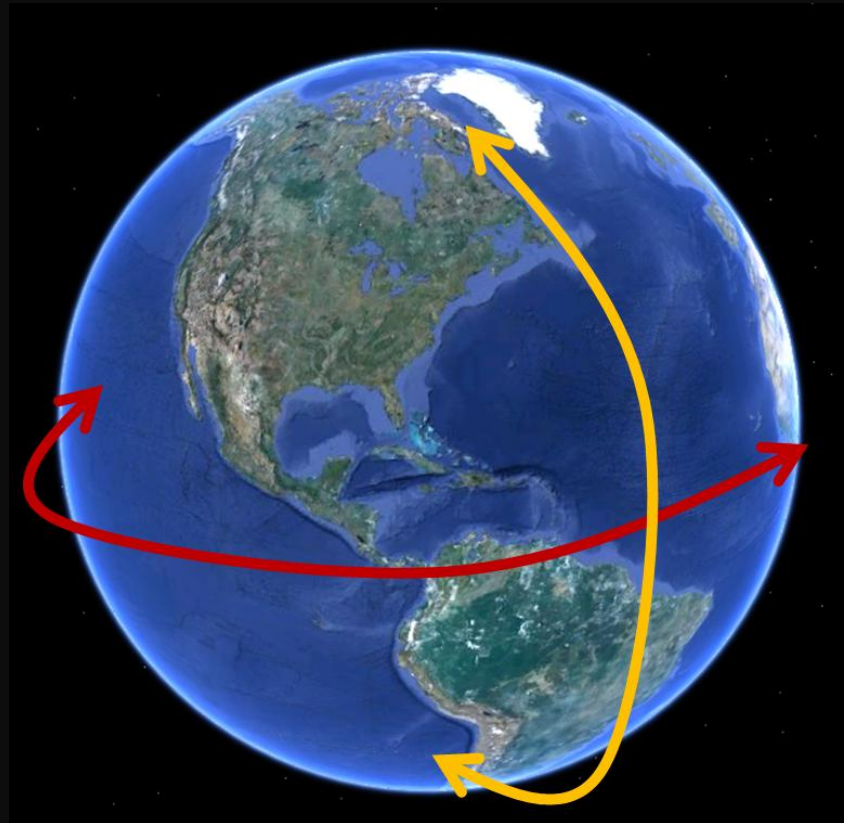

UMASS EMPLOYEE VEHICLE MILLAGE TRAVEL

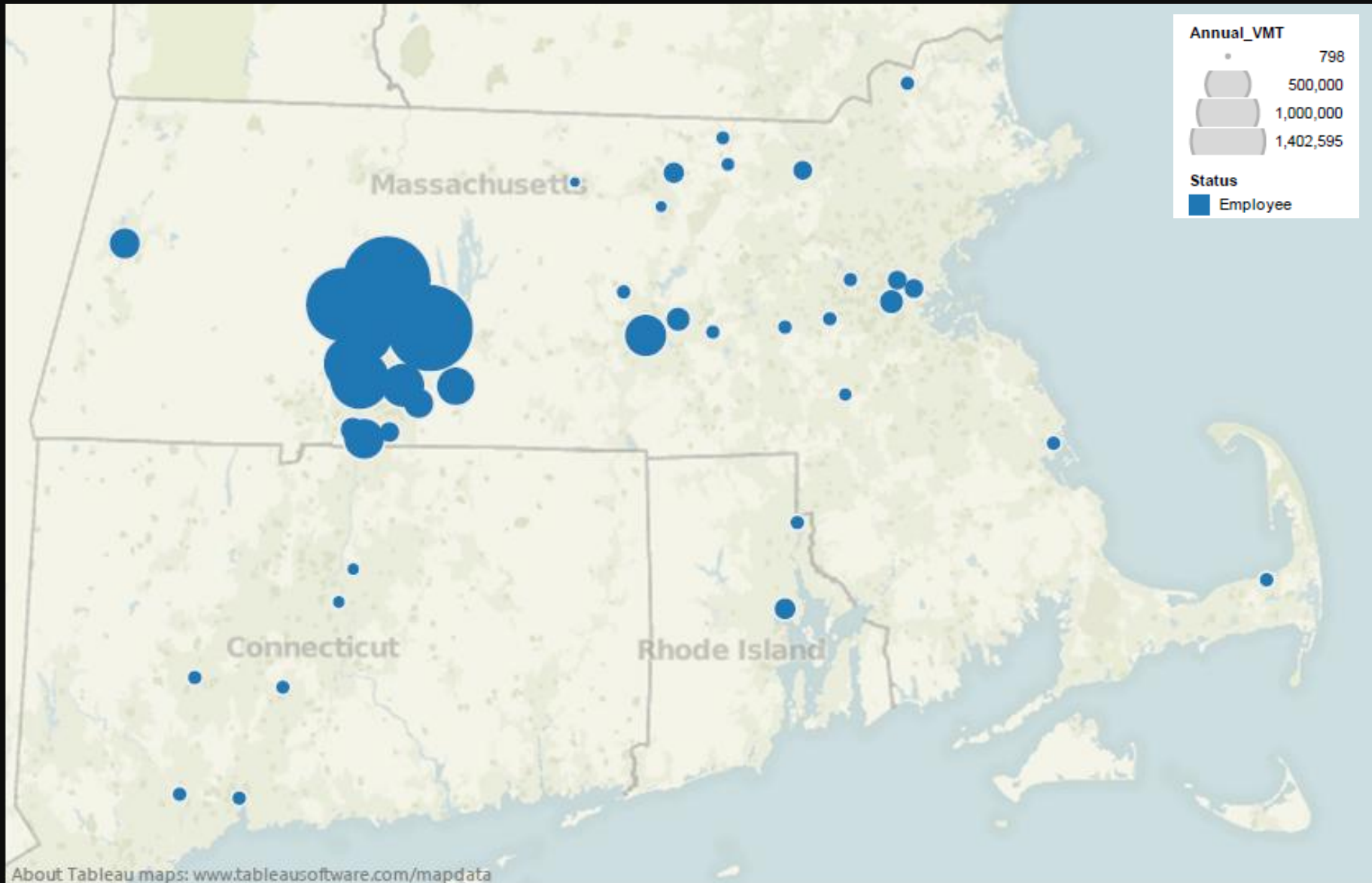

UMASS STUDENT VEHICLE MILEAGE TRAVEL

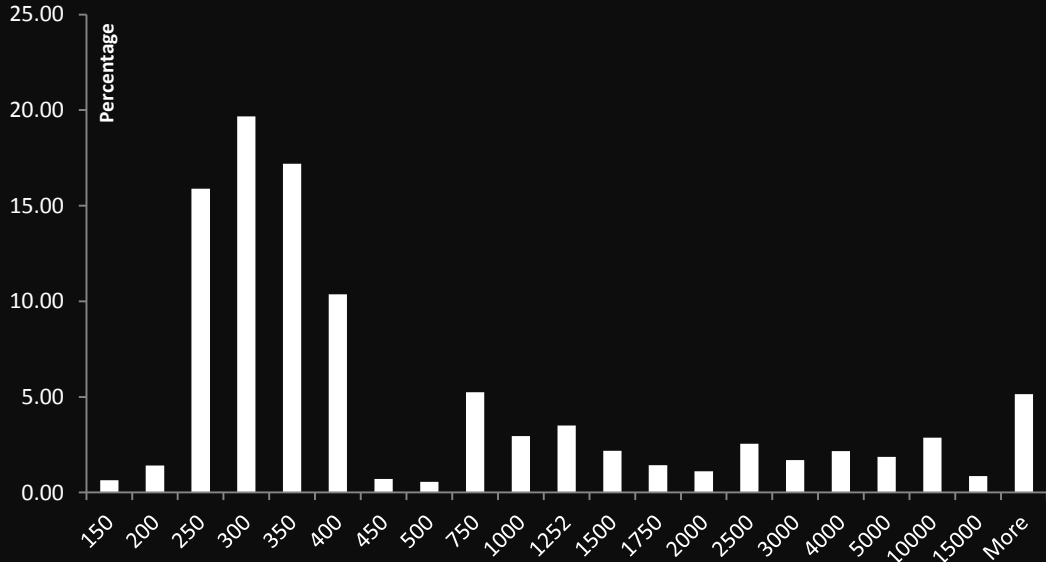
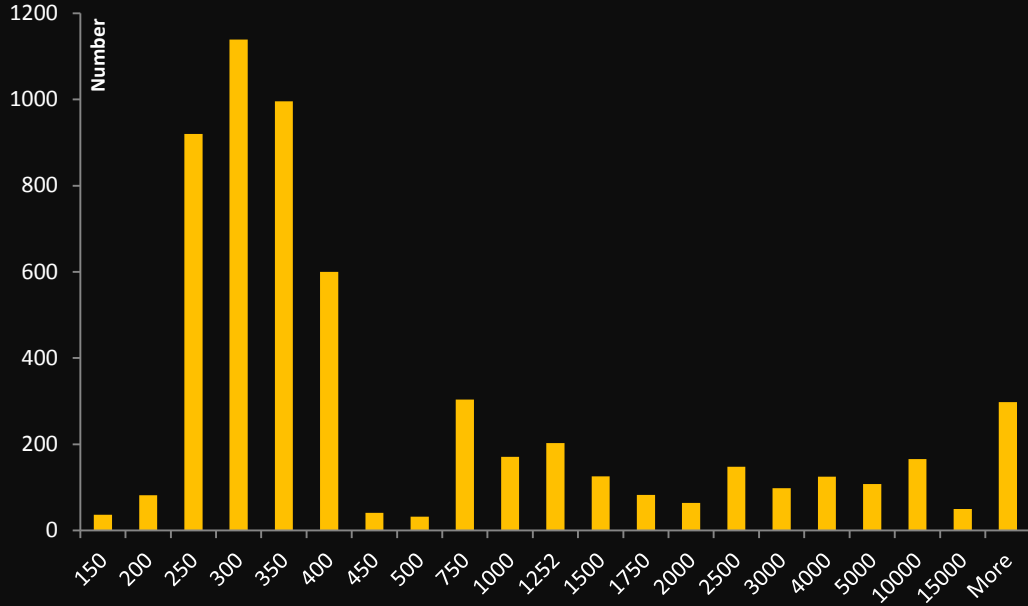

UMASS STUDENT VEHICLE MILLAGE TRAVEL

<i>Annual_VMT</i>	<i>Frequency</i>	<i>Percentage</i>
150	37	0.64
200	82	1.42
250	920	15.89
300	1139	19.67
350	996	17.20
400	600	10.36
450	41	0.71
500	32	0.55
750	304	5.25
1000	171	2.95
1252	203	3.51
1500	126	2.18
1750	83	1.43
2000	64	1.11
2500	148	2.56
3000	98	1.69
4000	125	2.16
5000	108	1.86
10000	166	2.87
15000	50	0.86
More	298	5.15
Total	5791	100

Median Annual VMT :

303 Miles

Average Ann VMT:

1,877 Miles

Max Ann VMT:

18,253 Miles

Min Ann VMT:

13.48 Miles

Total Ann VMT:

10,872,154 Miles

10,872,154 Miles = **436** times around the Earth

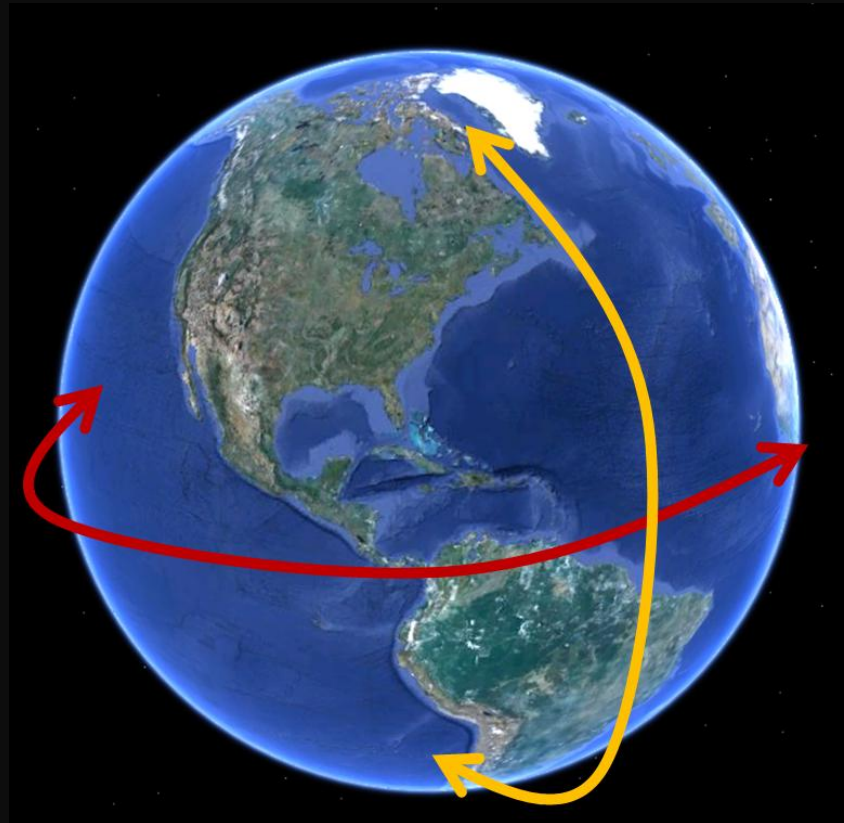

UMASS STUDENT VEHICLE MILLAGE TRAVEL

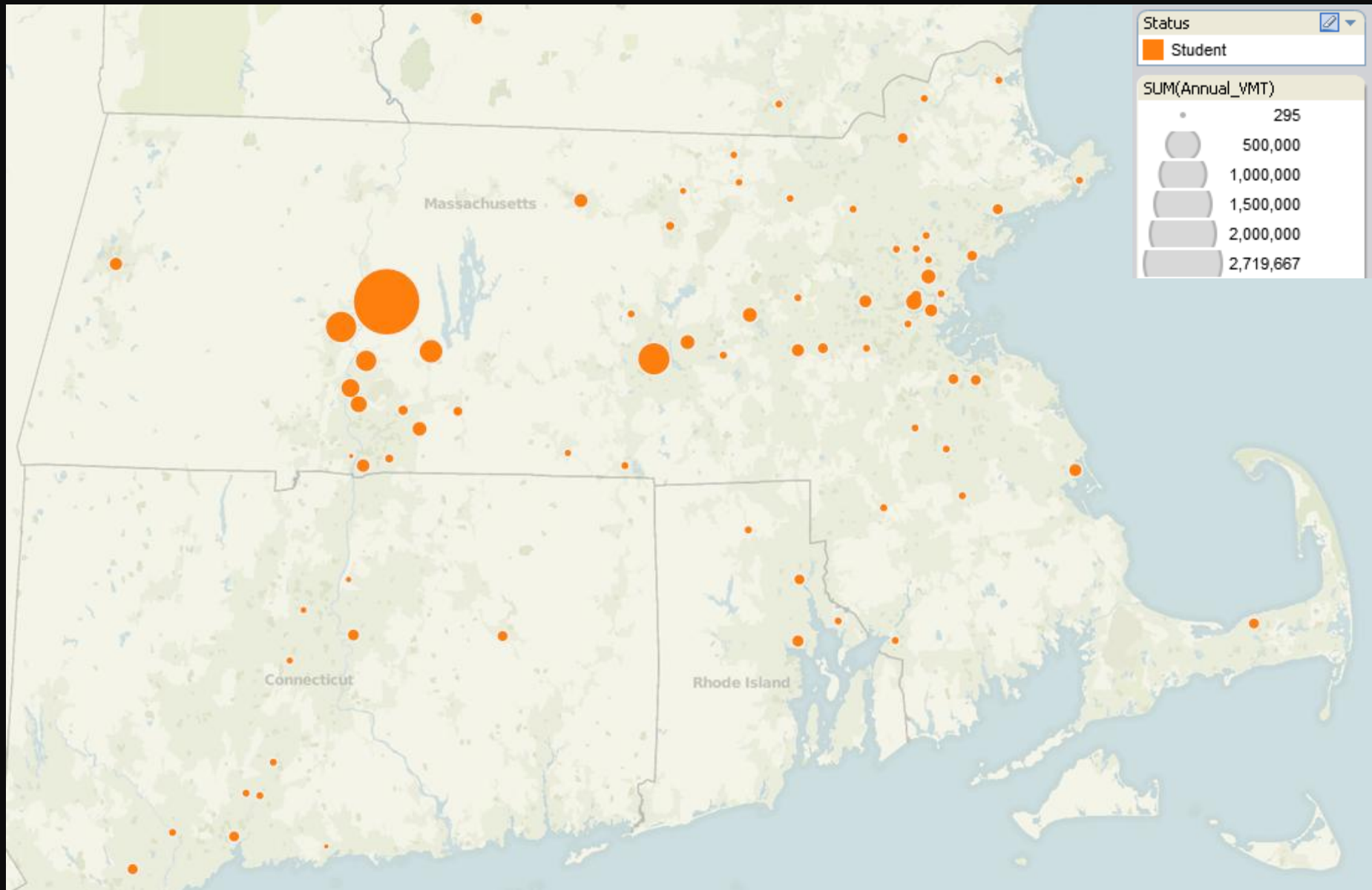

UMASS VEHICLE MILLAGE TRAVEL

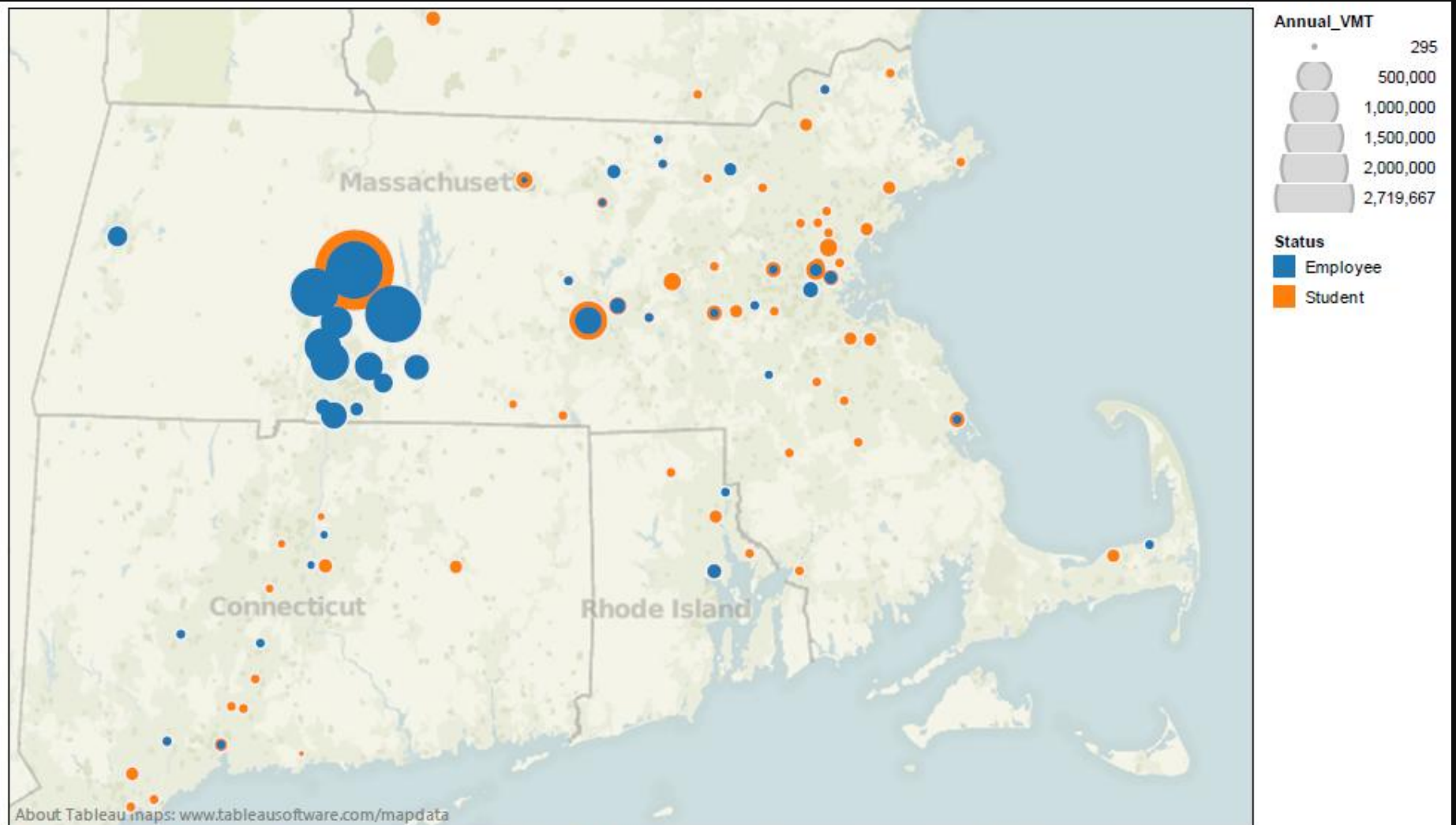

Map based on Longitude (generated) and Latitude (generated). Color shows details about Status. Size shows sum of Annual_VMT. Details are shown for city.

UMASS VEHICLE MILLAGE TRAVEL (Based on Town)

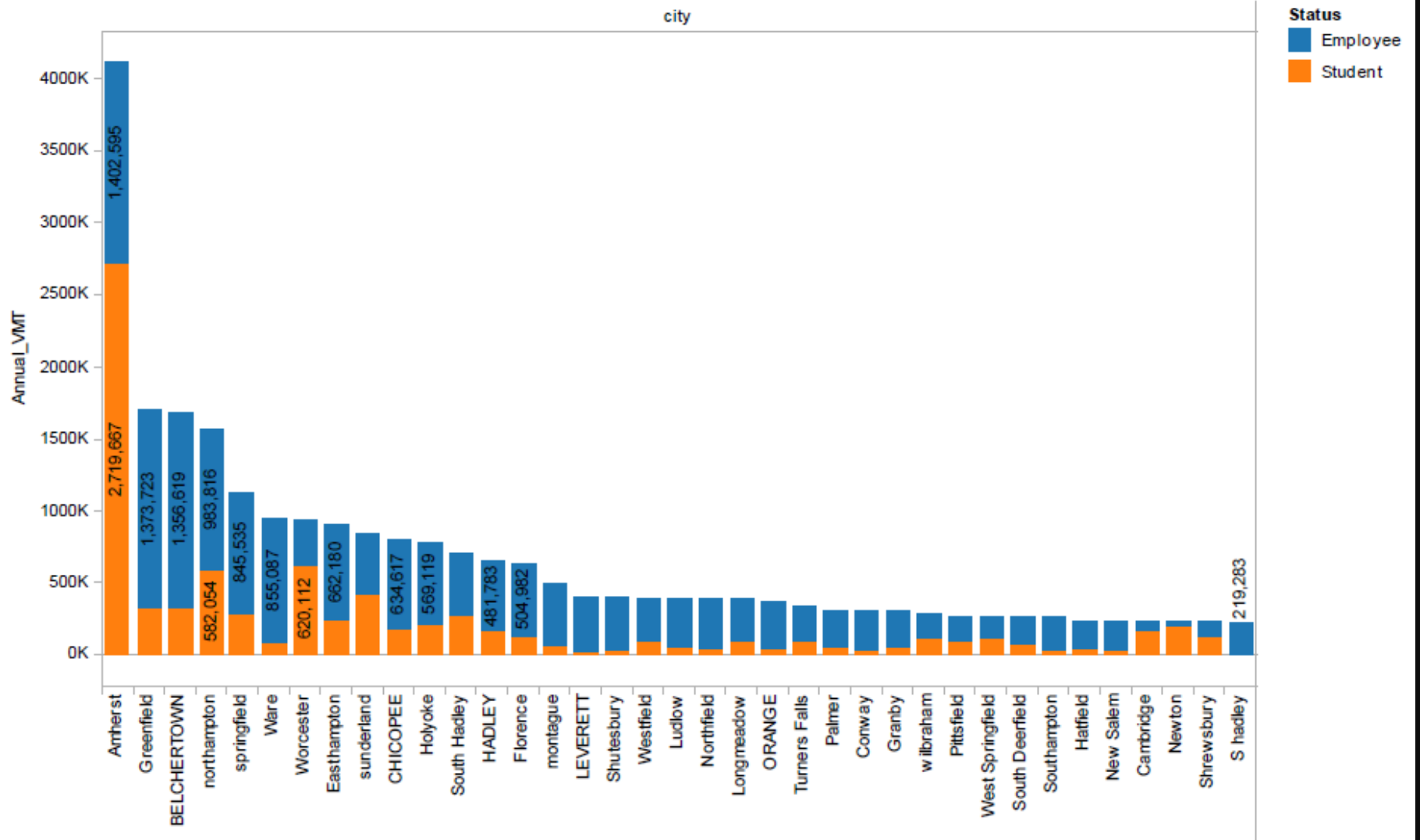

Sum of Annual_VMT for each city. Color shows details about Status.

GHG GENERAL CALCULATION

$$\begin{aligned} &8.92 \times 10^{-3} \text{ metric tons CO}_2/\text{gallon gasoline} \times \\ &35,051,314 \text{ VMT (total)} \times \\ &1/21.5 \text{ miles per gallon for car/truck average} \\ &\quad \text{Divided by} \\ &0.985 \text{ metric tons CO}_2/\text{gallon gasoline} \end{aligned}$$

14,763 Metric Tons per year

Energy of 760 Homes /year

Electricity of 2,210 Homes/year

34,333 Barrels of Oil/year

EPA Optional Emissions from Commuting, Business Travel and Product Transport - Climate Leaders Greenhouse Gas Inventory Protocol

Table 1: Emission Factors for Passenger Vehicle Business Travel (vehicle-mile)

Vehicle Type	CO ₂ Emission Factor (kg CO ₂ /vehicle-mile)	CH ₄ Emission Factor (g CH ₄ /vehicle-mile)	N ₂ O Emission Factor (g N ₂ O/vehicle-mile)
Car	0.364	0.031	0.032
Light-duty Truck	0.519	0.036	0.047
Motorcycle	0.167	0.070	0.007

Equation 1: Passenger Vehicle Business Travel Emissions (vehicle-mile)

$$E = \text{VMT} * (\text{EF}_{\text{CO}_2} + \text{EF}_{\text{CH}_4} * 0.021 + \text{EF}_{\text{N}_2\text{O}} * 0.310)$$

where:

E = Total CO₂-equivalent Emissions

VMT = Vehicle Miles Traveled

EF_{CO2} = CO₂ Emission Factor

EF_{CH4} = CH₄ Emission Factor

EF_{N2O} = N₂O Emission Factor

0.021 = Conversion Factor

0.310 = Conversion Factor

Methodology for Calculating Air Travel Emissions

Dataset – Departmental and Individual

Hierarchy Level 4 Name	MCC	MCC Description	Sales Tax	Source Amount	Transaction Post Date	Depart Travel Date	Dest City	Fare Base	Orig City	Passenger Name	Service Class	Tkt Number	Metrics
AMHERST TRAVEL	3000	United Airlines		-2575	2/18/2013	2/17/2013	DEP	Y/AGYD	HDQ	ADEPOSIT/A	Y/	01623446664755	-2575
AMHERST TRAVEL	3000	United Airlines		-1500	4/5/2013	3/10/2013	DEP	Y/AGYD	HDQ	ADEPOSIT/A	Y/	01623523121032	-1500
AMHERST TRAVEL	3000	United Airlines		-1250	5/14/2013	3/17/2013	DEP	Y/AGYD	HDQ	ADEPOSIT/A	Y/	01623518347732	-1250
AMHERST TRAVEL	3000	United Airlines		-1082.36	10/19/2012	10/27/2012	BDL	VA7FN	ORD	LEE/PATRICK	V	01671404678602	-1082.36
AMHERST TRAVEL	3000	United Airlines		-1082.36	10/19/2012	10/27/2012	ORD	VA7FN	YYC	LEE/PATRICK	V	01671404678602	-1082.36
AMHERST TRAVEL	3000	United Airlines		-1082.36	10/19/2012	10/29/2012	YUL	V7Q8TP	BDL	LEE/PATRICK	V	01671404678602	-1082.36
AMHERST TRAVEL	3000	United Airlines		-1082.36	10/19/2012	10/29/2012	YYC	V7Q8TP	YUL	LEE/PATRICK	V	01671404678602	-1082.36
AMHERST TRAVEL	3000	United Airlines		-706.8	4/20/2012	4/26/2012	BDL	TXA7NJ	DCA	BROWN/DEVON	T	01670537284710	-706.8
AMHERST TRAVEL	3000	United Airlines		-706.8	4/20/2012	4/26/2012	DCA	TXA7NJ	PHX	BROWN/DEVON	T	01670537284710	-706.8
AMHERST TRAVEL	3000	United Airlines		-706.8	4/20/2012	4/26/2012	PHX	TXA7NJ	OAK	BROWN/DEVON	T	01670537284710	-706.8
AMHERST TRAVEL	3000	United Airlines		-706.8	4/20/2012	4/29/2012	CLE	VA7KN	BDL	BROWN/DEVON	V	01670537284710	-706.8
AMHERST TRAVEL	3000	United Airlines		-706.8	4/20/2012	4/29/2012	DEN	VA7KN	OAK	BROWN/DEVON	V	01670537284710	-706.8
AMHERST TRAVEL	3000	United Airlines		-706.8	4/20/2012	4/29/2012	OAK	VA7KN	DEN	BROWN/DEVON	V	01670537284710	-706.8
AMHERST TRAVEL	3000	United Airlines		-697.2	2/15/2013	2/7/2013	LAX	LA14FN	YVR	MADAIKY/AARON	LA	01623490236362	-697.2

Dataset – Esri US Airports Map

ObjectID *	Shape *	NAME	FCC	LOC_ID	USE	OWNERNAME
0	Polygon	Talkeetna Airport	D58	TKA	PU	
1	Polygon	Hooper Bay Airport	D58	HPB	PU	
2	Polygon	Unalaska Airport	D58	DUT	PU	
3	Polygon	Point Hope Airport	D58	PHO	PU	
4	Polygon	Gambell Airport	D58	GAM	PU	St Of Ak Dotpf/N Region
5	Polygon	Nome Airport	D58	OME	PU	St Of Ak Dotpf North Reg
6	Polygon	Shishmaref Airport	D58	SHH	PU	State Of Ak Dotpf N Rgn
7	Polygon	Edward G Pitka Sr Airport	D58	GAL	PU	St Of Alask Doptf North Reg
8	Polygon	Ralph Wien Memorial Airport	D58	OTZ	PU	
9	Polygon	Selawik Airport	D58	WLK	PU	
10	Polygon	Wiley Post-Will Rogers Memorial Airport	D58	BRW	PU	
11	Polygon	Wainwright Airport	D58	AWI	PU	
12	Polygon	Cold Bay Airport	D58	CDB	PU	State Of Ak Dotpf-Central Rgn
13	Polygon	Sand Point Airport	D58	SDP	PU	
14	Polygon	King Salmon Airport	D58	AKN	PU	
15	Polygon	Bethel Airport	D58	BET	PU	State Of Ak Dotpf-Central Rgn
16	Polygon	McGrath Airport	D58	MCG	PU	
17	Polygon	Dillingham Airport	D58	DLG	PU	State Of Ak Dotpf-Central Rgn
18	Polygon	Emmonak Airport	D58	EMK		
19	Polygon	Homer Airport	D58	HOM	PU	State Of Ak Dotpf-Central Rgn
20	Polygon	Soldotna Airport	D58	SXQ	PU	City Of Soldotna
21	Polygon	Kodiak Airport	D58	ADQ	PU	
22	Polygon	Kenai Municipal Airport	D58	ENA	PU	
23	Polygon	Elmendorf AFB	D58	EDF	PR	
24	Polygon	Merrill Field Airport	D58	MRI	PU	
25	Polygon	Campbell Airstrip	D58	CSR	PR	
26	Polygon	Ted Stevens Anchorage International Airport	D58	ANC	PU	
27	Polygon	Northway Airport	D58	ORT	PU	State Of Alaska Dotpf/N. Rgn
28	Polygon	Merle K Mudhole Smith Airport	D58	CDV	PU	Dot Nothern Region
29	Polygon	Gulkana Airport	D58	GKN	PU	St Of Ak Dotof Nor Reg

Campus Carbon Calculator (CO2 Emission factors)

Fiscal Year	MMBtu / passenger mile	kg CO ₂ / mile	kg CH ₄ / mile	kg N ₂ O / mile
1990	0.004766563	0.915466074	9.21535E-06	1.05924E-05
1991	0.004536137	0.871210476	8.76986E-06	1.00803E-05
1992	0.004413371	0.84763205	8.53252E-06	9.80749E-06
1993	0.004457418	0.856091779	8.61768E-06	9.90537E-06
1994	0.004344826	0.834467317	8.4E-06	9.65517E-06
1995	0.004282079	0.819872594	8.27869E-06	9.51573E-06
1996	0.004095891	0.798821716	7.91872E-06	9.10198E-06
1997	0.004091169	0.797900734	7.90959E-06	9.09149E-06
1998	0.00388095	0.756901694	7.50317E-06	8.62433E-06
1999	0.004009144	0.781903342	7.75101E-06	8.90921E-06
2000	0.003892236	0.759102716	7.52499E-06	8.64941E-06
2001	0.003848188	0.750512019	7.43983E-06	8.55153E-06
2002	0.003607876	0.703644097	6.97523E-06	8.0175E-06
2003	0.003492953	0.681230677	6.75304E-06	7.76212E-06
2004	0.003407854	0.664633774	6.58852E-06	7.57301E-06
2005	0.003231973	0.630331682	6.24848E-06	7.18216E-06
2006	0.003141605	0.612707309	6.07377E-06	6.98135E-06
2007	0.003040058	0.59290244	5.87744E-06	6.75568E-06
2008	0.002936042	0.572616204	5.67635E-06	6.52454E-06
2009	0.002774477	0.541106325	5.36399E-06	6.16551E-06
2010	0.002690893	0.52480488	5.20239E-06	5.97976E-06
2011	0.002690893	0.52480488	5.20239E-06	5.97976E-06
2012	0.002690893	0.52480488	5.20239E-06	5.97976E-06
2013	0.002690893	0.52480488	5.20239E-06	5.97976E-06

Dataset – Great Circle Mapper



BDL - Airport

[Map](#)[Distance](#)[Search](#)[Airport Info](#)

Detailed information for an airport code

[FAQ](#)
[Featured Maps](#)
[More](#)
[Home](#)

Location

City: Windsor Locks, Connecticut, United States
Near (Alt.): Hartford, Springfield
Name: Bradley International Airport
ICAO / IATA: [KBDL](#) / [BDL](#)
FAA: [BDL](#)

Details

Type: Airport ([Part 139 Class I](#))
Use: Public/Civil, International (customs port of entry)
Latitude: 41°56'21"N (41.939145)
Longitude: 72°41'00"W (-72.683370)
Datum: WGS 1984
Elevation: 173 ft (53 m)
Runways: 3
Longest: 9510 × 200 ft (2899 × 61 m), paved

Time

Time Zone: UTC-5 (DST-4)
Local Time: 04 Dec 2013 12:43 EST

Weather

METAR: KBDL 041651Z 00000KT 10SM BKN120 BKN250 06/M02 A3010 RMK AO2 SLP193 T00611022
TAF: KBDL 041141Z 0412/0518 00000KT P6SM FEW030 BKN120
FM041700 00000KT P6SM SCT070
FM050400 00000KT P6SM BKN040
FM050800 00000KT 5SM BR BKN025
FM051100 VRB03KT 3SM -DZ BR BKN010

Related Locations

Nearby: [United States \(US\)](#)
Farthest: [MGV: 11738 mi / 18891 km](#)
[Margaret River, WA, AU](#)

Find:

beyond
but within



- [Location](#)
- [Details](#)
- [Time](#)
- [Weather](#)
- [Related Locations](#)
- [Other Information](#)
- [Airport Diagram](#)
- [Sectional Chart](#)
- [Satellite Image](#)

Taxi Bradley Airport

www.aaacab.net

All Airports No Local pay cash
Get 10% Off Bradley Int'l
Airport



Airport Diagram

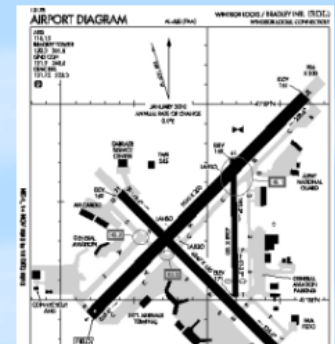

PROJECT METHOD

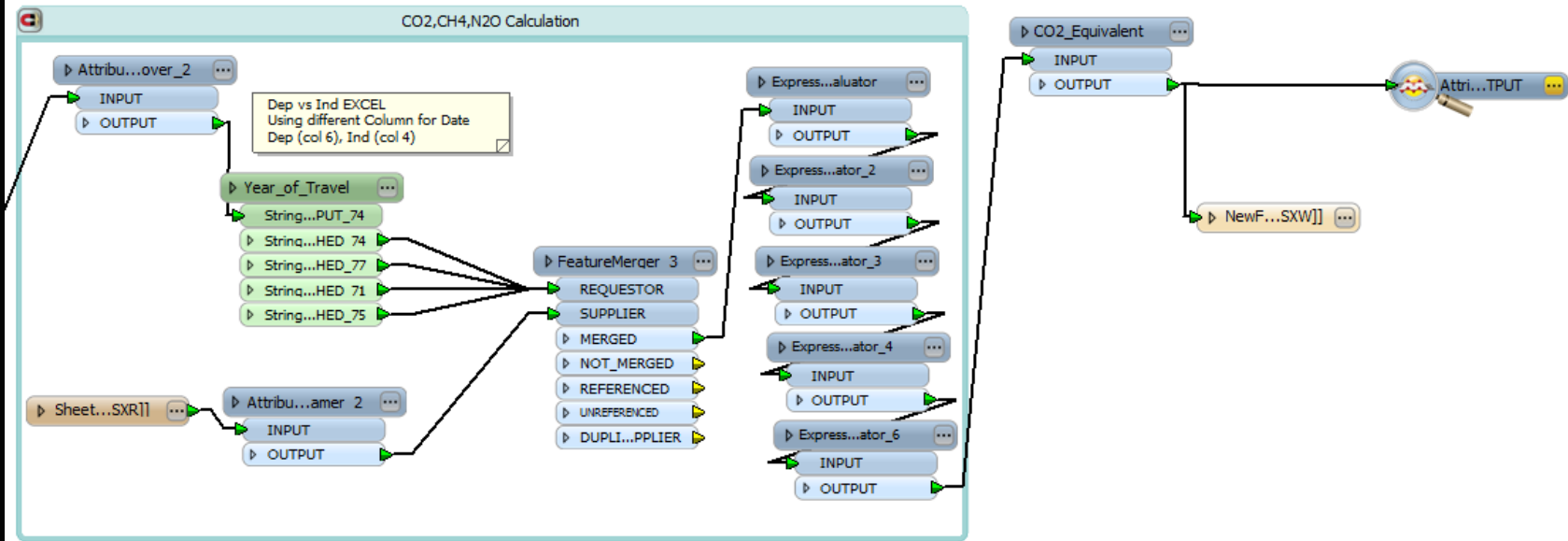

Fiscal Year	MMBtu / passenger mile	kg CO ₂ / mile	kg CH ₄ / mile	kg N ₂ O / mile
1990	0.004766563	0.915466074	9.21535E-06	1.05924E-05
1991	0.004536137	0.871210476	8.76986E-06	1.00803E-05
1992	0.004413371	0.84763205	8.53252E-06	9.80749E-06
1993	0.004457418	0.856091779	8.61768E-06	9.90537E-06
1994	0.004344826	0.834467317	8.4E-06	9.65517E-06
1995	0.004282079	0.819872594	8.27869E-06	9.51573E-06
1996	0.004095891	0.798821716	7.91872E-06	9.10198E-06
1997	0.004091169	0.797900734	7.90959E-06	9.09149E-06

Air Travels (Airports-Origin)

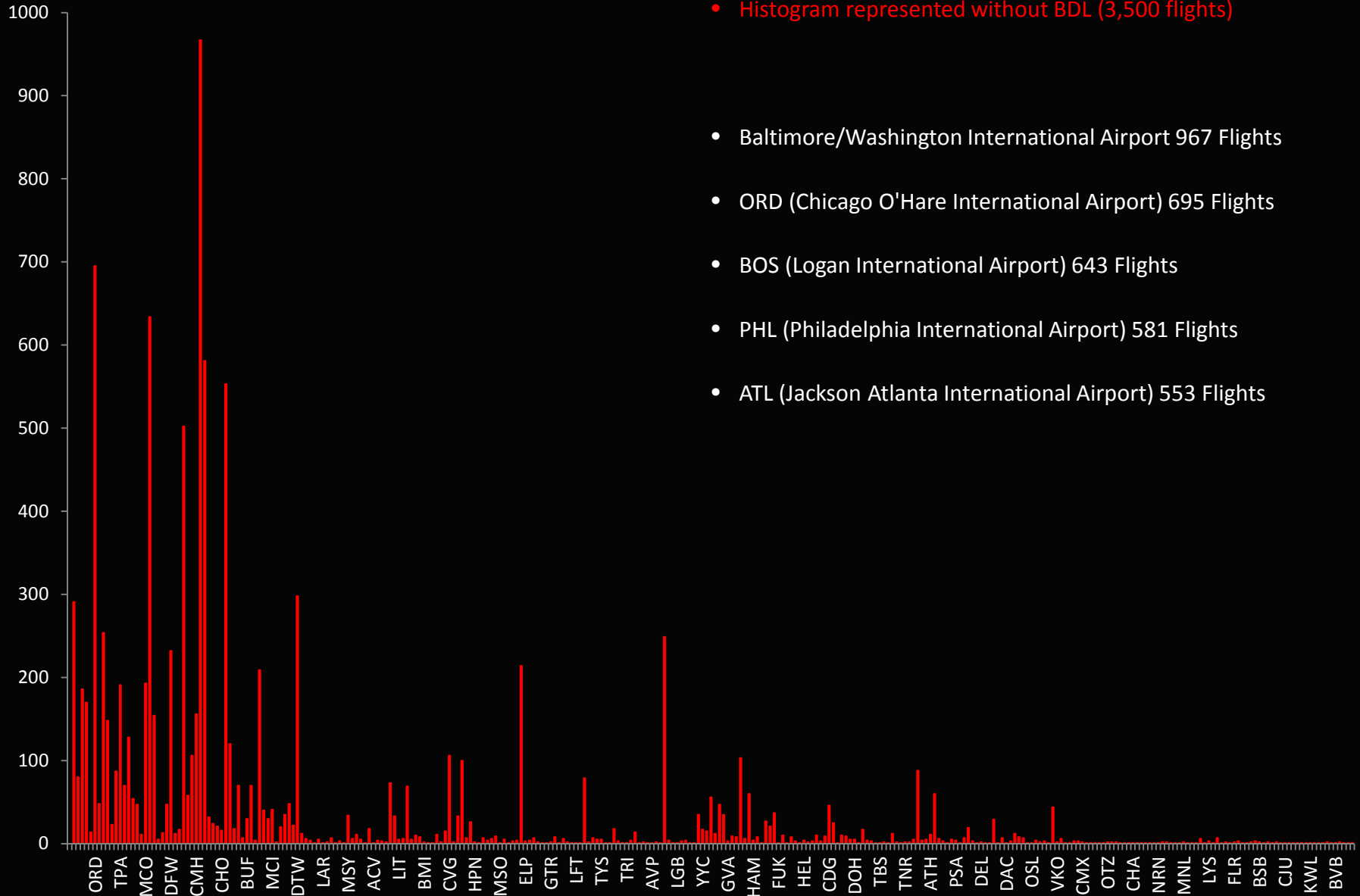

Air Travels (Airports-Destination)

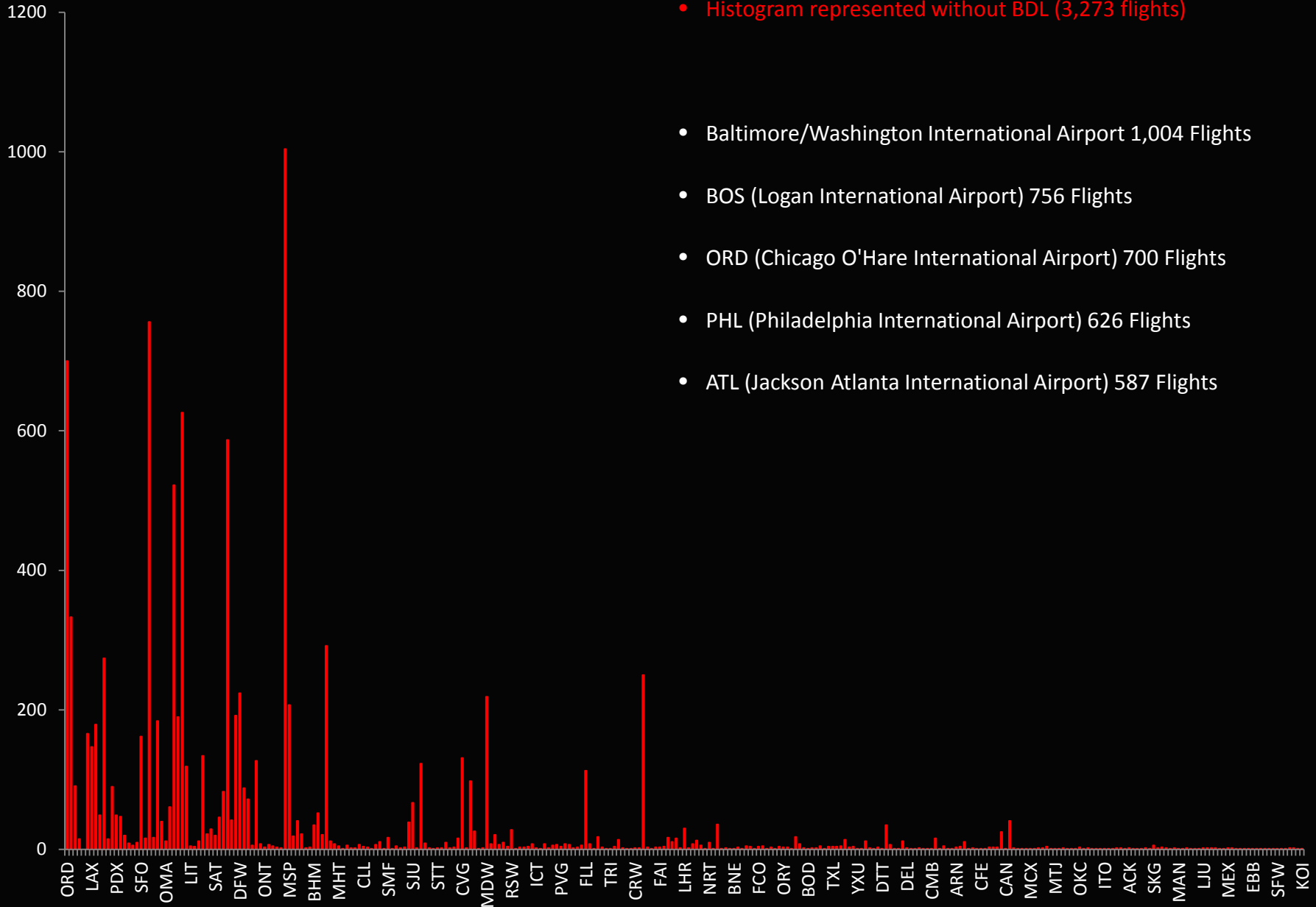

- Histogram represented without BDL (3,273 flights)
- Baltimore/Washington International Airport 1,004 Flights
- BOS (Logan International Airport) 756 Flights
- ORD (Chicago O'Hare International Airport) 700 Flights
- PHL (Philadelphia International Airport) 626 Flights
- ATL (Jackson Atlanta International Airport) 587 Flights

Total Number of personal departmental Flights 15,896 (13,629 analyzed)

Average GHG emission produced per person Air Travel 0.9014 tons of CO₂e

Median of GHG emission produced by each Air Travel 0.6181 tons of CO₂e

Max of GHG emission 12.33 tons of CO₂e

Min of GHG emission 0.021 tons of CO₂e

Total GHG emission from Air Travel 12,285 tons of CO₂e

CO₂e produced by Air Travels

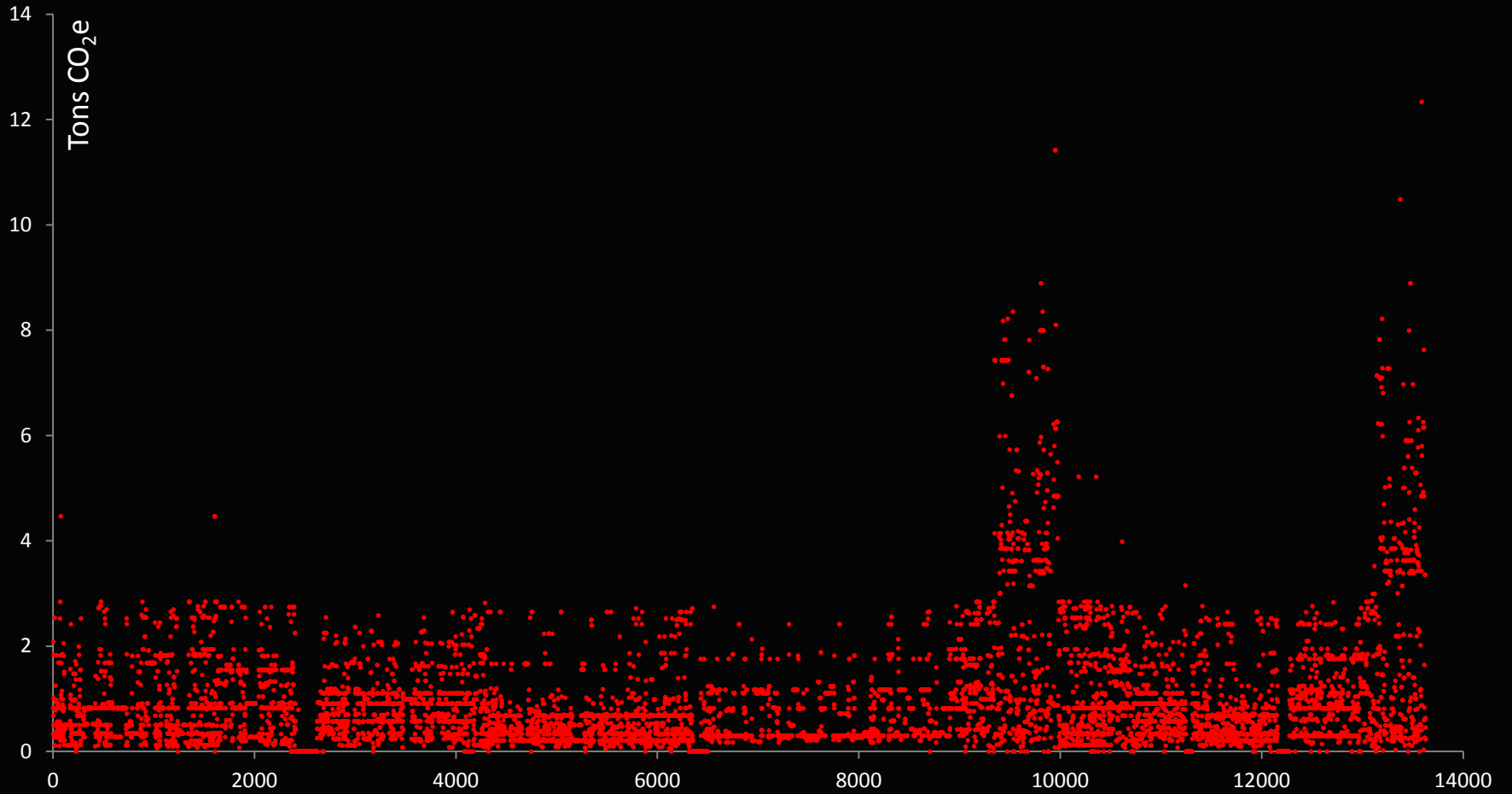

CO₂e produced by Air Travels

