

2010

# University of Massachusetts Amherst Libraries Master Plan

Shirley Dugdale

*Dugdale Strategy LLC, shirley@dugdalestrategy.com*

Gerald Jay Schafer

*University of Massachusetts - Amherst, jschafer@library.umass.edu*

Bryan Harvey

*University of Massachusetts - Amherst, harvey@provost.umass.edu*

James Cahill

*University of Massachusetts - Amherst, j.cahill@neu.edu*

Ludmilla Pavlova-Gillham

*University of Massachusetts - Amherst, lpavlova@cp.umass.edu*

*See next page for additional authors*

Follow this and additional works at: [https://scholarworks.umass.edu/cp\\_reportsplans](https://scholarworks.umass.edu/cp_reportsplans)

 Part of the [Architectural Engineering Commons](#), [Architectural History and Criticism Commons](#), [Architectural Technology Commons](#), [Construction Engineering Commons](#), [Cultural Resource Management and Policy Analysis Commons](#), and the [Urban, Community and Regional Planning Commons](#)

---

Dugdale, Shirley; Schafer, Gerald Jay; Harvey, Bryan; Cahill, James; Pavlova-Gillham, Ludmilla; Button, Leslie Horner; Warner, Theresa; Rooney, Pam; and Cunningham, John, "University of Massachusetts Amherst Libraries Master Plan" (2010). *Campus Planning Reports and Plans*. 5.

Retrieved from [https://scholarworks.umass.edu/cp\\_reportsplans/5](https://scholarworks.umass.edu/cp_reportsplans/5)

This Article is brought to you for free and open access by the Campus Planning at ScholarWorks@UMass Amherst. It has been accepted for inclusion in Campus Planning Reports and Plans by an authorized administrator of ScholarWorks@UMass Amherst. For more information, please contact [scholarworks@library.umass.edu](mailto:scholarworks@library.umass.edu).

---

**Authors**

Shirley Dugdale, Gerald Jay Schafer, Bryan Harvey, James Cahill, Ludmilla Pavlova-Gillham, Leslie Horner Button, Theresa Warner, Pam Rooney, and John Cunningham



# UNIVERSITY OF MASSACHUSETTS AMHERST LIBRARIES MASTER PLAN

## FINAL REPORT

DEGW North America with Livermore Edwards Associates  
18 November 2010







# UNIVERSITY OF MASSACHUSETTS AMHERST LIBRARIES MASTER PLAN

## FINAL REPORT

Prepared for the University of Massachusetts Amherst  
Office of Campus Planning and Facilities Planning

by  
DEGW North America with Livermore Edwards Associates  
18 November 2010

# TABLE OF CONTENTS

1	Executive Summary	1.1 -1.27
2	Project Background, Goals and Process	2.1 - 2.9
3	Existing Facilities Constraints and Opportunities	3.1 - 3.36
4	A Future Vision for the UMass Amherst Libraries	4.1 - 4.21
5	Space Needs Assessment	5.1 - 5.28
6	Space Strategies for the UMass Amherst Libraries	6.1 - 6.19
7	Master Plan Recommendations	7.1 - 7.29
8	Implementation Issues	8.1 - 8.14
9	Appendix 1	
	Appendix 2	

# ACKNOWLEDGEMENTS

## **Project Steering Group**

Jay Schafer, Director of Libraries  
Leslie Button, Assoc. Director for Library Services  
Terry Warner, Assist. Director, Administrative Services  
John Cunningham, Deputy Provost, Dean of Undergrad. Ed.  
Bryan Harvey, Director, Academic Planning & Assessment  
Jim Cahill, Director of Facilities Planning  
Ludmilla Pavlova, Project Manager, Campus Planning  
Pam Rooney, Assist. Director, Space & Asset Management

## **Project Team**

### **DEGW:**

Shirley Dugdale, AIA  
Elliot Felix  
Puja Nanda  
Warren Wong  
James Brucz

### **Livermore Edwards Associates:**

Bob Livermore, AIA  
Brian Amaral  
Andrew Shelburne

Others who contributed to the study and attended workshops included:

The Senior Management Group of the Libraries  
Representatives of the Research Libraries Advisory Council  
Vice Chancellor for Research and Engagement  
Representatives of the Faculty  
Librarians and Library Staff  
Office of Information Technologies  
Learning Commons Staff  
Learning Resources Center Staff  
Teaching Commons Staff  
Undergraduate and Graduate Students

The contribution of all who participated in the many workshops was much appreciated.

# 1 EXECUTIVE SUMMARY

This master plan study was undertaken at an important point in the history of the University of Massachusetts Amherst Libraries, which is on the edge of significant change moving into a new era serving scholars, researchers and learners in the 21st Century.

Over the last decade the Library has been a leader in many initiatives: increasing development of digital resources; collaborating with the Five Colleges Consortium, which was one of the first in the country to develop a shared book depository; developing a highly successful Learning Commons that engages partners in providing a broad range of services and settings for learners; providing services through partners welcomed into library facilities, such the peer learning activities of the Learning Resources Center; and converting space to nontraditional library uses that are compatible with the mission of the library with facilities like the Teaching Commons.

The visioning and conceptual development that was done for this study sought to build on the success of these initiatives, improve library space, and seek new types of blended facilities with partners that could enhance what the library offers the campus community.

The Libraries master plan is aligned with the University's strategic plan to become a major research institution through growth of new areas for research and academic development, and to grow its student body. Whereas the previous decade focused a great deal on supporting undergraduate learning and research, for the next decade the Library plans to improve support for scholars, researchers and graduate students, combined with expanded services for undergraduates. A primary component of this vision is the proposed Research Commons, which could become a model for the comprehensiveness of its co-located services.

The Du Bois tower is in need of major renovation, upgrading to enable new types of activities, as well as to support traditional study and scholarship more effectively. Many options were studied for conversion of spaces to new activities or functions compatible with the library's mission, and these are outlined in the sections that follow. Du Bois tower was the primary challenge: how to find ways to exploit the building's potential yet mitigate its challenges.

# GOALS FOR THE STUDY

## PLANNING/INSTITUTIONAL GOALS

- **Conduct a condition assessment of the Du Bois library** and study deferred maintenance and regulatory requirements affecting future uses
- **Examine existing uses of library facilities and identify underutilized spaces.** Determine what the appropriate size is for existing functions based on university or best practice standards, applying the “right-sizing” evaluation approach used in the Academic Facilities Plan and the Science Facilities Plan
- **Understand what the future growth of the physical collections will be** and examine options for storing them
- **Determine space requirements of potential compatible uses aligned with the library’s mission,** both existing and new
- **Explore how new facilities might help support movement from lecture-based to team-based learning**
- **Identify opportunities to add classrooms,** particularly those in the mid-range, 50 to 80 person capacity
- **Explore opportunities to relocate Research & Engagement offices** to the center of campus
- **Evaluate options for alternative space uses in Du Bois & Lederle** and identify optimum uses for the space
- **Understand phasing issues and associated costs**
- **Develop a master plan that is flexible** and will allow incremental opportunistic projects as funding comes available

## LIBRARY GOALS

- **Develop a vision for revitalizing the Library facilities**
- **Seek strategies to enhance the library as a major campus learning center**
- **Convert underutilized space** into new functions to serve the library’s mission into the 21<sup>st</sup> Century, especially by examining low usage portions of the collections
- **Support advanced research and e-science with new services**
- **Engage partnerships** to achieve integrated services
- **Explore new types of library facilities** that will enhance users learning and study experiences 24/7
- **Plan solutions to enhance the libraries’ staff services** and both efficiency and effectiveness of operations

# LIBRARY VISION SUMMARY

## SERVICES VISION

- **Improve research support by creating a research commons**, bringing specialist librarians together with scholarly communications librarians and developing new types of services, like data curation
- Continue to develop the **Learning Commons**, enriching its offerings as the primary study center on campus
- Continue to **explore partnerships** to offer integrated services and serve the campus more effectively, e.g. supporting the Teaching Commons
- Incorporate the Image Collections and music listening facility as part of a broader range of services to **support use of media collections**
- **Transition more staff from processing of print materials to management of digital resources**

## SPACE VISION

- **Convert underutilized space into new functions**
- **Relieve overcrowded stacks**
- Provide **more teaching facilities** to teach about library resources and digital literacy
- **Find the right balance between quiet individual settings and collaborative settings**
- Find the right balance between centrally scheduled classrooms and ones that can be bookable on demand and managed by the library, and find locations for them so their traffic does not disrupt library functions
- **Create special destinations** to draw users to the libraries

## COLLECTION VISION

- **House the UMass print collections in proper conditions with environmental controls**
- **Plan for adequate space to grow and highlight the Special Collections**
- **Shift underutilized materials** into off-campus storage as appropriate to make room for new uses
- **Consolidate several distributed collections** into Du Bois (e.g. Music listening room)
- **Enable browsing** of the most used portions of the collections and make accessible in Du Bois those collections that benefit most from mediated use
- **Determine a vision for the science & engineering library** in support of developments in e-science

# FINDINGS ABOUT THE DU BOIS LIBRARY BUILDING

- **The very specific nature of the construction of the Du Bois Library tower and the fact that it was built under now outdated provisions of the Building Code makes it problematic to renovate in a major way for other uses. Any major renovation for any portion of the tower will require that the entire building be brought up to code.** This will include the provision of a sprinkler system, an upgrade of the emergency electrical system and modifications to the stair towers to provide emergency smoke evacuation provisions. These upgrades are projected to take 3 years and approximately \$16 million to complete. At this time this work has not been started, but \$13.5 million has been funded.
- The building was originally designed with two floors of book stacks between each carrel floor. **These stack floors have insufficient headroom for most other kinds of occupancies** and are further constrained by the characteristics of their construction.
- **The carrel floors in Du Bois are the only floors suitable to be remodeled for office or other functions.** Each carrel floor, at approximately 7,060 usable square feet, has plumbing capacity for higher occupancies and sufficient headroom for new ductwork and sprinkler systems, and could be renovated pending the completion of the code up-grades for the building. Current usage of the carrel spaces is low.
- **The only “underutilized” space in the library buildings is the enclosed carrels and low usage portions of the collections. More space could be freed up by relocating low usage print materials into storage elsewhere, but alternative locations must be developed first.** To achieve better efficiency of space utilization, the team sought ways to replace quiet seating. The report lays out the options for additional storage.
- **There is no “immediately available” space in the Du Bois tower: freeing up space will require enabling projects for code upgrades, relocation of existing functions or collections, and demolition.** Most of the carrel floors are mixed occupancy, so to convert them to other uses would require relocating any functions there to other floors (e.g. OIT classrooms, Learning Resource Center, library classrooms, etc.)
- **Minimal code upgrades must be done before major floor renovations can be done.** This could take up to five years, to get risers and closets upgraded, etc. It is possible the first of the carrel floors could be cleared and fitted out toward the end of that period (see phasing diagram on page 1.22). It is assumed that other upgrades would be done over time as the building gets renovated in phases (e.g. horizontal distribution of ductwork or electrical wiring depending on floor layout)..

# CODE CONSIDERATIONS FOR RENOVATIONS

## Background

Alterations, renovations, and new construction additions in the Du Bois Tower are regulated by Building Code requirements when certain thresholds are exceeded. Primary among these is the need to provide fire sprinkler protection in the building caused by its “high rise” classification.

### **SPRINKLERING REQUIREMENT TRIGGERS:**

- Change in Use (>15,000 SF – Building Code)
- Substantial Renovation (Sprinkler cost < 15% of cost of proposed renovation)
- Any Change in Use [Discretion of Authority Having Jurisdiction (AHD) – Amherst Fire Department]

**CHAPTER 34 TRIGGERS:** The Building Code (Chapter 34) requires that if a system within a building is up-graded (any non-maintenance work) that the entire system in question must be brought up to meet current Code. Systems in Du Bois that would fall into that category include:

- Emergency Electrical System
- Electrical System
- Heating and Ventilating Systems
- Plumbing

## Considerations

- Any renovation proposed for an existing building is evaluated by the authority having jurisdiction (AHD) as to whether or not the work meets the definition of a “substantial” renovation. These “triggers” are somewhat subjective but the Code officials have the final authority to make these decisions based on guidelines in the Code.
- For Du Bois tower the requirement to install a sprinkler system will depend on the size of the proposed renovation and/or a change in use and/or the opinion of the AHD.
- **If the Library were to stay as a pure Library Occupancy (A3), a use change would not be indicated. If classrooms for college level teaching or university administrative functions are proposed in the building, these would be considered a change in use to a Business Occupancy (B).** The Code indicates that a use change greater than 15,000 SF will require sprinklering the entire building.
- Regardless of the use change, the AHD can also require sprinklering based on the cost of the proposed renovation. Assuming the cost of installing sprinklers in the building would be approximately \$4 million, any renovation that exceeded \$26 million would trigger the requirements to install sprinklers.



# CONSTRAINTS FOR REPURPOSING SPACE

## CODE CONSTRAINTS

- **Meeting code related requirements will involve upgrading all major building systems first because of changed use classification for conversion from library to office space.**
- **Regardless of the use change, the AHD can also consider the size of the proposed renovation as a trigger for installing sprinklers.** In the case of Du Bois the total project cost of installing sprinklers for the building would be approximately \$4 million . If the cost of the renovation exceeds 15% of this amount the installation of the sprinkler system would be required. This would correspond to a construction cost of \$12.6 million or approximately 3 floors of renovation at Du Bois. Any such calculation would have to be approved by the AHD.

## BUILDING CONSTRAINTS

- **Future changes to the library are most easily made in non-tower spaces** and at locations adjacent to the existing Du Bois building.
- **Carrel floors in the tower are limited to about 7,060 usable square feet**, divided into two parts by the core. Research and Engagement could just fit on one floor with some of the meetings space requested located on an adjacent floor, proposed in the master plan as the Research Commons.
- **Carrel floors are separated by a double set of stack levels.** A larger office suite of appr. 10,000 nsf would not all fit on one floor of the tower, and the remainder would have to be located three floors above or below as there is a double floor of stacks in between carrel floors.
- **Toilets are only located on carrel floors in the tower**, as these were originally planned to be the populated floors with the most seating. Repurposing any stack floors as workspace will trigger code requirements to build toilets.
- **In order to keep library operations going during renovation, the sequence of projects needs to be carefully planned** and may affect choices of functions to be in those spaces.

## PRIMARY PROGRAMMATIC FINDINGS

- **The central location of the library and its iconic image make it an obvious place to support other central campus activities that align with the Library’s mission.**
- **The 24/7 operation of the library makes it an ideal location for study seating and functions that can benefit from the after hours accessibility and supervision the library can provide.**
- **Collections stacks are at capacity, but more low usage materials could be put into paged storage if it was made available—which has to be the first step for any repurposing.** The Five College Depository is almost full, including the 250,000 volume allocation to UMass Amherst. The Library is already in the process of identifying bound journals, monographs and other materials that could be put in off-site or basement storage if it could be created. Despite aggressively investing in digital resources, there is still need to retain sufficient collections to support a major research university. The master plan proposes clearing some stacks floors and holding a steady state on-campus browsing collection size into the next decade. Options for storage are described in section 8. Collaboration with the Five College Consortium will likely be the most cost effective approach long term.
- **Support for excellence in research is a primary campus initiative and an important component of the library’s future vision for new types of services for the 21st Century. A Research Commons is a key concept of the Libraries master plan.** It will draw together Library Research & Liaison Services, Scholarly Communications and partners from other areas, such as Research & Engagement. For researchers increasingly involved in data-intensive research, it will develop integrated services for consultation on scholarly communications, copyright and publication issues, data set management and data curation, and potentially data services dealing with statistical analysis, GIS and data visualization in one convenient central location.
- **Library user seating must increase to meet projected campus population growth for both students and faculty.** If the top 3rd floor of ISEL (the low rise bridge connector in Lederle) must be converted to non-library program, the displaced study seating needs to be provided elsewhere, especially as the student population will grow. This may have to be provided in place of proposed compatible uses in Du Bois.

## PROGRAMMATIC FINDINGS, continued

- **The campus has a pressing need for more classroom space and is seeking new types of spaces to promote more active learning modalities. The Library's mission is leading to greater involvement in supporting learning and teaching.** The development of the Learning Commons, Learning Resource Center, computer classrooms and recently the Teaching Commons are expressions of that. The master plan proposes two new learning studios at the Learning Commons level and a demonstration Learning Lab on the second floor for faculty to experiment and teach with librarians. Other existing centrally scheduled computer classrooms in the library managed by OIT are proposed to be consolidated lower in the building and renovated. The plan increases classroom space in the library by 70% from 8,365 sf to 14,193 sf.
- **Although the Library has already integrated a great deal of compatible uses aligned with its mission into Du Bois, the master plan proposes increasing that by an additional 65%.** This would be achieved primarily by repurposing carrel floors and collections areas.
- **The ISEL facility is an ideal location to provide convenient consultative services to the science and engineering community.** Its consultative, collaborative and study facilities there should be supported and enhanced despite its diminishing need for book storage there. Its convenient location on the connector bridge between Lederle buildings can enhance its effectiveness as a collaborative commons supporting innovation in e-science.

# PROGRAM ANALYSIS SUMMARY

The program analysis summarized existing space in the Du Bois and Lederle buildings, developed a “right sized” program based on standardization of space allocations, and developed a 10 year projection for future space needs to 2020.

The existing buildings’ space program types consist of Library functions like space for staff, collections and user spaces for individual study and collaborative work, the Learning Commons, library classrooms and meeting space, in addition to stacks for the collections. Existing compatible uses include the Learning Resources Center, registrar scheduled computer classrooms managed by OIT, and other functions.

The “right sizing” exercise demonstrated that the library is using its space quite efficiently now, except for the carrel floors because the enclosed carrels have very low usage. Other spaces are to capacity or intensely used and need to be expanded, such as collections storage and the cafe. There are few efficiencies of space use to be gained except by conversion of space to more intensive uses, such as by introducing more commons areas.

The proposed future space needs were then tested for fit against the existing available space in a stacking analysis, once code related layout changes were identified.

## **Key reference pages for further information on program analysis:**

For summary of existing library system, see page 3.4.

For summary of existing uses, see page 5.4.

For print collections projections, see page 5.11-5.16.

For summary of proposed compatible uses to be incorporated into library facilities space, see page 5.21.

For summary comparison of existing and future estimated space needs, see page 5.27-5.28 (with breakdown detail sheets in Appendix 1).

For Du Bois stacking analysis illustrating fit of projected program needs within existing space, see page 7.17-7.20.

For ISEL stacking analysis illustrating fit of projected program needs within existing space, see page 7.23.

For space program breakdown detail listed by room, see Appendix 1.

# SHIFTING SPACE USAGE

One of the intents of the plan was to develop new kinds of collaborative facilities and develop settings for integrated services with partners to meet the research and learning needs of university in the 21<sup>st</sup> century.

In the diagrams here, Library space needs are represented by the combination of Library space and commons areas which offer integrated services, such as the Learning Commons. Library functions are proposed to shift from 38% to 25% of the space, while the proportion that is commons area increases from 10% to 22% with the addition of the Research Commons, the Media Hub and other new facilities to serve the growing student population.

Stack space for collections is proposed to decrease from 43% to 37% while still accommodating 10 years of growth in combination with an off-site storage strategy.

Space to accommodate other compatible uses has been developed in the plan, increasing the proportion from 9% to 16% of the total space.

Note: The existing area totals on the summary table also include current space allocations for the compatible uses being proposed to be integrated into the existing library space, for comparison with projected line items, and is a composite of existing Du Bois, ISEL and Goodell 2<sup>nd</sup> floor spaces. The charts here do not include those existing compatible uses so as to represent the total of the library space more accurately, but do include the new compatible uses in the projected space.

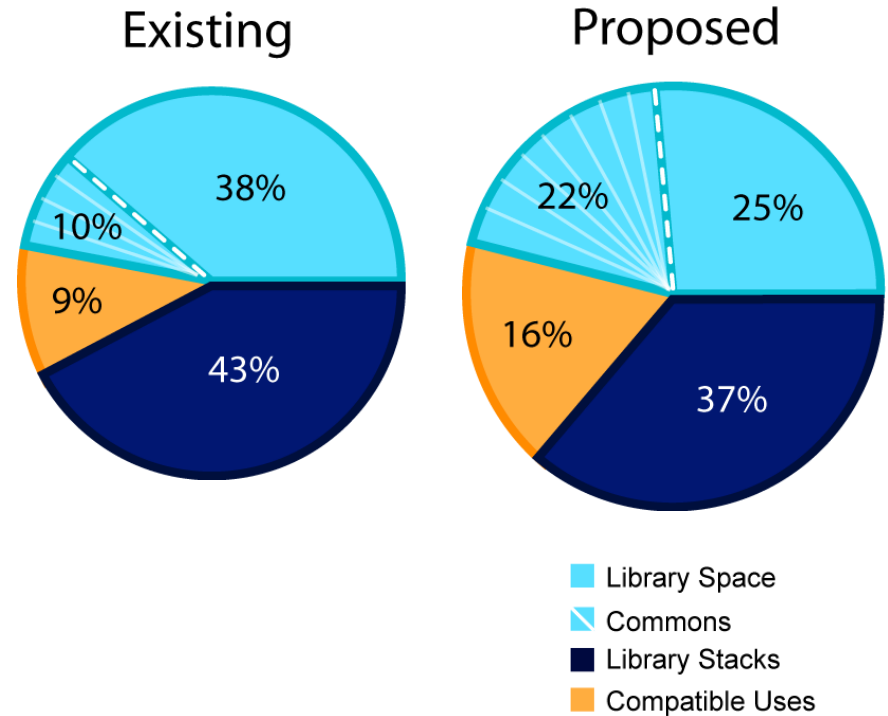

# COLLECTIONS ACCOMMODATION STRATEGY

In order to accommodate the projected growth in the collections, off-site storage capacity will have to be increased. **A portion of the existing Du Bois collections could be reallocated into off-site storage** if available, removing 20% of monographs, 30% of journals and 100% of the print Government Documents, which would be payable on demand. With additional capacity from this relocation, or with the possibility of additional on-campus compact shelving in Du Bois basement or Goodell, the growth in both the General Collections and Special Collections & University Archives can be accommodated despite the repurposing of stack areas in the Du Bois tower to other uses. Expansion of the Five College Depository will require coordinated funding and decision making, whereas on-campus options may provide greater flexibility for UMass. Over time the Depository may be the most cost effective solution. (For further details, see page 6.4)

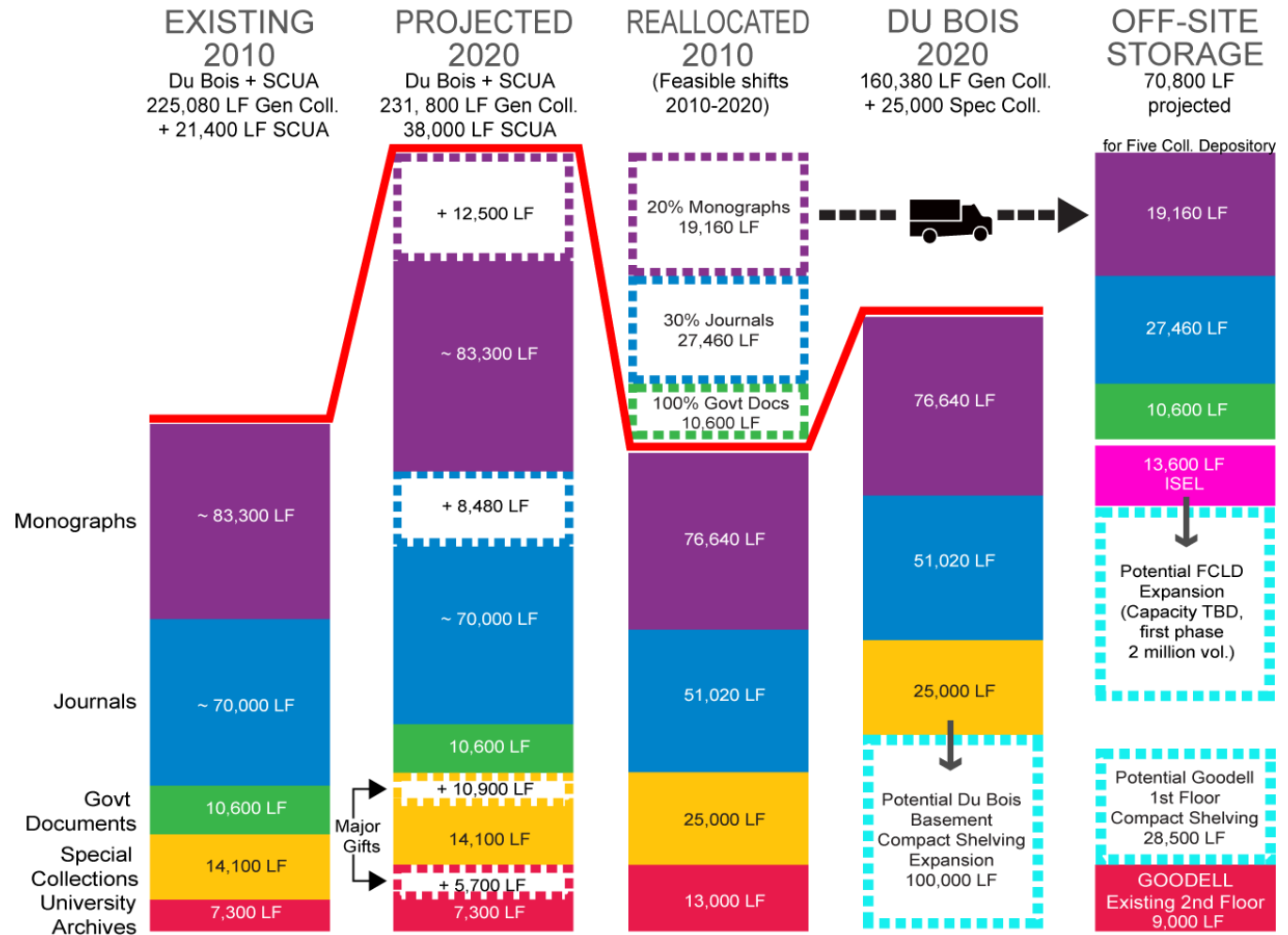



# CONCEPTS FOR NEW FACILITIES

The library vision generated concepts for new types of facilities that would bring together activities to create special active hubs to support innovation and learning. (See page 6.10-19)

**Research Commons** – a consultation hub for research-related resources, scholarly communications, data curation and services for IP/grant management



Cisco Telepresence



Johns Hopkins



Steelcase

**Research / Science Commons**

**Graduate Hub**

**Teaching Commons**

**Science Commons** – a variation on the Research Commons tailored to the special needs of science and engineering researchers and learners

**Graduate Hub** – a quiet place to work individually and to connect with peers

**Teaching Commons** – a central consultation hub to promote new ways of teaching

**Media Hub** – a central place on campus to work with library resources and staff to enhance digital scholarship



Apple Store "Genus Bar"

**Media Hub**



Rotman School of Business

**Colloquium Center**



Stanford

**Learning Labs**

**Learning Labs** – experimental teaching spaces to enable new pedagogies with support services

# RESEARCH COMMONS

## CONCEPTS FOR NEW FACILITIES

The Research Commons will be a research hub that draws together consultation services offered by the Library—a advising on research resources, scholarly communications and data curation—together with services offered by partners such as Research and Engagement, dealing with grant development, IP and grant management.

The facility will also offer technology-enabled collaborative workspace for working with and visualizing data intensive research findings, and an AccessGrid equipped meeting room for multisite collaboration.

The Research Commons in Du Bois will serve all researchers on campus, but will be a primary location for Library involvement with digital humanities initiatives and innovation in social sciences' use of information systems, complementing the Science Commons to be developed in Lederle. (See page 6.12-13.)

### Research Commons

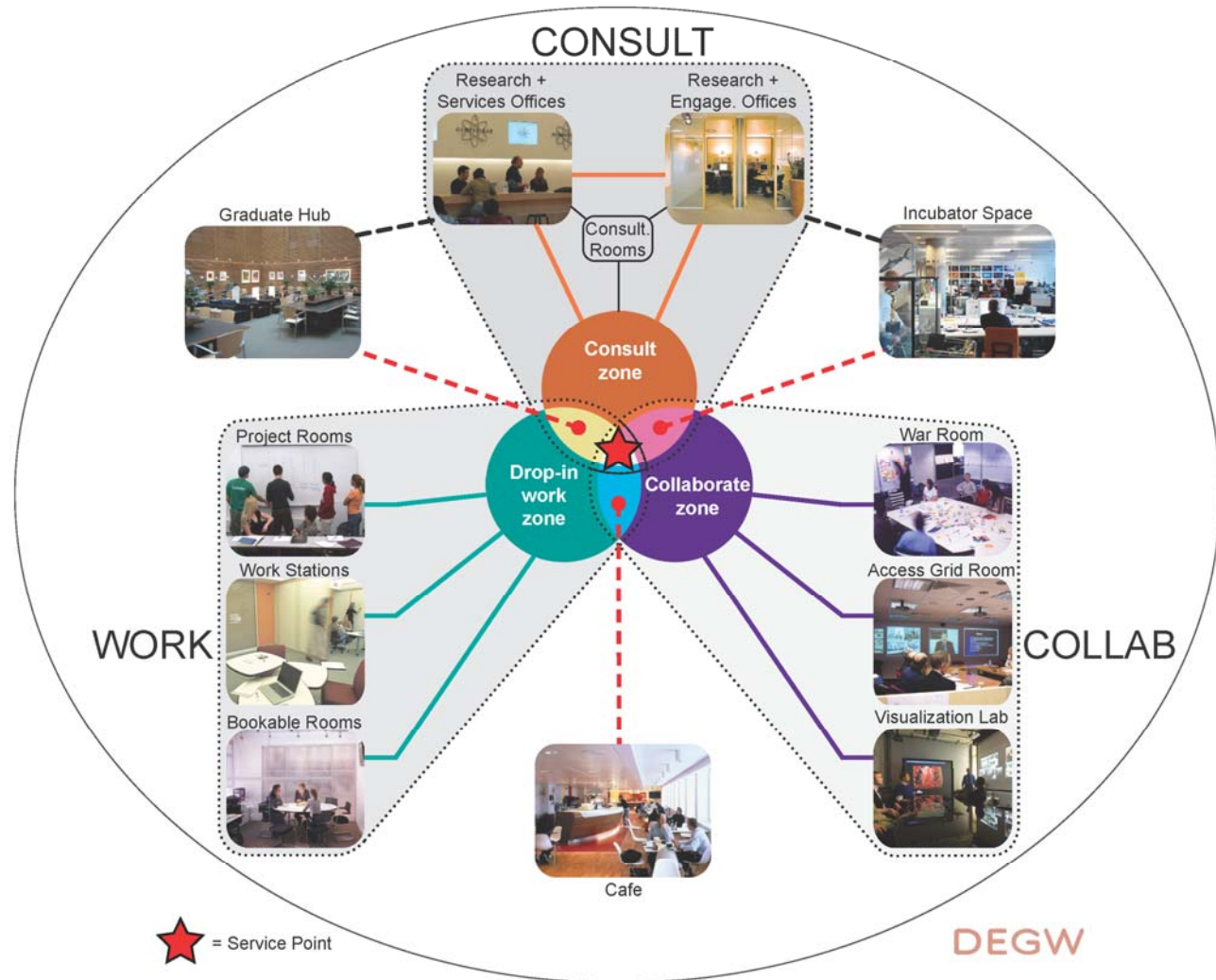



# DU BOIS BUILDING PLANNING PRINCIPLES

*Du Bois master plan recommendations were guided by the opportunities suggested by the building form itself, as explained in Chapter 3 and 6. This diagram recaps those primary strategies.*

- Convert carrel floors as a first target for repurposing underutilized space (4, 7, 10, 13, 16, 19, 22, 25)
- Relocate some of the print collections to consolidate the stack zones.
- Exploit the lowest levels for heavy trafficked showcase functions by removing the odd Floor 3 which was not in the original building design, to create a high ceiling space
- Demolish a portion of one typical double stack block to create a special destination—the Research Commons
- Develop the top floor as a shared facility for scholarly symposiums hosted by the Library on new forms of scholarship and research engagement
- Consider future expansion at the lower levels

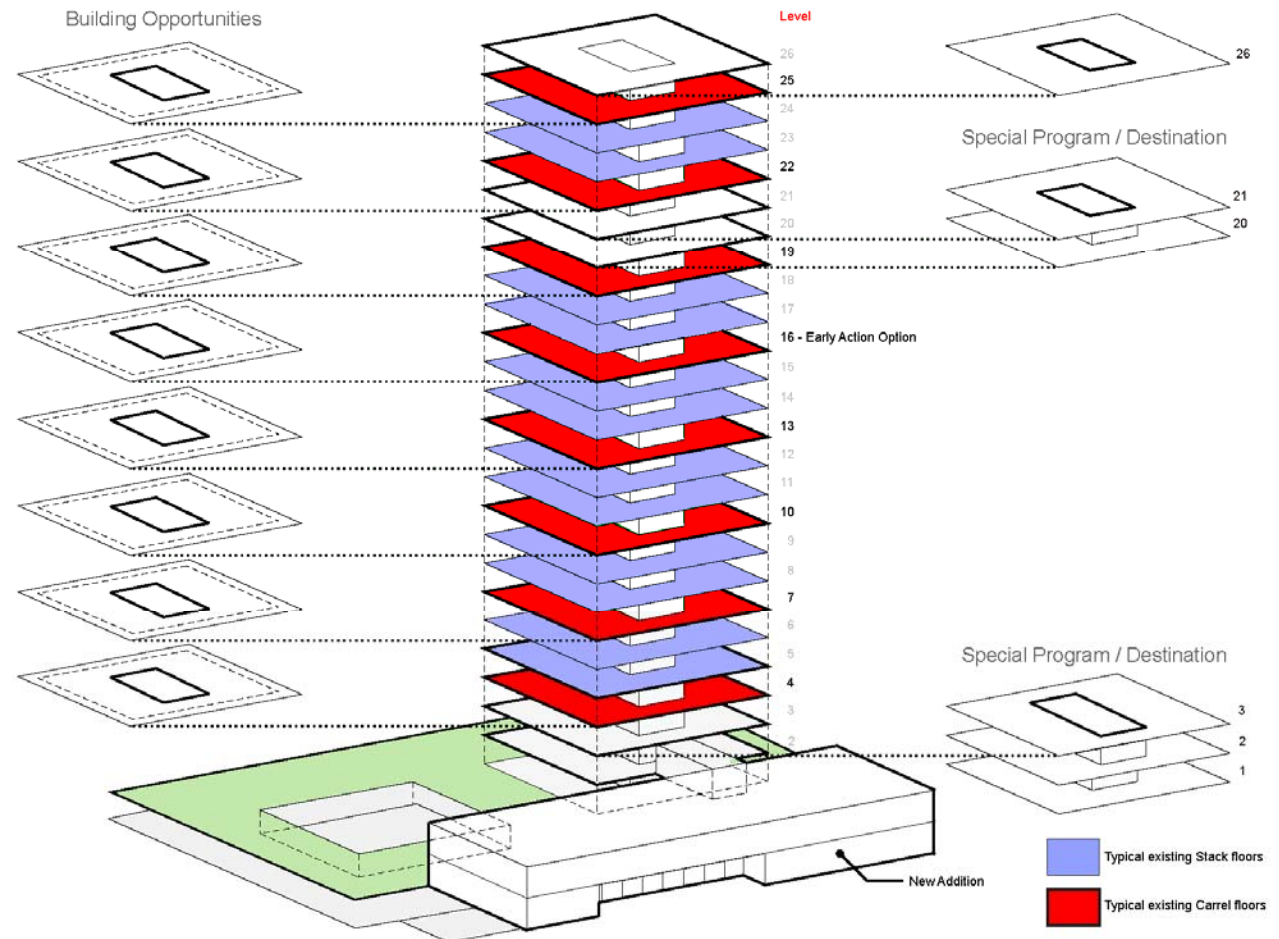

# ALTERNATIVES FOR TOWER FLOOR RENOVATIONS

## TYPICAL DU BOIS OPTIONS

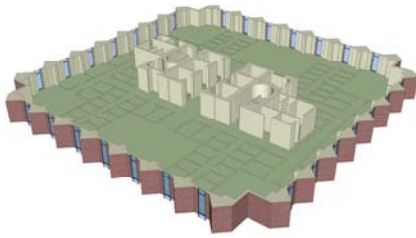

### **Conversion of Typical Carrel Floor:**

Remove interior partitioning and fit out for a variety of functions. Best option for adequate ceiling height for air distribution to enclosed workspaces. Master Plan proposes converting these underutilized floors.

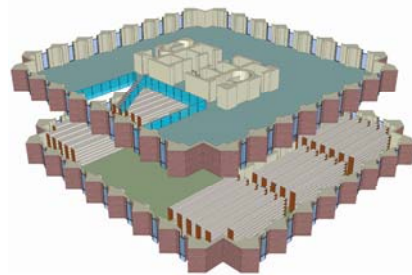

### **Convert Top Floor of Typical Stack Pair:**

Remove upper stacks to fit out for open seating, but ceiling height is very limited (and old stacks below continue to be the structural support). Because this option does not re-purpose much of the lower floor which remains as stacks, it has a relatively low cost on a per square foot basis. An opening in floor can create a double height special room.

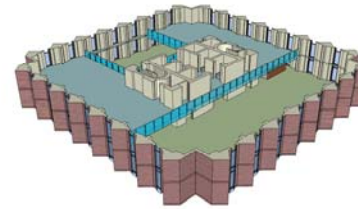

### **Remove a Stack Floor and Restructure a New Steel Supported Floor:**

Useful for new functions that require high ceilings for sight-lines, such as proposed for 20/21<sup>st</sup> floors to create Research Commons with proper infrastructure for 21<sup>st</sup> floor slab. This option creates more large open high areas but lowers the total available usable area by 25% on the two floors.

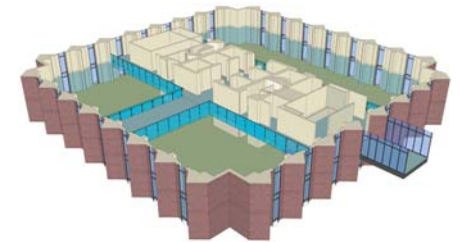

### **Remove Portions of an Existing Steel Supported Floor:**

The existing 3<sup>rd</sup> and 6<sup>th</sup> floors are supported with steel. This would make it relatively easy to take out the floor and create double height spaces. This has been proposed for the third and fourth floors to become the media hub and learning studio. This option only has to remove sections of the floor and not rebuild them.

# ENABLING PROJECTS

## OPTIONS FOR COLLECTIONS STORAGE

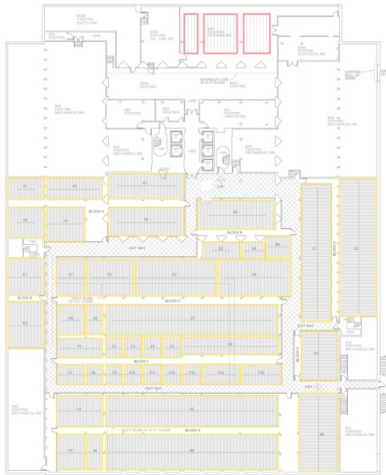

### **Renovate Du Bois Basement - Compact Shelving:**

Conversion of former storage space into compact shelving, enabled by some relocation of utility lines and upgraded environmental control systems. Partitioning at new corridors will allow incremental renovations as needed. Advantage of direct elevator access.

Est'd cost: **\$14.2 million (\$388/SF)**

Est'd capacity: 100,000 LF (5 shelves)

Area: 36,604 SF

Fitup costs (TPC): \$9.6 million

Compact shelving costs: \$4.4 million

Book relocation costs: \$215,000

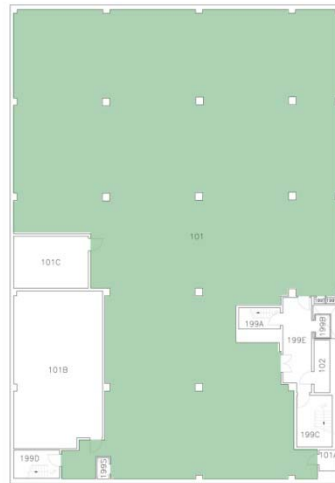

### **Renovate Goodell First Floor - Compact Shelving:**

Installation of compact shelving at on-grade structure. (Can also retain existing shelving on Second Floor currently used by Univ. Archives.) Advantage of existing loading dock for materials handling.

Est'd cost: **\$3.1 million (\$317/SF)**

Est'd capacity: 40,000 LF (5 shelves)

Area: 9865 SF

Fitup costs (TPC): \$1.4 million

Compact shelving costs: \$1.7 million

Book relocation costs: \$83,000



### **Construction of Underground Storage Facility between Du Bois and Goodell Buildings - Compact Shelving:**

Could be concealed with landscaping above and designed for reader access if desirable. Advantage of connection to both buildings.

Est'd cost: **\$35.0 mil (\$499/SF)**

Est'd capacity: 196,000 LF (7 shelves)

Area: 35,000 SF

Fitup costs (TPC): \$29.0 million

Compact shelving costs: \$6.9 million

Book relocation costs: \$357,000



### **Expansion of Existing Five College Depository - High Density Storage:**

Currently under study. Desirable solution but involves unknowns: requires negotiation among Five College Consortium and may encounter difficulties with expansion of hardened structure originally constructed for SAC. Originally designed for 500,000 vol. of which 250,000 vol. was UMA share; currently at 80% capacity.

Est'd Cost: **TBD**, estimated by FCC study at \$7-8 million for one module with capacity of 2 million volumes.

# DU BOIS PROPOSED MASTER PLAN

- *Minimize major renovation by retaining existing stack floors where possible*
- *Locate heavy traffic spaces low in the building*
- *Repurpose inefficiently used carrel floors*
- *Remove awkward infill structure at 3<sup>rd</sup> floor to create a Learning Studio on 2 with high ceiling space*
- *Create Research Commons with a special space as focus to bring people together*
- *Consolidate and enlarge Special Collections to adequately accommodate and showcase the collections*
- *Create additional centrally scheduled classroom space in the Learning Commons*
- *Increase the number of user seats to serve population growth, especially collaborative settings*
- *Enhance the top floor as a shared campus destination that aligns with the Library's mission*

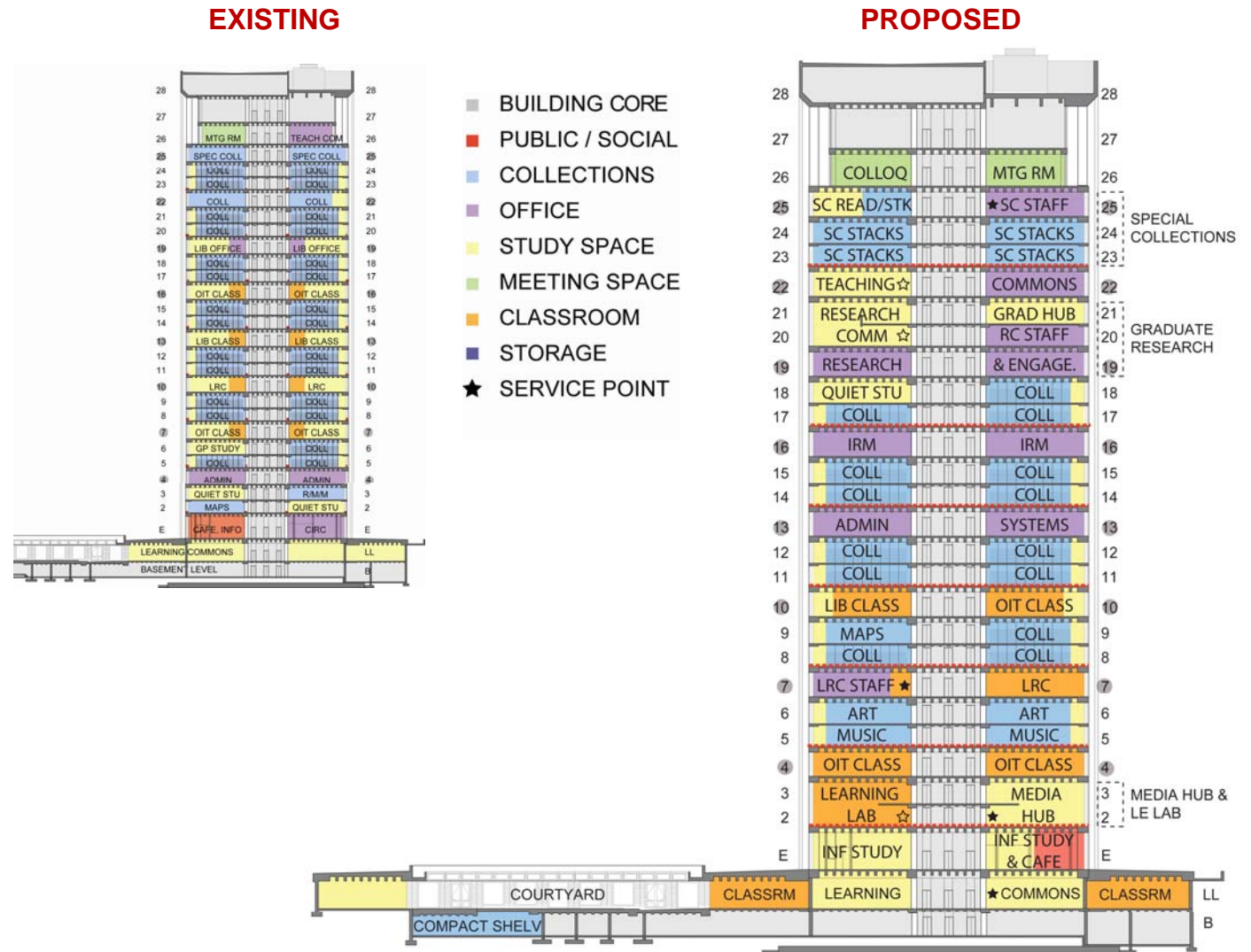



# PROPOSED DISTRIBUTION OF FUNCTIONS & SEATS

This diagram summarizes the capacities of the primary distributed program components and where they are located in the building:

- informal study seats
- classroom seats
- meeting room seats, and
- workspace seats.

The most trafficked areas are proposed for the lowest levels, the Lower Level and the 2<sup>nd</sup> floor. Similarly other classrooms for LRC, OIT and Library are kept on lower levels.

Functions proposed for the middle floors of the tower have low to moderate traffic, and are less susceptible to spikes in traffic load. Although the top floor has large capacity meeting rooms, they will tend to be used episodically and have low traffic in between, even if used as quiet study space when not booked for meetings. (See section 7 for further details.)

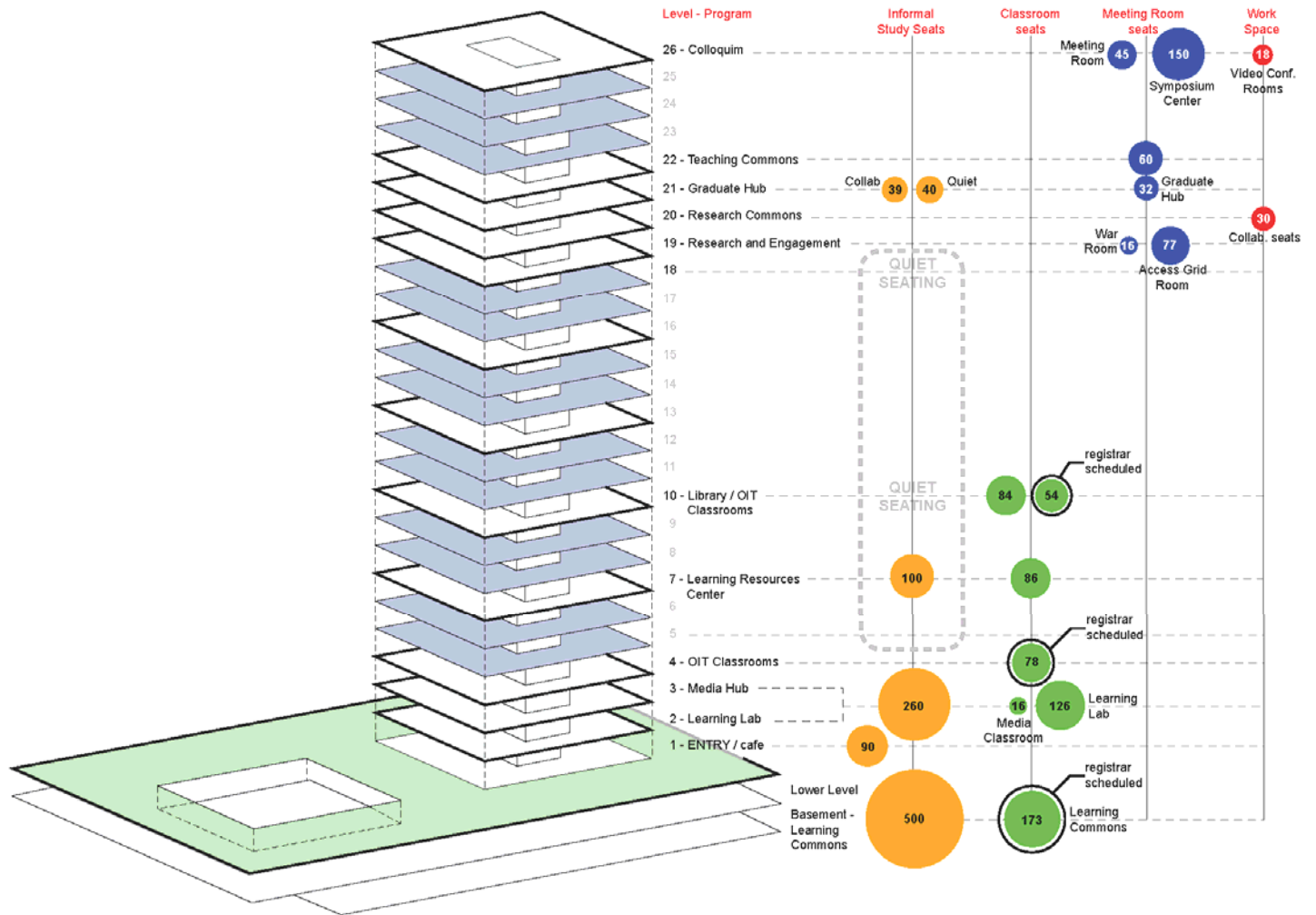

# COST SUMMARY FOR ALTERNATIVES

## Du Bois Tower Systems

The following is a summary of costs of deferred maintenance and code upgrades for Du Bois tower, presented without escalation as total project costs (TPC):

Upgrade Building Electrical System	\$8,400,000
General Lighting Up-Grades	\$2,700,000
Chilled Water Piping Replacement	\$4,500,000
HVAC and Controls Up-grades	\$15,000,000
Plumbing and Storm Water Drainage	\$5,300,000
Façade Repair Study only	(not available)
Fire Stair Pressurization Equipment	\$1,000,000
Fire Sprinkler System Installation	<u>\$4,000,000</u>
Total	\$40,900,000

## Alternative Scenarios

The following costs summarize the relative costs of various types of improvements or recommendations in the Du Bois tower (first number is total project cost (TPC) and second number is cost per square foot).

Renovation of a Carrel Floor	\$3.2M - \$310/sf
Renovation of a Stack Floor Pair	\$3.4M - \$162/sf
Stack Floor Replaced with New Floor	\$5.4M - \$346/sf
Renovate Exist Steel Supported Floor	\$3.4M - \$261/sf

The following summarizes the costs for book storage options (first number is total project cost (TPC) and second number is the cost per linear foot of shelving).

Renovate Du Bois Basement	\$14.2M - \$142/LF
Renovate Goodell First Floor	\$3.1M - \$77/LF
Underground Storage Facility	\$35.0M - \$178/LF
Expand Five College Depository	\$8.0 M - \$40/LF

# PROPOSED PHASING

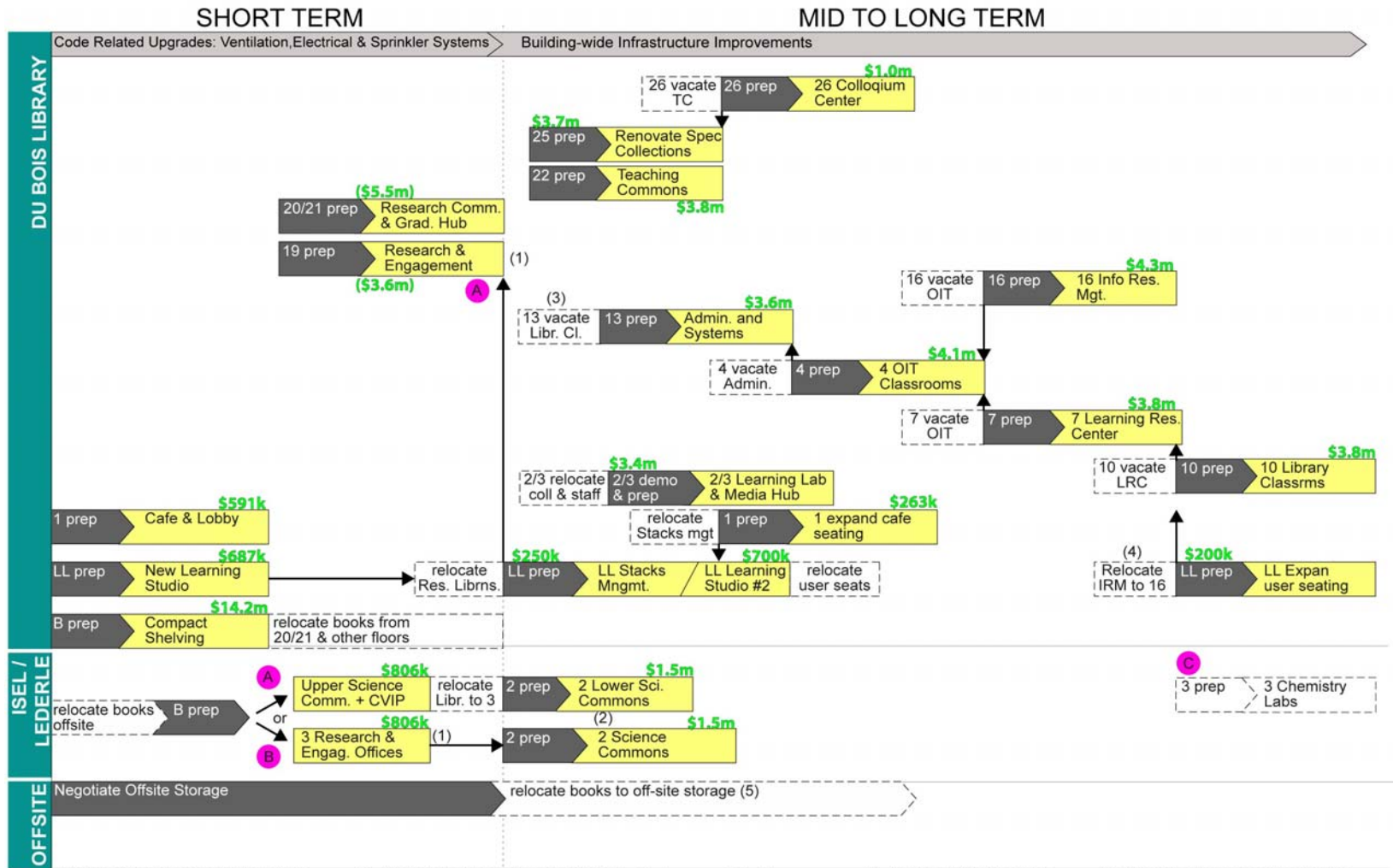

(1) - Research and Engagement is shown in two alternative locations: (Du Bois 19 or Lederle 3). In short term phase because of urgency as institutional priority. Research Commons on 20/21 also shown in short term because it is high on both R&E and Library priorities and replaces quiet seating lost with carrel demolition; becomes symbol of progress.

(2) - In Lederle, renovation and creation of Science Commons becomes more drawn out when librarians need to continue to operate out of the space. (By comparison, if the 3rd floor becomes CVIP plus commons seating, then library operations could move up there temporarily while the 2nd floor gets renovated.)

(3) - Assumes existing library classrooms can be demo-ed once new learning studios on LL are fitted out, if those can be used for library classes temporarily. Science Commons by that point can also provide a replacement library classroom.

(4) - Relocation of IRM is late in the sequence because they have only recently been moved and there is the possibility they might end up elsewhere, perhaps Goodell or off campus if the Five College Consortium merges their technical services groups in the future.

(5) - The proposed scheme assumes installing compact shelving in Du Bois basement rather than Goodell basement because of efficiency of direct elevator access. If the negotiations for the expansion of the Five College Depository do not conclude in sufficient time, Goodell basement becomes a midterm phase fall back.

# NOTES ON OPTIONS FOR SHORT TERM ACTION

A number of options have been raised, so the following are aspects to keep in mind as these options are deliberated.

**19TH FLOOR OF DU BOIS TOWER:** The most likely short term opportunity for repurposing in Du Bois is the 19th floor. It is currently mostly carrels with only a few offices for librarians, which could be relocated on a lower floor.

- **Option for Research and Engagement Offices:** There is pressure to find space for Research and Engagement, which is a group that is very compatible with the Library's mission, as both are supporting advanced research. They will be important partners in creating a vibrant Research Commons.
- **R&E projected office space is estimated to fit within a typical tower floor,** but some of the requested meeting space will need to be on other floors.
- **Opportunity if R&E is located on 19th Floor to locate the Research Commons immediately above on two converted stack floors.** This would be feasible because the master plan assumed the Research Commons could have a lot of open plan user settings that could function within low headroom conditions.

**3RD FLOOR OF ISEL:** The library is currently trying to free up space for better user seating by putting some bound journals in storage. If more book storage is made available and adequate user seating relocated, it may be possible to repurpose the top floor of the ISEL.

- **Option to Repurpose as Science Commons:** This option recommended by the master plan would develop ISEL into a two level Science & Engineering Commons, with consultative services (including R&E's CVIP), collaborative work areas and quiet seating for students. It will enable the library to meet user seating needs, both for students who want places to study and work together, and for faculty to collaborate with experts on data management. The physical characteristics of the bridge space lend it to open plan functions, and the 2nd floor connector can encourage convenient access to support services, so it would be desirable to exploit these assets.
- **Option to Repurpose as Research & Engagement offices suite:** Another option is to convert the entire floor into R&E offices, rather than locate them in Du Bois. However, this will severely cut back user seating, especially for quiet work, which must be replaced elsewhere. When renovated the 2nd floor will be predominantly user seating and consultative staff areas, but it cannot provide sufficient seats.



Notes on Options for Short Term Action, continued

- **Option to Repurpose 3rd floor as Chemistry Labs:** A recommendation of the Science & Engineering Facilities Plan was to convert the low rise structure of Lederle into Chemistry labs. If Chemistry is limited to one floor, it still may be possible to operate the library out of the 2nd floor with consolidated stack storage below.
- **Option for 2 Levels of Chemistry:** If Chemistry must occupy two levels, it puts the operation of ISEL at risk. Circulation access will be problematic at the 1st floor and the remaining area is insufficient for the required combination of collections, seating and staff areas. If ISEL needs to be relocated into Du Bois, it will have to displace other compatible use functions and stack areas.
- **Timing of Chemistry Changes:** The Chemistry renovations are part of a complex plan to renovate the Lederle Graduate Research Center, and projected as midterm projects. A key question is whether the space can be effectively used in the interim period until funding for the Lederle renovations can be secured.



# 2



## PROJECT BACKGROUND, GOALS & PROCESS

Project History and Background

Goals for the Study

Study Process



## 2.1 PROJECT HISTORY AND BACKGROUND

The University of Massachusetts Amherst is the flagship campus in the University of Massachusetts system and is ranked in the “Top 50 Public Research Universities”. It has an equally distinguished research library system that is a member of the Association of Research Libraries. The University and the Library serve an academic community of over 30,000 individuals, a total that includes a student enrollment of approximately 24,600 as well as 5,500 faculty and staff. The University is a member of the Five College Library Consortium including Amherst, Hampshire, Smith and Mt. Holyoke Colleges.

Forty years ago, the University developed a library system suited to the needs and challenges of the times. Today university libraries are in a period of dramatic transformation, particularly with usage of and access to collections and the application of technology to information retrieval and dissemination. The University is currently developing comprehensive plans for science, academic facilities and classrooms and is embarking upon a master plan process for the campus.

In the context of these planning initiatives, this feasibility study was to facilitate the University’s understanding of how the Library can respond to future challenges over the next decade and how the Library’s services and facilities can best contribute to the future scholarship, research and learning at UMass Amherst. This requires comprehensive and innovative plans for the delivery of library services in a way that addresses new changing and evolving trends in library services. The results of this study will be integrated with other plans in a way that allows the University to leverage all of its physical resources in support of its mission of teaching, research and outreach.

# LIBRARY BACKGROUND

## LIBRARY MISSION

The Mission of the Library is:

*“As a gateway to knowledge, the Libraries are a key partner in teaching, learning, and research at UMass Amherst and in the Commonwealth of Massachusetts. Supporting freedom of inquiry, the Libraries foster a diverse and inclusive environment in which to engage with ideas and acquire the critical skills necessary for life-long learning. By combining the latest information technology with excellent public service, the staff builds and maintains a rich information environment, facilitates access to it, and creates a hub of campus and community scholarly activity.”*

## LIBRARY COLLECTIONS

The Library system ([www.library.umass.edu](http://www.library.umass.edu)) includes the main 28-story W.E.B. Du Bois Library (including two lower levels), the Integrated Sciences and Engineering Library, the Image Collection Library and the Music Reserve Lab. It is the largest public academic research library in Massachusetts with over 3.5 million volumes. Together, the books, periodicals, government documents, maps, sound recordings, and microforms make up a collection of over 5.9 million items, with 2.5 million in microform format, and thousands of electronic resources. Over 7,000 print journal

subscriptions are distributed according to subject matter in the Du Bois Library and the Integrated Sciences and Engineering Library. In addition, the Library provides access to over 34,000 online journals and over 108,000 e-books.

## LIBRARY FACILITIES

The Library currently occupies 307,614 net assignable feet:

- 265,478 nasf in the Du Bois Library building
- 32,104 nasf in the Lederle Graduate Research Center housing the Integrated Sciences Library
- 679 nasf in the Fine Arts Center housing the Reserve Listening Lab
- 1,577 nasf in Bartlett Hall housing the Image Collection Library, and
- 481 nasf in South College for loading dock service access
- 7,295 nasf in the Goodell Building for storage of Special Collections and University Archives.

In addition, the Library has close to 250,000 vol in the Five Colleges Library Depository (FCLD), which is a high density 500,000 vol. storage facility off campus for lesser-used materials from the libraries of Amherst College, Hampshire College, Mount Holyoke College, Smith College, and UMass Amherst. It is almost full, as is the UMass share of it.

## LIBRARY BACKGROUND

It is anticipated that primary library services will remain in the existing library tower, but that changes in the management of collections and services may create capacity for other campus needs.

### **DU BOIS LIBRARY**

The W. E. B. Du Bois Library building, completed in 1972, was designed by the firm of Edward Durrell Stone and comprises 406,500 gross square feet. It is 28 stories tall, with a substantial lower level and basement. Each floor in the tower provides approximately 8,000 square feet of usable area. The University recently completed a Building Deficiency and Chapter 34 Study of the facility that documents the challenges. The building is an unsprinklered high rise structure classified as a Type 2C, unprotected construction, due to exposed structural members located on six levels which support the stack mezzanine floors above these six levels. Under the building code the present building height exceeds the allowable height limitation for 2C construction. These conditions will have a significant impact on future renovations in terms of size, scope and budget.

### **INTEGRATED SCIENCE & ENGINEERING LIBRARY**

The Lederle Graduate Research Center complex was built in 1971 and 1973 by Campbell Aldrich & Nulty and is comprised of two wings – a 17 story tower and a 3 story low-rise – of construction type 2A. The majority of the tower is occupied by science departments and laboratories while the low-rise primarily houses the Integrated Sciences Library and the Office of Information Technology. The LGRC is one of a few buildings on campus with the potential to be renovated for science laboratory use, hence the University sought to evaluate the feasibility of relocating library functions or possibly consolidating it into the W.E.B. Du Bois Library building.

## 2.2 GOALS FOR THE LIBRARIES MASTER PLAN STUDY

### CAMPUS PLANNING GOALS

- **Examine existing uses of library facilities and identify underutilized spaces**
- **Determine what the appropriate size is for existing functions** based on university or best practice standards, applying the “right-sizing” evaluation approach that was used in the Academic Facilities Plan and the Science Facilities Plan
- **Understand what the future growth of the physical collections will be** and examine options for storing them
- **Evaluate options for alternative space uses**
- **Understand phasing issues and associated costs**
- **Develop a master plan that is flexible and will allow incremental opportunistic projects as funding comes available**

### LIBRARY GOALS

- **Develop a vision for revitalizing the Library facilities**
- **Seek strategies to enhance the library as a major campus learning center**
- **Convert underutilized space** into new functions to serve the library’s mission into the 21<sup>st</sup> Century, especially by examining low usage portions of the collections
- **Support advanced research and e-science with new services**
- **Engage partnerships** to achieve integrated services
- **Explore new types of library facilities** that will enhance users learning and study experiences 24/7
- **Plan solutions to enhance the libraries’ staff services** and both efficiency and effectiveness of operations

### INSTITUTIONAL GOALS

- **Examine Du Bois** and analyze how much of the print collections could be removed from the building to free up space for other functions
- **Identify opportunities to add classrooms**, particularly those in the mid-range, 50 to 80 person capacity
- **Explore how new facilities might help support movement from lecture-based to team-based learning**
- **Identify optimum uses for space located at the heart of the campus**
- **Examine the ISEL** facility and analyze what space will be needed in the future, whether it needs to remain in Lederle, and whether space could be allocated to expansion of chemistry labs
- **Consolidate Research & Engagement** offices at the center of campus



## 2.3 STUDY PROCESS

The project process was based on a series of rounds of meetings, with vision workshops and interviews in the early stages and regular meetings with the Project Leadership Group, as summarized by the chart on the following page.

### **VISIONING PROCESS**

The process began with a study of the library facilities and with observation studies to analyze usage patterns of existing space that would inform future space allocation decisions. This was then followed by visioning workshops with the university and library leadership along with faculty, library staff and students to understand institutional and library goals, coming up with a collective vision for collections, services and space. Focus groups were conducted with the Library's Senior Management Group to explore scenarios by outlining drivers that would inform the desired future direction for the libraries. DEGW also conducted interviews with the university leadership to explore other compatible uses that would align with the future mission of the library or support the future of teaching and learning at UMass. Interviews included the Provost and VC of Academic Affairs, VC of Student Affairs, VC of Research and Engagement and Dean of the Graduate School. Student workshops for undergraduate and graduate students were done to explore how the library could better support their informal and formal learning needs.

Simultaneously DEGW did a Learning Landscape analysis which studied both classroom and informal learning spaces. It defined a palette of learning space types to meet future needs at UMass. Several themed workshops were done to explore new directions in pedagogy with faculty from STEM, Social Sciences and Scientific research. This in turn informed the new types of library facilities that would enhance the learning and teaching experience.

### **SPACE NEEDS ASSESSMENT PROCESS**

Workshops with the Senior Management Group were conducted to understand current and changing roles within various library departments, along with opportunities to explore in the future. A programming questionnaire involving staff counts, roles and adjacencies were sent to all library managers. This was then followed by focus groups to clarify assumptions about library workspace needs. Research was done on existing user seat counts in the library facilities and the campus to inform the future seats that need to be accommodated based on enrollment. Work sessions on collections in DuBois, Lederle and Goodell developed projection assumptions and explored reduction strategies.

# PROCESS OVERVIEW

1	2	3	4	5	6
Work Plan Development	Assess Existing Conditions	Existing Program & Space Needs	Space Needs Analysis	Conceptual Design Alternatives	Final Report
<p><b>Project Kickoff</b></p> <p><b>Activities &amp; Participants:</b></p> <ul style="list-style-type: none"> <li>• Review work plan, schedules, and planned activities for the various phases (Project Leadership Group)</li> <li>• Library facilities tour and briefing (Library staff)</li> <li>• Background data and collection review (Library staff)</li> </ul>	<p><b>Establish Vision and Assess Needs</b></p> <p><b>Activities &amp; Participants:</b></p> <ul style="list-style-type: none"> <li>• Vision workshop (Project Leadership Group, Library SMG)</li> <li>• Bldg Opportunities workshop (Library Facilities Group)</li> <li>• Interviews (Library staff groups, Research Libraries Council)</li> <li>• Themed focus groups (Compatible Uses, Undergrad + Grad Students, Technology, Scholarship + Research, Teaching + Learning, ISEL users)</li> <li>• Observational studies (DEGW)</li> </ul>	<p><b>Explore Future Needs</b></p> <p><b>Activities &amp; Participants:</b></p> <ul style="list-style-type: none"> <li>• Interviews (University Leadership, Library Staff – Special Collections, Access Services, Collections, Information Resources Management Library Systems, Admin Services/HR, RLS,)</li> <li>• Workshops (Future of Computing Facilities, New Directions in Pedagogy, Scientific Research - Faculty)</li> </ul>	<p><b>Draft Program Strategies</b></p> <p><b>Activities &amp; Participants:</b></p> <ul style="list-style-type: none"> <li>• Scenario &amp; Program distribution analysis work session (Project Leadership Group)</li> <li>• Collections projections review, service point strategy (Library leadership)</li> <li>• Preliminary program review (Project Leadership Group and Library SMG*)</li> <li>• ISEL Workshop (Project Leadership Group, ISEL)</li> <li>• Status briefing to identify decisions and priorities (Project Leadership Group)</li> </ul>	<p><b>Alternative Strategies and Concepts</b></p> <p><b>Activities &amp; Participants:</b></p> <ul style="list-style-type: none"> <li>• Review of concepts and strategies (PLG, Library SMG)</li> <li>• Collections projections and program review (Library SMG + staff)</li> <li>• Interviews (VC of Research &amp; Engagement, OIT)</li> <li>• Workshops (Research Commons, Graduate students)</li> </ul>	<p><b>Final Master Plan Review</b></p> <p><b>Activities &amp; Participants:</b></p> <ul style="list-style-type: none"> <li>• Presentation of Recommendations (Project Leadership Group)</li> <li>• Review of final program distribution and concepts (Library SMG, staff)</li> </ul>
				<p><b>Project Update &amp; Program Review</b></p> <p><b>Activities &amp; Participants:</b></p> <p>Reviews (Library staff, Project Leadership Group)</p>	<p><b>Final Report Presentation</b></p> <p><b>Final Presentation</b> (Executive Review committee)</p>

## STUDY PROCESS, continued

### PROGRAMMING PROCESS

The team was provided with the existing space inventory, indicating library and non-library uses of the library buildings, and a library personnel listing. From this a program listing was developed that compared the existing space with a “right-sized” program and a projected program for 2020.

The space program estimates were done in net assignable square feet (nasf) which does not include any circulation. Then an internal circulation factor of 30% was added to totals to generate estimates of usable or departmental net square footage that could be used in the stacking and blocking test fits. Exact fit and space requirements will need to be determined in more detail as individual projects move forward.

The existing data changed during the course of the project as a number of projects were ongoing: library staff groups were moved around, the Government Documents area changed, the Learning Commons phase 2 was completed, and the classroom project on the lower level was given approval to proceed in the former library Function Room. These changes required reconciliation with new area allocations and changes to assumed locations.

The programming process reviewed current UMass standards and adjusted assumptions based on library planning typical practice which needed to accommodate library specific requirements, like book trucks in workstations, and to assume more efficient space standards where possible.

The space estimates were done at a master plan level of detail to inform comparison of existing with “right sized” and generate order-of-magnitude estimates to prioritize allocation of functions between the buildings. A more detailed examination of storage requirements and functional specific needs should be done to reconcile differences and confirm design requirements when projects are ready to proceed.

### SPACE STRATEGIES AND CONCEPTS

All the findings from the research and programming then led to the formulation of space strategies for potential distribution of functions and new concepts for facilities in the libraries that integrate user groups and services. Reviews were held with the Senior Management Group to review and refine these strategies and an all day charrette was held with the Project Leadership Group to explore the alternatives for space allocations in DuBois and Lederle.



# 3



## EXISTING CONDITIONS

Site and Context Issues

Existing Facilities

Constraints & Opportunities





## 3.1 SITE AND CONTEXT ISSUES

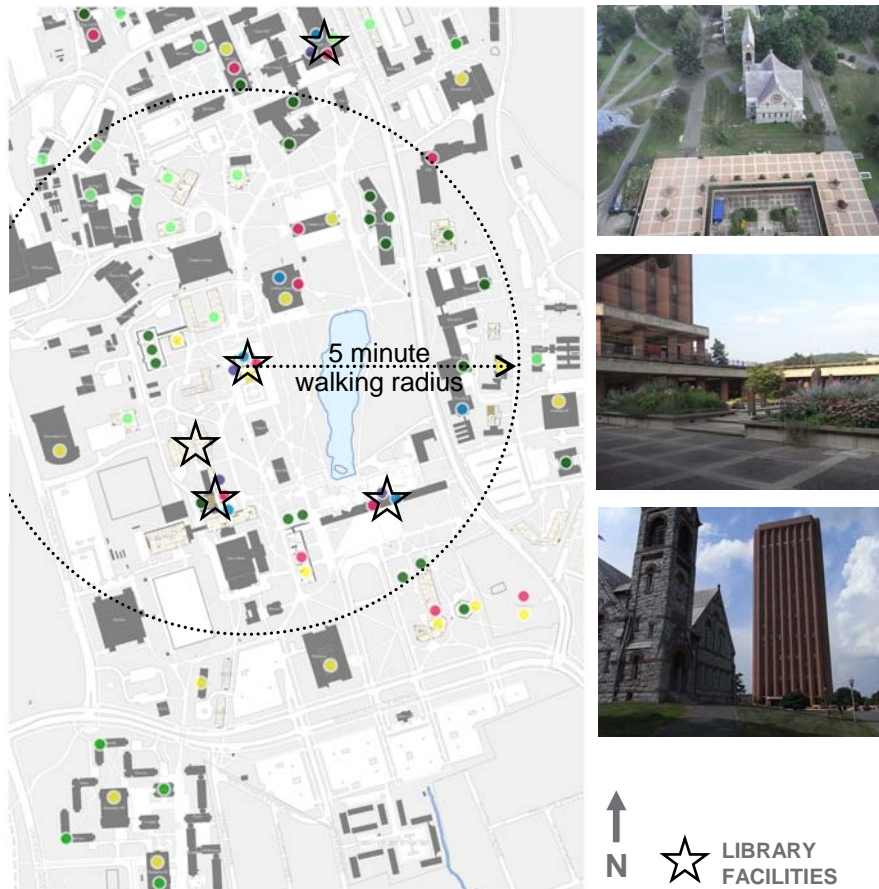

The strategic location of the Du Bois building puts the Library in the scholarly heart of the university campus and its tower there is symbolic of the academic mission of the University. Key issues of site context include:

- The central location of the Library allows ready accessibility to students at a major crossroad of student traffic, being close to the center of the Humanities and Social Sciences precinct as well as the cluster of student life facilities at the center of the campus. Undoubtedly this central location has played a part in the great success of the Learning Commons.
- Proximity to the pond provides great views from the Library and respite for those seeking a reflective place to work.
- The location of the Integrated Science and Engineering Library in the Lederle building is at the gateway to the Science and Engineering precinct on campus. It is well positioned on the bridge connecting the two primary wings.
- The Goodell building's proximity to Du Bois has the potential for expansion of on-site storage and alternate loading dock access.

● FOOD  
● COMPUTING SPACES

● COLLABORATIVE WORK & INFORMAL LEARNING  
● GENERAL USE/RESIDENTIAL TEACHING SPACE

● LIBRARY  
● AUDITORIUM TEACHING SPACE

## 3.2 EXISTING LIBRARY FACILITIES

Generally, in recent history, library facilities on the UMass Amherst campus have tended towards consolidation and centralization.

Originally facilities were separated in several locations including Goodell (the Undergraduate Library), Morrill (the Science Library), Lederle (the Engineering Library), Bartlett Hall (the Arts Library and Image Collection) and Du Bois (the Graduate Research Library). As the University grew, the Goodell facility became inadequate to accommodate the growing general library requirements and these functions moved to Du Bois. In a further centralization effort the Morrill facility was closed and these functions were moved to Lederle which became the Integrated Science and Engineering Library (ISEL).

Currently the **Du Bois facility, at 436,000 GSF, has become the dominant central library facility** for the University. Housing the library administration, the greater part of the volume collections, the undergraduate and graduate library services and the majority of the public quiet and collaborative study area. Its large size, central campus location and strong physical image strongly recommend that it remain in library use today.

Du Bois was originally designed and built under a special building code provision for State libraries. This has created a series of problems in adapting it for new and complementary uses because it trips a requirement that the building be brought up to current code compliance.

At this time the remaining areas of satellite functions include:

- **Integrated Sciences Library (ISEL)** – Engineering texts, quiet study and research serving North Campus students (32,104 SF).
- **Bartlett Hall** – Location of the Campus Image Collection and related media services chiefly serving the History and Humanities Departments (1,577 SF).
- **Goodell** – Basement book storage of approximately 8,000 LF of shelving (7,295 SF).
- **The Fine Arts Center** – The current location of the music reserve lab.
- **Five Colleges Library Depository (FCLD, aka “The Bunker”)** accommodating approximately 500,000 volumes of which 250,000 is allocated to UMass Amherst.

## 3.2 EXISTING LIBRARY FACILITIES

Lederle Graduate Research Center



DuBois Library



Goodell Building



Bartlett



Five Colleges Library Depository (FCLD)

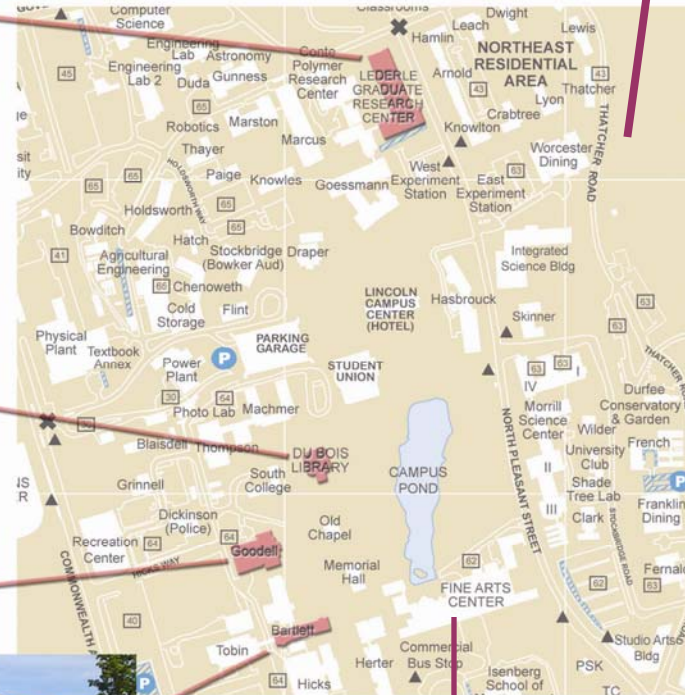



## 3.2 DU BOIS LIBRARY EXISTING FACILITIES BACKGROUND

The **Du Bois Library** is fraught with functional and physical issues. Being central to the function of library operations, it will be the major focus of this section.

Du Bois Library is organized so that the main level under the plaza provides a large open Learning Commons for undergraduate study, which is supported by a main Access Services desk, a reference desk and various learning service desks providing assistance to students and graduate students alike in a newly renovated space looking out onto the lower level courtyard.

The tower areas support other functions that include Library Administration & Systems, Special Collections, training and classroom space, study areas and enclosed carrels.

Existing service points are indicated on the diagram on page 3.10 labeled “Existing Service Points.” Most of the library is accessible to patrons but there are some areas controlled by staff.



*Learning Commons Study Area*

## 3.2 DU BOIS LIBRARY EXISTING FACILITIES BACKGROUND

While there is a small amount of book storage in the library basement, most of the book storage occurs on the stack levels indicated on the accompanying drawings. Each stack floor supports along the exterior of the building adjacent to the window openings 64 open study carrel spaces.

Generally closed carrel study spaces are located on the floors between pairs of stack floors.



*Typical Stack Level*



*View of Learning Commons Level*



*Low Ceiling Height Open Study Area*

At the lower levels of the library four levels were constructed with steel support beams in the place of the originally designed book stacks. These levels are characterized by low ceiling heights and open study configurations.

## 3.2 DU BOIS LIBRARY EXISTING USES ON CLOSED CARREL LEVELS

Typical carrel study levels have large rooms in the center of the North and South faces. The corner are used for various functions. Carrel spaces run along the North and South, whereas offices are located along the East and West.

- Level 22 East Asian Reference Collection & H.M. Bond Center**  
Large reading room on North with group study room in NE  
H.M. Bond Center on South face
- Level 19 Collection Development Office, ILL Office**  
Collections Dev., ILL & Doc Delivery (being relocated)
- Level 16 OIT Comp Classrooms & Faculty Writing Place**  
OIT computer classroom on North face  
Library Instruction Room (reservable) on South face  
Scholarly Communications Office in SW corner
- Level 13 Davis Collection**  
LRC Classroom on N and S faces
- Level 10 Learning Resource Center**  
LRC Classroom on N and S with offices on all four corners
- Level 7 OIT Computer Classrooms**  
OIT PC classroom on N; MAC classroom on S & SW  
Instructor Office on NW corner. Group study on SE

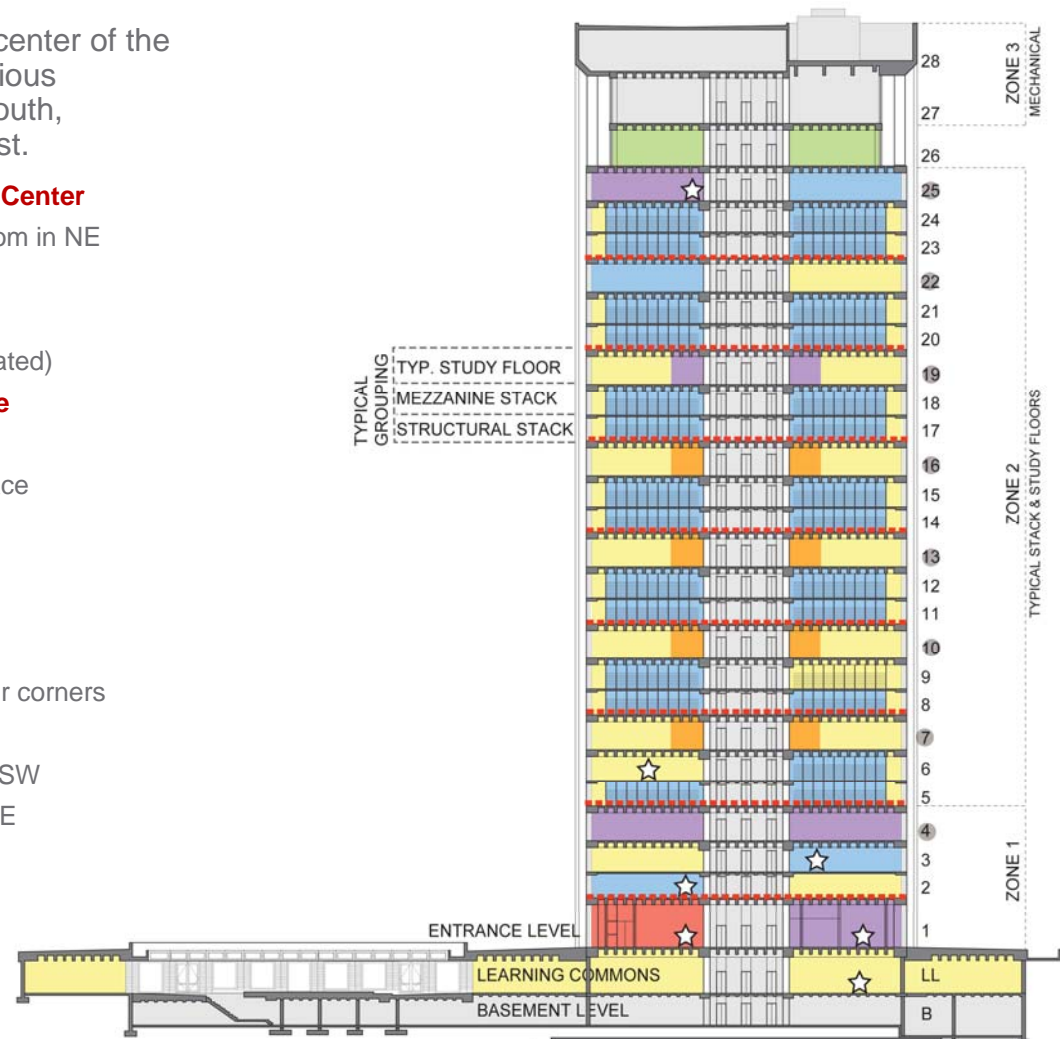



## 3.2 DU BOIS LIBRARY EXISTING USES ON TYPICAL STACK LEVELS

All typical stack levels have quiet study carrels along the perimeter

### Level 24 Typical Stack Level

Large monograph storage in NE corner

### Level 21 East Asian Collection, Near Eastern Collection

### Level 20 Dissertations & Theses

### Level 11 Juvenile Collection

### Level 9 Art & Photography

Part of the floor is a large open, quiet study area  
Artifact display and storage

### Typical Stack Levels

8, 12, 14, 15, 17, 18, 23

### Level 5 Law Collection, Periodicals

Memorial stair leading to Entry level  
Steel staircase in SE corner

### Level 4 Library Administrative Offices

Business Office on South face  
Development Office on West face  
Systems on North face with server room in NE

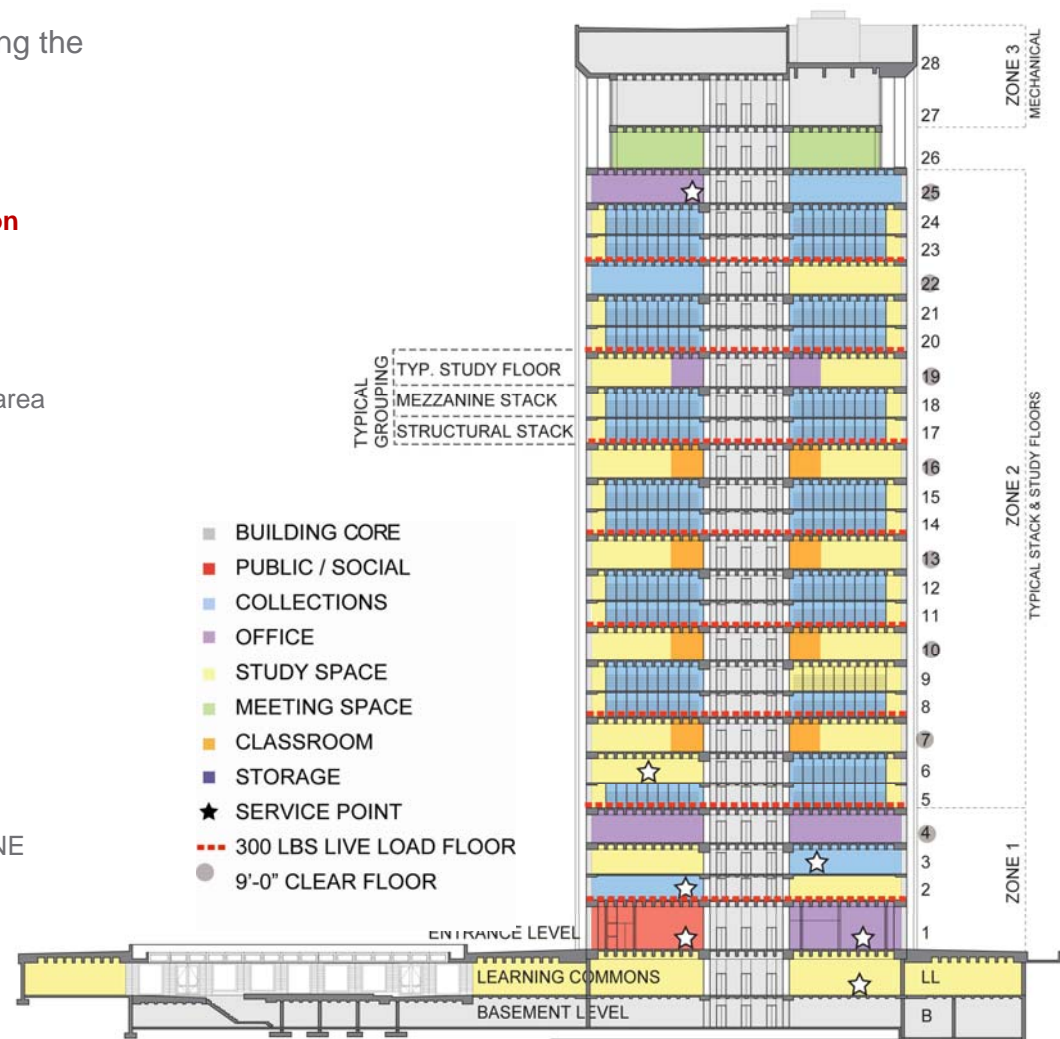

## 3.2 DU BOIS LIBRARY EXISTING SERVICE POINTS

There are currently service points on six levels.

### Level 25 Special Collections

Reading room on North side, storage at NE corner  
DuBois Room

### Level 6 Gov Doc, Patents, and Trademarks

Offices, open study space and group study

### Level 3 Reserves & Media

Microform equipment on W face adjacent to core  
Reserves staff and stacks on N face  
Media viewing for users on NE corner  
Quiet study space on South face

### Level 2 Map Collection

Map collection on South face  
Quiet study space on North face

### Level LL Learning Commons

Integrated service desk

### Level 26 Teaching Commons

Proposed Teaching Commons in North face  
Large meeting space in the South face

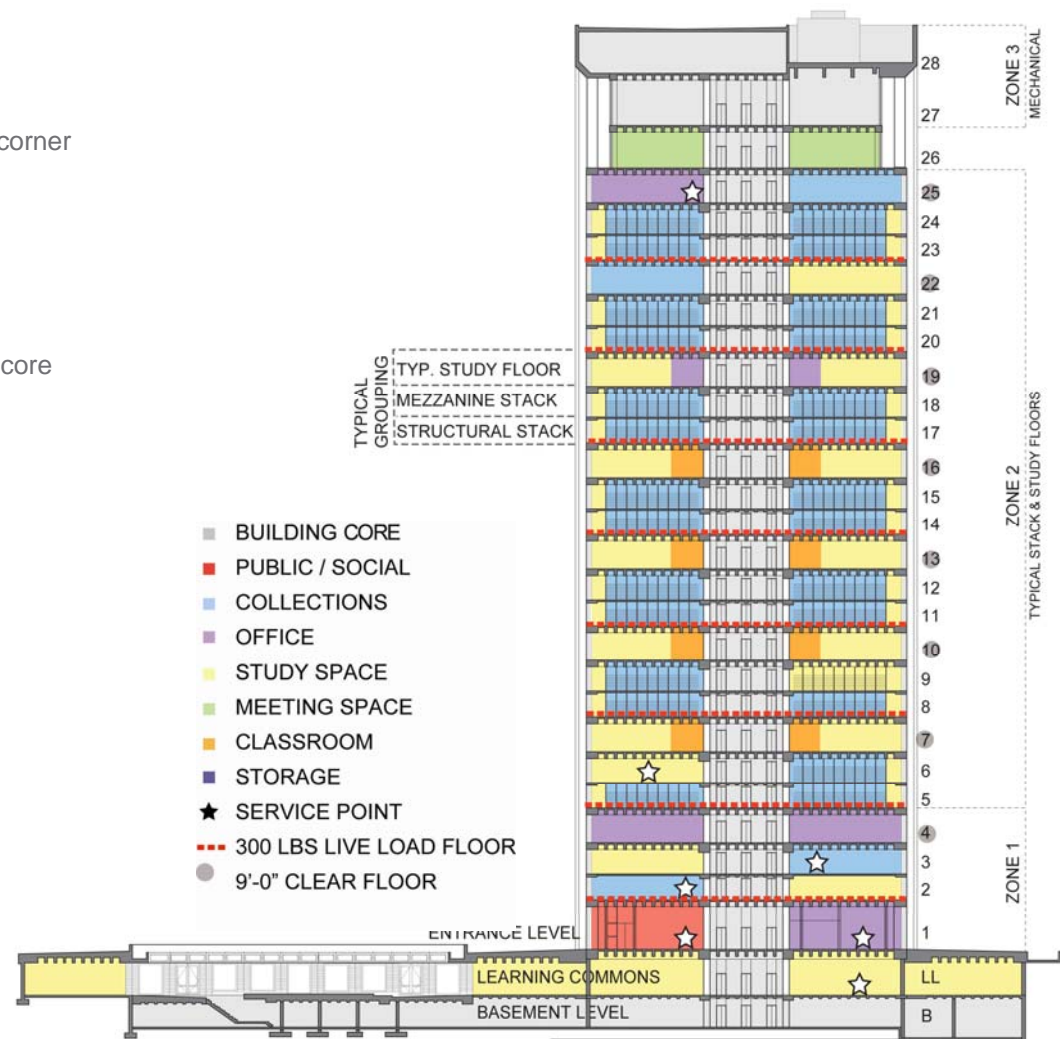

## 3.2 DU BOIS BUILDING PHYSICAL DESCRIPTION

The Du Bois structure was built in 1973 as a research library, designed by the architect Edward Durell Stone. It was considered to be a “cutting edge” design at the time, which focused on the research function it was intended to accommodate. The 26 story tower is designed to have small 11,100 GSF floor plates stacked in such a way that **each floor that was intended for studying was sandwiched between two book stack floors**. This allowed a researcher to find accommodation in a carrel on a study floor and have the relevant volumes shelved within a floor’s distance from his/her workspace. The entire building was served with a bank of elevators allowing quick access to the floor of choice. Additionally, **toilet facilities were only located on the study carrel floors** with the understanding this would be the only floor with long term occupancies.

**The architect’s strong focus on this design that specifically accommodated research has made the building a very difficult one to re-purpose for general library functions.** The study carrel floors are the only floors in the tower that have enough vertical dimension (9’-0”) for accommodating new occupancies. Since they only have a net space of 8,900 SF useable area (excluding core functions) and are separated by two floors of book shelving, the usefulness of this space is severely limited. Additionally, the expense of and past resistance to the physical removal of the carrels has created limited areas that were available for reuse.

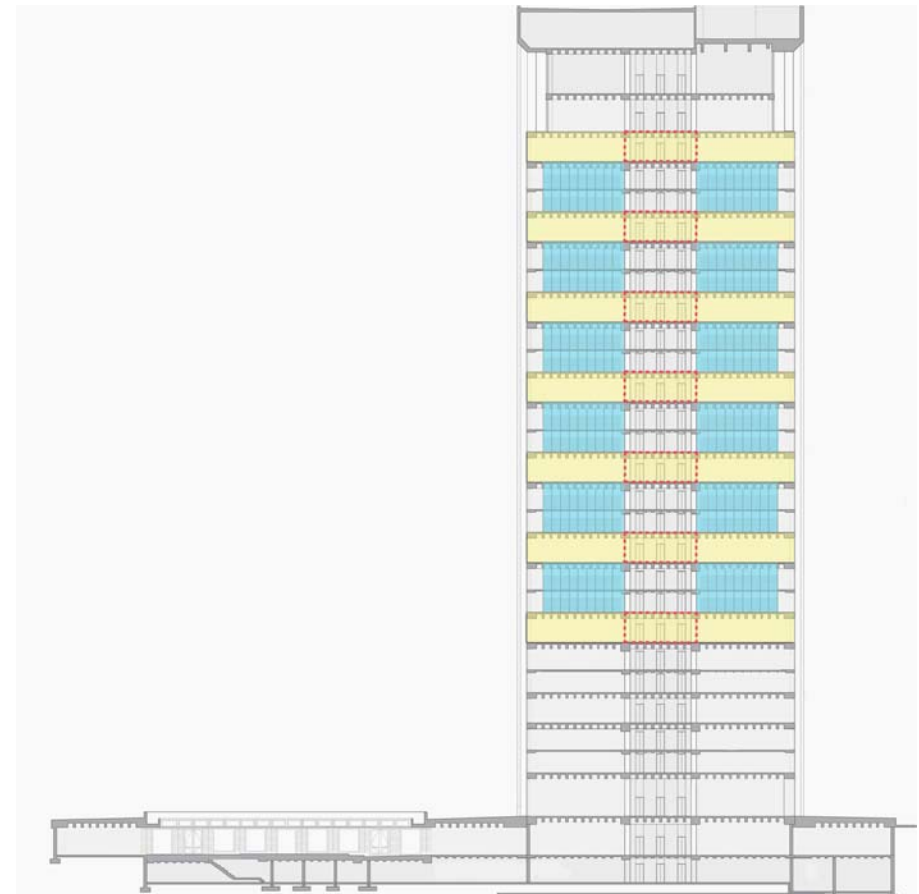

Study Carrel Floors  
Book Stack Floors  
Restroom Facilities





## 3.2 GOODELL STORAGE FACILITY EXISTING FACILITIES BACKGROUND

The existing library facilities are in various states of repair and suitability for their current uses. While **Goodell** was originally built as a library, the age of the structure, the relatively small spaces and the difficulty of renovation have prevented it from continued use for library functions. It is currently largely used for campus administrative functions and some library book storage.

The building is composed of the original 3 level library structure facing the main campus area and a later 6 level addition located behind that steps down the hill behind. The three upper levels of the addition match the levels of the original building. All of the levels have limited floor to floor height which makes renovation of the structure difficult and costly.



*Goodell Main Entrance*



*Goodell Basement Storage*

The current area devoted to library use is on the second level of the newer addition. It is composed of standard book storage shelving and totals 7,250 SF

## 3.2 BARTLETT IMAGE COLLECTION EXISTING FACILITIES BACKGROUND

**Bartlett** is a classroom building occupied by the Fine Arts that provides space for the library's Image Collection at a location that is convenient for students in the Art History and Humanities, whose departments are located in the same building.



*Image Collection Area*

*Bartlett Main Entrance*



## 3.2 INTEGRATED SCIENCE & ENGINEERING LIBRARY EXISTING FACILITIES BACKGROUND

The low rise structure of the Lederle complex is a building that works well for the library functions that it accommodates, especially the bridge part between the low rise and high rise buildings. The size of the bay spacing, the simple concrete structure, the ample clear height of the ceilings, the relatively large floor plates and large areas of glazing on two sides make it a comfortable library space with interior areas suited for both reader study space and stacks. With the proposed renovation of the Lederle complex, there is pressure to bring Chemistry lower in the building and repurpose the library space into chemistry labs.



*Study and Research Area*



*Reference Collection Area*



### 3.3

## EXISTING BUILDING CONSTRAINTS DU BOIS AGING BUILDING SYSTEMS

**Elevators:** The building is served by five existing elevators. At the time of construction a sixth elevator was planned for but not installed. The elevators are configured so that one bank serves the upper floors and one bank serves the lower floors with a transfer opportunity at the 14th floor. **Currently the elevators are undergoing a two year renovation process that will open up all five existing elevators to all floors and recondition the existing cabs and motors.** This should improve the current long waiting times for users and frequent shutdowns for maintenance.

**HVAC Systems:** **Except for the main level and isolated areas in the tower, the building is not air conditioned.** The fresh air needs of the tower are served by supply air ducts that are located in the exterior columns of the building and returned via ductwork at the core of the building. Supplemental heating is provided at the exterior face of the building under the windows using hydronic baseboard units that are connected to piping in the exterior columns. This system is very old and leaky and currently is creating a maintenance nightmare. **The current system is not ideal for the long term storage of books.**

**Electrical Systems:** The electrical system in the tower has not been significantly changed since its construction. For many current uses the system simply is not adequate. There are currently plans and funding in place to correct these problems.

**Building Exterior:** The building is clad in common brick. Originally, it is reported, that the building was to be clad in stone. It is believed that the switch to brick with out proper changes to the support and detailing of the water shedding systems have caused the brick to crack and chunks of the brick exterior to fall to the plaza, endangering passers-by. Although there are funds set aside this condition has never been fully corrected despite multiple efforts. The temporary solution has been to keep pedestrians away from the building.

**Hazardous Materials:** Current renovations have uncovered the existence of PCB's in the sealants used in the original construction. These materials must be removed and disposed of according to current regulations. Any future renovation work should be prepared to encounter this and other hazardous materials that may have been used in the original construction.

### 3.3

## EXISTING BUILDING CONSTRAINTS DU BOIS CODE COMPLIANCE CHALLENGES

**Sprinklers:** Except for the Main Level, the building is not currently provided with sprinklers. This was allowed by the codes at the time the building was constructed but is a major code violation at the current time. **Suffice it to be said that any future renovation of even a minor nature would trip the requirement for sprinklers to be added.**

**Toilet Rooms:** The existing toilet facilities occur typically only on the carrel floors. **These toilets are not handicapped accessible**, except in some cases where they have been converted. If future renovations are undertaken these rooms will need to be expanded and reconfigured.

**Elevator Lobbies:** Because the building is not sprinklered the elevator lobbies at each floor need to be separated by a **one hour rated set of doors** from the remainder of the floor. These changes are currently being done under a summer construction program.

**Smoke Proof Tower:** Current codes require that an egress stair for a high rise tower be provided with a system to prevent smoke laden air from entering the egress stair. **There are current plans that are being prepared to correct this problem but have not yet been implemented.**

**Emergency Electrical System:** Recent code requirements mandate that a separate emergency electrical system be provided that does not currently exist in the building. **Plans to make these changes currently are being prepared but have not been implemented.** They will be required if any significant construction projects are initiated in the tower.

**Egress and Interior Communication Stairs:** The construction of the stairs in the tower portion of the building was done in such a way that many of the current dimensional requirements for stairs are not met. For the most part this can be corrected by changes to railings and other minor changes. However in the **egress stairs the intermediate landings do not currently have enough depth to meet code.** Because the stair is constructed in poured concrete this will be very difficult to correct.

### 3.3 EXISTING BUILDING CONSTRAINTS

#### DU BOIS – MECHANICAL, PLUMBING AND STRUCTURAL ISSUES

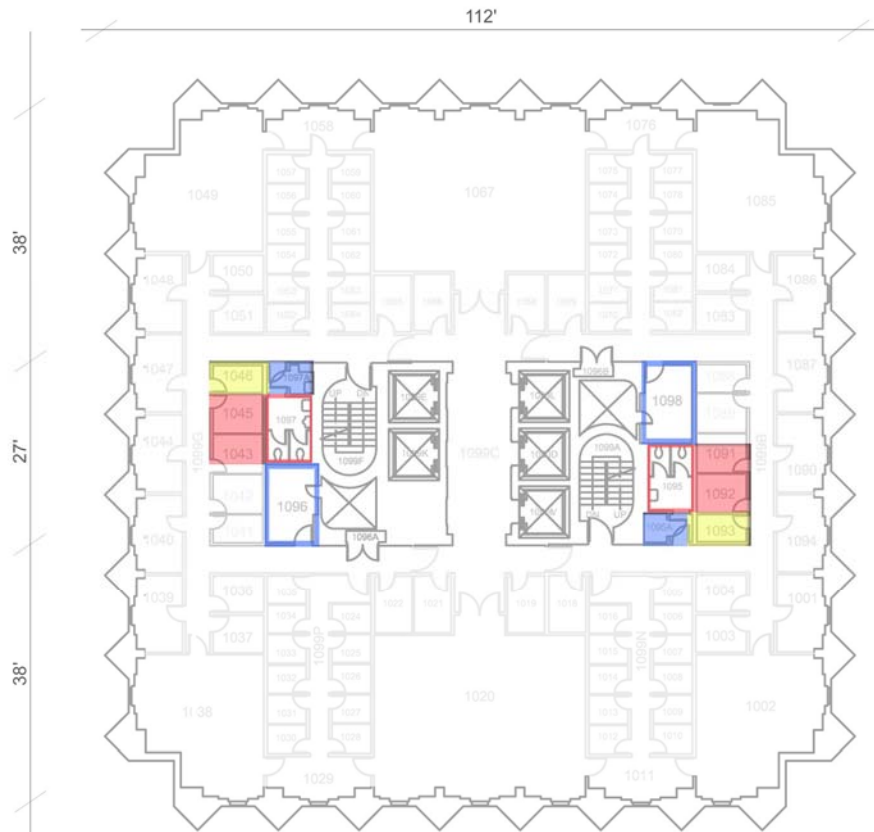

- Existing Toilets
- Toilet Expansion
- New Electrical Closet
- Mechanical Expansion
- Existing Mechanical

Total Gross Area:	11,173 sf	
Total Programmable Area:	8,942 sf	(80%)
Total Exterior Walls and Core:	2,231 sf	(20%)

The relative ability to plan new uses for the typical tower floor is limited by its small size and relatively large central area that is occupied by the core. The accompanying diagram illustrates the shape and dimensions of the spaces available for reuse (on carrel floors) and the locations that the core would be increased to accommodate new plumbing, electrical and HVAC changes required to bring the building up to current codes. As the adjacent diagram shows, increasing the core laterally will allow the main portions of the floor directly connected to the elevator lobby to remain unobstructed for the distribution of program.

Structurally, post-tensioning cables crisscross the floor slab at 10'-0" intervals. **Effectively, this construction method eliminates the possibility of removing portions of these floors to connect adjacent floor spaces or insert open stairways.**

One anomaly of the current building construction is that floors 3 and 6 were not actually completed as stack floors as originally intended. Instead they were retrofitted with steel supported floors directly supported by the core and exterior columns. The construction of these floors would allow for removal of portions of the floor without much difficulty.



### 3.3

## EXISTING BUILDING CONSTRAINTS DU BOIS – CIRCULATION, IMAGE AND ACCESSIBILITY

The main central tower of the building, the element that gives it an iconic image, also gives it a characteristic that is very useful: **one central, easily recognizable and controllable access location.**

However, in other ways this tower also creates problems.

**The small floor plate that the entrance occupies becomes very crowded** with persons waiting for the elevators to go into the tower, waiting for coffee at the “Procrastination Station” or checking out books at the circulation desk. Efforts to correct this problem appear to be in the works as the check-out station is being moved, the elevators are being improved and it is planned to move the café behind the elevator area with its own seating area.

**The tower also creates a problem in way finding.**

Although graphic material is available at the information desk for finding destinations within the tower it is extremely difficult to travel from floor to floor or circulate easily in search of less specific objectives. Discussions with new students uncovered a reluctance to go into the Tower for fear of getting lost or of not knowing what to expect in the way of security or privacy.

When the building was constructed the attitude about atmosphere and security issues in libraries caused solutions that **included metal caged-off areas and very utilitarian finishes and detailing.** Some of these elements still exist and provide a most unwelcoming atmosphere in the older portions of the building. Much of this has been corrected but typically **the small floor plates, small windows and low ceiling heights have been difficult features to overcome.**

The horizontal division of the tower into small floor plates and the separation of the most reusable floors by two levels of book stacks make it difficult to be efficient in the layout of service areas. **The flow of materials through the library and the ability to collaborate between different library departments are complicated by significant distances , their locations on different floors and the time required to transverse them.**



### 3.3

## EXISTING BUILDING CONDITIONS DUBOIS – SUSTAINABILITY AND PERFORMANCE

When the building was built energy costs were not of the same importance that they are now. **The exterior of the building was not provided with any insulation.** Further impacting these issues are the fact that building supply air ductwork and heating pipes are located within these un-insulated exterior column enclosures. The correction of this problem likely lies in the re-cladding of the building with new insulated cladding. There are plans to fund a study to correct the brick failure problems and the issue of insulation should be addressed at the same time.

Exterior glass in the tower is provided in narrow strips between the exterior columns. In the original design concept reading desks were provided at the windows and this works quite well. Natural light is provided at the reading surface and a low level of light is provided where the books are stored. At the carrel floors where enclosed carrels are taking up the interior space this also makes sense.

**In the light of current proposed building program the small windows and low ceiling heights make reuse of the spaces problematic and the existing stack areas quite dark and gloomy.** Ways of opening up two story spaces to let the light stream into the interior of the building would improve both the day lighting of the space and the interior atmosphere.



### 3.4 OPPORTUNITIES FOR RENOVATION DUBOIS – BOOK STACK FLOOR RENOVATIONS

**Interestingly the removal of the supported stack floor would create some opportunities:**

First, it should be noted, the lower level of each stack floor has been constructed to allow it to support the weight of two floors of books (300 LBS/SF). This is the equivalent of the weight of compact shelving. This may not be of significant benefit on its own because by using the resulting double height floor space for compact shelving, there is no net increase in book storage.

However, if a new floor, supported on new steel framing supported by the exterior wall and the core (i.e. not using the existing floor for support) was constructed at the intermediate level, the lower floor could support compact shelving.. It should be understood that both of these new spaces would have limited ceiling heights and that compact shelving on a beam supported floor can be problematic due to structural deflection.

The removal of a supported stack floor would be a relatively simple operation to do from a construction point of view. It would create an opportunity to provide new spaces with a clear height of 18'-6" that could have functional relevance for use as traditional larger library general study spaces or media rich classrooms.

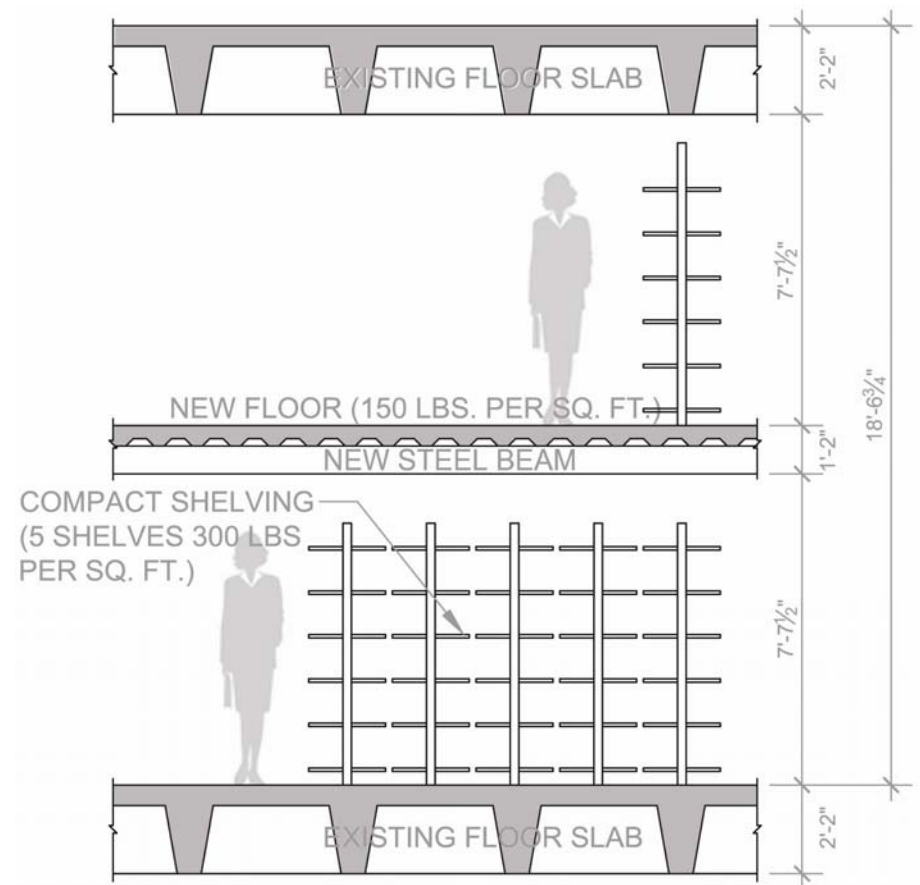

## 3.4 OPPORTUNITIES FOR RENOVATION DU BOIS – SINGLE STUDY CARREL FLOOR

### Single Study Carrel Floor Conversion

It is clear that a study carrel floor can be re-used for any type of space that can be accommodated with a total space of 9'-0" clear height between slabs (finished ceiling height of 7' 6").

The only limitations are that the total available contiguous area is limited to 7400 SF and that the area of floor plate is essentially divided in half by the requirements of the building core. There is no opportunity to connect to an adjacent floor except via the elevator or the existing fire stair because of the restrictive structural system.

Given the relatively difficult location of this space in the tower, construction costs would be relatively expensive compared with other similar places to renovate on campus.

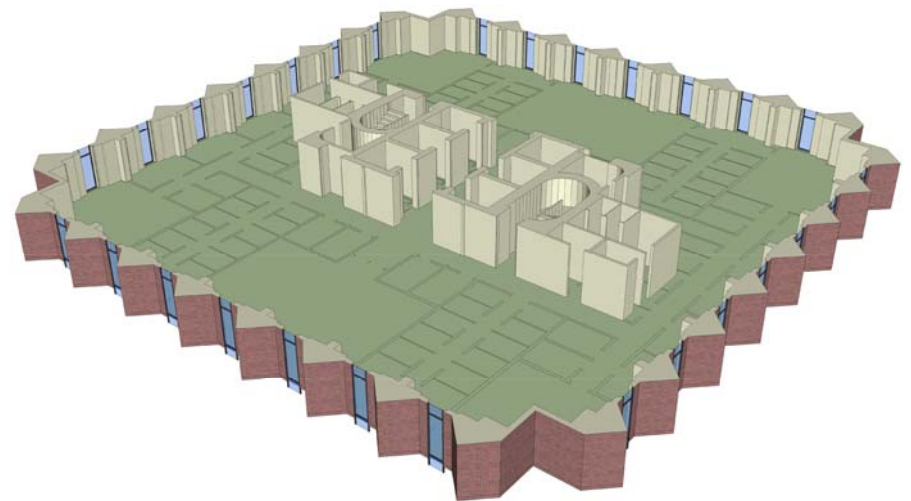

## 3.4 OPPORTUNITIES FOR RENOVATION DU BOIS – STACK FLOOR CONVERSION

### Stack Floor Conversion

Because the upper level of stack floor may be removed with relative ease it would be possible to open up a portion of a stack floor group by removing the book stacks either all or partially from the upper level and removing a portion of the lower level stack system with its supported slab. The result would be a configuration as depicted by the accompanying diagram. The **double height portion of the space would be suitable for an entrance lobby, a general study space or a learning studio.**

An open stair could be introduced to allow access to the upper level. This upper level would be restricted to the 7'-9" height. It would be best to leave the space undivided as it will be difficult to distribute fresh air to enclosed spaces. It should be clear that the remainder of the lower level would remain as book stacks as it still supports this upper level.

The advantage of such a conversion is that it would be relatively easy to accomplish from a construction point of view.

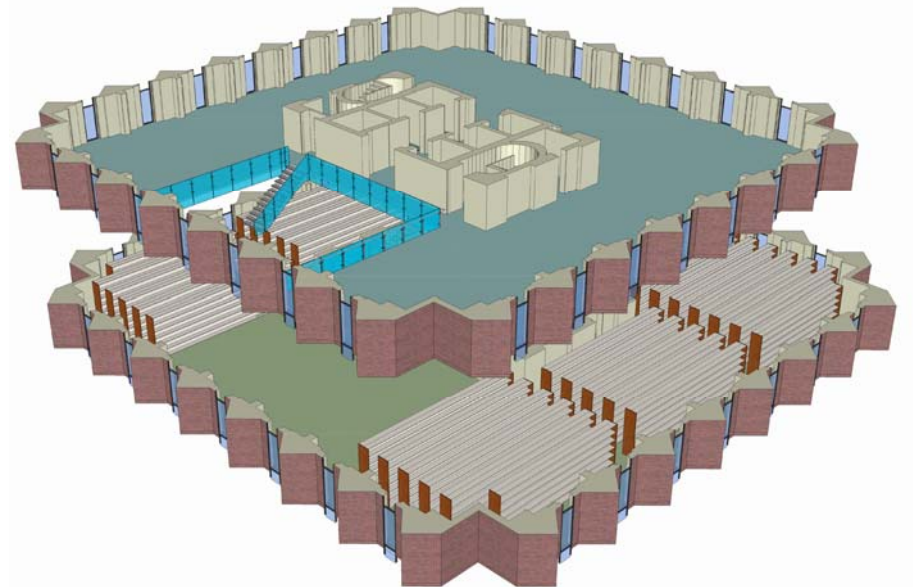

## 3.4 OPPORTUNITIES FOR RENOVATION DU BOIS – STACK FLOOR RESTRUCTURING

### Stack Floor Restructuring

It would also be possible to remove all of the book stacks and supported slab from a pair of adjacent stack floors. **This would provide an open space that was 18'-6" in clear height.** This space could be either partially in-filled or totally in-filled with a new steel supported floor structure. The clear height between the new floors would still only be 7'-9" but the resulting spaces could be used for any function that could fit in such a vertically restricted space.

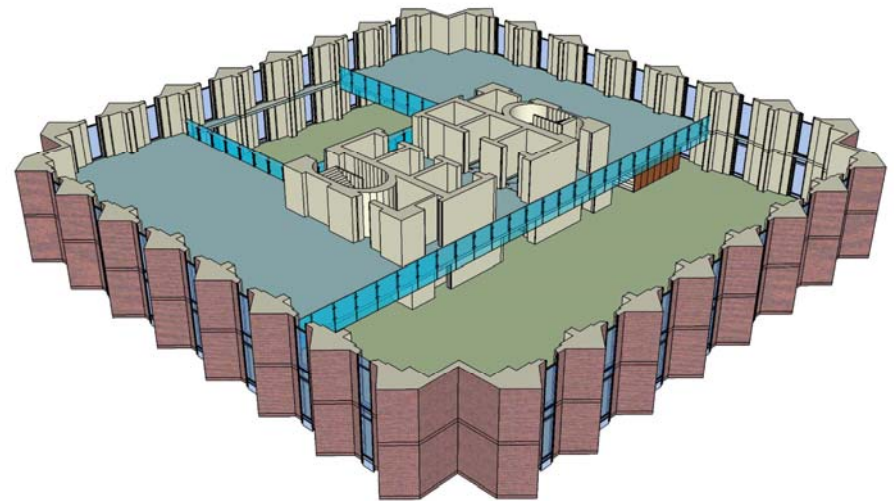



## 3.4 OPPORTUNITIES FOR RENOVATION DU BOIS – EXISTING STEEL SUPPORTED FLOOR RESTRUCTURED

### Existing Steel Supported Floor Restructured

Levels three and six of the tower were originally intended to be stack floors but were not installed during the original construction. Instead these floors were retrofitted at a later date as infill steel supported floors with standard beam and slab construction. While these floors still have the dimensional restrictions of the stack floors, as explained elsewhere they are not encumbered by the necessity of removing the stacks and stack-supported floors. The same sort of program that is possible for stack floor redevelopment would be more easily accomplished on these floors including levels 2, 3, 5 and 6.

The adjacent diagram shows a possible development of one of these pairs of floors into large and small classrooms by removing the steel supported portions of the floor. Additionally, because these floors have an additional circulation stair running from the entry level to the 5<sup>th</sup> floor, these floors would easily accommodate a possible bridge connection to a new building addition.

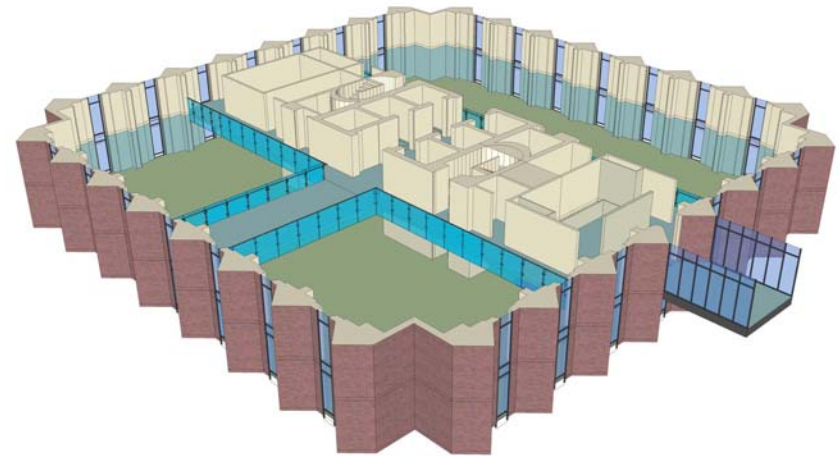





## 3.4 OPPORTUNITIES FOR RENOVATION DU BOIS/GOODELL

### Renovation at the Lower Level Du Bois

Given the location, the 12'-0" clear floor to floor height and large amount of contiguous space at the Lower Level it would be appropriate to take advantage of this space for functions that have special requirements. Recently this space was renovated for the Learning Commons successfully. Moving library staff space, for example, to upper levels in the tower when feasible and converting the space to user seating would be an example of how to take advantage of this opportunity.

### Compact Shelving in Basement Level Goodell

Goodell originally functioned as the main library building. It is located approximately 200 yards from the Du Bois building. Currently there is 9,000 SF of regular book stacks located on the 2<sup>nd</sup> Floor. This study looked at the possibility of additional book storage in Goodell.

The following diagrams shows the possibility of providing compact shelving on the 1<sup>st</sup> Floor of the new addition and on the lowest floor of the original stack areas on the 4<sup>th</sup> Floor. Additionally since the stack areas are constructed separately from the original building it would be possible to remove the stack structure entirely and reconstruct all these floors to accommodate the additional loads for compact shelving.

# 3.4 OPPORTUNITIES FOR RENOVATION GOODELL LEVELS 1 AND 2

## Option for Compact Shelving in Basement Level of Goodell Building

Goodell originally functioned as the main library building. This study looked at the possibility of additional book storage or administrative functions on various levels of Goodell.

The diagrams to the right show the possibility of providing compact shelving on the 1<sup>st</sup> floor of the addition. Additionally since the stack areas are constructed separately from the original building, it would be possible to remove the stack structure entirely and reconstruct all these floors to accommodate the additional loads for compact shelving.

Currently there is 7,254 SF of book storage located on the 2<sup>nd</sup> floor. The 2<sup>nd</sup> floor, however, would not be able to support compact shelving.



# 3.4 OPPORTUNITIES FOR RENOVATION GOODELL LEVELS 3 AND 4

Potential space on the 3<sup>rd</sup> floor and 4<sup>th</sup> floor will not support compact shelving and are candidates for other potential functions.

Room 409 at the base of the original stacks on the 4<sup>th</sup> floor could, however, be convertible to compact shelving use if needed.

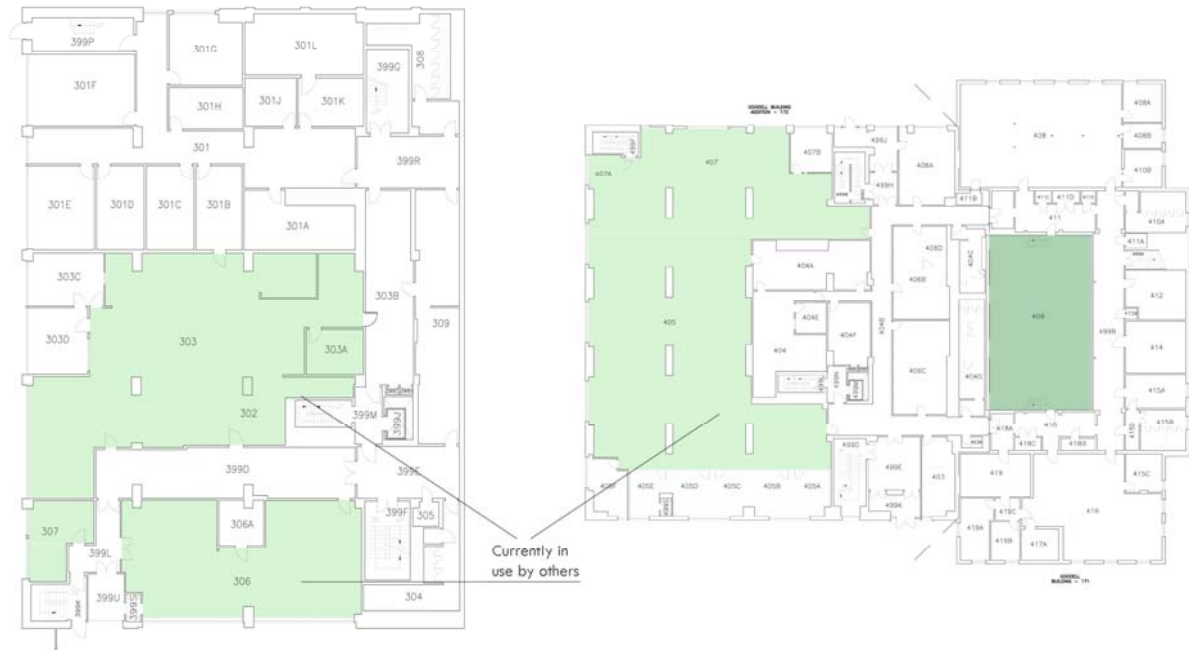

**THIRD FLOOR PLAN**  
 room 303: 2,400 sq. ft  
 307: 224 sq. ft  
 306: 1,325 sq.ft

**FOURTH FLOOR PLAN**  
 room 409: 2,056 sq. ft  
 405: 4,775 sq. ft  
 407: 2,684 sq ft

	GENERAL BOOK STACKS
	COMPACT SHELVING

# 3.4 OPPORTUNITIES FOR RENOVATION GOODELL LEVELS 5 AND 6

The 5<sup>th</sup> and 6<sup>th</sup> floors have additional space in the original stack zone. These areas cannot support compact shelving and do not have stacks in them today, though, so would need to be fitted up.

It is possible that stacks removed from other spaces could be relocated and installed in Goodell temporarily but the expense of doing this may not be worth the capacity gained. Unless proper environmental controls can be installed, the stability of the print materials will be at more risk than they would in an off-site storage facility.

Fragmenting the collections into many smaller spaces is not desirable and will be operationally inefficient.

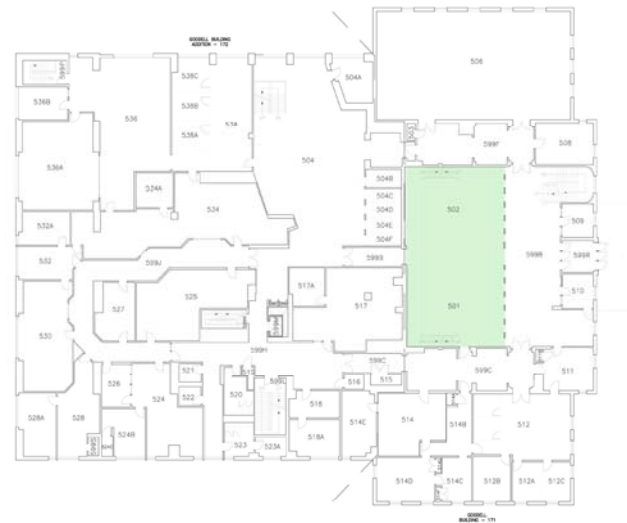

FIFTH FLOOR PLAN  
room 501/502: 2,056 sq. ft

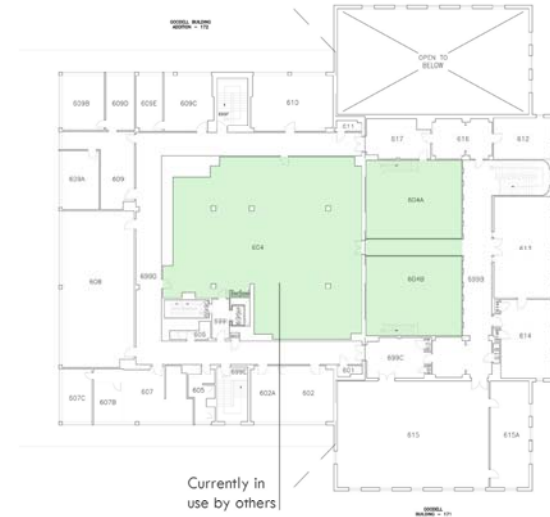

Currently in use by others

SIXTH FLOOR PLAN  
room 604: 3,636 sq. ft  
604A/604B: 2,056 sq ft

	GENERAL BOOK STACKS
	COMPACT SHELVING

## 3.4 OPPORTUNITIES FOR RENOVATION DU BOIS – COURTYARD DEVELOPMENT

### Courtyard Enclosure

One of the options to provide more useable space at the Lower Level of the library would be the infill of the existing exterior courtyard area. Because it is contiguous with the main level of the library one could argue that the courtyard is underutilized area in a location that will need opportunity for expansion as pressure increases on the library to provide more study space.

The diagram at the right shows an infill option with two team based learning classrooms that provides some direct sun and adjacent green areas, while creating circulation corridors and opportunities for enclosed floor plate expansion. The space could also easily be used for additional study space or other meeting functions.

However, difficulties with this option are the cost of the roofing, which would be highly visible and need to be detailed carefully, perhaps as a green roof; loss of the landscaped court as visual relief for Commons users and staff; and significant reduction of natural light into the Learning Commons. These issues would have to be addressed during the development of such an option. Additionally columns would likely have to be added through the basement storage level.

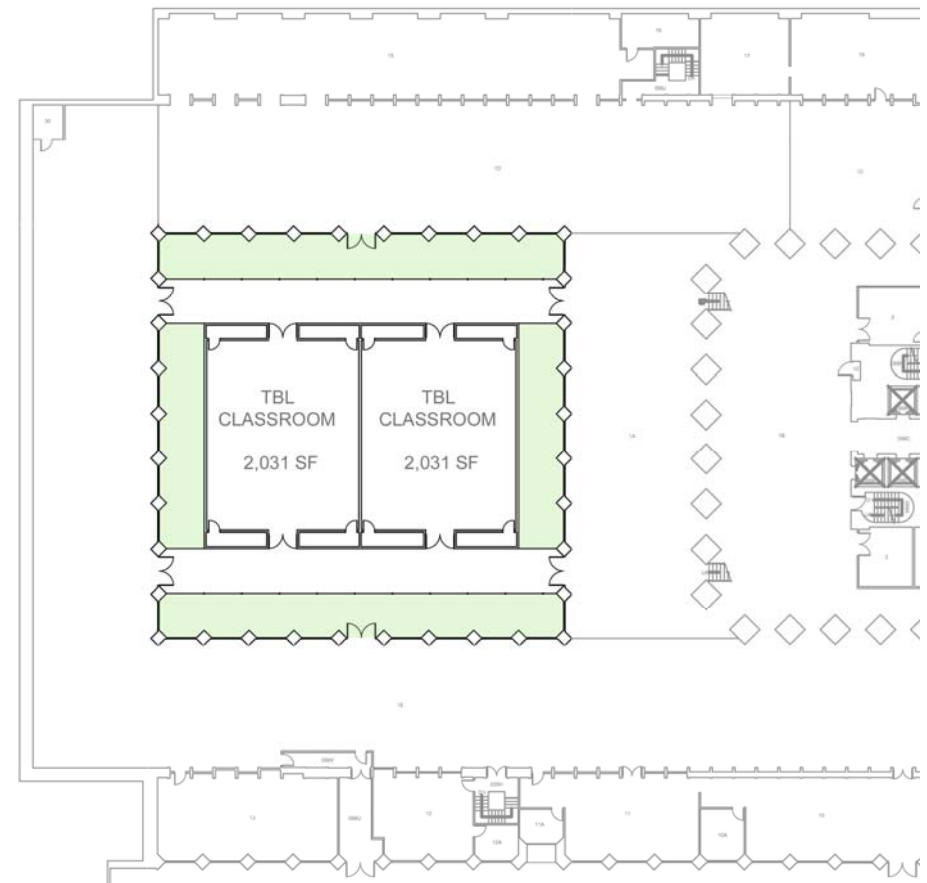



## 3.4 OPPORTUNITIES FOR NEW CONSTRUCTION DU BOIS

It might seem counterintuitive to suggest that it would be prudent to build new space for the library given that much of this study is about re-purposing existing space in the library tower. There are several important aspects of the existing library building, and the future planning for the library and the surrounding campus that are worth discussing in this context.

### Growth of the Learning Commons:

Much has been said of the difficulty of repurposing the tower space and its relative unsuitability for reuse for many functions. The huge success of the Learning Commons at the Lower Level of the library is clear to even the most casual observer. Only a year after its opening there are long waiting lines for seats. **There is every reason to believe that the future new demand will require additional contiguous space that can be easily served by the existing library staff functions on that floor.**

### Swing Space for Construction Activities

One of the major difficulties in renovating the existing library will be to find space to relocate Library functions while sizable areas of the Tower are being renovated. **New construction could solve this need for temporary swing space.**



## 3.4

# OPPORTUNITIES FOR NEW CONSTRUCTION DU BOIS

### Potential Addition to Lower Levels of Du Bois

The recent Comprehensive Academic & Classroom Facilities Plan documented the lack of suitable classroom space for certain classroom types and sizes on the UMass Amherst Campus. Existing classroom space is at a premium and it is clear that new classrooms need to be built. **One of the sites that has been identified, is abutting the library to the Northeast. This location has strong appeal for its central location and its adjacency to conference and study space in the library.**

### New Wing at Plaza

While the Dubois Library has always provided an iconic image from afar for the university, its ability to provide a friendly environment for campus users close up has never been good. The plaza created by the tower base is barren and windswept despite efforts to make it habitable and it turns its back to the central campus axis created along the pond edge between the campus center and the arts building. **A new 3 to 4 story building, as illustrated in the adjacent diagram, would enclose the plaza, create life along the pond edge and attach to the library building by bridge at the most public tower levels.**

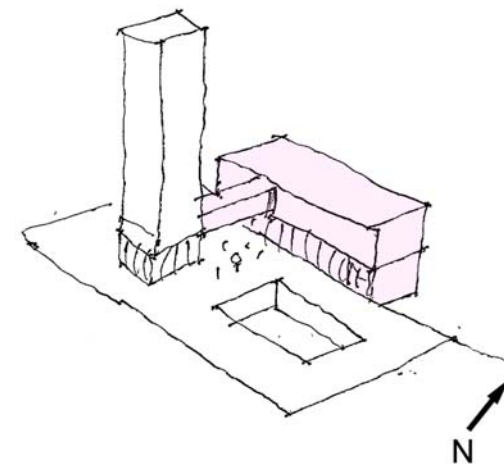
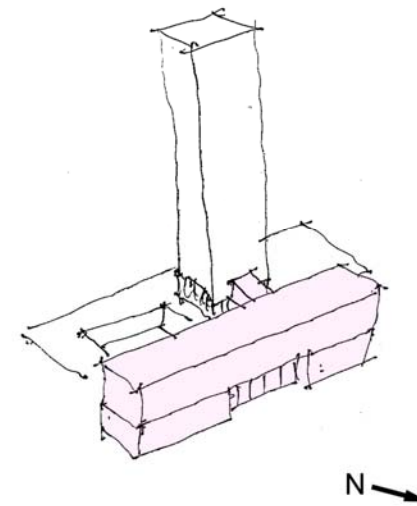

## 3.4 OPPORTUNITIES FOR NEW CONSTRUCTION DU BOIS – UNDERGROUND BOOK STORAGE

### Underground Book Storage

Many of other university libraries have used underground facilities for storing books on existing campuses. Rather than moving books off the campus it could make sense to take advantage of such an opportunity at UMass Amherst.

Between Goodell and Du Bois it is possible to envision an underground storage facility that would connect the two buildings. The accompanying diagram suggests the facility could provide space for 35,000 SF of storage at a height of perhaps 10 to 12 feet. This could accommodate 500,000 volumes in a compact shelving arrangement.

This storage area could also be accessed through the existing loading dock at Goodell.



Underground Storage Option

## 3.4 OFF-CAMPUS OPPORTUNITIES OPPORTUNITIES FOR BOOK STORAGE

### Compact Shelving in Off-Site Warehousing

The possibility of providing storage for books in leased warehouse space has been discussed. This analysis assumes that books would be moved to such a facility for a significant amount of time and that the space would be upgraded to meet climate control and security concerns.

### New Offsite High Density Book Storage Facility or Five College Storage Facility Expansion

Building a new book storage facility is a long term solution for book storage that has been undertaken by many institutions. Some of these facilities store books in bins, rather than shelves so that books can be automatically retrieved by computer controlled mechanical devices. Other facilities provide high density solutions with similar automatic retrieval mechanisms. These facilities are climate controlled and are built with high bay spaces so that the best efficiencies can be obtained.

Another option is to continue to leverage the existing arrangement in the Five College Storage Facility. This might include investment in a new facility group facility.

The study of these options should include not only the capital cost of such a facility but also the long term operations and sustainability costs.

# 4

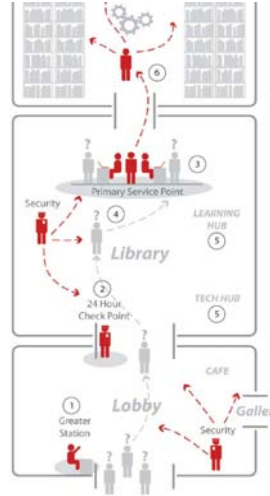

## VISION FOR THE FUTURE LIBRARIES

Drivers for Planning  
Aspirations  
Visioning





## 4 VISION FOR THE FUTURE LIBRARIES

The Visioning process engaged many people in workshops and focus groups, from the Library's Senior Management Group to faculty, researchers, graduate and undergraduate users, administrators and representatives of potential compatible uses. The findings from various workshop exercises are summarized here, including a SWOT analysis, alternative future scenarios modeling, envisioning future learning experiences, and developing measures of future success.

Campus leaders were interviewed for their perspectives on the future learning landscape at UMass Amherst and the library's role in that future. Common themes and strategic directions emerged around fostering interaction, encouraging and supporting new teaching modes, and building community.

A summary of aspirations by theme was developed from the input from the process. The trends and forces for change are outlined together with the future implications for planning.

***"We live in perpetual beta..."***

*--librarian in workshop*

*"The library is seen as a neutral place to integrate scholarship and teaching across disciplines."*

*--faculty member*

*"Much faculty research collaboration today is with fellow researchers at other universities, both here and abroad."*

*--faculty member*



# UMASS DRIVERS FOR LIBRARY PLANNING

## INSTITUTIONAL DRIVERS

At UMass there are strategic shifts currently underway that will change demands on future library services and facilities. Strategies and concepts for the master plan were developed to respond to these drivers:

- **University aspirations to become a major research university** are targeting new areas for research development, with associated growth in student population (especially for out of state undergraduates, continuing ed, advanced degrees) and faculty to generate research and teach,
- **Strategic planning is targeting increases in sponsored research** to offset budget constraints from traditional revenue sources. Increasingly research will involve undergraduates as well as graduate students. The Library will need to support the growth in research activities.
- **Changes to the Gen Ed curriculum are being introduced**, with a shift from 3 credit hour to 4 credit hour courses. It is anticipated that the increase will be accommodated not with additional “seat time” in physical space, but with online work. This will place added demands on the libraries to serve remote users and to provide more seats to work productively in library facilities, which is often not feasible in the residence halls.
- **Institutional desire to transition to more active learning** for better learning experiences and outcomes, with more classes engaged in team based learning rather than didactic lectures. The library can become a center demonstrating best practice with shared prototype spaces.
- **New types of digital scholarship and teaching** are starting to be developed by faculty in the humanities and social sciences. The library is interested in fostering innovation in new uses of information and scholarly technologies to help UMass Amherst become a leading research institution in the 21<sup>st</sup> Century.
- **Lack of space to accommodate growth** into next decade, with pressures for all types of space on campus—classrooms, academic and research space, the libraries and their collections.
- **Continuing shortages of funding and staffing**, coupled with aging or outdated infrastructure. Having completed extensive studies of its sciences and academic facilities, UMass Amherst is currently working on a master plan framework to address these deficiencies that will guide planning until a full master plan can be developed and implemented.

# FORCES FOR CHANGE ON LIBRARIES

## FORCES IMPACTING LIBRARIES

- **Increasing mobility** of users of library resources and services enabled by mobile technologies
- **New access paradigms:** library users want to browse, search and access collections and get assistance remotely
- **New teaching and learning approaches** are developing, such as active team-based and experiential learning, which require students to access library resources during class sessions and to do more team projects outside of class that require collaboration to co-create products.
- **More users are getting involved in “digital making”** with media—what would once have been a paper may now be a podcast or YouTube clip
- **Data-driven research and e-science on the rise**, with new imperatives for curation of institutional research data
- **User demands for new types of services and support**, greater mobility and collaboration with information resources

## TRENDS IN HOW LIBRARIES ARE RESPONDING

- **Shifting the balance from stacks to more user space** with less print collections stored on-campus while still maintaining convenient access to materials
- **Providing more collaborative space** for study, learning and research rather than quiet individual spaces, while still ensuring access to quiet, sanctuary library spaces
- **Libraries evolving into Learning Centers**, incorporating teaching space and a wide variety of learning support services
- **Responding to an increase in usage with the introduction of problem-based and team-based learning programs**, as more group learning activity shifts to out-of-classroom settings
- **Playing an increasingly important role in fostering academic interaction** and community building, providing places for informal sharing with peers
- **Developing new roles for librarians with the shift to electronic resources**, balanced with continued responsibility for curation of physical collections and legacy media

# SWOT ANALYSIS FOR THE LIBRARY

## STRENGTHS

**Location** - central to campus  
Very professional and highly knowledgeable staff  
**Open 24 hours**  
Staying ahead in terms of technology  
Capitalizing on opportunities  
**Best collections of a public research institution in the Commonwealth**  
**Leadership to Five Colleges Consortium**  
Interaction with other libraries  
Not a stagnant organization

## OPPORTUNITIES

**Centralized services/collaboration within Five Colleges Consortium**  
**Opportunities for partnerships with faculty**  
**Technology allows more collaboration**  
Develop image/brand of library  
**Increased funding for science research**  
**More active role for publications, conference, etc.**  
Classroom support through streaming media  
Develop interface to the Library resources  
Better serve research in the upper levels while redesigning the lower levels to serve a general population

## WEAKNESSES

Lack of adequate funding is a historical trend  
Lack of space - collections currently at capacity  
**Building limitations**  
Irrational design for library  
Limitation of elevators, no service elevator  
**Lack of flexibility for 21st century services in the building**  
Science Library too small for students & technology needs  
Not enough restrooms, custodial and infrastructure (electricity, HVAC)

## THREATS

**Lost opportunities due to budget cuts**  
**Lack of enterprise infrastructure for technical collaboration**  
**Lack of cultural support for multi-disciplinary and multi-unit collaboration**  
Damaging perceptions  
Availability of research is limited in the reserve collection  
Aging support staff and potential loss of collective expertise



# ALTERNATIVE FUTURE SCENARIOS

Scenario planning enables the imagining of alternative futures in response to major drivers, unknown forces and predetermined elements. It allows exploration in a structured way of multiple scenarios and how radically different futures might play out and what influences they might have on users, services, collections and space. The insights gained help inform development of a future vision to allow resiliency to respond to future forces.

As part of the visioning workshop process, the Library's Senior Management Group outlined drivers that would affect the future of the libraries. Scenarios were then created by breaking out into small groups and selecting two different sets of drivers each (selected ones shown in red). The intersection of the pairs of drivers created a grid with four quadrants that each defined a different story about the future. Each group discussed the impacts their drivers would have on users, services, collections, and spaces, and then identified where they believed the library was positioned today and indicated the desired future direction for the library. One sample is included on the following page.

## POTENTIAL DRIVERS

Cloud Computing	Local Computing
<b>Fewer Students</b>	<b>Increased Students</b>
Opportunistic Survival	Sustainable Institutional Support
University as Publisher	Scholar as Publisher
<b>Proactive Climate</b>	<b>Reactive Climate</b>
Difficult Budget Climate	Economic Improvement
Independent Operations	Leveraged Partnerships
Slow Growth in e-Science	Rapid Growth in e-Science
Google Dominated Future	Networks of Scholars
Retrospective Responsibility	Future Oriented Leadership
<b>Decreased Resources</b>	<b>Increased Resources</b>
Erosion of Traditional University	Emergence of Learning Communities
<b>Ownership of Resources</b>	<b>Licensed Access</b>
Traditional Forms of Scholarship	Digital Humanities Initiatives
<b>Preservation of Resources</b>	<b>Engagement in Knowledge Creation</b>
Institutional Commitment to Invest	Institutional Constraints in Investment
Dependence on Capital Initiatives	Multiple Revenue Sources
<b>Library as Scholar's Sanctuary</b>	<b>Library as Collaborative Center</b>
Balance between Traditional and Computational Research	Explosive Growth in Data Intensive Research

# ALTERNATIVE LIBRARY FUTURES

## SAMPLE: LIBRARY AS SANCTUARY VS. COLLABORATIVE CENTER

### ENGAGEMENT IN KNOWLEDGE CREATION

#### SANCTUARY FOR CREATION

**Users:** More graduate students and faculty

**Services:** More technical support for individuals, students and faculty, e.g. Writing Center, etc.

**Collections:** Expanded collections. Support for digital access.

**Spaces:** More specialized carrels. More extensive network support. Smaller spaces, quieter spaces, higher proportion of individual to collaborative seating.

#### COLLABORATIVE HUB FOR DIGITAL CREATION

**Users:** Undergraduate and graduate students, faculty, community, global partners/groups

**Services:** Increased technical support related to digital and production devices. Support for collaborative production/ creation - tools, etc.

**Collections:** New forms of equipment as collections - supporting multi-media creation, etc. More off-site storage of collections.

**Spaces:** Research Commons, Teaching Commons, multi-media creation. Higher proportion of collaborative vs individual seating.

#### LIBRARY AS MUSEUM

**Users:** Faculty generating new research that has special preservation requirements

**Services:** Archival expertise, experience with preservation techniques, online teaching

**Collections:** More space for collections acquisitions, expanded Special Collections, variety in media. More donations/collection for exhibit. Need to preserve drives increase in Institutional Repository.

**Spaces:** More environmentally controlled space for archiving and exhibition

#### COLLABORATIVE CENTER FOR PRESERVATION

**Users:** Faculty ( who need help with preservation of research), students, Five Colleges, global researchers.

**Services:** Increase in digitization and access to teach students (craft of preservation), use of library resources, online teaching, preservation of data sets

**Collections:** Expanded physical and digital collections, preservation of institutional repository, e-Science growth and "metalloggers"

**Spaces:** More equipment to read new and old formats. Larger collaborative spaces.

### PRESERVATION OF RESOURCES

SCHOLAR'S SANCTUARY

COLLABORATIVE CENTER

# SUPPORT FOR RESEARCH ASPIRATIONS BY THEME

TRENDS AND FORCES FOR CHANGE	FUTURE IMPLICATIONS FOR PLANNING
<ul style="list-style-type: none"> <li>• Research is <b>becoming inter-disciplinary and international</b>, but research staff are often silo'ed as the campus is highly compartmentalized, so there is a need to bring researchers together. UMass Amherst is encouraging internal proposals for funding by interdisciplinary research teams to incentivize innovation.</li> <li>• UMass's biggest <b>focus is on basic research</b> (rather than applied), with NSF as the biggest funding agency. Many grants now require dissemination of research data.</li> <li>• Currently about one-third of undergrads have some kind of research experience, and that is growing. The institution has a strategic goal to transform the undergraduate experience and <b>encourage undergraduates to participate in guided research</b></li> <li>• <b>Need to develop new kinds of services to respond to increasingly data intensive research.</b></li> <li>• <b>A research commons would play a valuable role in getting researchers together</b>, as found with recent well attended forums on seeking grants.</li> <li>• <b>There is a need to make research more visible</b> by showcasing and celebrating the products of research.</li> </ul>	<ul style="list-style-type: none"> <li>• The Library can become a <b>neutral ground on campus to draw researchers together</b> offering collaborative workspace</li> <li>• Library staff can provide <b>new support services for research</b>: data curation; data services for GIS and other resources; consulting on copyright/IP, publication issues and responsible conduct of research; and potentially future data services such as data mining, statistical analysis, and dataset management.</li> <li>• <b>Centralize services in a Research Commons partnering with Research &amp; Engagement</b></li> <li>• <b>Provide spaces with equipment to enable communication and sharing with remote research colleagues</b></li> <li>• <b>Support undergraduate as well as graduate research</b></li> <li>• The Library can make parts of collections more visible on topics of interest, encouraging browsing and interdisciplinary explorations.</li> </ul>

# SUPPORT FOR SCHOLARSHIP ASPIRATIONS BY THEME

TRENDS AND FORCES FOR CHANGE	FUTURE IMPLICATIONS FOR PLANNING
<ul style="list-style-type: none"> <li>• <b>Digital scholarship is emerging in the humanities and social sciences</b>, as well as in science and engineering</li> <li>• <b>Use and browsing of the print collections will continue to be important to certain disciplines</b>, especially in the humanities. For example, History faculty regard the library as their “lab” to access historical material (e.g. in the extensive microfilm records which can only be used in the library) and want to teach their students how to do research with print resources.</li> <li>• <b>There is increasing use of multimedia</b> in many disciplines for teaching, class projects and scholarly works.</li> <li>• <b>Rapid improvements in multimedia software will encourage increasingly complex and sophisticated multimedia creations</b> by students and faculty.</li> <li>• <b>Increasing demand for sharing and publishing scholarship</b> outside of the traditional publishing process. Potential for digital publication by institutions promises to share scholarship more widely and quickly.</li> </ul>	<ul style="list-style-type: none"> <li>• Du Bois Library to provide <b>leadership in support of digital humanities initiatives</b></li> <li>• Library to support the collection and <b>curation of datasets, media products and research documentation.</b></li> <li>• Increasing need for the Library to <b>develop and manage an institutional digital repository</b></li> <li>• <b>A one-stop center for assistance in working with digital resources to create digital projects</b>—with integrated support for information content, software and hardware use</li> <li>• <b>Support for individually owned devices and tools</b> for connectivity, mobile devices as effective delivery of content, support for <b>open access</b> approaches</li> <li>• Continued need for <b>quiet reading areas</b> to examine materials and work on them.</li> </ul>

# SUPPORT FOR LIBRARY DEVELOPMENT ASPIRATIONS BY THEME

TRENDS AND FORCES FOR CHANGE	FUTURE IMPLICATIONS FOR PLANNING
<ul style="list-style-type: none"> <li>• <b>Pressures to acquire new skills</b> and develop new tools for management of electronic resources</li> <li>• <b>Shifting from processing of print materials to management of electronic resources</b>, licenses and access issues</li> <li>• <b>Publication of datasets along with research findings</b></li> <li>• <b>Growth of digital humanities and data intensive research in the social sciences</b></li> <li>• <b>Geosciences developing increasingly sophisticated systems for information analysis</b></li> <li>• <b>Increasing use of digital media in teaching, scholarship, student projects and research</b></li> <li>• <b>Demand for more online course materials with increase in blended learning courses over next decade</b></li> </ul>	<ul style="list-style-type: none"> <li>• <b>Ongoing professional development needs</b> to stay ahead of a changing research and publication environment, shifting “<b>from cataloging to metaloging</b>”</li> <li>• <b>Need for redefinition of roles and improved adjacencies</b> for groups that will be collaborating more in the next decade</li> <li>• <b>Focus on greater proficiency in disciplinary knowledge and ways of using information</b>, such as in emerging areas of e-science or informatics</li> <li>• <b>More staff involved with data curation, data services and scholarly communications</b></li> <li>• <b>Better facilities, equipment, systems and trained staff for providing data services</b></li> <li>• <b>Transition from map collections to GIS based resources</b>, and training of staff conversant with both</li> <li>• <b>Better facilities and staffing to assist users in finding and integrating media resources into their work</b>, and developing media collections</li> <li>• <b>Facilities to support staff proficiency in development of learning objects, web-based and network accessible resources, improved user interfaces and usability testing.</b></li> </ul>



# SUPPORT FOR LEARNING ASPIRATIONS BY THEME

TRENDS AND FORCES FOR CHANGE	FUTURE IMPLICATIONS FOR PLANNING
<ul style="list-style-type: none"> <li>• Growth in enrollment will move UMass pedagogy more <b>towards blended course delivery</b>, combining face to face and online. The additional credit hours in the recent change in the General Education courses, from 3 to 4 credit hours, will for the most part be added through online activities.</li> <li>• <b>Increase in interdisciplinary teaching</b> and courses</li> <li>• Blended courses will create <b>demand for active learning spaces</b> that encourage a diversity of teaching styles: <i>“As distributed learning trends are becoming popular, there is a need to support activities like testing and problem based learning”</i></li> <li>• <b>Demand for peer to peer learning is increasing</b> as faculty is encouraging collaborative learning in the classroom.</li> <li>• <b>Campus lacks informal learning spaces</b> that support out of classroom learning and encourage collaboration between students and faculty: <i>“People venue shop for informal spaces to work based on the support services available.”</i> Students commented on a lack of spaces across campus to do work with peers, aside from a few building lobbies.”</li> </ul>	<ul style="list-style-type: none"> <li>• <b>Support faculty training</b> for new curriculum development, use of teaching tools etc.</li> <li>• <b>Formal learning spaces to accommodate varying teaching modalities</b></li> <li>• <b>Enable peer to peer learning</b> by providing spaces to learn outside of teaching spaces</li> <li>• <b>Provide state-of-the-art connectivity and visualization facilities</b> as shared resources across disciplines</li> <li>• <b>Support faculty/scholar mobility</b> by providing flexible meeting spaces on neutral ground with storage facilities, cloud computing with access to software via the web</li> <li>• In the future the focus will be to <b>support distributed learning and collaboration</b>, with emphasis on supporting individual devices/tools for connectivity and effective delivery of content.</li> </ul>

# SUPPORT FOR FACULTY DEVELOPMENT ASPIRATIONS BY THEME

TRENDS AND FORCES FOR CHANGE	FUTURE IMPLICATIONS FOR PLANNING
<ul style="list-style-type: none"> <li>• <b>Trend to more interdisciplinary teaching teams</b></li> <li>• <b>Need for a central place for faculty to go for consultation in curriculum development</b>—for help in creating new digital course materials, for training in new teaching tools, and to share experiences with peers.</li> <li>• <b>Faculty across disciplines are using multi-media</b> for course delivery and will require both physical and virtual support for the production of material as they teach in a digital environment</li> <li>• <b>Moving to more blended course delivery</b> will require more faculty training and support in new teaching styles</li> <li>• <b>Increasing mobility of faculty</b> and where they chose to work</li> <li>• <i>“Most faculty collaboration happens off-campus, out of state and even with fellow researchers in other countries”.</i></li> </ul>	<ul style="list-style-type: none"> <li>• “The library is seen as a <b>neutral space to integrate scholarship and teaching across disciplines</b>”.</li> <li>• <b>Support faculty in teaching with information resources and creation of digital course materials with library resources and expertise</b>, through enhanced partnership with the Teaching Commons</li> <li>• <b>Librarians to assist faculty with creation of online course material</b> and effective use of new information resources</li> <li>• Support faculty and scholar mobility by providing <b>flexible meeting spaces</b> in the library to connect with groups in other disciplines or meet to do research with <b>students—spaces that support ‘hoteling’</b></li> <li>• Classrooms that provide greater flexibility to accommodate variety in teaching modalities. The library can provide <b>model learning studio prototypes</b>, coordinating with the Teaching Commons.</li> </ul>

# SUPPORT FOR UNDERGRADUATE STUDENTS ASPIRATIONS BY THEME

TRENDS AND FORCES FOR CHANGE	FUTURE IMPLICATIONS FOR PLANNING
<ul style="list-style-type: none"> <li>• <b>Mobility</b> enabled by personal devices</li> <li>• <b>Increasingly proficiency in use of media</b></li> <li>• Comfortable with <b>blended activities, multitasking</b></li> <li>• <b>Activity 24/7</b>; after hours and nighttime activity peaks; increasing number of students abroad participating from other time zones with globalized curriculum</li> <li>• <b>Less likely to turn to print resources</b> initially, lack of awareness of value of print materials</li> <li>• <b>Just in time learners</b>, expectations for instant information</li> <li>• <b>Like learning collaboratively with peers</b></li> <li>• <b>Need quiet work space to escape</b> noisy residences and classroom areas, yet have desire to see and be seen, like working alone together</li> <li>• <b>Assistance when they want it, accessible virtually</b></li> <li>• <b>Serious gaming</b>, increasing use as a teaching tool</li> </ul>	<ul style="list-style-type: none"> <li>• <b>Demand for power and greater bandwidth</b> throughout the library facilities</li> <li>• <b>Comfortable flexible seating</b> areas with movable furnishings, whiteboards on wheels</li> <li>• <b>Café food services available into the evening hours</b> for taking a break from studying without having to pack up and go to another building</li> <li>• <b>Clearer orientation and signage systems</b>, so students are more comfortable navigating around Du Bois</li> <li>• <b>Convenient service points</b> in the Learning Commons, with integrated services for one-stop help, plus virtual help</li> <li>• <b>Group study settings bookable online</b>, and online maps tracking seating in use throughout the building to reduce time looking for seating</li> <li>• <b>Gaming area in library</b> (as in NCSU Hill Library Information Commons) which can be usable at other times for any group work activities that require large screens</li> </ul>

# SUPPORT FOR GRADUATE STUDENTS ASPIRATIONS BY THEME

TRENDS AND FORCES FOR CHANGE	FUTURE IMPLICATIONS FOR PLANNING
<ul style="list-style-type: none"> <li>• <b>Need to support online-only students better</b>, especially as they are likely to double in 10 years.</li> <li>• <b>Retention is a key issue at the graduate level</b> and needs to be addressed by better supporting the intellectual community and campus life at UMass.</li> <li>• <b>Growth in Masters programs is anticipated</b></li> <li>• <b>Certificate programs are growing</b> and this will contribute to more interdisciplinary work, more concentrated periods on campus</li> <li>• <b>Graduate students have a broad age span and have different kinds of needs</b>, spend years working on a dissertation, many hours of library use</li> <li>• <b>Targeted career services</b> for graduate students are needed</li> <li>• <b>Need to lower the barrier for participation in distance ed</b> – make it easy for students to skype into the class and design for what they have on their end, not what we want on ours</li> </ul>	<ul style="list-style-type: none"> <li>• <b>Target more services to graduate level students</b>, acknowledging their broad range of ages and work patterns</li> <li>• <b>Provide a place in the library dedicated to graduate students</b>, where they can meet with peers, as well as find a range of comfortable settings for individual study with lockable storage for research materials and personal tools</li> <li>• <b>Provide advising on research opportunities and career services for graduate students in the library</b> at one of the service points</li> <li>• <b>Support technologies to engage remote learners</b> in teaching and conferencing activities in the library</li> </ul>

# SUPPORT FOR STUDENT AFFAIRS & CAMPUS LIFE ASPIRATIONS BY THEME

TRENDS AND FORCES FOR CHANGE	FUTURE IMPLICATIONS FOR PLANNING
<ul style="list-style-type: none"> <li>• <b>Institutional aspiration to create a "living-learning" environment on campus</b>, as an effective Living-Learning environment could be a real distinguishing feature for UMass Amherst</li> <li>• <b>The Learning Commons is a successful model</b> for providing a space that is comfortable and collaborative — and one for students to see and be seen</li> <li>• <b>Residence halls lounges could become much better study space</b></li> <li>• <b>Blended learning could become a popular option</b>, e.g. watching a lecture then discussing it in class</li> <li>• <b>Students are asking for places to rest/de-stress</b></li> <li>• A detailed inventory of classrooms within residence halls is planned</li> </ul>	<ul style="list-style-type: none"> <li>• Study space in residential complexes needs improvement: <b>Potential to create distributed learning commons in residential complexes</b>, with a range of study settings for individual, collaborative workstations, and with <b>virtual connections to support services...</b></li> <li>• Increasing distributed learning capabilities in future may allow some students to opt to watch lectures remotely or asynchronously from residential complexes, then attend discussion sessions</li> <li>• Academic advising could also be provided in a distributed service model using virtual connections</li> </ul>



# FUTURE PROGRAM NEEDS

## SUMMARY OF FINDINGS BY GROUP

INSTITUTIONAL LEADERSHIP	LIBRARY SENIOR MANAGEMENT	COMPATIBLE USES GROUPS
<ul style="list-style-type: none"> <li>• The campus lacks a well distributed <b>network of spaces for collaboration outside of departments</b></li> <li>• <b>Graduate students</b> have a great need for some place they can identify with beyond their departments to connect with colleagues and faculty – provide ‘hoteling’ spaces for graduate students</li> <li>• <b>Lack of variety of learning space</b> types on campus that can accommodate diverse teaching activities</li> <li>• In the future UMA pedagogy is moving towards <b>team based learning</b></li> <li>• With more <b>interdisciplinary teaching</b>, faculty need to come together to share and create the curriculum</li> <li>• With increase in enrollment, demand for hybrid course delivery is increasing and the university will need <b>more secured testing centers.</b></li> </ul>	<ul style="list-style-type: none"> <li>• <b>A leadership role in the Five Colleges Consortium</b></li> <li>• <b>Library positioned to be “one stop shop for learners”</b> – making it the public face of the campus</li> <li>• <b>Provide 21<sup>st</sup> century library services</b> for users through partnerships and consortiums</li> <li>• <b>Partner with faculty</b> by understanding how the teaching needs are changing and how to better support them in the future</li> <li>• <b>Balance of individual and collaborative spaces</b></li> <li>• <i>“We live in perpetual beta”</i> - <b>more flexible spaces and approaches</b> to accommodate the changing technology advancements and user demands</li> <li>• <b>Robust liaison services and proactive initiatives</b> for researchers to support increasing cross-disciplinary work</li> <li>• <b>Train librarians to facilitate virtual and asynchronous activities</b></li> </ul>	<ul style="list-style-type: none"> <li>• <b>Need to enlarge the heavily used café and enhance</b> to encourage interaction and collaborative work</li> <li>• <b>Increase in online courses and distance learning will have spatial and support implications</b> (for course development and course capture)</li> <li>• <b>Consolidate and increase access to systems that are run by individual departments</b></li> </ul>

# FUTURE PROGRAM NEEDS

## SUMMARY OF FINDINGS BY GROUP

FACULTY	UNDERGRADUATES	GRADUATES
<ul style="list-style-type: none"> <li>• <b>More project-based lab courses will require more computing resources and support</b></li> <li>• <b>An increase in asynchronous learning must be balanced with more spaces for students and faculty to meet</b></li> <li>• <b>Blended courses have spatial and support implications</b>, but traditional items are still needed (chalkboards)</li> <li>• <b>Storage</b> space is needed for teaching materials and hands-on tools</li> <li>• <b>Spaces need to be flexible and accessible after hours</b></li> <li>• <b>The campus needs more distributed study space</b> for students to touchdown and work in between classes</li> <li>• <b>Encourage librarians and faculty to come together for course development</b></li> </ul>	<ul style="list-style-type: none"> <li>• <b>Need to increase interdisciplinary collaboration:</b> usually in clusters of students from the same major.</li> <li>• <b>Need to raise awareness of available work spaces</b></li> <li>• <b>Lack of spaces to go in-between classes:</b> there is a high demand for recreation / de-stressing/ inspirational space.</li> <li>• <b>Lack of distributed collaborative work areas:</b> collaborative work today is focused around the Campus Center, Student Union, and the Du Bois Library.</li> <li>• <b>Food &amp; beverage service is needed after hours</b> to support those studying at night.</li> </ul>	<ul style="list-style-type: none"> <li>• <b>Need for neutral “homebase” space:</b> graduates tend to live off campus and do not have a space on campus to come together, store materials, etc.</li> <li>• <b>Need to raise awareness of research initiatives on campus</b> so graduates can share knowledge on research procedures and best practices</li> <li>• <b>Need for more quiet study space:</b> research space separate from other functions and away from distractions</li> <li>• <b>Need to increase collaboration across disciplines</b> for knowledge sharing</li> <li>• <b>Need to provide a space for graduate students after hours</b> that has access to specialized software and support</li> </ul>

# HEADLINES FROM THE FUTURE

Workshop participants were asked to imagine a newspaper headline in the future once the Libraries' master plan was completed.

**“UMass Library Becomes Central Node in Massachusetts State Super Library”**

**“Data Jungle Under Control”**

**“Libraries Engaged in Partnerships with Researchers”**

*“UMass Library Gets New Building for the 21st Century —Dubois Tower Becomes New Administrative Support Center”*

“Acquisitions Budget Breaks \$15M Record”

**“Library Creates Different Types of Learning Spaces”**

“All U.Mass. Libraries' Materials Digitized”

“Students and Library Faculty Converse Simultaneously Online”

“During Storm Library Expands Digital Material Delivery”

**“Library Goes Mobile to Mobile”**

“Library Reaches Out Beyond It's Walls”

# MEASURES OF SUCCESS

LIBRARY LEADERSHIP	UNDERGRADUATES	GRADUATES
<ul style="list-style-type: none"> <li>• <b>Increase in percentage of the campus population that uses library facilities</b></li> <li>• <b>Higher volume of use</b> of library facilities, both electronic and physical</li> <li>• <b>Shorter waiting lines</b> for resources: computers, librarians, toilets, café</li> <li>• <b>Stronger relationships with faculty</b> - more instructional classrooms and collaborative work spaces</li> <li>• <b>Recognition by the institution that the Library is a core provider of valued services and needs adequate support</b></li> <li>• <b>A mechanism for sustainability</b>, so there is support/budget over time that can be relied on</li> <li>• <b>User satisfaction</b> with the facility and being able to analyze that separately</li> <li>• <b>Flexibility in space use</b></li> <li>• <b>Getting a new library building!</b></li> </ul>	<ul style="list-style-type: none"> <li>• <b>Amount of people using the library</b>, increase in the flow of people</li> <li>• <b>Services in demand are adapted to the demographics</b> of young library users</li> <li>• <b>Employees that are approachable</b> and helpful to students</li> <li>• <b>Maintaining good ratio of service to people</b> (in terms of service &amp; safety)</li> <li>• <b>Collections and reserves have adequate space</b></li> <li>• <b>Open feedback</b>, open dialog between users and librarians</li> <li>• <b>Better trained employees</b> (e.g. stacks group, reserves group)</li> </ul>	<ul style="list-style-type: none"> <li>• <b>Central place for collaborative work</b> that is conducive to discussion among graduate students</li> <li>• <b>Easy access to specialized staff</b> to help with research</li> <li>• <b>A stimulating atmosphere to work</b></li> <li>• <b>Awareness and ease of navigation</b> to library resources</li> <li>• <b>A comfortable place for individual and group work with resources nearby</b></li> <li>• <b>A variety of settings</b> and space to support a range of activities</li> <li>• <b>A destination for larger social events across disciplines</b></li> <li>• <b>24/7 support facilities</b></li> </ul>

# LIBRARY VISION SUMMARY

## SERVICES VISION

- **Improve research support by creating a research commons**, bringing specialist librarians together with scholarly communications librarians and developing new types of services, like data curation
- Continue to develop the **Learning Commons**, enriching its offerings as the primary study center on campus
- Continue to **explore partnerships** to offer integrated services and serve the campus more effectively, e.g. supporting the Teaching Commons
- Incorporate the Image Collections and music listening facility as part of a broader range of services to **support use of media collections**
- **Transition more staff from processing of print materials to management of digital resources**

## SPACE VISION

- **Convert underutilized space into new functions**
- **Relieve overcrowded stacks**
- Provide **more teaching facilities** to teach about library resources and digital literacy
- **Find the right balance between quiet individual settings and collaborative settings**
- Find the right balance between centrally scheduled classrooms and ones that can be bookable on demand and managed by the library, and find locations for them so their traffic does not disrupt library functions
- **Create special destinations** to draw users to the libraries

## COLLECTION VISION

- **House the UMass print collections in proper conditions with environmental controls**
- **Plan for adequate space to grow and highlight the Special Collections**
- **Shift underutilized materials** into off-campus storage as appropriate to make room for new uses
- **Consolidate several distributed collections** into Du Bois (e.g. Music listening room)
- **Enable browsing** of the most used portions of the collections and make accessible in Du Bois those collections that benefit most from mediated use
- **Determine a vision for the science & engineering library** in support of developments in e-science





# 5



## SPACE NEEDS ASSESSMENT

User Space Needs

Collections Needs

Library Staff Space Needs

Compatible Uses Space Needs



## 5 SPACE NEEDS ASSESSMENT

The space needs assessment process involved analyzing input from the user research, workshops and visioning process, and combining it with future projections for seating, collections, staff workplaces and compatible uses space needs. This chapter explains the assumptions and their impact on projected space requirements.

The primary driver, as explained in Chapter 4, is the University strategic initiative to grow the research sector, the size of the student body and to increase the General Education course credits, all of which will have ramifications for increasing demand for library services, resources and study seating. In addition, the proposed program also responds to pressure for other campus space needs and has incorporated compatible uses, such as teaching space, office space and expanded existing compatible uses. These needs have been summarized on the space program as:

- **Existing Space Use**
- **“Right-Sized” Program** – a theoretical calculation of today’s space needs based on assumed standards for typical types of spaces or assessment of existing atypical space. (This does not reflect the actual inefficiencies which may be generated by the need to fit into less than optimal layouts, such as some of the tower floors).
- **Proposed Program** – the proposed space program for 2020 reflecting where growth and change is projected, as well as the addition of new compatible uses and removal of some of the collections.

This chapter includes the following sections:

- 5.1 Summary of Existing Library Space Uses**
- 5.2 Projected User Facility Needs**
- 5.3 Collections Needs**
- 5.4 Library Staff Space Needs**
- 5.5 Compatible Uses Space Needs**
- 5.6 Learning Space Needs: The Learning Landscape Context**
- 5.7 Summary of Proposed Space Program**

*For the detailed breakdown of the space program, see the Appendix. The annotated breakdown compares existing, right-sized and projected 2020 space estimates by functional grouping.*

## 5.1 SUMMARY OF EXISTING SPACE USES

These tables summarize the breakdown of existing library space, both the whole system of library facilities and the Du Bois building in particular.

The library net figures are for usable area, or departmental suite net area including internal circulation, but do not include gross building circulation elements, cores and shafts, mechanical space, and compatible functions.

Existing Library System Facilities (usf)		
Du Bois Building	265,478	86.3%
Fine Arts Center	679	0.2%
Goddell Building Addition (Special Collections & UArchives)	7,295	2.4%
Integrated Science & Engineering Library	32,104	10.4%
South College loading dock	481	0.2%
<b>Existing Library Facilities*</b> <i>(dept'l nsf with internal circ'n)</i>	<b>307,614</b>	<b>100%</b>

Du Bois Building   Program Allocations (gsf)		
Building Core / Circulation	80,411	22.0%
Library	263,028	71.9%
Compatible Uses	22,251	6.1%
<b>Du Bois Total (gross sq. ft.)</b>	<b>365,690</b>	<b>100%</b>

Based on inventory data provided by UMass (11/18/09).

\* Not including compatible uses, cores, public circulation, mechanical, etc.

Du Bois Building   Library Space		
Support / Service	15,479	5.9%
Public / Social	889	0.3%
Collections	104,740	39.8%
Office/ Library Staff	35,416	13.5%
Study Space	79,397	30.2%
Library Meeting Room	1,942	0.7%
Classroom	3,244	1.2%
Storage/ Library	21,921	8.3%

Du Bois Building   Compatible Uses		
Computer/Telecom Srv	1,613	7.2%
Shop/Utility	2,167	9.7%
Café/Lounge	442	2.0%
Office/ Non-Library	7,677	34.5%
Study Space	504	2.3%
Meeting Room	1,689	7.6%
Classroom	7,044	31.7%
Storage	1,115	5.0%



# EXISTING SPACE USES IN DU BOIS

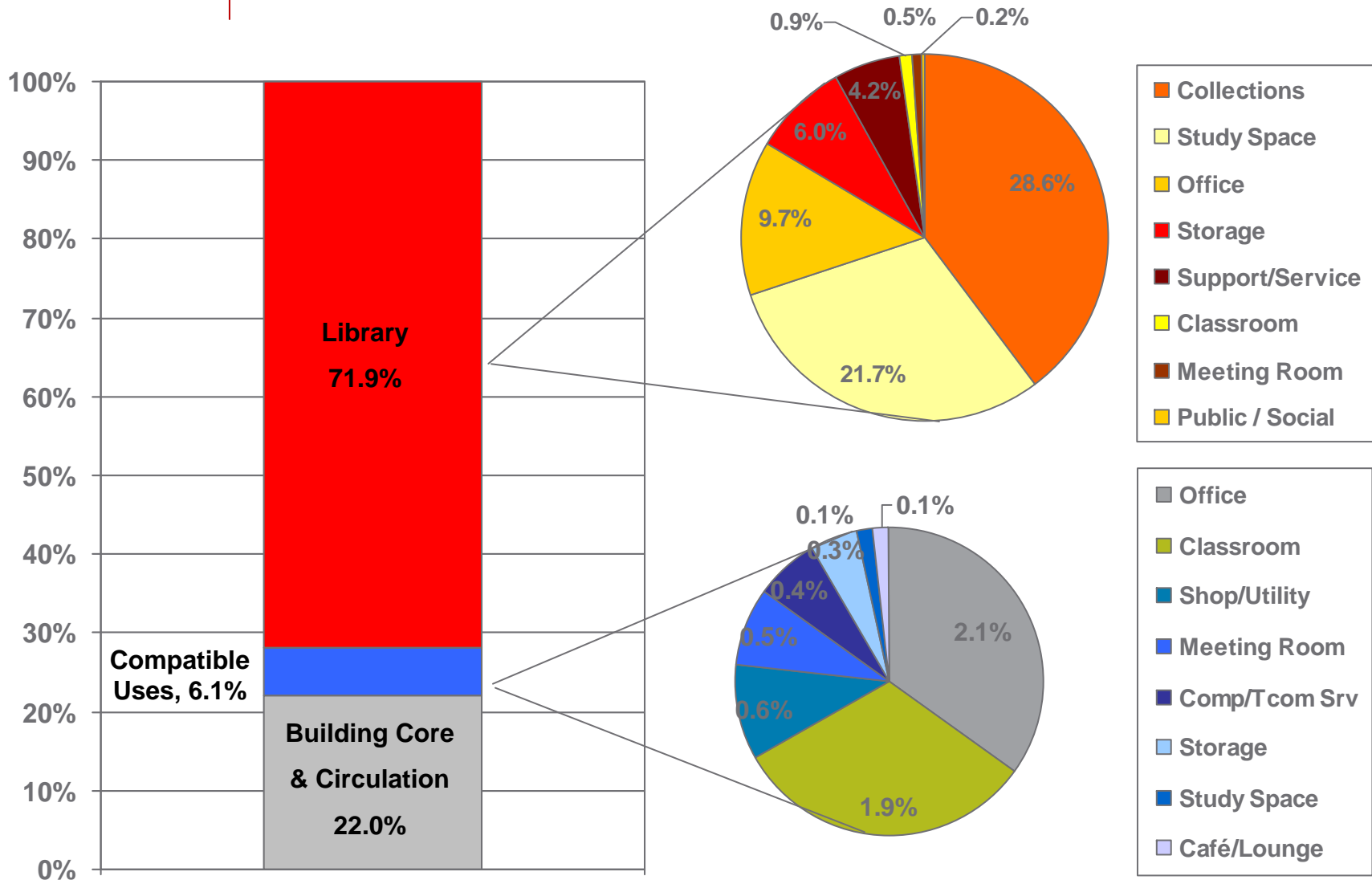

# PROGRAMMATIC NEEDS OF THE LIBRARY SUMMARY

Distilled from the workshops and user research, the primary programmatic needs of the Library emerged as:

- **A place to provide consultation on new types of digital scholarship, research and data curation services**, as a high profile Research Commons facility
- **Better facilities and services for graduate students**
- **More library instruction space**, as capacity of existing spaces is not adequate for certain courses
- **A central hub to work with media resources**
- **Improved user seating throughout with provision for anticipated population growth** over the next decade
- **Accommodation of growth in the general collections**, either in Du Bois or in off-site storage
- **Accommodation of growth in Special Collections** (which can grow in surges with gifts) and University Archives, and showcase the collections
- **Anticipation of future staff work space needs**, with shifting roles from print to electronic resources
- **Reexamination of service points**, given development of new facilities with specialized support needs

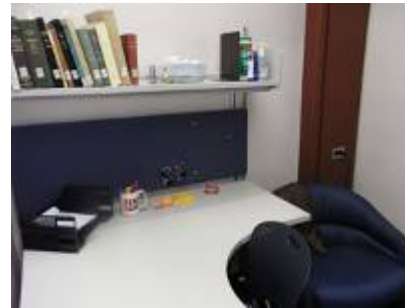

## 5.2 PROJECTED USER POPULATIONS IN 2020

The projected user population for a library helps define the amount of seating that should be provided. In this situation, as the success of the Learning Commons demonstrated, there will be greater demand for library seats if there are fewer alternative options for students elsewhere, especially for the type of collaborative and social study spaces in demand today.

Traditionally seating needs for libraries serving residential campuses could be predicted, but with the introduction of networked resources and mobile technologies, study and access to library resources can happen anywhere, so the old standards no longer apply. The Association of College and Research Libraries withdrew its quantitative standards in 1995 and now recommends a more qualitative approach responsive to each campus' unique context.

The following table summarizes the assumptions behind the space estimates. The projected figures for 2020 are estimated assuming a total target growth over ten years of approximately 3,000 students (combined undergraduate and graduate). This same growth rate of 13.5% over Fall 2009 FTE population was then applied to the faculty, assuming additional faculty will be needed to serve the additional students and a similar student:faculty ratio. This lead to a total estimated user population for the libraries of approximately 29,000, compared with 23,500 today.

### LIBRARY SERVICE POPULATION PROJECTIONS

HEADCOUNT ENROLLMENT By College/School (1):	Existing Fall 2009				% of Total Popul'n
	UGrad	Grad	Faculty Total (2)	Totals	
Coll of Humanities & Fine Arts	2,363	700	329	3,392	12.4%
Coll of Social & Behavioral Sciences	4,541	586	208	5,335	19.5%
School of Education	0	836	82	918	3.4%
Isenberg School of Management	3,051	951	121	4,123	15.0%
Other	3,870	684	102	4,656	17.0%
<b>Subtotal</b>	<b>13,825</b>	<b>3,757</b>	<b>842</b>	<b>18,424</b>	<b>67.2%</b>
Coll of Engineering	1,200	380	104	1,684	6.1%
Coll of Natural Sciences & Mathematics	2,184	738	441	3,363	12.3%
Natural Resources Conservation	1,653	336	24	2,013	7.3%
School of Nursing	510	119	50	679	2.5%
Schl of Public Health & Health Sci.	742	429	66	1,237	4.5%
<b>Subtotal - Science &amp; Engin.</b>	<b>6,289</b>	<b>2,002</b>	<b>685</b>	<b>8,976</b>	<b>32.8%</b>
<b>Total Headcounts:</b>	<b>20,114</b>	<b>5,759</b>	<b>1,527</b>	<b>27,400</b>	100.0%
<b>Total Undergrad + Grad only:</b>	<b>25,873</b>				

(1) Data provided by Office of Institutional Research.

(2) Data source for faculty breakdown by College/School: listing of "All Faculty by Department - Fall 2008" provided to Facilities for Academic Space Master Plan study.

# PROJECTED USER SEATING NEEDS IN 2020

Two methods were used to estimate user seating. One was the guidelines of the Council of Educational Facility Planners International (CEFPI) which recommend providing library seating to accommodate 12% of undergraduate students, 30% of graduate students and 5% of faculty, and generated an estimate of 3,800 seats (or about 13% of the overall library population).

Today, Du Bois and ISEL together provide 2,233 seats, serving about 9.5% of the library population. If this were increased to 10% as part of a "right-sized" scenario, then an additional 114 seats would be required, for a total of 2,347 seats. If the 10% were applied to the future population, then a total of approximately 2,900 seats would be needed, or 665 additional seats over today, or a 30% increase. By comparison the Learning Commons today has 312 seats, so it would be the equivalent of adding two additional Learning Commons. The insight from this is that removal of study seating and their replacement with other functions should be evaluated carefully.

	Existing Fall 2009				Right Sized	Projected 2020			
	UGrad	Grad	FTE Faculty	Totals		UGrad	Grad & CPE	Faculty Total	Totals
<b>FTE Enrollments</b>	19,340	2,510	1,226	<b>23,076</b>		21,949	3,292	3,737	
Continuing & Professional Edn (CPE)		391							
<b>Total populations projected:</b>	<b>19,340</b>	<b>2,901</b>	<b>1,226</b>	<b>23,467</b>	<b>23,467</b>	<b>21,949</b>	<b>3,292</b>	<b>3,737</b>	<b>28,980</b>
<b>Percentage of population</b>	82.4%	12.4%	5.2%	100.0%					
<b>Total Undergrad + Grad only:</b>	<b>22,241</b>					<b>25,241</b>			
<b>Percentage of UG+Grad total:</b>	87.0%	13.0%							
<b>Additional students in 10 yrs Growth assumptions (2):</b>							<b>3,000</b>		
							13.5%		

**Notes:**

1. Data source for student enrollment: "Fall Enrollment Fact Sheet, Fall 2009 - Full-Time Equivalent (FTE) Student Majors," from Office of Institutional Research, Oct. 19, 2009. Faculty total from "UMass At a Glance 2009-2010".
2. For projections, this reflects the assumption that UMass will grow by 300 students/year for 10 years, for an additional 3,000 students (undergrad and grad) anticipated by 2020, or approx. 12% growth. This table assumes a similar growth rate will apply to faculty to support that growth.

**CEFPI method for estimating study seats:**

CEFPI guidelines for "study" seats on residential campus based on percentage of population:		12%	30%	5%	
Total projected seats:		2,634	988	187	<b>3,808</b>
Percentage of total population:					13%
Est'd projected area at 35 sf/seat:					<b>133,293</b>

**Assuming Projected Study Seats at 10% of Population:**

	Existing	DuBois:	ISEL:		
Actual vs. target percentage of population to be seated at 10%			9.5%	10%	10%
Actual vs. projected seats		1,973	260	<b>2,233</b>	<b>2,347</b> seats
Projected total areas at 35 sf/seat					<b>82,135</b> sf
Additional seats needed (3):					<b>114</b>
Percentage increase in study seating needed					5%
					30%

3. For comparison, the Learning Commons now has 312 seats. Projected total seats for 2010 would involve adding the equivalent of over 2 times as many study seats, in the libraries or elsewhere.

# PROJECTED USER FACILITY NEEDS

Libraries are becoming vibrant centers for learning on campus, not only with study space and support services for learning and research, but also with teaching spaces, coordinated services to support teaching and learning, and with more collaborative study zones to enable effective group work. The UMA Library has created an exemplary facility with the Learning Commons; the master plan proposes building on that success. One intent is to increase the proportion of space devoted to user seating and the other is to shift to more collaborative seating.

**COLLABORATIVE SEATING:** In its 419 open seats, the Learning Commons has a wide range of types available to users, from individual table seats and workstations, to collaborative workstations for 2 or more, open clusters for a group of 6 people around a shared screen and enclosed group rooms from 3 to 6 people capacity. Many students come to the Commons for individual work, finding comfort in “working alone, together.” These are all in great demand (waiting lines are frequent) and with expansion of the student body, even more seats will be needed in the 24 hour zone.

**QUIET SEATING:** Moving further up into the tower, seating zones get progressively quieter. The stack floors have perimeter quiet table and open carrel seating which should be retained with updated furnishings. Other quiet work areas should be located in various areas of the tower.

**MEDIA WORK AREAS:** Today there are about 40 multimedia workstations in the Learning Commons, but more will be needed to meet future demand for media authoring with digital resources and research over the next decade. A central location that users can identify for media facilities and support would be desirable.

**GRADUATE STUDY AREAS:** Graduate students do not have any facilities within the library specifically developed to meet their needs. The enclosed carrels are not pleasant work spaces and often function as storage space.

**SPILL-OUT INFORMAL STUDY AREAS:** Study spaces associated with teaching areas can extend the learning experience by allowing conversations before and after formal class time.

**RESEARCH COLLABORATION AREAS:** Researchers need to be able to work in consultation with librarians and others on new aspects of scholarly communications, subject area resources, and data intensive research. The following page outlines some of the needs for a Research Commons.

For more descriptions of user needs that were expressed and documented in the workshops and focus groups, see the appendix.

The proposed distribution of projected seating capacities with the master plan is broken down by floor on the Stacking Analysis table in section 7 on page 7.17.



# PROJECTED USER FACILITY NEEDS

## A RESEARCH COMMONS

UMass Amherst's need for a Research Commons is being generated by many forces:

- **Research teams are becoming distributed, interdisciplinary, and global**
- **Librarians are functioning more in partnership with faculty and researchers**, as information specialists both working in teams and responding to just-in-time needs
- **Data curation and preservation** are huge university-wide challenges with the exponential growth in research data and grant funded mandates for making data accessible to others
- **University research for curation now includes graduate students' work** as well as faculty research
- **There is need to make data more visible** as well as the people who are doing the research, to stimulate innovation opportunities
- **Life long learning is becoming imperative**, to stay abreast of new knowledge
- **Need for spaces to work collaboratively** with and experience complex data
- **GIS and statistical systems** are becoming complex, and users need assistance in working with them

### SPACE IMPLICATIONS

- **Services implications:** increased staffing with new skills as translators between disciplinary knowledge and information science, in a consultation hub
- **A destination that adds value by connecting researchers** with collaborative space, workshops and colloquia with video streaming
- **Data services support center**, with support for GIS and statistical analysis, data curation, copyright and IP issues
- **More mobile library services**, providing consultations at distributed touchdown spaces in neighborhoods
- **Moving to more active learning experiences and team based learning will increase demand** on informal learning space, library facilities and services
- **Reservable meetings spaces**, for STEM students from multiple disciplines doing team-based learning to connect
- **Facilities available extended hours**, because scheduling can make it difficult for graduate students to get together
- **A place to take a break and reflect**, which all populations need



## 5.3

# PRINT COLLECTIONS PROGRAMMATIC NEEDS

The process of projecting the future collections in 2020 and their space needs was done in collaboration with the library. First an estimate of the existing collections was compiled by collection type, translated into linear footage of shelving. Takeoffs of the actual linear footage in the Du Bois and ISEL stacks were used, as there are slight variations from floor to floor. Then assumptions were developed for potential acquisition rates for various parts of the print collections for the next ten years. The tables on the following pages have those assumptions summarized in the notes column and display the projected linear footage estimated for each collection type. The tables also show what portions of each type might be shifted to off-campus storage when available.

As a major academic research library serving the region, the UMass Amherst Library has retrospective responsibilities. A key question is whether reliable digital archival sources will be available in the future, given the fundamental changes in publishing, scholarship and research. Balancing the cost of storing print materials against the soaring costs of investment in digital resources will continue to be a key challenge for the Library and will influence long term storage decisions.

The library stacks are at capacity, so for a “right-sized” program, the future projections for 10 years out should be used (traditional library planning horizons used to be 20 yrs).

Because open library shelving is considered operationally full at 80%, the estimates also assume an 80% working capacity factor.

**MONOGRAPHS** will continue to be the primary on-campus component of the collections, as their value for browsing is high, especially for the humanities.

**BOUND JOURNALS**, by comparison, are more easily browsed electronically and users are likely to focus in to retrieve particular articles—making them good candidates for off-campus storage. These used to be photocopied by users but now can be received by document delivery services straight from off-campus storage facilities.

**GROWTH RATE TRENDS** are likely to continue: with the proportion of journals acquired in digital form continuing to increase rapidly over the next decade. Acquisition of monographs in print form will lessen but at a slower rate than journals, so modest increase is still predicted. These growth rate assumptions are indicated on the tables. **Even with the projected growth over 10 years, it may be feasible to relocate approximately 30% of the stacks in Du Bois tower either to compact shelving or off-campus storage, freeing up usable space.**

In the following chapter 6, the space implications and strategies for accommodating the collections are outlined..

# GENERAL COLLECTIONS SHELVING PROJECTIONS

	Existing Collections 2010				Projected Collections 2020 (10 years)				Notes (red=to be reviewed)	
	Monographs Volumes	Journals Volumes	Other Volumes	Total Volumes	Linear Feet of Shelving	Projected Volumes - High Scenario	Total Proj. LF - high	Linear Feet on Campus - high		Linear Feet Offsite - high
<b>GENERAL COLLECTIONS</b>										
<b>General Collections Stacks</b>										
Monographs	1,470,489			1,470,489	na	1,690,489	95,800	76,640	19,160	Monographs and journals are shelved together. Assumes .68"/book per UMass collection samples. Assumes 20% of existing monographs collection can be stored off campus.
Journals		608,372		608,372	na	682,372	78,480	51,020	27,460	Assumes 1.38"/BJ per UMass collection samples. Assumes 35% of existing journals can be located off campus.
Music Collection	7,093				402		500	500	0	3rd floor monuments. Reference materials, scores. Tight on space so not browsable. Requires a lot of staff involvement. Assumes 10% growth every 10 years.
Government Docs	494,557	200,000		694,557	10,578	694,657	10,584	6	10,600	About 66-75% of current 6th floor. GovDocs print collection is not growing. Projection assumes 100 vol to be retained in DuBois and rest of Government Docs to go to off campus storage if such space was available
<i>Subtotal - General Collections in Du Bois Tower</i>	1,972,139	808,372		2,773,418	225,080	3,067,600	185,400	128,200	57,200	Existing linear feet is from "Current Shelving Usage, Dec 2009": Shelves in place on the floor at 75,027 x 3'/shelf = 225,080 LF of shelving in Du Bois tower.
<i>Adjust for 80% working capacity factor</i>							231,800	160,300	57,200	
<i>Percentage of existing Du Bois linear footage in the tower to be retained on campus</i>							103%	71%		
<b>Du Bois Basement:</b>										
Gen Coll. stacks	0	0	0	0	0					
Microforms (basement)			1,995,516		886 sq.ft				886 sq.ft.	200+ cabinets. Microfiche, microfilm, audiocassettes
Government Docs microfiche			591,629		100 sq.ft.			0	100 sq.ft.	Government Docs microfiche to go into offsite storage, not growing.
Image Collection			n/a		48 cabinets	0				Slide collections in cabinets. Once all have been digitized, will be returned to Art History Program.

## SPECIAL COLLECTIONS & UNIVERSITY ARCHIVES PROGRAMMATIC NEEDS

Special Collections is currently using shelving on several upper floors of Du Bois, plus the 2<sup>nd</sup> floor of the Goodell Addition for shelving University Archives material. Special Collections has an estimated 14,000 linear feet (LF) of shelving, which are almost full, a small amount in the subbasement of Du Bois, and the University Archives about 7,300 LF, for a total of 21,400 LF

It is anticipated that the collections will continue to grow, especially as some large gift collections are being sought. One large collection was recently obtained. If more of these collections do get donated to the University, it would require a significant amount of staging space to store them while processing, in addition to an allocation of permanent shelving. By 2020 it is estimated that the Special Collections could grow to 25,000 LF and the Archives to 13,000 LF, for a total of 38,000 LF, as summarized on the next page.

Environmental conditions are of particular concern with Special Collections and archival material, so it is recommended that all Special Collections material be relocated into Du Bois stacks once the HVAC systems have been upgraded.

If the shelving on the 2<sup>nd</sup> floor of Goodell Addition is retained for Archives use, then an average 4,000 LF will still be needed for Archives use in Du Bois.

Alternatively, archival material could be stored on the 1<sup>st</sup> floor of Goodell Addition if compact shelving and proper HVAC systems were installed. See section 8 for an analysis of potential capacity there.

Archival material cannot go into off-site storage because of the nature of the boxed documents, the large proportion of documents that may not be cataloged, and how users search through and work with the material.

# SPECIAL COLLECTIONS & UNIVERSITY ARCHIVES SHELVING PROJECTIONS

	Existing Collections 2010				Projected Collections 2020 (10 years)				Notes (red=to be reviewed)	
	Monographs Volumes	Journals Volumes	Other Volumes	Total Volumes	Linear Feet of Shelving	Projected Volumes - High Scenario	Total Proj. LF - high	Linear Feet on Campus - high		Linear Feet Offsite - high
<b>SPECIAL COLLECTIONS &amp; UNIVERSITY ARCHIVES</b>										
Du Bois tower floors										
26th floor					3,054					98% full; SCUA normally adds 200-300 linear ft. per year; could go to 300-500 LF.
25th floor					4,356					98% full
24th floor					2,802					95% full
DuBois Sub-Basement Annex					3,900					50% full as of 3/22/10; expect to be 100% full by 12/10 because of new collection
Subtotal - Spec. Coll in Du Bois					14,112		25,000	25,000	0	Growth as estimated by Spec. Coll.: Low rate at 300 LF/yr plus major gifts; High rate at 500 LF/yr plus major gifts.
Archives Collections - in Goodell					7,300		13,000	9,000	na	85-90% full. Archival boxes (12 x 15 x 18). Assume growth low of 200 LF/yr and high of 300 LF/yr; fixed capacity for Goodell storage. Archival material must be accessible on campus.
Difference in Archival Coll which will not fit in Goodell and must go to Du Bois								4,000		
Subtotal - Total Spec. Coll.					21,412		38,000	34,000	0	

# ISEL COLLECTIONS PROGRAMMATIC NEEDS

The ISEL print collections today consist of approximately 282,000 volumes, of which 186,156 are monographs and 96,724 are bound journals, stored on four floors.

**BOUND JOURNALS:** Around 2002-2003 the library started converting heavily to electronic journals. In a science and engineering library, demand is for the most recent research and data, so journals older than 10 years are used far less frequently. It would be appropriate to store old bound journals in an off-site storage facility, with a document delivery service to scan articles on demand. It is often convenient for users to search for old journal articles online and users tend to identify specific articles to recall, compared with the use of monographs which is more prone to browsing.

Of the ISEL bound journal collection, 70-75% are thought to be pre-2000 and could be put into offsite storage, if that became available. Taking 70% of the existing bound journals could relocate an estimated 67,700 volumes.

The compact shelving recently installed in the basement is estimated to have a capacity of 5,500 linear feet of shelving. However, it will be filled fairly soon with material being relocated from the 3rd floor. The bound journals there may be candidates for relocation offsite, freeing up that compact shelving to store older or less used monographs.

The future growth rate for the ISEL print journals is anticipated to be about 200 volumes per year. Today ISEL carries about 328 titles, which the library anticipates will reduce to 225-250 titles with the current serials review process now underway. To reduce the acquisition rate for print material further, it would require increased budget for acquisition of digital equivalents.

Material on the 3rd floor is a mix of monographs and bound journals (which are only about a third of the material on that floor). The 2nd and 3rd floors currently hold only monographs.

**MONOGRAPHS:** Regarding future growth, it is anticipated that the monographs collection may continue to grow at roughly the same rate for the next 5 years, perhaps starting to show a decrease by 10 years. (The level is small enough that the change in rate does not have much impact on the total collection size though.) The monographs portion of the collection is anticipated to be about 180,000 volumes in 10 years.

The Library is studying what portions of the monographs collection could be placed in offsite storage, but this is more complex to do than with journals. Most pre-1970 monographs can probably be relocated offsite, estimated at about 25,000 volumes.

# SCIENCE & ENGINEERING COLLECTIONS SHELVING PROJECTIONS

	Existing Collections 2010				Projected Collections 2020 (10 years)				Notes (red=to be reviewed)	
	Monographs Volumes	Journals Volumes	Other Volumes	Total Volumes	Linear Feet of Shelving	Projected Volumes - High Scenario	Total Proj. LF - Linear Feet on high	Linear Feet Campus - high		Linear Feet Offsite - high
<b>INTEGRATED SCIENCE AND ENGINEERING LIBRARY COLLECTIONS</b>										
3th floor	73,534	34,724		108,258	19,068					Existing linear footage takeoffs provided by ISEL.
2nd floor	17,958	0		17,958	2,133					
1st floor	94,664	0		94,664	8,169					
Basement	0	62,000		62,000	5,500					
					34,870					
<b>Monographs - ISEL</b>	186,156					204,700				At current rate monographs projected to grow 1850 vol/yr. (For a lower scenario, assume rate drops after 5 yrs: 1850vol/yr for 5 yrs and 900 vol/yr for 5th - 10th yrs. Results tested were minimally different.)
Reduction by shift to offsite storage	-25,067					-25,067	1,500		1,500	Assume pre-1970 monographs can be shifted to offsite storage (appr. 25,067 vol.)
<i>Subtotal projected</i>						179,700				
<b>Total Monographs - adjusted for 80% working capacity</b>						224,625	12,800	8,500	4,300	Assume steady state of 8500 LF collection on site; growth displaces more to storage over time as monographs age.
<b>Journals - ISEL</b>		96,724				98,800				Project to increase bound journals by ~200 vol/yr. Today ISEL carries 328 titles; anticipate reduction to 225-250 titles with current serials review. Assume 125 vol/yr for low scenario assuming budget support for increasing acquisition in digital rather than print form.
Reduction by shift to offsite storage		-67,700				-67,700	7,800		7,800	
<i>Subtotal projected</i>						31,100				
<b>Total Journals - adjusted for 80% working factor</b>						38,900	4,500	4,500		
<b>Subtotal - ISEL Collections</b>				282,880	34,870	303,500	26,600	13,000	13,600	
<i>Percentage of ISEL collections to be retained on campus</i>				vol	LF	vol	LF	37%	LF	ISEL may require only 35% of existing shelving
<b>Off-site: 5 College Depository</b>				250,000	na				70,800	Currently 395,000 vol in the shared facility; now at 80% of original 500,000 design capacity. UMass was allocated 250,000 vol so has used up its share. Shelving is in bins, not on LF of shelving.
<i>Additional volumes projected to be put in off-site storage</i>										



## 5.4 LIBRARY STAFF SPACE NEEDS

In an ongoing process of improvements, the library has been relocating staff groups and upgrading their furnishings over the last year. The consolidation of staff and proximity to the loading dock has improved operational efficiencies. Some of the highlights about staff space issues and recommendations are summarized here, but for a full detailing of assumptions and projections for right-sized and future staff space, see the breakdown in the space program. There is also a description of each workgroup's function, adjacency and space requirements in the appendix.

**INFORMATION RESOURCES MANAGEMENT (IRM)** was relocated down to the Lower Level. This group handles acquisitions, processes all incoming print materials into the library, manages digital resources, and prepares shipments to go to the bindery. Although this group will be one of the most subject to the shift from print to digital resources, through retraining of staff to shift into new roles over the next decade, the total number of staff is not expected to reduce. There may be some efficiencies of layout that could be gained if relocated, but these workstations do need to accommodate book trucks that are integral to the processing function.

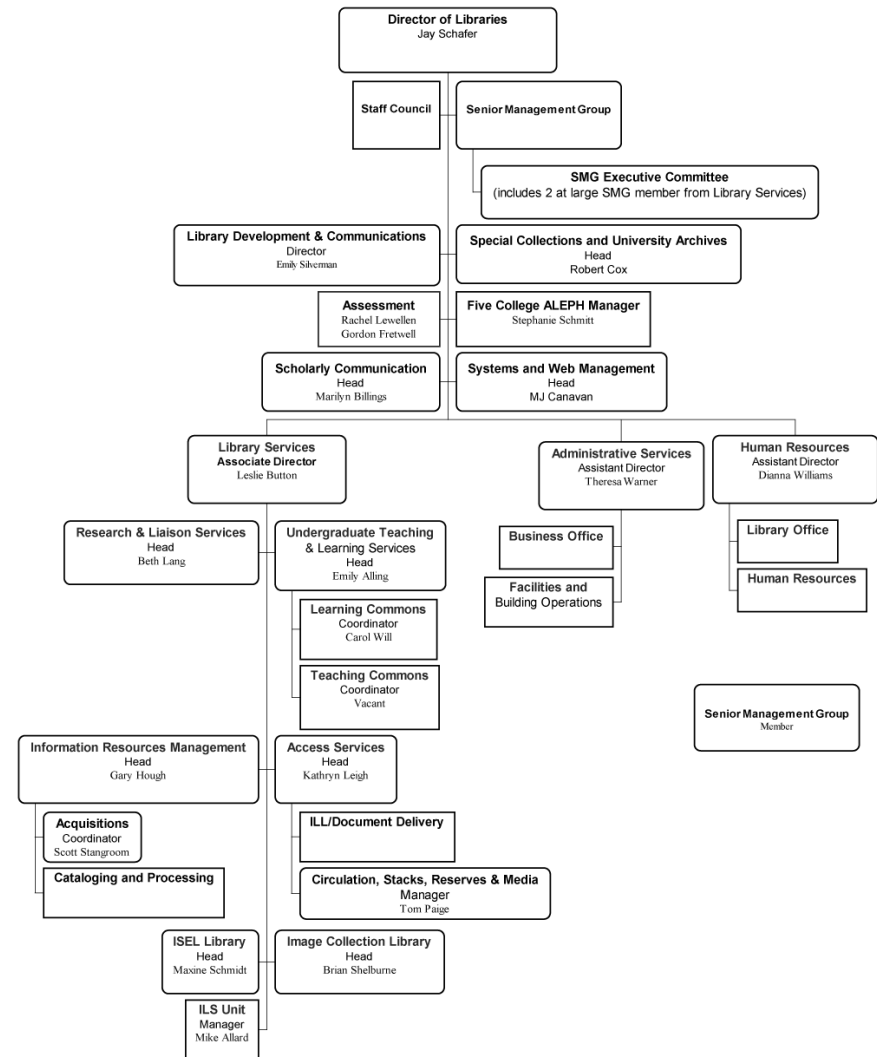



**ACCESS SERVICES** is adjacent, having recently been moved down to the Lower Level from the 1<sup>st</sup> floor. It consists of the service desk (for circulation/reserves/microforms), stacks management sorting areas, Access Services staff workstations, and Interlibrary Loan. The relocation of the main circulation desk to the Lower Level was a bold move acknowledging the active center of gravity that the Learning Commons has become, and freeing up more of the 1<sup>st</sup> floor to user-centered functions. Self-checkout stations at the lobby along with a security/information station will continue to monitor the security gate for circulation of print materials.

Although these functions are accommodated in new quarters in the Lower Level, some areas of the layouts are tight and deficiencies should be addressed over time, potentially with moves that can regain more of the Lower Level for high traffic user seating. Materials handling in these back-of-house work groups requires more space than the typical University standards because of book trucks.

**RESEARCH & LIAISON SERVICES** staff are currently on the Lower Level in a suite near the reference service desk in the Learning Commons. Although convenient to undergraduates, much of the population they serve consists of faculty scholars and researchers, so a more accessible presence in the Research Commons would increase the effectiveness of research/reference services.

**SCHOLARLY COMMUNICATIONS** is a growing area of services within the library, as involvement in digital scholarship increases. Currently located in several rooms on an upper level of Du Bois, this group can become a key component of a new Research Commons.

**LIBRARY ADMINISTRATION & SYSTEMS** staff space primarily needs renovation, with some expansion to address deficiencies. The server room is not anticipated to need significant expansion over time given technology trends to greater capacity in smaller equipment, cloud computing and the like.

**THE IMAGE COLLECTION** Library is a small work group with student assistants to help with the digitization of slides. Once that conversion is completed, there may be more value in relocating that group into Du Bois for greater synergy with other groups in a media center. To offer more media-oriented services in the future, the library plans to develop staff with experience in media, and expand services into digital authoring, GIS and data services, and data curation.

**LEARNING COMMONS** staff are on the Lower Level and are projected to remain relatively stable in terms of space needs.

## 5.5 COMPATIBLE USES SPACE NEEDS

A goal of the Libraries master plan was to explore uses and recommend options that would be compatible with the library's mission if space could be made available.

**CENTRALLY SCHEDULED TEACHING SPACE:** The primary compatible use desired by the Provost's office was more centrally scheduled teaching space to meet pressing demands for more classrooms identified in the 2009 Academic Plan. The Library master plan proposes two new learning studios in the Lower Level, one at 60 seats and the other at 90 seats.

**OIT MANAGED COMPUTER CLASSROOMS:** The Du Bois Library already houses centrally scheduled computer classrooms managed by OIT on several floors. The plan proposes retaining the same number of classrooms but relocating and consolidating them with an improved layout.

**LIBRARY CLASSROOMS:** The other classrooms managed by the Library are scheduled by the Library on a varying schedule determined by the Library's teaching programs. The plan proposes the same number of rooms but right-sizing them.

**DEMONSTRATION TEACHING SPACE:** There is need for a classroom for about 126 students, especially an experimental one (referred to as the Learning Lab) that can be used for teaching development programs and booked on demand for short periods for faculty experimentation.

**LEARNING RESOURCES CENTER:** This existing facility within the library is very popular and in the future will need to expand peer tutoring seating and counseling areas to serve the growing student population in the future.

**TEACHING COMMONS AND TEACHING DEVELOPMENT CENTER:** The Teaching Commons has recently opened this year in Du Bois. The plan proposes to integrate offices for staff responsible for the Commons, which will help energize activity there and allow staff to work more effectively with library staff supporting teaching.

**OTHER EXISTING COMPATIBLE USES:** The Du Bois Center (former Horace Mann Center) and the UMass Press Storage remain uses compatible with the library mission.

**RESEARCH & ENGAGEMENT OFFICES:** The offices for Research & Engagement will be a very compatible use, supporting research endeavors and researchers as they pursue and manage grant funded research projects. Co-location with library research services will enable a one-stop center to support researchers. The workspace needs of this group are outlined in more detail on the following page.

Other functions were also considered, including the Deans' offices with expanded advising functions, but were deemed not feasible.

For a summary of the compatible uses included, see p. 5.21.

# RESEARCH & ENGAGEMENT OFFICES

## COMPATIBLE USES SPACE NEEDS

### SPACE NEEDS

Currently the Research & Engagement (R&E) offices are located in a facility that is too constrained and the group needs to expand to serve the growth of the research sector at UMass Amherst. Existing groups within R&E compatible with library functions\* consist of:

Commercial Ventures & IP	1,088 nsf
Grant & Contract Administration	2,987 nsf
Research Affairs	2,036 nsf
Research Liaison & Development	519 nsf
<b>Total Existing</b>	<b>6,630 nsf</b>

Research & Engagement services are compatible with the Library's research services and co-location will provide added value to users, greater convenience of access and opportunities to co-develop new services with the library.

It is desirable to accommodate the full R&E group together if possible. However, Commercial Ventures & Intellectual property (CVIP) would benefit from being near to its primary client base, the research scientists in the Science and Engineering precinct.

R&E growth is estimated at about a 20% growth factor, so space estimates reflected this.

(\* Groups not included were animal care staff located in multiple other facilities.)

### LOCATION AND ADJACENCY ISSUES

A primary benefit of locating R&E in the Du Bois tower associated with the new Research Commons, is the potential for synergy of services with the library and sharing collaborative workspaces and meeting rooms for consultations. In particular, R&E needs a "War Room" for intensive grant preparation periods and would like to develop a high end meeting space enabled with AccessGrid technology. The proposed facilities are described under section 6 on Program Concepts (page 6.10-12.)

As an alternative location, some or all of the R&E group could also be accommodated in the top floor of ISEL, associated with the library consultative services and a renovated commons there. Various options were tested and will be described in later sections. As that floor is also being considered for Chemistry in the future, further resolution will be needed as part of the next phase of the planning process.

# SUMMARY OF PROPOSED COMPATIBLE USES

This table summarizes existing and proposed compatible uses in the recommended master plan.

In some areas, like the Learning Commons, library functions and compatible uses are blended, so hard to break out—a statement about the effectiveness of their integration.

The total increase in compatible uses is estimated at another 24,600 nsf in addition to the existing 37,650 nsf, or an increase of 65% over existing space allocated to compatible uses.

	Existing Area nsf	Proposed 2020 usf	Percent Increase	Current location level	Proposed location level
<b>TEACHING SPACE</b>					
<b>Centrally scheduled teaching spaces</b>					
Calipari Room	1,084	1,084		LL	LL
New Learning Studio (in design)	2,079	2,079		LL	LL
2nd Learning Commons Learning Studio	0	2,700			LL
<b>OIT</b>					
OIT Classrooms	4,010	7,190		7	4
OIT Staff	1,195	1,140		7	4
	<b>8,368</b>	<b>14,193</b>	<b>170%</b>		
<b>LEARNING SPACE</b>					
<b>Learning Resource Center</b>					
LRC Classrooms	4,358	6,550		13	7
LRC Staff space	768	2,130		13	7
Learning Lab	0	3,276			2
	<b>5,126</b>	<b>11,956</b>	<b>233%</b>		
<b>LIBRARY/PARTNERS SERVICES</b>					
<b>Learning Commons</b>					
Learning Commons staff space	715	715		LL	LL
Advising desk	200	200		LL	LL
Learning Commons Writing Center	1,080	1,300		LL	LL
<b>Teaching Commons</b>					
Teaching Development Center staff	1,947	2,680		26	22
<b>Research Commons</b>					
Visualization Rooms (Du Bois & ISEL)	0	1,000			20, ISEL 3
Incubator workspace	0	1,980			21
Du Bois Center (Horace Mann Bond Center)	1,327	776		22	25
UMass Press Storage	827	827		B	B
	<b>8,532</b>	<b>11,938</b>	<b>140%</b>		
<b>Research and Engagement Offices</b>					
CVIP	1,200	1,872			ISEL 3
Grant & Contract Admin/ Reseach Affairs	4,708	7,360			19
War Rooms (Du Bois & ISEL)	0	1,120			19, ISEL 3
	<b>5,908</b>	<b>10,352</b>	<b>175%</b>		
<b>COMMONS SPACES</b>					
Café (Du Bois)	672	1,905		1	1
Café (ISEL)	0	300			
Colloquium Space	0	2,700			26
Central Comp/telecom service	4,251	4,600		B	B
Building support	4,795	4,800		B	B
	<b>9,718</b>	<b>14,305</b>	<b>147%</b>		
<b>Total Estimated Compatible Uses</b>	<b>37,652</b>	<b>62,744</b>			
<b>Additional over Existing:</b>	<b>25,092</b>		<b>167%</b>		

## 5.6

# LEARNING SPACE NEEDS: THE LEARNING LANDSCAPE CONTEXT AT UMASS

Parallel with the Library master planning process, DEGW conducted a study of the Learning Landscape at UMass Amherst and the implications for future learning space needs. The Learning Landscape perspective for planning includes the full spectrum of places that learners experience—both formal and informal, physical and virtual—and views campuses holistically from the learners' perspective. This study started with review of the Academic Plan report and its analysis of classroom space across campus. DEGW then conducted workshops with faculty, staff and academic leadership to explore potential directions for future pedagogy and improvements to the learning experience. This was complemented by interviews and space observations of existing learning space.

The findings defined primary issues to be addressed for the Learning Landscape at UMass, through space, technology, and services/support as well as new ways of using them. A new vision was articulated, of more active, collaborative and project-based learning happening in a network of well-supported spaces across campus.

Major changes are underway that are leading to new pressures for space. Changing the General Education courses from 3 to 4 credit hours will be addressed by introducing more blended or hybrid course delivery with online components.

Some of the implications for the library from the study were:

- **More virtual learning activities will require the Library to provide support services in virtual arenas.**
- **The trend to more team based work will encourage more interaction outside of class, much of which is likely to gravitate to the Learning Commons and other library facilities** as learners seek collaborative venues to work.
- As disciplines become more interdisciplinary in their teaching and research, **interdisciplinary teams of students will need to seek out places to work together enabled by technology outside of scheduled class time, especially in the STEM fields.**
- With blended courses, in the future students may have the choice to attend classes virtually, as is already being done at some institutions now, which could change space occupancy loads and shift to a more distributed model. **Some remote virtual class participation may happen from study venues like the library spaces**, especially if students chose to participate synchronously in groups, increasing demand for collaborative study seating.



# KEY FINDINGS

## THE LEARNING LANDSCAPE CONTEXT AT UMASS

### LEARNING EXPERIENCE

- Dependence on large lectures is poor for student interaction and engagement. Need to find ways to enable breakouts, provide flexible learning studios, and enable class participation in multiple ways.
- Changes in General Education credit hour requirements will require increases in blended/online offerings, with implications for development of learning objects, assessment, faculty support, and scheduling
- Learning must also be supported outside of the classroom requiring new kinds of support spaces, technology, and expert guidance
- Space plays an important role in student quality of life, supporting intellectual community and expressing shared values. Vibrant places are needed for blended activities, identity and peer sharing.

### PEDAGOGY

- The University desires to move towards more active learning modalities
- There are limited opportunities for faculty to try out new spaces, technologies, or pedagogies
- The Library is increasingly involved in the educational process, teaching students about use of resources and research process, digital literacy, and responsible scholarship
- Current innovations in pedagogy are often not showcased or scaled-up, no clear way for leading ideas to filter out to others
- It is desirable to manage time in and out of class to capitalize on informal learning opportunities (e.g. online tutorials, peer tutoring, simulations)

### SPACE MANAGEMENT

- Quantity of space seems to always trump quality (achieving seating capacity takes priority over the quality of those seats) limiting opportunities for new teaching methods
- Existing spaces are generally in poor/fair condition and often dictate pedagogy in their furnishings and support
- “Space Issues” are also really “Time Issues” relating to how space is scheduled/allocated, lowering attendance and inhibiting innovation
- Large lecture halls need to be taken offline for renovation. Need for replacement venues for large sections.

# IMPLICATIONS FOR THE LIBRARY MASTER PLAN

## THE LEARNING LANDSCAPE AT UMASS

### AREAS OF FOCUS

- Support interdisciplinary work
- Support creating with media
- Encourage research initiatives and undergraduate involvement in research
- Create a culture of and system for assessment for learning outcomes
- Increase interdisciplinary activity through the location of elements that can be shared across departments as well as through incentive and support structures
- Develop course work to be globally oriented but locally engaged to encourage research initiatives and retention
- Develop and support hybrid courses that are a blend of physical and virtual activities, requiring spaces that integrate technology, remote participants, and face-to-face interaction

### ACTIVITIES & SUPPORT

- Provide support for a full spectrum of learning activities, from formal teaching to informal peer learning
- Manage time in an out of class to capitalize on informal learning opportunities (e.g.: online tutorials, simulations, group meetings, projects etc) and make the most of time together in class for interaction
- Provide a common fabric of support to address shared needs (e.g: media development), providing support and coordination beyond the level of the course/instructor with a distributed service model (help comes to you and you go to it)

### LEARNING SPACE

- Develop a network of places to encourage a flow of activity and create synergies between different functions and groups
- Enable multiple teaching modes and devote more class time to interactive activities (i.e. lab time or increased discussion time)
- Make classroom availability more accessible and transparent, and allocation more flexible to enable some booking by the session rather than for whole semester
- Enable large classrooms to have the feeling/atmosphere of an intimate seminar – through new construction/renovation of space as well new ways of using these spaces

# PLANNING PRINCIPLES

## THE LEARNING LANDSCAPE AT UMASS

*These principles, drawn from engagement with faculty, students, and leadership and informed by trends happening elsewhere, describe the kind of learning experience that are desirable for UMass students and can be used to guide decisions about learning spaces for the future.*

### EXPERIENCE:

- Promote student-to-student and student-to-faculty interaction by optimizing class meetings, more collaboration, work made visible (in and out of classroom)
- Incorporate research experience as a part of the learning experience, including for undergrads
- Facilitate ubiquitous access to information resources and navigation through it, leveraging campus experts (e.g.: Library and OIT)
- Assess learning outcome to align space, pedagogy, and support and use research to understand and anticipate demand

### PEDAGOGY

- Engage students in real-world, authentic problems to provide them with opportunities to collaborate and gain experience in addressing important future issues
- Support collaboration at multiple scales – 1:1, small group, whole class and beyond (physically & virtually)
- Share and showcase successes on campus and scale them up incrementally and in strategic locations

### SPACE / SPACE MANAGEMENT

- Enable multiple modes of learning & teaching with reconfigurable spaces and support. The future learning experience will require moving fluidly between different kinds of activities, in and out of the classroom
- Provide a variety of settings in the Learning Landscape to enable different activities and support different styles of teaching/learning
- Enable experimentation within existing and renewed spaces by lowering the barrier to entry with help for faculty in transition and ongoing support (e.g.: bookable spaces to experiment during one class meeting)
- Consider up front costs for space and technology but also operational costs for faculty/support staff

# UMASS AMHERST LEARNING LANDSCAPE MAP

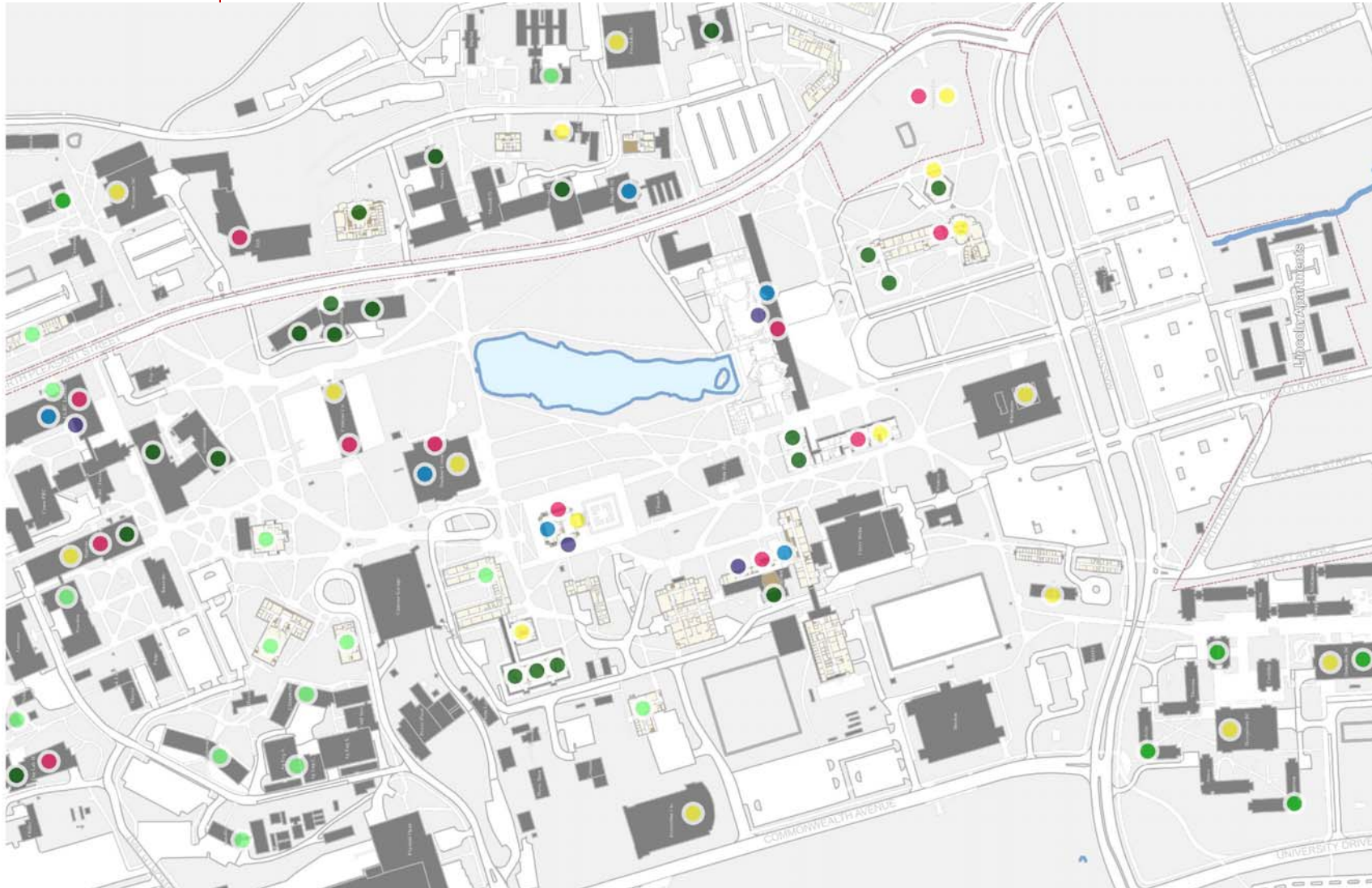

- FOOD
- COLLABORATIVE WORK & INFORMAL LEARNING
- LIBRARY FACILITIES
- COMPUTING SPACES
- GENERAL USE/RESIDENTIAL TEACHING SPACE
- AUDITORIUM TEACHING SPACE



# SUMMARY OF PROPOSED PROGRAM

	Breakdown - Existing				Right Sized Program		Proposed Program 2020	Change to Existing	Breakdown - Proposed 2020		
	Existing Area 2010	Library Space	Library Stacks	Compatible Uses	2010 (usf)	Difference			Library Space	Library Stacks	Compatible Uses
<b>1.0 Public Spaces</b>											
1.1 Lobby Zone	972	972			2,265	1,293	3,225	332%	1,265		1,960
1.2 Meeting Rooms	1,995	1,995			2,025	30	4,810	241%	4,810		
1.3 Library Teaching Spaces	2,723	2,723			3,360	637	6,640	244%	6,640		
	<b>5,690</b>				<b>7,650</b>	<b>1,960</b>	<b>14,675</b>	<b>258%</b>			
<b>2 Learning Commons</b>											
2.1 Learning Commons Service Desks	2,020	2,020			2,200		2,670		2,670		
2.2 Learning Commons Teaching Spaces	3,183				3,190	7	5,890	185%			5,890
2.3 Learning Commons User Seating	15,025	15,025			19,510	4,485	24,500	163%	24,500		
2.4 LC Staff and Reference/Research & Liaison Offices	4,392	4,392			3,260	-1,132	1,030	23%	1,030		
	<b>24,620</b>				<b>28,160</b>	<b>3,540</b>	<b>34,090</b>	<b>138%</b>			
<b>3 Library Staff Offices</b>											
3.1 Access Services	7,322	7,322			7,640	318	7,640	104%	7,640		
3.2 Library Administration	8,054	8,054			6,340	-1,714	6,650	83%	6,650		
3.3 Information Resources Management	8,340	8,340			7,330	-1,010	6,980	84%	6,980		
3.4 Integrated Library Systems Unit (ILS)	400	400			780	380	780	195%	780		
3.5 Administrative Support Space	0	0			2,380	2,380	1,370		1,370		
	<b>24,116</b>				<b>24,470</b>	<b>354</b>	<b>23,420</b>	<b>97%</b>			
<b>4 Print Collections</b>											
4.1 General Collections	86,279		86,279		91,800	5,521	91,800	106%		91,800	
4.2 Maps Collection	2,270		2,270		2,300	31	2,500	110%		2,500	
4.3 Media & Reserves	2,704		2,704		0	-2,704	0	0%		0	
4.4 Music Collection	na		0		280		280			280	
4.5 Microforms	6,281		6,281		6,290	9	6,290	100%		6,290	
4.6 Sub-basement Compact Shelving	0		0		20,440	20,440	20,440				
4.7 Goodell Storage (additional capac.compact shelving)	0		0		0	0	0				
4.8 Image Collection	na		0		0		0				
	<b>97,534</b>				<b>121,110</b>	<b>23,577</b>	<b>121,310</b>	<b>124%</b>			
<b>5 Special Collections</b>											
5.1 SCUA Staff Work Areas	4,679	4,679			2,840	-1,839	3,650	78%	3,650		
5.2 User Spaces	1,224	1,224			1,220	-4	1,580	129%	1,580		
5.3 Special Collections Stacks	8,626		8,626		16,040	7,414	16,040	186%		16,040	
5.4 University Archives in Goodell	7,295		7,295		7,295	0	7,295	100%		7,295	
	<b>21,824</b>				<b>27,395</b>	<b>5,571</b>	<b>28,565</b>	<b>131%</b>			
<b>6 Distributed Study Seating</b>											
6.1 Distributed Quiet Study Seating	35,948	35,948			35,948	0	37,447	104%	37,447		
6.2 Enclosed Carrels	16,274	16,274			16,274	0	0		0		
6.3 Distributed Collaborative Study Seating	393	393			393	0	0		0		
	<b>52,615</b>				<b>52,615</b>	<b>0</b>	<b>37,447</b>	<b>71%</b>			

# SUMMARY OF PROPOSED PROGRAM

	Breakdown - Existing				Right Sized Program 2010 (usf)	Difference	Proposed Program 2020	Change to Existing	Breakdown - Proposed 2020		
	Existing Area 2010	Library Space	Library Stacks	Compatible Uses					Library Space	Library Stacks	Compatible Uses
<b>7 Media Hub</b>											
7.1 Media Hub Staff (incl. Digital Image Coll.)	3,675	3,675			2,570	-1,105	3,320	90%	3,320		
7.2 Media Hub User Stations	2,329	2,329			3,055	726	4,940	212%	4,940		
7.3 Teaching Space	0	0			0	0	480		480		
7.4 Music Reserve Lab	1,183	1,183			0	-1,183	600	51%	600		
	<b>7,187</b>				<b>5,625</b>	<b>-1,562</b>	<b>9,340</b>	<b>130%</b>			
<b>8 Research Commons</b>											
8.1 Consultation/Collaborative Zone	0				0	0	3,020		3,020		
8.2 Research & Scholarly Communications Services	3,106	3,106			1,248	-1,858	3,700	119%	3,700		
8.3 Research Commons Work Areas	0				0	0	1,470		1,470		
8.4 Research & Engagement Offices (Res. Affair, GCAdmin)	4,708			*	0	0	7,920	168%			7,920
8.5 Incubator Space	0				0	0	1,980		1,980		
8.6 Graduate Research hub	0				0	0	4,990		4,990		
	<b>7,814</b>				<b>1,248</b>	<b>-6,566</b>	<b>23,080</b>	<b>295%</b>			
<b>9 Teaching Commons</b>											
9.1 Teaching Commons	2,436			2,436	2,460	24	2,460	101%			2,460
9.2 Teaching Development Center Staff	1,947			*	0	0	3,490	179%			3,490
	<b>4,383</b>				<b>2,460</b>	<b>-1,923</b>	<b>5,950</b>	<b>136%</b>			
<b>10 Compatible Uses</b>											
10.1 OIT Managed Spaces in Tower	5,205			5,205	7,560	2,355	8,330	160%			8,330
10.2 Learning Resources Center	5,126			5,126	7,060	1,934	8,670	169%			8,670
10.5 Other Compatible Uses	2,182			2,182	1,881	-301	1,631	75%			1,631
	<b>12,513</b>				<b>16,501</b>	<b>3,988</b>	<b>18,631</b>	<b>149%</b>			
<b>11 Integrated Science &amp; Engineering Library &amp; Research</b>											
11.1 ISEL Research Commons Public Areas	1,815	1,815			4,610	2,795	10,700	590%	10,700		
11.2 ISEL Staff Workspace	1,281	1,281			1,326	45	1,326	104%	1,326		
11.3 Distributed Study Seating	2,345	2,345			8,866	6,521	8,866	378%	8,866		
11.4 Print Collections	32,104		32,104		14,306	-17,798	8,546	27%		8,546	
11.5 Research & Engagement Offices - CVIP	1,199			*	0	-1,199	3,132	261%			3,132
	<b>38,744</b>				<b>29,108</b>	<b>-9,636</b>	<b>32,570</b>	<b>84%</b>			
<b>12 Other</b>											
12.1 Building Support	21,835			21,835	21,108	-727	21,108	97%			21,835
12.2 Library Storage	36,883	36,883			36,883	0	36,883	100%	16,443		
	<b>58,718</b>				<b>57,991</b>	<b>-727</b>	<b>57,991</b>	<b>99%</b>			
<b>Total - Estimated Space (nsf)</b>	<b>442,040</b>	<b>162,378</b>	<b>145,559</b>	<b>36,784</b>	<b>374,333</b>	<b>-67,707</b>	<b>407,069</b>	<b>92%</b>	<b>168,847</b>	<b>132,751</b>	<b>65,318</b>



# 6

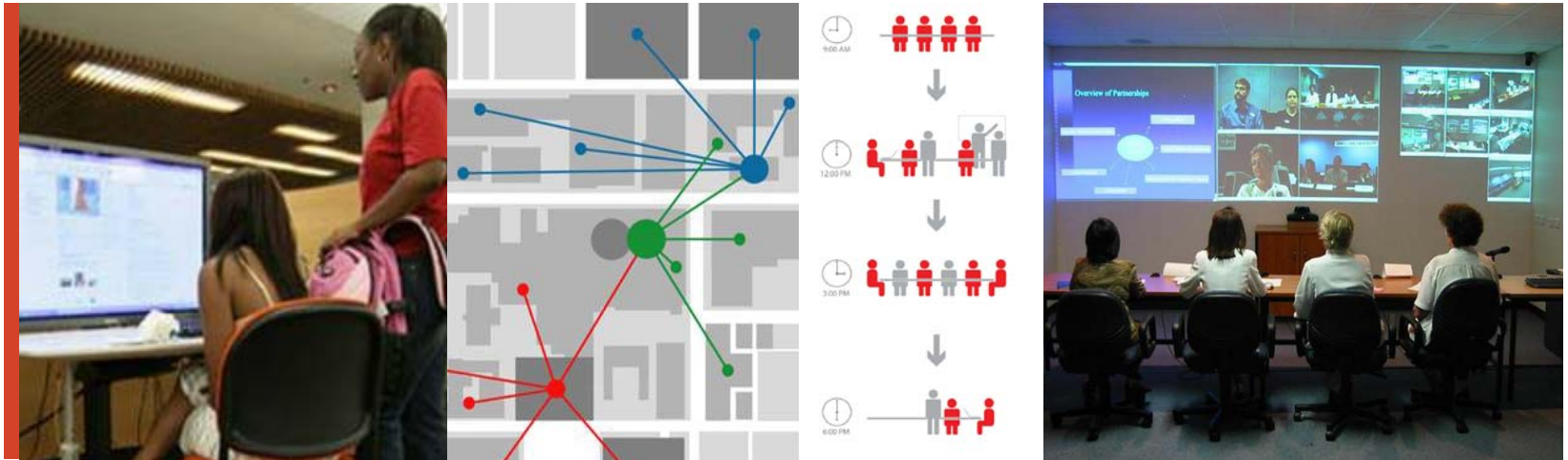

## SPACE STRATEGIES

Collections Strategy

Concepts for New Facilities

Integration of Compatible Uses



## 6 SPACE STRATEGIES

Based on the assessment of programmatic needs, basic strategies were explored for space planning, driven initially by options for accommodation of the future collections.

The strategies also involved identifying compelling concepts for clusters of activities and services that would capture the aspirations of the Library's vision and fulfill the articulated space needs. These activities will complement one another to provide a comprehensive support center for research, learning and scholarship for UMass Amherst.

Initially, the strategies guided the testing of alternative scenarios, followed by workshops in which library space needs were reconciled with other compatible uses' space needs.

Although the preferred strategies were developed into the recommended master plan, the actual execution of these concepts could take a number of paths. The strategies are intended to provide a framework for decision making that will allow flexibility in executing the concepts in response to changing campus pressures and priorities.

The sections in this chapter include:

### **6.1 Collections Accommodation Strategy**

Summary of Collection Location Options

Du Bois Stacks Capacity Analysis

ISEL Stacks Capacity Analysis

Goodell Addition Capacity Analysis

### **6.2 Summary of Concepts for New Facilities**

Research Commons

Science Commons

Graduate Hub

Teaching Commons

Media Hub

Learning Lab

Symposium Center

### **6.3 Strategies for Integrating Compatible Uses**

## 6.1 COLLECTIONS ACCOMMODATION STRATEGY

The stacks in all the libraries are at or above capacity with no room for future growth. The pressures to use on-campus space for many other types of functions, combined with increasing user mobility and ability to access resources electronically from all over campus, suggested a print collections strategy that would allow the libraries to respond to future demands in a flexible way.

- The general collections in the **Du Bois tower** are **proposed to be reduced and then become a steady state collection**, with newer materials displacing older materials
- **Additional storage will be needed, either off-campus or on-campus**, to supplement existing library space and to free up space to be repurposed.
- **Multiple options for on-campus storage are feasible**, some more immediately available than others. These might provide short or long term relief until an expansion to the Five College Depository is feasible.
- **The Depository is almost full** and UMass share is currently “four elevenths” of the capacity. The Consortium is actively studying a plan to enlarge it by adding high density modules next to it. Depending on design this could house up to 2 million volumes. (By comparison the Du Bois tower is estimated to contain 2,773,000 volumes.)
- A significant **reduction in the science & engineering print collections** on-campus will be feasible because of the aggressive migration to digital resources and increasing publication of research datasets in those fields. The higher proportion of journals in those types of collections also make them more easily browsed electronically.
- The **Image Collection is proposed to be consolidated into the Media Hub in Du Bois**. As the task of digitizing the former slide collections of Arts faculty reaches completion, management of the image collection will shift to helping patrons with digital resources, a role which will benefit from a central location on campus.

# SUMMARY OF COLLECTION LOCATION OPTIONS

In order to accommodate the projected growth in the collections, off-site storage capacity will have to be increased. A portion of the existing Du Bois collections could be reallocated into off-site storage if available, removing 20% of monographs, 30% of journals and 100% of the print Government Documents, which would be payable on demand.

Although expansion of the Depository would be the most cost efficient over time, it will require coordinated funding and decision making with an uncertain schedule, whereas on campus options may provide greater flexibility for UMass, at least for the short term.

With additional capacity from this relocation, and with the possibility of on-campus compact shelving in Du Bois basement and/or Goodell, the growth in the General Collections and Special Collections & University Archives could be accommodated despite the repurposing of stack floors in the Du Bois tower.

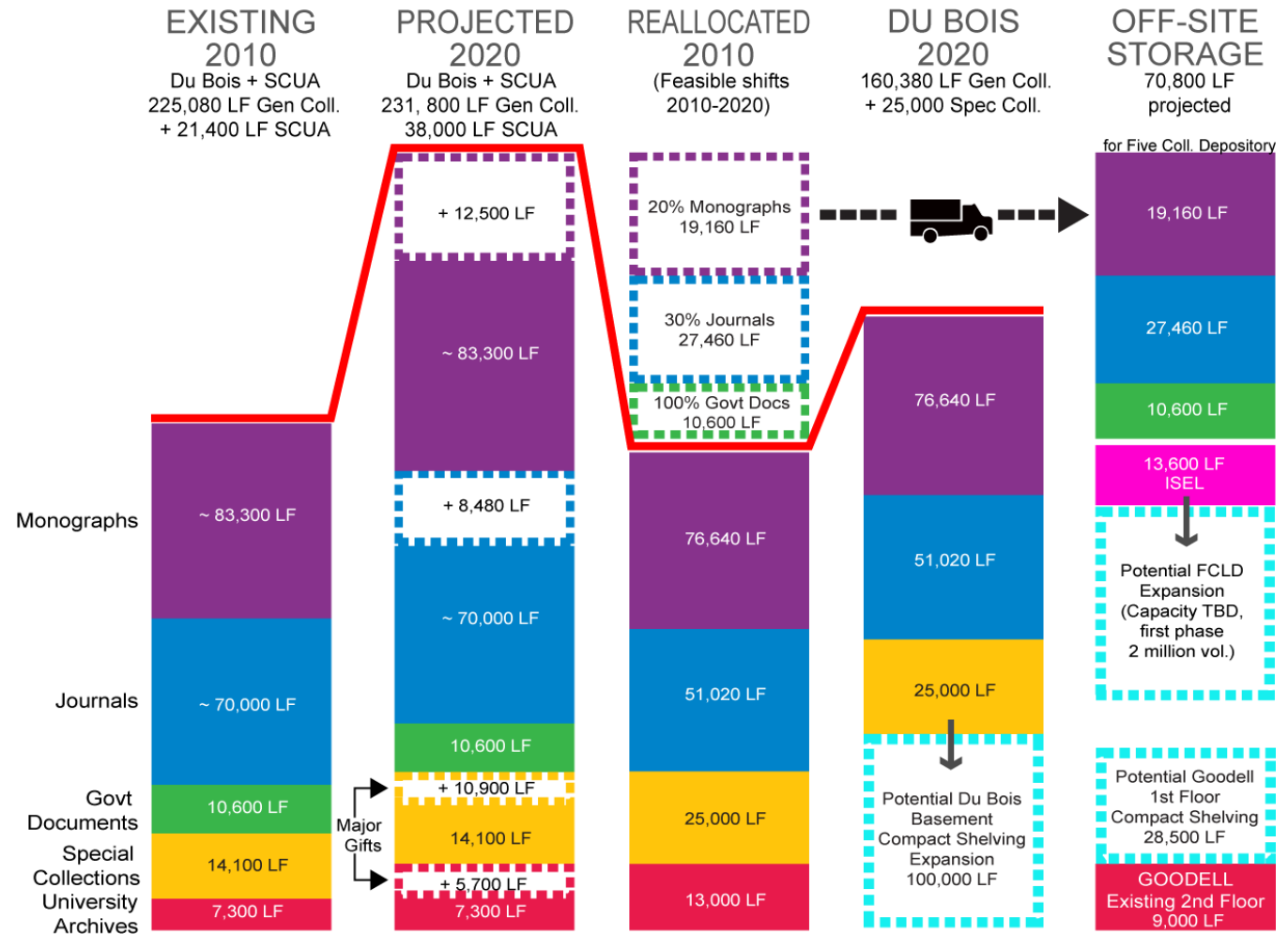

# COLLECTIONS ACCOMMODATION STRATEGY

Some of the issues considered were:

- Although on-campus storage facilities may offer more planning flexibility over the short term, the **fragmentation of the collection will require more staff operation load** on the part of the library to manage and maintain multiple locations.
- **The storage decision has sustainability implications**, with any off-campus storage requiring more regular vehicular use to retrieve materials.
- **If an expansion of the Five College Depository is promoted, operations costs will be shared.** The distribution operation already exists, and there are also efficiencies in consolidated operations.
- **Environmental conditions can be optimized for print collections in closed collection facilities**, rather than compromised for human occupation.
- **Compact shelving will require a significant investment in equipment** that may not be desirable in a temporary facility.
- **The actual sequencing of shifts into storage may become complex** dependent on other decisions, renovations and funding.

With further exploration of what capacity might be feasible in various locations in Goodell, using both compact and regular shelving, and identification of discrete areas in Du Bois basement that could be fitted out incrementally over time, a number of on-campus storage possibilities opened up. Whether these would be entirely closed collections with staff access only, or whether browsing access could be arranged by appointment will have to be studied.

Options studied include the following:

**Du Bois basement**

**Goodell Addition 2<sup>nd</sup> Floor (existing)**

**Goodell Addition 1<sup>st</sup> Floor**

**Goodell upper floors**

**Underground storage facility between Du Bois and Goodell**

**Expansion of Five College Depository**

**New high-density storage facility for UMass only**

**Rented warehouse (for short term)**

Options for additional storage facilities on-campus are described in section 8 on Implementation (see page 8.5).



# DU BOIS STACKS CAPACITY ANALYSIS

Assuming the existing linear footage remains on the stack floors which are being retained in the proposed plan, the tower would accommodate appr. 67% of its existing shelving capacity.

However, if new zones of compact shelving were installed in the basement (in addition to an existing stack block there of 3,900 LF), then Du Bois basement could provide up to an additional 104,000 LF. So even with the tower reductions, Du Bois could accommodate a total of 254,000 LF, an increase over today's capacity. However, less material would be browsable by users but it is anticipated that electronic browsing will continue to become more robust and the material stored in the basement will be less frequently accessed material.

	Floor	Shelves in Place on the Floor (1)	Existing Linear Feet of Shelving	Proposed Scheme 2020	
<b>Du Bois Building</b>	25			SC	
<b>General Collections</b>	24	4,139	12,417	SC	SC =Convert stacks to Special Collections use
	23	6,062	18,186	SC	
	21	5,184	15,552	0	
	20	6,643	19,929	0	
	18	5,727	17,181	8600	
	17	6,254	18,762	18,762	
	15	5,826	17,478	17,478	
	14	6,063	18,189	18,189	
	12	6,238	18,714	18,714	
	11	6,926	20,778	20,778	
	9	2,813	8,439	8,439	
	8	6,022	18,066	18,066	
	6	3,526	10,578	10,578	
	5	3,602	10,806	10,806	
<b>Total - Linear Feet of Shelving DuBois Upper Levels</b>			<b>225,075</b>	<b>150,410</b>	(See replacement capacity to be provided in compact shelving below.)
Percentage of existing capacity:				<b>66.8%</b>	
LF reduction:				74,665	
Reduced by:				33.2%	
<b>DuBois Basement</b>					
Spec Coll storage			<b>3,900</b>	<b>3,900</b>	
Compact shelving				<b>100,000</b>	
<b>Total - Du Bois Linear Footage</b>			<b>228,975</b>	<b>254,310</b>	assuming new compact shelving in basemen.

# ISEL STACKS CAPACITY ANALYSIS

Much of the existing ISEL print collection could be stored in off-site storage. Indeed, portions of the collections are currently being moved into the Five College Depository. The ISEL facility currently has 34,870 LF of shelving.

The proposed master plan proposes retaining 13,000 linear feet of shelving in ISEL to accommodate a core science and engineering print collection on-campus, with the rest to be put in storage either on-campus or off-site. Consortium cooperation offers the advantage of further reductions to stored material in the Depository, for example by eliminating redundant copies, especially in the case of journals.

	Shelves in Place on the Floor Floor	Existing Linear Feet of Shelving (1)	Proposed Scheme 2020	
<b>Science &amp; Engineering Library</b>				
3rd Floor East		2,121		6,363
3rd Floor West		3,927		11,781
3rd Reference Annex		308		924
2nd Floor East		644		1,932
2nd Floor West		67		201
1st Floor East		2,142		6,426
1st Floor West		581		1,743
Basement - New Compact Shelving		0		5,500
<b>Total - ISEL LF</b>			<b>13,000</b>	<b>34,870</b>
<b>Goodell Addition</b>				
Existing 2nd floor Goodell space used by SCUA			<b>9,000</b>	<b>9,000</b>
Additional linear footage from converting 1st floor to compact shelving			<b>28,500</b>	
<b>Total linear feet of potential stack capacity on campus</b>		<b>272,845</b>	<b>304,810</b>	
<b>Summary of Additional Capacity Desirable Offsite:</b>				
			13,600	from ISEL
			57,200	from General Collection
<b>Total additional estimated stack capacity targeted for off-campus</b>			<b>70,800</b>	Into Five College Depository or other location. See Collections Projections table on 5.12 for calculations.

Notes:

(1) From table "Current Shelving Usage and Availability, Dec 2009" provided by UML.

# GOODELL STACKS CAPACITY ANALYSIS

Although the Goodell Addition building currently has storage stacks on the 2<sup>nd</sup> floor, used by Special Collections & University Archives, only the 1<sup>st</sup> floor has the capacity to take compact shelving.

If Goodell is renovated to install compact shelving at the lower level, then potential on-campus capacity will be increased by about 40,000 LF. Estimates assume conservatively that headroom may be limited and assume the compact shelving is only five shelves high.

Planning for the 5-College Depository expansion is already under study, but if it takes longer to resolve than hoped, UMass Libraries will have other alternatives to accommodate the collections.

	Room No	Room area (nsf)	Length of ranges (1)	No of single faced ranges	Linear feet of compact shelving in plan (single faced)	Linear feet of regular shelving in plan (single faced)	Linear feet of compact shelving at various heights		
							5 shelves	6 shelves	7 shelves
<b>GOODELL BUILDING</b>									
<b>Fifth Floor</b>	501/502	2,056							
<b>Fourth Floor</b>	409	2,056	30	44	1,320				7,920
<b>Second Floor</b>	206	7,254				9,000	9,000	9,000	9,000
<b>Goodell Addition</b>									
<b>First Floor</b>	101	9,865							
<b>Goodell Addition</b>									
B1 zone			74	22	1,628		8,140	9,768	11,396
B2 zone			74	22	1,628		8,140	9,768	11,396
B3 zone			55	18	990		4,950	5,940	6,930
							21,230	25,476	29,722
B4 zone			30	22	660		3,300	3,960	4,620
B5 zone			40	20	800		4,000	4,800	5,600
							7,300	8,760	10,220
							<b>28,530</b>	<b>34,236</b>	<b>39,942</b>
<b>Total potential shelving capacity estimated for Goodell (3)</b>							<b>37,530</b>	<b>43,236</b>	<b>56,862</b>

**Notes:**

- (1) Assumes cross aisles of 5'
- (2) Estimate provided by UMA Library.
- (3) Estimated maximum, without working capacity factor deducted.

## 6.2 CONCEPTS FOR NEW FACILITIES

Concepts for new types of facilities were generated that bring together activities in special active hubs to support innovation and learning.

**Research Commons** – a consultation hub for research-related resources, scholarly communications, data curation and services for IP/grant management

**Science Commons** – a variation on the Research Commons tailored to the special needs of science and engineering researchers and learners

**Graduate Hub** – a quiet place to work and to connect with peers

**Teaching Commons** – a central consultation hub to promote new ways of teaching

**Media Hub** – a central place on campus to work with library resources and staff to enhance digital scholarship

**Learning Labs** – experimental teaching spaces to enable new pedagogies with support services



Cisco Telepresence

**Research / Science Commons**



Johns Hopkins

**Graduate Hub**



Steelcase

**Teaching Commons**



Apple Store "Genus Bar"

**Media Hub**



Rotman School of Business

**Colloquium Center**



Stanford

**Learning Labs**



# RESEARCH COMMONS

## CONCEPTS FOR NEW FACILITIES

The Research Commons will be a research hub that draws together consultation services offered by the Library, advising on research related resources, scholarly communications and data curation, together with services offered by Research and Engagement, dealing with grant development, IP and grant management.

The facility will also offer technology-enabled collaborative workspace for working with and visualizing data intensive research findings, and a meeting room equipped for multisite collaboration.

The Research Commons in Du Bois will serve all researchers on campus, but will be a primary location for Library involvement with digital humanities initiatives and innovation in social sciences' use of information systems, complementing the Science Commons being developed in Lederle.

### Research Commons

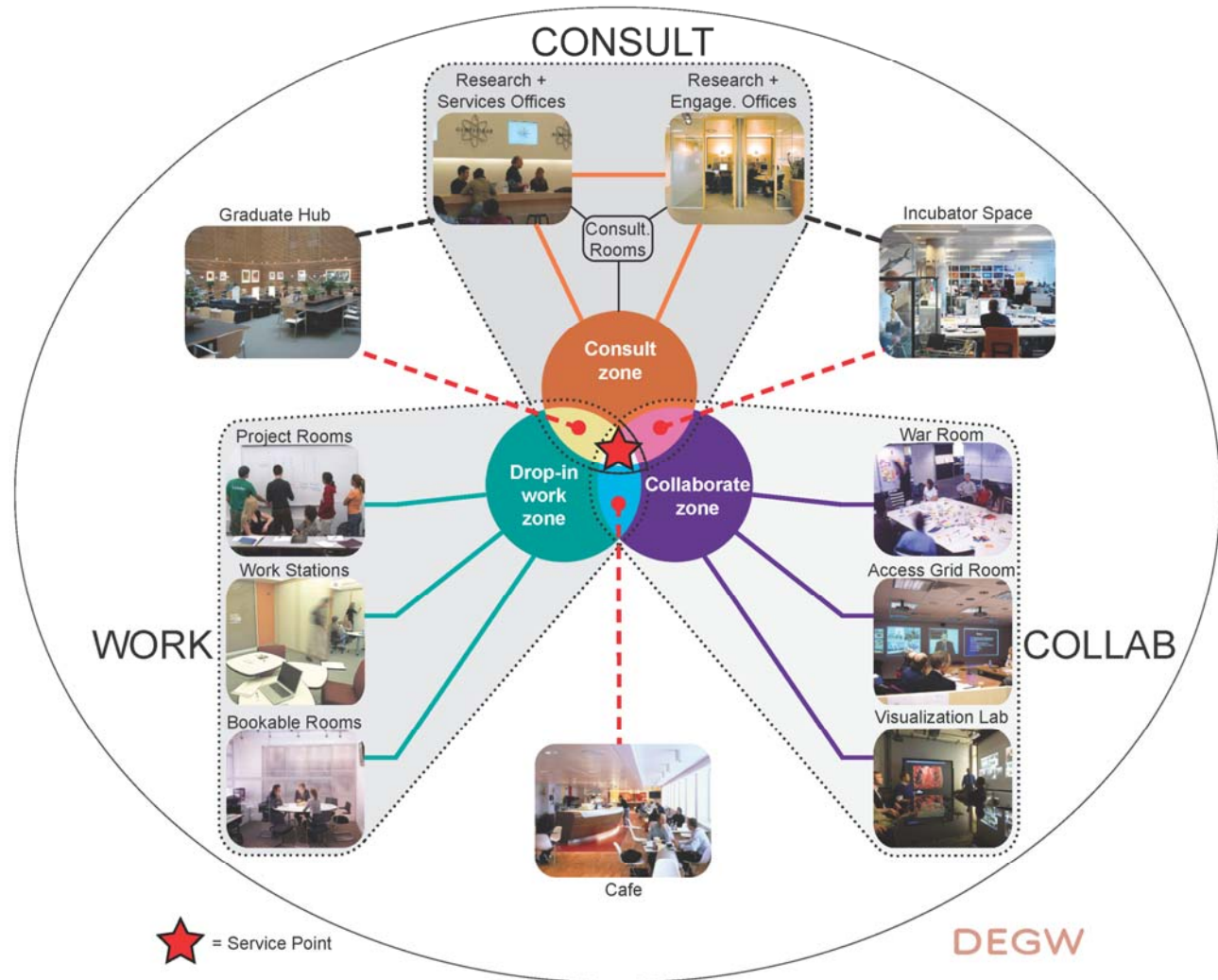

# RESEARCH COMMONS

## CONCEPTS FOR NEW FACILITIES

### SUMMARY

The Research Commons will become a focus for research activity within the library that promotes collaboration between researchers and increases the operational efficiencies of support. The library expertise complements diverse settings to support the full lifecycle of a research project – framing the problem, collecting and working with data, sharing findings, collaborating on solutions, and sharing/ displaying the results. The Research Commons will be adjacent to the Graduate Commons.



### PROGRAM COMPONENTS

- **Welcome zone** with lounge seating & displays
- **Consultation spaces**
- **Scholarly Communications Librarians offices**
- **Research & Liaison Services Librarians offices**
- **Data curation, GIS and statistical related consultation services** drawn from other departments
- **Collaboration areas** with projection surfaces and collaborative software
- **Drop-in and bookable workspace** for researchers including workstations with dual hi rez monitors, small concentration rooms
- **Lockers** for securing personal resources & materials
- **Meeting rooms** with videoconferencing, displays, writable surfaces
- **Visualization Lab** for digital humanities & soc sci
- **Technology consult** and lending point
- **Comfortable, informal seating** and lounge areas
- **Incubator space** for special initiatives, grant-funded projects or post-doc researchers



# SCIENCE COMMONS

## CONCEPTS FOR NEW FACILITIES

### SUMMARY

The ISEL will be transformed into a Science Commons in the heart of the science and engineering precinct. The Commons in Lederle will be a one-stop place for researchers to consult with specialists in e-science research and data services, conveniently located on circulation crossroads. Offering a range of collaborative and individual workspaces accessible for extended hours, it is an interdisciplinary place for connecting with colleagues with the facilitated use of complex data.



### PROGRAM COMPONENTS

- **Integrated service desk**
- **Consultation hub** serving the precinct with small consultation rooms and open workstations for 2-3 people
- **Offices for Science & Engineering librarians**, with specialists in e-science, scholarly communications, data curation, GIS and other data resources
- **Offices for Research & Engagement**, including CVIP
- **Collaborative work areas**, with high resolution monitors and flexible furnishings and café area
- **Group work rooms** in a range of capacities, some with video capture for team presentation practice
- **Drop-in quiet work areas** for concentrated work
- **Visualization room**, equipped for group manipulation of complex data, and connecting with international colleagues using AccessGrid type technology
- **Flexible team-based teaching room** with team displays
- **Electronic gallery displays** along corridor connecting buildings, making research initiatives visible
- **Print collections reduced** to a core collection of monographs plus compact shelving zone in lower level.

# GRADUATE STUDENT HUB: CONCEPTS FOR NEW FACILITIES

## SUMMARY

The Graduate Commons will be a serene place to work and a comfortable setting to meet other graduate students. Featuring a variety of work settings, it will be a place both to concentrate and interact with the rest of the graduate community. It will be located near the Research Commons for access to research services librarians for support. The space will be open to all graduate students, offering bookable workspace and personal storage for research materials.



## PROGRAM COMPONENTS

- **Quiet reading room with open and enclosed workspaces**, bookable and drop-in types, including tables, booths, and carrels
- **Enclosed booths** for concentrated work or phone conversations
- **Comfortable, informal seating** and lounge areas near views
- **Lockers** for personal reference materials and tools
- **Meeting rooms** for brownbag lunches and talks by peers, with displays and writable surfaces
- **Collaboration spaces** with power and projection surfaces / technology
- **Niches and nooks** for students to encamp with materials
- **Coffee vending alcove**
- **Copy/print/scan stations**

# TEACHING COMMONS

## CONCEPTS FOR NEW FACILITIES

### SUMMARY

The Teaching Commons will be a central location on campus for consultation on new ways of teaching. Expanding the existing Commons, it will combine resident expert staff with collaborative workspaces to learn teaching skills and academic technology. It will serve primarily faculty and teaching assistants, providing equipment and tools to stimulate development of digital courses. Proximity to experimental teaching spaces in Du Bois will leverage staff and other synergies of co-location with library resources.



### PROGRAM COMPONENTS

- **Spaces for consultation with expert teams about pedagogy and development of new digital teaching materials**
- **Staff space** for teams of educational services librarians, student assistants, Center for Teaching staff, instructional designers and academic technologists.
- **Open and enclosed workspaces for faculty and staff**
- **Innovative / model classroom(s)** (e.g. learning studios and others with high flexibility and technology integration)
- **Lounge areas** equipped for collaborative work
- **“Practice spaces”** with video recording and playback
- **Media development workstations** with multiple, large monitors and associated peripherals
- **Audio/video editing booths**
- **Demonstration area**
- **Display areas**
- **Copy/print/scan stations**

# MEDIA HUB

## CONCEPTS FOR NEW FACILITIES

### SUMMARY

The Media Hub will be a space designed to support undergraduate and graduate students working with multimedia resources – co-creating, repurposing, producing, listening and viewing them. It will bring together a variety of spaces and the specialized staff support needed for effective media work, with integrated expertise on content, hardware and software. Plentiful collaborative workplaces will support new curriculum initiatives for team-based projects using multimedia.



### PROGRAM COMPONENTS

- **Media production workstations** with multiple, large monitors and associated peripherals
- **Open collaboration areas** with power and projection surfaces / technology
- **Integrated services desk** for consultations and technology support
- **Hardware lending and demonstration area**
- **Staff work areas** (bookable or assigned) with storage
- **Equipment for working with library media collections,**
- **Audio / video editing booths,** possible small video recording studio
- **Enclosed viewing rooms with displays and writable surfaces**
- **Presentation areas** open to passersby for peer feedback
- **Niches and nooks for students to encamp,** tables to spread out and work with project materials
- **Printers and plotters, copy/print/scan stations**



# LEARNING LABS

## CONCEPTS FOR NEW FACILITIES

### SUMMARY

The Learning Labs in the Library will be teaching spaces that are flexible and experimental, responsive to new pedagogical directions (i.e. more team-based and experiential learning). Technology will be well integrated and used in different ways. The presence of both expert and technical staff from the Teaching Commons and Media Hub will enable an integrated support model for faculty to teach in new ways.



### PROGRAM COMPONENTS

- **Innovative / experimental classroom(s)** e.g. learning studios and others with high flexibility and technology integration
- **Flexible furnishings**, with power to each seat
- **High ceilings and multiple projection surfaces**
- **Team screens and whiteboard surfaces** for co-creating team products
- **Sub-dividable** to conduct class sessions of two groups of 60 capacity each or 1 group of 120 capacity
- **Doubles as meeting space** for workshop sessions with up to 60 participants on teaching issues and techniques
- **Located adjacent to informal learning/spill-over space** for break-out sessions
- **Space for storage** of equipment, new teaching tools and mobile furniture

# COLLOQUIUM CENTER

## CONCEPTS FOR NEW FACILITIES

### SUMMARY

The Colloquium Center will be a destination centrally located on campus for functions hosted by the Library and Research & Engagement. Equipped with AccessGrid technology, it will draw up to 150 participants from all disciplines across the campus community at UMass. This space will enable groups to view/work collaboratively and promote cross-disciplinary interaction and research – enabling new partnerships.



### PROGRAM COMPONENTS

- **A large gathering space** with a mix of mobile furnishings to configure based on the event (designed more for flexibility of use than optimized for presentation with fixed seating)
- **Multiple large screens** for display of work
- **AccessGrid technology enabled** to connect and work collaboratively with remote participants
- **Kitchenette** to hosts receptions
- **Displays to showcase research initiatives**
- **Adjacent meeting room for breakout sessions**
- **Ideally a location with great campus views** as a shared facility in the Du Bois tower



# STRATEGIES FOR INTEGRATING COMPATIBLE USES

A range of potential compatible uses were explored, and many have been integrated into the master plan where space could be made available, based on the following rationale:

- **Alignment with the Library's mission and compatibility of functions**
- **Support for learning and teaching excellence**
- **Potential to enhance services for learners, to support them more effectively in out-of-classroom study, research and project activities**
- **Services that will benefit from being located in the only facility on campus open 24/7, and which can provide support into night hours for learners**
- **Groups that will enhance existing services by offering even more integrated and convenient services to users, building on what is currently in the buildings, such as the proposal to locate the Center for Teaching in the Teaching Commons to enhance its effectiveness.**

The compatible uses integrated into the Library master plan include:

- **New centrally scheduled classrooms**
- **Additional library teaching space**
- **Learning Resources Center – expanded teaching and tutoring space**
- **Research and Engagement offices – together with the Research Commons**
- **The Center for Teaching – incorporated into the Teaching Commons**
- **Expanded café and associated collaborative study space**
- **OIT managed teaching and support space**
- **Du Bois Center**
- **Continued use of basement space by non-library functions** (e.g. central comp/telecom, UMass Press storage)

For a full listing of the compatible uses and the areas devoted to non-library uses, see page 5.19 and the summary of the proposed space program at the end of Section 5.



# 7



## MASTER PLAN RECOMMENDATIONS

Du Bois Library  
ISEL Library  
Goodell Building  
Other Library Facilities



## 7 MASTER PLAN OVERVIEW

The master plan for the UMass Amherst Libraries is intended as a framework for development, to guide incremental changes over the next decade to achieve the Libraries' overall vision of services to support scholarship, research and learning in the 21<sup>st</sup> Century, aligned with the University's Framework for Excellence.

The master plan proposes a plan to revitalize the Du Bois building and ISEL utilizing opportunities suggested by the structures themselves and optimizing the program distribution based on the planning strategies and concepts developed during the visioning process. The plan suggests how one third of the print collection now in the Du Bois tower could be relocated into other buildings, accommodating the evolution of new library services, freeing up space at the heart of the campus to serve users of library resources more effectively, and addressing some of the pressing University space needs.

Many compatible uses were explored but those integrated into the master plan are aligned with the Libraries' vision to partner with other campus entities to provide integrated services to serve their users better. To enable the Libraries to meet the challenges of the next decade, it is important that the non-library functions included in the building be closely tied to the Library's mission.

The master plan has also identified expansion opportunities for both collections storage, user settings and learning space—ranging from options for on-campus storage in Goodell, options for expanding Du Bois at the Lower Level, and options for off-campus collections storage.

This chapter describing the master plan recommendations includes the following sections:

- 7.1 Du Bois Building Planning Principles
- 7.2 Du Bois Proposed Program Distribution
- 7.3 Library Staff Space
- 7.4 Key Space Concepts for New Facilities
- 7.5 Du Bois Stacking Analysis
- 7.6 ISEL as a Future Science Commons
- 7.7 Goodell Building Storage Options
- 7.8 Other Library Facilities
- 7.9 Expansion Strategies for Du Bois

# 7.1 DU BOIS BUILDING PLANNING PRINCIPLES

*Du Bois master plan recommendations were guided by the opportunities suggested by the building form itself, as explained in Chapter 3 and 6. This diagram recaps those primary strategies.*

- Conversion of carrel floors as a first target for repurposing underutilized space (4, 7, 10, 13, 16, 19, 22, 25)
- Relocate some of the print collections to consolidate the stack zones.
- Exploiting the lowest levels for heavy trafficked showcase functions by removing the odd Floor 3 which was not in the original building design, to create a high ceiling space
- Demolishing a portion of one typical double stack block to create a special destination—the Research Commons
- Developing the top floor as a shared facility for symposiums hosted by the Library on new forms of scholarship and research

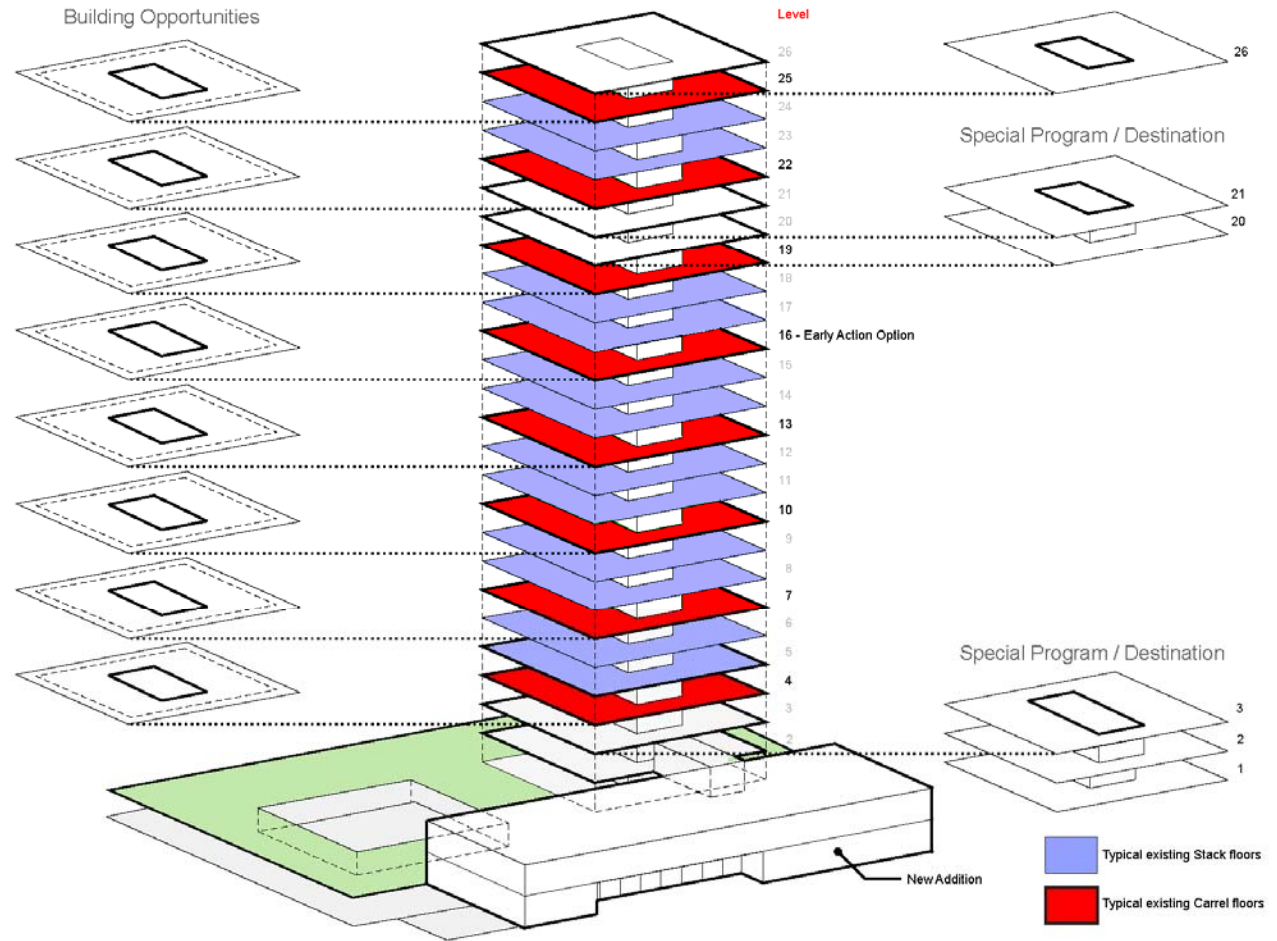



# DU BOIS PLANNING PRINCIPLES

- **Minimize major renovation** by retaining existing stack floors where possible
- **Locate heavy traffic spaces low in the building**, to reduce load on elevators and encourage use of side stair
- **Repurpose inefficiently used space and enhance shared uses over time**
- **Remove awkward infill structure at 3<sup>rd</sup> floor** to create a Learning Studio on 2 with high ceiling space
- **Create Research Commons** with a special space as focus to bring people together
- **Consolidate and enlarge Special Collections** to adequately accommodate and showcase the collections
- **Create additional Learning Studios** in the Learning Commons, which could be scheduled classrooms
- **Plan informal learning space adjacent to classrooms**
- **Increase the number of user seats** to serve population growth, especially collaborative settings
- **Enhance the top floor as a shared campus destination** that aligns with the Library's mission

- BUILDING CORE
- PUBLIC / SOCIAL
- COLLECTIONS
- OFFICE
- STUDY SPACE
- MEETING SPACE
- CLASSROOM
- STORAGE
- ★ SERVICE POINT

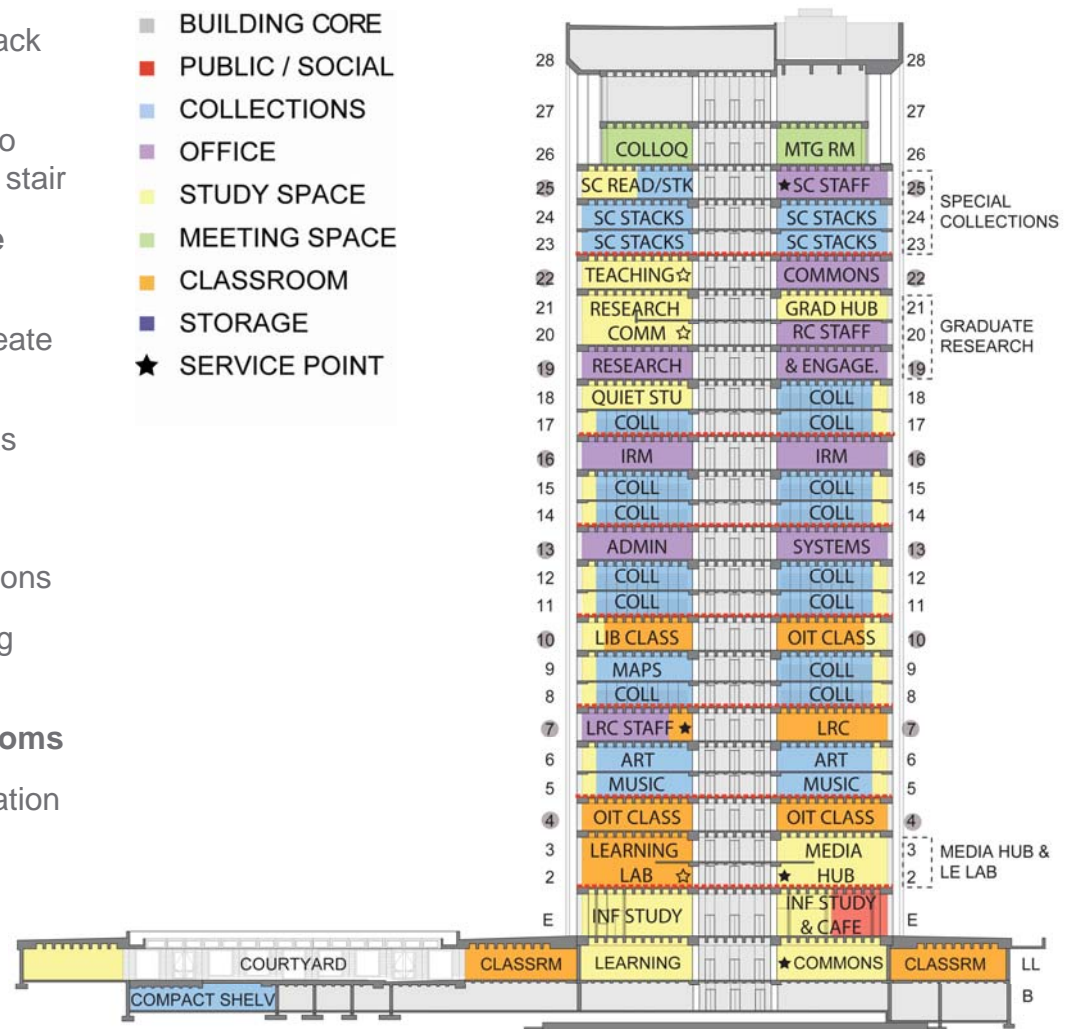

## 7.2 DU BOIS PROPOSED PROGRAM DISTRIBUTION

The proposed master plan distributes the projected program for 2020 based on the planning principles. The existing self-supporting stack levels are proposed to be retained, as that will avoid the need to replicate building new stacks on other floors. It also compacts them into low ceiling space not easily used for other functions.

The future Library will expand its function as a learning center by adding space for study and teaching. Most heavily trafficked functions, especially scheduled classrooms, for the most part will be located at the lower levels. More space to expand the Learning Commons will be created by relocating some of the staff functions off that floor and converting the regained space for more user seating and an additional learning studio, totaling three classrooms at the Lower Level by 2020. The café on the 1<sup>st</sup> floor will be expanded, blended with additional informal study seating with expansive views out to the pond.

Immediately above the entry level, a large demonstration Learning Studio will be developed on half the floor by removing the 3<sup>rd</sup> floor structure to create a high ceiling space. On the other side of the 2<sup>nd</sup> floor, the Media Hub will be easily accessible one level up from the entry, located to allow students to spill out of classes and continue to work on team projects with a range of media. The Image Collection library is proposed to be relocated into Du Bois as its digitization function lessens and its role in promoting use of digital images and media in projects and research broadens in its application.

Once the new classrooms are up and running, the Library Administration will be relocated further up in the building, along with the Library Systems group, to free up the existing 4<sup>th</sup> floor to a function that will benefit from walkup access from the monumental stair. The OIT classrooms are proposed to be located on the 4<sup>th</sup> floor once it is renovated.

Relocations in the mid-levels were driven mostly by the logic of sequencing of renovation. The popular Learning Resource Center will be relocated down to the 7<sup>th</sup> floor once it is vacated and expanded. Additional classrooms managed by both OIT and Library will then be located on the 10<sup>th</sup> floor once the former LRC space has been renovated.

The Research Commons is proposed to be located on the 20<sup>th</sup> floor, with a mezzanine level housing the Graduate Hub on 21<sup>st</sup> floor. One floor below the Research Commons will be the floor devoted to Research & Engagement offices, allowing convenient access between facilities and staff on each floor. In the same part of the tower, the Teaching Commons will be another faculty-oriented facility just above the Research Commons for convenience.

Special Collections & University Archives will be located at the top of the building due to its low traffic level. The SC Reading Room and staff space will be renovated on the 25<sup>th</sup> floor, which as a typical carrel floor has toilets and higher head room than the stack floors below. The Symposium space on 26<sup>th</sup> floor will enable the Library and Research & Engagement to organize special research gatherings.

# PROPOSED PROGRAM DISTRIBUTION

## EXISTING

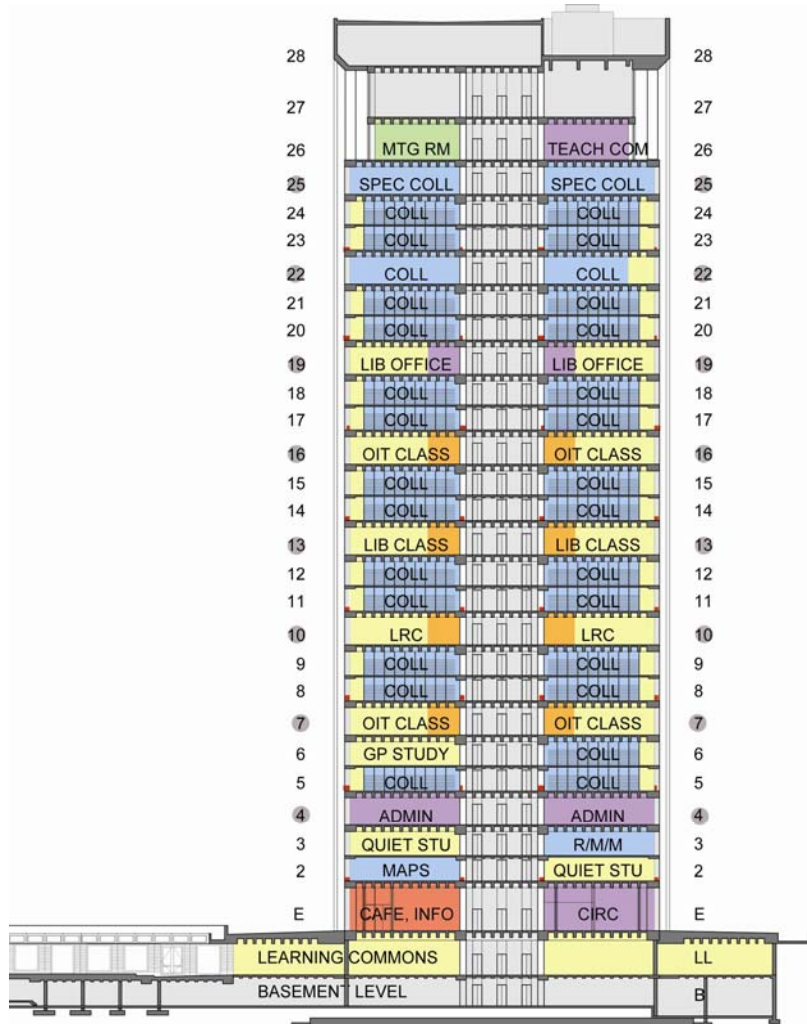

## PROPOSED

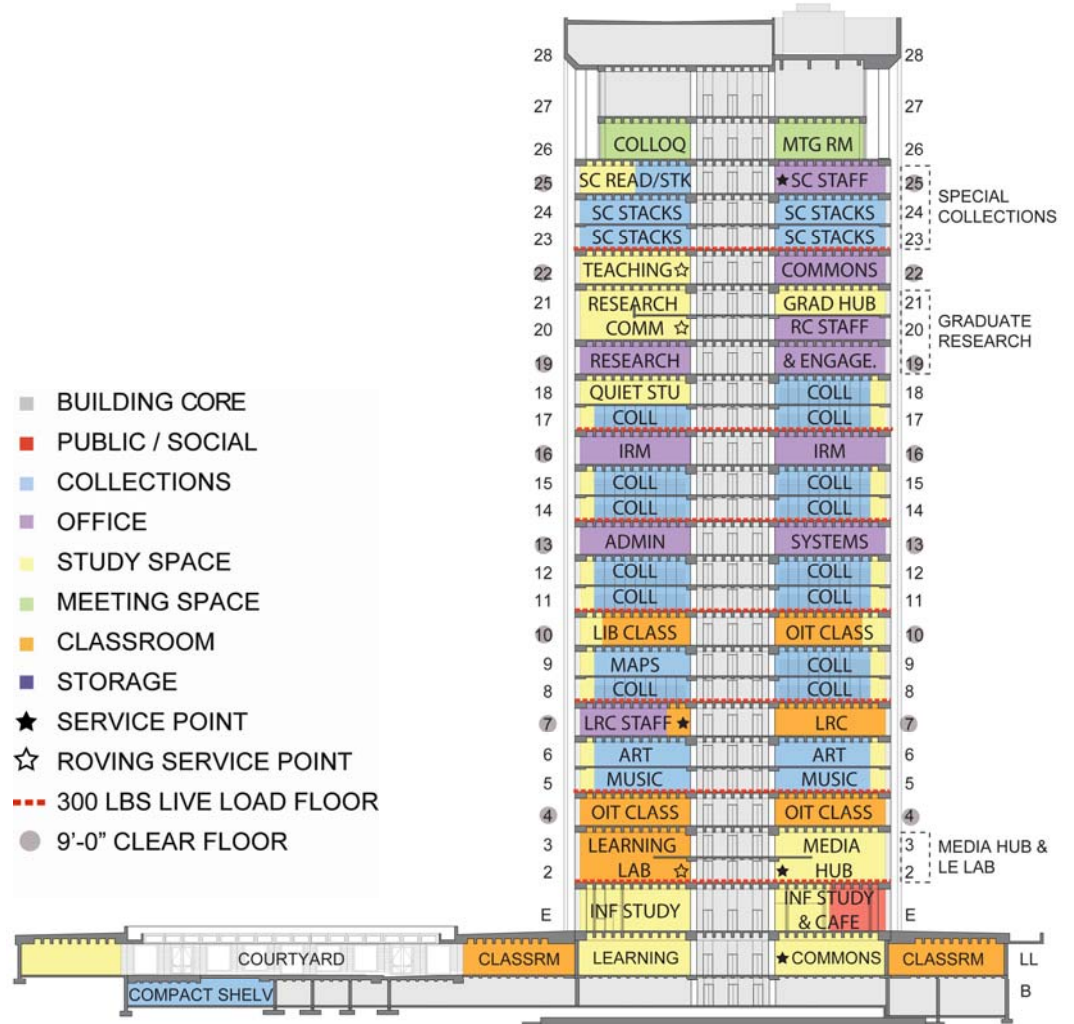

# DISTRIBUTION OF FUNCTIONS & SEATS

This diagram summarizes the capacities of the primary distributed program components and where they are located in the building:

- informal study seats
- classroom seats
- meeting room seats, and
- workspace seats.

The most trafficked areas are proposed for the lowest levels, the Lower Level and the 2<sup>nd</sup> floor. Similarly other classrooms for LRC, OIT and Library are kept on lower levels. Functions in the middle floors of the tower have low to moderate traffic, and are less susceptible to spikes in traffic load. Although the top floor has large capacity meeting rooms, they will tend to be used episodically and have low traffic in between.

See page XX for further information on the seating analysis.

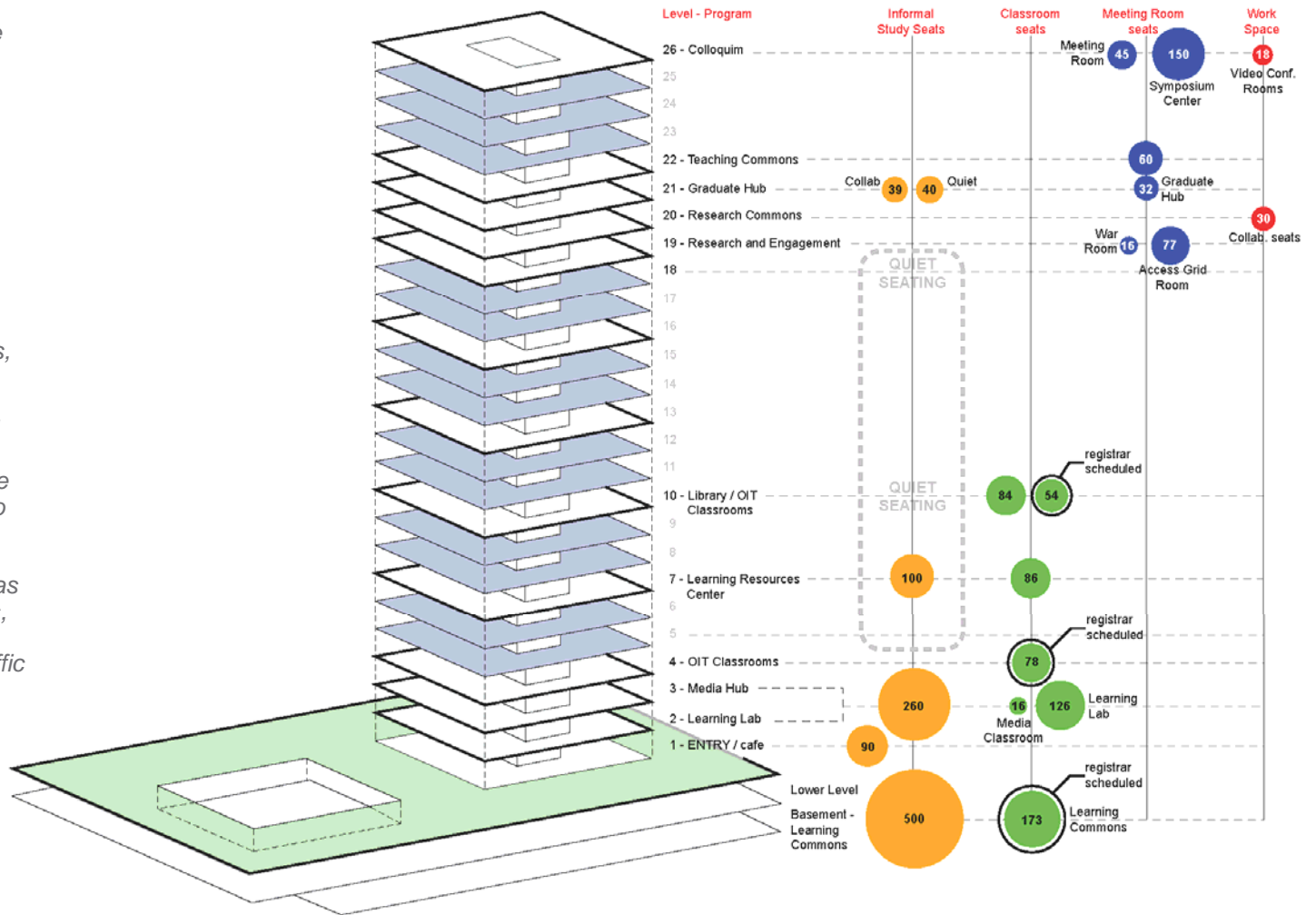



# PEOPLE FLOW

The relative flows of pedestrians to various levels of the building with the proposed program distribution are illustrated in this diagram. It displays visually the loads based on seating capacities, both estimated average and peak loads.

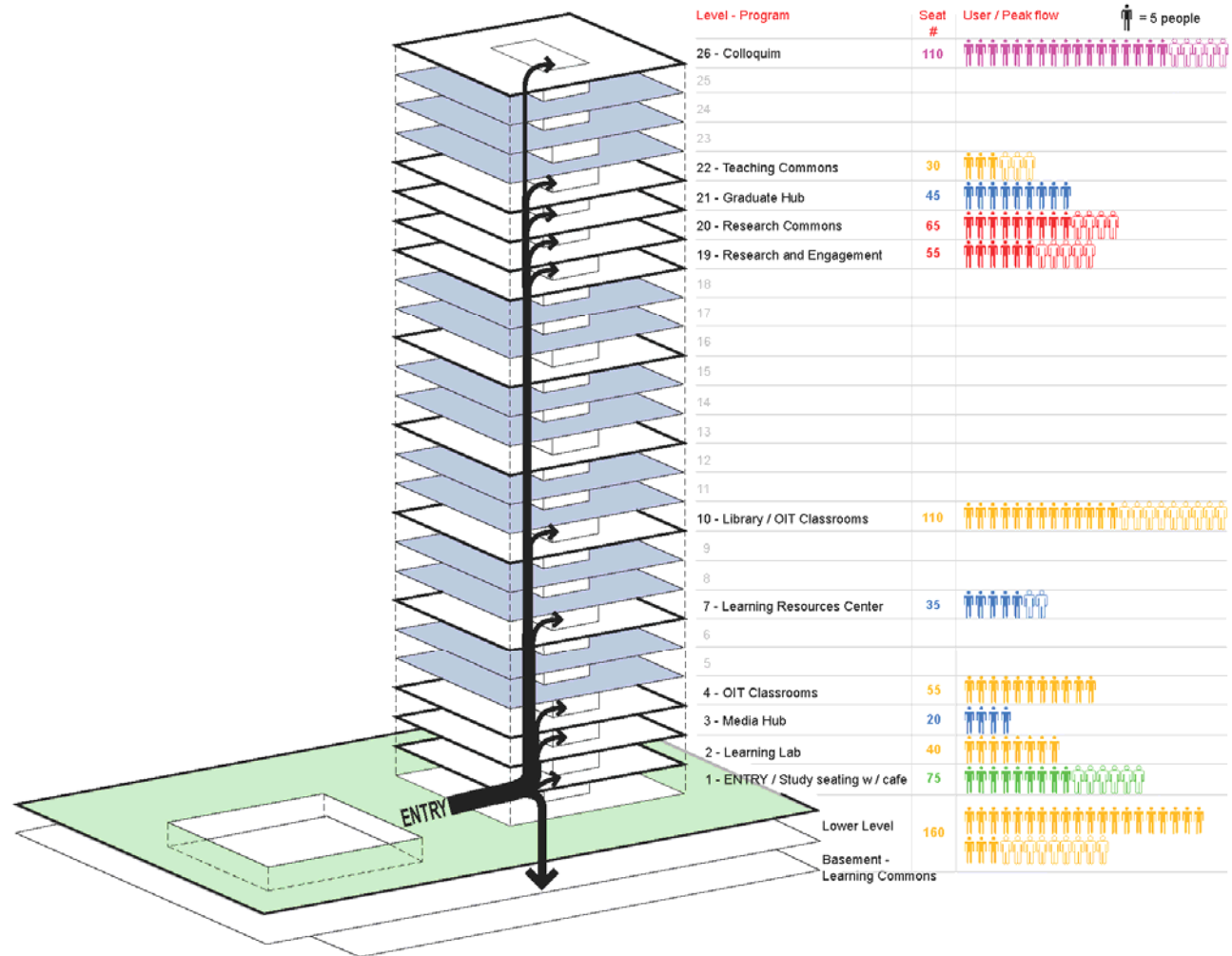

## 7.3 LIBRARY STAFF SPACE

As of July 2010, several of the library staff groups have been consolidated down on the Lower Level: Information Resources Management (IRM), Access Services (formerly Circulation & ILL), and Research & Liaison Services (formerly Reference Services). However, over a ten year period, it will be desirable to reclaim some of the Lower Level for expanded user spaces to avoid adding heavy traffic to the elevators, to use prime space more intensively at off-hours, and managed active study space at night more efficiently.

The master plan recommendations propose that the **IRM unit be relocated onto an upper tower floor**. IRM has little need for direct contact with users, but as staff roles evolve from print processing to acquiring and managing digital resources, proximity to the Research & Liaison librarians in the Research Commons will be beneficial. It is also feasible that if Goodell gets developed with a loading dock to serve the library, that the processing unit might end up located there.

The **Research & Liaison Services group is proposed to be located in the Research Commons**, co-located to provide essential services for faculty and researchers, and adjacent to the **Scholarly Communications** group.

**Library Administration** will be relocated to an upper floor to free up the 4<sup>th</sup> floor for student-oriented functions near the monumental stair.

**Library Systems** will also relocate with the Administration. The server room would relocate with the Systems group, assuming that during a major renovation a duplicate facility may be required to assure that library systems remain operational during renovation. This would need further study for confirmation.

**Access Services** will remain consolidated on the Lower Level. Having the circulation desk at that level puts the primary service point where the most users are, and allows the desk to help supervise that half of the floor at off-hours.

**Undergraduate Teaching & Learning Liaison** librarians will remain based in the Learning Commons, together with Learning Commons staff and a few reference librarians to assist learners in the Commons.

**Special Collections & University Archives** staff will remain on the 25<sup>th</sup> floor in expanded and improved workspace.

See the summary detail breakdown of the program for staff spaces in Appendix 1 for further information on assumptions about projections for future staff space.



# MATERIALS FLOW

Materials handling flow needs to be evaluated in a library system of this size. Print materials are brought in at the loading dock and taken to the Information Resources Management (IRM) where they are processed before being taken to Access Services for shelving or distribution. Today IRM is on the Lower Level, but the proposed plan shifts IRM to an upper level in the tower to free up needed user seating area for the Learning Commons. Although this will require all print materials to be brought up by elevator, it is anticipated that the load of print processing will be diminishing over time. An elevator load study is recommended.

Access Services sorting is recommended to be consolidated near the staff that supervises it, so proposed to be moved from the 1<sup>st</sup> floor to the Lower Level adjacent to the service desk, avoiding today's congestion in the 1<sup>st</sup> floor lobby. Reserves staff will be conveniently located above the collections they page.

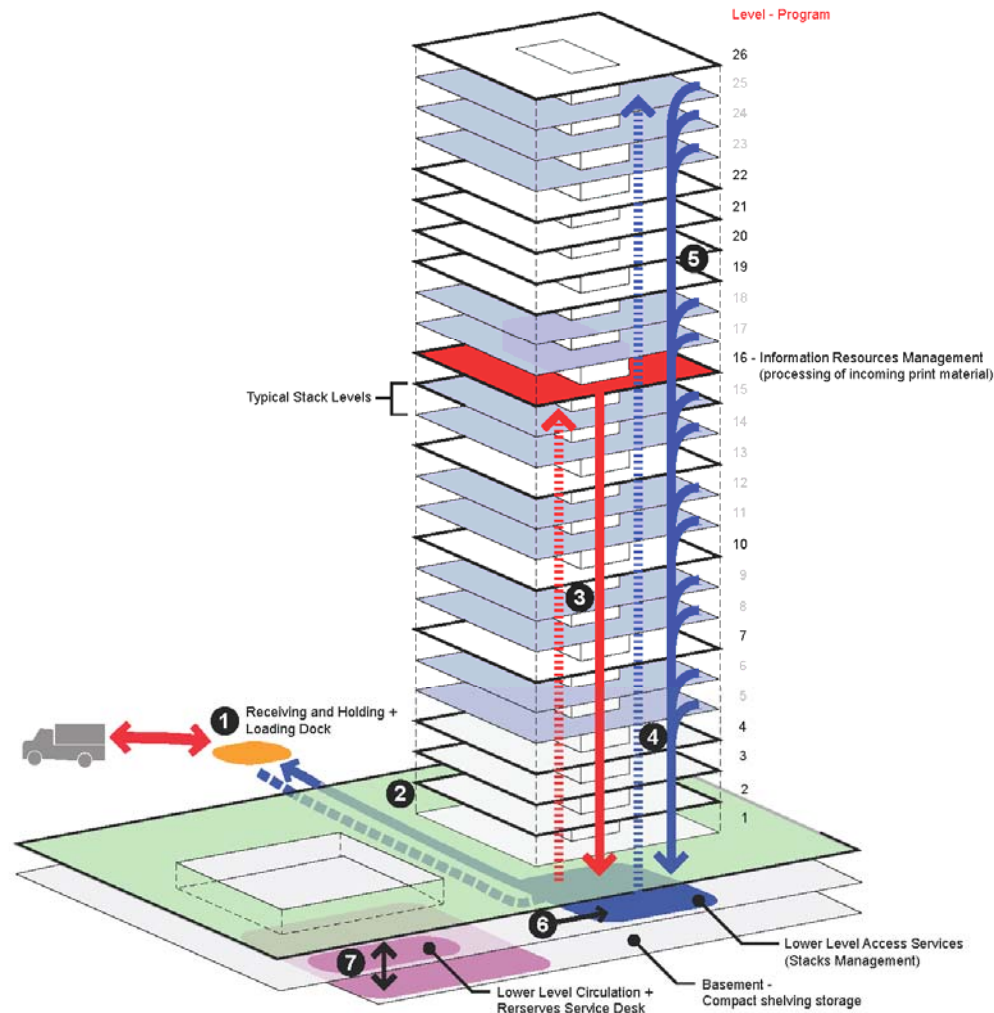

## Legend

- 1 Receiving and receipt of deliveries.
- 2 Deliver to IRM on floor 16 for sorting.
- 3 Transport by elevator to Lower Level Access Services for sorting.
- 4 Distribution to stacks by Stacks Management.
- 5 Pulling material from stacks for Lower Levels, reshelving, bindery and offsite storage.
- 6 Collecting print materials daily & returning them to stacks by Stacks Management.
- 7 Paging material from Basement storage by reserves staff.

# LIBRARY SERVICE POINT STRATEGY

The strategy for the master plan consolidated library service desks and distributed them at various levels in the tower, in the following locations:

- **Library Service Desk** at the Lower Level (circulation/reserves/ microforms desk)
- **Learning Commons desks**, offering integrated services for assistance with technology and reference questions
- **Academic Advising desk** in the Learning Commons
- **Security point** at entry
- **Media Hub**, on 2<sup>nd</sup> floor, with integrated staffing involving Image Collections staff, OIT and others
- **Music Collections desk**, on 5<sup>th</sup> floor, to provide specialized assistance with the wide range of materials. This service point may also be used for those with inquiries about the Art Collection.
- **Research Commons**, on 20<sup>th</sup> floor
- **Special Collections Room**, on 25<sup>th</sup> floor

Other desks, e.g. at the Learning Resources Center and Teaching Commons, will be operated by partners.

The intent over time is to reduce the need to station trained library staff at a desk for rotating hours. For example, the Research Commons will be designed more like a triage point, where users are referred on to meet with the most appropriate specialist for their needs. In an increasingly mobile world, roving staff will be equipped to respond when contacted by users regardless of locations.

Another objective of the master plan is to promote integrated services with partners, seeking ways to make service points less specialized (as users have difficulty distinguishing the differences anyway) and more diversified in the services offered.

# SERVICE POINTS ANALYSIS

The visioning process explored what types of services users might seek in the future and what service points they might go to for those services.

UMass Amherst Libraries											DEGW
Service Design Matrix											
3/31/2010											
Activity	Service Points										
	Entry	Circulation Desk	Learning Commons	Media Hub	Teaching Commons	Research Commons	Roving Staff	Specific Location	ISEL Service Desk	Virtual Support	
Get a visitor's pass	x								x		
Pay a fine		x							x	x	
Claim a lost/found item	x										
Ask Access Questions (e.g.: PIN)		x	x				x		x	x	
Pick up Interlibrary Loan item		x							x		
Meet class/group for library tour	x								x		
Ask University-related questions (e.g.: directions)	x	x	x	x			x		x	x	
Get a drink or snack								Café			
Library wayfinding assistance	x	x	x				x		x		
Attend library instructional session								Classroom			
General Research Consultation (how to search)			x			x	x		x	x	
Question about search query (known item)			x			x	x		x	x	
Research consultation - discipline specific						x	x		x	x	
Research consultation - format specific						x	x		x	x	
Get information literacy assistance			x				x		x	x	
Pick up paged book/journal/item		x							x		
Check out book/journal/item		x							x		
Return book/journal/item		x							x		
Check out / return course reserve item		x							x		
Get help locating a book/journal/item		x	x				x		x	x	
Check out / return devices (ipod, laptop, gaming, etc)			x						x		
Device troubleshooting / repair			x						x		
Hardware Assistance - library owned			x	x			x		x		
Hardware assistance- user owned			x	x			x		x		
Software/resources assistance - general			x	x			x		x		
Software/resources assistance - advanced			x	x					x	x	
Printing assistance			x	x			x		x		
Training on innovative classroom / technology					x			Classroom			
Classroom/technology support			x		x			Classroom			
Reserve a group study room			x							x	
Reserve a classroom			x					Registrar		x	
Intellectual property assistance							x		?		
Grant-writing assistance							x		?		
Human-subjects research consultation							x		?		
Animal-handling research consultation							x		?		
Instructional design support					x						
Course materials development assistance					x						
Course evaluation/assessment assistance					x						
Attend tutoring session								LRC			
Attend class								Classroom			

# 7.4

## CONCEPTS FOR NEW FACILITIES RESEARCH COMMONS AND GRADUATE HUB

The research commons is a double height destination space that supports researchers with content development and with the tasks involved for the lifecycle of the project. The center consultation space is a double height space with an open stairs that connects to the incubator space and has direct access to the Graduate Hub. The deck in half of the upper level will be replaced to form a cut-out space in the center. The presence of the Research & Engagement office a floor below will make this a one-stop service center for research projects on campus.

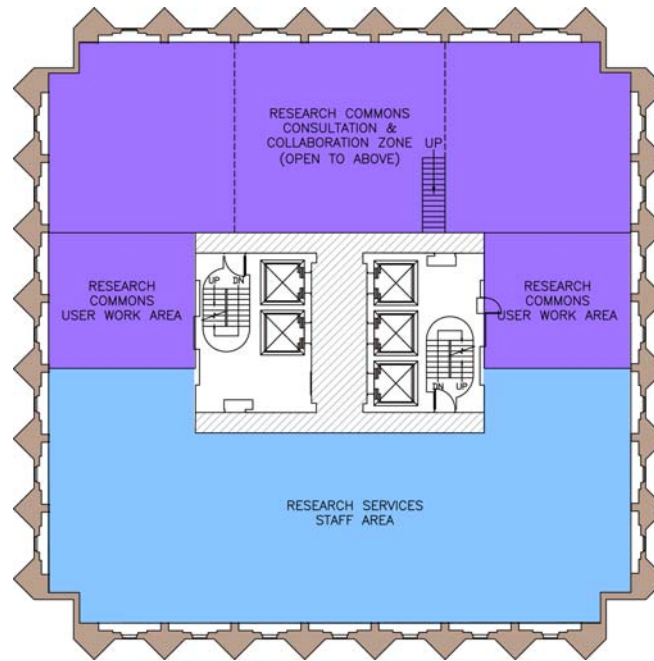

Typical Stack Floor  
8120 usf

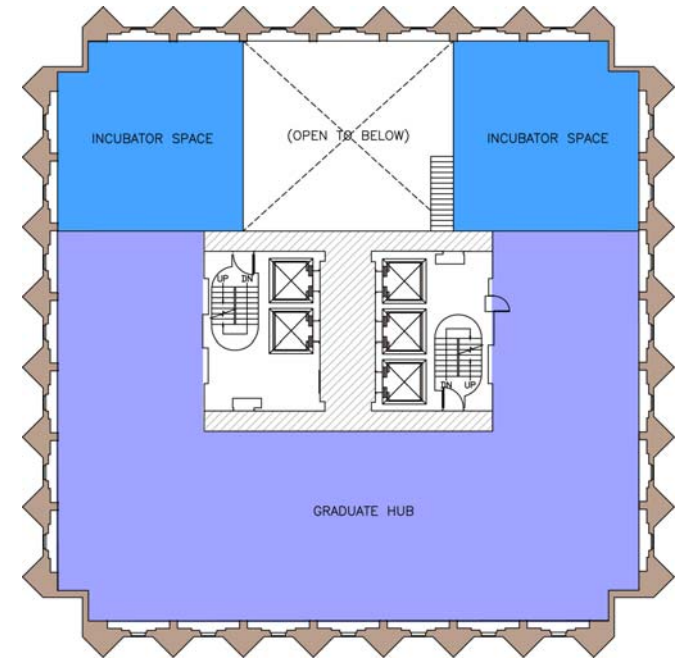

Typical Stack Floor - Mezzanine  
6940 usf

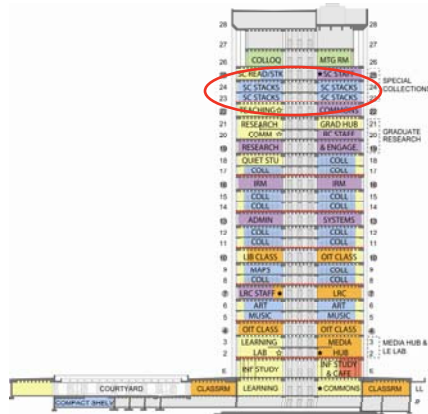



# CONCEPTS FOR NEW FACILITIES LEARNING STUDIO AND MEDIA COMMONS

The large learning studio's location at the 2<sup>nd</sup> floor will encourage students to use the existing monumental stairs rather than the elevators. Removal of the 3<sup>rd</sup> floor structure will help create the high ceiling that good sightlines will require. On the opposite side of the floor is the Media Hub, a two story suite with a high ceiling space at its center. It too is expected to generate heavy traffic. User seating and service desk staff will be on the lower level; Digital Image Collection/Media staff will be on the upper level, along with group viewing rooms.

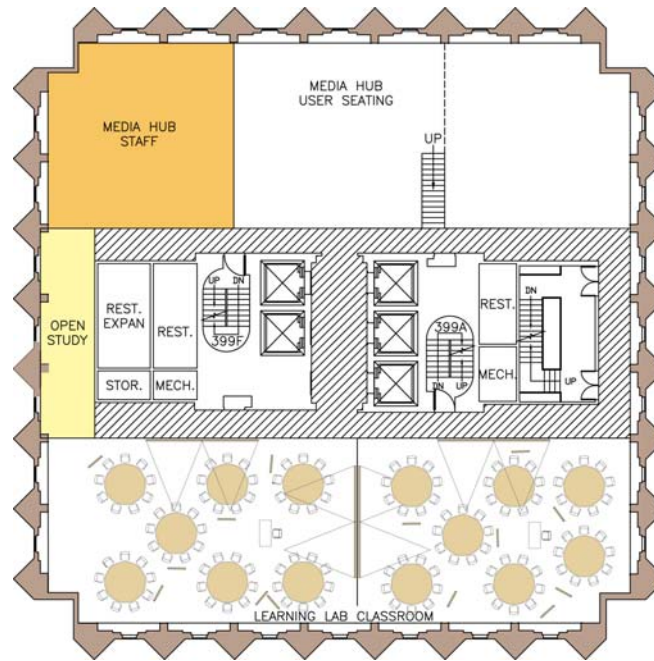

Lower Floor – Level 2  
6520 usf

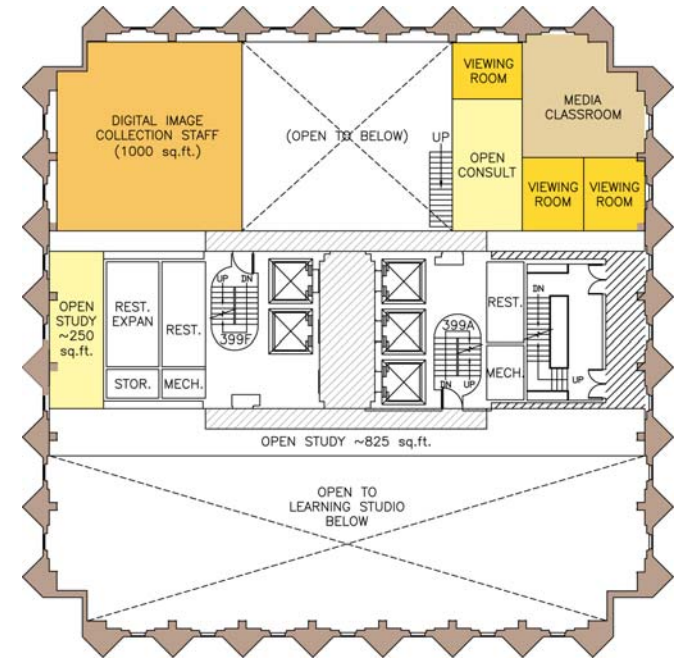

Lower Floor – Mezzanine Level  
4265 usf

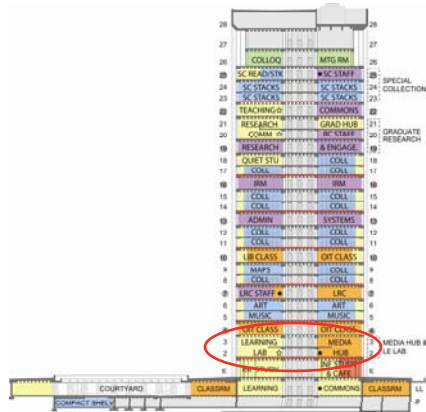

# CONCEPTS FOR NEW FACILITIES

## SPECIAL COLLECTIONS READING ROOM

An enhanced reading room with views high in the tower will be a scholarly destination in the Library to view and work with special materials. The grouping of open reading room along with closed consultation rooms will enable students/faculty to comfortably work with artifacts for their scholarship and research projects. Staff spaces are on the same level to provide expert supervision. The two stack floors below it will accommodate the consolidated SC collections plus growth.

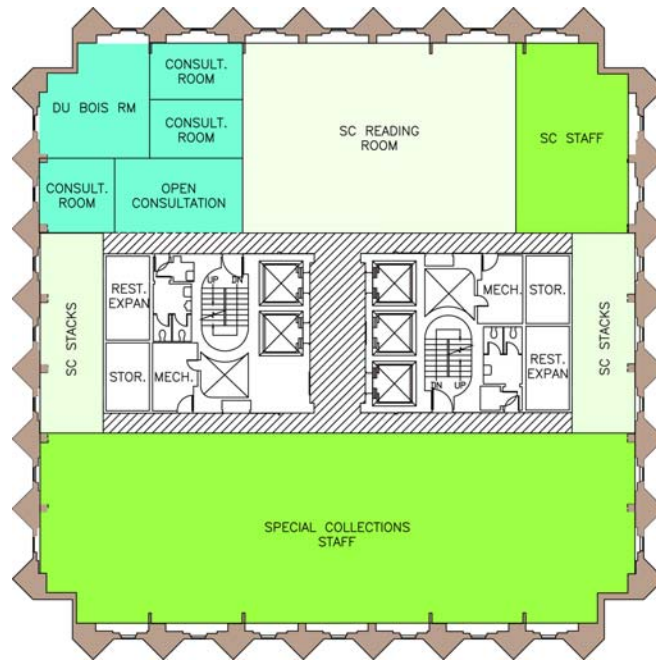

Typical Carrel/Study Floor  
7060 usf

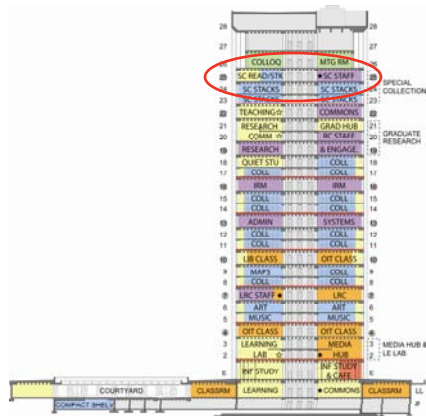



# 7.5

## DU BOIS STACKING ANALYSIS PAGE 1

Flr	Existing Space Use	Estim'd Existing Usable Area (usf)	Target Usable Area	Proposed Functions	Area USF	Difference	Notes	User Seating Distribution		
								Class-room seats	Study seats	Meeting Room seats
<b>26</b>		<b>4,830</b>	<b>4,830</b>		<b>4,810</b>	<b>20</b>				
	Teaching Commons			Colloquium Center	2700					150
	Meeting Room/ kitchenette			Meeting Room/ kitchenette	1570		Existing			45
				Videoconferencing Rooms	540		Existing			18
<b>25</b>		<b>7,060</b>	<b>7,060</b>		<b>7,038</b>	<b>22</b>				
	Spec Collections			Special Collections Reading Room	1,028		closed collection			15
	Study Carrels			Special Collections Staff	3,650					
				Du Bois Room	550					10
				Internal circulation	310					
				Special Collections Stacks	1,500					
<b>24</b>		<b>8,120</b>	<b>6,940</b>		<b>6,940</b>	<b>0</b>				
	Collections			Special Collections Stacks	6,940					0
	Seating									
<b>23</b>		<b>8,120</b>	<b>8,120</b>		<b>8,120</b>	<b>0</b>				
	Collections			Special Collections Stacks	8,120					0
	Seating									
<b>22</b>		<b>7,060</b>	<b>7,060</b>		<b>7,060</b>	<b>0</b>				
	East Asian Collection			Teaching Commons	2,460				50	10
	Study Carrels			Teaching Development Ctr staff offices	3,490					
				Quiet study	1,110					32
<b>21</b>		<b>8,120</b>	<b>6,940</b>		<b>6,970</b>	<b>-30</b>	<i>1,180 sf is open to below</i>			
	Music Collection			Graduate Hub	4,990		On Mezzanine level of Res Comm		79	32
	Seating			Incubator Zone	1,980				14	12
<b>20</b>		<b>8,120</b>	<b>8,120</b>		<b>8,120</b>	<b>0</b>				
	Collections			Research Commons: Consultation & Collaboration Zone	3,020				12	65
	Seating			Research Services Staff	3,700		<i>incl Scholarly Communications and Reference/Liaison Librarians</i>			
				Reseach Commons User Work Area	1,400				30	

# DU BOIS STACKING ANALYSIS

## PAGE 2

Flr	Existing Space Use	Estim'd Existing Usable Area (usf)	Target Usable Area	Proposed Functions	Area USF	Difference	Notes	User Seating Distribution		
								Class-room seats	Study seats	Meeting Room seats
<b>19</b>		<b>7,060</b>	<b>7,060</b>		<b>7,920</b>	<b>-860</b>				
	Library offices			<b>Research &amp; Engagmt:</b>			One floor down from Commons			
	Carrels			Grant & Contract Administration offices	4,670		Location on this carrel floor enables early construction			
				Research Affairs Offices	2,690					
				War Room	560		May need to shift to floor above			16
<b>18</b>		<b>8,120</b>	<b>8,120</b>		<b>8,120</b>	<b>0</b>				
	Collections			Collections	3,200					
	Seating			Quiet Seating	4,920				141	
<b>17</b>		<b>8,120</b>	<b>8,120</b>		<b>8,120</b>	<b>0</b>				
	Collections			Collections	6,250					
	Seating			Quiet Seating	1,870				53	
<b>16</b>		<b>7,060</b>	<b>7,060</b>		<b>7,760</b>	<b>-700</b>				
	OIT Classrooms			<b>Info'n Resources Management offices</b>	6,980					
	Faculty Writing Room			Integrated Library Systems	780					
	Study Carrels									
<b>15</b>		<b>8,120</b>	<b>8,120</b>		<b>8,120</b>	<b>0</b>				
	Collections			Collections	6,250					
	Seating			Quiet Seating	1,870				53	
<b>14</b>		<b>8,120</b>	<b>8,120</b>		<b>8,120</b>	<b>0</b>				
	Collections			Collections	6,250					
	Seating			Quiet Seating	1,870				53	
<b>13</b>		<b>7,060</b>	<b>7,060</b>		<b>6,740</b>	<b>320</b>				
	LRC Classrooms			<b>Library Administration &amp; Systems Offices</b>	6,440					
	Meeting Rooms			Shared Staff Work Rooms	300		Includes relocated server room			
	Media Viewing Stations									
	Study Carrels									
<b>12</b>		<b>8,120</b>	<b>8,120</b>		<b>8,120</b>	<b>0</b>				
	Collections			Collections	6,250					
	Seating			Quiet Seating	1,870				53	
<b>11</b>		<b>8,120</b>	<b>8,120</b>		<b>8,120</b>	<b>0</b>				
	Collections	6,200		Collections	6,250					
	Seating	1,760		Quiet Seating	1,870				53	

# DU BOIS STACKING ANALYSIS

## PAGE 3

Flr	Existing Space Use	Estim'd Existing Usable Area (usf)	Target Usable Area	Proposed Functions	Area USF	Difference	Notes	User Seating Distribution		
								Class-room seats	Study seats	Meeting Room seats
<b>10</b>		<b>7,060</b>	<b>7,060</b>		<b>7,070</b>	<b>-10</b>				
	Learning Resources Center			<b>Library Teaching Spaces</b>	3,360				84	
				<b>OIT Managed Classrooms</b>	2,810		Difference that does not fit on 4th floor. 1@1200; 2@480 = 54 sta		54	
	Study Carrels			Mixed Study Seating	900					26
<b>9</b>		<b>8,120</b>	<b>8,120</b>		<b>8,120</b>	<b>0</b>				
	Study Seating in Collections			Collections	3,200					
	Open Quiet Study			Maps Collection	2,500					
				Quiet Seating	2,420					69
<b>8</b>		<b>8,120</b>	<b>8,120</b>		<b>8,120</b>	<b>0</b>				
	Collections			Collections	6,250					
	Seating			Quiet Seating	1,870					53
<b>7</b>		<b>7,060</b>	<b>7,060</b>		<b>7,160</b>	<b>-100</b>				
	OIT Computer Labs	2,210		<b>Learning Resources Center</b>	5,030		Projected future LRC at 8,670 usf does not fit onto 1 floor, propose accommodating 1,520 sf addnl sp in Learning Commons		86	100
	Classrooms	1,580		LRC staff areas	2,130					
	Offices									
<b>6</b>		<b>7,060</b>	<b>7,060</b>		<b>7,060</b>	<b>0</b>	Assume 70 sf stair is filled in			
	Gov Docs, Patents/Tradm			Art Collection	4,760					
	General Coll. Collections			Quiet Seating	2,300					66
	Open Quiet Study									
<b>5</b>		<b>6,520</b>	<b>6,450</b>		<b>6,450</b>	<b>0</b>	70 sf is stair			
	Study Seating in Collections			Music Collection	4,760					
	Current Periodicals Lounge			Music Media Stations	600					20
				Quiet Seating	1,090					31
<b>4</b>		<b>6,520</b>	<b>6,520</b>		<b>6,570</b>	<b>-50</b>				
	Library Administration			<b>OIT Classrooms</b>	4,380		see also 10th floor		78	
	Server Room			OIT Staff	2,190					
<b>3</b>		<b>6,520</b>	<b>5,340</b>		<b>5,380</b>	<b>-40</b>	1,180 sf is open to below			
	Media Stations			<b>Media Hub Mezzanine:</b>						
	Microforms Stations			Digital Image Coll staff	2,190					
	Quiet Study Area			Media Hub user seating & viewing rooms	3,190					128

# DU BOIS STACKING ANALYSIS

## PAGE 4

Flr	Existing Space Use	Estim'd Existing Usable Area (usf)	Target Usable Area	Proposed Functions	Area USF	Difference	Notes	User Seating Distribution		
								Class-room seats	Study seats	Meeting Room seats
<b>2</b>		<b>6,520</b>	<b>6,520</b>		<b>6,520</b>	<b>0</b>				
	Maps			Learning Lab Classroom	3,160		Half floor only	126		
	Quiet Study Area			Media Hub:			Half floor only			
				Media Hub staff	1,130					
				Media Hub classroom	480			16		
				Media Hub user seating	1,750		Music media sta with music coll.		68	
<b>1/E</b>		<b>4,300</b>	<b>4,300</b>		<b>4,225</b>	<b>75</b>				
	Entry desks & seating			Entry zone	1,360				20	
	Café			Study seating with café	2,865				86	
	Stack Management	625								
<b>LL</b>		<b>50,000</b>	<b>50,000</b>		<b>48,323</b>	<b>1,677</b>	existing usable per inventory			
	Learning Commons			Learning Commons:						
	LC Service desks	2,020		LC Service desks	2,670					
	LC Classrooms	3,185		LC Classrooms	5,380		future with 3 classrooms	173		
	LC User Seating	15,025		LC User Seating	24,500		(1,520 usf to be for LRC use)		587	
				Public circulin in LngCom	6,330		estimated main egress paths			
	LC Staff and Research & Liaison Serices Offices	4,392		LC Staff & Library UG T&L Liaison Librarian Offices	1,030		(majority of Res Librarians to relocate to Res Commons)			
	Library Access Services	7,325		Library Access Services	7,640		(incl.Circ/Res desk, Access Services work areas, ILL, stacks mgmt sorting area)			
	Central Telcom	313		Central Telcom	313					
	Shipping & Receiving	502		Shipping & Receiving Room	460		(Existing breakdown being verified by UMA after recent moves.)			
<b>B</b>		<b>41,069</b>	<b>41,069</b>		<b>38,589</b>	<b>2,480</b>	diff is additional circulation			
	Collections in existing compact shelving (SC)	3,308		Collections in existing compact shelving (SC)	3,308					
	Library storage spaces	33,575		Library Storage - either compact shelving or other	31,095		Maximum compact shelving area is 31,095 sf assuming any existing functions in that zone are moved			
	Central telecom	4,186		Central telecom	4,186		Utility/General Bldg Areas are not usf.			
<b>Totals - Du Bois Building Usable Area Comparisons</b>		<b>280,199</b>	<b>276,589</b>		<b>273,785</b>	<b>2,804</b>	excludes Sub-Basement	<b>617</b>	<b>1,894</b>	<b>358</b>

## 7.6 ISEL AS A FUTURE SCIENCE COMMONS

The master plan proposes that the Integrated Science & Engineering Library (ISEL) in the Lederle complex be transformed into a **center to support research in science and engineering**. Similar to the Research Commons in Du Bois but with a scientific focus and consulting expertise, librarians expert in e-science resources and data-rich research would provide integrated services to research teams together with Research & Engagement staff and provide support to STEM students in their study and projects.

Much of the bound journals and older monographs from the 3<sup>rd</sup> floor can be relocated into off-campus storage (see Chapter 5 on Needs Analysis), allowing the space to be renovated as collaborative and quiet work space needed to meet the demand of the future science population. This is good space for open plan library areas, with features like high ceilings, reasonable column spacing and good natural light access from generous windows on both sides of the bridge on the upper levels. The lowest level already has compact shelving.

So these features guided the master plan's recommendations for fit of program to physical space and in response to future needs that emerged during this study. However, there are institutional pressures to use the 3<sup>rd</sup> floor of the ISEL space for expansion of Chemistry labs.





## IMPACT OF THE CHEMISTRY OPTION

**THE NEED:** The Comprehensive Science and Engineering Facilities Plan in 2009 identified the need to bring Chemistry labs down to lower levels of the Lederle complex when it is renovated. The plan proposed expanding Chemistry lab space into the bridge zone, displacing the 2<sup>nd</sup> and 3<sup>rd</sup> floors of ISEL library space.

Since then issues have been raised which may impact that recommendation: e.g. whether one floor of Chemistry labs in the bridge zone will be sufficient rather than two levels, and whether fume hoods can terminate at a low roof adjacent to the higher adjacent structures.

**SCHEDULE ISSUES:** Another aspect for this decision is the schedule for when this major renovation involving Chemistry would actually occur and whether the space can be effectively used for other purposes in the interim while funding is secured. The pressing need to relocate Research & Engagement (R&E), a function more compatible with the library mission, is also high priority. The top floor of ISEL could become available for renovation immediately once the bound journals there can be consolidated and/or shifted to storage. So either all of the R&E offices could move to the 3<sup>rd</sup> floor, or they could move to Du Bois with the CVIP group in Lederle integrated into an upper portion of a new Science Commons. The latter option is what has been proposed in the Libraries master plan.

**IMPACT ON LIBRARY SERVICES:** Even if chemistry takes only the 3<sup>rd</sup> floor, compressing the proposed Science Commons onto the 2<sup>nd</sup> floor would compromise the concept: there would be insufficient space for integrating R&E staff with Library staff and for new meeting and visualization facilities needed for collaboration in e-science development.

With conversion of both 2<sup>nd</sup> and 3<sup>rd</sup> floor to Chemistry, loss of user seating becomes a significant concern. Many students come to ISEL to work, so to meet campus study seating needs in 2020, alternative locations for study seating would have to be determined. Additional stack floors in Du Bois might have to be removed from browsing access and more books put into storage in order to create a new science library. But the primary impact will be losing facilities convenient to busy STEM students and faculty within the science sector of the campus, with convenient staff to assist them. If ISEL has to be relocated to Du Bois, use is likely to drop and a big opportunity will be missed to create a vibrant science commons.

The 1st floor of ISEL has narrow windows as it was built for stacks so is compromised as open reader or staff space. Entry at that level would be awkward because of the core locations, so entry at 2<sup>nd</sup> floor is still preferable. If the basement and 1<sup>st</sup> floor are retained as book storage, then circulation must be planned to keep the books secure.





# ISEL SCIENCE COMMONS OPTION 1

The existing entry on the 2<sup>nd</sup> floor would provide monitored access to the Science Commons and other levels. Glass walls along the bridge connector would provide views into the collaborative areas and displays about current research at UMass. A small café is proposed along the bridge that would open into the Commons, creating a vibrant blended informal destination for sharing, interaction and collaborative work.

Research Services staff would be conveniently located there, as would a teaching lab. The Science Commons would extend to the floor above but with more quiet work zones as well as consultative areas. The CVIP offices would be located near the stair, adjacent to the Access Grid conference room and the War Room for grant prep and other short-term special projects.

The reduced science and engineering print collections would be stored in the two lower levels (with compact shelving at basement).

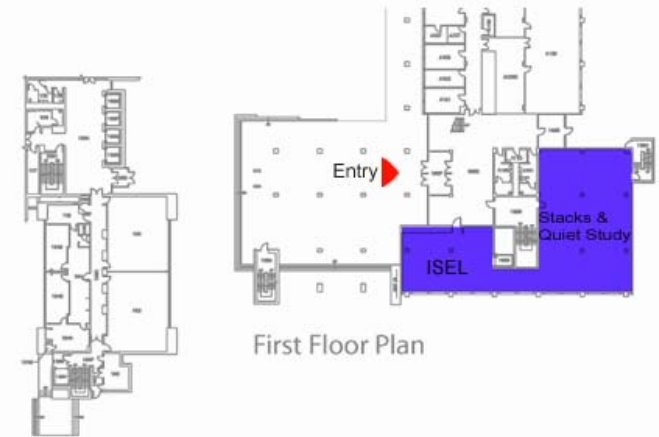
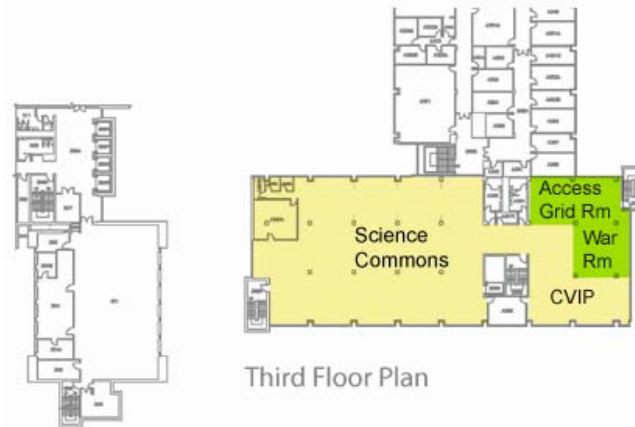

# ISEL SCIENCE COMMONS OPTION 2

In this second option, the entire bridge zone of the 3<sup>rd</sup> floor would be occupied by Research & Engagement workspace, with the zone near the stairs as shared meeting areas and a learning studio.

The 2<sup>nd</sup> floor would be similar to Option 1.

Fir	Existing Space Use	Stacks/ Existing Usable Area (sqf)	Seat Counts	Target Usable Area	Bridge/West Block Proposed Functions	Area Center Zone USF Proposed Functions	Area East Block USF Proposed Functions	Area USF	Difference
3				12,385		8,350	335	3,700	850
	Open study seating	1,422	57		Research & Engagement	Science Commons	Science Commons		
	Perimeter study seating	406	17		Commercial Ventures & IP	1,800 Display and reception seating	326 Collab. workareas & small grp mtg rms	1000	
	Lounge seating (at windows)	227	6		Research Affairs	2,070	AccessGrid/Visualization Forum*	700	
	Computer workstations	110	4		Grant & Contract Admin	3,580	Wlr Room	690	
	Non-Stack Areas:	2,357	84				Learning Studio	600	
						7,840	338	3,690	11,636
2				9,835		5,760	725	3,350	927
	Open study seating	5,700	230		Science Commons	Science Commons	Science Commons		
	Table seating (around stacks)	298	10		Collaborative worksta	990 Entry zone seating	300 Research Services staff workspaces	1,300	
	Lounge seating (at offices)	215	6		Group meeting spaces	2,000 Service desk	420 Service desk staff	806	
	Computer workstations	440	15		Table seating	2,750	Consultation Rms	300	
	Non-Stack Areas:	6,873	262		Cafe	300	Support	190	
					Lounge seating	160			
						5,790	720	2,428	8,908
1				4,940		1,350	265	3,325	0
	Perimeter study seating	300	12		Quiet study/windows	1,750 Service passage	265 Quiet study/windows	700	
	Stacks	4,580			Stacks	1,000	Stacks	2,800	3,800
						1,175	265	3,500	4,940
B				2,050		0	0	2,050	
	Stacks - compact shelving						Compact Shelving	2,050	
	Totals								
	Quiet study	8,730	336						
	Computer workstations	550	18						
		9,280	357						

## 7.8 GOODELL BUILDING

### **Option for Compact Shelving in Basement Level of Goodell Addition Building**

*If compact shelving in the basement of Du Bois cannot be provided (or was delayed in implementation), the 1<sup>st</sup> floor of Goodell Addition could be converted to compact shelving for storage of print materials. Potential capacity at this level is estimated at 28,500 linear feet assuming 5 shelves high shelving would be feasible.*

*Currently there is library book storage located on the 2<sup>nd</sup> floor, used for SC&UA materials. The 2<sup>nd</sup> floor, however, would not be able to support compact shelving. Capacity of the existing regular shelving there was estimated at 9,000 linear feet by the UMA library, so the combination of the two could total 37,500 LF.*

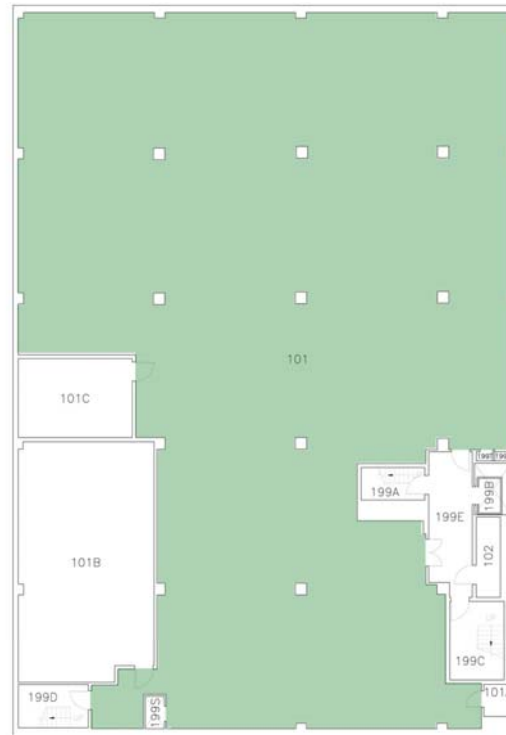

FIRST FLOOR PLAN  
room 101: 9,865 sq. ft

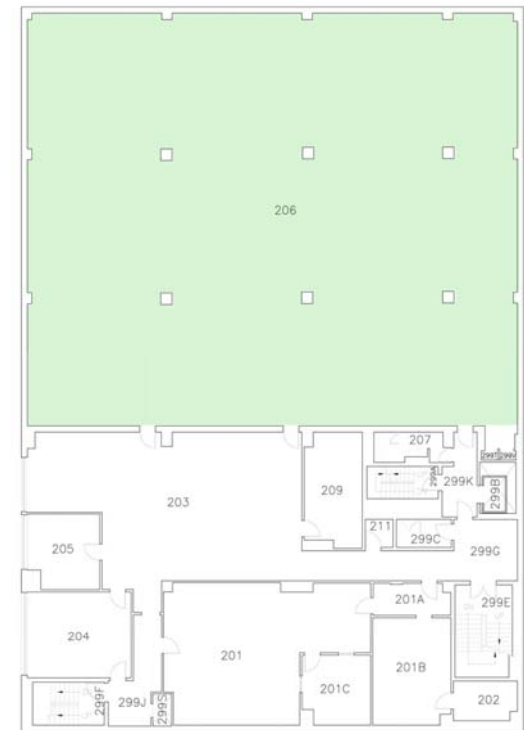

SECOND FLOOR PLAN  
room 206: 7,254 sq. ft

# GOODELL STORAGE CAPACITIES

## STORAGE CAPACITIES OF OPTIONS

	Room No	Room area (nsf)	Length of ranges (1)	No of single faced ranges	Linear feet of compact shelving in plan (single faced)	Linear feet of regular shelving in plan (single faced)	Linear feet of compact shelving at various heights			
							5 shelves	6 shelves	7 shelves	
<b>GOODELL BUILDING</b>										
Fifth Floor	501/502	2,056								
Fourth Floor	409	2,056	30	44	1,320				7,920	
Second Floor	206	7,254				9,000				
<b>Goodell Addition</b>							9,000	9,000	9,000	
First Floor	101	9,865								
<b>Goodell Addition</b>										
B1 zone			74	22	1,628		8,140	9,768	11,396	
B2 zone			74	22	1,628		8,140	9,768	11,396	
B3 zone			55	18	990		4,950	5,940	6,930	
							21,230	25,476	29,722	
B4 zone			30	22	660		3,300	3,960	4,620	
B5 zone			40	20	800		4,000	4,800	5,600	
							7,300	8,760	10,220	
							<b>28,530</b>	<b>34,236</b>	<b>39,942</b>	
<b>Total potential shelving capacity estimated for Goodell (3)</b>								<b>37,530</b>	<b>43,236</b>	<b>56,862</b>

Notes:

- (1) Assumes cross aisles of 5'
- (2) Estimate provided by UMA Library.
- (3) Estimated maximum, without working capacity factor deducted.

## 7.9 OTHER LIBRARY FACILITIES

### **FINE ARTS LIBRARY**

The other Library facility on-campus is the Fine Arts Library Reserves Lab, which the master plan assumes will remain in the Performing & Fine Arts Building. The Art print collection will be housed in Du Bois.

### **MUSIC LAB**

The Music Listening Lab will be integrated into Du Bois, adjacent to the print Music Collection and convenient to assistance through the new Media Hub.

### **THE FIVE COLLEGE DEPOSITORY**

The 5-College Depository in Amherst is currently being studied by the consortium to determine costs for expanding the storage capacity there. The schedule for determining costs and negotiating between the institutions is not certain, however, so the UMass Amherst Libraries master plan is proposing several alternatives for storage for either temporary or long-term use so UMass can have flexibility over the near term.

### **DISTRIBUTED LEARNING COMMONS**

In addition to the libraries on campus, there is need across campus for additional study and collaborative computing spaces, especially in the residential complexes, ideally supported with learning support services like those available in the Learning Commons.

The concept of Distributed Learning Commons was raised by the team during the study to meet expressed needs and as a support for a robust living-learning environment at UMass. These facilities for study and learning with peers need not be staffed, but could provide access to library reference staff virtually to assist on demand with resources and undergraduate research. This concept would need to be studied further as the master planning for the campus progresses.



## OTHER POTENTIAL EXPANSION STRATEGIES

**Tunnel Connection:** Although the Goodell Addition is fairly close to Du Bois, the storage there is still in a separate building and requires staff to travel back and forth. Goodell does have a loading dock, which might offer advantages if the existing loading dock serving Du Bois gets shut down during renovations at the South College building area. In that case, a connecting tunnel to Du Bois would be needed. Goodell may also offer a future option for relocating the Information Resources Management processing group, as convenient access to a loading dock is desirable for that.

**Underground Stacks:** Expanding the library with an underground storage facility between Du Bois and Goodell was one of the opportunities raised in chapter 3. This has been done successfully at other libraries, with minimal impact on the campus landscape, such as at the University of Virginia Small Special Collections Library, which has underground stacks with skylights in the lawn bringing light down into the reading room.

The location between Du Bois and Goodell would allow a connection between buildings at the Lower Level, convenient for Access Services staff (located at that level) who need to retrieve books and access a loading dock.

The issue of how the Chapel building might be repurposed and renovated in the future was not part of the scope of this study but would need to be studied with this option.





# 8



## IMPLEMENTATION ISSUES

Phasing Options and Logic

Cost Implications

Coordination Process

Conclusions



## 8 IMPLEMENTATION ISSUES

This study identified potential renovations of the library that could be made given the availability (or not) of immediate funding, its projected needs and the possible integration of other compatible uses. Depending on how these choices get prioritized relative to other pressing needs, the sequencing of renovation will differ.

Initial enabling moves involve shifting collections into storage facilities to create new usable space for other functions—whether consolidation into compact shelving, shifting to basement space, or moving volumes off campus. The following page outlines these key enabling choices for collections accommodation.

The phasing table that follows outlines a recommended plan of action that takes advantage of the locations that can be freed up for the off-site storage of print materials and developed incrementally in stages. It maps out a path for interdependent renovations to enable the recommended master plan. A general time line is suggested along with probable developmental costs.

This chapter includes the following sections:

- 8.1 Phasing Options and Logic
- 8.2 Cost Implications
- 8.3 Conclusions

## 8.1 PHASING OPTIONS AND LOGIC

It is clear that the Du Bois building must remain occupied and functioning while the master plan is implemented. Many of the changes that are envisioned will require renovating the building systems to bring it into building code compliance. Thus the construction and the expenditure of funds will need to be coordinated over time to make sure each step has been preceded by all the necessary changes that will enable the next step to be made.

A key enabler for many of the renovation projects will be moving portions of the print collections into storage. The following two pages outline a spectrum of options for that, both short and long term. The master plan recommends fitting out portions of the Du Bois basement short term, in combination with negotiation with the Five College Consortium to find a way to expand the shared Depository.

The phasing diagram and table which follows divides the project into phases that roughly follow each other in a time line from 2011 to 2023. The leading category for each phase is a description of the enabling event that will allow the construction event to happen. Like a chess game, the schedule unfolds as one space is vacated, then it is renovated, then the new use moves in, vacating yet another space for renovation.

Once the short term projects are completed, there are a number of mid- to long-term projects that could be done in any sequence, either independently or simultaneously, because they would involve taking an underutilized closed carrel floor and converting it. The phasing diagram indicates linked logical sequences for renovation.

In each phase, renovation or moving tasks are identified and assigned a cost. These costs are summed and a running total of cost is kept of the total cost of the project. These costs have been established based on fairly general understanding of the type of construction needed, its place within the tower and the time when it will be constructed. A record of the method of each cost and how it was arrived at is provided in the Appendix.

It should be emphasized that this particular scenario of unfolding events, while logical, may in fact not be how the various projects may develop. If this turns out to be the case the instructions for revising the costs of any particular construction event are also included in the Appendix so that a new set of scenarios with new dates and enabling events may be constructed easily. An example of how to use the information is included as an aid.



# ENABLING PROJECTS

## ON-CAMPUS OPTIONS FOR COLLECTIONS STORAGE

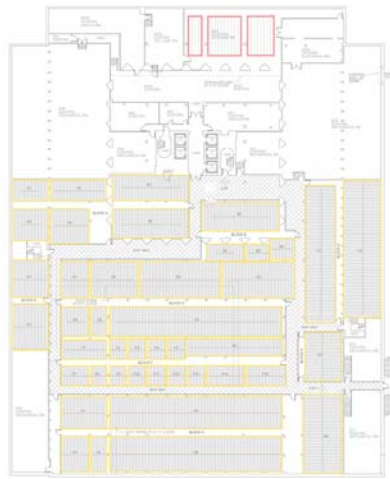

### **Renovate Du Bois Basement - Compact Shelving:**

Conversion of former storage space into compact shelving, enabled by some relocation of utility lines and upgraded environmental control systems. Partitioning at new corridors will allow incremental renovation as needed. Advantage of direct elevator access.

Est'd cost: **\$14.2 million (\$388/SF)**  
 Est'd capacity: 100,000 LF (5 shelves high)  
 Area: 36,604 SF  
 Fitup costs (TPC): \$9.6 million  
 Compact shelving costs: \$4.4 million  
 Book relocation costs: \$215,000



### **Renovate Goodell First Floor - Compact Shelving:**

Installation of compact shelving at on-grade structure. (Can also retain existing shelving on Second Floor currently used by Univ. Archives.) Advantage of existing loading dock for materials handling.

Est'd cost: **\$3.1 million (\$317/SF)**  
 Est'd capacity: 28,500 LF (5 shelves high)  
 Area: 9865 SF  
 Fitup costs (TPC): \$1.4 million  
 Compact shelving costs: \$1.7 million  
 Book relocation costs: \$83,000



### **Construction of Underground Storage Facility between Du Bois and Goodell Buildings - Compact Shelving:**

Could be concealed with landscaping above and designed for reader access if desirable. Advantage of connection to both buildings.

Est'd cost: **\$35.0 mil (\$499/SF)**  
 Est'd capacity: 196,000 LF (7 shelves)  
 Area: 35,000 SF  
 Fitup costs (TPC): \$29.0 million  
 Compact shelving costs: \$6.9 million  
 Book relocation costs: \$357,000

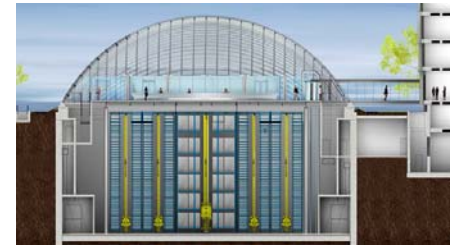

Example: Univ. of Chicago Mansueto Library

### **Construction of New Storage Facility on campus – High Density:**

New construction on UMass Amherst owned property for long term high density storage, either above or below ground. Could be Harvard type or automated retrieval system. Reduced carbon footprint.

Est'd cost: na/requires study

# ENABLING PROJECTS

## OFF-SITE OPTIONS FOR COLLECTIONS STORAGE



### **Expansion of Existing Five College Depository - High Density Storage:**

Currently under study. Desirable solution but requires negotiation among Five College Consortium and may encounter other unknown issues. Original adaptive reuse was designed for 500,000 vol. of which 250,000 vol. was UMA share; currently at 80% capacity.

*Est'd Cost:* New structure could range between \$3 million to \$6 million for new high density facility storing 1 to 2 million volumes (per 10/19/10 preliminary study provided by UML).



### **Build New Depository Off Campus - High Density Storage:**

If expansion of the Five College Depository did not go ahead, UMass could chose to build a depository for the UMass library system, as the primary public research library serving the region.

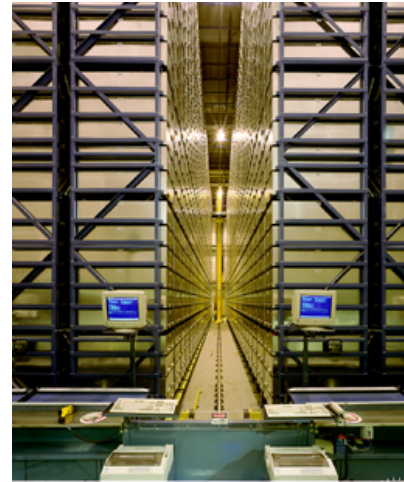

### **Build New Five College Depository Off Campus - High Density with Automated Retrieval System:**

UMass could work with the Consortium to promote development and construction of a new facility for the Five College Depository, one that took advantage of the latest technologies in automated retrieval systems.

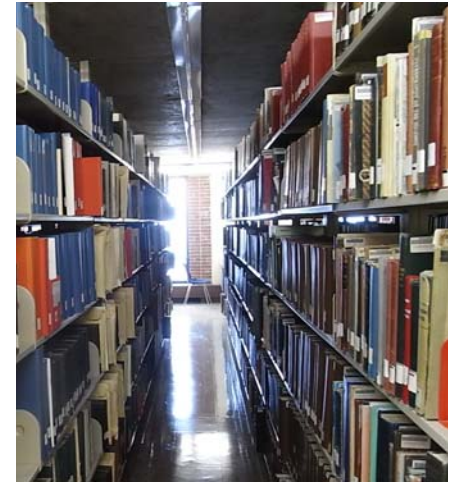

### **Rented Local Building (temporary) - Regular Shelving:**

This is perhaps the least desirable solution as it will require initial investment in fitting up a leased space with stacks and appropriate environmental controls, yet not provide the long term benefits, density or efficiencies of operation of the Five College Consortium.

# PROPOSED PHASING SUMMARY

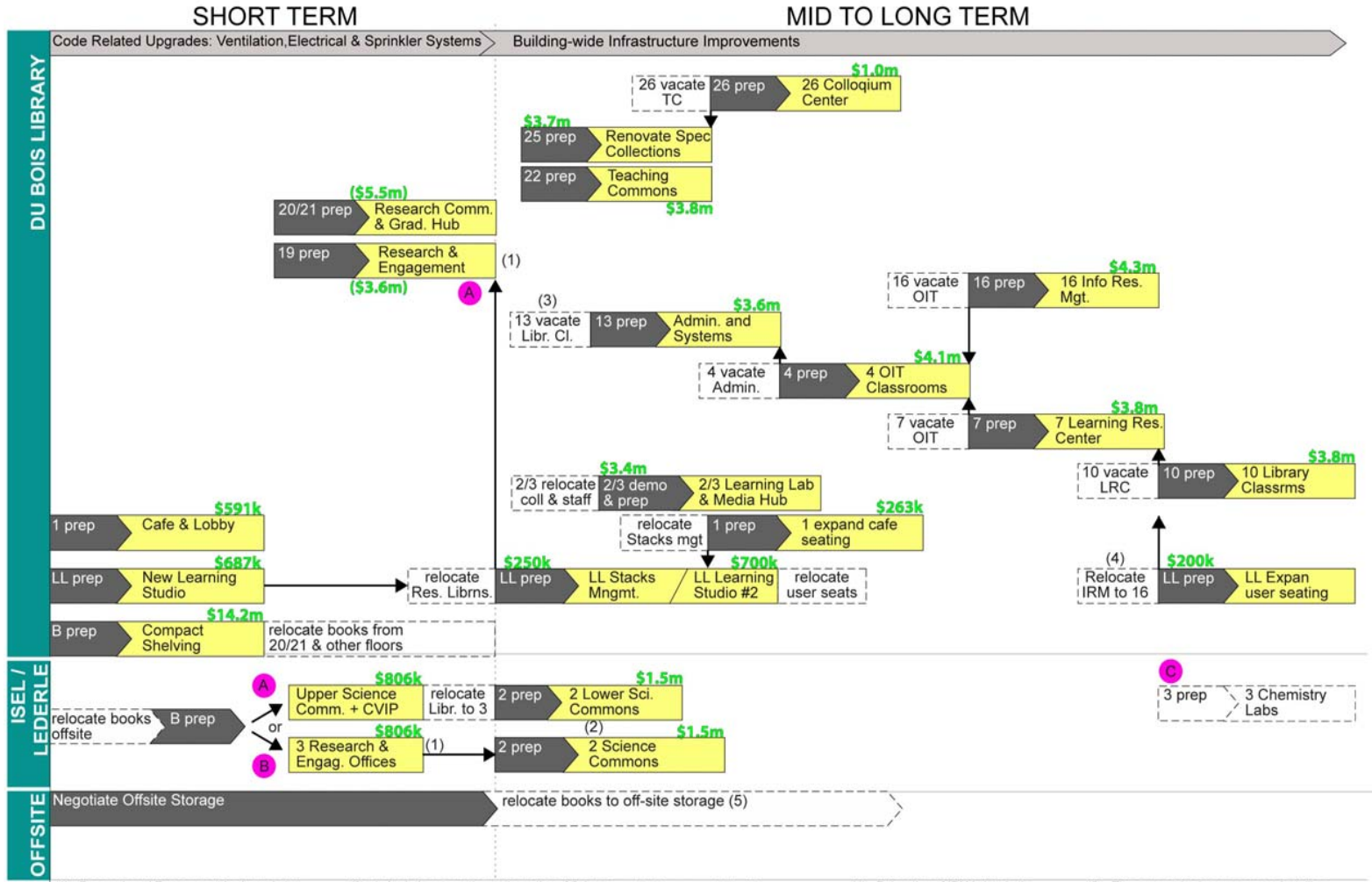

(1) - Research and Engagement is shown in two alternative locations: (Du Bois 19 or Lederle 3). In short term phase because of urgency as institutional priority. Research Commons on 20/21 also shown in short term because it is high on both R&E and Library priorities and replaces quiet seating lost with carrel demolition, becomes symbol of progress.

● = OPTIONS    \$ = total project cost

(2) - In Lederle, renovation and creation of Science Commons becomes more drawn out when librarians need to continue to operate out of the space. (By comparison, if the 3rd floor becomes CVIP plus commons seating, then library operations could move up there temporarily while the 2nd floor gets renovated.)

(3) - Assumes existing library classrooms can be demo-ed once new learning studios on LL are fitted out, if those can be used for library classes temporarily. Science Commons by that point can also provide a replacement library classroom.

(4) - Relocation of IRM is late in the sequence because they have only recently been moved and there is the possibility they might end up elsewhere, perhaps Goodell or off campus if the Five College Consortium merges their technical services groups in the future.

(5) - The proposed scheme assumes installing compact shelving in Du Bois basement rather than Goodell basement because of efficiency of direct elevator access. If the negotiations for the expansion of the Five College Depository do not conclude in sufficient time, Goodell basement becomes a midterm phase fall back.



# PHASING OPTIONS AND LOGIC

## SHORT TERM

	Current		Short Term (3 Years)	
<b>Enabling Projects</b>	Infrastructure Improvements Elevators, Lobby Doors Prepare Du Bois Basement	Install shelving in basement Move books to basement	Relocate books from 21/22 in Tower to basement storage	Install sprinkler system in tower, provide stair pressurization system and emergency electrical system in Du Bois
<b>Du Bois Library</b>	Relocate staff functions into lower level  Build Learning Studio in Lower Level  Move Café away from Main Entry	Repurpose vacated space on upper levels to user space Use half 3 <sup>rd</sup> level for user study Use 6 <sup>th</sup> level for new user or swing space Store newly acquired collection in Government area or basement Use basement for shifting collections off site Expand Commons to new Café area	Provide new Learning Commons Space at 1 <sup>st</sup> Level adjacent to new café  Construct 2 <sup>nd</sup> Learning Studio at southeast corner of Lower Level	Accommodate construction activity in tower for new HVAC, sprinklers and electrical upgrades.
<b>Lederle ISEL</b>	Build basement compact shelving  Reorganize and consolidate collections	Fit up Science Commons at 3 <sup>rd</sup> Floor Build New Café at 2 <sup>nd</sup> Floor  Reorganize and consolidate collections	Fit up 3 <sup>rd</sup> Floor areas for CVIP, War Room and Access Grid Room  Reorganize and consolidate collections	Fit up 2 <sup>nd</sup> Floor for Science Commons Collaborative Work Zone and Teaching Lab
<b>Task Costs</b>	Elevator Rehab Project \$ 4.7 M Du Bois Basement Prep \$ 9.4 M New Café Expansion \$ 500 K Learning Studio \$ 687 K Lederle Compact Shelves \$250 K	Install Basement Shelving \$ 4.8 M Repurpose Vacated Space \$ 100 K Move Stacks Man Group \$ 100 K Lederle Commons Fit Up \$ 913 K Lederle Café Construction \$ 250 K	Expand LC next to Café \$ 245 K 2 <sup>nd</sup> Learning Studio \$ 700 K Lederle 3 <sup>rd</sup> Floor fit up \$ 806 K Book Relocation \$ 74 K	Sprinkler Installation \$ 1.9M HVAC Upgrades \$ ? Electrical up-grade \$ 7.6M Lederle 2 <sup>nd</sup> Floor fit up \$ 1.5M
<b>Ph Total \$</b>	\$ 15.3 M	\$ 6.2 M	\$ 1.8M	\$ 11.0M
<b>Running \$</b>	\$ 15.3 M	\$ 21.5 M	\$ 23.3M	\$ 34.3M
<b>Time Line</b>	Completion 2010 - 2012	Completion 2011 - 2013	Completion 2012 - 2013	Start 2011 and Complete 2014

Notes: Costs are Total Project Costs (TPC)    Costs in Red are Funded    Costs in Blue are Planned but not Funded

# PHASING OPTIONS AND LOGIC MID TO LONG TERM

	Mid to Long Term			
<b>Enabling Projects</b>	Relocate Library Offices from 19 <sup>th</sup> Floor	Relocate books from 20 <sup>th</sup> and 21 <sup>st</sup> level to other floors, sort at basement or off-site storage	Vacate Library Classrooms (to learning studios)	Vacate 4 <sup>th</sup> Floor
<b>Du Bois Library</b>	Renovate 2/3 levels into demonstration teaching spaces and media hub  Make improvements to Special Collections, expand to full floor stack capacity  Renovate 25 <sup>th</sup> Level for special Collections	Convert 19 <sup>th</sup> carrel floor to Research and Engagement Center  Renovate 20 <sup>th</sup> and 21 <sup>st</sup> levels for Research Commons and Graduate Hub	Renovate 22 <sup>nd</sup> carrel floor for Teaching Commons  Renovate 13 <sup>th</sup> floor new administration systems and new server room  Perimeter Carrel Upgrades on multiple floors	Convert 26 <sup>th</sup> floor to Colloquium space  Renovate 4 <sup>th</sup> Level for OIT tech classrooms and additional learning commons classrooms
<b>Lederle ISEL</b>				
<b>Costs</b>	Renovate Level 2 & 3 \$ 3.3 M Spec. Collections Stacks \$ 31 K Special Collections Reno \$ 3.7 M	Book Relocation \$ 74 K Research Commons \$ 5.9 M Relocate Lib. Offices \$ 50 K Research and Engmt \$ 3.7 M	Teaching Commons \$ 3.8 M Renovate 13 <sup>th</sup> Floor \$ 3.6 M Server Upgrade \$ 600 K Perimeter Carrels \$ 350 K	Colloquium Space \$ 750 K Renovate 4 <sup>th</sup> Level \$ 3.7 M
<b>Ph Total \$</b>	\$ 7.0 M	\$ 9.7 M	\$ 8.4 M	\$ 4.4 M
<b>Running \$</b>	\$ 41.3 M	\$ 51.7 M	\$ 59.4 M	\$ 63.9 M
<b>Time Line</b>	Start 2013 and Complete 2016	Start 2015 and Complete 2016	Start 2015 and Complete 2016	Start 2016 – Complete 2017

Notes: Costs are Total Project Costs (TPC)    Costs in **Red** are Funded    Costs in **Blue** are Planned but not Funded

# PHASING OPTIONS AND LOGIC MID TO LONG TERM

	Mid to Long Term		
<b>Enabling Projects</b>	Vacate 7 <sup>th</sup> Floor	Vacate 10 <sup>th</sup> Floor	Vacate 16 <sup>th</sup> Floor
<b>Dubois Library</b>	Remove carrels and renovate 7 <sup>th</sup> floor for LRC  Renovate part of Level 18 for Quiet Study	Remove carrels on 10 <sup>th</sup> floor and renovate for additional library classrooms	Renovate 16 <sup>th</sup> floor for Information Resources Management and relocate from Level 4
<b>Lederle ISEL</b>			
<b>Costs</b>	7 <sup>th</sup> Level Renovation \$ 3.9 M Quiet Study Area \$ 150 K	10 <sup>th</sup> Level Renovation \$ 4.1 M	16 <sup>th</sup> Level Renovation \$ 4.3 M
<b>Ph Total \$</b>	\$3.9 M	\$ 4.1 M	\$ 4.3 M
<b>Running \$</b>	\$ 67.8 M	\$ 71.9 M	\$ 76.2 M
<b>Time Line</b>	Completion 2016	Start 2017 and Complete 2019	Start 2019 and Complete 2020

Notes: Costs are Total Project Costs (TPC)    Costs in **Red** are Funded    Costs in **Blue** are Planned but not Funded



## 8.2 COST IMPLICATIONS

Much of this study has been directed at how to develop a Library plan for the future that can be implemented in a changing university landscape. Even as the study was being undertaken, new priorities began to appear and new questions proposed.

In Section 3 of this report “opportunities” were discussed in light of understanding the “kit of parts” that was available to future architects and planners in thinking about the library. These “opportunities” range from how various floors can be reconfigured to how can storage in the library be shifted to alternative locations to make room for other opportunities. Key to making decisions about these “opportunities” was to know how much they might cost to implement. Good ideas are only good if they make sense financially. The calculations of the costs are presented in table form in the Appendix with instructions on how to recalculate costs should different alternatives be considered.

On the following pages the “options” are summarized as a group so as to be quickly accessible. In the preceding phasing schedule some of these options have been used as part of the proposed implementation. Some have not and remain available for selection should consideration of other alternatives become necessary. If more information is needed about any of them, the reader should return to Section 3 for a more complete explanation.

It should be noted that the costs that have been presented for these “options” are done in today’s dollars. They are shown in total project cost (TPC) including consultant fees, FF&E and campus management costs. Ancillary costs such as moving costs, ongoing servicing costs or changes in labor costs are not included. Position of the construction within the building or elsewhere on the campus will be important to analyze as options are reviewed.

# COMPARATIVE COSTS DU BOIS OPTIONS

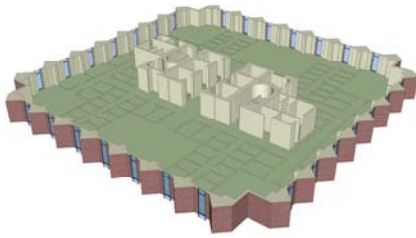

### **Convert Typical Enclosed Carrel Floor:**

Remove interior partitioning and fit out for a variety of functions. Best option for adequate ceiling height for air distribution to enclosed workspaces. Master Plan proposes converting these underutilized floors.

For this example we are assuming the work is done at the one of the upper levels. The Total Project Cost (TPC) would be: **\$3.2 Million (\$310/SF)**

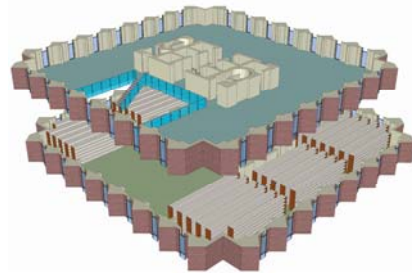

### **Convert Top Floor of Typical Stack Pair:**

Remove upper stacks to fit out for open seating, but retain slab supported by stacks below. Ceiling height is very limited. An opening in the floor can create a double height special room, but stacks would surround it.

Because this option does not re-purpose much of the lower floor which remains as stacks it has a relatively low cost on a per square foot basis:  
TPC: **\$3.4 Million (\$162/SF)**

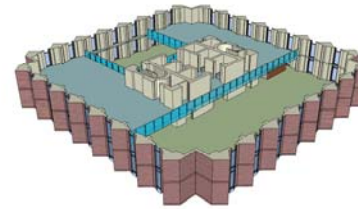

### **Remove Two Stack Floors and Restructure a New Steel Supported Floor:**

Useful for new functions that require high ceilings for sight-lines, such as proposed for 20/21<sup>st</sup> floors to create Research Commons with proper infrastructure for 21<sup>st</sup> floor slab.

This option creates more large open high areas but lowers the total available usable area by 25% on the two floors.  
TPC **\$5.3 million (\$346/SF)**

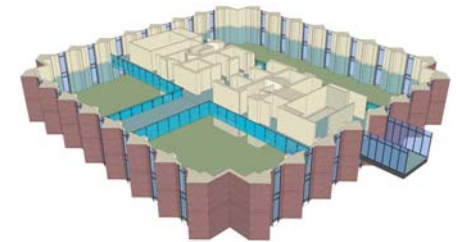

### **Remove Portions of an Existing Steel Supported Floor:**

The existing 3<sup>rd</sup> and 6<sup>th</sup> floors are supported with steel. This would make it relatively easy to take out the floor and create double height spaces. This has been proposed for the 3<sup>rd</sup> and 4<sup>th</sup> floors to become the Media Hub and Learning Lab.

Because this option only has to remove sections of the floor and not rebuild them the Total Project Cost (TPC) would be: **\$3.4 Million (\$261/SF)**

# COMPARATIVE COSTS

## NEW CONSTRUCTION OPTIONS

Options to expand the Du Bois building to provide more teaching space combined with more informal study space were explored. These options offer the advantage of not impacting ongoing library operations as severely, because new construction activity can be more isolated, and the new addition can help reinforce the academic center of the campus around the pond, relating to the student center activity and a future academic building to the north.

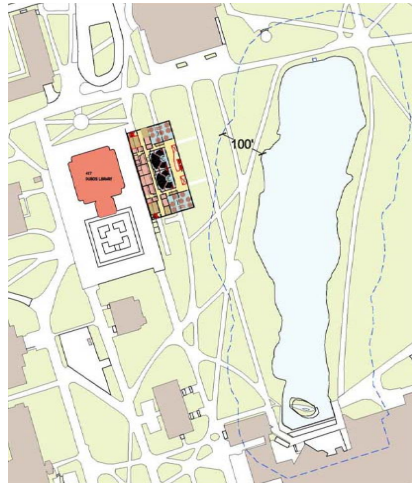

### **Addition to Du Bois Lower Level:**

This new construction option would develop a new classroom building addition at the edge of the Lower Level Learning Commons opening out towards the Pond. It would exploit potential synergies of connection to the Learning Commons for learning support and collaborative study.

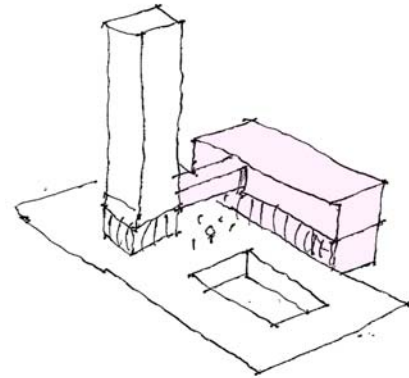

### **Addition Building at Plaza:**

This option could be a larger structure rising above plaza level to animate plaza more effectively and connect to Du Bois near the existing open stair, to encourage walk-up circulation between Learning Commons and classrooms. Security envelope issues would have to be addressed.

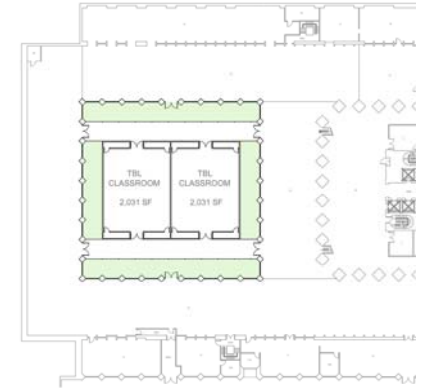

### **Capturing Courtyard:**

Fairly expensive for the space gained, this would only create two classrooms and greatly reduce the garden amenity, natural light and views for users that make the Learning Commons successful, and potentially making orientation in the complex harder. The rooftop would need careful landscaping which adds cost. This option is not recommended. A preliminary estimate projects a TPC of \$4.49 million (\$358/SF)

## 8.3 CONCLUSIONS

The master plan has laid out a number of options for converting library space to other university functions compatible with the library mission. Compatible use functions are already present in Du Bois space, but the amount of space allocated to compatible uses has been increased by 65% with the master plan. The proposed master plan is compatible with the Library's vision for the services and facilities for the next decade.

The process of planning over the next decade will require coordination between these potential uses, the library and the other University development projects and planning initiatives underway, particularly the process for developing a Campus Master Plan and refining the Academic Space Plan and Science & Engineering Facilities Plan.

In situations where there is pressure to convert space to uses which are not compatible with the library mission, such as the conversion of Science & Engineering Library space into Chemistry labs, then care needs to be taken to replace lost seating and essential library services support in other locations that do not compromise library function.

A careful planning process is needed to navigate through these initiatives so that the best solution can be developed to optimize all requirements in the interest of the campus and the library.

Recommendations for next phase of study:

### **Feasibility and cost of expansion of the Five College**

**Depository:** This key enabling project will determine a lot of decisions about construction needed on campus.

### **Extent of general use classrooms needed in Du Bois:**

This study was done in the context of uncertainty as to when the proposed academic building might move forward, so opportunities were sought to find space for new types of classrooms. If that situation changes, the allocation of space to other functions might be revisited and increased, e.g. for work with media resources or other growing needs.

**Seating analysis:** Depending on what decisions are made about how to repurpose space, the distribution of seating should be revisited to confirm that there will be adequate study seating to meet future demand.

**Building addition at plaza:** The option of building adjacent to Du Bois would be of great benefit to the campus. Locating a new building here could provide activity at the water's edge and a new potential entrance into the library at the Learning Commons level. The potential for this site should be studied whether or not the proposed academic building moves forward.