

1932

# Studies on the effect of different temperature gradients as produced under three brooder stoves upon body weight, feathering and sleeping groups of chicks during two period of brooding

John V. Strickland

*University of Massachusetts Amherst*

Follow this and additional works at: <https://scholarworks.umass.edu/theses>

---

Strickland, John V., "Studies on the effect of different temperature gradients as produced under three brooder stoves upon body weight, feathering and sleeping groups of chicks during two period of brooding" (1932). *Masters Theses 1911 - February 2014*. 2012.

Retrieved from <https://scholarworks.umass.edu/theses/2012>

This thesis is brought to you for free and open access by ScholarWorks@UMass Amherst. It has been accepted for inclusion in Masters Theses 1911 - February 2014 by an authorized administrator of ScholarWorks@UMass Amherst. For more information, please contact [scholarworks@library.umass.edu](mailto:scholarworks@library.umass.edu).

UMASS/AMHERST  
312066 0306 8585 7

FIVE COLLEGE  
DEPOSITORY

STUDIES ON THE EFFECT OF DIFFERENT  
TEMPERATURE GRADIENTS AS PRODUCED UNDER  
THREE BROODER STOVES UPON BODY WEIGHT,  
FEATHERING AND SLEEPING GROUPS OF CHICKS  
DURING TWO PERIODS OF BROODING

STRICKLAND - 1932

This thesis is not to be loaned  
outside the library building. For this  
purpose, use the copy in the department  
where the work of the thesis was done.

ARCHIVES  
THESIS

M  
1932  
S917



UNIVERSITY OF MASSACHUSETTS  
LIBRARY

---

M  
1932  
S917

Archives Thesis

---

This thesis is not to be loaned outside the library building. For this purpose, use the copy in the department where the work of the thesis was done.

STUDIES ON THE EFFECT OF DIFFERENT TEMPERATURE  
GRADIENTS AS PRODUCED UNDER THREE BROODER STOVES  
UPON BODY WEIGHT, FEATHERING AND SLEEPING GROUPS  
OF CHICKS DURING TWO PERIODS OF BROODING.

By

John V. Strickland

THESIS SUBMITTED FOR DEGREE OF MASTER OF SCIENCE

Massachusetts State College  
Amherst, Mass.

1932

## ACKNOWLEDGEMENT

This investigation was conducted under the direction of Professor W. C. Sanctuary, whose criticism and suggestions are gratefully acknowledged. The author wishes to acknowledge also the constant interest and encouragement of Professor J. C. Graham, Head of the Poultry Department, and Dr. F. A. Hays for suggestions as to statistical procedure. Mr. Costas Nicolaidis rendered valuable assistance in carrying through a large part of the computation.

## C O N T E N T S

	Page
INTRODUCTION	1
REVIEW OF LITERATURE	2
1. Weights of Rhode Island Red chicks at various ages	2
Weight at one week of age	3
Weight at two weeks of age	4
Weight at three weeks of age	4
Weight at four weeks of age	4
Feathering	6
Temperature	6
GENERAL SET UP AND PROCEDURE	9
Temperature gradient defined	11
Chicks used	12
Collection of data	12
RESULTS OF TREATMENT	14
Body weight	14
Differences at one week of age	15
Differences at two weeks of age	15
Differences at three weeks of age	16
Differences at four weeks of age	17

FEATHER DEVELOPMENT	17
Feathering at the end of third week	17
Feathering at the end of fourth week	18
TEMPERATURE AND TEMPERATURE GRADIENTS	21
Relation of mean temperature to size of optimum belt	23
MORTALITY	26
Mortality record for brood I	26
Mortality record for brood II	28
SLEEPING HABITS OF CHICKS	29
SUMMARY	35
BIBLIOGRAPHY	



## INTRODUCTION

The importance of heat in the rearing of chicks is well known but very little is known of the effect of heat on the rate of body growth and feather development. Investigators have given little consideration to temperature in their efforts to solve the rearing problems. A study dealing with methods of heat distribution and control should throw some light on our present brooding problem.

The purposes of this study are:

1. To determine the temperature gradient produced by the brooder stoves in three houses, two of them modified to produce different conditions.
2. To determine room temperatures and humidities in colony houses as affected by three methods of heat distribution and control.
3. To determine the effects of the several varying temperature gradients and the associated physical conditions upon the

comfort, weight and feather development of chicks.

4. To observe the sleeping chicks to determine location, mass movements or crowding.

#### REVIEW OF LITERATURE

The literature reveals no studies of this specific nature. However, it might be well to cite related work.

1. Weight of Rhode Island Red Chicks at various ages.

Day-old weight. -- Card and Kirkpatrick (1918 reported the mean weight of chicks when hatched to be 37.20 grams. Jull and Quinn presented records on 228 chicks. They found the average day-old weight to be 38.34 grams. Their mean weight records agree closely with those recorded in this study. Jull and Titus (1928) reported the mean day-old weight on 157 chicks that were obtained by mating Rhode Island Red males to Barred Plymouth Rock females. They found the average weight to be 38.34 grams.

Upp (1928) found the mean weight of 1858 chicks at hatching time to be 37.70 grams.

Hays and Sanborn (1929) found the average day-old weight of 1329 chicks to be 36.7 grams. Their records

covered six years.

The chicks used in this study averaged a little more than those reported by other investigators. This high mean day-old weight might be due to the fact that this College is breeding for large egg size. Egg size has been shown by a number of workers to be intimately correlated with the size of the chick hatched. Benjamin (1920) presented data to prove that chick size at hatching time depends upon the size of the egg. Halherschlen and Musschl (1922) found that the weight of day-old chicks averaged 64 per cent of the egg weight. Jull and Quinn (1928) reported that Rhode Island Red day-old chicks averaged 66.06 per cent of the weight of the egg. Upp (1928) found that Rhode Island Red chicks averaged 68 per cent of the weight of the egg hatched. Hays and Sanborn (1929) reported that chicks averaged 61.00 per cent of the weight of the egg from which they were hatched.

Weight at one week of age.-- Data on Rhode Island Red week-old chicks are scarce. For some reason investigators have given very little attention to recording the weight of chicks at this age. Card and Kirkpatrick (1918) found the average weight of 858 one-week old chicks to be 52.16 grams. Kaupp (1921) gives the average weight

of several hundred chicks at one week of age to be 45.40 grams. These weights fall below the one week mean weight of the lots of chicks treated in this experiment.

Weight at two weeks of age. -- Card and Kirkpatrick (1918) found 73.48 grams to be the mean two week weight for 789 individuals. Kaupp (1921) gave the average weight at two weeks as 72.48 grams. Upp (1928) reported data on 1858 chicks when two weeks old. He gave the mean weight as 60.69 grams. Jull and Titus (1928) found the mean weight of 156 chicks at two weeks to be 82.0 grams. Hays and Sanborn (1929) reported the two-week mean weight on 857 Rhode Island Red Chicks to be 87.9 grams.

Weight at three weeks of age. -- Data on Rhode Island Red chicks at this age are very limited. Card and Kirkpatrick (1918) found the average weight on 750 Rhode Island Red chicks to be 119.7 grams. Kaupp (1921) gave the mean three-weeks weight on several hundred individuals as 127.0 grams. The three-week weights thus far reported for Rhode Island Reds fall below those obtained in this study.

Weight at four weeks of age. -- Card and Kirkpatrick (1918) found 165.11 grams to be the average weight at four weeks for 714 chicks. The authors were of the



opinion that the weekly weighing retarded the rate of growth. Knapp (1921) reported the mean weight of several hundred chicks to be 185.98 grams. Upp presented data on 1581 chicks at four weeks of age. He gave the mean weight as 115.63. The strain used by Upp apparently did not come up to the standard weight for Rhode Island Reds.

Jull and Titus (1928) presented records on 155 chicks that came from a cross of Rhode Island Red males and Barred Plymouth Rock females. The mean four-week weight was 205 grams. Heterosis probably accounted for this increase in weight over the weight obtained by the other investigators.

Hays and Sanborn (1929) found the mean weight of 17868 Rhode Island Red chicks to be 214.1 grams. Their records covered a period of eleven years. They reported yearly mean weight at four weeks of age ranging from 183.0 to 255.2 grams.

These data on chick weights are cited only to show what should be expected of Rhode Island Red chicks during the first four weeks of their existence. From the weights reported one can readily see the wide variation in the rate of growth at the various ages. No doubt such factors as management, strain of chickens and climatic conditions account for these variations.

### FEATHERING

Bittenbender (1930) stated that feather growth is heavier when humidity is high. Arndt (1931) said that humidity assists in the amount of feathering that a bird develops. He recommended a humidity range between 33 and 40 per cent. Messier (1931) while discussing battery brooding, stated that there is a direct correlation between humidity and feather development. Card (1923) published an article on "How the chick gets his clothes". In this article he has the following to say about feathering:

"It often happens that chickens fail to feather normally because of unfavorable rearing conditions. Feather growth is greatly retarded when chickens are crowded in the brooder with little ventilation, on the other hand chicks that are kept in quarters that provide ample ventilation at all times feather out quickly and smoothly and make a more uniform appearance."

### TEMPERATURE

Lewis (1911) conducted an experiment for the purpose of discovering the best brooder temperature. After running brooders at various temperatures for 28 days he recommended a temperature of 100 degrees for the first

week, 98 degrees for the second, 92 degrees for the third, 88 degrees for the fourth and then a gradual reduction until no more heat is required.

Lewis' study was made during the month of May and it is quite evident that his recommendation was for that month.

Snyth (1927) has the following to say about temperature for brooding chicks:

"The temperature at the edge of the hover an inch from the floor should be 98 to 100 degrees at the start and be decreased about five degrees per week, until the chicks are large enough to do without heat. The temperature in the brooder room should be such that the chicks will be comfortable in any part of the room but warm enough to settle down only at the edge of the hover. The behavior of the chicks is the best guide as to heat requirement. During the day the chicks should be comfortable in any part of the brooder house and at night remain in a circle around the outer edge of the hover."

Thompson and Clinkner (1927) suggested a hover temperature of 100 degrees at the start dropping it to 95 toward the end of the first week. Moses and Woods (1927), in the case of an electric brooder, suggested a temperature of 90 to 95 degrees two inches above the floor and five inches inside the outer edge of the hover under all weather conditions. Bittenbender, Witkins, Vernon and Whitfield (1929) said that the temperature should vary in



accordance with the weather and the number of chicks being brooded. They suggested a temperature of 90 to 95 degrees at the start at a point directly below the outside of the deflector and about two inches above the floor. They also suggested that the temperature be reduced two or three degrees per week if the weather permits.

Jull (1930) said that it is impracticable to state the temperature at which brooders of each type should be kept. He states that the best temperature at which to keep the brooder depends on the position of the thermometer, the type of hover, the age of the chicks and the weather conditions. However, he suggested a temperature of 100 degrees at the start.

The temperature under the hover and within the room are affected much by the direction and velocity of the wind. The direction and velocity of the wind determine to what extent the chicks will spread out around the edge of the hover.

Kelly (1930) has shown that when the velocity of the wind exceeds ten miles per hour it is a dominant factor in the amount of air passing through a farm building.

Observations made by Sanctuary (1930) showed a variation in temperature of 18 degrees at the hover's edge. Under such conditions it would be impossible for chicks



to form a complete circle around the hover. Some areas would be too cold and others too hot.

#### GENERAL SET-UP AND PROCEDURE

Three 10 x 12 colony brooder houses of the type used on the Massachusetts Agricultural Experiment Station Farm were equipped with the same size and make of coal burning brooder stoves. This equipment, both with respect to colony houses and type of heating units used, is typical of that used on the average New England poultry farm.

The control lot of chicks was brooded in a house containing one of the coal burning brooder stoves, unmodified except for a cotton cloth hover curtain hanging from the hover's edge to within three inches of the litter. This curtain was used to conserve some of the heat radiated by the stove (Fig. 1-a and 1-b). The second lot of chicks was brooded under a stove, a duplicate of that in Control house, (Fig. 2-a and 2-b) including the hover edge curtain. This stove was equipped with a metal shield of cylindrical form, similar in shape and function to that around a hot air furnace, which was so placed as to allow a space of one inch between it and the stove. Placing the shield close to the radiating surface of the stove causes a rapid upward direction of air back of the shield where the supply

of new air is provided by an ordinary stove pipe (Fig 2-a and 2-b) extending from the vertical wall of the shield to a point eight inches beyond the hover's edge. This arrangement of shield and pipe reverses the usual direction of the air under the hover from that of incoming cool air to that of outgoing warm air. The shield also reduces the amount of radiant heat directed upon the chicks, substituting for it a certain amount of convectional heat.

The third lot of chicks was brooded under a stove, the duplicate of those in the first and second houses. No hover edge curtain and no shield device were used in this case. This stove was surrounded by a muslin curtain hanging from the ceiling of the house at a distance of eighteen inches from the hover's edge and within three inches of the litter on the floor (Fig. 3-a and 3-b), except for fifty-two inches on the south side between the stove and the front ventilation openings, where that section extended clear to the floor to cut off cold floor drafts from the front openings. The curtain fitted snugly to the ceiling permitting little or no circulation of air over the top of it. The purpose of the curtain was to provide warm sleeping quarters inside of the curtain and

a cool exercising area outside. Because of the retention of heat within the area surrounded by the curtain it was hoped to be able to maintain a less intense fire and a modified temperature gradient.

Temperature Gradient Defined. -- Temperature gradient, as the term is used in this paper means the rise in temperature per inch from any outside point toward the source of heat.

It is obtained by means of a temperature gradient meter which consists of a yard stick to which tested thermometers with naked bulbs are attached every three inches. In obtaining the temperature gradient on a given side of a brooder stove, the temperature gradient meter is laid on the litter, extending from the base of the stove to a point thirty-three inches away which is 15 inches from the hover's edge and invariably includes all the sleeping area used by the chicks.

It is obvious that the greater the temperature gradient, that is, the more rapid the rise of the temperature for a given linear distance, the smaller will be the area in which the chicks can sleep comfortably.

Thermometers hung on the studs of the south and north walls three inches above the litter recorded the room



temperature at those points. Thermometers were also attached to the south and north edge of each hover, extending to within three inches of the litter on the floor. A thermograph at the north edge of each hover recorded the daily fluctuations of temperature at those points.

#### CHICKS USED

Chicks from the College Plant, consisting of Rhode Island Reds, Barred Plymouth Rocks and White Leghorns made up both broods.

The first brood was put in the houses March 3, the second March 31. One hundred and sixteen chicks made up each lot of the first brood; one hundred and fourteen chicks were placed in each house for the second brood.

The management of the three lots was uniform. The baby chick ration recommended by the Agricultural Experiment Station of New England was fed to each lot. No lights were used on either brood.

#### COLLECTION OF DATA

Temperature gradients were taken daily between 7 and 8 a.m. and 5 and 6 p.m. on the south and north sides of

the stoves. The readings of all the thermometers in each house were recorded when the gradients were taken. From time to time observations on sleeping habits were made. Most of these were made from 10 to 12 p.m.

Humidity readings were taken only twice each week. The readings were taken in all houses at the same hour. A sling psychrometer was employed for obtaining the relative humidity readings.

The chicks were taken from the incubator in the afternoon, legbanded and weighed individually. The following morning they were put in the houses and considered one day old. Then, at intervals of seven days they were weighed and studied for feathering.

Only eight parts of the body were considered in this phase of the study.

The parts of the body studied for feathering were (1) tail, (2) shoulder, (3) breast, (4) thigh, (5) ischium, (6) keel, (7) back and (8) wing cord. Each section was given a value of 12.50 per cent. Before the end of the study it was discovered that the parts selected do not give a complete picture of feathering.

Although three breeds were represented in the houses,

data presented on growth and feathering are only for the Rhode Island Reds: Mortality records cover the three breeds.

## RESULTS OF TREATMENTS

### BODY WEIGHT

Data obtained on body weight for both broods are shown in Tables 1 to 6. The results of the three treatments as tested by treating the differences in the means are presented in Table 7. The range, standard deviation and probable error for the mean and standard deviation were determined. For testing the significance of difference in the means the method devised by Engledow and Yule (1926) and illustrated by Hays (1932) was used. The final equation is given below.

$$\sigma^2 d = \frac{2m}{m-1} (\sigma_t^2 - \sigma_y^2)$$

In the above equation  $d$  = desired difference in the body weight under the different heat treatments taking into account the different responses of each experimental period:  $m$  = number of different houses or heat treatments; in this case three:  $\sigma_t$  is the standard deviation



for the three different treatments and  $\sigma_y$  is the standard deviation of means of the three experimental periods.

Differences at Hatching time. -- The significance of the differences in the means for weight at hatching was not determined because the weights at this period were not influenced by the treatments, however, it might be well to point out what records for this period show.

For Brood I, the ranges and the means for body weights were approximately the same for all houses, however, the control showed the greatest amount of variation. The situation for Brood II was about the same as found in Brood I.

Differences at one week.--- At the end of this period the chicks in the curtain and shield houses gave larger mean weights than those in the control house (Table 7). The differences in the means can not be considered significant. The greatest amount of variation was still found in the control lots. The curt in lot has the least range for Brood I.

The differences in the extent of ranges were negligible in Brood II.

Differences at two weeks.--- The ranges for Brood I

were approximately the same for all lots. In Brood II the shield lot gave a range that exceeded the ranges for the other houses. The control lot gave the greatest amount of variation for Brood I and the greatest per cent of variation for Brood II was found in the shield house.

The chicks in the curtain and shield houses grew faster than the chicks of the control lots. The shield house gave the best results for this period. The differences in the means for the best house are relatively significant.

Differences at three weeks.--- Again the shield and curtain lots exceed the control lots in rate of growth. The shield chicks averaged 12.44 grams more than the control lots, whereas the curtain chicks weighed 7.21 grams more than the control lots.

The differences secured with the shield house may be considered significant because they are more than three times greater than the standard error.

The difference given by the curtain house may be considered significant. The odds against such a difference occurring as a fluctuation of sampling are about 99 to 1.



Differences at four weeks.-- During the first period the variability was about the same for each house. For the second period, the curtain house showed the largest per cent of variation. The widest ranges during the first and second periods were found in the control lots. As to the rate of growth the shield house ranked first and the curtain was next in order. The shield treatment gave a significant difference over the other two houses whereas the curtain treatment gave a significant difference over the control.

Considering the rate of growth the shield house excelled the control house every time and was excelled by the curtain house only once. See Table 7.

#### FEATHER DEVELOPMENT

The data presented on feathering are shown in Table 8 and 9. Limited attention is given to feathering here. The author plans to present a detailed description of feathering in another section of this paper. The amount of feathering for the third and fourth week is given in per cent by brooding periods.

Feathering at the end of the third week.-- During the first period the control lot was excelled by the

other two houses but the excess amount of feathering was less than 2 per cent for either lot. The second period gave a different picture. During this period the control house gave the largest per cent of feathering. However, the difference between the mean per cent for the control and shield was only 2.80 and the difference between the control and curtain was 3.15 per cent.

Feathering at the end of the fourth week. -- Tables 8 and 9 give the per cent of feathering for the various lots for the two periods, (See page 13). The curtain house gave the smallest per cent for both periods. The shield house gave the greatest amount of feathering during the first period whereas the control ranks first for the second period. Neither treatment gave consistently greater differences.

In a preceding paragraph references were made to what other investigators have had to say about humidity and its influence on the rate of feathering. Table 10 gives the relative humidity for the two periods. For the curtain house readings were taken under the curtain and out in the room.

TABLE 10  
Average Relative Humidity by Brooder Period

Exp. Period	Out Doors	Control	Shield	Curtain	
				Room	Under curtain
Brood I	59.5%	40%	33%	41%	30%
Brood II	61.1%	34%	56.5%	44%	28%

The curtain-room humidity was the greatest for the whole period. The control house gave a higher average humidity reading for the first period than the shield house but the order was reversed for the second period.

The differences in feathering and the differences in the humidity reading are not great enough or consistent enough to warrant very much consideration.

As stated above, it was discovered that the method employed for determining the rate of feathering does not give a complete picture. The method used gave the rate of appearance of feathers and not the rate of growth. Feathers often appear and then grow very slowly. One chick might have feathers in all the feather tracts and still show only a limited amount of contour feathers.



Sanctuary (unpublished data), while trying to discover why the late hatched chicks do not grow as rapidly and feather as well as the early hatch chicks, equipped a colony house with a brooder stove surrounded by the shield and curtain (curtain hanging from the ceiling) used in this experiment, and for a control, used a hot-water-pipe-brooder. The results obtained at the end of five weeks are very interesting. The chicks brooded in the colony house averaged 29.81 per cent more in body weight and 117 per cent more for feathering than the chicks brooded under the hot-water-pipe-brooder.

Sanctuary used per centage of back area covered by feathers as the measure of feathering. After analyzing the room temperature and humidity records for the two houses he was inclined to believe that a low room temperature and high humidity are conducive to rapid body growth and feather development. The author hoped that this study would reveal the exact cause of these differences. Thus far the curtain chicks have not feathered as rapidly as the chicks in the other houses.

Consideration must be given to the fact that during this study the brooder stove in the curtain house was

not equipped with a metal shield and the control was not a hot water pipe brooder but a coal stove brooder. Also it is probable that the room temperature of the pipe-brooder system was appreciably higher than the colony house in this instance.

Apparently the chicks in the curtain house did not make use of the cool exercising area provided for them in the front of the house as much as was expected. Very often they were found, not in the front part of the house, but between the curtain and the north wall which was always very much warmer than the area in front. Observations are still being made on chicks in the three houses, and it is hoped that the data conducted will throw some light on the results obtained by Professor Sanctuary, especially with regard to feathering.

#### TEMPERATURES AND TEMPERATURE GRADIENTS

Poultry men have had much to say about the conditions which should prevail in the brooder house. Only two studies have been encountered that throw any light on conditions as they actually exist during the night.

Data presented in Tables 11 to 16 give a fair representation of the amount of heat that was available for the chicks during the two experimental periods of this study. As before stated, the temperatures were recorded about the time when the chicks nestled down by the stove for the night and in the morning just after they arose from a night of slumber. These records do not give an exact picture of the conditions as they existed during a twenty-four hour period, but they do give a fairly representative average. Thermographs placed at the edge of the hovers showed very well what the chicks had to endure during the night. Unfortunately, the thermograph records are not complete for all the houses and only mention will be made of the temperatures as recorded by them.

The temperature gradients are given for each house by experimental periods (Tables 11 to 16). Considering the two periods as one, the control stove gave the steepest gradients also the highest hover and room temperatures. It will also be recalled that the control house gave the slowest rate of growth. The stove that was equipped with the metal shield produced temperature gradients that exceeded those secured with the curtain house. The room



and hover temperatures of the shield house were also greater than those for the curtain house.

RELATION OF MEAN TEMPERATURE GRADIENT TO  
SIZE OF OPTIMUM BELT

After observing the action of the chicks under various temperatures the author is of the opinion that a temperature of 85 degrees is the minimum and one of 95 degrees is the maximum for the comfort of young chicks.

One might inquire as to how this optimum belt is to be determined and what the effect of the temperature gradient is upon this belt.

Plans IV to VI serve as illustrations of the method used in this study. In order to calculate the assumed optimum belt, the author took 85 degrees where actually found in this study as the beginning point and added the temperature gradient (hover gradient) until the theoretical 95 degrees point was reached. One can readily see that a larger temperature gradient will give a narrow theoretical optimum belt, other factors being equal.

The temperature gradients that were obtained for each stove during the first experimental period were used

in determining the width and area of the optimum belts provided by each stove in the various houses.

The control stove with a gradient of 2.2 degrees gave a belt 5 inches wide with an area of 522 square inches. The temperature gradient for the shield device was 1.5. It gave a belt 6 inches wide with an area equal to 550 inches of available space. Deductions being made for that area occupied by the air-intake-pipe (Plan V). The curtain set up produced better results than either of the other houses. With a gradient of 1.4 degrees change per inch distance it gave an optimum belt 7 inches wide with an area of 640 square inches.

The other factor markedly influencing the area of optimum sleeping conditions, is, of course, the circumference of this belt. Also it should not be overlooked that in cutting off some of the intense radiant heat and reversing the direction of air flow the shield device may provide just as comfortable sleeping conditions at lower mean temperatures than the control stove.

After one studies the temperatures presented in Tables 11 to 16 and plans IV to VI he can see the great need for a system of brooding that will not give such sudden changes



in temperature per inch of linear distances.

Many writers have discussed and recommended what should be the capacity of a brooder. Reference will be made only to those that might be considered the most conservative.

Dougherty (1927) recommended 7 square inches of hover space per chick and says that a hover 42 inches in diameter has a capacity of 200 chicks and a hover 52 inches in diameter has a capacity of three hundred chicks. Moses and Wood (1927) suggested that when using electric brooders at least 7 square inches of floor space per chick should be provided.

Apparently it is not the size of the hover that determines the number of chicks that should be brooded in it but rather the optimum heat belt provided by the brooding device. Accepting 7 square inches of hover space per chick as the standard, none of the optimum areas provided by the various set-ups in this study would accommodate 100 chicks. The curtain house with an optimum belt of 640 square inches would accommodate only 91 chicks.

## MORTALITY

This project was not planned for the purpose of studying liveability of chicks. Nevertheless it is impossible to divorce the mortality problem from the other phases of brooding. Poultry men are not only interested in the rate of growth and feathering resulting from a certain treatment, they also want to know about the mortality record.

Tables 17 and 18 give the mortality records for the two broods in number and per cent by weekly intervals. Rigid culling was not practiced nor was any effort made to distinguish between the number of chicks that died and those that met death accidentally.

The mortality record for Brood I. Table 17 shows that the per cent mortality for the curtain house was 6.1, the control 9.5 per cent and 18.9 per cent for the shield house. Considering the mortality record for the curtain house, it can be seen that all the chicks except one died during the first week. The chicks that died in the control house died during the first and second weeks. The situation is some what similar for the shield lot.

However, the mortality here is distributed throughout the brooding period.

The per cent mortality for the shield lot of chicks appear to be very great. The reason for this high mortality record is pretty well known to the author. On March the 9th the stove pipe became disconnected during the night and the temperature at the hover's edge fell to 30 degrees. Only five chicks were found dead. The next morning, however, the mortality record was increased during the day. Within a few days after that the temperature again dropped to 30 degrees at the hover's edge, the chicks showed symptoms of having been chilled and the mortality record increased as the days passed. The reader probably recalls the fact that the shield lot of chicks gave the largest mean weight for Brood I. It is possible that only the most vigorous chicks survived the adverse environmental condition that they underwent. However, it is to be noted that in the second brood with a mortality practically the same as in the control lot, the shield house again produced the heavier chicks. Guinness (1932) reported that the weather for March, at Amherst, was somewhat cooler than normal. The mean



temperature for the month was 51.9 degrees while the normal temperature for March is 54.2 degrees. The lowest temperature was 9 degrees on the 9th, the night the stove pipe became disconnected. During the first two weeks the chicks were in the houses the maximum velocity of wind ranged from 13 to 48 miles per hour, the mean hour velocity for the month of March was 10 miles per hour. It was almost impossible to maintain comfortable conditions in the house during this period. This was especially true for the control and shield houses. The temperatures in the curtain house did not fluctuate as widely as those in the other houses. Temperature records at the hover's edge showed greater extremes in that of the control device than in the other two. Data presented do not show this. The thermograph records revealed the variations in temperatures at the hover's edge for the various set-ups.

Mortality Record for Brood II. -- The mortality record for this period might be regarded as being favorable. Taking into consideration the fact that culling was not practiced. During this period all of the deaths occurred during the first and second weeks. The per cent

mortality for the various houses is given in Table 18. The control house gave the best record for this period. Its mortality record is only 7 per cent. The shield lot ranks second with a death rate amounting to 7.8 per cent. The curtain treatment gave the highest mortality record, 8.7 per cent of the curtain chicks dying during this period.

The curtain lot of chicks were either over-heated or chilled during this period. Unfortunately the thermograph did not give accurate reading for the first week of this brooder period. It was working but it was later discovered that the recording needle was pressing against the casing and was not recording accurately.

#### SLEEPING HABITS OF CHICKS

Catalogues put out by poultry supply houses often contain pictures showing chicks in a perfect circle around a hover. In determining the capacity of a brooder, calculations are usually made on the basis of the complete circumference of the hover. Poultrymen have frequently fallen into error by following recommendations as to the capacity of brooders. As to how often chicks form

a complete circle around the hover and why they do not always form this circle the author will try to answer.

Plans 7 to 9 show the most common arrangements of the chicks during the two experimental periods. The chicks in the control house persistently slept in an arc at the northwest corner of the stove. During the early part of the brooding period (first two weeks) they remained under the hover. As they grew older they continued to get farther and farther away from the stove.

During the 3rd and 4th weeks of the second experimental period about one third of the chicks left the hover altogether and slept in the north west corner of the house. The reason for this peculiar action of the control chicks can not easily be explained, however, the following factors seem to account for their habit of bunching together within such narrow bounds.

The windows in the front of this house (control) as well as the other houses, are equipped with muslin cloth, cold air finds its way through this cloth and around the frame and is augmented by that coming through the cracks of the door. This air sets up a floor draft that makes conditions unfavorable for the chicks in all the areas



around the hover with the exception of that space which is protected by the stove. In this case the stove breaks the floor draft and warms the air before it reaches the chicks.

Figure 8 shows the predominant arrangement of the chicks around the hover, in the shield house. The chicks in this house used a greater amount of the area that encircled the stove.

Crowding was less prevalent in this house than in the control. The reader no doubt remembers that this house gave a more rapid rate of growth than the chicks brooded in the control.

The shield device tends to produce outgoing currents of air at the hover's edge and therefore may be considered to counteract the floor drafts going under the hover. (Fig. 8) The writer is inclined to believe that this modification of floor drafts caused by the shield device had some influence on the way the chicks settled down around the stove in this house. The figure shows that the arc occupied by the chicks in this house extended farther to the south on both sides of this stove than did the area occupied by the chicks in the control. In fact the chicks in the control were never found on the

east side of the stove unless the velocity of the wind was negligible.

Visits to the curtain house never found the chicks bunching together within a limited area. However, they kept away from the front of the stove on windy nights.

Figure 9 gives the most common arrangement of the chicks under the curtain set up. The chicks in this house appeared to be very comfortable most of the time. A temperature of 70 degrees at the hover's edge seemed to give heat enough for the comfort of the chicks in this lot. The illustration given in figure 9 shows that the chicks usually spent the night in the area between the curtain and the hover's edge.

The chicks brooded in this house gave a fair rate of growth, some what better than those in the control, but did not equal the rate of growth secured with the shield set-up. Possibly the curtain chicks enjoyed the conditions provided by the curtain so well that they neglected the mash that was in the hoppers which were placed in the cold area outside of the curtain where it was hoped that they would spend much of their time.

The chicks learn at a very early age to locate in



those parts of the colony house which at "bed-time" they have found to be most comfortable. But let the source of ventilation be changed very markedly and it will be found that the chicks are capable of choosing the part of the house and the section of the hover which are most comfortable.

Several times during the experiment the writer tested the ability of the chicks to determine what part of the house or area around the hover provided the most desirable place in which to locate. This was done by ventilating the houses by different openings. These adjustments were possible on all sides but the north. Most of the chicks usually slept on the north west side of the stove when the ventilation was from the south window. When the west window was left open, instead of the south, until after time for them to settle down for the night, they did not go to bed in the usual place but sought the south east side of the stove, a place rarely used.

In the curtain house the chicks seldom nestled down in front of the stove even though the curtain (Fig. 3-b.) extended to the floor on the south side. Frequently

when the writer arrived to take the afternoon readings the chicks were found in front of the stove even though the window was open on that side. Undoubtedly the curtain prevented a floor draft at this point and the area in front of the stove was the coldest place with the window up and the warmest place when the window was down.

When a means of overcoming floor drafts is perfected in colony house brooding, sleeping conditions will have been improved.

Mention was made of the fact that the chicks seldom made use of the south side of the hover, the side facing the muslin covered windows, because of the prevalent floor drafts on that side. During the last two weeks of the second experimental period, on nights when the velocity of the wind was nearly negligible, the chicks formed a complete circle around the hover. This shows that wind velocity has a marked influence upon sleeping areas.

### SUMMARY

1. Data presented show that the chicks which were brooded under the stove equipped with the metal shield gave the largest mean weight at the end of each experimental period: the curtain lot ranked second each time.
2. The curtain house had the lowest room temperature but the differences between the different houses were almost negligible. The mean room temperature for each house was below 70 degrees.
3. Differences in humidity were negligible.
4. Differences in rates of feathering for the three set-ups were negligible. Differences in room temperature and humidity maintained in the three houses were insignificant. It is doubtful if differences in hover conditions alone would produce differences in the rate of feather growth.
5. The control house showed the largest temperature gradient: the shield was next in order and the curtain set-up showed the smallest gradient.

6. The calculated optimum sleeping belt for each house was very narrow. The curtain set-up gave the widest belt and the shield ranked second.
7. The chicks that were brooded in the curtain and shield houses used more of the area around the stove than the chicks brooded in the control house, probably because the curtain prevented floor drafts and because the shield device produced comfortable conditions over a larger area.
8. The mortality was not excessive. It was variable, but not consistently so with reference to the different houses.
9. Observations indicated that the chicks were capable of choosing the most comfortable places for sleeping when changes in method of ventilation rendered habitually used sleeping places uncomfortable.





- Hays, F. A.            The Significance of Differences in Means in Repetition Experiments. Poultry Science, Vol. XI, No. 1, pp. 14-17.        1932
- Jull, M. A. and J. P. Quinn. The Relationship Between the Weight of Eggs and the Weight of Chicks According to Sex. Journal Agriculture Research 31: 223-226.        1925
- Jull, M. A. and Titus. Growth of Chicks in Relation to Feed Consumption. Journal Agriculture Research Bulletin 36: 521-550        1928
- Jull, M. A.            Poultry Husbandry, pp. 1-639. McGraw-Hill Company, New York.        1930
- Kaupp, B. F.            The Rate of Growth of Single Comb Rhode Island Reds. 1921 Poultry Science 1: 39-43.
- Kelly, M. A. R.        Ventilation of Farm Barns. United States Dept. of Agri. Tech. Bulletin 87, pp. 1-72        1930.
- Messier, W. Edward Battery Brooding. New England Poultry Man. February 15, 1931
- Moses, B. D. and T. A. Wood. The Electric Brooder. California, Agriculture Experiment Station Bulletin 441, pp. 3-39.        1927
- Sanctuary, W. C.        Where Will the Chicks Sleep? American Poultry Journal, Vol. 61, No. 5 pp. 7        1930
- Sanctuary, W. C.        What do the Chicks do with their Time. American Poultry Journal, Vol. 60, No.3, pp. 28.        1929
- Smyth, J. R.            Artificial Brooding of Chicks. Kentucky Agriculture College Extension Division Cir. 157, pp. 3-13.
- Thompson, W. C. and Forest H. T. Clickner. Care and Management of Brooder Chicks. New Jersey Experiment Sta. Cir. 199, pp. 1-32.
- Upp, C. W.            The Rate of Growth of Single Comb Rhode Island Reds. Poultry Sci. 1: 39-43. 1921

Brood I.

Table 1. Control. Weight in Grams

79 Individuals

	Chick Wt.	Wt. at 1 Week	Wt. at 2 Weeks	Wt. at 3 Weeks	Wt. at 4 Weeks
Range	34 - 47	40 - 72	72 - 134	114 - 179	142 - 326
Mean	39.9±.32	56.1±.44	95.8±1.61	150.±1.64	214.3±2.31
Standard deviation	4.3±.23	5.7±.31	21.3±1.30	21.6±1.16	30.4±1.16
Coefficient of variability	10.8	10.3	22.2	14.6	14.2

Table 2. Shield. Weight in Grams

68 Individuals

	Chick Wt.	Wt. at 1 Week	Wt. at 2 Weeks	Wt. at 3 Weeks	Wt. at 4 Weeks
Range	34 - 45	39 - 73	70 - 132	100 - 214	142 - 312
Mean	39.8±.18	56.7±.71	101.2±1.10	160.9±.69	232.1±2.47
Standard deviation	2.2±.13	1.8±.10	13.5±.78	8.4±.49	30.2±1.75
Coefficient of variability	5.6	3.2	13.3	4.9	13.0

Table 3. Curtain. Weight in Grams

79 Individuals

	Chick Wt.	Wt. at 1 Week	Wt. at 2 Weeks	Wt. at 3 Weeks	Wt. at 4 Weeks
Range	34 - 47	46 - 73	68 - 132	92 - 207	113 - 298
Mean	39.3±.26	58.9±.41	101.8±1.02	158±2.30	227.6±2.39
Standard deviation	3.4±.18	5.3±.29	13.4±.72	30.2±1.88	31.5±1.69
Coefficient of variability	8.7	9.1	13.1	19.1	13.9



Brood II.

Table 4. Control. Weight in Grams

61 Individuals

	Chick Wt.	Wt. at 1 Week	Wt. at 2 Weeks	Wt. at 3 Weeks	Wt. at 4 Weeks
Range	34 - 48	43 - 72	62 - 134	72 - 220	99 - 326
Mean	39.9 $\pm$ .54	51 $\pm$ .66	84.7 $\pm$ 1.1	131.8 $\pm$ 1.41	188.6 $\pm$ 1.62
Standard deviation	6.3 $\pm$ .38	7.7 $\pm$ .47	12.5 $\pm$ .76	16.3 $\pm$ .99	18.8 $\pm$ 1.15
Coefficient of variability	15.8	15.1	14.7	12.4	9.9

Table 5. Shield. Weight in Grams

60 Individuals

	Chick Wt.	Wt. at 1 Week	Wt. at 2 Weeks	Wt. at 3 Weeks	Wt. at 4 Weeks
Range	34 - 45	42 - 70	54 - 132	83 - 194	113 - 312
Mean	39.8 $\pm$ .16	56 $\pm$ .36	89.4 $\pm$ 1.28	145.7 $\pm$ 1.71	207.5 $\pm$ 1.23
Standard deviation	1.81 $\pm$ .11	4.2 $\pm$ .25	14.7 $\pm$ .91	19.6 $\pm$ 1.21	14.2 $\pm$ .87
Coefficient of variability	4.5	7.5	16.4	13.1	6.8

Table 6. Curtain. Weight in Grams

61 Individuals

	Chick Wt.	Wt. at 1 Week	Wt. at 2 Weeks	Wt. at 3 Weeks	Wt. at 4 Weeks
Range	31 - 48	42 - 70	54 - 106	80 - 180	113 - 269
Mean	39.4 $\pm$ .19	52.2 $\pm$ .55	81.9 $\pm$ .88	134.2 $\pm$ .48	194.6 $\pm$ 2.53
Standard deviation	2.2 $\pm$ .14	6.45 $\pm$ .39	10.2 $\pm$ .62	9.77 $\pm$ .60	29.3 $\pm$ 1.79
Coefficient of variability	5.6	12.3	12.5	7.3	15.1



Table 7. Result of Treatments

1 Week

Treatment	Mean Wt. 1 week	Diff.	<u>Difference</u> Stand. Error	P.
Control	53.3	3.1	1.37	.1711
Shield	56.4	0.8	0.79	.6297
Curtain	55.6	2.3	1.01	.3127
Control	53.3			

St. Error of Mean Difference = 2.27

Result of Treatment 2 week

Treatment	Mean Wt. 2 weeks	Diff.	<u>Difference</u> Stand. Error	P.
Control	90.3	4.9	1.94	.0466
Shield	95.2	3.3	1.31	.0992
Curtain	91.9	1.6	0.63	.5285
Control	90.3			

St. Error of Mean Difference = 2.52

Result of Treatment 3 Week

Treatment	Mean Wt. 3 weeks	Diff.	<u>Difference</u> Stand. Error	P.
Control	140.90	12.44	5.87	0
Shield	153.34	7.21	3.40	.0008
Curtain	146.13	5.23	2.47	.0136
Control	140.90			

St. Error of Mean Difference = 2.12

Result of Treatment 4 Week

Treatment	Mean Wt. 4 weeks	Diff.	<u>Difference</u> Stand. Error	P.
Control	201.43	18.38	8.17	.0
Shield	219.81	8.65	3.84	.0001
Curtain	211.16	9.73	4.32	.0
Control	201.43			

St. Error of Mean Difference = 2.25

TABLE 8.

BROOD I. Feathering in per cent at the end of the third and fourth week.

	No. Chick	3 weeks	4 weeks
Control	79	53.80%	86.73%
Shield	68	55.15%	87.87%
Curtain	79	55.54%	83.87%

TABLE 9.

BROOD II. Feathering in per cent at the end of the third and fourth week.

	No. Chick	3 weeks	4 weeks
Control	61	59.43%	83.60%
Shield	60	56.63%	83.23%
Curtain	61	53.28%	75.82%

Brood I.

Table 11. Control House  
Temperatures and Temperature Gradients Exp. I.

Week	Side	Inches from Stove										*Hover's		
		33	30	27	24	21	18	15	12	9	6	3	Edg.	Room
1.	S.	63	64	65	68	72	77	83	90	96	107	113	95	56
	N.	63	64	65	68	73	76	81	87	93	104	109	106	59
2.	S.	54	59	58	61	65	70	76	81	87	93	97	91	49
	N.	54	57	58	62	67	72	80	86	94	104	108	108	50
3.	S.	59	59	61	62	69	75	80	86	94	101	105	81	57
	N.	61	61	63	64	71	75	82	87	94	100	105	88	58
4.	S.	64	65	66	68	74	78	85	91	96	104	108	78	56
	N.	63	64	65	68	74	79	88	99	103	114	122	96	61
Aver-	S.	60	61	62.5	64.7	70	75	81	87	88.2	96.2	105.7	86.2	54.2
	N.	60.2	61.5	62.7	65.5	71.2	76.2	82.7	88.7	96	105.5	111	99.5	57
Grand	S.													
	Average N.	60.1	60.6	61.6	65.1	70.6	75.6	81.8	87.8	92.1	100.8	108.3	92.8	55.6

Gradient for whole distance = 1.6

Gradient from hover's edge (H) = 2.2

\*These readings obtained by thermometers hung behind hover curtains.

Breed I.

Table 12. Shield House

Temperatures and Temperature Gradients

Exp. I.

Week	Side	Inches from Stove											*Hover's	
		25	30	27	24	21	18	15	12	9	6	3	Edge	Room
1.	S.	61	62	62	64	64	64	74	78	84	89	92	83	60
	N.	64	63	66	66	67	72	75	81	89	91	95	87	60
2.	S.	54	55	56	58	62	65	75	77	83	87	88	89	54
	N.	57	58	59	63	66	70	78	84	88	94	96	98	57
3.	S.	60	61	62	60	64	68	75	83	88	90	93	89	61
	N.	63	63	65	65	68	72	79	85	91	94	96	86	62
4.	S.	64	66	67	68	71	73	80	83	89	95	96	87	63
	N.	62	63	64	65	67	69	77	82	87	93	94	92	62
Average	S.	59.7	61	61.7	62.5	65.2	67.5	76	80.2	86	90.2	92.2	87	59.5
	N.	61.5	61.7	63.5	64.7	67	70.7	77.2	83	88.7	93	95.2	88.2	60.2
Grand Average	S. + N.	60.6	61.7	62.6	63.6	66.1	69.1	76.6	80.6	87.5	91.6	93.7	87.6	59.8

Gradient for whole distance = 1.1

Gradient from hover's edge = 1.5

\*These readings obtained by thermometers hung behind hover curtains.



Brood I.

Table 13. Curtain House  
Temperatures and Temperature Gradients

Exp. I.

Week	Side	Inches from Stove										Hover's		
		21	24	27	30	33	36	39	42	45	48	Edge	Room	
1.	S.	72	67	64	63	60	74	79	87	88	92	97	82	50
	N.	72	68	66	64	62	74	78	83	89	95	99	80	52
2.	S.	71	67	62	58	56	75	79	85	88	90	92	64	43
	N.	67	64	55	54	52	69	75	77	84	89	83	65	48
3.	S.	74	70	67	65	63	78	84	87	90	91	95	76	53
	N.	74	69	67	65	64	78	83	88	93	98	101	73	56
4.	S.	77	72	70	68	67	90	85	88	91	98	100	78	56
	N.	77	71	70	69	68	80	87	92	99	108	110	80	57
Average	S.	73.5	69	65.7	63.5	61.5	76.7	81.2	86.2	89.2	92.7	95.5	75	50.5
	N.	72.5	68	64.5	63	61.5	75.2	80.7	85	91.2	97.5	99.5	74.5	53.2
Grand Average	S.	73	68.5	65.1	63.2	61.5	75.9	80.9	85.6	90	95	97.5	74.7	51.8

\*These readings obtained by thermometers hung behind hover curtains.

Gradient for whole distance = 1.2

Gradient from hover's edge (H) = 1.4

Brood II.

Table 14. Control House  
 Temperatures and Temperature Gradients Exp. II.

Week	Side	Inches from Stove										*Hover's		
		33	30	27	24	21	18	15	12	9	6	3	Edge	Room
1.	S.	66	67	67	69	73	75	80	86	90	94	99	86	62
	N.	67	68	69	71	76	77	83	88	93	96	101	92	63
2.	S.	66	66	67	68	73	76	84	86	90	95	100	82	62
	N.	66	67	68	73	76	79	87	92	98	104	111	97	62
3.	S.	72	73	73	76	77	81	86	91	96	99	103	83	68
	N.	72	73	73	77	79	82	87	92	97	101	105	86	69
4.	S.	71	72	72	74	76	77	83	87	91	94	98	73	62
	N.	71	72	72	74	76	78	85	89	95	99	104	101	63
Average	S.	68.7	69.5	69.7	71.7	74.7	77.2	83.2	87.5	91.7	95.5	100	81	63.5
	N.	69	70	70.5	73.7	76.7	79	85.5	90.2	95.7	100	105.2	94	64.2
Grand	S.													
Average	N.	68.8	69.7	70	72.7	75.7	78.5	84.3	88.8	93.7	97.7	102.6	87.5	63.8

Gradient for whole distance = 1.1  
 Gradient from hover's edge (H) = 1.6

\*These readings obtained by thermometers hung behind hover curtains.

Brood II.

Table 15. Shield House  
Temperatures and Temperature Gradients Exp. II.

Week	Side	Inches from Stove										Hover's		
		21	24	27	30	35	21	24	27	30	35	%	Edge	Room
1.	S.	70	68	66	66	65	70	76	81	85	87	89	85	65
	N.	74	70	69	68	68	76	80	83	87	89	92	89	65
2.	S.	69	67	65	64	64	71	78	82	84	88	90	84	64
	N.	73	70	67	67	67	75	81	85	89	92	92	89	63
3.	S.	73	72	69	69	69	74	80	85	90	92	96	91	69
	N.	76	74	71	71	71	78	83	86	93	94	96	91	70
4.	S.	72	71	69	68	68	73	78	85	86	86	89	89	69
	N.	73	72	70	70	69	74	81	85	87	89	90	87	67
Aver-	S.	71	69.5	67.2	66.5	66.5	72	78	82	86	88.2	91	87.2	66.7
age	N.	74	71.5	69.2	68.7	68.7	75.2	79.7	84.7	91	92.2	89.0	89.0	66.2
Grand	S.													
Average	N.													
		68	70.5	68	67.6	67.6	73.6	78.8	83.3	87.5	89.6	91.6	89.6	66.4

Gradient for whole distance = 0.8  
Gradient from hover's edge (H) = 1.2

\*These readings obtained by thermometers hung behind hover curtains.



Brood II.

Table 15. Shield House

Temperatures and Temperature Gradients

Exp. II.

Week	Side	Inches from Stove										Hover's	
		21	24	27	30	33	36	39	42	45	48	2. Edge	Room
1.	S.	65	66	66	70	70	76	81	85	87	89	85	65
	N.	68	69	70	74	76	80	83	87	89	92	89	65
2.	S.	64	64	65	69	71	78	82	84	88	90	84	64
	N.	67	67	67	73	75	81	85	89	92	92	89	63
3.	S.	69	69	69	73	74	80	85	90	92	96	91	69
	N.	71	71	71	76	78	83	88	93	94	96	91	70
4.	S.	68	68	69	72	75	78	80	85	86	89	89	69
	N.	69	70	70	73	74	81	85	87	89	90	87	67
Aver-	S.	66.5	67	67.2	69.5	71	72	78	82	86	88.2	91	87.2
age	N.	68.7	69	69.2	71.5	74	75.2	79.7	84.7	89	91	92.2	89.0
Grand	S.												
Average	N.	67.6	68	68	70.5	72.5	73.6	78.8	83.3	87.5	89.6	91.6	89.6

Gradient for whole distance = 0.8

Gradient from hover's edge (H) = 1.2

\*These readings obtained by thermometers hung behind hover curtains.



Brood II.

Table 16. Curtain House  
Temperature and Temperature Gradients Exp. II.

Week	Side	Inches from Stove											*Hover's	
		24	27	30	33	36	39	42	45	48	51	54	Edge	Room
1.	S.	71	72	74	78	79	83	87	91	93	97	76	61	
	N.	72	73	75	80	83	88	91	95	98	99	83	63	
2.	S.	70	72	76	81	83	89	92	98	101	104	75	58	
	N.	71	73	76	81	85	91	96	103	109	114	84	62	
3.	S.	69	70	72	75	77	80	82	87	90	91	78	62	
	N.	72	72	75	78	81	86	91	97	101	105	80	63	
4.	S.	70	71	72	74	75	79	81	86	86	89	78	61	
	N.	72	73	74	77	79	83	86	90	93	95	75	64	
Aver-	S.	68.7	70	71.2	73.5	77.7	78.5	82.7	85.5	90.5	92.5	95.3	82	60.5
age	N.	70	71.7	72.7	74.2	79	82	87	91	96.2	100.2	105.2	80.5	63
Grand	S.	69	70.8	71.9	73.8	78.3	80.2	84.8	88.2	93.3	96.8	99.3	81.2	61.7
Average	N.	70	71.7	72.7	74.2	79	82	87	91	96.2	100.2	105.2	80.5	63

Gradient for whole distance = 1

Gradient from hover's edge (H) = 1.3

\*These readings obtained by thermometers hung behind hover curtains.

TABLE 17.

## BROOD I. Mortality

House	No. Chick	Mortality 1 week		Mortality 2 week		Mortality 3 week		Mortality 4 week		TOTAL	
		No.	%	No.	%	No.	%	No.	%		
Curtain	116	6	5.2	0	0	1	.9	0	0	7	6.1
Control	116	8	6.9	3	2.6	0	0	0	0	11	9.5
Shield	116	15	12.8	4	3.5	2	1.7	1	.9	22	18.9

TABLE 18.

## BROOD II. Mortality

House	No. Chick	Mortality 1 week		Mortality 2 week		Mortality 3 week		Mortality 4 week		Total	
		No.	%	No.	%	No.	%	No.	%		
Control	114	5	4.4	3	2.6	0	0	0	0	8	7
Shield	114	6	5.2	3	2.6	0	0	0	0	9	7.8
Curtain	114	4	3.5	6	5.2	0	0	0	0	10	8.7

PLAN I

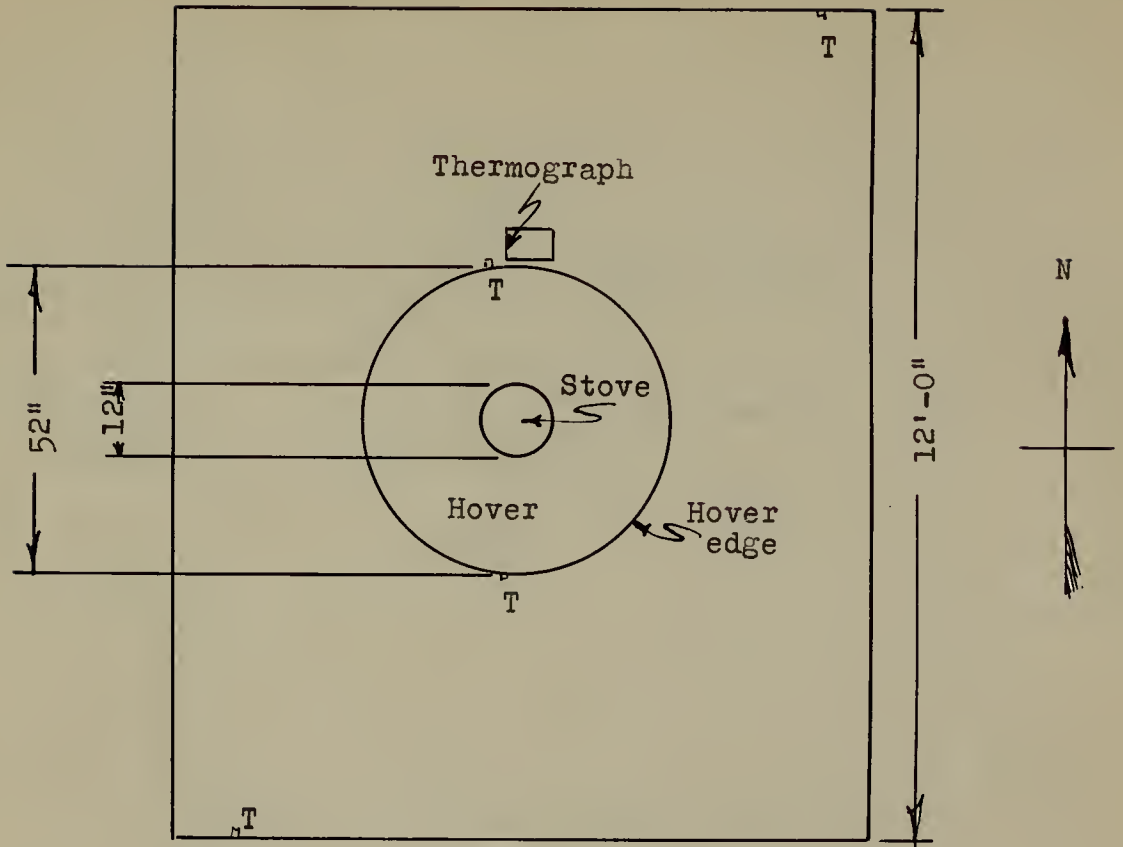

Fig. 1,a. Floor Plan

Scale:-  $3/8" = 1'-0"$

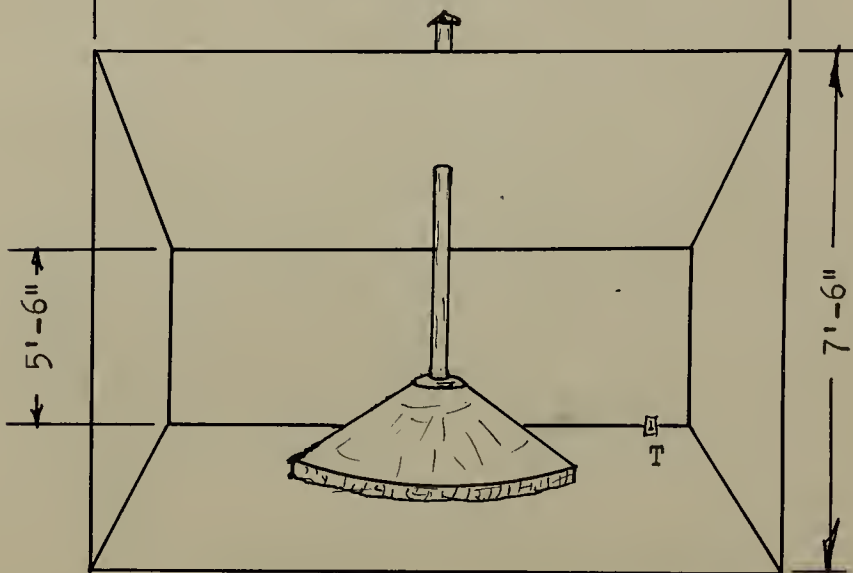

Fig. 1,b. Front Elevation

PLAN II

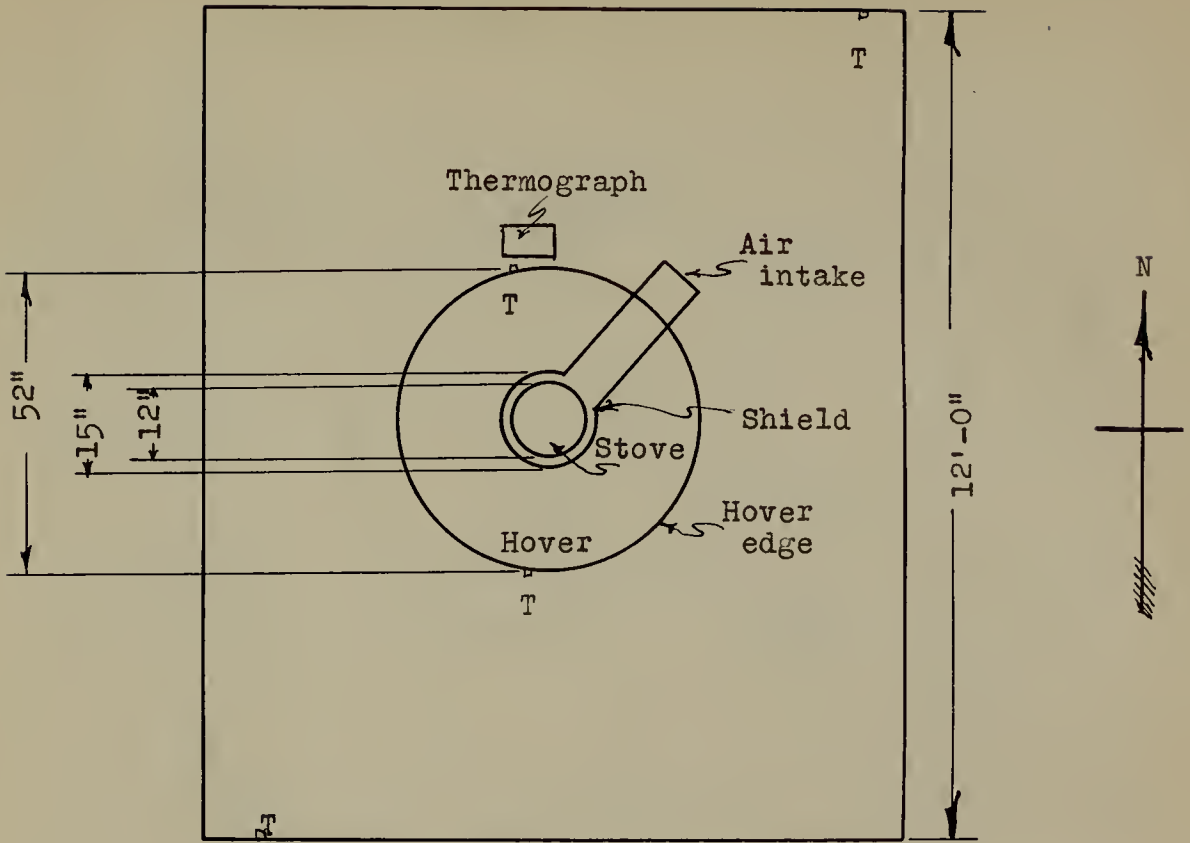

Fig. 2, a. Floor Plan

Scale:-  $3/8" = 1'-0"$

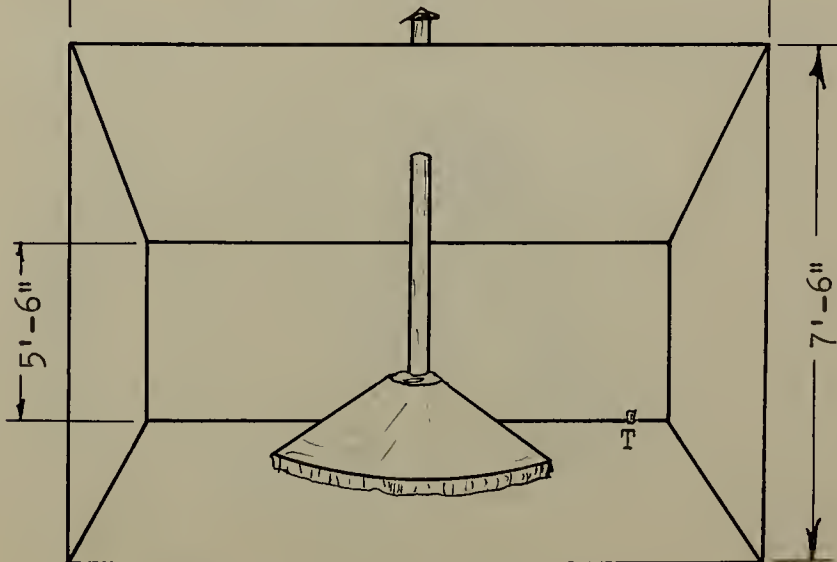

Fig. 2, b. Front Elevation



PLAN III

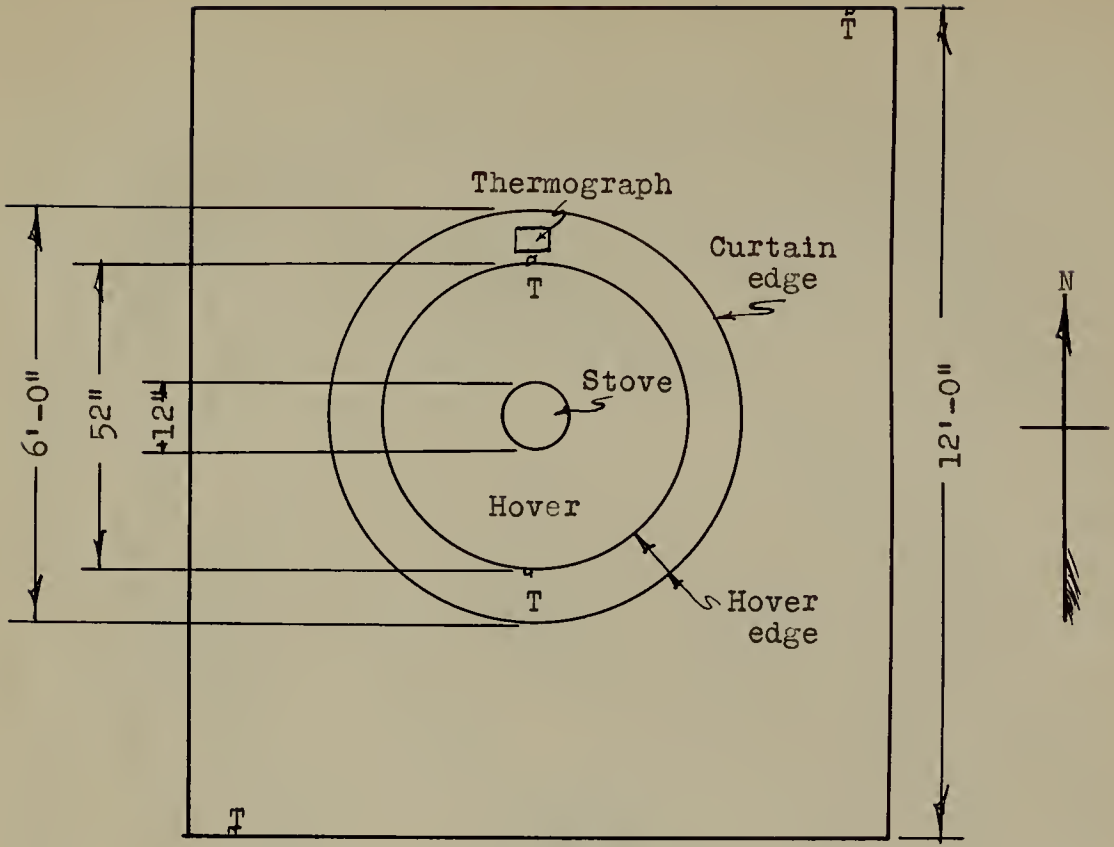

Fig. 3a. Floor Plan

Scale:-  $\frac{3}{8}'' = 1'-0''$

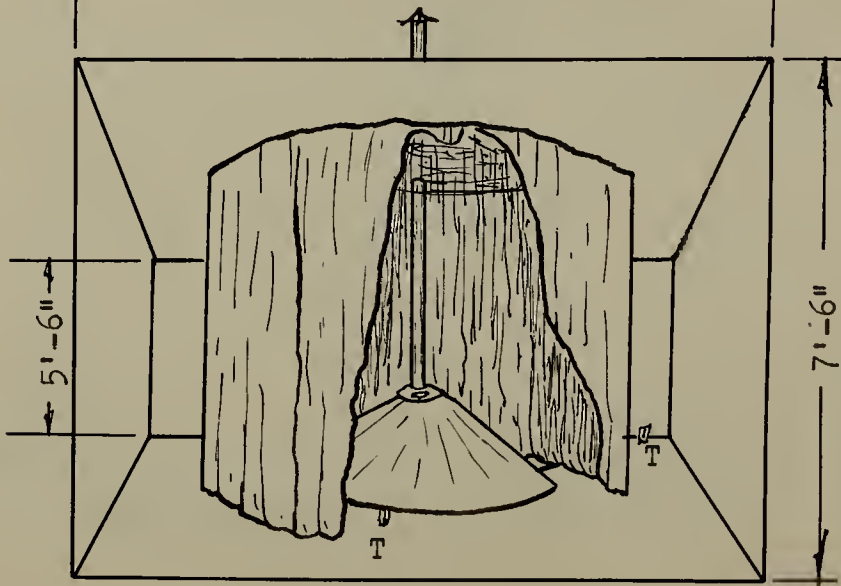
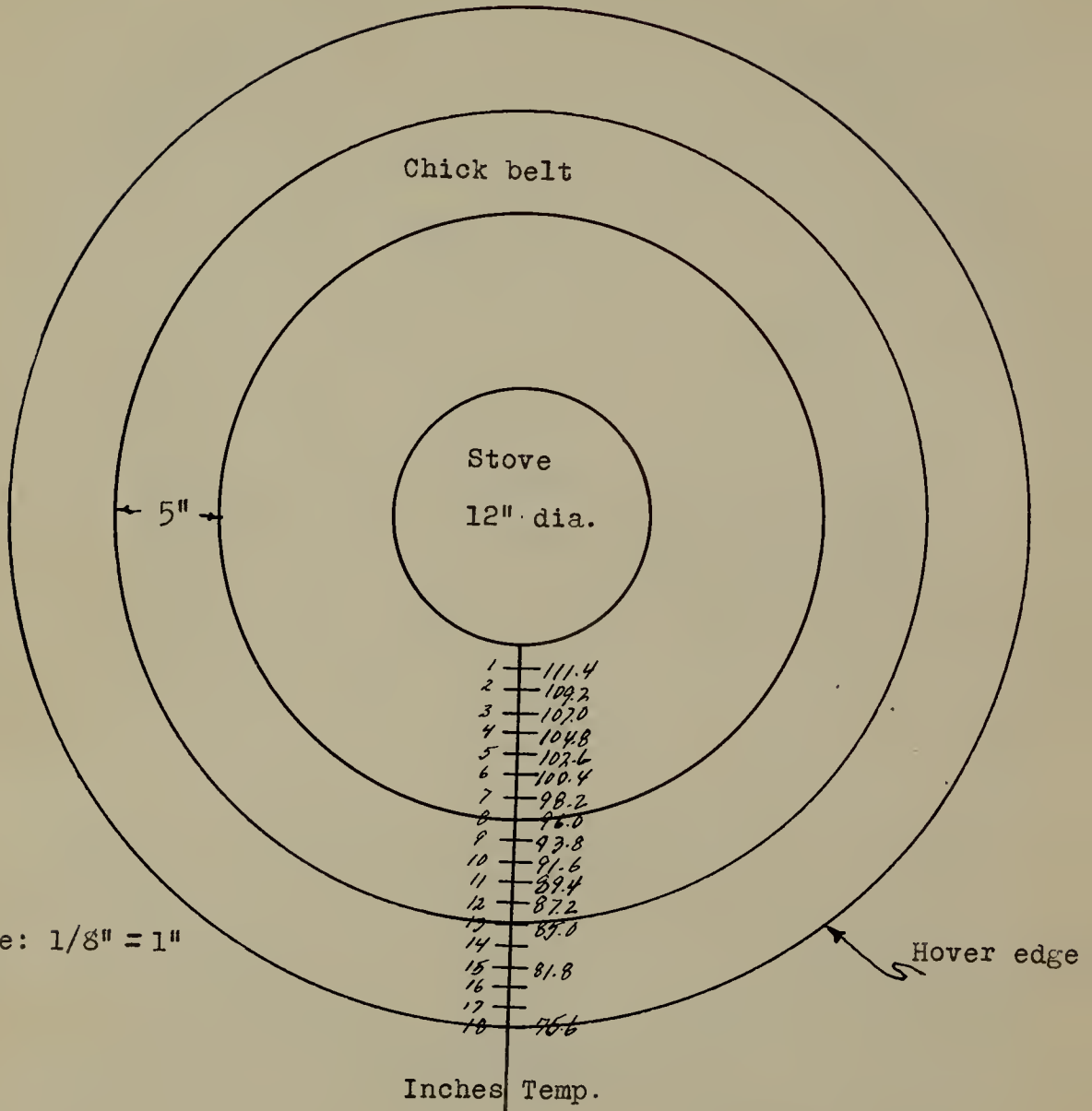

Fig. 3b. Front Elevation

PLAN IV



CONTROL

Gradient equals 2.2 degrees change per inch of distance

Area of chick belt equals ap. 522.00 sq. in.

PLAN V

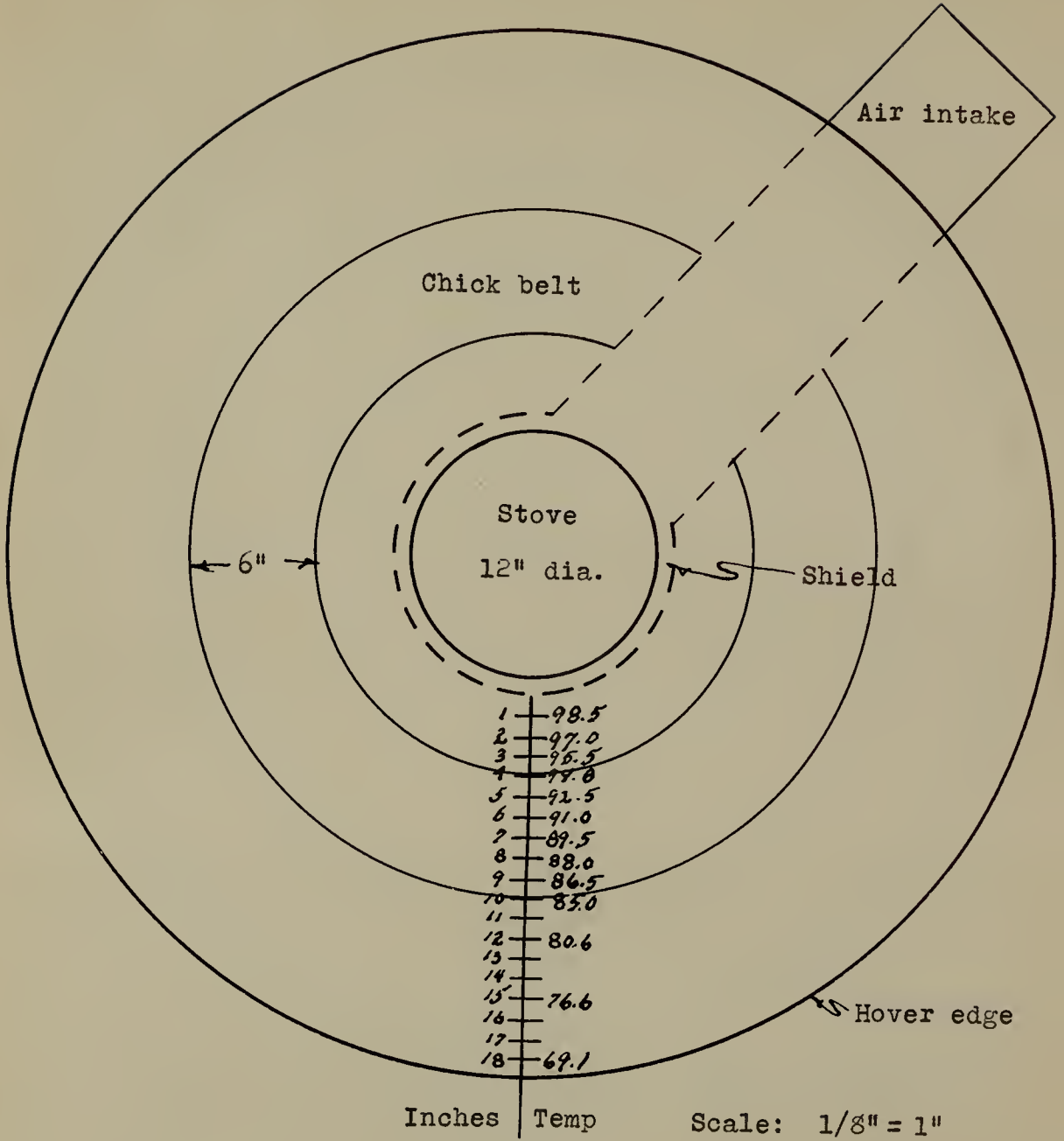

SHIELD

Gradient equals 1.5 degrees change per inch of distance.  
 Area of chick belt equals ap. 550 sq. in.



PLAN VI

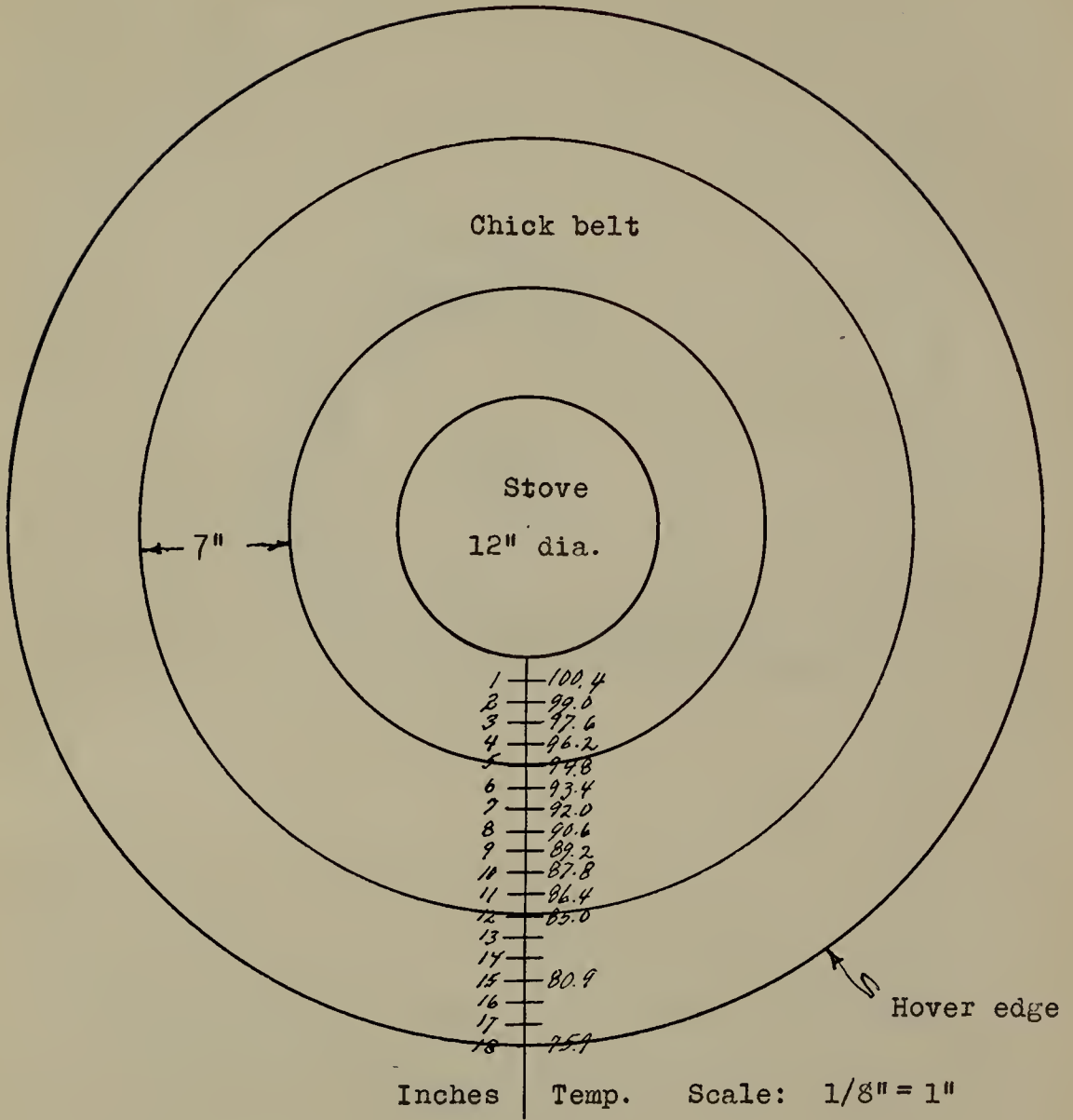

CURTAIN

Gradient equals 1.4 degrees change per inch of distance.

Area of chick belt equals ap. 640 sq. in.

PLAN VII

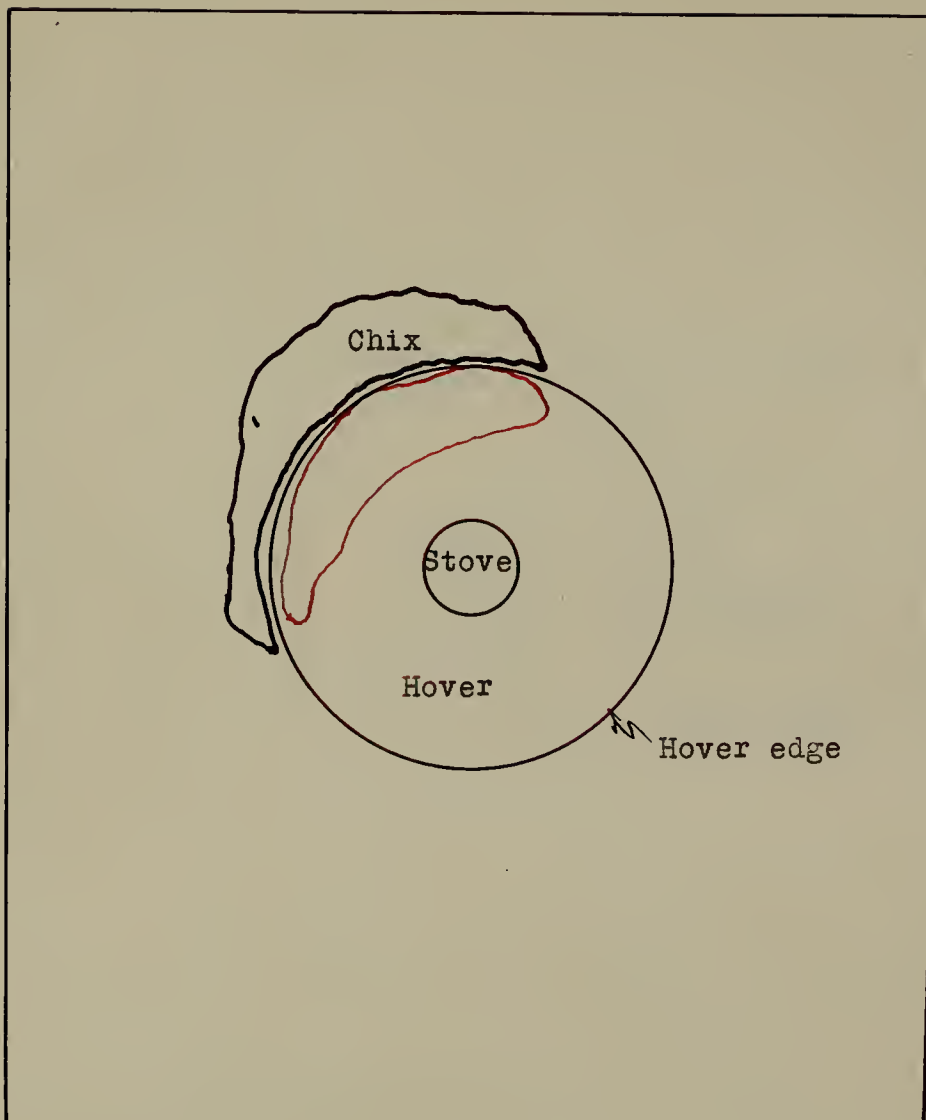

CONTROL

- Young chix.
- Older chix.

Scale: 1/2" = 1'-0"

PLAN VIII

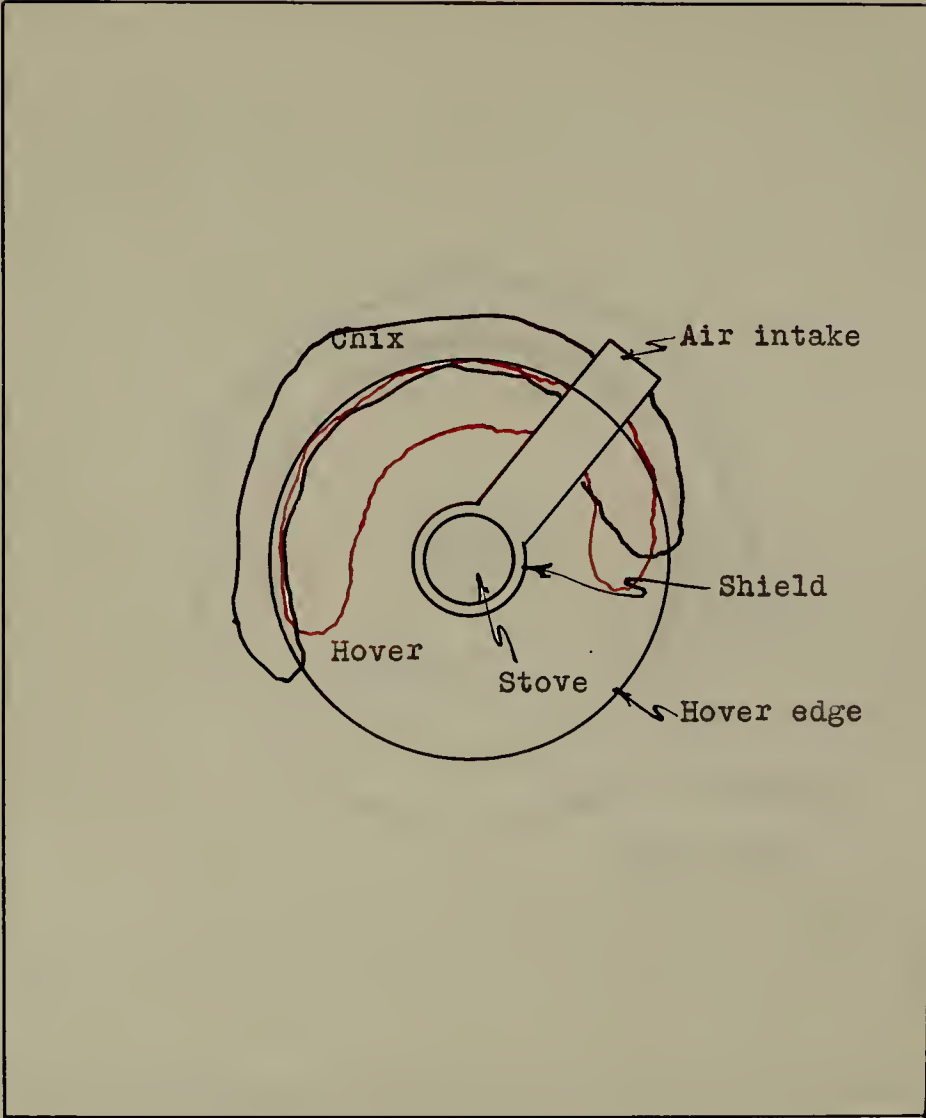

SHIELD

- Young chix.
- Older chix.

Scale:  $1/2" = 1'-0"$



PLAN IX

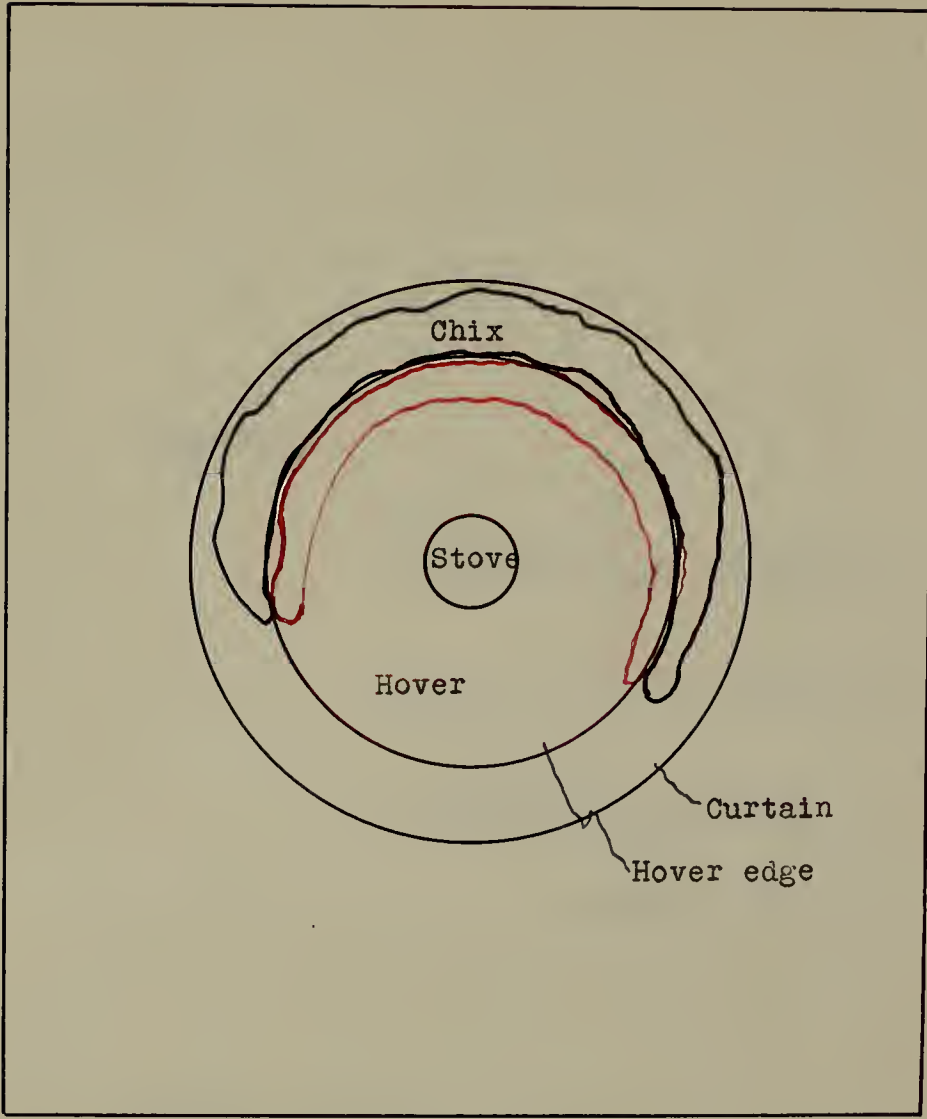

SHIELD

- Young chix
- Older chix

Scale: 1/2" = 1'-0"

Approved by:

W. O. Sweeney

W. O. Sweeney

A. B. Beaumont

Graduate Committee

Date \_\_\_\_\_

