

Fall November 2014

Contrastive Topic: Meanings and Realizations

Noah Constant
University of Massachusetts, Amherst

Follow this and additional works at: https://scholarworks.umass.edu/dissertations_2



Part of the [Linguistics Commons](#)

Recommended Citation

Constant, Noah, "Contrastive Topic: Meanings and Realizations" (2014). *Doctoral Dissertations*. 171.
<https://doi.org/10.7275/wdwx-7p85> https://scholarworks.umass.edu/dissertations_2/171

This Open Access Dissertation is brought to you for free and open access by the Dissertations and Theses at ScholarWorks@UMass Amherst. It has been accepted for inclusion in Doctoral Dissertations by an authorized administrator of ScholarWorks@UMass Amherst. For more information, please contact scholarworks@library.umass.edu.

**CONTRASTIVE TOPIC:
MEANINGS AND REALIZATIONS**

A Dissertation Presented

by

NOAH CONSTANT

Submitted to the Graduate School of the
University of Massachusetts Amherst in partial fulfillment
of the requirements for the degree of

DOCTOR OF PHILOSOPHY

September 2014

Department of Linguistics

© Copyright by Noah Constant 2014

All Rights Reserved

**CONTRASTIVE TOPIC:
MEANINGS AND REALIZATIONS**

A Dissertation Presented

by

NOAH CONSTANT

Approved as to style and content by:

Angelika Kratzer, Chair

Elisabeth Selkirk, Member

Seth Cable, Member

Adrian Staub, Member

John Kingston, Department Head
Department of Linguistics

ACKNOWLEDGMENTS

The ideas in these pages—all the good ones at least—are the fruit of conversations. The most numerous and the most enjoyable of these were conversations with my committee members, so first and foremost, I'd like to thank them. It's hard to convey the extent to which my committee provided all the essential seeds, from which the work grew. Thinking back, I'm still astonished and humbled by their dedication of time and critical thought. In a better world, the thesis would have incorporated more of their suggestions, and taken on more of their challenges.

Angelika Kratzer was much more than an advisor. Her conviction that I had something useful to say, especially in the early stages of this project, was a huge motivation. I will miss our long conversations, and her kind and firm way of explaining what's what. These talks changed the way I think and work.

Lisa Selkirk took me under her wing early on, and made me feel at home among the prosody crowd at UMass and beyond. In thinking out problems, she always encouraged me to find a hat and hang it somewhere. Her boldness of analysis is something that I still strive for.

Seth Cable has an uncanny ability to break unmanageable problems into manageable pieces. This is a service in high demand, and one that I availed myself of more than my fair share of. I'm grateful for his enthusiasm, attention to detail, care with data, and most of all his generosity.

Adrian Staub was a spectacular outside member, and I'm grateful for his detailed reading of the work and his insightful questions about the data and generalizations within. Adrian also took the time to help me work through a statistical analysis

which, although it didn't find a place in the thesis, was extremely helpful to my understanding of statistical methods.

Meeting with Jim Huang was always a pleasure, and our discussions led to major revisions in my analysis of Mandarin *-ne*. Beyond serving as a consultant on my committee, Jim also went out of his way to connect me with colleagues in China, and to invite me to present at a Harvard workshop, both to the benefit of the dissertation.

Many others, at UMass and beyond, have contributed their thoughts and feedback to this project. These people include: Klaus Abels, Aoju Chen, Chris Davis, Emily Elfner, Tom Ernst, Donka Farkas, Kai von Fintel, Lyn Frazier, Chloe Chenjie Gu, Christine Gunlogson, Martin Hackl, Nancy Hedberg, Irene Heim, Caroline Heycock, Li Julie Jiang, Kyle Johnson, Hans Kamp, Ezra Keshet, John Kingston, Haixia Man, Barbara Partee, Chris Potts, Kyle Rawlins, Floris Roelofsen, Mats Rooth, Philippe Schlenker, Roger Schwarzschild, Radek Šimík, Juan Sosa, Yasutada Sudo, Anna Szabolcsi, Satoshi Tomioka, Maziar Toosarvandani, Hubert Truckenbrodt, Michael Wagner, Yimei Xiang, Kristine Yu, Malte Zimmermann, and audiences at Harvard, MIT, Stanford, Barcelona, SALT 22, WCCFL 30, GLOW 35, NACCL 23 and WPSI 4.

For help with judgments, I am deeply grateful to Martina Achieng', Rui Guo, Chloe Chenjie Gu, Masashi Hashimoto, Misato Hiraga, Li Julie Jiang, Angelika Kratzer, Chi-Ming Louis Liu, Xiaoxia Ma, Haixia Man, Milton Joshua Obote, Ming Shao, Radek Šimík, Satoshi Tomioka, Martin Walkow, and especially, Bitian Zhang.

The department at UMass is a special place, where people from all over the world come together to engage the hardest problems in linguistics with creativity and a collaborative spirit. Building and maintaining this tight, supportive community has been the work of many generations, but a few of the people who particularly contributed to my feeling at home and having a great time were: Kathy Adamczyk, Rajesh Bhatt, Seth Cable, Chris Davis, Amy Rose Deal, Meg Grant, Clint Hartzell, Kyle Johnson, Angelika Kratzer, Suzi Lima, Barbara Partee, Aynat Rubinstein, Anisa Schardl, and

Lisa Selkirk. Also, thanks to my cohort, Anisa, Chloe, Emerson, Muhammad, and Vera, for all the good times.

Aside from UMass, there are two other special linguistics programs I'd like to mention. The MIT linguistics department, where I finished writing the thesis, was an amazing place to work and learn. I especially want to thank the participants in my fall 2013 seminar on information structure for being such a wonderful class, and pushing me to understand discourse structure better. I'm also grateful to the faculty, for welcoming me and offering their advice and support, especially David Pesetsky, Martin Hackl, Sabine Iatridou, Kai von Stechow, Irene Heim and Norvin Richards. Second, I owe a deep gratitude to the department that introduced me to linguistics, UC Santa Cruz. Their phenomenal undergraduate program nestled in the redwoods was where I learned the thrill of finding puzzles, formulating theories, and asking about their consequences. People there who contributed to my development as a linguist include Judith Aissen, Sandy Chung, Donka Farkas, Jorge Hankamer, Jim McCloskey, Paula Menéndez-Benito, and Jaye Padgett.

This research was assisted by a Mellon/ACLS Dissertation Completion Fellowship.

I dedicate this work, with love, to family. To my family in China, for taking me in, and putting up with me. To John and Ilona, for their endless enthusiasm and support. To Nuria, for always pushing to get to know me better, and helping me to understand myself. To Danuta, for showing me a world of possibilities. To Michael, for helping me think through the details of practically every problem I've ever worked on, and always pushing me in the right direction. Finally to Tiantian, for more than words of any language can express.

ABSTRACT

CONTRASTIVE TOPIC: MEANINGS AND REALIZATIONS

SEPTEMBER 2014

NOAH CONSTANT

B.A., UNIVERSITY OF CALIFORNIA, SANTA CRUZ

M.A., UNIVERSITY OF CALIFORNIA, SANTA CRUZ

Ph.D., UNIVERSITY OF MASSACHUSETTS AMHERST

Directed by: Professor Angelika Kratzer

This dissertation develops a theory of contrastive topics (CTs)—what they mean, and how they are realized. I give a compositional semantics for CT constructions, built on the idea that CT marks anaphora to a complex question in the discourse. The account allows us to maintain an inclusive view of what counts as a contrastive topic, making reasonable predictions about sentences with CT phrases of difference types, in various combinations, and across various speech acts. Empirically, the dissertation focuses on contrastive topic marking in English and Mandarin Chinese. In English, CT phrases are typically realized with a “rising” prosody. I offer an explicit model that predicts the intonational features of English sentences containing contrastive topics. In Mandarin, sentences with CTs often exhibit the discourse particle *-ne*. I provide a detailed description of the particle’s distribution, and offer the first sustained argument that *-ne* is a CT marker.

TABLE OF CONTENTS

	Page
ACKNOWLEDGMENTS	iv
ABSTRACT	vii
LIST OF FIGURES	xii
CHAPTER	
1. INTRODUCTION	1
1.1 Overview	1
1.2 Structure of the Dissertation	8
2. CONTRASTIVE TOPIC	11
2.1 The Potluck	12
2.1.1 Conventions for Prosodic Transcription	13
2.1.2 Contrastive Topic and Exhaustive Focus	16
2.2 A Mapping Principle	18
2.3 The d-Trees Model	28
2.3.1 Alternative Semantics	28
2.3.2 QUD Stacks, Discourse Strategies, and d-Trees	31
2.3.3 CT-Values and CT-Congruence	35
2.4 Properties of CT	47
2.4.1 Resists Thoroughly Exhaustive Answers	48
2.4.2 Resists Maximal Elements	51
2.5 Japanese CT <i>-wa</i>	52
2.6 CT in Non-Declaratives	56
3. THE TOPIC ABSTRACTION ACCOUNT	60
3.1 Challenges for Buring 2003	61
3.1.1 Formal Implementation	61
3.1.2 Conceptual and Interface Problems	62

3.1.3	CT Questions	64
3.1.4	Island Sensitivity	71
3.1.5	Multiple CT	75
3.1.6	CT Position	83
3.2	The Topic Abstraction Account	84
3.2.1	Question-Answer Congruence	85
3.2.2	Nested Focus Values and Sorted Questions	88
3.2.3	Topic Abstraction	94
3.2.4	CT Raising	99
3.2.5	Broad Assessment	107
3.3	CT Questions	108
3.4	Island Sensitivity	116
3.5	Multiple CT	123
3.6	In Defense of a Unified Account	131
3.6.1	Sentential CT as a Limiting Case	132
3.6.2	Constraints on Final and Repeated Answers	136
3.6.3	Cross-Linguistic Support	146
3.7	Other Configurational Approaches	149
3.7.1	Comparison with Tomioka 2010b	150
3.7.2	Comparison with Wagner 2012	155
3.7.3	Side-by-Side Comparison	162
4.	CT-MARKED QUANTIFIERS	164
4.1	Referential vs. Quantificational Understandings	165
4.2	The Problem for GQ Accounts	166
4.3	The Type-e Solution	171
4.4	Which Quantifiers Allow Type-e Meanings?	174
4.5	Support from Equatives	178
4.5.1	The Equative Diagnostic and How it Works	178
4.5.2	Features of the Equative Diagnostic	181
4.6	Support from Supplements	186
4.6.1	Background on Supplements	186
4.6.2	Nominal Supplements	187
4.6.3	Relative Clause Supplements	190
4.6.4	Other Supplements	192
4.7	Discourse Referents and Type-e Meaning	193
4.8	Implementing the Type-e Account	198
4.9	CT and Scope	203

5. ENGLISH CT PROSODY	212
5.1 Realizing CT-Marks and CT Configurations	213
5.1.1 Problems for CT-Marking Theories	215
5.1.2 The Task for Configurational Theories	221
5.2 CT Operator as IntP Clitic	228
5.3 Factors Affecting the Boundary Position	230
5.4 Scope-Prosody Correspondence	237
5.4.1 The SPC Constraint	237
5.4.2 SPC vs. Focus-Prominence	238
5.5 Delayed Boundaries	245
5.5.1 Sentence-Final L-H%	246
5.5.2 Island-Internal CT	248
5.5.3 Constrained Variability	250
5.6 Multiple CT	254
5.6.1 Complex CT	254
5.6.2 Nested CT	258
5.7 Pressure to Raise	264
5.8 The Agreement Alternative	265
5.8.1 Questions for Agreement	267
5.8.2 Evidence of Phrasing Asymmetry	270
5.9 Predicting Accent Shape	278
5.10 Over- and Under-Extension of CT Prosody	280
5.10.1 Over-Extension: Complex Focus and Initial Adjuncts	280
5.10.2 Under-Extension: CT Questions	288
6. MANDARIN -NE AS CT	293
6.1 Background on Mandarin Particles	297
6.2 Surface Distribution of <i>-ne</i>	299
6.2.1 Positions <i>-ne</i> Occurs	299
6.2.2 Colloquial, Frequent, Optional	300
6.3 Topic-Marking <i>-ne</i>	305
6.3.1 Mandarin Topic Position	306
6.3.2 Kinds of Topics Marked by <i>-ne</i>	308
6.3.3 <i>-ne</i> Resists Exhaustive Foci	312
6.3.4 <i>-ne</i> Resists Non-Contrasting Topics	314
6.3.5 <i>-ne</i> Resists Maximal Elements	316
6.3.6 <i>-ne</i> Marks <i>if</i> -clauses, Resists <i>because</i> -clauses	319
6.4 Fragment Questions	326
6.5 Expectations for Sentence-Final CT	335
6.6 Question-Final <i>-ne</i>	338

6.6.1	Alternative Questions	340
6.6.2	Particle Questions	344
6.6.3	A-not-A Questions	351
6.6.4	wh- Questions	366
6.7	Declarative-Final <i>-ne</i>	376
6.7.1	Not X, Rather Y	379
6.7.2	Not Only X, Also Y	385
6.7.3	At Least X, If Not Y	391
6.7.4	<i>-ne</i> Resists Exhaustive Answers	399
6.8	Aspectual <i>-ne</i> vs. CT <i>-ne</i>	406
6.8.1	Aspectual <i>-ne</i>	407
6.8.2	<i>-ne_{ASP}</i> Occurs in Exhaustive Answers	415
6.8.3	<i>-ne_{ASP}</i> Occurs in <i>because</i> -Clauses	419
6.8.4	<i>-ne_{ASP}</i> is Lower than <i>-ne_{CT}</i>	421
6.8.5	<i>-ne_{ASP}</i> Occurs in Particle Questions	426
6.8.6	Haplology of <i>-ne_{ASP}</i> and <i>-ne_{CT}</i>	433
7.	TOWARD A FORMAL ANALYSIS OF MANDARIN -NE	437
7.1	<i>-ne</i> as Left-Peripheral CT Operator	437
7.2	<i>-ne</i> as IntP Clitic	441
7.3	Clause-Medial IntP Breaks and Pressure to Raise	443
7.4	Sentence-Final <i>-ne</i>	445
7.5	Prospects for Other CT Particles	451
8.	CONCLUSION	455
8.1	Overview	455
8.2	Remaining Work	458
	APPENDIX: NOTATIONAL CONVENTIONS	461
	BIBLIOGRAPHY	464

LIST OF FIGURES

Figure	Page
1.1 Senses of “Contrastive Topic”	4
2.1 Pitch track of “[PERSEPHONE] _{CT} ... brought [the GAZPACHO] _{Exh} .”	14
2.2 Pitch track of “[PERSEPHONE] _{Exh} brought [the GAZPACHO] _{CT} ...”	20
2.3 Pitch track of “[PERSEPHONE] _{Exh} brought it.”	22
2.4 Pitch track of “[PERSEPHONE] _{CT} brought one...”	23
3.1 Contexts for “Few of us had read the majority of the books.”	103
3.2 Empirical coverage of four theories of CT	163
5.1 Declination, adapted from Ladd (1984)	274
5.2 CT+Exh contour, from Liberman and Pierrehumbert (1984)	276
5.3 Exh+CT contour, from Liberman and Pierrehumbert (1984)	276
6.1 Frequency of <i>-ne</i> in different corpora	302
6.2 Topics marked by <i>-ne</i> in <i>Rickshaw Boy</i>	310
6.3 Distributions of <i>-ne</i> , <i>zài</i> and <i>-zhe</i>	408
7.1 Comma usage following adverbial topics with and without <i>-ne</i>	442
A.1 Conventions for marking problematic examples	461
A.2 Glossing abbreviations	463

CHAPTER 1

INTRODUCTION

1.1 Overview

What are CONTRASTIVE TOPICS, and why do we care? The answer to the first question depends on who you ask, but everyone who’s used the term would probably at least agree that the following bolded phrases are contrastive topics:

(1) **Ukelele**, I studied formally. **Accordion**, I learned on my own.

The reason we care is that languages care. Languages do special things with contrastive topics. For instance, the fact that *accordion* appears sentence-initially in (1) is connected to its status as a contrastive topic. In another context, this word order would be unusual. For example, while (2a) works as a bitter opening to a beginner’s guide to the accordion, (2b) feels strange:

(2) a. I never had a book like this. I learned accordion on my own.

b. I never had a book like this. ??Accordion, I learned on my own.

Let’s build a quick theory of what makes (1) good and (2b) bad. Suppose that moving an object to the front of an English sentence requires that the object be a contrastive topic, and thereby demands that it have a particular interpretation. But what is this interpretation? Here’s a first guess. What makes *accordion* a contrastive topic in (1) is that the sentence is “about” the topic of the accordion, and that the speaker is contrasting this topic with a different topic—in this case, the ukelele. In (2), on the other hand, there is no contrast being drawn between *accordion* and anything else. Since it isn’t a contrastive topic, it can’t be fronted.

Some variant of this theory is no doubt needed to account for the availability of the English fronting (or TOPICALIZATION) in (1), and its unavailability in (2). However we won't pursue the goal of formalizing this theory further here. While that is an important project, making such a theory explicit will likely depend on being able to clearly identify what a sentence is "about", and this is a notoriously difficult task (cf. Reinhart 1981, McNally 1998).¹

Interestingly, there is a broader notion of contrastive topic that covers not only phrases like *accordion* in (1), but also the bolded phrases in (3–5). In this dissertation, we'll be concerned with contrastive topics (CTs) in this broader sense.

(3) I studied ukelele formally, but I learned **accordion** on my own.

(4) A: Did you learn to play ukelele and accordion on your own?

B: I learned **accordion** on my own... (Ukelele, I learned formally.)

(5) A: Can you play all these instruments?

B: I can play **most** of them... (I still haven't learned the trombone.)

B': I can't play **all** of them... (But I can play most...)

B'': I can **pretend**...

Two things are remarkable about this more inclusive sense of the term "contrastive topic". The first is that languages show sensitivity to this broader notion. Consider that English speakers naturally render all the bolded phrases in (1) and (3–5) with a distinctive intonation pattern. We'll look at the details of this intonation contour shortly, and much of the dissertation will concern its meaning and distribution. The second remarkable fact about this wider set of examples is that—building on work by

¹For further evidence that natural languages are sensitive to a notion of "aboutness" at the sentence level, see the extensive literature on Japanese thematic *-wa* (of which Heycock 2008 provides an overview), as well as McKenzie's (2012: §3) work on switch reference in Kiowa and other languages.

Büring (2003) and others—we can give an attractive unified account of how these CT phrases are interpreted that doesn't rely on any definition of “topic” or “aboutness”.

To a first approximation, the pragmatic core shared across all of these examples is “partial resolution”. Each statement resolves some issue related to the contrastive topic phrase, but simultaneously fails to resolve another salient issue. We'll spell out this intuition formally in chapter §3, where the proposal is that a contrastive topic marks anaphora to a complex multi-part question.

It is important to be aware of a rift among present-day researchers as to how the term “contrastive topic” is used. The two camps correspond to the two senses we've already considered. Some understand the term compositionally, as in “a topic that contrasts”. This is the narrow sense we started out with, that crucially depends on some independent notion of topicality—whether syntactic, semantic, or pragmatic.² Authors using this terminology include Krifka (2007), Vermeulen (2009, 2011, 2012), and Neeleman and Vermeulen (2012). On the other side of the rift, researchers understand contrastive topic as its own basic information structure category, independent of any notion of “topic”. Authors in this camp include Büring (2003), Gyuris (2002, 2008, 2009, 2012), and Tomioka (2010a, 2010b). For these authors, the definition of “topic” is irrelevant to a theory of CT.³

In the end, both categories are important, and the names we apply to them are inconsequential. This dissertation examines the more inclusive category covering all the examples in (1) and (3–5), and follows Büring in using “contrastive topic” to describe it. Note that even those who give the term a narrower meaning can still subscribe to the claim that the broader category is relevant to natural language and demands

²Usually, following Reinhart (1981) “topic” is defined roughly as “the entity that the sentence adds new information about”. The term ABOUTNESS TOPIC refers specifically to topics in this sense.

³Some, including McNally (1998) and Büring (2003) go as far as suggesting that grammar may not need to reference any definition of “topic” along the lines of the entity that a sentence is about. Others, including Tomioka (2010a) and Gyuris (2012) still allow a place for aboutness topics (also called “thematic” topics), but maintain that not all contrastive topics are aboutness topics.

analysis. For instance, Büring’s CTs correspond directly to what Krifka (2007: §6.2) identifies as DELIMITERS, describing the class as follows: “What [delimiters] have in common is that they express that, for the communicative needs at the current point of discourse, the current contribution only gives a limited or incomplete answer.”

Figure 1.1 illustrates how the two camps label the same divisions of the same space. The labels in italics, which we’ll be ignoring, construe CTs as a subset of aboutness topics. The bold labels, which we’ll be adopting, understand CTs as a larger class, only partially overlapping with aboutness topics. Two corollaries to take away are: (i) this dissertation is either about contrastive topics or delimiters, depending on who you ask, and (ii) anything that anyone has called a CT will qualify as a CT for us.

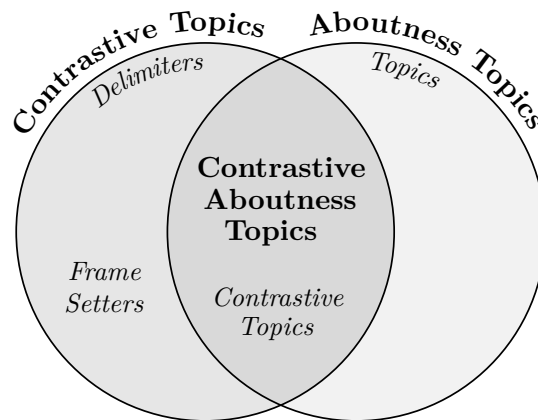

Figure 1.1: Senses of “Contrastive Topic”

Bold labels show the terminology we’ll be using, in line with Gyuris (2012) and others. *Italics* labels show Krifka’s (2007) terminology, with its narrower construal of CT.

We’ll see that a range of genetically and geographically diverse languages encode “partial resolution” meanings that are on a par with the contribution of the English intonation contour in the examples above. For instance, Japanese famously marks contrastive topics with the particle *-wa*, as in (6) and (7) below. (See the Appendix for glossing abbreviations and other notational conventions.)

- (6) John-ga **pai-wa** tabe-ta ga **keeki-wa** tabe-nak-atta.
 John-NOM pie-CT eat-PAST but cake-CT eat-NEG-PAST
 ‘John ate the *pie*, but he didn’t eat the *cake*.’ (Fiengo and McClure 2002: 30)
- (7) A: How much does a new hybrid car cost?
 B: **Nimangosen-doru-wa** suru.
 25,000-dollar-CT cost
 ‘It costs at least *\$25,000*...’ (Tomioka 2010a: 120)

The goal of this dissertation is to build a model of how CT realizations are connected to CT meanings cross-linguistically. On the meanings side, we can ask: what are the semantic/pragmatic boundaries to what languages treat as CTs, and how should CT-hood be represented formally? To take a specific example, what exactly is it that *the pie* and *\$25,000* have in common in (6) and (7)? In chapter §3, I’ll propose an explicit structural definition of CT-hood within a compositional semantic framework. I claim that CT phrases are focused phrases (in the sense of Rooth 1985) that associate with a special abstraction operator in the left periphery of a sentence. This “CT operator” has the effect of creating nested “set-of-questions” meanings, which are used to mark anaphora to complex multi-part questions. So, in a nutshell, CTs mark the presence of complex questions in the discourse. This analysis—which I dub the TOPIC ABSTRACTION account—covers a wider range of examples, with a more diverse range of meanings than have previously been treated together. In particular, we’ll see that this definition allows both the possibility of CT phrases in questions, as well as CT phrases corresponding to entire sentences. And, as it turns out, natural languages do indeed extend their CT-marking mechanisms to these cases.

Given a formal account that derives CT meanings from a dedicated structural configuration, we’re left with the question of how to map this structure onto a given realization pattern in a given language. Part of what makes studying CT across languages so interesting is the diversity of effects that CT meaning can have on a

sentence’s realization. These include (i) prosodic effects on pitch movements and phrasing, (ii) syntactic effects, and (iii) morphological effects, whereby specific particles are introduced. No theory of CT to date has tied together these two halves of the overall picture—on the one hand, giving an explicit syntax/semantics for CT constructions, and on the other hand, deriving distinct CT realizations from a common structure. In chapter §5, I take a step towards this goal by offering an explicit model of the syntax-phonology interface that can explain how CT constructions (as formalized on the topic abstraction model) come to be spelled out with their characteristic prosody in English. A key feature of the account is the claim that English realizes the left-peripheral CT operator with overt tonal material, as a rising tone.

The idea that CT phrases are associated with a potentially overt operator in the left periphery of the sentence is new.⁴ On this view, CT constructions are structurally analogous to *wh*- constructions, where (on the standard analysis) a question operator in complementizer position associates with a *wh*- phrase in the clause, which may move or stay in situ depending on the language.⁵ One consequence of this view is the expectation that we will find languages with overt CT morphemes that surface at a distance from the CT phrase. In English, the rising tonal clitic posited in chapter §5 is just such a morpheme, occurring sentence-finally in “rise-fall-rise” sentences like (4) and (5) above. However some readers may not be convinced of the morphemic status of this tonal movement, viewing (English) prosody as holistic “tunes”, or as the product of an independent module of grammar that builds on the output of the morpho-syntactic component. In this case, it is crucial to look for corroborating evidence of CT operator morphemes from other languages.

⁴For earlier analyses that assume a CT operator, but with no overt realization, see Tomioka (2010b), Davis (2010) and Wagner (2012).

⁵See Katz and Postal (1964) and Baker (1970) for the roots of this widely accepted analysis.

The final chapters of the dissertation locate this evidence in Mandarin Chinese. The Mandarin discourse particle *-ne* occurs in two positions: marking sentence-initial topics, as in (8), and sentence-finally, as in (9). While the topic-marking uses are generally recognized as a CT marker, there is no consensus on how the sentence-final uses should be analyzed, despite extensive discussion in the Chinese literature. I argue that like topic-marking *-ne*, sentence-final *-ne* can convey CT meaning. In this regard, the Mandarin particle shows a remarkable parallel to the English L-H clitic that surfaces either directly marking a topic, as in (1) and (3), or sentence-finally in cases like (4) and (5) that contain a CT and no other focal material.

- (8) Māma měi-tiān wǎnshang hěn wǎn cái huí-jīā.
 mom every-day night very late only.then return-home

Bàba ne, gāncuì jiù bù huí-lái.
 dad CT simply just not return-come

‘Every day mom doesn’t come home until late.

(And) dad, doesn’t even come back at all.’ (Shao 1989: 174)

- (9) Context: Giving advice on growing a medicinal herb in your yard.

Zhìshǎo **liǎng nián** cái néng shōu **ne**, kěnéng děi sān nián.
 at.least two year until can collect CT maybe need three year

‘It’ll be at least two years before you can use it, maybe three years.’

(web example)

From the perspective of CT theory, Mandarin *-ne* is important for at least two reasons. First, unlike CT particles discussed in the previous literature, *-ne* often appears sentence-finally, at a distance from the CT phrase. Thus, *-ne* is a good candidate for a direct realization of the CT operator posited in chapter §3. Second, *-ne* is ubiquitous in questions, and the use conditions on these questions fall in line with the predictions of the topic abstraction account. This is support both for the general claim that CT meaning is compatible with questions, and for the topic abstraction model.

1.2 Structure of the Dissertation

The dissertation is organized into thematic halves: “meanings” and “realizations”. The first half (chapters §2–4) focuses on issues in the formal semantic/pragmatic analysis of contrastive topic. The second half (chapters §5–7) addresses how CT is realized, with attention to English prosody and the Mandarin particle *-ne*. I provide a brief synopsis of each chapter below.

Chapter §2 introduces the central examples, formalisms and terminology that will play a role in our discussion of contrastive topic. I offer initial arguments in favor of the view that a wide range of examples can and should be treated under a unified theory of CT. This unifying move follows in the spirit of the classic accounts of Jackendoff (1972) and Büring (2003), but runs contra to a recent proposal by Wagner (2012). After outlining the basic goals of a theory of CT, I present Büring’s (2003) “d-trees” model, which serves as a point of reference for further discussion.

Chapter §3 presents the TOPIC ABSTRACTION model, a new theory of the syntax and semantics of CT constructions. In line with recent work in the cartographic tradition, the account maintains that contrastive topic phrases are associated with a functional head—the “CT operator”—in the left periphery of the sentence. I claim that CT phrases are uniformly interpreted in this position, either via base-generation, or by raising there through overt or covert movement. The discourse meaning of CT constructions is encoded in the semantics of the CT operator. Building on Rooth’s (1985) alternative semantics, the operator has the effect of creating a set of NESTED focus alternatives. This allows us to reduce CT meaning to a special case of focus anaphora. While typical cases of focus involve anaphora to a question, CT constructions mark anaphora to a set of questions. Beyond its conceptual appeal, the model addresses a number of empirical issues that challenge both classic and contemporary accounts. These include puzzles relating to (i) CT marking in questions, (ii) island-sensitivity, (iii) multiple CT, and (iv) CT movement.

Chapter §4 turns to CT-marked quantifiers, and addresses two major problems in their analysis. The first puzzle, as observed by Rooth (2005), is that when quantifiers like *some* and *most* are marked as contrastive topics, they typically set up contrasts between different sets of individuals, rather than different quantifiers. I propose to resolve this problem by allowing individual-denoting readings for a wider range of quantificational phrases than is usually assumed (e.g. by Reinhart 1997 and Winter 1997). One major important consequence of the analysis is that CT-marking can be used to diagnose the semantic type of quantificational expressions. As support for this new assessment of quantifiers, I present two corroborating diagnostics—using equatives and supplements. The second puzzle concerns the effect of CT-marking on quantifier scope. While the account in chapter §3 treats contrastive topics as always having widest scope, it is observed that quantificational CTs often scope under negation or other quantifiers. I resolve this seeming contradiction by showing that unlike quantifier raising, CT raising is never a scope-taking operation, since the semantics of the CT operator require that the type of moved phrase be identical to the type of the trace left below.

Chapter §5 addresses the question of how CT affects the realization of a sentence, and provides a detailed account how English CT prosody can be derived under the topic abstraction model. I propose that English lexicalizes the CT operator as a tonal morpheme (L-H) that cliticizes to the right edge of an intonational phrase. Furthermore, a scope-prosody correspondence constraint in the style of Hirotsu (2005) requires that the CT operator and its associated CT phrase occur within a single intonational phrase. The surface prosody is determined by the interplay between this and a potentially conflicting constraint asking that focused phrases (including CT phrases) be maximally prominent within a particular prosodic domain (cf. Truckenbrodt 1999). The final system of constraints generates an intricate set of predictions for how English CT sentences will be realized. I argue that these predictions are a

better characterization of the observable facts than previous accounts—in particular, we derive reasonable predictions about the position of each component of the CT intonation contour, and about the interaction of CT-marking and prosodic phrasing.

Chapter §6 turns to Mandarin Chinese, and gives the first in-depth substantiation of the claim that the Mandarin discourse particle *-ne* is a contrastive topic marker. Beyond this theory-driven goal, the chapter provides one of the more detailed descriptive characterizations of the particle to date, incorporating insights from the Chinese literature, as well as new generalizations and data from my own corpus and elicitation work. For each environment where the particle occurs (on topics, on fragment questions, and sentence-finally in questions and declaratives) I show that *-ne* is licensed by the presence of a complex set of questions in the discourse, which the marked utterance only partially addresses. Finally, the chapter presents the case for distinguishing two uses of *-ne* sentence-finally—one marking CT, and one marking durative aspect. Keeping these uses separate is critical if *-ne* is to show us anything about the properties of CT markers cross-linguistically.

Chapter §7 complements chapter §6 by sketching a formal analysis of Mandarin CT *-ne* within the topic abstraction framework. I propose that *-ne* spells out the CT operator, and that its linear positioning is subject to prosodic constraints similar to those governing the linearization of the English L-H clitic discussed in chapter §5.

CHAPTER 2

CONTRASTIVE TOPIC

This chapter provides an introduction to contrastive topic (CT). Since what qualifies as CT is a matter of some disagreement, we will—rather than starting from a definition—start by looking at some canonical examples, and gradually branch out to include a wider set of cases, based on certain shared core properties. In particular, we’ll provide an intuitive notion of how “CT phrases” function in the discourse, and we’ll see that, across a range of examples, English phrases with this function bear a distinctive intonation contour. The main goal at this stage is to reach a level of descriptive power whereby we can formulate a meaningful hypothesis about the nature of the relation between the distinctive prosody these phrases carry and the role they play in discourse.

Section §2.1 walks through a first example, and fixes the basic terminology and notation that will be used throughout the dissertation. Section §2.2 introduces the idea (due to Jackendoff 1972: §6.7) that there is a systematic correspondence between the pitch contour marking a constituent and the role this constituent plays in the surrounding discourse. We also identify various constructions that all plausibly fall under the domain of this mapping principle. Section §2.3 presents Büring’s (2003) account of CT, which allows a more refined view of what a CT phrase is, and leads to clear and reasonable predictions for each of the basic example types. Büring’s account will also serve as a point of departure for the upcoming chapter §3, which motivates a new theory of CT—the “topic abstraction” theory. Section §2.3 also reviews Rooth’s (1985, 1992, 1996) treatment of focus, and Roberts’ (1996) model

of discourse structure. These frameworks provide the foundation for both Büring’s theory and the topic abstraction theory. Section §2.4 turns to distributional properties of CT, focusing on two environments where CT marking is impossible. Section §2.5 is a brief introduction to the Japanese CT particle *-wa*, which is shown to display the characteristic behavior of a CT marker, and patterns with the English intonation contour that marks CT phrases. Finally, section §2.6 gives a few examples of CT in non-declaratives. These are of particular importance, since modeling the effect of CT in questions will turn out to be a challenge for Büring’s (2003) account.

2.1 The Potluck

Every year, Barbara hosts a potluck, and each guest is asked to bring a homemade dish to share. Unfortunately, this year, since I showed up late, I didn’t get to see who had brought what. So I asked Barbara to fill me in on the details. A few minutes into the conversation, we had this exchange:

- (1) A: What about Persephone and Antonio?
What did *they* bring?
B: Persephone brought the gazpacho.
Antonio, I’m not sure about.

Interestingly, this context guarantees that Barbara’s response will be pronounced with a particular intonation pattern. What exactly does this intonation convey, and why does this context demand its presence?

Before we can address these questions, we need to set some preliminary ground rules. This section introduces the basic terminology and notation that will help us to relate the prosody of examples like (1) to their meaning in context. In particular, we’ll lay down conventions for representing (i) the prosody of English examples, and (ii) the roles different constituents are playing in the discourse. As you may have guessed, we’ll see a striking connection between (i) and (ii).

2.1.1 Conventions for Prosodic Transcription

Focusing on the first sentence of B’s response, we can represent several prosodic features of the sentence as follows:

(2) PERSEPHONE ... brought the GAZPACHO.

This example contains two pieces of notation that will be used extensively throughout the dissertation. First, SMALL CAPS mark words that bear a high level of prominence. For example, speakers have an intuition that the words *Persephone* and *gazpacho* are “stronger” than any other words in the sentence.¹ This level of prominence is sometimes referred to as SENTENCE-LEVEL STRESS.

A second important fact about B’s response is that speakers have the sensation that there is a pause after the word *Persephone*. While this pause may be reduced in fast speech, it remains a salient feature of how (2) is pronounced and perceived.² Furthermore, this break in the sentence is accompanied by a specific low-rising pitch movement at the end of the word *Persephone*. In particular, the final syllable of this word transitions from a fairly low pitch to a mid-range pitch, as Figure 2.1 illustrates.^{3,4} I will indicate this low-rising pitch movement and the subsequent pause with the ‘...’ ellipsis symbol. Thus our two basic prosodic notations are as follows:

¹I assume that an abstract notion of relative strength is relevant to describing the phonology of most or all human languages, but that it is a language-specific matter what reflexes this feature will have on measurable indices like loudness, duration, pitch range and so on. With respect to English in particular, I assume that sentence-level stress is perceptually and cognitively salient, but not necessarily directly measurable.

²At the phonetic level, the abstract notion of a pause presumably translates into measurable effects. For example, in addition to the potential for an actual silence between words, there may be an increased duration on the last syllable of *Persephone*, and the transition to the next word may be characterized by various resetting phenomena such as pitch reset, or the blocking of phonological processes.

³The notation in the figure caption will be explained shortly.

⁴This and following pitch tracks have been simplified in various ways for the purposes of illustration. The recording it was generated from consisted of a sequence of [ma] syllables, rather than the

(5) **Core Elements of English ToBI**

- a. Pitch Accents: H*, L*, L+H*, L*+H, etc.
- b. Phrase Tones: H-, L-
- c. Boundary Tones: H%, L%

Each of these elements contributes a particular pitch shape, indicated as a sequence of one or more L(ow) or H(igh) tones. PITCH ACCENTS occur at positions of prominence: specifically, on the stressed syllables of words that are relatively prominent within the sentence. The ‘*’ symbol indicates the position of stress. Thus, H* represents a simple high pitch accent. Complex pitch accents are formed by combining two tones with the ‘+’ sign. L+H* represents a pitch accent that rises from L and reaches H at the stressed position. By contrast, an L*+H accent aligns the low tone with the stressed syllable, and the rise is realized on subsequent material.

PHRASE and BOUNDARY TONES occur at edges of domains, rather than positions of prominence. The ‘-’ and ‘%’ signs stand for domains of different sizes. The ‘-’ sign marks the edge of a relatively small domain, the PHONOLOGICAL PHRASE (PhonP). The ‘%’ sign marks the edge of a larger domain, the INTONATIONAL PHRASE (IntP). In English, edge tones occur at the right edges of these domains. Thus the right edge of a PhonP, which we can call a “PhonP break”, will have a single tone L- or H-. Similarly, IntP breaks will have L% or H%. Furthermore, since the larger IntP domain is made up of smaller PhonP domains, every IntP break will correspond to a PhonP break as well. Thus, for example, the end of every sentence will have both a phrase and a boundary tone—for instance L-L%. I will sometimes use the term “boundary tone” sloppily to refer to a combination of phrase tone and boundary tone proper.

This brief overview will suffice for our present purposes. For more details on ToBI and its relation to prosodic structure, see Pierrehumbert (1980) and Beckman and Pierrehumbert (1986). For more on the formalization of prosodic structure see

break the question into two smaller pieces, one about Persephone, and one about Antonio, and address them in turn. Thus, in an intuitive sense, Persephone and Antonio are *topics* of smaller issues, and they *contrast*. If B were feeling pedantic, she might have said “As for the issue of Persephone, she brought the gazpacho.”⁸ We will use the term CONTRASTIVE TOPIC (CT) as an informal label for phrases that have the function that *Persephone* has in (6).

The phrase *the gazpacho* is performing a different role in this discourse. Rather than defining a particular issue or question, this phrase serves as the answer to a question—specifically, the question of what Persephone brought to the potluck. If B were being truly pedantic, she might have uttered instead “As for the issue of Persephone, the answer to the question of what she brought is: the gazpacho.” We will refer to a phrase with the role of *the gazpacho* as an EXHAUSTIVE FOCUS (Exh). It provides the complete (exhaustive) answer to the question the sentence is addressing.

These new pieces of descriptive terminology are summarized in (7). It should be emphasized that these are intended only as rough, informal descriptive terms. They don’t yet suffice as definitional notions, and it is not yet clear whether such notions are relevant components of a formal theory of language.

(7) **Descriptive Terminology**

- a. CONTRASTIVE TOPIC: The phrase denoting what the question being addressed is about. Implies other questions about different topics.
- b. EXHAUSTIVE FOCUS: The phrase denoting the answer to the question being addressed.⁹

⁸While the ability to be marked by *as for* is sometimes promoted as a diagnostic for “topic-hood” (Gundel 1974, 1985; Reinhart 1981), I won’t rely on this test, since not every instance of CT passes it. For instance, the quantificational CT in the sentence “[ALL]_{CT} politicians aren’t corrupt...” resists any paraphrase with *as for*.

Using these terms, we can mark up B’s response with the shorthands $[\cdot]_{CT}$ for contrastive topic and $[\cdot]_{Exh}$ for exhaustive focus, as in (8). The notation itself makes no commitment as to whether these features are represented formally in the syntax. In fact, we will see that this is a controversial issue in chapter §3.

- (8) $[\text{PERSEPHONE}]_{CT} \dots \text{brought} [\text{the GAZPACHO}]_{Exh}$.
 $\text{L+H}^* \text{ L-H}\% \qquad \qquad \qquad \text{H}^* \text{ L-L}\%$

Now that we’ve taken a first look at how (8) sounds and at the pragmatic functions of some of its constituents, we can start to ask more interesting questions. To phrase the obvious question in general terms: Is there some systematic relationship between the surface realization of (8) and the discourse roles of its constituents? To what degree can we predict one from the other? The answers that I would like to argue for are “yes” and “to a large degree”. With respect to the relationship between English prosody and discourse structure, these answers follow in the footsteps of Jackendoff (1972: §6.7), Roberts (1996) and Büring (2003).

2.2 A Mapping Principle

In example (8), CT and Exh are pronounced differently. The CT phrase bears a “rising” intonation contour $\text{L+H}^* \text{ L-H}\%$, while the Exh phrase bears a “falling” contour $\text{H}^* \text{ L-L}\%$. This suggests the possibility that these prosodic contours are actually serving to mark these discourse roles. If so, the difference between CT and Exh is represented formally somewhere in the grammar of English. And if this is the case, studying the distribution of these intonation contours will inform our understanding of how to model this meaning difference formally.

⁹The expression “question being addressed” is used here to approximate the formal object described in Roberts’ (1996) system as the IMMEDIATE QUESTION UNDER DISCUSSION, as defined in section §2.3.

We can spell out a first hypothesis by postulating a direct mapping of contours onto discourse functions, as in (9). Of course, there are a number of details that remain to be spelled out. How are the notions of CT and Exh expressed formally? Where exactly do the pieces of the prosodic contour have to lie for a constituent to count as “marked” by that contour? However, the basic spirit of the analysis is clear enough. The models of Jackendoff (1972: §6.7), Roberts (1996) and Büring (2003) all build on a basic mapping principle of this sort.¹⁰

- (9) **Mapping Principle** (to be revised)
- a. Exh \iff H* L-L%
 - b. CT \iff L+H* L-H%

This analysis, even in this sketchy state, has the potential to cover a wide range of data. Let’s expand our view by considering some other combinations and orders that CT and Exh can occur in. In (10), we have our original example, where the CT phrase precedes the Exh phrase. I will refer to this type of example by the name “CT+Exh”. In (11), we find the opposite order “Exh+CT” is also possible.

¹⁰Much of the literature follows Jackendoff in referring to the Exh and CT contours in (9) as “A accents” and “B accents” respectively. I have avoided this terminology for several reasons. First, it invites conceptualizing of the contours as unitary prosodic objects, whereas we will see in chapter §5 that there is good reason to factor out the contribution of the different components of the contour. Second, the term ACCENT has now standardly come to refer to smaller objects, e.g. pitch accents.

rather than a full IntP break (L-L%). We will return to this difference in chapter §5, but for the time being we can ignore it.¹²

Just as the intonation has reversed, the discourse roles of Persephone and the gazpacho have been switched as well, as indicated by the $[\cdot]_{CT}$ and $[\cdot]_{Exh}$ marks. This is dictated by the preceding context. Since the discourse is aimed at resolving who brought the gazpacho and the salad, B’s statement is now construed as addressing one issue about the gazpacho, while another issue about the salad remains open. In this case, we could paraphrase B’s response as “As for the gazpacho, the person who brought it was: Persephone.” In sum, the alignment of prosody and discourse in (11) is just what we expect given the mapping hypothesis in (9).

Furthermore, as Jackendoff (1972) observes, these intonation contours are not assigned willy-nilly. If we try to use the contour in (10) in the context of (11), or vice versa, the results are infelicitous.¹³ These data points, given in (12) and (13), are a first indication that our mapping principle must be respected.

(12) A: What about the gazpacho and the salad?

Who brought *those*?

B: #[PERSEPHONE]_{CT} ... brought [the GAZPACHO]_{Exh}.
L+H* L-H% H* L-L%

¹²In terms of the overall pitch shape, the choice between L- and L-L% is irrelevant, since the contour is falling either way. To bring our mapping hypothesis up to speed, we could simply require that Exh constituents map onto the contour H* L-(L%).

¹³Throughout, I mark infelicity of an example in the given context with the ‘#’ sign. By contrast, the ‘*’ symbol will mark sentences that are unacceptable regardless of the context. In this latter case of uniform unacceptability, I make no attempt to indicate whether the source of the problem is syntactic or semantic in nature.

of these accounts are formalizations of the mapping principle we saw in (9). We will look at Büring’s model in some detail shortly. However before we do, there are a number of additional cases worth discussing. These cases are noteworthy because despite not being widely recognized as such, they also appear to be amenable to the style of analysis embodied by the mapping principle.

The first of these less well-known cases involves what I will refer to as “sentential CT”. Consider the example in (16). Here, I have marked B’s entire response as CT, in anticipation of the analysis it will receive in section §2.3 and chapter §3. However from our current perspective, it is difficult to say whether the sentence or any of its constituents meet the informal description we gave for CT. Specifically it isn’t clear whether any constituent within B’s response denotes what the question being answered is about.

(16) **Sentential CT**

A: Did anything interesting happen today?

B: [PERSEPHONE came over]_{CT}...
 L+H* L-H%

Nevertheless, there are a number of reasons to think that once we have the right notion of CT, (16) will be accounted for as a sub-type of lone CT. To begin with, the contour here is identical to the lone CT contour in (15), so the mapping principle would lead us to expect an analysis in terms of CT. But more than this, the discourse function of (16) shares certain core features with other examples of CT. For instance, just as in other CT-containing examples we’ve seen, B’s response is a partial answer to the question at hand. Specifically, the intonation here seems to convey that the speaker has not yet resolved the issue of whether anything interesting happened—and thereby implies an uncertainty as to whether Persephone coming over counts as interesting. Finally, we will see that several explicit models of CT, including both Büring’s (2003) and the account to appear in chapter §3, already extend to these

examples without any additional qualifications. Thus, there is an argument from Occam’s razor in favor of treating them in these minimal terms.

One last case that plausibly falls under the domain of our mapping principle is the case of sentences with more than one CT. I will refer to these as **MULTIPLE CT** examples. These are predicted to exist by Büring’s (2003) model of CT, although data of this kind are rarely discussed in the literature.¹⁷ Consider the following case:

(17) **CT + CT + Exh**

A: What did Persephone and Antonio bring these past few years?

B: [LAST year]_{CT} ... [PERSEPHONE]_{CT} ... brought [the GAZPACHO]_{Exh}.
 L+H* L-H% L+H* L-H% H* L-L%

In this example, both *last year* and *Persephone* display the rising CT contour. Furthermore, it seems reasonable that each one is a contrastive topic. In the first case, B’s response is addressing a question about last year, but there is a salient contrasting question about what was brought the other years. Secondly, relative to the question about last year, the speaker is only addressing one of several topics. She resolves the issue of what Persephone brought last year, but doesn’t address the contrasting issue of what Antonio brought. In this sense, *Persephone* also fits our general notion of what it means to be a contrastive topic. Finally, *the gazpacho* provides the answer to this one question of many, and displays the expected Exh contour.

Parallel to lone CT, we also find cases of multiple CT where the answer (e.g. “yes”) is not expressed by an overt Exh phrase. The following example illustrates.

¹⁷Büring (2003: 532) explicitly mentions the expectation of finding CT+CT in English, though doesn’t present any examples of this type. His theory also generates the possibility of CT+CT+Exh, although this prediction is not made explicit. See Yabushita (2008) for discussion of multiple CT data in Japanese.

(18) **CT + CT**

A: Did Persephone and Antonio bring vegetarian dishes these past few years?

B: [LAST year]_{CT} [PERSEPHONE]_{CT} brought one...
L+H* L- L+H* L-H%

Here again, *last year* and *Persephone* both seem to function as CT, identifying questions about last year and Persephone, as opposed to other salient questions. We could paraphrase the sentence as: “As for last year and Persephone: yes, she did.” The intonational facts are also broadly consistent with this view.¹⁸

We’ve now seen a number of classes of sentence where it appears that one or more phrase displays both CT meaning and CT prosody, repeated in (19). But what range of these configurations can and should be treated under a unified formal analysis of CT? This is a controversial question.

(19) **CT Constructions**

- a. CT + Exh
- b. Exh + CT
- c. Lone CT
- d. Sentential CT
- e. Multiple CT

Historically, CT+Exh has been viewed as the canonical case of contrastive topic, and some theories of CT limit themselves to these alone (e.g. Wagner 2012). However general consensus has followed Jackendoff in treating Exh+CT as comparable and aiming to model these cases in similar terms. The status of what I call lone CT is less widely agreed upon. Those who argue against unifying these with the previous

¹⁸Interestingly, the first CT phrase doesn’t display the entire L+H* L-H% contour, although we could potentially treat this as a reduced alternant. In the end, these sorts of variations suggest moving away from the idea of mapping a full intonational contour directly onto constituents. We will see an alternative approach that handles these variations more naturally in chapter §5.

cases refer to them by the name RISE-FALL-RISE (RFR), based on the shape of the pitch contour.¹⁹ Prominent analyses of RFR meaning have treated the contour as conveying the speaker’s uncertainty (Ward and Hirschberg 1985) or inability to make alternative claims (Constant 2012a).

The remaining types of examples have rarely been touched on in the literature. To my knowledge, there has been no discussion of sentential CT as a sub-type of lone CT, despite the fact that Büring’s (2003) model already makes reasonable predictions about these cases. Similarly, multiple CT (e.g. CT+CT and CT+CT+Exh) has not been widely discussed under any framework.

Our first order of business will be to present a more explicit model of CT meaning that can handle all the classes of example in (19). Büring’s (2003) model serves as an influential and elegant instance of this type. However, while I believe the analysis is on the right track, we’ll see that it runs into some serious problems. These include an inflexibility in its treatment of multiple CT, and an inability to handle CT in questions (which we will see evidence of shortly). To address these and other shortcomings, a novel theory of CT meaning is proposed in chapter §3—the “topic abstraction” account. This is an explicit theory that aims to unify across the classes in (19), as well as incorporating CT questions. Once we have this model as a reference point, we will come back (in section §3.6) to address specific arguments that have been made against such a unification.

¹⁹Some authors, following Ward and Hirschberg (1985), reserve the name “rise-fall-rise” for cases where the rising pitch accent is L^*+H as opposed to $L+H^*$. By contrast, I adopt the increasingly common practice of extending the name to either contour. Terminology aside, it is far from obvious that these variants differ robustly in meaning. Various conflicting claims of a categorical semantic contrast have been put forward by Ward and Hirschberg (1985), Pierrehumbert and Steele (1989), Pierrehumbert and Hirschberg (1990) and Steedman (2000, 2008). In line with Ladd (1980: 112) and Gussenhoven (1984), I suspect that any distributional difference between the two renditions can be understood in terms of a gradient paralinguistic effect where later accent alignment (L^*+H) is perceived as more “emphatic”.

To summarize, the mapping hypothesis in (9) already seems to make reasonable predictions across a wide range of examples. Let’s then move forward on the assumption that this simple principle is on the right track, and think about how to provide a formal implementation.

2.3 The d-Trees Model

This section introduces Büring’s (2003) influential model of CT meaning—the d-trees model. The account is situated within two larger frameworks. It builds on Rooth’s (1985) alternative semantics, and makes use of features of Roberts’ (1996) theory of discourse structure. We begin with a brief review of these frameworks, and then walk through the basic structure of Büring’s account in relatively informal terms. A more formal coverage of the theory is given in section §3.1.

2.3.1 Alternative Semantics

Modern compositional treatments of contrastive topic are built on top of Rooth’s (1985, 1992, 1996) alternative semantics, so a brief review of this framework is in order.²⁰ Rooth posits F-marks in the syntax on “focused” constituents—that is, constituents that generate semantic alternatives. On the interpretative side, a new dimension of meaning is added. Thus, in addition to an ordinary semantic value $\llbracket \cdot \rrbracket^o$, any natural language expression will have a FOCUS SEMANTIC VALUE $\llbracket \cdot \rrbracket^f$ or “F-value”. To a first approximation, F-values are calculated just like ordinary semantic values, with the exception that all F-marked constituents are varied, producing sets of contrasting meanings. Thus, the meanings composed in the focus dimension are ALTERNATIVE SETS—consisting of alternative meanings that could have been

²⁰One exception is Steedman’s (2000, 2008) work, which is framed in Combinatory Categorical Grammar (CCG). However more recently, Steedman (2013) has proposed a CCG account that also incorporates Rooth’s alternative semantics.

generated in the ordinary dimension if the F-marked phrases had been switched to denote something else.

The ordinary and focus semantic values in (20) illustrate a few simple cases. Expressions within denotation brackets represent syntactic structures—specifically, phrase structures at the level of “logical form” (LF). The denotations on the right-hand side refer to real-world objects or propositions. Thus, $\{ \text{John, Mary, Fred, ...} \}$ represents a set containing actual people. I use simple English translations as a shorthand for individuals, propositions and so on. Thus, I write the denotation of the sentence “John sneezed” as the proposition *John sneezed*. More formally, this proposition is the characteristic function of the set of worlds where John sneezed: $\lambda w.\text{sneezed}(\text{John})(w)$.

- (20) a. $\llbracket \text{John} \rrbracket^o = \text{John}$
 b. $\llbracket \text{John} \rrbracket^f = \{ \text{John} \}$
 c. $\llbracket [\text{John}]_F \rrbracket^o = \text{John}$
 d. $\llbracket [\text{John}]_F \rrbracket^f = \{ \text{John, Mary, Fred, ...} \}$
 e. $\llbracket [\text{John}]_F \text{ sneezed} \rrbracket^o = \text{John sneezed}$
 f. $\llbracket [\text{John}]_F \text{ sneezed} \rrbracket^f = \{ \text{John sneezed, Mary sneezed, Fred sneezed, ...} \}$

Beyond this technical contribution, Rooth offers a theory of how focus values are used to constrain the interpretation of an utterance in context. Specifically, Rooth (1996) defines a “squiggle” (\sim) operator to bind the focus alternatives. This operator has the effect of requiring a discourse antecedent that “fits” the focus value of the phrase it attaches to.²¹ I illustrate by way of example. Consider (21), where (a) gives the syntactic structure of a statement with focus on the subject.

²¹On Rooth’s actual implementation, the focus anaphor is realized as a silent syntactic variable, which serves as an argument to the squiggle operator. I’ve simplified the presentation here by foregoing any syntactic representation of the anaphor. A correspondingly simplified definition of the squiggle operator is assumed in chapter §3, again purely for convenience.

- (21) a. \sim $[[Ede]_F \text{ wants coffee}]$ (Logical Form)
- b. $[[Ede]_F \text{ wants coffee}]^f$ (Focus Value)
- = { Ann wants coffee, Bob wants coffee, ... }
- = Who wants coffee?

The focus value in (b) is the semantic input to the squiggle operator. This is the set of propositions that different people want coffee. Following Hamblin (1973), we can treat this set as a question meaning: “Who wants coffee?”. The effect of the squiggle operator is to relate this focus value to a discourse antecedent. We’ll see how this is implemented formally in chapter §3. But suffice to say that \sim will require that the context contain a question of the form “Who wants coffee?”. Thus, the prediction is that this sentence with focus on *Ede* would be a natural response to a question of who wants coffee, but not to a question of what Ede wants.

Of course, this theory doesn’t make any predictions until we couple it with a theory of how F-marking is reflected in the phonology. This is a complicated issue, but a good first approximation is that F-marked constituents must bear sentence-level stress. We’ll see a more refined implementation in chapter §5. For further discussion, see Selkirk (1984 et seq.), Truckenbrodt (1995, 1999) and Schwarzschild (1999).

Overall then, Rooth’s model provides a way of enforcing congruence between the prominence pattern of an utterance (e.g. “EDE wants coffee.”) and the kinds of discourse contexts it can appear in. However, it’s not yet clear how the difference we’ve seen between CT and Exh would be treated in this framework. Presumably both CT and Exh would be F-marked, since they both bear sentence-level prominence, and alternatives in both positions seem relevant to the overall computation. However, if both phrases are simply F-marked, what distinguishes CT+Exh from Exh+CT? There are (at least) two ways of moving forward here. One, following Büring (2003), is to introduce a second type of F-mark (call it a CT-mark) that directly encodes the difference. Another approach is to stick with Rooth’s pure F-marking system,

and differentiate CT from Exh in terms of how their focus alternatives are used in the computation. There have been several recent implementations of this second approach (Tomioka 2010b, Wagner 2012, Constant 2012b), and the account presented in chapter §3 falls under this category.

2.3.2 QUD Stacks, Discourse Strategies, and d-Trees

Büring’s (2003) account of CT is framed within Roberts’ (1996) model of discourse structure. I introduce the basic features of the model here, abstracting away from specific implementation details.

Roberts (1996) takes on the project of formally modeling facts about the shape of a discourse. These facts include, for example, information about what was said in what order, what has been agreed upon, and, perhaps most interestingly, what our intentions are for where the discourse is going—in other words, what we aim to achieve through this discourse, and how we aim to go about achieving it. The idea is to represent these facts by means of a structured object, which we can refer to as a DISCOURSE STRUCTURE.²²

The piece of a discourse structure that will be most directly relevant for us is the QUESTION UNDER DISCUSSION STACK (or QUD stack). This stack consists of a list of all the questions that are being addressed at a given point in the discourse. At the top of the list, we have the IMMEDIATE question under discussion, which we aim to resolve before doing anything else. Further down the list, we have older questions, which we are still in the process of answering. If the discourse proceeds in an orderly fashion, the more recent questions will help us to reach answers to the older, outstanding

²²Roberts originally uses the term “information structure” for this type of object. However, as she points out in an afterword to the classic paper (Roberts 2012a), the term has been widely used for a different purpose—referring to the information category of constituents within a sentence. An alternative proposed by Roberts (2012a) is the term “intentional structure”.

questions.²³ In this case, each QUD on the stack can be viewed as a sub-question of the questions below it on the stack.

Roberts' model inherits Stalnaker's (1978) view of conversation as narrowing down the set of possible worlds that we agree we might be in. Thus, the informational aim of a discourse is to answer what Roberts calls the "Big Question", namely "What is the way things are?". Any other question can be viewed as a sub-question of this larger question. Over the course of a discourse, questions will be added and removed from the QUD stack, but at any point, the stack represents the steps that connect our current position back to the Big Question. For instance, the QUD stack might at some point contain the elements in (22). This stack represents that we're talking about whether you like beets, with the larger goal of figuring out what foods you like, so that we might establish what you like in general, as part of our never-ending task of figuring out the way things are in the world.²⁴

(22) What is the way things are?

What do you like?

What foods do you like?

Do you like beets?

Of course, knowing whether you like beets isn't enough to resolve the larger question of what foods you like. After the beet question is removed from the QUD stack, we might add another question, say, "Do you like goat?". Roberts introduces the notion of a STRATEGY OF INQUIRY or DISCOURSE STRATEGY to describe the sequence of sub-

²³In fact, Roberts enforces a rather strict requirement that the complete answer to any question on the stack be a PARTIAL ANSWER to the next question down on the stack. A partial answer, in the sense of Groenendijk and Stokhof (1984), is one that resolves at least one alternative in the denotation of the question. Büring (2003: 517) suggests softening this restriction so that an answer need only shift the probabilistic weights among the propositions denoted by the question.

²⁴The logical *top* of this stack—where we add and remove elements—is at the typographic *bottom* of the list of questions in (22). This is by convention, and persists in Büring's d-trees notation, as introduced below.

questions through which we choose to address a given question. Importantly, there are any number of strategies by which we might pursue a question. For instance, if my goal is to figure out when the sun will rise tomorrow, I could start by asking: “Have you seen the sunrise recently?”. Or I could ask: “Do you have a newspaper?”. Choosing a good strategy is no easy feat. As Roberts put it:

As in a game, some strategies may be better, some worse; this is largely a matter of the rationality of the participants and not of linguistic competence *per se*. Whether strategies are effective involves, as well, an element of luck, as in any inquiry. (Roberts 2012b: 4)

Büring (2003) provides a convenient way of visualizing a sequence of moves in a discourse in terms of their question sub-question relationships, as encoded by the QUD stack. These diagrams are called DISCOURSE TREES or “d-trees”. The following d-tree illustrates one possible fleshing-out of a discourse that contains a state where the QUD stack is as in (22):

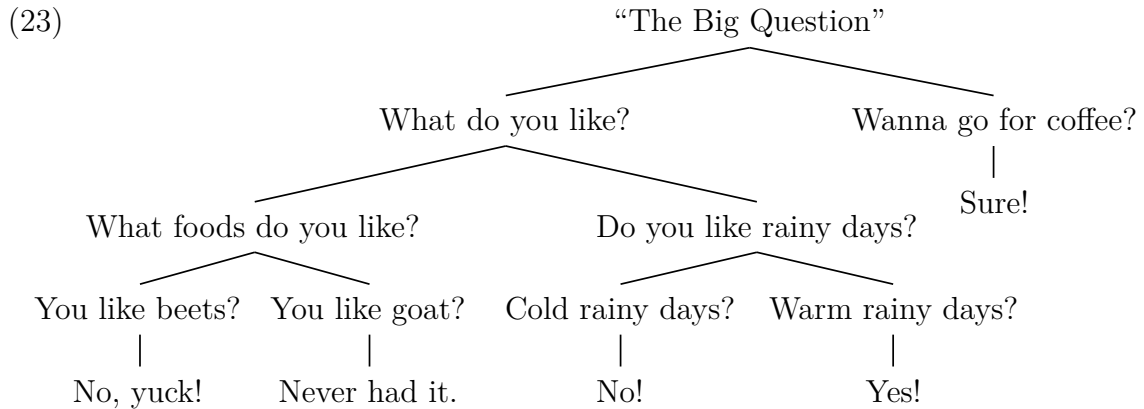

Within a d-tree, each node represents a DISCOURSE MOVE (in the sense of Carlson 1982)—either a question or an assertion. By convention, we understand the discourse as proceeding through the d-tree in depth-first traversal order with leftward material coming first, as illustrated below:

(24)

d-Tree Traversal

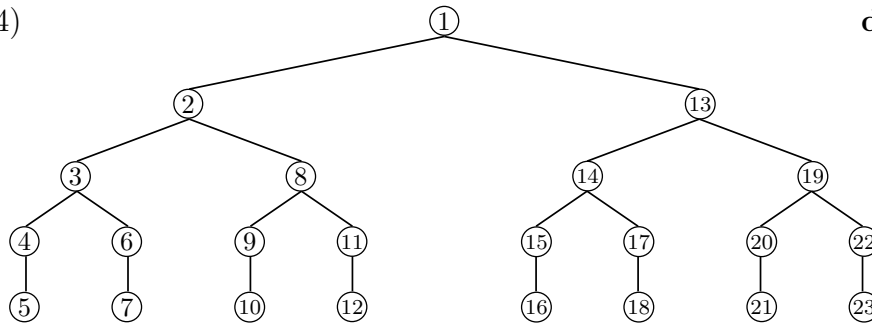

A crucial property of d-trees is that all the moves dominated by a question node aim to address that question. These moves collectively make up a discourse strategy for answering that question.²⁵ This requirement is enforced by a constraint that Roberts and Büring call **RELEVANCE**, defined by Büring as follows, where “the QUD” refers to the immediately dominating move in the d-tree.²⁶

(25) **Relevance**

(cf. Büring 2003: 518)

- a. an assertion A is relevant iff A addresses the QUD
- b. a question Q is relevant iff at least one answer to Q addresses the QUD

As is commonly assumed, following Hamblin (1973), a question is defined as the set of its logically possible answers. For an assertion to “address” a question, we can adopt Büring’s (2003: 517) requirement that the assertion shifts the probabilistic weights among the propositions denoted by the question. This is more lenient than Roberts’ conception of relevance, and may in fact still be too stringent, but will suffice for our purposes.²⁷

²⁵On Roberts’ implementation, a strategy for answering a question contains the question itself, as well as all dominated nodes (i.e. sub-questions of various depths, and their answers). I will sometimes refer to strategies more loosely as sets of sub-questions.

²⁶I have simplified Büring’s definitions by not referring explicitly to a specific d-tree. I also use the term “addresses” in place of Büring’s “answers”, so as not to suggest complete resolution of the question.

²⁷I have in mind dialogues like “A: Will it rain tomorrow? B: Maybe...”, where B’s response should be seen as addressing the question, despite apparently not providing any information that would get us closer to answering the question or even knowing which answer is more probable.

Overall, viewing discourse structure in terms of a hierarchy of question, sub-question and answer moves has proven to be an extremely beneficial development. This view, paired with Carlson’s (1982) view of discourse moves as being potentially implicit, is spelled out in detail in the work of van Kuppevelt (1995, 1996) and Roberts (1996), and has been a great boon to subsequent research on discourse-sensitive phenomena. Discourse structure, as represented by these models, is not just a convenient way for theorists to categorize properties of a conversation (although it excels in this function). The structure is claimed to be tangible for speakers as well, in the sense that natural languages are sensitive to it and can encode and reference its features directly.

2.3.3 CT-Values and CT-Congruence

We’re now ready to see how Büring accounts for the distribution of CT intonation. The first step is to enlist the mapping principle from section §2.2. This will enforce a correspondence between intonation contours and CT- or F- marks in the syntax, as follows:

- (26) a. $[\cdot]_F \iff H^* \ L-L\%$
 b. $[\cdot]_{CT} \iff L+H^* \ L-H\%$

How do syntactic CT- and F- marks contribute to the semantic computation? F-marking works the same way it did on Rooth’s system. Every expression has an F-value, which is the set of alternative propositions that we reach by (informally speaking) substituting different meanings for all F-marked constituents. What about CT-marks? Just as Rooth adds a new dimension of meaning for F, Büring introduces a dimension for CT, so that every expression now has three semantic values:

(27) **Dimensions of Meaning**

- a. $[[\cdot]]^o$ (Ordinary Semantic Value)
- b. $[[\cdot]]^f$ (Focus Semantic Value)
- c. $[[\cdot]]^{ct}$ (CT Semantic Value)

F-values provide a single level of abstraction. If the ordinary value of a sentence is a proposition, then its F-value will necessarily be a set of propositions—a question. Buring takes us one step further. The CT-value of a sentence is a set of sets of propositions—a set of questions. More specifically, CT-values are calculated by substituting *both* in the CT- and F-marked positions. However there is a crucial ordering at play. The F-marks are varied “first”, to create a question denotation, and “next” the CT-marked are varied, producing a set of alternative questions.²⁸ The recipe in (28) provides an informal description of how CT-values are computed. Readers wishing to refer directly to the formal definition may look ahead to page 61.

(28) **CT-Value Calculation** (informal)

- i. Replace F-marked phrases with variables \rightarrow a question
- ii. Replace CT-marked phrases with variables \rightarrow a set of questions

The informal derivation in (29) shows how to compute the CT-value of the expression “[Fred]_{CT} brought [the beans]_F”. The result is a set of questions asking what different people brought, including Fred himself.

²⁸On Buring’s formal implementation, which we’ll see in section §3.1, CT-values are calculated directly through composition rules, without the need for sequential operations. However this step-by-step recipe is a useful way of conceptualizing the formation of CT-values.

- (29) $\llbracket [\text{Fred}]_{\text{CT}} \text{ brought } [\text{the beans}]_{\text{F}} \rrbracket^{ct}$
- i. $[\text{Fred}]_{\text{CT}} \text{ brought } x. \rightarrow \text{What did Fred bring?}$
 - ii. $\text{What did } x \text{ bring?} \rightarrow \{\text{What did Ann bring? What did Bob bring? ...}\}$

Note that the choice of CT- vs. F- marking makes a difference. The reader can confirm that switching the CT- and F- marks in (29) results in a different CT-value—the set of questions $\{\text{Who brought the apples? Who brought the beans? ...}\}$.

The last step of the account is to use the CT-value of an utterance to constrain what kinds of discourses it can appear in. This is achieved through Büring’s “CT-congruence” condition, which I give a simplified version of here:²⁹

(30) **CT-Congruence** (informal, cf. Büring 2003: 520)

An utterance U with CT-marking answers a question within a strategy containing ≥ 2 questions from the set $\llbracket U \rrbracket^{ct}$.

This is the crux of the analysis. CT-marking indicates an answer to a sub-question within a strategy aimed at addressing some larger issue. Furthermore, the shape of the strategy—i.e. the form of the sub-questions it contains—is constrained by the placement of CT- and F- marks. More specifically, a CT-containing utterance answers the sub-question (Q_1) defined by its F-value, but doesn’t address at least one particular alternative sub-question (Q_2) within its CT-value. As sister sub-questions, Q_1 and Q_2 address a common larger issue. And while Q_2 is not currently under discussion, it crucially *will have been* under discussion by the time that larger issue is closed. All in all, then, CT-marking does just what we already intuited in section §2.1: it marks the existence of contrasting questions that result from making substitutions for the CT phrase.

²⁹Büring’s version requires that the other questions be *sisters* in a d-tree, rather than just “in the same strategy”. Recall that the notion of a strategy encompasses an entire sub-tree of a d-tree.

CT-values are complex, nested objects. Specifically, they are sets of sets of propositions—or equivalently, sets of questions. As we move forward, it will be useful to be familiar with several different ways of representing these nested objects. The following equality illustrates.

$$\begin{aligned}
 (31) \quad & \llbracket [\text{Fred}]_{\text{CT}} \text{ brought } [\text{the beans}]_{\text{F}} \rrbracket^{\text{ct}} \\
 \text{a.} \quad & = \{ \{ x \text{ brought } y \mid y \in D_e \} \mid x \in D_e \} \\
 \text{b.} \quad & = \left\{ \begin{array}{l} \{ \text{Fred brought the beans, Fred brought the pasta, ...} \}, \\ \{ \text{Mary brought the beans, Mary brought the pasta, ...} \}, \\ \dots \end{array} \right\} \\
 \text{c.} \quad & = \{ \text{What did Fred bring? What did Mary bring? ...} \} \\
 \text{d.} \quad & = \text{For each person, what did they bring?}^{30}
 \end{aligned}$$

Line (a) uses set abstraction notation (twice) to build a set of sets of propositions.³¹ Line (b) describes the same sets of propositions by listing their members—individual propositions. Line (c) rephrases each set of propositions as a question. Finally, (d) rephrases this entire list of questions as a single complex question. Note that each notation draws on English as a shorthand—either for a proposition, a question, or a set of questions.

Let’s see how CT-congruence plays out across a few different CT constructions. The predictions for a CT+Exh example are shown in (32). The prosodic features of the utterance are given in (a). By the mapping principle, these imply the LF shown at the top of (b), from which a CT-value can be derived. This CT-value implies that the utterance is answering a question within a discourse strategy containing two or more questions of the form “What did x bring?”. The d-tree in (c) illustrates one

³⁰In deference to colloquial English, I use *they* here and throughout as a gender-neutral singular pronoun.

³¹Following common practice, I allow the use of complex expressions on the left-hand side of the abstraction. For example, I write $\{2x \mid x \in \mathbb{Z}\}$ for the set of even numbers, where purists would insist on $\{x \mid \exists y [y \in \mathbb{Z} \text{ and } x = 2y]\}$.

strategy of this kind. As we've already observed, this is precisely the right kind of context to license CT+Exh. The Exh phrase *the beans* provides the answer to the immediate question under discussion (“What did Fred bring?”), and the larger discourse addresses contrasting questions about alternatives to the CT phrase (e.g. “What did Mary bring?”).

(32) a. FRED ... brought the BEANS. **CT+Exh**
 L+H* L-H% H* L-L%

b. [[Fred]_{CT} brought [the beans]_F]^{ct}
 = { What did Fred bring? What did Mary bring? ... }
 = For each person, what did they bring?

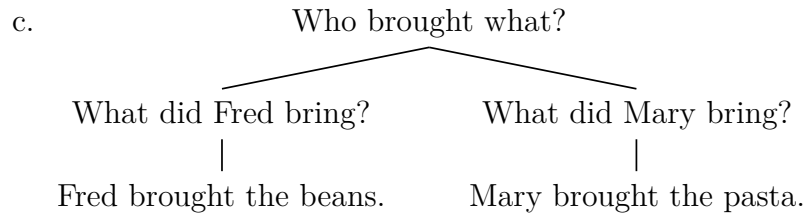

Exh+CT examples work similarly, as shown in (33). In fact, nothing in Büring’s account predicts any sensitivity to the order of the constituents. If the CT contour marks the object, then the object bears a formal CT feature, and we predict congruence to a strategy of questions varying in object position. Again, this fits with our observations from section §2.2 for where Exh+CT can be used.

- (33) a. FRED brought the BEANS... Exh+CT
 H* L- L+H* L-H%
- b. \llbracket [Fred]_F brought [the beans]_{CT} \rrbracket^{ct}
 = { Who brought the beans? Who brought the pasta? ... }
 = For each food, who brought it?
- c.
- Who brought what?

```

graph TD
    Root[Who brought what?] --- L[Who brought the beans?]
    Root --- R[Who brought the pasta?]
    L --- L1[Fred brought the beans.]
    R --- R1[Mary brought the pasta.]
  
```

It’s worth highlighting that the d-trees in (32) and (33) have the same root node, indicating that the two discourses share the overarching goal of establishing who brought what. A powerful feature of Roberts’ model that it explicitly represents not only the commitment of the speakers to reach this informational goal, but also the organizational decision about *how* to reach that goal. One strategy encodes a choice to pursue the issue “person by person”, whereas the other breaks up the same issue “food by food”. Extending Kuno’s (1982) terminology, I will sometimes refer to a discourse like (32) as “SORTING by people”.³²

Moving on, lone CT examples work cleanly as well, provided that we make one simple assumption about the denotations of yes-no questions. Consider the LF at the top of (34). What is its CT-value? The first step of the CT-value “recipe” is to create a set of propositions by varying any F-marked phrases—even if there are none.³³ This produces the singleton set { Fred brought something }. Next, we proceed as usual and vary the CT phrase to create a set of sets. The result is shown in (a) and (b).

³²This terminology has its roots in Kuno’s (1982) notion of a “sortal key”—the element that we are breaking up an issue according to.

³³This follows directly from Büring’s (2003: 539) formal implementation of CT-value composition, which we’ll see in section §3.1.

- (34) $\llbracket [\text{Fred}]_{\text{CT}} \text{ brought something} \rrbracket^{ct}$
- a. $= \{ \{ x \text{ brought something} \} \mid x \in D_e \}$
- b. $= \left\{ \begin{array}{l} \{ \text{Fred brought something} \}, \\ \{ \text{Mary brought something} \}, \\ \dots \end{array} \right\}$

Throughout, we've understood sets of propositions as questions, where each proposition corresponds to a possible answer to the question. So what question, if any, does a singleton proposition stand for? Following Büring (2003: 532) and others, let's assume that it stands for a polar question.³⁴ So for example $\{ \text{Fred brought something} \}$ is one representation of the question “Did Fred bring something?”. In this case, the CT-value from (34) is the following set of polar questions:

- (34 cont'd) c. $= \{ \text{Did Fred bring something? Did Mary bring something? ...} \}$
- d. $= \text{For each person, did they bring something?}$

Given this treatment of polar questions, the distribution of lone CT falls out exactly as we would hope. The sentence in (35a) has the CT-value in (b), and might appear in a discourse like (c). This is in line with our observations of lone CT's meaning from section §2.2.

³⁴While polar questions have traditionally been taken to denote sets containing both a positive and a negative alternative, a recent line of research argues for a distinction between what Krifka (2013) calls MONOPOLAR and BIPOLAR questions—where the former denotes a singleton set and the latter denotes the familiar twosome. See Biezma and Rawlins (2012) and Krifka (to appear) for further support for monopolar questions, beyond their applicability to lone CT. We'll also see evidence of a monopolar/bipolar ambiguity in Mandarin A-not-A questions in section §6.6.3.

- (35) a. FRED brought something... Lone CT
 L+H* L-H%
- b. \llbracket [Fred]_{CT} brought something \rrbracket^{ct}
 = { Did Fred bring something? Did Mary bring something? ... }
 = For each person, did they bring something?
- c. Which people brought something?
 / \
 Did Fred bring something? Did Mary bring something?
 | |
 Fred brought something. Mary brought something.

One final point about Büring’s (2003) model is that it places no restrictions on the size of constituents that can receive CT- and F- marks. If the marked phrases only cover a small piece of the sentence, the strategy implied will contain questions that have a lot in common. For example, the following sentence implies a strategy of questions “What does the ex-convict with the x shirt write in the garden?”³⁵

- (36) The ex-convict with the [RED]_{CT} shirt ... writes [POETRY]_{Exh} in the garden.
 L+H* L-H% H* L-L%

Conversely, when the marked constituents cover more of the sentence, the sister questions in the strategy can vary in more substantial ways. For instance, (37) is compatible with a strategy “What did each person do?”³⁶

³⁵This sentence is a corruption of two examples from Chomsky (1969) designed to make roughly the same point for sentences with a single focus.

³⁶The same intonation pattern is also compatible with narrow Exh on the object. More generally, the position of stress within a broadly focused phrase (either CT or Exh) is determined through the interaction of various phonological, syntactic and semantic factors. See the literature on “focus projection”, including Selkirk (1984, 1995), Schwarzschild (1999), Truckenbrodt (1999), Büring (2006), Féry and Samek-Lodovici (2006), and Wagner (2006b).

(37) [FRED]_{CT} ... [read a BOOK]_{Exh}.
 L+H* L-H% H* L-L%

In the extreme case, lone Exh and lone CT can cover the entire sentence. The former case, of a sentence with broad exhaustive focus, is sometimes referred to as a THETIC JUDGMENT.³⁷ A typical example is in (38). As Chafe (1974) observes (though not in these terms), Englishthetic judgments consisting of just a subject and a simple intransitive predicate have the main sentence stress on the subject:

(38) A: Why are you so happy?
 B: [FRED came over]_{Exh}.
 H* L-L%

Here, if the entire clause is F-marked in the syntax, the semantic F-value of the sentence will be the alternative set consisting of all propositions:

(39) \llbracket [Fred came over]_F \rrbracket^f
 = { It will rain tomorrow, Mary likes cats, ... }

This seemingly degenerate alternative set actually leads to a meaningful prediction about the use conditions of this sentence (and allthetic judgments) in discourse. When we pass this focus value as input to Rooth’s squiggle operator (defined formally in chapter §3), it will require simply the presence of some question in the discourse asking for a choice between multiple propositions, but with no restriction on the shape of the potential answers. In fact, this is precisely the type of question we have in (38). While a question like “Who wants coffee?” demands an answer of a particular kind, a question like “Why are you happy?” doesn’t (in a structural sense at least) exclude any proposition from standing as an answer.

³⁷This is as opposed to a CATEGORICAL JUDGMENT, which contains both a topic and a focus. See Kuroda 1972, Sasse 1987 and Ladusaw 1994 for discussion of the distinction and its grammatical reflexes.

Sentential CT examples have been less widely discussed (usually going by the name “rise-fall-rise”) and their relation to CT has typically gone unnoticed. But while Büring doesn’t mention these cases, his model both predicts their existence, and captures their distribution without additional stipulation. Consider the following example:

(40) A: Did anything interesting happen today?

B: [FRED came over]_{CT}...
 L+H* L-H%

If the pitch accent on Fred can mark broad CT on the entire sentence—which is plausible, by analogy to the sentential Exh case in (38)—then we can analyze this example as in (41) below. The CT-value in (41b) is different than the F-value we had in (39). Rather than the set of all propositions, we now have the set of all polar questions. Plugging this in to the CT-congruence condition, the prediction is again quite general, but not vacuous. The sentence is predicted to be an answer to one polar question within a strategy of contrasting polar questions that together address some larger issue. Thus, sentential CT conveys nothing more than what appears to be the immutable core of all CT meaning: partial answer-hood.

(41) a. FRED came over... **Sentential CT**
 L+H* L-H%

b. $\llbracket [\text{Fred came over}]_{CT} \rrbracket^{ct}$
 = { Will it rain tomorrow? Does Mary like cats? ... }
 = For each proposition, is it true?

c. Did anything interesting happen today?

When we consider a use of sentential CT in response to a particular question, we can phrase this general prediction in more concrete terms. Let's make the simplifying assumption that the only question under discussion in (40) is the overt question "Did anything interesting happen today?". In this case, the response "Fred came over..." is necessarily a partial answer to *that* question. In other words, speaker B has broken the question under discussion into a strategy of multiple sub-questions, and is only answering one of them, thereby making progress on the original question, but not resolving it. How can the proposition that Fred came over contribute towards an answer to the question, but simultaneously not resolve it? This can only be the case if the speaker thinks that Fred coming over potentially counts as interesting, but isn't entirely sure. The speaker takes the first step of establishing that Fred came over, but conveys that more work has to be done before the original question can be removed from the QUD stack. One natural, direct way to "finish the strategy" would be to address the contrasting sub-question "Is Fred coming over interesting?". This overall structure is shown in (41c). However, as usual, other strategies are possible as well. For example, speaker A might continue with the sub-question "Did anything more interesting than that happen?". Crucially, CT doesn't imply any particular strategy, just the presence of some multi-question strategy.

Of course, the simplifying assumption we just made is not always justified. Often, the immediate question under discussion is treated as part of some larger issue.³⁸ We can make this type of structure explicit with a discourse like (42), where speaker A starts by posing a large question, and then immediately narrows down to a sub-question. In this case, the question that B's use of CT marks a partial answer to is not A's most recent question "Did Fred come over?" (since it clearly is a complete

³⁸In fact, formally speaking, this is always the case, unless someone asks the Big Question outright. In practice though, we seem perfectly able to blind ourselves to this higher-level structure.

answer to that). Rather, B is providing a partial answer to the earlier question of why she is so happy.

(42) A: Why are you so happy? Did Fred come over?

B: [FRED came over]_{CT}... but that's not why I'm so happy...
L+H* L-H%

The strategies underlying sentential CT examples lack the internal symmetry that we've seen in other types of examples. This is no accident. Marking the entire sentence as CT is the only way we can mark congruence to a strategy of structurally unrelated questions. When CT is non-sentential, the questions within the implied strategy will necessarily share a skeleton in common, imposing a particular kind of predictability and order on the surrounding discourse. However we should by no means feel uncomfortable positing discourse strategies that are less constrained, as in (41c). Indeed, it would take extra stipulation at the level of Roberts' (1996) formalism to rule these strategies out, or extra stipulation within Büring's (2003) system to keep CT from marking congruence to them.

Overall, we've seen that Büring's (2003) d-trees theory elegantly captures the basic distributional facts of a range of CT-containing examples: CT+Exh, Exh+CT, lone CT and sentential CT. One notable feature of the account is that it never imposes a requirement of "topic-hood" on CTs. Arguably, this is a good thing. For one, it's notoriously difficult to define what a topic is (cf. Reinhart 1981, McNally 1998). For another, many CT phrases (i.e. elements that both exhibit CT prosody and give rise to CT-congruence) just aren't topics in any intuitive sense. For example, one would be hard pressed to demonstrate the topicality of the predicate in the following sentence:

(43) A: Did the students sign the petition?

B: They [WANTED to]_{CT}...
L+H* L-H%

2.4 Properties of CT

So far, the prospects look good for the hypothesis that natural language encodes notions like CT and Exh formally, and can signal constituents as fulfilling these pragmatic roles via dedicated realization patterns. Across a wide range of examples, it appears that English realizes CT with a L+H* L-H% contour and Exh with a H* L-L% contour. Furthermore, we've seen how to put some meat on the notions of CT and Exh using Büring's CT-values and CT-congruence.

Let's focus for the moment on CT marking. Do other languages have dedicated means of marking CT constituents? The answer we will eventually reach is that many languages do realize CT meaning in some form or other. But how do we know that a given marker in another language is conveying the same effect as English L+H* L-H%? And for that matter, why would we take the L+H* L-H% contour as the gold standard for CT-hood? What if the formal notion of CT is akin to formal notions like nominative case or subjunctive mood, which English only marks in a limited or sporadic fashion?

The intuitive notion of CT we began the chapter with in (7) is also a non-starter. It's not precise enough to make clear cuts. And in fact we've already seen that this informal notion breaks down in the case of sentential CT. By contrast, an explicit theory of CT meaning like Büring's has the advantage of making clear-cut predictions for which constituents can serve as CTs in which context. Such a theory gives us specific expectations for where CT can and can't be used, and thus has the potential to help us identify new CT markers in other languages. But at the same time, we would like to ground our theory in observable facts about what, cross-linguistically, languages actually mark as CT. So where to begin?

A good place to start is by observing a few specific properties that hold of CT in English, and that (luckily) turn out to hold of CT across a wider range of languages. These diagnostics can serve as useful checks that what we’re calling a CT marker in one language is on a par with what we’re calling a CT marker in another. The diagnostics can also play a second role in delimiting the space of adequate theories of CT. That is, they can help us to summarize key behavior of CT that we’d like a theory of CT meaning to account for.

So how does CT behave? I’ve listed below two properties that will turn out to be useful general diagnostics. The following sections go through these in turn.

- (44) a. CT can’t appear in exhaustive answers to the entire issue at hand.
b. CT resists marking maximal elements (e.g. *all*, *none*).

2.4.1 Resists Thoroughly Exhaustive Answers

All of the CT-containing examples we’ve seen so far have shared the property of being partial answers. In fact, the notion of partiality is integral both to the intuitive notion of CT we started with, and to the formal notion of CT-congruence in the d-trees model. If an answer addresses only one of several contrasting issues (each about a different topic), it is necessarily partial. A truly complete answer would simply resolve all of these issues, rather than taking them one at a time.

The contrast between partial and exhaustive answers is most directly visible in responses to yes-no questions. As (45) shows, CT is illicit on any direct answer that implies a resolution of the preceding question.³⁹ (Here and elsewhere, I resort to underlining to mark sentence-level stress on all-capital words like *I*.)

³⁹I’m aware of only one exception to this generalization. Fully-resolving answers to polar questions like the (b) forms in (45) can be CT-marked for a particular rhetorical effect. The effect is similar to responding with “Duh!” (which, incidentally also receives CT prosody, cf. Constant 2012a), implying something along the lines of “Why are you even asking? Isn’t it obvious?”

2.4.2 Resists Maximal Elements

Another distinctive feature of CT marking is that it resists maximal elements, as observed by Büring (1997a) and others. For example, the pair in (50) shows that the CT contour is licensed on *most* but illicit on *all*.⁴¹

(50) (Which train did they take?)

- a. [MOST]_{CT} of them ... took the [EARLY]_{Exh} train.
 L+H* L-H% H* L-L%
- b. #[ALL]_{CT} of them ... took the [EARLY]_{Exh} train.
 L+H* L-H% H* L-L%

There are various ways of accounting for this fact formally, but a common insight is that *all* fails as a contrastive topic because there is nothing it can contrast with to make the utterance non-resolving in the crucial way. First consider the role of *most* in (50a). While this utterance resolves the question of which train *most* of them took, it leaves unresolved a contrasting question with a different topic—the question of which train the *rest* of them took. In (50b) however, there can be no contrasting question of this kind. If our goal is to determine which train each person took, (50b) leaves nothing unresolved.

One important exception to this general rule is that maximal elements no longer resist CT when they appear in DOWNWARD-ENTAILING contexts (see Ladusaw 1980). These include occurrences under the scope of negation, as in the following example, adapted from Büring (1997a):

⁴¹The choice to mark the words *most* and *early* as CT and Exh, as opposed to marking the containing DPs, anticipates the upcoming analysis in chapters §3 and §4.

- (51) [ALL]_{CT} politicians aren't corrupt... (cf. Büring 1997a: 180)
 L+H* L-H%

The ability of CT to mark maximal elements only in certain scope configurations leads to a phenomenon known as SCOPE INVERSION, whereby the presence of CT forces one reading of a sentence that would otherwise be scopally ambiguous. Büring (1997a) discusses CT+Exh examples from German. The following example shows that the same effect arises under English lone CT (or “rise-fall-rise”). Note that intonation aside, either reading is possible here.⁴²

- (52) [ALL]_{CT} my friends didn't come... (Constant 2012a: 408)
 L+H* L-H%
- a. = ‘Not all my friends came.’ (not > all)
 b. ≠ ‘None of my friends came.’ (*all > not)

There are a number of issues that arise when we try to formally model the effect of CT-marking on quantificational elements. Specifically, it turns out to be challenging (i) to capture the general effect of CT-marking on quantifier scope, and (ii) to make the right predictions about what types of elements can contrast with CT-marked quantifiers like *most*. A fuller account of these effects is given in chapter §4.

2.5 Japanese CT *-wa*

Some languages, rather than realizing CT with an intonation contour, are said to have CT particles. These are discourse particles that typically attach to the CT phrase, or in some cases, mark a CT phrase at a distance. The most widely discussed case is that of Japanese contrastive *-wa*. This section provides a brief introduction to this

⁴²For this reason, (52) is a better illustration of English scope inversion than (51), which strongly prefers the CT-compatible reading regardless of the intonation.

particle, and shows that contrastive *-wa* has the basic properties we expect of a CT marker.

As observed by Kuno (1973), Japanese *-wa* has two distinct uses. In one case, contrastive stress is placed on the *-wa*-marked phrase.⁴³ This use is referred to as CONTRASTIVE *-wa*. In the other case, there is no contrastive stress associated with the marked phrase. In the Japanese literature, this second use is commonly referred to as “thematic” *-wa*. I’ll adopt the more neutral term promoted by Heycock (2008: 55)—NON-CONTRASTIVE *-wa*.

The degree to which the two uses of *-wa* are related is an interesting and much debated issue (see Heycock 2008, Tomioka 2010a and Vermeulen 2013, among others). However we don’t need to address it here. Let’s focus our attention on just the contrastive uses. As the following examples show, contrastive *-wa* marks phrases that match our intuitive notion of what it means to be CT. The first example is a case of CT+Exh, and the second is lone CT:⁴⁴

- (53) (Who ate what?) **CT+Exh**
- ERIKA-**wa** MAME-o tabe-ta (kedo ...).
 Erika-TOP beans-ACC eat-PAST but
 ‘[*Erika*]_{CT} ... ate [the *beans*]_{Exh} (but ...).’ (Tomioka 2010b: 123)

⁴³Actually, as Tomioka (2010a: fn. 3) points out, the contrastive stress can appear either on the preceding phrase, or on the particle itself. For simplicity, I will assume throughout that the first of these two options has been taken.

⁴⁴I gloss *-wa* as a topic marker (TOP) throughout, suggesting the possibility of unifying the contrastive and non-contrastive uses. However it won’t be relevant for our purposes whether such a unification would be attainable or even desirable.

- (54) (Did both Erika and Ken pass?) Lone CT
 ERIKA-**wa** ukat-ta.
 Erika-TOP pass-PAST
 ‘[*Erika*]_{CT} passed...’ (Tomioka 2010b: 120)

Also, like the English CT contour (L+H* L-H%), contrastive *-wa* extends to cases of sentential CT. For example:⁴⁵

- (55) (Was the weather good?) Sentential CT
 AME-**wa** hut-ta-ga ...
 rain-TOP fall-PAST-but
 ‘[It *rained*]_{CT} ... but (at least it wasn’t cold).’ (Satoshi Tomioka, p.c.)

Furthermore, contrastive *-wa* displays both of the distributional properties of CT discussed in section §2.4. First, *-wa* resists thoroughly exhaustive answers:

- (56) (Which boy left, Ken or Tamio?)
 #KEN-**wa** kaetta.
 Ken-TOP left
 ‘[*Ken*]_{CT} left...’ (Heycock 2008: 75)

Second, *-wa* resists maximal elements:

⁴⁵Another possibility for realizing sentential CT involves *-wa* marking a nominalized form of the verb, and the addition of a dummy verb to carry inflection:

- (i) Ame-ga HURI-**wa** si-ta-ga ...
 rain-NOM fall-TOP do-PAST-but
 ‘[It *rained*]_{CT} ... but (at least it wasn’t cold).’ (Satoshi Tomioka, p.c.)

- (57) a. MINNA-ga kita.
 all-NOM came
 ‘*Everyone* came.’
- b. *MINNA-wa kita.
 all-TOP came
 ‘[*Everyone*]_{CT} came...’ (Tomioka 2010b: 118–119)

As in English, the problem in (57b) can’t be chalked up to any general restriction against using CT on a quantificational expression. For example, (58) shows that contrastive *-wa* can mark a quantificational phrase, as long as it’s non-maximal:

- (58) (How many people will come to the party?)
- ZYUU-nin-wa kuru-desyoo.
 ten-CL-TOP come-EVID
 ‘(At least) [*ten* people]_{CT} will come... (as far as I can tell).’
 (Tomioka 2010b: 117)

Finally, as with English CT, we find that contrastive *-wa* can appear on maximal elements in downward entailing contexts. For example, in (59a), the *-wa*-marked quantifier *minna* ‘everyone’ scopes under negation. As (59b) shows, without *-wa*, only the opposite scope is possible, regardless of the intonation:

- (59) a. MINNA-wa ko-nak-atta.
 all-TOP come-NEG-PAST
 ‘Not [*everyone*]_{CT} came...’
- b. Minna-ga ko-nak-atta.
 all-NOM come-NEG-PAST
 ‘None of the people came.’ (Tomioka 2010a: ex. 4)

Overall a first look at Japanese contrastive *-wa* shows that this particle shares a great deal with English CT intonation, so it seems promising to account for the two phenomena under a single theory of CT meaning. At the same time, a general theory

of CT motivated by cross-linguistic considerations will have to make sense of certain differences between CT-marking strategies across languages. One salient difference concerns the appearance of CT in non-declaratives, which we turn to now.

2.6 CT in Non-Declaratives

Looking at CT marking in other languages exposes some general features of CT meaning that wouldn't have been apparent from looking at English alone. One important finding is that cross-linguistically, CT marking is possible in non-declarative speech acts, including questions and imperatives. The following CT question from Japanese illustrates:

- (60) ... zyaa ERIKA-**wa** doko-e itta-no?
then Erika-TOP where went-Q
'... well then where did [*Erika*]_{CT} go?' (Tomioka 2010a: 121)

In chapter §3 we'll take a closer look at CT questions, which are attested in Czech (Sturgeon 2006: 49), Japanese (Tomioka 2010a), Turkish (Kamali and Büring 2011) and Mandarin Chinese (Constant 2011, 2012b). In terms of their meaning, we'll see that—like CT declaratives—CT questions always appear in discourses containing a question that is addressed through a strategy of sub-questions. For example (60) naturally occurs in a discourse that has just finished addressing a contrasting sub-question “Where did Ken go?”.

The appearance of CT in questions is somewhat surprising from the perspective of English (and German, cf. Büring 2003: fn. 7), where questions don't typically display an overt CT contour. For example, despite occurring within a larger strategy, the final yes-no question in (61) bears a canonical rising L* H-H% contour, and the

context where the addressee has tests in multiple subjects and the speaker is aiming to resolve which of these subjects are worth studying for (Tomioka 2010a: 123).

- (63) EEGO-**wa** tyanto yatte-ok-e.
 English-TOP without.fail do-prepare-IMP
 ‘At least prepare yourself for [*English*]_{CT}...’ (Tomioka 2010a: 122)

While these cases haven’t been discussed in the literature to my knowledge, the English CT contour is also licensed in imperatives:

- (64) At LEAST study for [*ENGLISH*]_{CT}...
 H* L- L+H* L-H%

Overall, contrastive topic appears to be ubiquitous across a range of different speech act types. The ability to model this flexibility is thus an important design criterion for a theory of CT meaning.

Let’s wrap up this preliminary chapter. What have we done so far? In a nutshell, we’ve drawn out what looks like a fairly robust mapping in English (and a bit of Japanese) between CT realizations and CT meanings. That such a mapping exists in some form is relatively uncontroversial. What remains to be debated is (i) how to formalize the mapping, and (ii) what range of data the account should aim to cover. As a first step, we reviewed Büring’s (2003) theory of CT. One selling point of this model is its generality; a single mechanism handles CT+Exh, Exh+CT and lone CT, all in one fell swoop. In fact, we even pushed a little on its empirical boundaries and discovered that the model also makes reasonable predictions about both sentential CT and (to a first approximation at least) multiple CT examples.

So far so good. As we move into the next chapter, we’ll uncover some cases where this particular formalization runs into trouble. Our goal will be to respond to these technical challenges without sacrificing any of the generality of the account. In

the end, the proposal that I advocate will cover all of the examples that motivated Buring's proposal, while simultaneously addressing a series of new observations.

CHAPTER 3

THE TOPIC ABSTRACTION ACCOUNT

This chapter presents a new theory of the syntax and semantics of contrastive topic constructions—the TOPIC ABSTRACTION theory.¹ The account shares with Büring’s d-trees model the basic conception of CT as marking congruence to a discourse strategy. In fact, on simple examples, the predictions of the two theories as to what CT conveys and where it will be licensed are identical. However, the accounts differ significantly with respect to the logical form of CT examples, and the compositional semantics involved in interpreting them. Stemming from these structural differences are a number of points where the two models’ predictions diverge on more complex examples.

Section §3.1 presents a range of challenges for Büring’s d-trees theory. Some conceptual issues are discussed, but the main focus is on empirical problems relating to (i) CT in questions, (ii) island-sensitivity, (iii) multiple CT, and (iv) CT movement. Since no theory of CT to date has addressed all of these challenges, the thrust of this section is not that we should abandon Büring’s entire approach, but just that there are new empirical generalizations about CT that need to be captured. Section §3.2 presents the mechanics of the topic abstraction account, and offers a broad comparison between this and Büring’s model at the conceptual level. The following three sections show how the new account addresses the various empirical challenges: §3.3 treats CT questions, §3.4 explains the limited island sensitivity of CT, and §3.5 handles multiple

¹An earlier presentation of the topic abstraction account appears in Constant 2012b. This chapter presents the same basic analysis, but in a greater level of detail.

CT. The final two sections address remaining issues. Section §3.6 responds to specific criticisms of the idea that lone CT and Exh+CT can be successfully analyzed as sub-types of CT, and section §3.7 offers a brief comparison with two contemporary approaches: the models of Tomioka (2010b) and Wagner (2012).

3.1 Challenges for Büring 2003

This section presents a series of challenges for Büring’s (2003) model of CT. Some of these are purely conceptual issues. Other challenges arise at the syntax-phonology interface. Finally, we have a set of empirical issues relating to the circumstances under which CT can be used, and the meaning it will convey.

3.1.1 Formal Implementation

In section §2.3.3, we saw at an informal level how CT-values are calculated and how they constrain the surrounding discourse through CT-congruence. So that we can be perfectly clear about the predictions the model makes, it will be helpful at this point to refer directly to Büring’s formal definitions. These are given in (1) and (2).

(1) **CT-Value Composition** (Büring 2003: 539)

$$\begin{aligned}
 \llbracket A \rrbracket^{ct} = & \\
 \text{a.} & \quad \text{if } A \text{ is F-marked,} \quad \{ D_{\text{type}(A)} \} \\
 \text{b.} & \quad \text{otherwise, if } A \text{ is CT-marked,} \quad \{ \{ \alpha \} \mid \alpha \in D_{\text{type}(A)} \} \\
 \text{c.} & \quad \text{otherwise, if } A \text{ is a terminal,} \quad \{ \{ \llbracket A \rrbracket^o \} \} \\
 \text{d.} & \quad \text{otherwise, if } A = [B], \quad \llbracket B \rrbracket^{ct} \\
 \text{e.} & \quad \text{otherwise, if } A = [B C], \quad \{ \beta \mid \exists b, c [b \in \llbracket B \rrbracket^{ct} \ \& \ c \in \llbracket C \rrbracket^{ct} \\
 & \quad \quad \quad \& \ \beta = \{ \alpha \mid \exists b', c' [b' \in b \ \& \ c' \in c \\
 & \quad \quad \quad \& \ \alpha = b' + c']] \} \}
 \end{aligned}$$

(2) **CT-Congruence**

(Büring 2003: 520)

- a. Utterance U containing CT can map onto a move M within a discourse tree D only if U indicates a strategy around M_U in D .
- b. U indicates a strategy around M_U in D iff there is a non-singleton set Q' of questions such that for each $Q \in Q'$ —
 - (i) Q is identical to or a sister of the question that immediately dominates M_U , and
 - (ii) $\llbracket Q \rrbracket^o \in \llbracket U \rrbracket^{ct}$

Since Büring is adopting Roberts' discourse model, there are a number of additional constraints already at play restricting what a well-formed discourse structure can look like. However these constraints won't be directly relevant for the following discussion, so I refer the interested reader to Roberts (1996).

3.1.2 Conceptual and Interface Problems

At the conceptual level, the main cost of Büring's d-tree analysis is in the additional machinery it introduces, which appears to have no general utility outside of the domain of treating CT. First, a new dimension of meaning is posited, the CT-value. This necessitates the stipulation of a new set of composition rules, given in (1) above.² Compared to F-values, the meaning encoded by CT-values takes more work to specify formally, and corresponds less clearly to any basic notion. F-values are easy to understand at an intuitive level. They are just alternative sets produced by substituting different values for focused phrases. CT-values, on the other hand, are complex nested objects. They are sets of sets produced by substituting "first" for F-marked phrases, and "then" for CT-marked phrases.

²Beyond these, additional rules would be needed to specify the effect of various syncategorematic operators on the CT-value. These include, for example, predicate abstraction, Rooth's squiggle operator, the question operator (e.g. on a theory like Beck 2006), and so on.

Second, a CT-congruence condition is stipulated. This places an intricate set of requirements on utterances containing CT: that they are answers, that they answer a particular type of question, and that the answered question be a sub-question within a strategy whose other sub-questions have a particular shape. The condition captures key facts about how CT utterances are used in discourse. But ideally, these requirements would derive from some larger principle, so we wouldn't have to assert the details one by one.

If the problem were just that CT-values and CT-congruence are complicated bits of machinery, we might let it go. But the deeper issue is that these mechanisms seem to overlap to a large degree with existing mechanisms in terms of what they can accomplish. We will see shortly that (i) F-values can be used to store the kinds of meanings that Büring encodes in CT-values, and (ii) Rooth's squiggle operator can generalize to cover the type of anaphora marked by Büring's CT-congruence. Thus, the conceptual argument is not just a rally against complexity, but against redundancy as well.

Another general problem for the d-trees model and its predecessors lies in how they treat the realization of CT at the syntax-phonology interface. These theories all rely on some form of the mapping principle from section §2.2 to explain the English correlation between CT phrases and CT prosody. On Büring's version, each syntactic CT-mark is taken to map onto a CT contour $L+H^* L-H\%$. However the mechanism for controlling this mapping is pure stipulation, and violates the principle of modularity in grammar. On an ideal model, the interface between syntax and phonology would be tightly constrained, such that a syntactic feature could only affect the phonology through general interface principles. To let $[\cdot]_{CT}$ map directly to $L+H^* L-H\%$ is to sidestep this interface, whose nominal purpose is to predict features like accent shape, accent location and phrasing in general terms.

This complaint about the interface is rather abstract at this stage. In chapter §5, we will make the issue more concrete by considering specific proposals about the nature of the syntax-phonology interface. We will also address a number of empirical issues that arise at the interface. I preview just one of these challenges here. Given the mapping principle, it's not clear why CT markers like the English boundary tone L-H%, Japanese *-wa* or Mandarin *-ne* would ever appear at a distance from the CT phrase. However, such realizations are common. For example, in (3) and (4), the CT boundary L-H% is delayed beyond the right edge of the CT phrase.

- (3) (Did Persephone and Antonio bring vegetarian dishes?)

[PERSEPHONE]_{CT} brought one...
 L+H* L-H%

- (4) (What about MARY? Did SHE bring something tasty?)

The dish that [MARY]_{CT} brought ... was [SUPERB]_{Exh}.
 L+H* L-H% H* L-L%

3.1.3 CT Questions

We saw in section §2.6 that Japanese CT *-wa* can occur in questions. This feature turns out not to be peculiar to Japanese; a diverse set of languages displays CT-marking in questions. Furthermore, the basic meaning of CT—implying the existence of a multi-question strategy—appears to be preserved across all of these cases. This section presents a number of examples of CT questions, and shows how they pose a challenge for Büring's (2003) model of CT meaning.

First, let's take a look at the data. The Japanese example from chapter §2 is repeated in (5). This use of *-wa* is contrastive (attaching to a phrase bearing contrastive stress), and according to Tomioka (2010a: 123) marks the phrase to its left as a CT, just like contrastive *-wa* in declaratives. This interpretation is consistent with Tomioka's translation, which suggests a discourse addressing contrasting questions of the form "Where did *x* go?".

- (5) ... zyaa ERIKA-**wa** doko-e itta-no?
 then Erika-TOP where went-Q
 ‘... well then where did [*Erika*]_{CT} go?’ (Tomioka 2010a: 123)

In Czech, CT phrases appear in a fixed position in the left periphery (Sturgeon 2006). The operation by which phrases reach this position, which Sturgeon refers to as “contrastive topicalization”, is distinguishable from other kinds of topicalization by the prosody and case of the dislocated phrase. Contrastive topics receive rising prosody (p. 146) and display obligatory case matching (p. 56)—showing the same case as the clause-internal gap or resumptive. Example (6) illustrates. In the first clause, for instance, the phrase *svůj sešit* ‘my notebook’ has been contrastively topicalized, and receives a CT interpretation, setting up a contrast with the question about my textbook.

- (6) Svůj sešit jsem ztratil, ale svou učebnici ještě mám.
 self’s notebook.ACC AUX.1SG.CL lost but self’s textbook.ACC still have.1SG
 ‘[My *notebook*]_{CT} ... I [*lost*]_{Exh.} But [my *textbook*]_{CT} ... I [still *have*]_{Exh.}’

The same movement to CT position can occur in questions, as in (7) and (8). The choice to place the bolded phrases in the dedicated CT position has the same kind of effect as CT-marking in declaratives; it is implied that the discourse contains a strategy of contrasting questions that vary in the topic position. For instance, Sturgeon (2006: 153) observes that (7) would most likely be followed by a question of the type: “And your *gerbil*, who did you give *that* to?”³ Similarly, the naturally occurring (8) immediately follows a sentence “And Josef, he likes the idea”, suggesting

³I thank Radek Šimík (p.c.) for discussion of (7). In line with his judgments, I’ve adjusted Sturgeon’s translation and marked sentential stress. Radek also points out that (i) is a more natural choice in the contrastive context considered here:

- (i) A toho svého PSA? Komu jsi dala TOHO?
 and that self’s dog.ACC who.DAT AUX.2SG.CL gave that.ACC
 ‘And [*your dog*]_{CT}? Who did you give HIM to?’ (Radek Šimík, p.c.)

a discourse strategy addressing the issue of what different people think, one person at a time.

- (7) **Toho svého PSA,** komu TOHO jsi dala?
 that self's dog.ACC who.DAT that.ACC AUX.2SG.CL gave
 ‘[Your *dog*]_{CT}, who did you give him to?’ (Sturgeon 2006: 153)

- (8) A co **Ema** by na to řekla?
 and what Ema COND.3SG.CL on it say
 ‘And what would [*Ema*]_{CT} say about that?’
 (Sturgeon 2006: 49, from Lenertová 2001)

Mandarin Chinese has a CT marker *-ne* that occurs in a wide range of contexts, including questions. The claim that *-ne* conveys CT meaning is defended in detail in chapter §6. For the time being, a few observations will suffice. First, *-ne* appears in two positions: either directly following a topic phrase in the left periphery, or else sentence-finally. In its topic-marking use, *-ne* marks the CT in CT+Exh structures, as in (9). When the particle is declarative-final, as in (10), it often marks sentential CT of the kind discussed in section §2.2.

- (9) Māma měi-tiān wǎnshang hěn wǎn cái huí-jiā.
 mom every-day night very late only.then return-home
 BÀBA **ne**, gāncuì jiù bù huí-lái.
 dad CT simply just not return-come
 ‘Every day mom doesn’t come home until late.
 [*Dad*]_{CT} ... [doesn’t even come back at *all*]_{Exh}.’ (Shao 1989: 174)

- (10) A: His family is poor, so you'd do better not to interact with him.
 B: Tā jiā yǒu sān tóu niú **ne**.
 his family have three CL cow CT
 'His family has three *cows*]_{CT} ... (!)
 (Isn't that proof that they're not poor?) (Tsao 2000: 16)

In questions, *-ne* is typically sentence-final, and marks the presence of a CT phrase within the sentence.⁴ The particle often occurs at a distance from the CT phrase, and in this respect is unlike the Japanese CT particle *-wa*.⁵ For example, in (11) the CT phrase is clause-initial, while the CT particle *-ne* appears sentence-finally. As in the other languages we've looked at so far, the CT phrase receives a high level of stress, indicated here with SMALL CAPS. And as before, CT marking indicates a contrasting question about a different topic. In this case, the contrasting sub-question is given overtly in the preceding clause.

- (11) Nǐ dǒng le. TĀ dǒng-bù-dǒng **ne**?
 you understand ASP he understand-not-understand CT
 'You understand now. But does [*he*]_{CT} understand?' (Chao 1968: 802)

Finally, Kamali and Buring (2011) observe a contrast between CT and Exh in Turkish yes-no questions. When the question particle *-mI* appears adjacent to a contrastively stressed element and the utterance ends with falling intonation, as in (12), the marked constituent is interpreted exhaustively.⁶ In schematic terms, the meaning

⁴In the theoretical literature, question-final *-ne* is often treated as a clause-typing particle that marks a clause as a wh- question (Cheng 1991: 21, Li 1992: 139, Aoun and Li 1993: 210, and Cheng et al. 1996: 80). However there are a wealth of arguments against this view (see e.g. Lin 1984: 220–221, Shi 1997: 133–134, Gasde 2004: 315–318, and Li 2006: 13–15), leading most authors who treat *-ne* in any detail to reject the analysis. See section §6.6.4 for further discussion.

⁵We'll see in the following section (§3.1.4) that in a limited range of cases, CT *-wa* can also mark CT at a distance. However this ability is, to my knowledge, limited to cases where the CT phrase is island-internal.

⁶The question particle *-mI* obeys the typical pattern of Turkish vowel harmony, surfacing as one of *-mi*, *-mu*, *-mü* or *-mü*, depending on the frontness and roundness of the preceding vowel.

can be paraphrased as “Is x the unique answer?”. However when the same particle appears sentence-finally with rising prosody, as in (13), the stressed constituent is interpreted as a contrastive topic, implying contrasting questions about different topics. Schematically, the meaning of the CT question is “What about x ? Is x one of the (non-unique) answers?”.

- (12) ALI **mi** dün iskambil oynadı ↓ ?
 Ali Q yesterday cards played
 ‘Was it [*Ali*]_{Exh} who played cards yesterday?’ (Kamali and Büring 2011: 3)

- (13) ALI iskambil oynadı **mi** ↑ ?
 Ali cards played Q
 ‘Was [*Ali*]_{CT} one of the people who played cards?’
 (Kamali and Büring 2011: 6)

While the prosody of the yes-no question and position of the question particle aren’t general mechanisms for CT marking, the fact remains that there is a surface distinction between CT and Exh in questions, and we need a way to capture this fact. Furthermore, as Kamali and Büring (2011) point out, these data—and even more clearly, the data in Japanese, Czech and Mandarin—are a challenge for Büring’s (2003) theory of CT. Let’s see why. In fact, nothing prevents us from placing CT-marks in a question, or from calculating the CT-value of a question. However we run into a number of problems when plugging the resulting CT-value into the definition of CT-congruence.

Based on the examples above, CT questions have the effect of implying that the marked question contrasts with other questions, varying in the CT position. To reduce the observations to a single schematic case, a CT question like (14) should imply a discourse containing a strategy of questions of the form “What did x bring?”.

(14) (And) what did [FRED]_{CT} bring?

The CT-congruence condition, repeated below, is not equipped to capture this kind of congruence. Clause (15b.i) implies that a CT-marked utterance is never itself a member of the relevant set of the contrasting questions (i.e. the CT-value), but is rather *dominated by* a question within this set. Thus, as it stands, the congruence condition will require not that the CT-marked question itself contrast with other questions, but that some larger and possibly implicit dominating question does.

(15) **CT-Congruence** (Büring 2003: 520)

- a. Utterance U containing CT can map onto a move M within a discourse tree D only if U indicates a strategy around M_U in D.
- b. U indicates a strategy around M_U in D iff there is a non-singleton set Q' of questions such that for each $Q \in Q'$ —
 - (i) Q is identical to or a sister of the question that immediately dominates M_U , and
 - (ii) $\llbracket Q \rrbracket^o \in \llbracket U \rrbracket^{ct}$

Thus, the first step towards incorporating these data under Büring's model would be to modify part (b) of the CT-congruence condition along the lines of Kamali and Büring (2011) as follows, where changes are in bold:

(16) **Generalized CT-Congruence** (to be revised)

- a. [as above]
- b. U indicates a strategy around **assertion** M_U in D iff there is a non-singleton set Q' of questions such that for each $Q \in Q'$ —
 - (i) Q is identical to or a sister of the question that immediately dominates M_U , and
 - (ii) $\llbracket Q \rrbracket^o \in \llbracket U \rrbracket^{ct}$
- c. U indicates a strategy around **question** M_U in D iff there is a non-singleton set Q' of questions such that for each $Q \in Q'$ —

- (i) Q is identical to or a sister of \mathbf{M}_U , and
- (ii) $\llbracket Q \rrbracket^o \in \llbracket U \rrbracket^{ct}$

Although it is unsatisfying to have to split the definition into two sub-conditions, this modification could be seen as encoding the real asymmetry that CT-marked statements *answer* sub-questions within a strategy, whereas CT-marked questions *are* sub-questions within a strategy. However there is a larger problem that still remains.

Returning to the example “What did $[\text{Fred}]_{CT}$ bring?”, what will its CT-value be? To get the congruence condition to make the right predictions, we need the CT-value of the utterance to be the set of questions of the form “What did x bring?”—just the same CT-value as that of the declarative “[Fred] $_{CT}$ brought [the beans] $_F$ ”. More generally, we would like the CT-value of a question to be the same as the CT-value of its (CT-marked) answer.

Unfortunately, this equality of CT-values for questions and answers cannot arise on Büring’s account. The root of the problem can be found in the definition of CT-value composition from (1). A corollary of this definition, provable via induction, is that the CT-value of any utterance is a set of sets of whatever type the utterance denotes. Thus, once we accept the basic premise that Büring inherits from Hamblin (1973) that a question denotes a set of propositions, we guarantee that the CT-value of a question will be a set of sets of sets of propositions, or a set of sets of questions. So as long as a question and statement denote different types, their CT-values will also be different types.⁷

We can illustrate a particular instantiation of the problem under a simple Hamblin semantics for questions, where the (ordinary) denotation of a wh- word is a set of individuals (e.g. $\llbracket \text{what} \rrbracket^o = D_e$). On this implementation, we can assign the LF in (17a)

⁷Technically, it would be possible to get the right type of CT value, provided a non-compositional analysis of questions on which the F-value of a question is the same as its ordinary semantic value.

to the question “What did [Fred]_{CT} bring?”, and compute its semantic values as in (17b–d).⁸ The question denotes a set of propositions, its F-value is a set of questions, and its CT-value is a set of sets of questions. Crucially, the extra level of embedding in (17d) makes this CT-value incompatible with either Büring’s original congruence condition, or the modified version we formulated above. Either condition will require that the discourse contain questions whose denotations are members of (17d). But since these are not question denotations, the condition will be unsatisfiable.

- (17) a. [Fred]_{CT} brought what
- b. $\llbracket \cdot \rrbracket^o = \{ \text{Fred brought the beans, Fred brought the pasta, ...} \}$
- c. $\llbracket \cdot \rrbracket^f = \left\{ \begin{array}{l} \{ \text{Fred brought the beans, Fred brought the pasta, ...} \}, \\ \{ \text{Mary brought the beans, Mary brought the pasta, ...} \}, \\ \dots \end{array} \right\}$
- d. $\llbracket \cdot \rrbracket^{ct} = \left\{ \begin{array}{l} \{ \{ \text{Fred brought the beans, Fred brought the pasta, ...} \} \}, \\ \{ \{ \text{Mary brought the beans, Mary brought the pasta, ...} \} \}, \\ \dots \end{array} \right\}$

To summarize then, the account of CT meaning in Büring 2003 is not well-equipped to handle CT marking in questions. The essence of the problem is that CT-values are computed in terms of substitutions to the ordinary semantic value. Since questions already denote sets, their CT-values will contain an unwanted extra level of embedding, and will hence be unusable for the purposes of discourse congruence. This problem extends to the updated version of CT-congruence in (16), which is itself already a question-specific complication for the d-trees theory.

3.1.4 Island Sensitivity

By positing CT- and F- marks in the syntax, Büring’s theory is able to interpret CT and Exh phrases in situ, without the need to move them to any operator position at

⁸I am ignoring wh- movement for the sake of exposition.

LF. As it stands, this type of theory predicts that CT and Exh phrases should not display any sensitivity to islands. This prediction is not pointed out by Buring, and has not been widely investigated in the literature.⁹

In Japanese, Hara (2006: 66) observes island effects governing the distribution of the CT marker, contrastive *-wa*. For example, contrastive *-wa* can't attach directly to a CT phrase within the adjunct island in (18a), or the complex NP island in (18b). I've marked the relevant island structure in each example with bracketing.

(18) **CT *-wa* in Island**

- a. *Itsumo [uchi-ni JOHN-**wa** kita toki], inu-ga hoe-ru.
always house-to John-TOP come when, dog-NOM bark-NONPAST
'[Whenever [*John*]_{CT} comes over] the dog barks...'
- b. *Itsumo [CHOMSKY-**wa** kai-ta hon]-ga shuppan sa-re-ru.
always Chomsky-TOP write-PAST book-NOM publish do-PASS-NONPAST
'[The books that [*Chomsky*]_{CT} writes] are always published...'

(Hara 2006: 66)

As Hara (2006: 73) points out, it is possible to have CT phrases island-internally, but in these cases the CT particle *-wa* attaches to the edge of the island structure, rather than directly to the CT. Thus, the grammatical counterparts of the island violations above are as follows:¹⁰

⁹Tomioka (2010a: fn.7) presents some arguments in favor of the in-situ approach, but doesn't mention the island effects. Hara (2006: 66) points out island effects, and aims to account for them via movement, but not of the CT phrase itself.

¹⁰It isn't clear from Hara's discussion whether these sentences are to be interpreted as lone CT or CT+Exh. I've given lone CT translations, on the assumptions that (i) no phrase apart from the CT bears sentential-level stress, and that (ii) an Exh element would have to bear sentence-level stress. For reference, Hara's original translations are "At least when John comes to our house, the dog always barks" and "At least the book which Chomsky wrote is always published."

(21) **CT in Island, Exh outside Island**

- a. (How would Fred or Sue be as a partner for Mary?)

[FRED]_{CT} and Mary ... would be [GOOD]_{Exh} partners.
L+H* L-H% H* L-L%

- b. (How were the drawings that Fred and Sue did of Mary?)

The drawing [FRED]_{CT} did of Mary ... was [SPECTACULAR]_{Exh}.
L+H* L-H% H* L-L%

Even in the above examples, there is some evidence of island sensitivity. One component of the CT contour—the L-H% boundary tone—mirrors Japanese *-wa* in occurring at a distance from the CT phrase, at the island boundary. And parallel to the Japanese cases, it's impossible for this marker of CT to occur any closer, as (22) shows. Since Büring's theory directly associates the entire CT contour (L+H* L-H%) with CT marks, it predicts incorrectly that the L-H% boundary will line up with the edge of the CT-marked phrase. Perhaps one could appeal to independent prosodic constraints to block the L-H% placement in (22), but then it isn't clear how the principle mapping CT-marks to L+H* L-H% interfaces or competes with such constraints.

(22) **CT Boundary in Island**

- a. (How would Fred or Sue be as a partner for Mary?)

??[FRED]_{CT} ... and Mary would be [GOOD]_{Exh} partners.
L+H* L-H% H* L-L%

- b. (How were the drawings that Fred and Sue did of Mary?)

??The drawing [FRED]_{CT} ... did of Mary was [SPECTACULAR]_{Exh}.
L+H* L-H% H* L-L%

We see further evidence for island sensitivity in the fact that CT and Exh can never co-occupy the same island. The CT+Exh examples in (23) illustrate. Furthermore, paraphrases with the same information structure are acceptable, provided that the Exh phrase is island-external, as in (24).

(23) **Both CT and Exh in Island**

- a. (What about Fred and Sue? Who should we pair each of *them* with?)

?? [FRED]_{CT} ... and [MARY]_{Exh} would be good partners.
L+H* L-H% H* L-L%

- b. (What about Fred and Sue? Which of *their* drawings were the best?)

?? The drawing [FRED]_{CT} ... did of [MARY]_{Exh} was the best.
L+H* L-H% H* L-L%

(24) a. (What about Fred and Sue? Who should we pair each of *them* with?)

[FRED]_{CT} ... would be a good partner for [MARY]_{Exh}.
L+H* L-H% H* L-L%

- b. (What about Fred and Sue? Which of *their* drawings were the best?)

The best drawing [FRED]_{CT} did ... was the one of [MARY]_{Exh}.
L+H* L-H% H* L-L%

Again, these data are surprising for an in-situ theory of CT interpretation, where the only constraints on what can be CT- and Exh-marked concern the meaning produced. Furthermore, with (23), we don't have the option of simply "adjusting" the contour using independent constraints as we considered for (22). Regardless of where the pieces of the CT and Exh contours fall, there is just no way to realize a CT and an Exh phrase together in an island. Yet in the eyes of the d-trees theory, there is no reason this configuration should be ruled out.

3.1.5 Multiple CT

Sentences with multiple CT constitute another challenge for Büring's theory. In this section, I present preliminary evidence suggesting that one CT phrase can "out-scope" another, and that the felicity in discourse of sentences with multiple CTs can depend on which CT is structurally higher. These findings run counter to the predictions of Büring 2003, as well as more recent theories including Tomioka 2010b.

The problematic data that I'd like to present involve a new diet I've been trying. It's called the ABC diet, and works like this:

(25) **The ABC Diet**

Every day, eat the following three meals, in any order you like:

- A. one avocado
- B. one burrito
- C. one cheesecake

To avoid monotony, I've been varying the order of the three meals according to the day of the week. For instance, Sunday is a "CBA" day: (C)heesecake for breakfast, (B)urrito for lunch, and (A)vocado for dinner. When I told my friend Ann about the diet, she was curious to hear how I'd organized my weekly menu. She made the following request, and I started to respond, as follows:

(26) A: For each day of the week, tell me what time you have each food.

B: On [SUNDAYS]_{CT} ... [the BURRITO]_{CT} ... I have for [LUNCH]_{Exh}.
 L+H* L-H% L+H* L-H% H* L-L%

If Ann had formulated her request differently, my response might have started differently. For instance:

(27) A: For each food, tell me what time you have it on each day.

B: [The BURRITO]_{CT} ... on [SUNDAYS]_{CT} ... I have for [LUNCH]_{Exh}.
 L+H* L-H% L+H* L-H% H* L-L%

Interestingly, while (26) and (27) constitute natural request-response pairs, the reverse pairings are somewhat degraded:

(28) A: For each day of the week, tell me what time you have each food.

B: ?[The BURRITO]_{CT} ... on [SUNDAYS]_{CT} ... I have for [LUNCH]_{Exh.}
 L+H* L-H% L+H* L-H% H* L-L%

(29) A: For each food, tell me what time you have it on each day.

B: ?On [SUNDAYS]_{CT} ... [the BURRITO]_{CT} ... I have for [LUNCH]_{Exh.}
 L+H* L-H% L+H* L-H% H* L-L%

These judgments are a first indication that multiple CT sentences can mark congruence to richly structured strategies. For example, my response in (26) seems to imply a broad strategy of questions about different days, each of which is itself a strategy broken into sub-questions about when I eat different foods on that day. A discourse tree proceeding along these lines is given in (30). I will refer to this discourse as sorting “days over foods”, reflecting the fact that the issues about days are made up of smaller issues about foods, and not the other way around. I will also refer to the over-arching strategy in (30) as DOUBLY-NESTED, since it contains not only questions and sub-questions, but also sub-sub-questions.

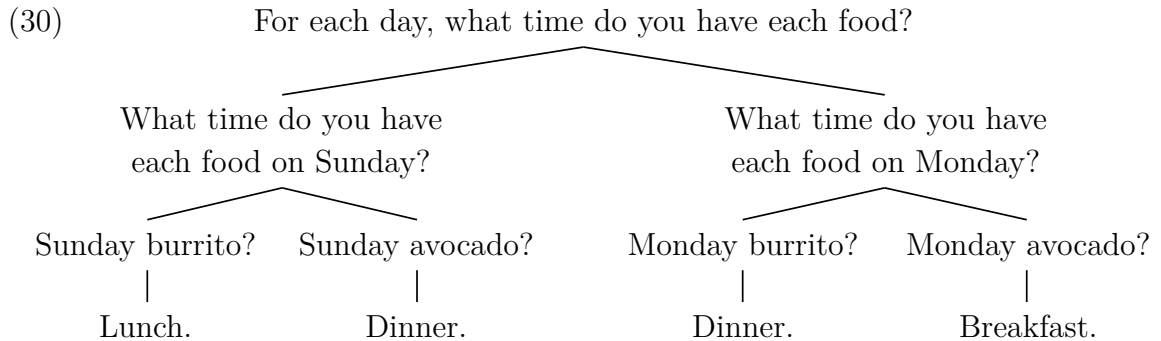

The decision to sort first and foremost by days (over foods) has consequences for how the discourse is expected to progress. The implication is that we will finish with any Sunday-related issues before moving on to Monday. From a cognitive perspective, the “cost” of sorting by days is that we’ll address some burrito-related issues now, and then move on to other foods, only to come back to burritos later. However this “scattering” is unavoidable (assuming that each possible food-day pair is at issue). If

we had sorted by foods over days, as in (27), the burrito issues would cluster together, but the Sunday issues would become scattered.

If the sentences in (26) and (27) do indeed impose congruence to doubly-nested strategies of the kind shown in (30), this should be detectable in the felicity of continuations that respect or violate the implied discourse structure. The following data provide striking support for this view:

(31) On [SUNDAYS]_{CT} ... [the BURRITO]_{CT} ... I have for [LUNCH]_{Exh.}
 L+H* L-H% L+H* L-H% H* L-L%

- a. And the AVOCADO ... I have for DINNER.
- b. ??And on MONDAYS ... I have (it) for DINNER.

(32) [The BURRITO]_{CT} ... on [SUNDAYS]_{CT} ... I have for [LUNCH]_{Exh.}
 L+H* L-H% L+H* L-H% H* L-L%

- a. And on MONDAYS ... I have for DINNER.
- b. ??And the AVOCADO ... I have for DINNER.

Taken together, these facts indicate the need for a theory that can—in some circumstances at least—distinguish two CT phrases in terms of which is sorted “higher” in the discourse structure. However this nesting of strategies within strategies can’t be modeled using Büring’s CT-values, since there is only a binary distinction between CT- and F- marks. The composition rules for CT-values ensure that regardless of syntactic position, all CT-marked phrases end up collapsed to a single level in the discourse structure. Thus, for example, (26) and (27) receive the same CT-value, and we fail to account for the asymmetry between the two forms:¹²

¹²I’m ignoring the movement and binding structures that are no doubt present in the LFs for these sentences. However adding this extra structure won’t have any effect on the resulting CT-value.

$$\begin{aligned}
(33) \quad & \llbracket \text{on [Sundays]}_{\text{CT}} \text{ [the burrito]}_{\text{CT}} \text{ I have for [lunch]}_{\text{F}} \rrbracket^{ct} \\
& = \llbracket \text{[the burrito]}_{\text{CT}} \text{ on [Sundays]}_{\text{CT}} \text{ I have for [lunch]}_{\text{F}} \rrbracket^{ct} \\
& = \left\{ \begin{array}{l} \{ \text{Sunday burrito is lunch, Sunday burrito is dinner, ...} \}, \\ \{ \text{Monday avocado is lunch, Monday avocado is dinner, ...} \}, \\ \dots \end{array} \right\} \\
& = \text{For each food-day pair, when do you have that food on that day?}
\end{aligned}$$

As with CT questions, the problem here is an inflexibility in how CT-values are composed. No matter how many F- and CT- phrases are present, the CT-value of a declarative will only go two levels deep; it will be a set of sets of propositions—i.e. a set of simple questions.

Given the structure of Büring’s account, the natural way to add another layer of nesting would be to repeat the process of introducing CT-marks all over again. We would have CT_1 and CT_2 marks in the syntax, and CT_1 - and CT_2 - values in the semantics. The composition rules for $\llbracket \cdot \rrbracket^{ct_2}$ would be hairier than those in place for $\llbracket \cdot \rrbracket^{ct_1}$, but would get the job done. But all of this begs the question of whether there isn’t a more general solution that can add successive layers of embedding for each CT. The topic abstraction account in §3.2 aims for a solution of this kind.

If the problem for Büring’s model were just the fact that we have to stipulate “higher-order” CT-marks, we could imagine a response that implemented arbitrarily many levels of CT-marking (CT_1 – CT_n), whose interpretation could be specified through a general schema. However while this would no doubt be technically possible, it still wouldn’t address the empirical issue raised by the examples discussed above.¹³ To capture the asymmetry between the structurally higher and lower CT in these examples, we would need to add extra syntactic conditions on the distribution of the different levels of CT-marks. This is both an extra complication, and runs counter to a basic premise of the in-situ account—that CT- and F- marks are freely distributed.

¹³I thank Chris Potts for bringing this point to my attention.

As the licensing of multiple CT has not been explored in the literature to my knowledge, and the judgments are somewhat subtle, the facts should be investigated more carefully, and across a range of languages. I leave this to future work, but point out a few relevant places to look. First, Yabushita (2008) has documented sentences of Japanese with multiple CTs, as in (34).¹⁴ However, he does not address the discourse licensing of such sentences, and indeed Yabushita’s formal account will not allow one CT to scope above another. It may turn out that examples like (34)—where multiple CTs can be analyzed as all being *in situ*—are generally ambiguous as to the scopal relation between the CT elements. If so, these sentences will not provide direct evidence for congruence to doubly-nested strategies.

- (34) Jon-**wa** Mearii-**wa** Biru-ni-**wa** shookai-shi-ta.
 John-TOP Mary-TOP Bill-to-TOP introduction-do-PAST
 ‘[John]_{CT} introduced [Mary]_{CT} to [Bill]_{CT}.’ (Yabushita 2008: 748)

Slightly more promising parallels are found in German and Korean. Krifka (1998) presents the German CT+CT+Exh example in (35), and reports that “the topics are not ranked equally; rather, one topic has ‘scope’ over the other.”¹⁵ Similarly, Lee (2003) discusses the Korean example in (36) as having three CTs, and notes (fn. 4) the intuition that the sentence-initial CT “takes scope” over the other two.¹⁶ However while these intuitions are suggestive, it remains to be demonstrated (i) what

¹⁴I have reproduced Yabushita’s translation verbatim, including the CT-marking within it. However, in the absence of a context or stress marking, it is not clear to me that this analysis is motivated, as opposed to treating at least one of the *-wa*-marked phrases as a non-contrastive (i.e. “thematic”) topic. General consensus is that non-contrastive *-wa* is limited to one per sentence, following Kuno (1973: 48), so this would still imply at least two CTs in (34).

¹⁵Krifka’s acute accents (´) represent rising pitch accents, while the grave accent (`) represents a falling pitch accent. Krifka doesn’t mention *which* topic has scope over the other, although the context suggests that the higher topic in surface syntax gets higher discourse scope, as in the other examples we’ve seen.

¹⁶The CT-marking in the translation of (36) is based on Lee’s description of the alternatives evoked by each phrase. Presumably the location of stress (which wasn’t indicated in the original example) disambiguates towards the desired interpretation.

the consequences of this intuitive asymmetry are on question-answer congruence and possible continuations, and (ii) what the implication is between syntactic position and relative scope of multiple CTs in German and Korean.

(35) A: What about Peter and Pia? Did they get any gifts from Mary or Sue?

B: PÍA hat von MÁRY einen BÀLL geschenkt bekommen.

Pia has from Mary a ball given get

‘[*Pia*]_{CT} ... received from [*Mary*]_{CT} ... [a *ball*]_{Exh.}’ (Krifka 1998: ex. 19)

(36) I ai-**nun** tongsayng-hanthe-**nun** inhyeng-**un** cu-ess-ta.

this child-CT brother-DAT-CT doll-CT give-PAST-DECL

‘[*This*]_{CT} child gave [the *doll*]_{CT} to his [*younger*]_{CT} brother...’

(Lee 2003: ex. 39)

One final parallel to the English facts is found in Dholuo, a Nilo-Saharan language of Kenya and Tanzania. The Dholuo CT particle *-to* occurs exclusively marking fronted contrastive topics, and may occur more than once per clause (Constant 2009). In the following example, the surface order of two CTs reflects their relative scope in a discourse that sorts people over vegetables—as evidenced by the fact that we stick to a single person across different vegetables.^{17,18} The d-tree in (37) illustrates the discourse structure hypothesized to be implied by the CT-marking.

¹⁷The Dholuo data reported here come from my elicitation work with Martina Achieng’ within the context of Seth Cable’s 2009 UMass Amherst field methods course. I am grateful to Martina for patiently sharing her insights about her language, as well as to Seth for his help in organizing and contributing to the elicitation process. I also thank consultant Milton Joshua Obote and the participants of the course for additional help.

¹⁸I’m not transcribing tone, ATR contrasts, or vowel length, each of which have phonemic status in the language, as discussed by Tucker (1994).

facts on a wider range of examples, including negative data. A deeper investigation of multiple CT sentences cross-linguistically is an important project for future research.

3.1.6 CT Position

One final issue for Büring’s theory derives from the fact that it draws no connection between CT-hood and syntactic position. We already saw one consequence of this blindness to syntax in the previous section: the model has no way of distinguishing the relative scope of two CTs based on their syntactic position. Another consequence is the inability to explain the existence of dedicated syntactic positions that appear to be available only to CT phrases.

In English, TOPICALIZATION refers to the movement of a (non-wh-) argument to a position leftward of the subject, leaving a gap below. As (40) shows, topicalization is often readily available to CT phrases.

(40) A: What about the beans and the salad?

Who brought *those*?

B: [The BEANS]_{CT} ... [FRED]_{Exh} brought.
 L+H* L-H% H* L-L%

By contrast, topicalization is typically unavailable to Exh phrases:²⁰

²⁰Prince (1999: §3.1) discusses a “focus movement” structure where an exhaustive focus surfaces before the subject, as in (i). However she also notes that the construction is “extremely highly constrained”, and has a distinct prosody (compared to topicalization), with main stress on the initial focus, and no sentence-level stress following.

(i) She was here two years. <checking transcript> FIVE semesters she was here.

- (41) A: What did Fred bring?
B: #[The BEANS]_{Exh}, Fred brought.

Cross-linguistically, English is not alone in having particular syntactic configurations that are available to CTs but not Exh phrases. Even in languages where exhaustive foci can also raise to the left periphery, it is commonly observed that CTs raise to a *higher* position. For example, this is claimed to be the case for Italian (Benincà and Poletto 2004, Frascarelli and Hinterhölzl 2007) and Hungarian (É. Kiss 2007, Gyuris 2012).

Of course, with a dedicated syntactic feature marking every CT constituent, there is nothing in Büring’s theory to stop us from formalizing a CT operator in the left periphery that attracts CT phrases. However, there’s equally nothing stopping us from *not* positing this operator. Thus, at best, the account stipulates that CTs can raise to a particular position, and fails to *explain* this fact.

3.2 The Topic Abstraction Account

In the previous section, we looked at some challenges for Büring’s (2003) theory. First, the account doesn’t yet give a clear picture of how CT is realized prosodically—specifically, how the different pieces of the CT contour are distributed over the sentence. Second, the account is challenged by CT questions, island sensitivity, and multiple CT data. Finally, the theory draws no connection between CT meaning and the left-peripheral position that CTs commonly occupy cross-linguistically.

In this section, I present an account that addresses these challenges—the “topic abstraction” account. The account builds on recent work by Kadmon (2009), Tomioka (2010a, 2010b), Davis (2010) and Wagner (2012). In particular, I adopt the latter three authors’ contention that, contra Büring, contrastive topics don’t need to be given a privileged status as a new, *other* kind of focus (in the sense of F-marking). Rather, CTs are just F-marked phrases in a specific configuration. I will refer to

such theories as CONFIGURATIONAL theories of CT. On a configurational theory, what distinguishes a CT from any other focused elements (e.g. Exh) is not the syntactic feature it bears, but the way its focus alternatives are used in the semantic computation. For instance, a CT phrase may be defined as a F-marked phrase in a particular structural position, or bound by a particular focus-sensitive operator. After presenting the topic abstraction account and its treatment of some of the above challenges, I will make some brief comparisons with other configurational theories in section §3.7. The issue of how configurational theories of CT interface with the phonological system is addressed in chapter §5.

3.2.1 Question-Answer Congruence

The basic idea I'd like to pursue is that CT congruence is just one special case of focus anaphora to a contextual question. We'll start by reviewing how focus anaphora works in Rooth's (1985, 1992, 1996) alternative semantics, concentrating on the case of question-answer congruence.

Rooth's treatment of question-answer congruence is a formalization of the insight from Jackendoff (1972: §6) that a particular pattern of focus marking has the effect of presupposing that an issue of a particular shape is under discussion in the discourse.²¹ As we've already seen, every expression is taken to have a focus value $[[\cdot]]^f$, which is the set of alternatives attainable by making substitutions in F-marked positions. Rooth defines the presupposition introduced by focus using a special operator, the squiggle (\sim) operator, roughly as follows:²²

²¹This is a rather loose interpretation of Jackendoff's specific proposal. For the formal details, which differ in a number of important ways from Rooth's implementation, see Jackendoff (1972: §6.4).

²²Rooth actually defines squiggle as a two-place operator. In addition to the ϕ argument shown in (42), the official squiggle also combines with a silent syntactic variable Γ that is presupposed to have an antecedent C with the properties listed in (42c). I've opted for the simplified version since it's not clear to me that representing the focus anaphor in the syntax gains us any more than the notational convenience of being able to identify its antecedent via coindexation. Furthermore, the two-place version would seem to require an extra stipulation that the Γ argument be silent.

(42) **Squiggle Operator**

(cf. Rooth 1996: 279)

- a. $[[\sim \phi]]^o = [[\phi]]^o$
- b. $[[\sim \phi]]^f = \{[[\phi]]^o\}$
- c. ... and presupposes that the context contain an antecedent C such that:
 - i. $C \subseteq [[\phi]]^f$
 - ii. $|C| > 1$
 - iii. $[[\phi]]^o \in C$

Clauses (a) and (b) define the output of the squiggle operator in the ordinary and focus dimensions. Their effect is that squiggle passes on the ordinary value of its complement unchanged, but resets the focus value—having used this value to build the presupposition in (c).²³ In the cases that we will be concerned with, the squiggle receives widest scope, so the values it passes as output won't be relevant.

Squiggle's real work is done by clause (c), which introduces the presupposition of a contextual antecedent whose meaning is a subset of the F-value of squiggle's complement. In the same way that a referential pronoun refers back to a salient individual, we can think of an occurrence of focus as anaphoric to the contextual antecedent required by the squiggle binding that focus. Thus, we can describe the presupposition of squiggle as encoding "focus anaphora".

In the case of a wide-scoped squiggle attaching to a declarative, this presupposition demands an antecedent denoting a set of propositions—in other words, a question. Furthermore, the potential answers to this question antecedent must all be members of the alternative set produced by substituting for the F-marked phrases in the original declarative. To take an explicit example, consider the statement in (43a) and the corresponding LF in (43b). The focus value of squiggle's complement is shown in

²³I may refer to squiggle's sister in the phrase structure as its "complement" or "argument". However these terms should be taken loosely, since squiggle doesn't compose via function application, and its syntax presumably falls outside of the standard head-complement-specifier schema.

(43c). Thus, we predict that this utterance will presuppose an antecedent question made up of at least two alternatives of the form “ x wants coffee”, one of which is the alternative “Ede wants coffee”.

- (43) a. EDE wants coffee.
 H* L-L%
- b. \sim [[Ede]_F wants coffee]
- c. [[[Ede]_F wants coffee]]^f
 = { Ann wants coffee, Bob wants coffee, ... }
 = Who wants coffee?

This account correctly predicts the viability of (43) as a response to a wh- question “Who wants coffee?”. Questions deciding among fewer alternatives are an option as well—for example, the statement could answer the alternative question “Does Ede or Fred want coffee?”. At the same time, we capture the incongruence of (43) as an answer to questions like “What does Ede want?” or “Does Ede want coffee?”.²⁴ While these questions each contain the proposition *Ede wants coffee* as one potential answer, their other potential answers don’t fit the mold presupposed by the focus marking; that is, they don’t have the form “ x wants coffee”.

Before we move on, one final note about Rooth’s squiggle is in order. In the “strong version” of alternative semantics, Rooth (1992: 95) proposes that squiggle is the only operator that has access to focus values. This amounts to saying that the uniform effect of focus is just to mark anaphora to discourse antecedents that denote

²⁴Deriving this incongruence actually requires an extra step. All that squiggle enforces is the existence of some contextual antecedent of the right form. There is no explicit condition placed on this antecedent being an overt or recent object of discussion. Thus, nothing would prevent (43) from standing as a direct answer to an incongruent question, provided that a congruent question was also salient in the context. I take this to be a general issue for the theory of anaphora, not limited to focus anaphora. For instance, when I say “John walked into the room. He sat down,” you will most likely understand me as meaning that *John* sat down, even if other male individuals are technically available as potential antecedents for the pronoun.

alternative sets.²⁵ On this refined view of what focus can and can't do, focus-sensitive operators like *even* and *only* are defined as operating over free variables, which are in turn restricted by squiggle as to their reference.²⁶

3.2.2 Nested Focus Values and Sorted Questions

How should we begin to reformulate Büring's CT-congruence condition in a theory with no CT-marking or CT-values? I repeat the informal notion of CT-congruence in (44). At its core, Büring's CT-congruence has an effect much like Rooth's squiggle. In fact, we can draw out the similarity by stating the effect of squiggle in question-answer paradigms as in (45).²⁷ Both conditions look for a discourse antecedent whose denotation contains at least two alternatives, and whose structure is related in a particular way to the marked utterance.

²⁵On the implementation of Rooth 1992, a formal distinction is made between anaphora to *single* contrasting individuals and to *sets* of contrasting individuals. The individual case allows, for example, a sentence like "No, MARY won!" to have as its focus antecedent a preceding sentence like "John won." However, I assume that in any such discourse, the corresponding constituent question (e.g. "Who won?") will be available as a potentially implicit antecedent, so the bifurcation into the individual and set case is unneeded. The formulation of Rooth 1996 does away with the individual case, so squiggle always marks anaphora to a set, although the motivation for this reduction is not discussed.

²⁶This is achieved by coindexing the free variable argument of the focus-sensitive operator (e.g. *only*) with the silent syntactic variable argument of squiggle discussed in footnote 22. Since nothing seems to enforce the correct coindexing, I prefer to maintain the one-place squiggle in (42) and leave it to the pragmatics to equate the two variables.

²⁷This question-answer congruence condition is not directly enforced by Rooth's system, since it is just a special case of the more general anaphora marked by squiggle. In the general case, the type of antecedent presupposed will depend on the scope of the squiggle, and need not be a question.

(44) **CT-Congruence** (informal, cf. Büring 2003: 520)

An utterance U with CT-marking answers a question within a strategy containing ≥ 2 questions from the set $\llbracket U \rrbracket^{ct}$.

(45) **Question-Answer Congruence** (informal, cf. Rooth 1996: 279)

An utterance U with F-marking answers a question containing ≥ 2 alternatives from the set $\llbracket U \rrbracket^f$.

This parallelism suggests that CT-congruence may be derivable as a special case of the congruence enforced by Rooth’s squiggle. Let’s see how this might work. Suppose that by some as-of-yet unspecified means, we get the F-value of an utterance to be a set of questions—exactly the same type of semantic object stored in Büring’s CT-values. What would the squiggle operator predict in terms of the discourse?

To take a specific example, consider our familiar CT+Exh utterance in (46). Ignoring for the time being the details of logical form and semantic composition, let’s assume that this utterance has the F-value shown in (46)—the same as the utterance’s CT-value on Büring’s model. Unlike typical focus values, this F-value has the property of being NESTED—it contains sets as members.

(46) $\llbracket \text{“}[\text{Fred}]_{CT} \text{ brought } [\text{the beans}]_{Exh} \text{”} \rrbracket^f$
 $\stackrel{?}{=} \{ \text{What did Fred bring? What did Mary bring? ...} \}$
 $= \text{For each person, what did they bring?}$

If we attach a squiggle to the top of this as-of-yet unspecified logical form, the results are promising, but also somewhat puzzling. Based on (42c.i,ii), we derive a presupposition of an antecedent C whose meaning is a set containing at least two members of the F-value in (46).²⁸ Since the members of the F-value are questions, the antecedent C would have to be a denotation containing multiple questions. This brings us to a

²⁸I’m ignoring the conflicting clause (42c.iii) for the time being. We’ll return to this issue shortly.

fundamental problem. What type of semantic object is a set of questions? And what would it mean to refer anaphorically to such an object?

Following Hagstrom (1998) and Kadmon (2009), just as a set of propositions represents a question, we can understand a set of questions as a single complex question or discourse strategy.²⁹ For example, the focus value in (46) would represent the complex question “For each person, what did they bring?”. Notice that this complex question simultaneously represents an informational need (to establish who brought what) and an organizational decision to pursue the issue person by person, rather than thing by thing. The organizational component of the complex question corresponds to a choice of what Kuno (1982) refers to as the “sortal key”—indicating the decision to “sort by people”. With this in mind, I will refer to complex questions like the one in (46) as SORTED QUESTIONS.

Positing a sorted question meaning as an antecedent for focus anaphora does not necessarily commit us to the view that any linguistic form is denoting, or even could denote a sorted question. However going this extra step is quite natural, and would be in line with the view that multiple *wh*- questions can have sorted meanings (Hagstrom 1998), so that the expression “Who brought what?” could denote, among other things, the sorted question meaning shown in (46).^{30,31} Similarly, both Hagstrom (1998) and

²⁹I refer loosely to a complex question as representing a discourse strategy, since it implies both an overarching question (e.g. Who brought what?) as well as specific sub-questions (e.g. What did Fred bring?). However technically, in Roberts’ framework, a strategy also contains the answers to the sub-questions, which are not yet implied by the complex question. The loose usage of the term “discourse strategy” will persist through the rest of the dissertation. See page 93 for further discussion of what role (if any) discourse strategies play in the formalism.

³⁰We’ll look at this possibility in more detail in section §3.3.

³¹It’s common to refer to sorted readings of multiple *wh*- questions as “pair-list” readings (using the terminology of Engdahl 1980 and Groenendijk and Stokhof 1984), implying that the answer is a list of pairs rather than a single pair. But importantly, the opposition between sorted and non-sorted questions is not reducible to the pair-list vs. single-pair distinction. In particular, while sorted questions are pair-list, pair-list questions are not necessarily sorted. For example, just as a single *wh*- question “Who wants coffee?” can elicit a list of answers “Fred, Mary and Sue”, a multiple question “Who is married to who?” can simply be asking for a list of pairs, without imposing any sortal distinction between the *wh*- phrases. By contrast, a sorted question asks for a list of pairs

Kadmon (2009) suggest sorted question denotations for quantified questions like “For each person, what did they bring?”.³² Indeed, we have already been using quantified question paraphrases as shorthands for sorted question meanings throughout.

So far all we’ve done is promote a particular understanding of nested alternative sets—as representing sorted questions. With this understanding, we can interpret the effect of squiggle when attached to an utterance with a nested focus value. Returning to (46), the prediction (ignoring one minor glitch to be discussed below) is that this CT+Exh utterance presupposes a sorted question “For each person, what did they bring?” made up of at least two sub-questions “What did x bring?”. This is remarkably similar to the effect of Büring’s CT-congruence condition. The only difference is that CT-congruence stipulates that the CT utterance itself must directly answer a particular sub-question in a strategy, whereas the present account merely requires that the strategy of questions as a whole be salient. Since I do not see any way of distinguishing between these two positions empirically, it seems preferable to adopt the simpler approach, which follows Rooth in treating all question-answer congruence in terms of presupposing a question anaphor, without stating directly where that question is answered.

One minor glitch arises when we consider the effect of clause (42c.iii) in the definition of the squiggle operator. Limiting our attention to cases where squiggle attaches to a whole utterance (as we have been throughout), the condition $[[\phi]]^o \in C$ requires that the ordinary value of the utterance be one of the members of the presupposed

and imposes a sortal key. For example, one sorted interpretation of “What did you buy where?” is equivalent to “For each place, what did you buy there?”, while a separate sorted interpretation is “For each thing, where did you buy it?”. In general, English multiple *wh*- questions appear to be multiply ambiguous between different sorted interpretations, as well as at least one non-sorted interpretation (although see Dayal 1996 for a claim to the contrary). Section §3.3 provides further discussion.

³²Krifka (2001) doesn’t use sorted question denotations, but instead treats quantified questions as denoting a conjunction of speech acts. This approach shares the view that these question acts are at some level “made up” of multiple sub-questions. However, Krifka’s formalism doesn’t give us a way of referring to the sorted question as a simple semantic object in its own right.

alternative set C. In standard cases of question-answer congruence, this ensures, for example that “EDE is the tallest” will only be congruent to questions where “Ede” is a possible answer, ruling out congruence to question like “Which girl is the tallest?” (assuming Ede is not a girl).

However when we turn to nested focus values, this condition becomes impossible to fulfill. Consider our familiar CT+Exh example “[Fred]_{CT} brought [the beans]_{Exh}”. Its ordinary semantic value is just the proposition that Fred brought the beans, as in (47a). Its focus semantic value, by hypothesis, is the set of questions written out explicitly in (47b). Taken together, the conditions in (42c) demand an antecedent C that is both a subset of (47b), and contains (47a) as a member. In other words, C’s members must all be sets of propositions, but one member must be a proposition. Such a set does not exist.

- (47) a. $\llbracket \text{“[Fred]_{CT} brought [the beans]_{Exh}”} \rrbracket^o$
 = Fred brought the beans.
- b. $\llbracket \text{“[Fred]_{CT} brought [the beans]_{Exh}”} \rrbracket^f$
 $\stackrel{?}{=} \left\{ \begin{array}{l} \{ \text{Fred brought the beans, Fred brought the pasta, ...} \}, \\ \{ \text{Mary brought the beans, Mary brought the pasta, ...} \}, \\ \dots \end{array} \right\}$

This technical problem doesn’t arise in a framework where F-values are always non-nested sets. The standard implementation of Rooth’s alternative semantics respects this condition. However, given the above discussion, it appears that we could gain some analytical mileage by violating this standard assumption—that is, by allowing nested alternative sets.

Happily, it is not hard to formulate a generalized version of squiggle that can handle nested F-values. Note that while the proposition *Fred brought the beans* isn’t a member of the F-value in (47b), it is a member of a *member* of that set. Thus, we can generalize squiggle as follows:

(48) **Generalized Squiggle**

- a. $[\sim \phi]^o = [\phi]^o$
- b. $[\sim \phi]^f = \{[\phi]^o\}$
- c. ... and presupposes that the context contain an antecedent C such that:
 - i. $C \subseteq [\phi]^f$
 - ii. $|C| > 1$
 - iii. $[\phi]^o * \in C$ “C contains $[\phi]^o$ somewhere within it.”

The only modification necessary was to clause (c.iii). The new condition is loosened to require only that $[\phi]^o$ occur *somewhere within* C, using the “ancestral membership” relation discussed by Quine (1963: §15), who traces the definition of the ancestral and the star notation to Frege’s (1879) *Begriffsschrift*. This modification is conservative in the sense that it has no effect on standard cases where the F-value is non-nested. However in the case of a nested focus value, the new squiggle will enforce congruence of an answer to a sorted question or discourse strategy.

Let’s pause for a moment to clarify the intention behind our continued use of the term “discourse strategy”. Remarkably, the notion of anaphora to a sorted question that we’ll be relying on from here onward doesn’t require any dedicated formal mechanism for encoding discourse strategies. With Hagstrom (1998: 148), we can take sorted questions to be first class semantic objects—literally questions in every sense. As a result, the proposal to analyze CT as focus anaphora to a sorted question is ambivalent as to whether we adopt a framework like Roberts’ (1996) that gives strategies an independent life as formal pragmatic objects. If we did adopt Roberts’ model, the link between a sorted question and a discourse strategy would be fairly direct. Following Hagstrom (1998), we understand the effect of asking a sorted question to be equivalent to asking all of its sub-questions. Thus, a sorted question would have the effect of requiring the discourse to proceed along the lines of a particular strategy of sub-questions. Going forward, I will refer interchangeably to CT construc-

tions as implying either sorted questions or discourse strategies, and I will continue to use d-trees to illustrate the hierarchical structure of discourse. This presentational choice aims to ease comparison with work in the Roberts/Büring tradition, without necessarily taking on the theoretical commitments of these models.

We’ve now seen that a general squiggle operator can, in theory, be used to capture facts about what type of discourse strategy an answer is congruent to. This is a promising result, but it doesn’t do us any good until we have a semantics that permits nested focus values in the first place. On Rooth’s system, there is no way a declarative could ever actually have the focus value in (47b). Specifically, Rooth’s (1985: 54–56) principles of composition guarantee that the F-value of any expression ($\llbracket \phi \rrbracket^f$) is a non-nested set whose members are the same type as the ordinary semantic value of the expression ($\llbracket \phi \rrbracket^o$).³³ In the following section I propose a formal mechanism for generating nested F-values like the one in (47b).

3.2.3 Topic Abstraction

The major innovation I would like to propose is the introduction of an operator that adds a layer of nesting in the focus dimension by abstracting over alternative sets, as in (49). I will refer to this operator as the TOPIC ABSTRACTION OPERATOR, or the “CT operator” for short—for reasons that will become clear shortly. I will abbreviate it as CT- λ .

³³We can prove this inductively, since lexical items all have non-nested sets as their F-values (e.g. $\llbracket \text{John} \rrbracket^f = \{\text{John}\}$), and pointwise composition rules guarantee that the F-values of complex constituents are no more or less nested than the F-values of their parts.

(49) **Topic Abstraction**

- a. $\llbracket \text{CT-}\lambda_i \phi \rrbracket_g^o = \lambda x. \llbracket \phi \rrbracket_{g[i \rightarrow x]}^o$ (Ordinary Semantic Value)
- b. $\llbracket \text{CT-}\lambda_i \phi \rrbracket_g^f = \{ \lambda x. \llbracket \phi \rrbracket_{g[i \rightarrow x]}^f \}$ (Focus Semantic Value)

Like standard predicate abstraction, topic abstraction is formulated as a special non-compositional rule of interpretation. It would be impossible to achieve the effect we want otherwise; our goal is to create nesting in the focus dimension, and we've already seen that regular focus composition guarantees this will never happen.

The similarity with predicate abstraction doesn't end there. In fact, in the ordinary dimension, topic abstraction simply restates the usual predicate abstraction rule. The operator combines with an arbitrary expression ϕ , and is indexed to bind one or more designated variables (traces or pronouns) of arbitrary type τ within that expression. The effect of the abstraction is to output a function that takes an argument x of type τ and returns the interpretation of ϕ evaluated relative to an assignment where the coindexed traces receive the value of x .

The novel effect of topic abstraction is in the focus dimension. Here, the operator returns an alternative set containing a function from D_τ to alternative sets, as shown in (50a).³⁴ This function is a “seed” for creating nested alternative sets. When the singleton set output by CT- λ combines pointwise with a set of alternatives of type τ , these alternatives saturate the argument of the seed function and the result is a set of

³⁴I assume here and elsewhere that our type ontology includes (i) basic types like entities, truth values, and possible worlds, (ii) sets of objects of any type, and (iii) functions to and from any type. While it is often useful to think of a set and its characteristic function as equivalent, we still need to distinguish between sets and functions at the formal level. For instance, the set $\{\text{John, Mary, Sue}\}$ is a set of individuals, and is distinct from the function $\lambda x. x \in \{\text{John, Mary, Sue}\}$. The first is an alternative set, and can compose with another alternative set through pointwise composition. The second is a property, and can only combine through regular (non-pointwise) composition—e.g. with an argument via function application to produce a truth value.

alternative sets. This is illustrated in (50b), where the ‘+’ symbol stands for pointwise composition—in this case pointwise function application.³⁵

$$\begin{aligned}
 (50) \quad & \text{a. } \llbracket \text{CT-}\lambda_3 [t_3 \text{ sneezed}] \rrbracket^f \\
 & \quad = \{ \lambda x. \{ x \text{ sneezed} \} \} \\
 & \text{b. } \llbracket [\text{Fred}]_F [\text{CT-}\lambda_3 [t_3 \text{ sneezed}]] \rrbracket^f \\
 & \quad = \{ \text{Fred, Mary, ...} \} + \{ \lambda x. \{ x \text{ sneezed} \} \} \\
 & \quad = \{ \{ \text{Fred sneezed} \}, \{ \text{Mary sneezed} \}, \dots \}
 \end{aligned}$$

As it happens, the operator in (49) was rejected by Novel and Romero (2010: 326) as a candidate for normal predicate abstraction, for precisely the reason that it generates problematic “higher-order” alternatives.³⁶ The problem for Novel and Romero is that functions to alternative sets can’t serve as arguments to generalized quantifiers. For example, in the sentence “Who saw nobody?”, the GQ *nobody* can’t combine with the function from individuals to sets of propositions $\lambda x. \{ y \text{ saw } x \mid y \in D_e \}$. This sort of type clash with quantifiers still arises on the topic abstraction account, but I argue in chapter §4 that this is a virtue, as the problematic readings are not attested.

Finally, as with predicate abstraction, we need to ensure that the syntactic component of the grammar can generate structures interpretable by topic abstraction. One such structure is shown in (51). Here, the phrase *Fred* has been raised from its base position to directly above the CT- λ operator position, leaving a trace coindexed with the binding operator. This movement is parallel in function to quantifier raising (QR), which leaves a structure interpretable by predicate abstraction.

³⁵Here, as usual, I’m using English-style sentences like “*x sneezed*” to stand for propositions like $\lambda w. \text{sneezed}(x)(w)$.

³⁶For more on the challenge of defining the effect of normal predicate abstraction in the focus dimension, see Kratzer and Shimoyama (2002: fn. 3), Shan (2004) and Novel and Romero (2010). Note that Rooth’s (1985: 49–56) official proposal avoids the problems discussed by these authors by treating all denotations as functions over assignment functions.

(51)

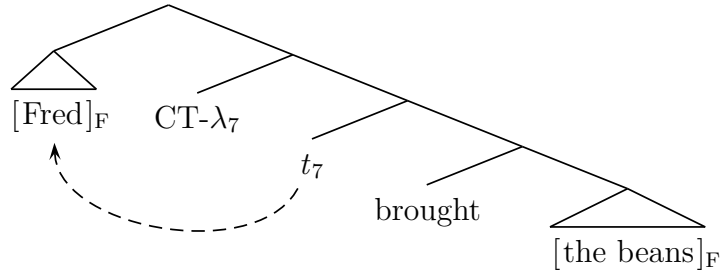

We will have more to say about this movement operation shortly. But let's first see what the semantic effect of topic abstracting *Fred* has been. As far as ordinary semantic values are concerned, topic abstraction is vacuous.³⁷ So the ordinary semantic value of the LF in (51) is just the proposition *Fred brought the beans*.

The composition of the focus value is where things get interesting, and this proceeds as shown in (52). The F-value output by the topic abstraction operator is a singleton containing a function that takes an individual x and returns the question *What did x bring*. When we combine this set pointwise with the F-value of the phrase $[Fred]_F$, we get the set of questions *What did Fred bring*, *What did Mary bring*, and so on.

(52)

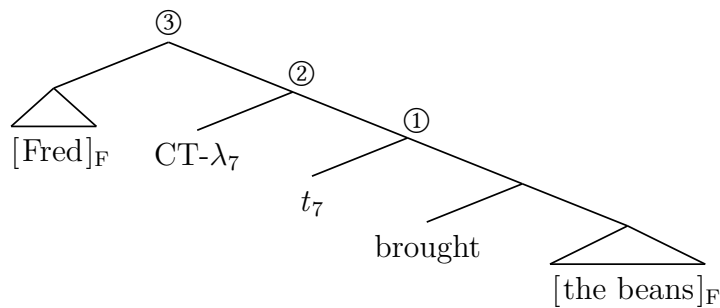

- a. $\llbracket \textcircled{1} \rrbracket_g^f = \{ g(7) \text{ brought the beans, } g(7) \text{ brought the pasta, } \dots \}$
- b. $\llbracket \textcircled{2} \rrbracket^f = \{ \lambda x. \{ x \text{ brought the beans, } x \text{ brought the pasta, } \dots \} \}$

³⁷The effect is the same as if we applied quantifier raising (QR) to a type-e expression. We abstract over an argument position, but then only use the abstraction to plug the original value of the argument back in, leaving us where we started.

$$\begin{aligned}
\text{c. } \llbracket \textcircled{3} \rrbracket^f &= \left\{ \begin{array}{l} \{ \text{Fred brought the beans, Fred brought the pasta, ...} \}, \\ \{ \text{Mary brought the beans, Mary brought the pasta, ...} \}, \\ \dots \end{array} \right\} \\
&= \text{For each person, what did they bring?}
\end{aligned}$$

By topic abstracting the phrase $[\text{Fred}]_F$, we have created a nested focus value that contains a set of questions varying in the position of *Fred*. In other words, the focus value is a complex question or strategy, sorted by the topic-abstracted argument.

The payoff we get from all of this is that we can use this focus value to mark congruence to a discourse strategy, without any additional stipulation. As with standard question-answer congruence, we assume a wide-scoped squiggle operator in the LF, as in (53a).³⁸ The F-value of squiggle’s complement (identified as ϕ) is shown in (b).

- (53) a. $\sim [\text{Fred}]_F \text{ CT-}\lambda_7 t_7 \text{ brought } [\text{the beans}]_F$
b. $\llbracket \phi \rrbracket^f = \text{For each person, what did they bring?}$

Following the discussion from §3.2.2, the effect of (generalized) squiggle in (53) is to presuppose a sorted question antecedent. Specifically, the discourse will have to contain a question made up of multiple questions of the form “What did x bring?”, one of which is the question “What did Fred bring?”. Thus, topic abstracting *Fred* results in the interpretation of *Fred* as CT. In sum, we have recreated the effect of Büring’s congruence condition using the more general squiggle, and found a way of marking which phrase is CT without resorting to CT-marks.

³⁸When representing phrase structures as bracketed linear strings, I assume binary right-branching unless otherwise indicated. Thus, the LF in (a) below is shorthand for the more explicit structure in (b). This is just the tree structure shown in (52), with the addition of a squiggle at the top.

- (i) a. $\sim [\text{Fred}]_F \text{ CT-}\lambda_7 t_7 \text{ brought } [\text{the beans}]_F$
b. $[\sim [[[\text{Fred}]_F [\text{CT-}\lambda_7 [t_7 [\text{brought } [\text{the beans}]_F]]]]]]$

To be explicit, my proposal is that (53) is the logical form of the English CT+Exh sentence “[Fred]_{CT} brought [the beans]_{Exh}”. More generally, my claim is the following:³⁹

(54) CT phrases are interpreted in a position directly above the CT- λ operator.

3.2.4 CT Raising

The last piece of the analysis that needs to be fleshed out concerns the syntactic details of how we build topic abstraction structures in the first place. I propose to allow a “CT RAISING” operation that mirrors quantifier raising (QR), as in (51) above. Like QR, this movement leaves a trace behind, and adds a coindexed lambda binder directly below the landing site. The difference is that CT raising creates a topic abstraction operator instead of the normal abstraction operator.

In fact, motivating CT raising in the syntax is somewhat easier than motivating QR, since we see direct evidence of CT movement in overt topicalization structures like (55), where the moved constituent is necessarily interpreted as a contrastive topic. I use a solid movement arrow here to indicate overt movement. Thus, the structure in (55b) corresponds to both the logical form and the surface word order of the CT+Exh sentence in (55a).

³⁹This claim should not be taken as a stipulation of the theory, since the notion of “CT phrase” has no independent formal status. Rather, the claim is an observation about where phrases matching the pre-theoretical notion of CT are uniformly interpreted on the topic abstraction model.

(55) a. [The BEANS]_{CT} ... [FRED]_{Exh} brought.
 L+H* L-H% H* L-L%

b.

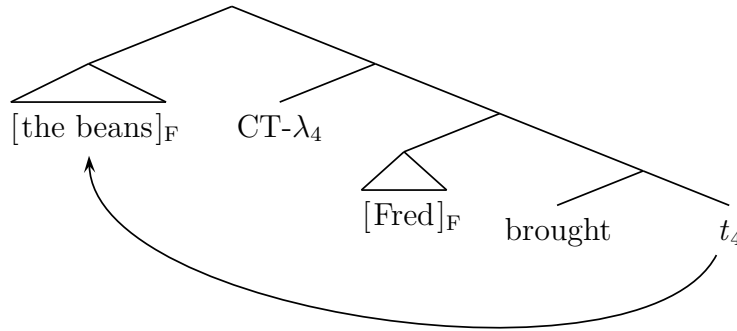

As the contrast between (56) and (57) shows, overt topicalization is natural when the moved phrase is interpreted as CT, but unnatural (regardless of the prosody) when the moved phrase is interpreted as exhaustive focus. This suggests the possibility that English topicalization could generally be understood as overt raising to the CT-λ position (although we shouldn't rule out the possibility of unrelated operations resulting in the same word order).

(56) A: What about the beans and the salad?

Who brought *those*?

B: [The BEANS]_{CT} ... [FRED]_{Exh} brought.
 L+H* L-H% H* L-L%

(57) A: What did Fred bring?

B: #The beans, Fred brought.

While CT raising can be overt, we also need to leave open the option for it to be covert, as with QR. For example, to get the right interpretation of an Exh+CT structure like (58a), we need the object to undergo CT raising at LF, while still being pronounced in situ. I indicate covert movement (affecting LF, but having no effect on surface word order) with a dashed arrow, as follows:

- (60) a. [FRED]_{Exh} sneezed.
 H* L-L%
- b. [FRED]_{CT} sneezed...
 L+H* L-H%

In chapter §5, I propose to account for the effect of covert (and overt) CT raising on English prosody by treating the CT- λ operator as a clitic with phonological content. This style of account is also promising for languages that have CT particles. Chapter §7 proposes that the Mandarin CT particle *-ne* is a realization of the CT- λ operator, and explores a similar analysis for the Paraguayan Guaraní particle *-katu*.

By comparison, QR doesn't have any robust effect on the realization of a sentence. For example, the unmarked pronunciation of (61) is ambiguous as to whether the object has undergone QR or not, resulting in a scope ambiguity.⁴⁰

- (61) Few of us had read the majority of the books.
- a. LF: [few of us] had read [the majority of the books]
 ‘Few of us had the property of having read most of the books.’
- b. LF: [the majority of the books] λ_4 [few of us] had read t_4
 ‘Most of the books had the property of having been read by few of us.’

We know that these are distinct readings since neither entails the other—that is, we can find contexts where each is true while the other is not. Figure 3.1 illustrates two contexts of this kind by linking people to the books they've read. If we understand the letters A–E as people and the numbers 1–5 as books, then reading (a) is true, while reading (b) is false. On the other hand, if letters are books and numbers people, then (b) is true and (a) false.

⁴⁰The logical forms in (61) are schematic, and ignore the fact that on many theories of quantification, the object will have to QR to avoid a type crash. In this case, the difference between the (a) and (b) readings comes down to which of the two quantifiers QRs to a *higher* position.

abstraction. Another possibility is to base generate a CT phrase directly above the CT operator, binding a coindexed pronoun in a lower argument position. This would allow us to interpret LEFT-DISLOCATION structures as equivalent to the (overt and covert) CT raising structures discussed above. For example, the sentence in (63a) could be interpreted as in (63b). While it’s well documented that left-dislocated elements aren’t *always* interpreted as CTs (Prince 1998, Gregory and Michaelis 2001, Manetta 2007), this is nevertheless one interpretation available to them, and topic abstraction provides a straightforward way of deriving it.

- (63) a. [The BEANS]_{CT} ... [FRED]_{Exh} brought them.
 L+H* L-H% H* L-L%
- b. [the beans]_F CT-λ₅ [Fred]_F brought them₅

One may wonder, is it feasible to use the same type of abstraction structure that we’ve been relying on so far in cases where the CT phrase is larger than a single argument—e.g. a predicate or the entire clause? By hypothesis, to get the desired meaning, we would need the entire CT phrase to be interpreted in the CT position, binding a high-order trace below.⁴¹ For instance, for sentential CT, we would make use of a propositional-type trace, as follows:

- (64) a. [It’s RAINING]_{CT} ... (but at least it’s not snowing.)
 L+H* L-H%
- b. [it’s raining] CT-λ₃ t_{3(s,t)}

While I see no direct evidence (other than the CT meaning itself) that the clause in (64a) is interpreted in a left-peripheral operator position, I also see no reason to rule out an LF like (64b). As for how to generate this structure in the syntax, we again have two options: either we topicalize the entire clause, or else we base-generate the

⁴¹See Heim and Kratzer (1998: 212–213) for a formal system that allows the binding of higher-order traces.

entire clause in the CT position. I leave it to future research to establish whether one or both of these structures is viable in English and other languages.

In the case of predicate CT, we do find tangible evidence that the CT phrase is associated with a higher position in the clause. As Lee (2003) documents for a range of languages (Korean, Japanese, Chinese, Italian, Russian, Turkish and Hungarian), predicate contrastive topics are often realized by raising a nominalization of the verb to the left periphery, and leaving a copy or a dummy verb below to carry the inflection. For instance, in the following Korean example, CT results in copying of the intransitive predicate:

(65) (Has she arrived and gone on stage?)

O-ki-nun o-ass-e.
come-NMLZ-CT come-PAST-DECL

‘She’s [arrived]_{CT}... (but she hasn’t gone on stage yet.)’ (Lee 2003: ex. 48b)

Landau (2006, 2007) discusses similar facts in Hebrew, where not only the verb, but also other pieces of the predicate may move or copy to the left periphery.⁴² With Landau, I assume that such structures are created via copy movement, and the lower copy is interpreted as a property-type trace. Overall, broad CT is not an inherent problem for the topic abstraction account, and in the specific case of predicate CT, the prevalence of (copy-)movement cross-linguistically provides further support for an analysis that interprets CT phrases in the left periphery.

Finally, we should ask what, if anything, needs to be said about the position of the CT- λ operator in the syntax. In fact, the semantics of topic abstraction already imply a fairly restricted distribution for the operator. Unless we introduce non-standard composition rules, the nested focus values produced by CT- λ won’t be

⁴²While Landau doesn’t provide an explicit discussion of the pragmatic licensing conditions on Hebrew VP-fronting, the examples he discusses seem compatible at least with the hypothesis that this (partial) movement signals the predicate as CT.

able to compose with typical non-nested focus values.⁴³ For example, the subject and predicate in (66) can't combine using standard pointwise composition, since the F-value of *Fred* is a set of individuals, while the F-value of the predicate is a set of sets of properties, as shown in (67). Thus, in general, the only semantic options left open after the F-value has become nested are (i) adding a squiggle, and (ii) doing further topic abstraction, nesting further.⁴⁴

(66) $[\text{Fred}]_F [\text{the beans}]_F \text{CT-}\lambda_6 \text{ brought } t_6$

(67) a. $\llbracket [\text{Fred}]_F \rrbracket^f = D_e$
 b. $\llbracket [\text{the beans}]_F \text{CT-}\lambda_6 \text{ brought } t_6 \rrbracket^f$
 $= \left\{ \begin{array}{l} \{\lambda x.x \text{ brought the beans}\}, \\ \{\lambda x.x \text{ brought the pasta}\}, \\ \dots \end{array} \right\}$
 c. $\llbracket (66) \rrbracket^f = \boxed{\text{CRASH!}}$

Given these interpretive restrictions it may not be necessary to stipulate a fixed syntactic position for CT- λ . While I leave the issue open here, it's worth pointing out that work in the cartographic tradition has converged on the view that CTs in non-argument positions do occupy a dedicated position in the left periphery (Rizzi 1997, Benincà and Poletto 2004, Haegeman 2006, Frascarelli and Hinterhölzl 2007, and Bianchi and Frascarelli 2010).

Regardless of how we explain why the CT operator sits where it sits, the topic abstraction account draws a tight connection between CT phrases and this position. If all CT phrases are interpreted at the CT operator position, then we gain an expla-

⁴³Hagstrom (1998: 141) discusses a rule of “flexible function application” that would allow the composition of a function expecting a single argument with a set value instead.

⁴⁴One more possibility would be to use the nested focus value to create a sorted question denotation, which could be asked directly, or be embedded as an indirect question. I discuss this possibility briefly in section §3.3.

nation for why cross-linguistically CT phrases are associated with this left-peripheral position.

3.2.5 Broad Assessment

This concludes our basic introduction to topic abstraction. On purely aesthetic grounds, I would argue that the topic abstraction account of CT meaning is preferable to Büring’s d-trees account. We have done without CT-congruence—a complex, stipulated condition whose effect is limited to sentences containing CT, yet seems to restate a pattern already encoded by Rooth’s squiggle. We have done away with CT-values—a new dimension of semantic meaning, demanding its own complex, stipulated set of composition rules. And finally, we have done without CT-marks in the syntax.

In the place of these CT-specific components, we relied on the general mechanism of focus anaphora, which, following Rooth, is hypothesized to be the only effect of focus. Just as simple cases of F-marking can mark congruence of an answer to a contextual question, more complex cases of F-marking can mark congruence to more complex kinds of questions, or discourse strategies.

In order to model focus anaphora to a sorted question, we had to permit nesting in the focus dimension. However this type of nested “set of questions” meaning had already been put to good use in the ordinary dimension—as a denotation for sorted readings of multiple *wh*- questions (Hagstrom 1998: §6). Thus, allowing focus values to also hold these meanings is not a large step, and could in fact be seen as a unifying move. We also had to adjust Rooth’s squiggle operator to handle these nested F-values, but this modification was conservative, leaving the predictions about standard examples intact. Thus, the only truly novel aspect of the formalism is the topic abstraction operator itself, and the associated QR-like movement responsible for creating topic abstraction structures in the syntax.

One cause for concern is that we haven't yet specified how the topic abstraction account connects up with facts about how CT sentences are realized—in terms of intonation in English, or other realizations in other languages. In Büring's system, we were able to exploit the mapping principle from section §2.2 to specify that CT-marked phrases get a particular prosody. However without CT-marks in the syntax, it isn't obvious how the phonological component of the grammar would go about identifying which phrase should receive a CT realization. This is a complicated issue that we'll return to in chapter §5. The finding there is that abandoning the mapping principle in favor of a more modular account leads to a more accurate picture of how CT is realized, in English and cross-linguistically. However these spell-out interface mechanics constitute a key part of the overall account, and should be factored in to any broad comparison of CT theories.

Regardless of which account is viewed as more parsimonious on a conceptual level, I would now like to present the case that the topic abstraction account is more empirically adequate. In particular, the account addresses the empirical challenges from section §3.1.

3.3 CT Questions

On the topic abstraction account, there is nothing to prevent the mechanism that gives a phrase a CT interpretation from applying in questions. In fact, if we plug in a simple semantics for questions, we can immediately capture the generalization from section §3.1.3 that cross-linguistically questions with overt CT marking are sub-questions within a strategy of contrasting questions, varying in the position of the CT phrase.

Since English doesn't display overt CT prosody in questions, it isn't possible to see the predictions of the account confirmed using English examples. However, to aid in exposition, I'll stick with pseudo-English sentences, and simply show what

meanings are generated if topic abstraction is applied in questions, without worrying about how this operation will affect the realization of the question in any particular language. We've already seen in section §3.1.3 that four languages (Czech, Japanese, Mandarin and Turkish) display overt reflexes of CT in questions. My assumption is that these reflexes can be explained in terms of how these individual languages spell out topic abstraction structures. We'll return briefly to the issue of why English lacks overt CT intonation in questions in chapter §5. Specifically, in section §5.10.2, I argue that while an English question *can* contain a CT operator, there is a surface constraint that prevents it from being realized, since questions already contain a tonal morpheme occupying the sentence-final position. This constraint parallels a constraint in Mandarin (see section §6.6.2) that prevents the CT morpheme *-ne* from surfacing in questions that are formed using the final question particle *-ma*.

To see how CT semantics play out in questions, we need to adopt a specific semantics for questions. Here, I'll adopt Beck's (2006) proposal that the alternatives making up a question are composed in the same dimension as focus alternatives. On Beck's account, *wh*- words generate a set of focus alternatives but have no ordinary semantic value. A question operator *Q* is used to transfer question meanings from the focus dimension into the ordinary dimension, roughly as follows:⁴⁵

⁴⁵For simplicity, I present the question operator here as unselectively binding all focus in its scope. Beck's actual implementation follows Kratzer (1991) in translating F-marked constituents using designated variables, and Wold (1996) in coindexing focus operators with the foci they bind. In this framework, it is possible to have *Q* selectively bind only coindexed focused phrases.

(68) **wh- Question Semantics**

(cf. Beck 2006: 15–16)

- a. $\llbracket \text{what} \rrbracket^o = \text{undefined}$
- b. $\llbracket \text{what} \rrbracket^f = D_e$
- c. $\llbracket Q \phi \rrbracket^o = \llbracket \phi \rrbracket^f$
- d. $\llbracket Q \phi \rrbracket^f = \llbracket \phi \rrbracket^f$

On this system, the logical form of a simple wh- question like “What did Fred eat?” is as in (69a).⁴⁶ Since the ordinary value of *what* is undefined, this undefinedness propagates up to the entire clause, as in (b). However the focus value of the clause (Q’s complement) is the desired question meaning in (c). The Q operator brings this meaning into the ordinary dimension, as in (d).

- (69) a. Q Fred ate what
- b. $\llbracket \text{Fred ate what} \rrbracket^o = \text{undefined}$
 - c. $\llbracket \text{Fred ate what} \rrbracket^f = \{ \text{Fred ate the beans, Fred ate the pasta, ...} \}$
 - d. $\llbracket Q \text{Fred ate what} \rrbracket^o = \{ \text{Fred ate the beans, Fred ate the pasta, ...} \}$

Given this treatment of questions, we can account for the meaning of CT questions using our established mechanism of topic abstraction. CT raising an F-marked phrase above the question operator leaves the ordinary semantic value of the question intact, while producing a sorted question F-value, as shown in (70). As in declaratives, this F-value can be plugged in to the squiggle operator to imply congruence to a set of contrasting questions that differ in position of the CT phrase.

⁴⁶The discussion throughout assumes a wh- in situ language, again using pseudo-English lexical items for convenience.

- (70) a. $[\text{Fred}]_F \text{ CT-}\lambda_5 \text{ Q } t_5 \text{ ate what}$
 b. $[[\cdot]]^o = \{ \text{Fred ate the beans, Fred ate the pasta, ...} \}$
 $= \text{What did Fred eat?}$
 c. $[[\cdot]]^f = \left\{ \begin{array}{l} \{ \text{Fred ate the beans, Fred ate the pasta, ...} \}, \\ \{ \text{Mary ate the beans, Mary ate the pasta, ...} \}, \\ \dots \end{array} \right\}$
 $= \{ \text{What did Fred eat? What did Mary eat? ...} \}$
 $= \text{For each person, what did they eat?}$

The same technique can be applied in yes-no questions. Given the assumption that a singleton set containing a proposition is a yes-no question denotation (discussed in section §2.3.3), the simplest way to achieve this is as follows:

- (71) a. $[\text{Fred}]_F \text{ CT-}\lambda_5 \text{ Q } t_5 \text{ came}$
 b. $[[\cdot]]^o = \{ \text{Fred came} \}$
 $= \text{Did Fred come?}$
 c. $[[\cdot]]^f = \{ \{ \text{Fred came} \}, \{ \text{Mary came} \}, \dots \}$
 $= \{ \text{Did Fred come? Did Mary come? ...} \}$
 $= \text{For each person, did they come?}$

Generalizing over these examples, the broad prediction being made is that CT questions are sub-questions within a strategy of questions varying in the position of the CT phrase (i.e. the F-marked phrase raised to the CT position). This fits with the use conditions of CT questions cross-linguistically, as described in section §3.1.3.

Just as overt topicalization examples provided support for the idea of CT raising in declaratives, we find examples of overt CT raising in questions. For instance, we already saw that Czech CT questions can mark the CT phrase through a dedicated syntactic configuration, raising the CT to the left periphery. Similarly, Mandarin CT questions can both display an overt CT particle as well as raising the CT phrase to the left periphery, as in (72):

- (72) NÈi běnr shū **ne**, nǐ kàn-wán le méi-yǒu?
 that CL book CT you read-finish ASP not-have
 ‘(And) [*that*]_{CT} book, have you finished (it)?’ (Chu 2006: 13)

The above analysis is enough already to capture the meaning of the kinds of CT questions we saw in section §2.3.3—ordinary wh- and yes-no questions that presuppose a larger sorted question antecedent in the discourse. Having dealt with the core data, we could stop here. However, I would also like to discuss a further potential application of topic abstraction in questions.

At this juncture, our model allows both questions and statements to have nested focus values, marking congruence to sorted question antecedents. Nothing in this analysis demands that any *overt* linguistic expression can denote a sorted question; focus anaphora would be satisfied simply by having the relevant sorted question meaning be salient in the context. However Hagstrom (1998) argues that natural languages do have the tools for representing sorted questions explicitly, and if this is right, then we need a way of composing sorted question meanings in the semantics.

So far, we’ve seen that topic abstraction can be used to generate sorted question meanings in the focus dimension, while leaving the ordinary dimension untouched. However topic abstraction also provides a simple way of generating sorted question denotations in the ordinary dimension. This can be achieved by topic abstracting a wh- constituent to a position below the Q operator.⁴⁷ In the simplest case, CT raising a wh- phrase in a single wh- question results in a sorted question denotation that breaks down the wh- question into a strategy of yes-no sub-questions. Thus the plain wh- question in (73a) and the CT wh- question in (73b) have different denotations.

⁴⁷Given the question semantics in (68), topic abstracting a wh- phrase *above* the Q operator would result in an undefined ordinary semantic value for the question as a whole.

(75) Context: This clock says 3:00, but that clock says 4:00.

Xiànzài dàodǐ jǐ-diǎn le **ne**?
now in.the.end how.many-o'clock ASP CT

‘What time is it, really?’ (elicited)

Just as topic abstracting a wh- word in a single question produces a meaning “sorted by” that wh- argument, the same operation in a multiple wh- question will have the effect of sorting one wh- word over another. The following pair illustrates:

(76) a. \llbracket Q who CT- λ_7 t_7 ate what \rrbracket^o = For each person, what did they eat?

b. \llbracket Q what CT- λ_8 who ate t_8 \rrbracket^o = For each thing, who ate it?

If structures like these underlie the sorted readings of multiple wh- questions, then the prediction is that we will find languages that disambiguate these readings via CT realization of one of the wh- words. Again, more work is needed to see if this prediction pans out. At the very least, there are a number of claims that different sorted readings of multiple wh- questions can be distinguished via word order, in the right language in the right circumstances. Šimík (2010) discusses Czech data and mentions Wachowicz 1974 for Polish, Kuno 1982 for English, É. Kiss 1993 for Hungarian, Comorovski 1996 for Romanian, and Jaeger 2004 for Bulgarian, each reporting judgments parallel to following English pattern:

(77) a. What did you buy where? = ‘For each thing, where did you buy it?’

b. Where did you buy what? = ‘For each place, what did you buy there?’

Dayal (1996), Hagstrom (1998) and Willis (2008) have discussion of similar English cases, seconding Kuno’s (1982) claim that the raised wh- word always corresponds to the “sortal key” (i.e. the element we’re sorting by) in sorted readings of multiple

wh- questions.⁴⁹ While various mechanisms have already been proposed for accounting for this type of data (see e.g. Dayal 1996 and Hagstrom 1998), one simple way of explaining contrasts like (77) would be in terms of CT raising the wh- phrase that corresponds to the sortal key. Such an analysis would fit with proposals by Willis (2008) and Šimík (2010) that topic-focus structure is realized overtly in multiple wh- questions and that the topical wh- element is the sortal key. However making this analysis stick in a given language would require a clear formulation of how CT movement and (non-CT) wh- movement compete and interact.⁵⁰ I leave this investigation to future research.

⁴⁹Since this type of judgment is difficult to access via intuition, it is important to test it experimentally. My own preliminary research suggests that the English facts are not as clear-cut as the judgment in (77) implies. In a pilot study on Amazon Mechanical Turk, subjects (self-reporting as from the US and speaking English as their first language) were asked to pick the best title for a list of frequently asked questions on a college admissions website. In condition A, the FAQ consisted of questions addressing where to send the green form, the blue form and the pink form. In condition B, the questions addressed what to send to the admissions office, to financial aid, and to the department of proposed major. Presented with a forced binary choice, the majority (69%) of condition A subjects (n=108) chose the title “Where to Send What”, whereas most (71%) condition B subjects (n=111) chose the title “What to Send Where”. Additional evidence that Kuno’s judgments aren’t robust (and may even go the other way) comes from web examples:

- (i) a. If you buy a lot of music, I might suggest you make a list like I have done, to keep track of when and where you bought what and how much it cost.
- b. Keeping tabs on where you bought what, how much you spent, and how the plants performed helps develop a personal reference source.
- c. The best you can do is observe the meat, take note of the marbling, and try to remember where you bought what, and what they called it.
- d. After breakfast our group went to a department store. It was very similar to like our Macy’s or Dillard’s except you had to pick out your item get a receipt pay for it and then go back to pick it up... it was hard to remember where you bought what.

⁵⁰Since we know that CT raising can apply covertly, it is not immediately clear how we would expect a CT wh- word to behave in the syntax, as compared to a non-CT wh- word. The most revealing data may come from languages that can raise more than one wh- item. Šimík (2010) mentions that in Hungarian and Bulgarian when multiple wh- words raise, the non-sortal element raises to a focus position, while the sortal element raises to a higher position (presumably a topic position).

3.4 Island Sensitivity

On the topic abstraction account, the way a phrase gets interpreted as a CT is by raising—either overtly or covertly—to the CT operator position (if it wasn’t generated there already). This immediately predicts sensitivity to whether a CT phrase occurs inside an island. Generally speaking, QR-like covert movement operations are observed to obey island constraints.⁵¹ For example, (78) and (79) show that quantifiers can’t scope out of coordinate structure or relative clause islands. Specifically, each bolded quantifier is unable to scope out of the bracketed island, and thereby unable to out-scope the sentence-initial quantifier.

- (78) a. Someone reported that [Max and **all the ladies**] disappeared.
 ≠ ‘Each lady is such that someone reported she and Max disappeared.’
- b. Many students believe anything [that **every teacher** says].
 ≠ ‘Each teacher is such that many students believe anything she says.’

(Reinhart 1997: 338)⁵²

⁵¹The picture is less clear with other covert movements. For example, Huang (1982a,b) discusses both cases of covert *wh*- movement in Chinese that do appear to show island sensitivity, as well as cases of the same covert movement appearing to violate island constraints. One way to approach these facts (although not the approach Huang takes) would be to maintain that LF movement is always island sensitive, and assume that covert pied-piping of the entire island structure is responsible for obviating the island violation. We will see below that this approach provides a satisfactory account of the contrast between cases where CT can appear in islands and those where it can’t.

⁵²A third example from Reinhart is “Someone will be offended if we don’t invite **most philosophers**”. However this example does in fact permit an (apparent) wide-scope reading of *most*, as shown in (i)—although this reading may be dispreferred out of the blue. This is expected on the view defended in chapter §4 that *most* allows a referential (i.e. non-quantificational) reading. On this reading, *most philosophers* is in fact a scopeless referential expression, so its referring to a fixed group across different values of *someone* is derivable without recourse to scope.

(i) (We’re only allowed to invite two philosophers, but no choice will make everyone happy. Someone will be offended if we don’t invite Searle. Someone will be offended if we don’t invite Austin. Someone will be offended if we don’t invite Quine. What can we do?)

SOMEONE will be offended if we don’t invite MOST philosophers!

- (79) Every problem [that **no man** could solve] was contributed by Mary.
 ≠ ‘No man is such that every problem he could solve was contributed by Mary.’
 (Heim and Kratzer 1998: 277)

At first glance, CT phrases don’t appear to obey island constraints. For example, in (80a), the CT *Fred* appears inside a coordinate structure island. However this alone isn’t a good reason to abandon the idea of LF movement. As (b) and (c) show, when CT raising is overt, the phrase that moves is the entire CT-containing island structure, not just the CT phrase alone.⁵³ Thus, if covert movement mirrors the overt movement facts, then (a) doesn’t involve any island violation.

- (80) (How would Fred or Sue be as a partner for Mary?)
- a. [FRED]_{CT} and Mary ... would be [GOOD]_{Exh} partners.
 L+H* L-H% H* L-L%
- b. [FRED]_{CT} and Mary ... I think would be [GOOD]_{Exh} partners.
 L+H* L-H% H* L-L%
- c. *[FRED]_{CT} ... I think ___ and Mary would be [GOOD]_{Exh} partners.
 L+H* L-H% H* L-L%

As far as the semantics of topic abstraction are concerned, it turns out to be inconsequential whether CT raising in (80a) targets the CT phrase alone or targets the entire island. The resulting LFs in (81) have the same denotations, in both the ordinary and focus dimensions. The focus value, given in (82), will result in congruence to a complex question of the kind we have in the setup for (80).

⁵³I’ve embedded these examples under ‘I think’ so that the overt movement isn’t string vacuous. This embedding could be added at the front of (a) as well, thereby guaranteeing that no overt movement has taken place, and making the parallel with (b) and (c) stronger. Adding this embedding wouldn’t affect the validity of any of the following arguments, but would make their exposition somewhat more complicated.

(81) a. $[\text{Fred}]_F \text{ CT-}\lambda_3 [t_3 \text{ and Mary}]$ would be $[[\text{good}]_F \text{ partners}]$

b. $[[\text{Fred}]_F \text{ and Mary}] \text{ CT-}\lambda_3 t_3$ would be $[[\text{good}]_F \text{ partners}]$

(82) $[[81a)]^f = [[81b)]^f$

$= \left\{ \begin{array}{l} \{ \text{Fred and Mary a good pair, Fred and Mary a bad pair, ...} \}, \\ \{ \text{Sue and Mary a good pair, Sue and Mary a bad pair, ...} \}, \\ \dots \end{array} \right\}$

= For each person, how would they be as a partner for Mary?

In sum, there appears to be nothing in the syntax or semantics preventing us from CT raising the entire island structure in (80a). Thus, if CT raising respects islands (which we'll see evidence for shortly), then the correct LF for (80a) must be the island-obeying structure (81b).

In this instance, we were able to avoid the island effect by pied-piping the entire island structure along with the moving CT phrase. However the use of pied-piping to obviate the island effect is not available across the board. The meaning equivalence between the two LFs in (81) depends on the fact that there is no other focused material within the island. Let's see what would happen in a case where the island contained additional F-marking. Consider the following variations on the LFs above, where the second focus falls on *Mary*, within the island, as opposed to *good*, outside.

(83) a. $[\text{Fred}]_F \text{ CT-}\lambda_3 [t_3 \text{ and } [\text{Mary}]_F]$ would be $[\text{good partners}]$

b. $[[\text{Fred}]_F \text{ and } [\text{Mary}]_F] \text{ CT-}\lambda_3 t_3$ would be $[\text{good partners}]$

In this case, the two LFs have different focus values, as shown in (84). If the F-marked *Mary* is left downstairs, it gets the semantics of an exhaustive focus, producing a CT+Exh sentence. On the other hand, if the entire island $[\text{Fred and Mary}]$ raises,

then the two F-marked phrases are treated on a par—as two CTs. In this case, the focus value is a set of yes-no questions varying in two positions. We’ll see how structures like these can be used to represent multiple CT examples in section §3.5.

- (84) a. $\llbracket(83a)\rrbracket^f$
- $$= \left\{ \begin{array}{l} \{ \text{Fred and Mary a good pair, Fred and Bill a good pair, ...} \}, \\ \{ \text{Sue and Mary a good pair, Sue and Bill a good pair, ...} \}, \\ \dots \end{array} \right\}$$
- = For each person, who would be a good partner for them?
- b. $\llbracket(83b)\rrbracket^f$
- $$= \left\{ \begin{array}{l} \{ \text{Fred and Mary a good pair} \}, \\ \{ \text{Sue and Bill a good pair} \}, \\ \dots \end{array} \right\}$$
- = For each pair of people, would they be good partners?

More generally, what we’re seeing is that topic abstraction semantics impart a CT interpretation to any focused phrase contained within the specifier of the CT operator.⁵⁴ Thus, we can give the following theory-internal definition of CT:

- (85) A CT phrase is an F-marked phrase within the specifier of the CT operator.

Given this generalization, the only way to distinguish CT from Exh island-internally would be to raise the CT phrase out of the island, as in (83a). Thus, on the assumption that CT raising respects islands, we derive a prediction that CT and Exh will never co-occupy an island. This prediction is borne out in the following examples, repeated from section §3.1.4. When CT and Exh occur within a single island, as in (86), the results are severely degraded. However if the sentence is rearranged so that the Exh

⁵⁴As with “complement”, I use the term “specifier” here loosely, to indicate the phrase that composes with the output of the CT operator.

phrase is island-external, as in (87), the same CT+Exh meaning can be conveyed without a problem.⁵⁵

(86) a. (What about Fred and Sue? Who should we pair each of *them* with?)

??[FRED]_{CT} ... and [MARY]_{Exh} would be good partners.
 L+H* L-H% H* L-L%

b. (What about Fred and Sue? Which of *their* drawings were the best?)

??The drawing [FRED]_{CT} ... did of [MARY]_{Exh} was the best.
 L+H* L-H% H* L-L%

(87) a. (What about Fred and Sue? Who should we pair each of *them* with?)

[FRED]_{CT} ... would be a good partner for [MARY]_{Exh}.
 L+H* L-H% H* L-L%

b. (What about Fred and Sue? Which of *their* drawings were the best?)

The best drawing [FRED]_{CT} did ... was the one of [MARY]_{Exh}.
 L+H* L-H% H* L-L%

Beyond the inability of CT and Exh to co-occur within a single island, we find evidence of island-sensitivity in the positioning of CT morphemes. For example, the contrast in (88), repeated from section §3.1.4, shows that Japanese CT *-wa* can't attach to CTs island-internally:

⁵⁵These facts directly parallel an observation made by Watanabe (1992) (crediting Mamoru Saito) and discussed by Richards (2000) concerning Japanese island-internal *wh*- phrases. Like the CT phrases above, Japanese *wh*- phrases are licensed island-internally but limited in where they can take scope by the presence of additional material within the island. Specifically, the observation is that when multiple *wh*- phrases occur island-internally, they are required to all take the same scope. This is again consistent with the view that the phrases in question undergo covert movement, and that this movement respects islands. For both CT and *wh*- phrases, the only way to “scope out” of an island is to pied-pipe the entire island structure, ruling out the possibility of distinct scopal interpretations for two island-internal phrases. (Recall that on the topic abstraction theory, the interpretive difference between CT and Exh stems from the fact that one takes scope at the level of the CT operator and one below.)

- (88) a. *Itsumo [CHOMSKY-**wa** kai-ta hon]-ga shuppan sa-re-ru.
 always Chomsky-TOP write-PAST book-NOM publish do-PASS-NONPAST
 ‘[The books that [*Chomsky*]_{CT} writes] are always published...’
- b. Itsumo [CHOMSKY-ga kai-ta hon]-**wa** shuppan sa-re-ru.
 always Chomsky-NOM write-PAST book-TOP publish do-PASS-NONPAST
 ‘[The books that [*Chomsky*]_{CT} writes] are always published...’
- (Hara 2006: 73–74)

On an in-situ theory of CT interpretation, it’s not clear why *-wa* would be restricted in this way. By contrast, on the topic abstraction account, the positioning of *-wa* is easy to capture. Building on a proposal by Davis (2010), we could say that *-wa* marks the phrase that undergoes CT raising.^{56,57}

Similar facts govern the distribution of the Mandarin CT marker *-ne*. As shown in (89), when a CT occurs island-internally, *-ne* can only occur at the edge of the island, never inside the island:

- (89) a. *[Wǒ ZUÓTIĀN **ne** kàn de shū] BÙ-HǎO-KÀN.
 I yesterday CT read DE book not-good-read
 ‘[The book that I read [*yesterday*]_{CT}] ... was [*bad*]_{Exh}.’
- b. [Wǒ ZUÓTIĀN kàn de shū] **ne**, BÙ-HǎO-KÀN.
 I yesterday read DE book CT not-good-read
 ‘[The book that I read [*yesterday*]_{CT}] ... was [*bad*]_{Exh}.’ (elicited)⁵⁸

⁵⁶This analysis treats Japanese *-wa* on a par with the Q-particles discussed by Cable (2007). In *wh*- questions, these particles occur at the edge of the moving constituent, which may be larger than the *wh*- element itself.

⁵⁷There are other options for explaining the island-sensitivity of *-wa* as well. See Hara (2006: 66) for one approach. The point I would like to make is just that positing CT raising in the derivation of Japanese CT sentences provides a particularly direct way of capturing the island facts.

⁵⁸The elicited Mandarin data throughout the dissertation come from my own interviews with native speakers, primarily young adults from northern mainland China. See the introduction to chapter §6 for further details.

In chapter §7, I present an analysis of Mandarin *-ne* as spelling out the CT operator itself. On this view, the material preceding *-ne* in (89b) has necessarily arrived there via CT raising, and therefore must be a single constituent, and cannot have raised out of an island.

Finally, as we observed earlier, the English L-H% component of the “CT contour” is also characterized by an inability to occur within islands. Whenever a CT appears island-internally, the associated L-H% boundary is always delayed until the right edge of the island. A detailed account of this effect is given in chapter §5. The basic idea is that, like Mandarin *-ne*, English L-H% is a lexicalization of the CT operator. However where this tonal material gets spelled out depends on the prosodic structure. I posit a prosodic constraint requiring the CT operator and its “associate” (the phrase undergoing CT raising) to be realized within a single intonational domain. This has the end result that L-H% will be delayed until at least the right edge of the CT-raised constituent, and hence at least to the right edge of any island containing the CT.

The point for now is not that this particular account of English CT realization is a convincing one, but just that the existence of covert CT raising makes it simple to formulate accounts that capture island sensitivity of English CT. More generally, we’ve seen that CT shows island sensitivity across several languages, and that this

falls out naturally on the topic abstraction theory, where CT raising is a prerequisite for CT interpretation (ignoring those CTs that are already base-generated high).^{59,60}

3.5 Multiple CT

In section §3.1.5, we saw that Büring’s model was unable to capture the contrast between the ABC diet examples repeated below in (90). The root of the problem was that Büring’s CT-value calculation ignores any scopal difference between CT phrases, flattening them all to a single level in the discourse structure. As a result, we can model congruence to a singly-nested strategy (i.e. a question with sub-questions), but not to a doubly-nested strategy (i.e. a question with sub- and sub-sub- questions).

(90) (On my new diet, every day I eat one avocado, one burrito and one cheesecake.)

- a. On [SUNDAYS]_{CT} ... [the BURRITO]_{CT} ... I have for [LUNCH]_{Exh}.
 L+H* L-H% L+H* L-H% H* L-L%
- b. The [BURRITO]_{CT} ... [on SUNDAYS]_{CT} ... I have for [LUNCH]_{Exh}.
 L+H* L-H% L+H* L-H% H* L-L%

On the topic abstraction theory, by contrast, the basic mechanism for distinguishing CT from Exh can be enlisted to distinguish one CT from another. Topic abstraction

⁵⁹There is a longstanding debate as to whether focus phrases *generally* undergo LF movement. See Anderson (1972), Chomsky (1976), Rooth (1985, 1992), Drubig (1994), Krifka (2006) and Wagner (2006a) for discussion. Part of that debate has looked at island (in-)sensitivity. It was observed that focus movement (if it existed) appeared to be immune to islands. However Drubig (1994) suggests that island-internal focus is interpreted via pied-piping the entire island structure, as I have assumed for CT. While a uniform treatment of all focus association as involving movement may be desirable, I would like to emphasize that the topic abstraction account doesn’t depend on it. Indeed, I’ve assumed throughout that exhaustive foci are F-marked phrases that remain in situ. At the same time, nothing would prevent us from implementing the topic abstraction account within a system where non-CT foci *also* move, as long as they move to a distinct position lower than the CT operator.

⁶⁰A remaining challenge is posed by examples like (i), where the smallest movable constituent containing the CT also contains a bound pronoun. If the whole constituent raises at LF, the pronoun is no longer in a position to be bound by the subject.

(i) [EVERY man_i]_{Exh} remembers [his_i [FIRST]_{CT} love]...
 H* L- L+H* L-H%

has the uniform effect of adding a layer of nesting in the focus dimension. If we apply topic abstraction once, we change a sentence’s F-value from a set of propositions to a set of questions, marking congruence to a strategy of simple questions—as on Büring’s model. If we apply the same operation again, the F-value becomes a set of sets of questions, and we predict congruence to doubly-nested strategies.

In the syntax, I assume that CT raising can apply multiple times per clause, and that multiple CT- λ landing sites are available. This assumption is in line with the standard view in the cartographic literature that there are arbitrarily many topic heads in the left periphery (see Rizzi 1997 and many following). The structure of a sentence where overt CT raising has applied twice is given below. This can serve as our representation of example (90a).

(91)

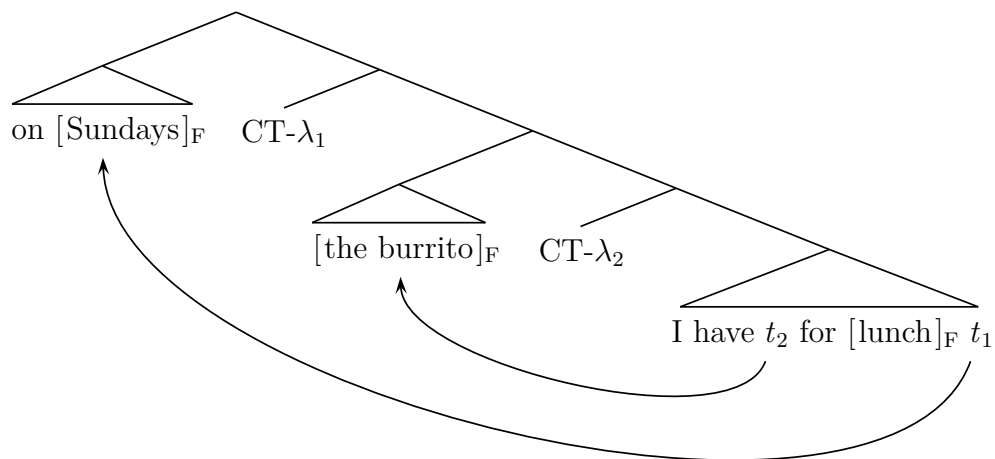

Whichever CT phrase is abstracted to the higher CT operator position will end up sorted out higher in the resulting discourse structure. For instance, the LFs in (92) have different focus values, as shown in (93).

- (92) a. [on [Sundays]_F] CT-λ₁ [the burrito]_F CT-λ₂ I have *t*₂ for [lunch]_F *t*₁
 b. [the burrito]_F CT-λ₁ [on [Sundays]_F] CT-λ₂ I have *t*₁ for [lunch]_F *t*₂

(93) a. $\llbracket (92a) \rrbracket^f$

$$= \left\{ \left\{ \left\{ \text{I have } y \text{ for } x \text{ on } z \mid x \in D_e \right\} \mid y \in D_e \right\} \mid z \in D_e \right\}$$

$$= \left\{ \left(\begin{array}{c} \left\{ \begin{array}{l} \{\text{Sunday burrito lunch, Sunday burrito dinner, ...}\}, \\ \{\text{Sunday avocado lunch, Sunday avocado dinner, ...}\}, \\ \dots \end{array} \right\} \\ \left\{ \begin{array}{l} \{\text{Monday burrito lunch, Monday burrito dinner, ...}\}, \\ \{\text{Monday avocado lunch, Monday avocado dinner, ...}\}, \\ \dots \end{array} \right\} \\ \dots \end{array} \right) \right\}$$

= For each day: [for each food, when do you eat it on that day?]

b. $\llbracket (92b) \rrbracket^f$

$$= \left\{ \left\{ \left\{ \text{I have } z \text{ for } x \text{ on } y \mid x \in D_e \right\} \mid y \in D_e \right\} \mid z \in D_e \right\}$$

$$= \left\{ \left(\begin{array}{c} \left\{ \begin{array}{l} \{\text{Sunday burrito lunch, Sunday burrito dinner, ...}\}, \\ \{\text{Monday burrito lunch, Monday burrito dinner, ...}\}, \\ \dots \end{array} \right\} \\ \left\{ \begin{array}{l} \{\text{Sunday avocado lunch, Sunday avocado dinner, ...}\}, \\ \{\text{Monday avocado lunch, Monday avocado dinner, ...}\}, \\ \dots \end{array} \right\} \\ \dots \end{array} \right) \right\}$$

= For each food: [for each day, when do you eat that food?]

When passed to the squiggle operator, these doubly-nested F-values translate into highly specific predictions for the shape of the surrounding discourse. For instance, the focus value in (93a) not only requires that the discourse contain further questions about when I have different foods on different days (as Büring’s model does), but also captures the fact that the speaker expects to deal with all the various Sunday-related issues as a group, before moving on to Monday. Thus, we predict an interaction between relative CT scope and the availability of different continuations. That is, we capture the continuation data from section §3.1.5, repeated here:

(94) On [SUNDAYS]_{CT} ... [the BURRITO]_{CT} ... I have for [LUNCH]_{Exh.}
 L+H* L-H% L+H* L-H% H* L-L%

- a. And the AVOCADO ... I have for DINNER.
- b. ??And on MONDAYS ... I have (it) for DINNER.

(95) [The BURRITO]_{CT} ... on [SUNDAYS]_{CT} ... I have for [LUNCH]_{Exh.}
 L+H* L-H% L+H* L-H% H* L-L%

- a. And on MONDAYS ... I have for DINNER.
- b. ??And the AVOCADO ... I have for DINNER.

Yet not every sentence with multiple CTs induces higher-order sorting of this kind. For instance, when two CTs occur within an island, there is no implication that one out-scopes the other, as evidenced by the availability of continuations that vary either or both of the CTs.⁶¹

(96) (How were the poems that the boys wrote for the girls?)

The poem that [FRED]_{CT} wrote [MARY]_{CT} ... was [CHARMING]_{Exh.}
 L+H* L- L+H* L-H% H* L-L%

- a. But the poem that Fred wrote *Sue* ... was *awful*.
- b. But the poem that *Bill* wrote Mary ... was *awful*.
- c. But the poem that *Bill* wrote *Sue* ... was *awful*.

In fact, the topic abstraction model is well-suited to account for these facts. Since neither *Fred* nor *Mary* can raise out of the island, the only way to give them a CT interpretation at all is by abstracting the entire island, as in (97).⁶² As we saw in section §3.1.4, this results in congruence to a singly-nested strategy of questions about

⁶¹It's not clear whether the phonological phrase break after *Fred* is mandatory here. I've included this break (marked with the L- boundary), in line with the baseline predictions of the interface model presented in chapter §5. However it would also be possible to adapt that model to allow for optionality of the break.

⁶²In this example, and with matrix subject CTs in general, it is not immediately obvious whether CT raising has applied overtly or covertly. However this issue is orthogonal to the present discussion, since the resulting LF is assumed to be the same in either case.

different pairs (e.g. Fred+Mary, Bill+Sue, and so on), rather than a doubly-nested strategy with one CT taking scope over the other. This singly-nested strategy is compatible with any of the continuations in (96).

(97) [the poem that [Fred]_F wrote [Mary]_F] CT- λ_8 t_8 was [charming]_F

Overall, we've seen that examples containing two CTs fall into two classes. In one case, each CT phrase raises to its own CT operator position, and each operator adds an extra layer of F-value nesting. I will refer to these cases as NESTED CT examples, since they involve a sequence of CT operators and one is “nested” within the scope of the other. In the other case, the CTs raise together to a single operator position. This configuration of one operator binding multiple foci is what Krifka (1992: 21) dubs COMPLEX focus. Thus, I will refer to this second class of examples as COMPLEX CT examples.

The possibility of both nested and complex CT configurations falls out automatically on the view that CT phrases are foci bound by a dedicated focus-sensitive operator. As Krifka (1992: 21) discusses, focus operators in general give rise to these two configurations.⁶³ For instance, (98) shows nested and complex focus configurations under the operator *only*, where the arrows indicate binding:

⁶³Krifka (1992) aims to reserve the term “multiple focus” for what I’m calling nested focus, but the distinction has not been taken up reliably by subsequent authors.

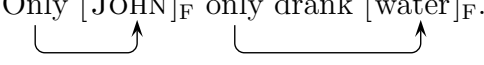
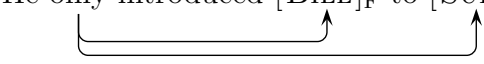
- (98) a. (Which of the guests only drank water?)
 Only [JOHN]_F only drank [water]_F. **Nested Focus**

- b. (What pairs of people did John introduce?)
 He only introduced [BILL]_F to [SUE]_F. **Complex Focus**

(cf. Krifka 1992: 21)

There are two remaining puzzles about multiple CT that I would like to bring up, although I won't be able to fully resolve them here. First, there is an issue concerning the scope options for multiple CTs when one or more CT phrase remains in situ. Consider the following example:

- (99) [The BURRITO]_{CT} ... I have for [LUNCH]_{CT} ... on [SUNDAYS]_{Exh}.
L+H* L-H% L+H* L-H% H* L-L%

While *the burrito* appears in a higher position than *lunch* on the surface, the topic abstraction model requires that *lunch* (or some containing constituent) also raises to a CT operator position. The crucial question is, what are the relative scopes of the two CT operators? The two logical possibilities are as follows:

- (100) a. [the burrito]_F CT- λ_1 [for [lunch]_F] CT- λ_2 I have $t_1 t_2$ [on [Sundays]_F]
 b. [for [lunch]_F] CT- λ_1 [the burrito]_F CT- λ_2 I have $t_2 t_1$ [on [Sundays]_F]

Without further stipulation, there is nothing constraining whether the covert movement of *for lunch* is to a position above or below *the burrito*. Thus, the baseline prediction is that (99) should be ambiguous between the two LFs in (100). However, the following continuation data seem to indicate that only the first LF is available.

- (101) [The BURRITO]_{CT} ... I have for [LUNCH]_{CT} ... on [SUNDAYS]_{Exh}.
 L+H* L-H% L+H* L-H% H* L-L%
- a. And (I have it) for DINNER on MONDAYS.
- b. ??And (I have) the AVOCADO (for lunch) on MONDAYS.

Based on this initial data, I hypothesize that in sentences involving both overt and covert CT raising, the overtly raised CT(s) must take scope above those raising covertly. I offer a prosodic account of this asymmetry between overt and covert movement in section §5.6.⁶⁴

The second puzzle I have in mind concerns cases like the (102). The issue is in deciding whether to treat this example as a case of nested CT or complex CT. Pragmatically speaking, we'll see there is reason to believe it is complex CT. However to allow this interpretation we would need to modify our semantics.

- (102) (What did Fred and Mary give each other?)
- [FRED]_{CT} gave [MARY]_{CT} ... [a UKELELE]_{Exh}. (Mary gave Fred ... a tie.)
 L+H* L- L+H* L-H% H* L-L%

Consider the following strategies as possibilities for the discourse structure implied by the intonation in (102):

⁶⁴The effect could be also be captured by Wagner's (2012) hard constraint that nested focus operators exhibit surface scope rather than inverse scope. However, this constraint is probably too strong to enforce in general (see footnote 82). A more flexible option would be to use Bobaljik and Wurmbrand's (2012) violable Scope Transparency constraint: "If the order of two elements at LF is A ≫ B, the order at PF is A ≫ B".

- (103) a. For each giver, what did they give each recipient? Nested CT
 b. For each giver-recipient pair, what was given? Complex CT

Suppose the exchange in (102) takes place in a context where exactly two gifts were given: one from Fred to Mary, and one from Mary to Fred. In this case, marking congruence to the doubly-nested strategy in (103a) seems to be overkill. While technically the two questions at issue (what Fred gave Mary and what Mary gave Fred) do fit this structure, the true organizational power of the strategy would be wasted. In particular, this strategy requires that we address all issues “What did Fred give x ?” before moving on to issues about what Mary gave people. Yet there is only one issue about what Fred gave anyone. Thus, even if we don’t rule this kind of congruence out on semantic grounds, it would plausibly be a bad choice pragmatically.⁶⁵

By comparison, the strategy in (103b) provides only as much structure as is needed for the task. Marking congruence to this strategy implies nothing more than the existence of a contrasting sub-question of the form “What did x give y ?”, implying no sorting of givers over receivers. Overall then, it seems plausible that (102) is a case of complex CT. But if this is right, then we’ll need to revise our topic abstraction rule.

Up until now, we’ve generated complex CT meanings by raising multiple CTs to a single operator as part of a larger constituent (e.g. an entire island structure). However, in this case, *Fred* and *Mary* are not contained within any constituent that doesn’t also contain the Exh phrase *a ukelele*.⁶⁶ Thus, if *Fred* and *Mary* are both interpreted as CT, they must raise separately.

⁶⁵We could actually rule out this strategy formally by modifying clause (c.ii) of the generalized squiggle operator in (48) to require that the antecedent C has cardinality ≥ 1 not just in its outermost shell, but at every non-inner-most layer of embedding. (Recall that our analysis of lone CT examples, following Büring, requires the possibility of singleton questions in the inner-most layer.)

⁶⁶While the structure of double-object constructions is widely debated, it is uncontroversial that the two objects occur within *some* constituent (e.g. VP) that excludes the subject.

If we raise the CTs to two distinct operator positions, we generate a nested CT interpretation, as we’ve already seen. Let’s assume that the syntax also permits raising two CT phrases to a single operator position. Unfortunately, as it stands, our topic abstraction operator can only abstract over one index at a time. Given these semantics, binding traces with distinct indices requires two operators, giving the unwanted nested interpretation. To allow a single CT operator to bind multiple indices, we would have to generalize our topic abstraction rule. One crude approach is to specify a separate composition rule for abstracting two CTs, as in (104). On this approach, (102) could have the LF in (105), and get a complex CT interpretation.

(104) **Complex CT Abstraction** (double abstraction case)

- a. $\llbracket \text{CT-}\lambda_{i,j} \phi \rrbracket_g^o = \lambda y \lambda x. \llbracket \phi \rrbracket_{g_{[j \rightarrow y]}}^{[i \rightarrow x]}$
- b. $\llbracket \text{CT-}\lambda_{i,j} \phi \rrbracket_g^f = \{ \lambda y \lambda x. \llbracket \phi \rrbracket_{g_{[j \rightarrow y]}}^{[i \rightarrow x]} \}$

(105) $[\text{Fred}]_F [\text{Mary}]_F \text{CT-}\lambda_{1,2} t_1 [\text{gave } t_2] [\text{a ukelele}]_F$

Of course, this solution would necessitate additional rules for abstracting three and four CTs, if such structures are licensed. It remains to be seen whether a general mechanism could be stated to avoid this redundancy. I also leave open the possibility that (102) could be treated as a degenerate case of nested CT, thereby eliminating the need for this kind of double-abstraction rule.

3.6 In Defense of a Unified Account

Following in the footsteps of Jackendoff (1972) and Büring (2003), the topic abstraction account aims for a unified theory of (at least) CT+Exh, Exh+CT and lone CT. In this section, I would like to address two recent critiques of this unified approach. The first critique, presented by Wagner (2012), claims that what I’ve been calling “lone CT” doesn’t actually fit with any intuitive notion of CT, and conveys something else entirely. The second critique, discussed by Constant (2012a) and Wagner (2012)

among others, is based on the observation that English Exh+CT and lone CT are typically unable to occur in STRATEGY-FINAL positions, and are unlike CT+Exh in this regard. Let's take these issues one at a time. To preview, I will argue that the first objection disappears under closer scrutiny. The second objection is an important challenge, but we'll see that the facts are not as clear-cut as previous work suggests. Finally, to conclude the section, I discuss evidence from other languages in favor of the unified account.

3.6.1 Sentential CT as a Limiting Case

The first critique nominally concerns lone CT examples, which are often referred to as having a “rise-fall-rise” contour. Wagner (2012) reports a vague but nevertheless important intuition that (i) lone CT examples have a special rhetorical effect, insinuating something extra, and that (ii) such examples don't seem to contain any contrastive topic, at least not in any intuitive sense. I reproduce below Wagner's assessment of the following example.

(106) A: Do you think Mary was involved in the candy store robbery?

B: She likes SWEETS... (Wagner 2012: 23)
 L+H* L-H%

The intuition about [(106)] is that the speaker is trying to insinuate something in addition to what is literally said, in this case maybe that yes, Mary *was* involved in the robbery. It is not clear in what sense a contrastive topic is at stake in this example, and arguably the use of this contour is orthogonal to the question of whether the sentence involves a contrastive topic or not. (Wagner 2012: 24)

The first point to notice about this criticism is that it can't hold of lone CT in general, only (perhaps) of sentential CT examples like (106). We've already seen examples of lone CT where nothing special seems to be insinuated and where it is easy to identify a particular phrase intuitively as a “topic” that “contrasts”. The following example, repeated from chapter §2 is one such case:

(107) A: Did Persephone and Antonio bring vegetarian dishes?

B: [PERSEPHONE]_{CT} brought one...
L+H* L-H%

Here the intonation seems to convey nothing more than “I’m answering the question about Persephone but not the one about Antonio”. This is a canonical case of CT meaning, and *Persephone* fits any reasonable intuitive definition of contrastive topic.

Is speaker B insinuating something extra here? Perhaps that Antonio is likely to have not brought a vegetarian dish? This is certainly possible. But it is no less possible with a parallel CT+Exh example like (108). Furthermore, in neither case is this or any extra insinuation mandatory. For instance, both (107) and (108) can be followed by “Antonio, I’m not sure about”.

(108) A: Did Persephone and Antonio bring vegetarian dishes?

B: [PERSEPHONE]_{CT} ... [DID]_{Exh} bring one.
L+H* L-H% H* L-L%

Thus, if anything, this first criticism would lead us to include lone CT as generally counting as a type of CT, but to exclude the specific sub-case of *sentential* lone CT. However in fact, even sentential CT can behave much more mundanely, given the right context. For example, in (109), speaker A poses two yes-no questions and speaker B answers just one of them, using a sentential CT contour. Here again, nothing extra is necessarily insinuated. And in terms of the intuitive notion of a contrastive topic, it seems reasonable to say that the speaker is addressing an issue about the possibility that it snowed, which contrasts with an issue about a different topic—the possibility that they closed the school.

(109) A: Did it snow yesterday and did they close the school?

B: [It SNOWED]_{CT}...
L+H* L-H%

So what are we to make of the more puzzling cases like Wagner’s candy store example? I would propose to apply the same kind of analysis I gave in section §2.3.3 of the following case:

(110) A: Did anything interesting happen today?

B: [FRED came over]_{CT}...
L+H* L-H%

CT always marks congruence to a question that is split into sub-questions. What’s noteworthy about cases like (110) and Wagner’s candy store example is that the decision of *how* to break up the larger question is made not by the question itself or the context, but rather by the CT-marked answer. For instance, when speaker A asked whether anything interesting happened, there’s no way she could have anticipated that her question would be broken down along the lines of the following strategy:⁶⁷

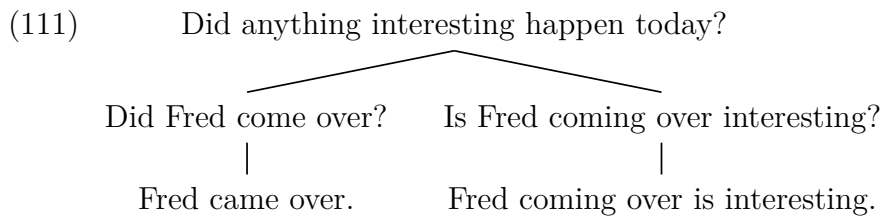

However, this feature is not unique to sentential CT or even to lone CT. CT+Exh can also be used to introduce specific sub-questions into the discourse. In (112), the choice to sort the issue of how everyone performed according to economic status is contributed solely by the CT utterance. Similarly, in Roberts’ murder example in (113), the need to address the larger issue of where *everyone* was—including specific

⁶⁷Nothing in the account forces the choice of the particular question “Is Fred coming over interesting?”. I have simply selected one sister question that has to the potential to resolve the dominating question, when combined with the information that Fred came over.

sub-questions about contrasting individuals—is due entirely to the CT utterance. It would be hard to maintain that this use of CT is any less insinuating than sentential CT examples.

(112) A: How did the students do on the test?

B: The [RICH]_{CT} students ... did [WELL]_{Exh.}
 L+H* L-H% H* L-L%

(113) A: Where were you on the night of the murder?

B: [I]_{CT} ... was [at HOME]_{Exh.}
 L+H* L-H% H* L-L%

In the end, I think the only pragmatic feature of sentential CT examples that can robustly distinguish them from other uses of CT is that the strategies they imply consist of *structurally unrelated* sub-questions. But this difference is exactly what is predicted by accounts like Büring’s or the topic abstraction model. For example, on Büring’s account, CT-marking the entire sentence is the only way to mark congruence to a strategy in which the sub-questions don’t have any structure in common. This kind of “free strategy” opens up a much wider range of possibilities for how a question can be broken up. For instance, it is only through this kind of strategy that I can attack a question like “Will it rain this afternoon?” by means of sub-questions like “Is the air pressure above 15 psi?” and “Are there nimbus clouds in the east?”. But we have no reason to rule out this kind of strategy, and in fact it would take extra stipulation to do so.

The ability to handle sentential CT is something we gain by moving away from intuitive notions of CT in terms of “aboutness”, “topicality” and “contrast”, and adopting a formal account. On accounts like Büring’s and the topic abstraction model, sentential CT data fall out as a natural limiting case, where intuitive notions of contrastive topic arguably fail us.

3.6.2 Constraints on Final and Repeated Answers

The second critique of the unified approach to CT is based on a claim that English Exh+CT and lone CT are unlike CT+Exh in that they demand non-resolution of the implied strategy being addressed. In other words, Exh+CT and lone CT are claimed to be bad in STRATEGY-FINAL positions, i.e. marking the answer to the final sub-question within a strategy. However, while I believe there is a grain of truth to this claim, the facts are more subtle than previous discussions have made clear. First, we'll see exceptions to this overall tendency, for both Exh+CT and lone CT. We'll also see that in the case of lone CT, the apparent restriction can be explained in terms of a more general constraint that applies equally to CT+Exh structures. Thus, in the end, it's not at all clear that we want or need to restrict Exh+CT and lone CT to non-final uses.

Before we turn to the data, I'd also like to point out that even if there were clear evidence that Exh+CT and lone CT resisted strategy-final uses, this wouldn't be incompatible with the view that they are genuine CT constructions with genuine CT meaning. There could very well be an independent interface principle that rules out sentences ending with rising intonation (e.g. L-H%) in discourse-final positions. In fact, this is the position advocated by Lauri Carlson (1984), who formalizes the constraint as follows:

(114) **Carlson's Generalization** (Carlson 1984: 314)

A sentence with non-final intonation cannot constitute an end point of a well-formed dialogue game.

Translated into our terms, this constraint might say "A sentence ending with L-H% can't stand as the answer to the final sub-question of a strategy." This would have the result of restricting the possible uses of Exh+CT and lone CT, while leaving CT+Exh uninhibited. Apart from the added complexity, there is no reason why something like Carlson's constraint couldn't work in tandem with a unified theory of CT like the one

Parallel to the Exh+CT cases, Constant (2012a) and Wagner (2012) discuss the inability of lone CT to occur strategy-finally as an obstacle to a unified treatment of lone CT (which they call “rise-fall-rise”) and other types of CT. The claim these authors make is that lone CT implies more than just a contrasting sub-question (as required by CT in general); it also requires that at least one contrasting sub-question remains to be answered. As a baseline, consider (120a), where the final CT+Exh clause succeeds in resolving the final sub-question of the larger issue. By comparison, in (120b), lone CT seems unable take on the role of resolving the final sub-question.⁶⁹ The basic intuition is that the final rising intonation in (120b) implies that some issue is still unresolved, and that the inability of the context to support this implication is what leads to infelicity.

(120) (Can Jack and Jill come over for tea?)

- a. [JACK]_{CT} ... [CAN]_{Exh}. [JILL]_{CT} ... [CAN'T]_{Exh}.
 L+H* L-H% H* L-L% L+H* L-H% H* L-L%
- b. [JACK]_{CT} can... ??[JILL]_{CT} can...
 L+H* L-H% L+H* L-H%

Similar restrictions have led some researchers to posit a “disputability condition” on the use of lone CT, or CT in general. For example, Büring (1997b: §3.2.2, 1999: 150–151) claims that a sentence with CT marking requires some “topic alternative” (i.e. a proposition within the sentence’s CT-value) to remain disputable after utterance. In other words, the CT-marked utterance should answer one sub-question but leave another sub-question unresolved. However this condition is clearly not enforceable in general, since it would rule out final uses of CT+Exh like (120a). It is presumably for this reason that the constraint is dropped from Büring’s (2003) later d-trees analysis.

⁶⁹This lone CT example is an extension of an example from O’Connor and Arnold (1973: 173), originally about Jack and *Bill*.

is expected, since the logic behind the Gricean implicature depends on the speaker having had the option of phrasing the two answers together. Consider the contrast between the two examples below. In (124), speaker B can be assumed to know her own kids' nationalities, and the repeated answer *Swiss* is unnatural. However, in a context where the responder is looking up answers one by one, as in (125), the repeated use of *Swiss* as Exh is acceptable, in spite of its givenness.⁷²

(124) A: What nationality are your kids?

B: Our [FIRST]_{CT} kid ... is [SWISS]_{Exh}.
 L+H* L-H% H* L-L%

??Our [SECOND]_{CT} kid ... is [SWISS]_{Exh}.
 L+H* L-H% H* L-L%

And our [THIRD]_{CT} kid ... is [FRENCH]_{Exh}.
 L+H* L-H% H* L-L%

(125) A: What nationality are her three kids?

B: Let me see.

<checking records> Her [FIRST]_{CT} kid ... is [SWISS]_{Exh}.
 L+H* L-H% H* L-L%

<checking records> Her [SECOND]_{CT} kid ... is [SWISS]_{Exh}.
 L+H* L-H% H* L-L%

<checking records> And her [THIRD]_{CT} kid ... is [FRENCH]_{Exh}.
 L+H* L-H% H* L-L%

So far, this all fits with the standard Gricean story. However, remarkably, it appears that the constraint against repeated answers is even stronger in discourse-final position. For example, in (126), repeating *Swiss* as the answer to the third and final sub-question is degraded, even in the context that we've just seen nullifies the implicature calculation:

⁷²This is support for theories that take into account the separate contributions of givenness and contrast in controlling the placement of pitch accents. For further discussion see Chafe (1976), Selkirk (2007) and Katz and Selkirk (2011).

(128) A: Do her three kids have Swiss citizenship?

B: Let me see.

<checking records> Her [FIRST]_{CT} kid does...
L+H* L-H%

<checking records> Her [SECOND]_{CT} kid does ...
L+H* L-H%

<checking records> But her [THIRD]_{CT} kid ... [DOESN'T]_{Exh.}
L+H* L-H% H* L-L%

(129) Replacing the last sentence of (128):

<checking records> ?? And her [THIRD]_{CT} kid does...
L+H* L-H%

Returning to our tea example, repeated below, we can now understand the infelicity of lone CT on the second clause as part of a general pattern restricting the use of repeated CT answers strategy-finally.

(130) A: Can Jack and Jill come over for tea?

B: [JACK]_{CT} can... ??[JILL]_{CT} can...
L+H* L-H% L+H* L-H%

As evidence against the view that lone CT is more broadly restricted against appearing strategy-finally, we can look at answer sequences that mix positive and negative responses. For instance, in (131), lone CT is licensed on what appears to be a strategy-final answer.

(131) A: Can Jack and Jill come over for tea?

B: [JACK]_{CT} [CAN'T]_{Exh.} But [JILL]_{CT} can...
 L+H* H* L-L% L+H* L-H%

Interestingly, the reverse order is odd, as (132a) below shows. However this can be explained in terms of an independent issue with lone CT on the negative answer, as in (b). Formally, this use of lone CT will produce a focus value containing a set of monopolar yes-no questions: { { Jack can't }, { Jill can't }, ... }. Without providing a formal analysis of the pragmatics of monopolar questions, it's not obvious whether a discourse like (132) would license focus anaphora to an antecedent subset of this F-value. However, it seems plausible that the infelicity of both (a) and (b) would derive from the lack of any overt or easily accommodated questions about whether people *can't* come over in the context.⁷³

(132) (Can Jack and Jill come over for tea?)

- a. [JACK]_{CT} can... ??But [JILL]_{CT} can't...
 L+H* L-H% L+H* L-H%
- b. ??[JACK]_{CT} can't...
 L+H* L-H%

In sum, we've seen there is a clear restriction against *repeated* lone CT answers (i.e. successive lone CT statements where nothing but the CT phrase has changed) both (i) in contexts where such answers cancel a Gricean implicature, and (ii) on the last answer of a list. These restrictions parallel observed restrictions on other uses of CT, suggesting that lone CT is "of a kind". Furthermore, initial evidence that lone CT isn't subject to *additional* restrictions against strategy-final uses can be found in responses like (131) that mix positive and negative answers. Thus, a convincing

⁷³One challenge for this view is the possibility of the conjoined answer:

- (i) [JACK]_{CT} can't... but [JILL]_{CT} can...
 L+H* L-H% L+H* L-H%

argument that lone CT examples need to formally convey non-resolution (unlike CT in general) would have to (i) explain in what sense the final answer in (131) is non-resolving, and (ii) bring forward clear cases where lone CT is illicit on a final answer and the infelicity can't be explained by independent restrictions on repeated answers.

Overall, while there is no shortage of examples where Exh+CT and lone CT are ruled out on final answers, it is still difficult to maintain that such cases are ruled out categorically, and a large portion of the problematic data may already be covered by independent restrictions. More work needs to be done to draw out the precise nature of the non-finality restriction, but at present, the data don't constitute a strong case for treating Exh+CT and lone CT in fundamentally different terms than CT+Exh.

3.6.3 Cross-Linguistic Support

All in all, the English data discussed in sections §3.6.1 and §3.6.2 can't be construed as particularly strong evidence for or against a unified theory of CT+Exh, Exh+CT and lone CT. We've seen that while lone CT sometimes appears to have an extra rhetorical "insinuating" effect, this is not a robust feature of lone CT, nor is it restricted to lone CT alone. We've also seen that while Exh+CT and lone CT are somewhat more restricted than CT+Exh in terms of their ability to occur discourse-finally, it's not clear that these restrictions are categorical, and in the case of lone CT, the restriction may derive from a more general constraint against repeated answers—a constraint that applies equally to CT+Exh examples.

Luckily, English isn't the only language to express CT meaning overtly. In the end, I think the question of whether Exh+CT and lone CT (including sentential CT) "qualify" as types of CT will be resolved by looking at other languages to see what range of examples CT realizations cover. On Wagner's (2012) view, it's a coincidence of English that lone CT bears the same prosodic contour as the CT portion of CT+Exh examples. Similarly, it's just an accident of English that what

I've called the "CT phrase" has a uniform prosodic realization across CT+Exh and Exh+CT sentences. However if we see these same accidents surfacing again and again in unrelated languages, they become harder to ignore.

With respect to lone CT, there is a solid and growing set of cross-linguistic facts that speak in favor of unification with other CT constructions. Languages with CT particles often extend those particles to mark cases of lone CT, showing the same pattern as English. For example, the Japanese and Mandarin CT particles occur in lone CT sentences, including sentential CT cases like the following:^{74,75}

(133) **Japanese Sentential CT**

A: Was the weather good?

B: AME-**wa** hut-ta-ga ...
rain-TOP fall-PAST-but

‘[It *rained*]_{CT} ... but (at least it wasn't cold).’ (Satoshi Tomioka, p.c.)

⁷⁴Heycock (2008) cites a similar example, mentioned by Kuno (1973) in a footnote:

- (i) Ame-**wa** hutte imasu ga kasa-**wa** motte ikimasen
rain-TOP falling is but umbrella-TOP take go.NEG
‘[It's *raining*]_{CT} ... but I'm not taking my umbrella with me.’

⁷⁵In the Japanese and Korean literature, it's widely accepted that the CT particles—CT *-wa* and CT *-(n)un* respectively—can occur in the absence of an exhaustive focus (see e.g. Heycock 2008 for Japanese and Lee 1999 for Korean, among many others). The analysis of Mandarin sentence-final *-ne* as CT is new, and will be presented in chapter §6. The Mandarin literature has paralleled much of the English literature in both (i) viewing sentence-final CT as unrelated to CT+Exh, and (ii) aiming to account for its effect in terms of notions of inconclusiveness or uncertainty (e.g. Alleton 1981, Tsao 2000).

(134) **Mandarin Sentential CT**

A: His family is poor, so you'd do better not to interact with him.

B: Tā jiā yǒu sān tóu niú **ne**.

his family have three CL cow CT

‘[His family has three *cows*]_{CT} ... (!)’

(Isn't that proof that they're not poor?)

(Tsao 2000: 16)

Furthermore, CT questions typically involve only a single CT, and no Exh. For instance, in the Mandarin example (135), the subject *tā* ‘he’ is marked as CT, and bears sentential stress, while the rest of the sentence lacks the prominence we would expect from an alternative-generating Exh focus. Thus, this too appears to be an example of a CT morpheme extending to mark lone CT:

(135) Nǐ dǒng le. Tā dǒng-bù-dǒng **ne**?

you understand ASP he understand-not-understand CT

‘You understand now. But does [*he*]_{CT} understand?’

(Chao 1968: 802)

With respect to Exh+CT, less data are available, and this is probably not a coincidence, since many languages are observed to restrict or forbid sentences where Exh precedes CT (see e.g. Buring 1997b: 65, Wagner 2012: 9 and Bobaljik and Wurmbrand 2012). However one useful data point comes from Tonhauser’s (2012) work on Paraguayan Guaraní. According to Tonhauser, the Guaraní morpheme *-katu* is a second position clitic that marks the existence of a contrastive topic somewhere within the clause. Interestingly though, neither the word order nor the prosody distinguishes *which* constituent is interpreted as CT:

- (136) A: Juana was born in Argentina. Where was Bob born?
 B: BOB-**katu** o-nasẽ ESTADO UNIDO-pe.
 Bob-CT A3-born America-in
 ‘[**Bob**]_{CT} was born in [the US]_{Exh}.’ (Tonhauser 2012: ex. 25a)
- (137) A: Juana was born in Argentina. Who was born in the US?
 B: BOB-**katu** o-nasẽ ESTADO UNIDO-pe.
 Bob-CT A3-born America-in
 ‘[Bob]_{Exh} was born in [**the US**]_{CT}.’ (Tonhauser 2012: ex. 25b)

Incidentally, the topic abstraction account makes it easy to capture the behavior Tonhauser describes here. We can simply say that *-katu* spells out the CT operator, and cliticizes to the first available prosodic unit (irrespective of whether that corresponds to the CT phrase it binds or not). But whatever the details of their analysis, data like these strengthen the case that Exh+CT and CT+Exh are related constructions that will be realized in related (or even identical!) ways within a language.

All in all, much more work needs to be done to test the degree that CT realizations extend to lone CT and CT+Exh across languages. Once this work is done, it will provide some of the most direct evidence for or against unification.

3.7 Other Configurational Approaches

Several recent approaches to contrastive topic share with the topic abstraction account the claim that CT phrases are just focused phrases in a particular configuration. In this section, I review two prominent configurational approaches, due to Tomioka (2010b) and Wagner (2012), and compare their predictions to those of the topic abstraction model.

3.7.1 Comparison with Tomioka 2010b

Tomioka (2010a and mainly 2010b) presents a theory of contrastive topic that shares certain features with the topic abstraction account, but is also different in several important regards. The first similarity, as discussed above, is that both theories are “configurational”. That is, a CT phrase is taken to bear the same F-marking as other alternative-generating elements, and is distinguished purely in terms of where it sits in logical form and what operators bind its alternatives. A deeper connection between Tomioka’s model and the topic abstraction model is that contrastive topics are taken to associate with a dedicated CT operator that takes wide scope. In fact, for Tomioka, the CT operator scopes above the level of the speech act, and functions to evoke alternative speech acts. This analysis makes it simple to handle CT in questions, which will be taken to evoke alternative question acts. (The issue of exactly how these alternative speech acts are used by the formal semantic/pragmatic system is left open by Tomioka, so I won’t say anything more specific about it here.)

Unlike the topic abstraction account, but like Büring’s d-trees model, Tomioka’s account interprets focus (and hence CT) in-situ. This is achieved under Wold’s (1996) framework for selective focus binding, building on Kratzer’s (1991) reformulation of Rooth’s in-situ theory of focus. In Wold’s system, focus operators are coindexed with the foci they associate with. For instance, the sentence in (138a) is represented by the LF in (b), where *only* is coindexed with the F-mark on its associate *Sue*.

- (138) a. John only introduced SUE to Bill.
b. only_4 John introduced $[\text{Sue}]_{F_4}$ to Bill

Unlike earlier in-situ theories of focus interpretation, this framework is compatible with “long distance” focus association across intervening operators. Thus, for example, *also* in (139) can bind just the alternatives to *Bill*, while *only* can bind just the alternatives to *Sue*.

(in a sense that Tomioka leaves open), where the alternatives vary in both the CT and Exh positions. Formally, the operators are defined as follows:⁷⁷

(141) **Tomioka’s CT and Exh Operators** (cf. Tomioka 2010b: 124)

- a. $\llbracket \text{CT}_i \alpha \rrbracket^g = \{ \llbracket \alpha \rrbracket^{g[i \rightarrow x]} \mid x \in D_\tau \}$ “evokes alternative speech acts”
- b. $\llbracket \text{Exh}_i \phi \rrbracket^g = \lambda w. \llbracket \phi \rrbracket^g(w) = 1$
 $\& \forall p \in \text{NW}(p, \{ \llbracket \phi \rrbracket^{g[i \rightarrow x]} \mid x \in D_\tau \}): [p(w) = 0]$
- c. $\text{NW}(p, S) = \{ q \mid q \in S \ \& \ p \not\subseteq q \}$ “propositions in S not weaker than p ”

Applied to our familiar CT+Exh example in (140), the output of the Exh operator will be the proposition that Fred ate the beans and ate nothing else. The assertion operator translates this proposition into a speech act, which the whole utterance will count as a performance of.⁷⁸ Finally, the CT operator evokes the following set of alternative speech acts:

(142) $\{ \text{Assert: } x \text{ ate } y \text{ and ate nothing else} \mid x, y \in D_e \}$

The assumption is that with the right pragmatic theory, (140) will come out meaning something along the lines of “What Fred ate was the beans, and there are other assertions that would be relevant for me to make concerning what other people ate”. There are various ways that the pragmatic side of the model could be spelled out in more detail, and I refer the reader to Tomioka (2010b: §3.4) for further discussion. My purpose here is not to argue about the merits of competing pragmatic implementations, but rather to discuss a few broad consequences of Tomioka’s analysis in the syntax, semantics and phonology—consequences that hold regardless of how the pragmatic issues are resolved.

⁷⁷For the details of how focus composition works under this framework, see Wold (1996).

⁷⁸Given the semantics in (141), it isn’t actually clear how an LF like (140) results in any primary assertion being made. I assume that the CT operator would need to be modified to say that, in addition to requiring that the set in (141a) be salient, the speech act $\llbracket \alpha \rrbracket^g$ is being performed.

The first large divergence in predictions between Tomioka’s account and the topic abstraction account stems from the fact that one system interprets CT in situ, and the other system via movement.⁷⁹ In fact, Tomioka (2010a: fn. 7) briefly considers the LF movement approach to CT, but sets it aside after mentioning two potential challenges it faces. The first challenge is that CT-marked quantifiers can take narrow scope, as we saw in section §3.2. As Tomioka points out, this isn’t a problem if we assume that the trace left by movement is of the same type as the moving constituent. In fact, we’ll see in chapter §4 that the type of the trace doesn’t need to be stipulated. The right type configuration is already implied by the semantics of topic abstraction.

The second challenge is that CT can mark verbs and adjectives, which “would seem to necessitate movement of an X-category to an XP adjunction position” (Tomioka 2010a: fn. 7). However here again, Tomioka already points to a solution: using pied-piping to raise a larger constituent. In fact, we see evidence for this kind of pied-piping in overt topicalization structures (e.g. “The books that *Chomsky* writes, I like”) and in the distribution of CT *-wa*, which occurs at the edge of a movable constituent, and never lower (cf. the island effects from Hara 2006, discussed in section §3.1.4).

While the LF movement approach doesn’t necessarily demand that every CT phrase itself be movable, it does provide a way of understanding island effects when they arise. As we saw in section §3.4, the topic abstraction account predicts that CT and Exh will never co-occur within an island—a constraint which found initial support in English. We also saw that such an account makes it easy to formulate restrictions on the distribution of CT particles and boundary tones (e.g. Japanese *-wa*, Mandarin *-ne*, English L-H%), which were shown to respect islands boundaries. On an in-situ theory of CT interpretation, it’s not clear how to explain either the

⁷⁹The decision to interpret CT (and focus generally) in situ doesn’t seem to be integral to Tomioka’s approach. As far as I can tell, the basic analysis of CT+Exh as a multiple focus construction where the CT operator out-scopes the Exh operator could equally well be formalized in a framework where focus association happens by movement.

island sensitivity of CT particles and boundary tones or the limited island sensitivity of CT phrases. In short, all the island-related challenges for Büring’s model discussed in §3.1.4 are equally challenging for Tomioka’s in-situ account.

The nested CT data from sections §3.1.5 and §3.5 are another problem. If we index one CT operator to bind multiple CT phrases, as in (143), we derive a complex CT reading where the two CTs are treated as equals. For instance, composition of the LF in (143) would result in the set of alternative assertions in (144), where the two CT phrases have the same “scope”. Thus, this approach is unable to capture the ability of one CT to out-scope another, as observed in section §3.1.5.

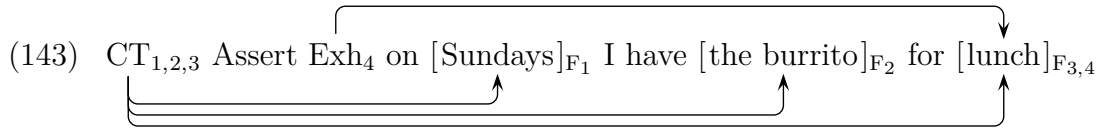

(144) { Assert: on x I have y for z , not for any other meal | $x, y, z \in D_e$ }

On the other hand, if we introduce a higher CT operator to bind the “higher” CT, the result is a nested set of speech acts (i.e. a set of sets of speech acts). The proposed LF and alternative set are illustrated in (145) and (146) below. Unlike nested questions denotations, which are hypothesized to play a role in the semantics of multiple wh- questions (Hagstrom 1998), it isn’t clear whether we would want to allow nested speech act alternatives into our ontology, or if we did, how they would be incorporated into the pragmatic system. Thus, at best, multiple CT data are a remaining puzzle for Tomioka’s (2010b) account.

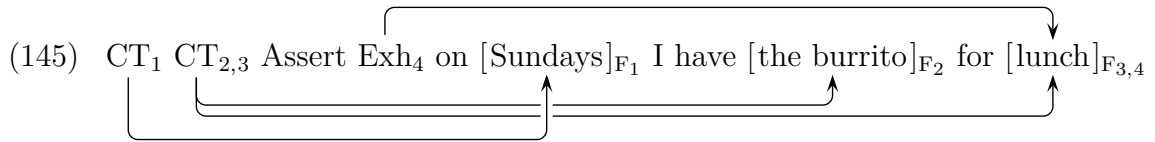

(146) $\{ \{ \text{Assert: on } x \text{ I have } y \text{ for } z, \text{ not for any other meal} \mid y, z \in D_e \} \mid x \in D_e \}$

One final challenge, for Tomioka’s account and all configurational accounts, is explaining how a particular focus binding configuration ends up getting spelled out with the characteristics of CT realization—that is, displaying the distinctive prosody, particles and/or word order that indicate CT meaning in a given language. To take a concrete example, how do we guarantee that English CT phrases will be pronounced with a CT contour (L+H* L-H%)? Under Tomioka’s proposal, this amounts to asking how we ensure that focus associates of the CT operator that aren’t bound by the Exh operator will get a specific prosodic realization. Short of outright stipulation, it’s not clear how this could be achieved. I’ll return to this issue in chapter §5, where I provide an explicit analysis of how the CT structures posited by the topic abstraction account are spelled out according to fairly general interface mechanics.

3.7.2 Comparison with Wagner 2012

Wagner (2012) provides a dedicated account of CT+Exh, and argues that Exh+CT and lone CT should be treated by other means, in terms of “rise-fall-rise” meaning. We already saw in section §3.6 that the main arguments against unifying these three constructions are less than fully decisive. In this section, I focus on Wagner’s formal treatment of CT+Exh and point out some differences between this analysis and the topic abstraction account.

Two features of Wagner’s account are already familiar to us. First, it shares with the topic abstraction account the feature that CTs are interpreted via LF movement. In fact, building on proposals by Krifka (2006) and Wagner (2006a), Wagner treats all focus association as association via movement. Second, Wagner’s account shares with

Tomioka's the view that CT+Exh constructions involve two focus-sensitive operators in a nested configuration.

The core of Wagner's proposal is that CT+Exh sentences involve two instances of a general-purpose focus operator, called FOCUS, which has an effect similar to Rooth's squiggle. These two FOCUS operators bind one focus each: the CT and Exh phrases. What distinguishes one phrase from the other is *which* operator they associate with. The phrase associating with the higher operator is interpreted as CT, while the associate of the lower operator is Exh. Putting all of this together, the sentence "[Fred]_{CT} ate [the beans]_{Exh}" will be represented as in (147), where arrows illustrate the LF movements of the two focused phrases. The effect of the FOCUS operators is encoded by the special interpretation rules in (148).

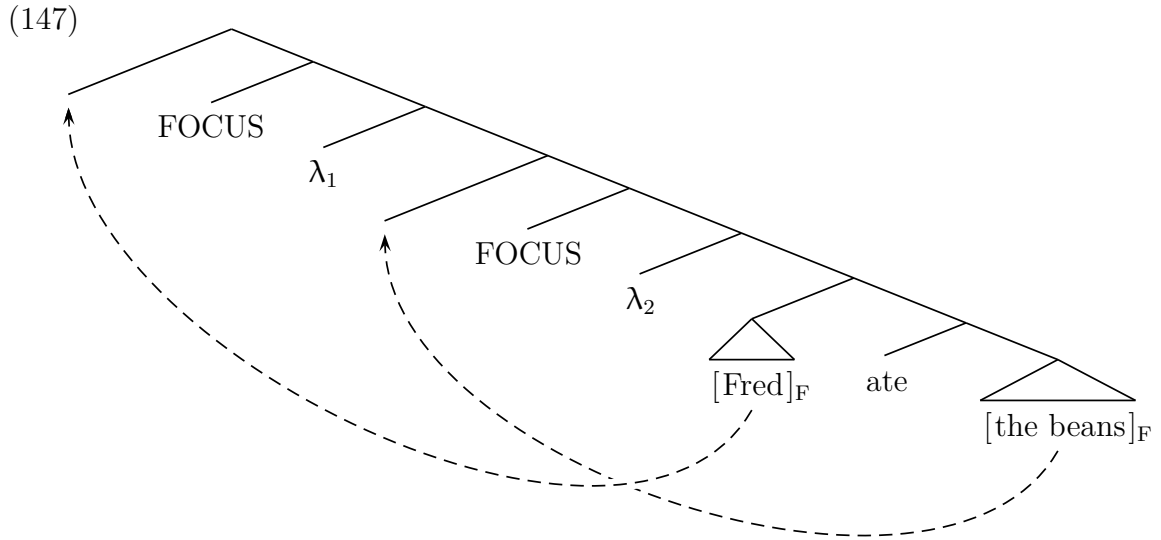

(148) **Wagner's FOCUS** (cf. Wagner 2012: 31)

- a. $\llbracket \psi [\text{FOCUS } \phi] \rrbracket^o = \llbracket \phi \rrbracket^o (\llbracket \psi \rrbracket^o)$
- b. $\llbracket \psi [\text{FOCUS } \phi] \rrbracket^f = \{ P(x) \mid P \in \llbracket \phi \rrbracket^f, x \in \llbracket \psi \rrbracket^f \}$
- c. ... and presupposes that the context contain an antecedent C such that:
 - i. $C \subseteq \{ P(x) \mid P \in \llbracket \phi \rrbracket^f, x \in \llbracket \psi \rrbracket^f \}$
 - ii. $|C| > 1$

I've taken the liberty of applying various cosmetic changes to Wagner's definition. These modest revisions make the parallel between Wagner's FOCUS and Rooth's squiggle more apparent, while I believe staying true to the spirit of the proposal. Wagner's actual implementation is based on an assumption that F-values can be constrained at the level of semantic composition to only contain *salient* alternatives. This is a departure from Rooth's framework, where F-values include any alternative of the right semantic type. My definition in (148) also makes it clear that the way FOCUS combines with its "arguments" must be stipulated as a non-compositional rule of interpretation—a point which is somewhat obscured by Wagner's discussion and notation.

The logical form of our CT+Exh example is repeated in (149). Composition of the focus and ordinary semantic values proceeds as in (150) and (151).⁸⁰ The '≐' symbols in (150a,c) are reminders that these steps depend crucially on being able to define predicate abstraction to "do what we want" in the focus dimension, which isn't trivial; see Shan (2004) and Novel and Romero (2010) for a description of the problem and a potential solution.

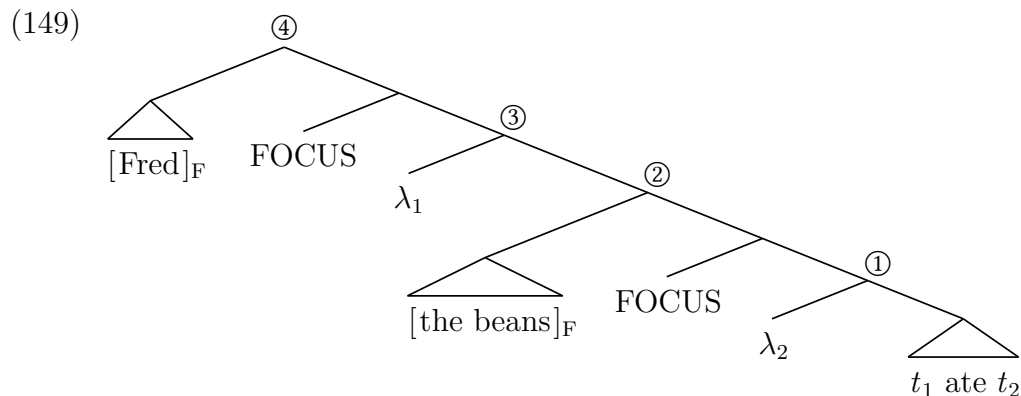

⁸⁰The semantic values in (150a,b) and (151a,b) are not meaningful objects on their own, since they contain an unbound variable x . I compute them because they're useful later in the derivation.

- (150) a. $\llbracket \textcircled{1} \rrbracket_{g[1 \rightarrow x]}^f \stackrel{?}{=} \{ \lambda y. x \text{ ate } y \}$
 b. $\llbracket \textcircled{2} \rrbracket_{g[1 \rightarrow x]}^f = \{ x \text{ ate } y \mid y \in D_e \}$
 c. $\llbracket \textcircled{3} \rrbracket^f \stackrel{?}{=} \{ \lambda x. x \text{ ate } y \mid y \in D_e \}$
 d. $\llbracket \textcircled{4} \rrbracket^f = \{ x \text{ ate } y \mid x, y \in D_e \}$
- (151) a. $\llbracket \textcircled{1} \rrbracket_{g[1 \rightarrow x]}^o = \lambda y. x \text{ ate } y$
 b. $\llbracket \textcircled{2} \rrbracket_{g[1 \rightarrow x]}^o = x \text{ ate the beans, presupposing } C \subseteq \{ x \text{ ate } y \mid y \in D_e \}$
 c. $\llbracket \textcircled{3} \rrbracket^o = \lambda x [x \text{ ate the beans, presupposing } C \subseteq \{ x \text{ ate } y \mid y \in D_e \}]$
 d. $\llbracket \textcircled{4} \rrbracket^o = \text{Fred ate the beans, presupposing } C_1 \subseteq \{ \text{Fred ate } x \mid x \in D_e \}$
 and $C_2 \subseteq \{ x \text{ ate } y \mid x, y \in D_e \}$

In (151), I write “presupposing $C \subseteq [\dots]$ ” as a shorthand for the condition in (148c) that the context contain an antecedent C that is a subset of a particular set, and contains two or more members. Crucially, each occurrence of the FOCUS operator introduces its own presupposition, and taken together, these two presuppositions roughly recreate the effect of Büring’s CT-congruence. Specifically, the sentence “[Fred]_{CT} ate [the beans]_{Exh}” is predicted to presuppose two question antecedents—one question about what Fred ate (among two or more alternatives), and one unsorted multiple question about what eater-eaten pairs there are. There are many interesting issues to be addressed concerning what the presupposition of these two questions really amounts to in terms of predictions about actual discourses. Without spelling out additional pragmatics assumptions, it’s not clear to what degree these predictions for CT+Exh licensing will differ from those of the other theories we’ve considered, so I will set this issue aside.⁸¹

⁸¹One potential difference is that on Wagner’s theory there is no mechanism directly ensuring that contrasting sub-questions will respect the “sortal key” established by the CT+Exh sub-answer. For example, at the level of semantics, there is nothing preventing a sub-answer sorting by people (e.g. [Fred]_{CT} ate [the beans]_{Exh}) from being directly followed by a sub-answer sorting by foods (e.g. [The pasta]_{CT}, [Mary]_{Exh} ate). To the degree that such “strategy shifts” are dispreferred, a theory like Wagner’s will have to provide an independent pragmatic explanation for the source of the

However, there are important differences regarding the range of examples predicted to license CT. First, let's look at what Wagner's model says about Exh+CT examples. In fact, all else being equal, the analysis of CT+Exh sentences described above would immediately extend to Exh+CT examples as well. Without additional stipulation, nothing would prevent, say, an object from associating with the higher FOCUS operator, while the subject associated with the lower one. Since Wagner holds that English Exh+CT demands a separate treatment, he stipulates that constructions with nested focus operators are restricted to only allow the surface scope reading.⁸² But importantly, the restriction against Exh+CT is imposed externally, and can be detached from the rest of the theory, if one wants to unify CT+Exh and Exh+CT.

By comparison, lone CT seems to be fundamentally incompatible with Wagner's formal notion of CT-hood. What defines a CT for Wagner is being the associate of the *higher* of two FOCUS operators. If a sentence only has one FOCUS operator, there is no way for us to distinguish between lone CT and lone Exh meanings. Of course, this isn't a concern for Wagner, since he aims to account for what I've called "lone CT" examples in separate terms. However, given the arguments for unification in section §3.6, it's worth highlighting that no simple variant of Wagner's analysis will be able to extend to lone CT.

How does Wagner's model handle the data that challenged Büring's account—CT questions, island sensitivity and multiple CT? While Wagner doesn't discuss these

problem. Conversely, to the degree that such shifts are acceptable, theories like Büring's, Tomioka's and mine will have to spell out the circumstances that allow the abandoning of a particular strategy or complex question.

⁸²Wagner offers some independent evidence for this surface scope restriction using overt focus operators like *even* and *only*, across several languages. However, while there is a clear tendency in this direction, a hard constraint seems too restrictive. As Wagner notes in an earlier (2008) draft of the 2012 paper, inverse scope of *even* and *only* is possible in English, as in his example "Even the LEAST poisonous snake ... would frighten only my truly pathetic roommate Bill JOHNSON", where *only* is naturally interpreted as having scope over *even*.

cases, it turns out that two of the three challenges can be addressed without much trouble. The problematic case is CT questions. Since the CT questions we looked at in sections §3.1.3 and §3.3 only have one focused element, the nested FOCUS configuration that Wagner treats as definitional of CT is absent.

Turning to the island facts, since Wagner’s account requires the CT phrase to undergo LF movement, it makes it easy to capture the island sensitivity discussed in sections §3.1.4 and §3.4. Like the topic abstraction account, Wagner’s model will permit CT island-internally only if we allow covert pied-piping. Furthermore, the account automatically captures the inability of CT and Exh to occur together in the same island, since the two phrases have to move to different FOCUS operator positions (hence, at least one would have to escape the island).

However, while LF movement gives us a way of handling island data, it doesn’t yet account for the existence of a dedicated syntactic position for CT phrases. For Wagner, the movements of the Exh and CT phrases are indistinguishable in the eyes of the syntax. They are both simply movement of an F-marked phrase to a FOCUS operator position. Thus, there is no direct expectation that the higher FOCUS operator will occupy a specific position in the left periphery, or that we would find dedicated particles spelled out at this position.⁸³

As for multiple CT data, Wagner’s account can plausibly be extended to capture the ability of one CT to out-scope another. If we raise three focused phrases to three distinct FOCUS positions, the operators will require the salience of three questions in the context—corresponding to the sub-sub-question, sub-question, and overall ques-

⁸³Wagner (2012: 34) does consider an alternative proposal on which the higher FOCUS operator is replaced by a dedicated CT operator. This alternative, while less parsimonious, has the potential to ground claims that CTs move to a fixed location, and provides us with a spot to hang CT particles. In fact, even on Wagner’s official proposal, it would be possible to explain why overtly raised CTs occupy a higher position than overtly raised Exh phrases (in languages that can raise both), since the CT associates with the higher FOCUS operator. However it would be surprising on the official account that a higher FOCUS can host CT particles while a lower FOCUS cannot.

tion being addressed. For example, the LF in (152) will presuppose the existence of the three question antecedent shown in (153). As with simple CT+Exh cases, this is a slightly weaker type of congruence than what is required by the topic abstraction account (which presupposes a single sorted question), which is in turn weaker than Büring’s CT-congruence (requiring the CT-marked utterance to be an answer to a sub-question within a strategy). However, again, it’s not clear that the weaker condition is insufficient, so I won’t dwell on this difference. The important point is that raising the CT *on Sundays* to the highest FOCUS position results in congruence to the complex question in (b) asking for all of Sunday’s food-meal pairings, and thereby implying a sorting of days over foods. Thus, the account provides a means of distinguishing two CTs by their relative scope.

- (152) [on [Sundays]_F] FOCUS λ_1
 [the burrito]_F FOCUS λ_2
 [for [lunch]_F] FOCUS λ_3 I have t_2 t_3 t_1

- (153) a. $C_1 \subseteq \{ \text{I have the burrito for } x \text{ on Sundays} \mid x \in D_e \}$
 b. $C_2 \subseteq \{ \text{I have } x \text{ for } y \text{ on Sundays} \mid x, y \in D_e \}$
 c. $C_3 \subseteq \{ \text{I have } x \text{ for } y \text{ on } z \mid x, y, z \in D_e \}$

Finally, as with Tomioka’s theory, and all configurational theories, there is a deep puzzle concerning the interface mechanics that control how CT structures come to *sound* like CT utterances. That is, how do the structures we’ve discussed above get translated into realizations with specific prosody, word order, or particles? For example, under Wagner’s theory, what interface mechanism is responsible for ensuring that an English phrase undergoing LF movement to the higher of two FOCUS operator positions will get realized with CT prosody?⁸⁴ Or how would we ensure that the

⁸⁴If we adopt the analysis of multiple CT in (152), the interface mechanism would apparently have to ensure that all *non-lowest* associates of FOCUS are pronounced with CT prosody.

associate of the higher FOCUS operator is marked by a dedicated particle like CT *-wa* in Japanese? We'll return to these questions, both for Wagner's account, and in the general case, in chapter §5.

3.7.3 Side-by-Side Comparison

At this point, we've looked at four theories of what CT conveys and how this meaning is built in the semantics. To wrap up our comparison, I've listed in (154) the major empirical generalizations that we've seen to distinguish these theories. Figure 3.2 provides a summary of which generalizations are captured by which theories.

- (154) Does the account capture the fact that...
- a. **CT Questions:** questions with CT marking are sub-questions, within a strategy of contrasting questions that vary in the CT position?
 - b. **Island Sensitivity:** the distribution of CT particles and tones is restricted by island boundaries, and CT and Exh can't co-occupy an island?
 - c. **Nested CT:** examples with multiple CT phrases can (but don't always) impose complex licensing conditions sensitive to the order of the CTs?
 - d. **Lone CT:** we find CT realizations in sentences without an Exh phrase?
 - e. **Exh+CT:** we find CT realizations in sentences where Exh precedes CT?
 - f. **CT Position:** there is a dedicated left-peripheral position that CT phrases often occupy cross-linguistically?

	Büiring 2003	Tomioka 2010b	Wagner 2012	Constant 2014
CT Questions	✗	✓	✗	✓
Island Sensitivity	✗	✗	✓	✓
Nested CT	✗	✗	✓	✓
Lone CT	✓	✓	✗	✓
Exh+CT	✓	✓	✗	✓
CT Position	✗	✗	✗	✓

Figure 3.2: Empirical coverage of four theories of CT

CHAPTER 4

CT-MARKED QUANTIFIERS

This chapter provides a semantic account of contrastive topic marked quantifiers.¹ We begin by observing a puzzle for standard theories (like Büring 1997b) that interpret CT-marked quantifier phrases as having generalized quantifier (GQ) type. The solution to this puzzle, following Rooth (2005), is to allow these phrases to have type-e denotations. In particular, I propose that CT-marked quantifier phrases are always type e, except in a highly constrained set of discourses that “sort by proportions”. As a consequence, we can leverage CT as a diagnostic for the semantic type of quantificational expressions. The results of applying this diagnostic are partially in line with standard theories of the split between “referential” and “quantificational” expressions (Fodor and Sag 1982, Reinhart 1997). However we will see that a range of quantifiers that are traditionally assumed to only allow quantificational readings (e.g. *most*, *more than three*) are nevertheless acceptable as contrastive topics. I argue based on corroborating diagnostics that this is not an accident. These quantifiers need to support referential meanings. Finally, using our knowledge of which semantic types are available to which quantifier phrases, we can turn to the question of how CT-marking interacts with quantifier scope. Once we factor out the referential expressions (which can be viewed as scopeless), the generalization that emerges is that CT-marked quantifiers always take narrow scope. This restriction is captured automatically on the topic abstraction account.

¹An earlier version of the account appears in Constant 2012c. This chapter presents the same basic analysis, but in a greater level of detail.

Before we take up the main line of argument, it will be useful to briefly review the classic distinction between quantificational and referential nominal expressions.

4.1 Referential vs. Quantificational Understandings

It is widely observed that a class of nominal expressions—roughly, indefinites—can be understood in two different ways. Here I borrow Fodor and Sag’s (1982) term UNDERSTANDING as a way of staying temporarily agnostic as to whether the difference maps onto a semantic ambiguity or not. Simple indefinites like ‘a cat’ provide the clearest examples. On the one hand, we can understand an indefinite as contributing existential quantification, as is easily the case in (1a)—for each kid, there exists some computer she used. On the other hand, we have indefinites like ‘a friend of mine’ in (1b) that seem more likely to refer to a particular individual, plausibly one that the speaker has in mind. I’m thinking of someone, and the kids all played with *her*.

- (1) a. Every kid had used **a computer** during the vacation.
- b. Every kid had played with **a friend of mine** during recess.

In broad terms, there have been two approaches to accounting for these different understandings of quantificational expressions like indefinites. The first approach posits a uniform semantic type for indefinites, and derives the different understandings via one or another scoping mechanism (e.g. quantifier raising), or via pragmatic means (e.g. a difference in verification strategy, or a difference in contextual domain restriction). Within this camp, some maintain a uniform GQ type for indefinites, including Montague (1973), Szabolcsi (1997), Geurts (2000, 2010), and Schwarzschild (2002), while others maintain a uniform referential type (Kamp 1981, Heim 1982, Abusch 1994). The second approach, including Fodor and Sag (1982), Reinhart (1997), Kratzer (1998), and Matthewson (1999), posits a semantic ambiguity local to the indefinite. On this view, some indefinites denote GQs and truly

quantify, while others denote individuals directly, and are thus understood referentially without recourse to any scoping mechanism or pragmatic enrichment.²

Debate on this issue is ongoing, and much of it revolves around accounting for the (un-)availabilities of wide-scope and intermediate scope readings across different structures; see Schwarz 2011 for review. Rather than rehashing the arguments from scope, I would like to make two novel contributions. First, I will offer some new evidence in support of the claim that we need to allow the option of referential type-e readings for some (seemingly) quantificational expressions. Second, I want to address a question that has received somewhat less attention: the question of exactly which quantifiers support referential understandings. Note that this question demands an answer regardless of the particular mechanism by which referential understandings are reached. On the approach that I will argue for, where CT-marked quantificational phrases may (and typically do) denote type e, the question boils down to which quantifiers allow type-e readings. We turn now to the evidence from CT for type-e readings.

4.2 The Problem for GQ Accounts

Most modern compositional analyses of contrastive topic have been developed within Rooth's (1985) alternative-based semantics for focus (among others, Büring 1997b, 2003; Wagner 2009, 2012; Tomioka 2010b; the present work). This is quite natural, as it is intuitively clear that interpreting a sentence with CT involves considering alternative values in the position of the CT phrase.

At the heart of Rooth's interpretation system is the idea that a focused phrase generates alternatives of the same semantic type as the phrase itself (see Rooth 1985:

²Winter's (1997) account shares with this second class of approaches the idea that indefinites get widest-scope construals via a different mechanism than other quantifier phrases, but does without a semantic ambiguity in the indefinite itself, holding onto a uniform GQ type.

56). Individual-denoting expressions give rise to individual-denoting alternatives, properties generate property alternatives, and so on. However, this fundamental principle of Rooth’s framework runs us into trouble when we look at CT-marked quantifiers.

Prominent theories of contrastive topic have either treated nominals containing CT-marked quantifiers as having standard GQ semantics, as in Büring 1997b, or else don’t take a stand on the issue (e.g. Büring 2003, Tomioka 2010b, Wagner 2012). However, Rooth (2005) observes that the GQ account as laid out by Büring (1997b) is not sufficient. The basic problem is that if a quantificational phrase like ‘some cat’ is interpreted as a generalized quantifier of type $\langle\langle e,t \rangle, t \rangle$, then we should expect that when such a phrase contains CT marking, the contrasting alternatives will be elements of the same type, namely other generalized quantifiers. However what we find in the vast majority of cases is that quantifiers marked as contrastive topics set up contrasts with individuals, not with GQ meanings.

I discuss four manifestations of this basic problem, two already mentioned by Rooth and two additional ones. For the sake of illustration, I limit the discussion to Büring’s (2003) implementation of CT meaning, although the problem extends both to earlier accounts like Büring 1997b, and to more recent theories like Tomioka 2010b, Wagner 2012, and the topic abstraction account from chapter §3. To be clear, the problem to be discussed is not with these theories themselves, but with the predictions the theories make if we assume (with Büring 1997b) that when *some* and *most* are CT-marked their interpretations are as traditional quantifiers of type $\langle\langle e,t \rangle, \langle\langle e,t \rangle, t \rangle \rangle$.

Recall from chapter §2 Büring’s (2003) prediction that an utterance with CT is always a partial answer, in the sense of answering just one among a set of two or more salient questions making up a larger issue in the discourse—in Roberts’ (1996) terms, this set of questions is a DISCOURSE STRATEGY. Furthermore, the form of the discourse strategy is constrained by the placement of CT- and F- marking on

‘SOME grads’ is contrasting not with GQ-denoting alternatives like ‘many grads’, but rather with individual-denoting alternatives like ‘the other grads’.

(4) A: Where do the grads live?

B: $[\text{SOME}]_{\text{CT}}$ grads ... live $[\text{in AMHERST}]_{\text{Exh}}$.
 $L+H^*$ $L-H\%$ H^* $L-L\%$

(5) $[(4)]^{\text{ct}} = \{ \text{Where do some grads live? Where do many grads live? ...} \}$

Beyond the intuitive implausibility of contrasting quantifier denotations, Rooth also observes a problem in terms of the implicatures predicted. In general, when contrastive topic marks the answer to a sub-question (even an implicit one), a conversational implicature is generated to the effect that the marked utterance is a *complete* answer to that sub-question. For example, (6) implicates that Manny is the only person who Anna danced with. By the same token, if (4) answers the implicit question “Where do some grads live?”, we predict an implicature that Amherst is the only place that has some grads living there. However there seems to be no implicature of this sort.

(6) A: Who danced with who?

B: $[\text{ANNA}]_{\text{CT}}$... danced with $[\text{MANNY}]_{\text{Exh}}$. (Rooth 2005: ex. 32)

Beyond the problems Rooth mentions, I would like to raise two additional obstacles to treating CT quantifiers in terms of contrasting GQ meanings. First, as (7) shows, we have the possibility of contrasting two instances of the same quantifier. The problem here is that, according to Büring’s CT-congruence condition, each of B’s responses should mark a contrast between the sub-question being answered (Where do some grads live?) and some *other* question in the discourse, where *some* is replaced with a differing alternative of type $\langle\langle e,t \rangle, \langle\langle e,t \rangle, t \rangle\rangle$ like *most* or *few*. However, in this dialogue, no additional sub-questions are implied. That is, B’s two responses may exhaust the grad students in question—so none of them live anywhere but these two towns.

In this case, each occurrence of *some* simply contrasts with the other, rather than contrasting with some implicit differing quantifier.

(7) A: Where do the grads live?

B: [SOME]_{CT} of them ... live [in AMHERST]_{Exh}.

And [SOME]_{CT} of them ... live [in NORTHAMPTON]_{Exh}.

Finally, we reach perhaps the most striking puzzle for the GQ account. If sentences like (4) are interpreted by generating traditional quantifier alternatives to *some*, then we should equally well be able to generate alternatives to a quantifier like *few*. However *few* in fact strongly resists CT-marking, as in (8). Furthermore, (9) shows that it is nothing more than the intonational pattern ruling the sentence out. If the CT and Exh accents are reversed, the sentence is acceptable, and marks a strategy of questions of the form “For each place, how many of the grads live there?”⁵

(8) A: Where do the grads live?

B: # [FEW]_{CT} of them ... live [in AMHERST]_{Exh}.
 L+H* L-H% H* L-L%

(9) A: Where do the grads live?

B: [FEW]_{Exh} of them live [in AMHERST]_{CT} ...
 H* L- L+H* L-H%

What’s more, the failure of *few* as a contrastive topic isn’t idiosyncratic to one single lexical item. Other quantifiers that are downward entailing on their nuclear scope, including *less than three* and *hardly any*, equally resist CT-marking in a frame like (8).⁶

⁵The dialogue in (9) is more natural if the decision to sort by places instead of people is made explicit—for example, if A’s question is followed up with “Do any live in AMHERST?”. Note that this modification does not save (8).

⁶A determiner is downward entailing on its nuclear scope—also known as “(right) monotone decreasing”—just in case $[A \subseteq B \wedge Det(X)(A)] \rightarrow Det(X)(B)$. As Szabolcsi (2010: 56) notes, the

4.3 The Type-e Solution

The solution Rooth (2005) puts forward is to treat the problematic CT-marked phrases like ‘SOME cat(s)’ as denoting individuals (or groups thereof), rather than generalized quantifiers. That is, these phrases denote type e rather than type $\langle\langle e,t\rangle,t\rangle$. Rooth’s implementation of this proposal is in the spirit of Reinhart (1997), whereby some (seemingly) quantificational expressions can in fact refer directly by means of a choice functional semantics. Rooth suggests that *some* denotes a choice function variable—a function of type $\langle\langle e,t\rangle,e\rangle$ that given a property as input, returns some individual who has that property. Thus, ‘some cat’ and ‘some cats’ are of type e , and denote a particular cat and a particular plurality of cats respectively. When we adopt this analysis, the alternatives generated by ‘[SOME]_{CT} cats’ are computed by substituting different choice functions in the position of the CT-marked *some*. Combining these with the restrictor *cats*, we produce contrasting pluralities of cats. For the details of this composition process, see section §4.8.

This approach immediately addresses our four concerns from above. If ‘some grads’ denotes a specific plural individual, then we expect (4) to answer an implicit question about where a particular group of grads lives. This seems to be exactly what (4) does, and this time the expected implicature that the answer resolves the subquestion goes through. Furthermore, since different instances of *some* can stand for different choice function variables, we have an explanation for why *some* and *some* are able to contrast in (7). Finally, from Reinhart (1997), we know that quantifiers like *few* lack choice-functional interpretations (more on this below). Thus, (8) only has the standard GQ reading, and if we maintain—as Rooth seems to—that CT is simply unable to contrast quantifiers of this type, then the sentence will be ruled out.

contribution of increasing quantifiers, but not decreasing quantifiers, can be formulated in terms of existential quantification over witness sets.

In a moment, we will see an important consequence of this account—it points to a new answer to the question of which quantifiers are compatible with choice functional interpretations. But first, let me address the issue of whether true GQs can ever be CT-marked. In most cases, it is accurate to say that *few* fails as a contrastive topic. This failure makes sense on the view that nominals with *few* are robustly GQ-denoting, given some reasonable assumptions about how we tend to structure discourse. Specifically, let’s say that for cognitive reasons, humans avoid breaking up a large issue into sub-issues sorted by proportions as opposed to individuals. That is, while it’s easy to ask a sub-question about an individual (And what about *Fred*? Where does *he* live?), it’s hard to treat proportions in the same way (And what about *few*? Where do *few* students live?). However this is not to say that such a discourse is impossible. The following context licenses a CT-marked use of *few*, precisely because we *are* contrasting different proportions:⁷

(10) Context: A is trying to figure out how hard each problem is on an exam she has written. As an experiment, she asks B to have his students take the exam, to see how they do. After B has graded the exams, A asks...

A: Okay, first tell me, which problems did *all* the students solve?

B: *All* the students solved problems one and six.

A: And which problems did *most* of them solve?

B: *Most* of them solved problems two and five.

A: And which problems did *few* of them solve?

B: [FEW]_{CT} of them ... solved [problems three and FOUR]_F.
 L+H* L-H% H* L-L%

⁷While I claim that there is a moderate cognitive difficulty in using a classical quantifier denotation as a contrastive topic, I do not wish to suggest that quantifier meanings resist being marked for contrast in general. In particular, we find no corresponding difficulty in using a quantifier as an exhaustive focus. For example, if I ask you how many students passed, you can answer “FEW of them passed.” Intuitively, posing a question that asks you to choose the correct proportion out of a set of proportions is natural, whereas posing a strategy of sub-questions where each question asks about a different proportion is unusual.

Unlike Rooth’s examples, in this case, we really are directly answering a sub-question containing a GQ, and in fact the sub-question appears explicitly in the discourse. Furthermore, in this case, the implicature of a complete answer is plausible. That is, B could reasonably be taken to imply that problems three and four are the only ones that few students solved.⁸

To wrap up our caveat, it is not true (as Rooth’s examples in isolation might suggest) that GQ denotations are fundamentally incompatible with CT meaning. Rather, CT-marking on a quantifier in a GQ-denoting phrase will require a discourse that “sorts by proportions”, and these are hard to come by.⁹ By “sorting by proportions”, I mean precisely that the discourse employs a strategy of questions that vary in a GQ-denoting position. The basic fact that we need to capture, then, is that CT-marked quantifiers like *some* do not necessarily set up proportional contrasts, and thus do not require this sort of unusual supporting context. The proposal on the table is that they are free of this requirement by virtue of having a referential, type-*e* interpretation. If this is right, we can hold onto a simple characterization of how CT interacts with type: CT-marking a phrase of type τ implies a discourse sorted by elements of type τ —implying a strategy of questions, each about a different type- τ alternative.

⁸The dialogue in (10) could naturally be followed with a question about which problems *no* students solved. In this case, B’s statement that “Few of them solved problems three and four” should be taken to mean that problems three and four were the only problems that few but more than no students solved. Alternatively, if the distinction between *few* and *none* is not relevant to the discourse, then B may be taken to mean that problems three and four were the only problems that either few or no students solved. Crucially, in either case, B’s answer is implicated to be fully resolving of the question it answers. A similar issue arises with *most* in (10), which must be taken to mean ‘most but not all’.

⁹A more mundane set of examples supporting proportions as CT is conditionals containing predicates that can hold of multiple individuals, as in “If FEW of them show up, it would be a DISASTER.” By contrast, if the predicate can only hold of a single individual, the proportion-as-CT reading is ruled out, as in “If { MOST | #FEW } people were president, they’d find it STRESSFUL.”

4.4 Which Quantifiers Allow Type-e Meanings?

In this section, I argue that a particular set of quantifiers, which I will call EXISTENCE-ENTAILING (EE) quantifiers are compatible with type-e readings, while other (non-EE) quantifiers only give rise to GQ readings. The evidence will come from contrastive topic, based on the behavior we have seen above. Supporting evidence from two other diagnostic constructions—equatives and supplements—is provided in the following sections §4.5 and §4.6.

For theories that posit a type ambiguity among quantificational expressions, there is an important question of exactly which quantifiers allow referential, or type-e meanings. In raising this question, Reinhart (1997: §6.4) suggests that the ideal answer would consist of a simple semantic characterization. However, after considering a particular semantic analysis of the split, Reinhart ends up rejecting it as incompatible with the facts. The semantic proposal she considers—building on work by Szabolcsi (1995, 1997)—is that the quantifiers compatible with type-e meanings are those that allow assessment by checking just one minimal witness set of the GQ.¹⁰ However Reinhart rejects this approach on the grounds that *more than three* and *most* fit this semantic characterization, but supposedly lack type-e readings (based primarily on their scopal behavior). Thus, Reinhart’s official proposal abandons the goal of deriving a quantifier’s potential for referentiality directly from its semantic properties. Nevertheless, the empirical description of the split among quantifiers as laid out by Reinhart (1997) and Winter (1997) has been widely influential. The commonly adopted claim is that the “simple indefinites” in (11a) allow exceptional wide-scope, and hence have referential readings, while the quantifiers in (11b) and (11c) do not, and hence only have GQ readings.

¹⁰A witness set is any set in the denotation of the GQ that is also a subset of its live-on set (Barwise and Cooper 1981).

- (11) a. some, a, three, several, many, a few (EE)
 b. most, all, more than 3, at least 3, exactly 3, half (EE)
 c. few, no, less than 3, not many (non-EE)

We've seen above that contrastive topic can be used as a diagnostic for type-e meaning. What we will find by applying this novel diagnostic is that a wider range of quantifiers permit referential readings than traditionally assumed. In particular, I claim that not only the quantifiers in (11a), but also those in (11b) have these readings. Before seeing the evidence from CT, one point in favor of this particular split is that it allows for a simple semantic characterization of the kind Reinhart had aimed for. The quantifiers in (11a,b) are what I will call EXISTENCE ENTAILING, meaning that they imply the existence of some individual satisfying both their restrictor and scope, as in (12).¹¹ In Nouwen's (2003) terms, these quantifiers imply the existence of an individual in their "reference set".

- (12) A determiner *Det* is EXISTENCE ENTAILING iff $Det(P)(Q) \rightarrow \exists x : P(x) \wedge Q(x)$

At this point, we can turn to the CT data. In the previous section, we considered the claim that quantifiers like *some* can be CT-marked in non-proportion-contrasting contexts precisely because they allow type-e interpretations. If this proposal is correct, then we expect all and only the quantifiers that admit referential interpretations to be compatible with CT marking in a context like (13) below. Happily, all the quantifiers that are commonly assumed to allow referential interpretations are licensed in this frame. Furthermore, many of the quantifiers that are generally assumed to lack these interpretations (e.g. *few*) are illicit, as expected. However remarkably, CT intonation

¹¹This definition does largely the same work as the semantic characterization Reinhart discusses (and rejects) in terms of assessment by checking a minimal witness. However while ruling in *most* and *more than three*, this definition would rule out quantifiers like *exactly three*, which is existence-entailing in my sense, but cannot be assessed by checking just one minimal witness set.

is licensed on a range of quantifiers that are widely viewed as lacking referential interpretations, including *most*, *half*, *more than N* and *exactly N*.¹²

(13) A: Where do the grads live?

B: [$\underline{\hspace{2cm}}$]_{CT} (of the) grads ... live [in AMHERST]_{Exh.}
 L+H^* L-H\% H^* L-L\%

$$\left\{ \begin{array}{l} \text{SOME | TEN | MANY | SEVERAL | A FEW} \\ \text{MOST | HALF | More than TEN | Exactly TEN} \\ \text{\#FEW | \#NONE | \#Not MANY | \#Less than TEN} \end{array} \right\}$$

The simplest explanation for these facts, and the one I pursue here, is to say that all the licit quantifiers in (13) can have referential interpretations (although this is not their only interpretation). This explanation goes against the traditional wisdom on the matter, which is largely grounded in facts about the scope-taking abilities of the different quantifiers, and specifically whether they can take exceptional wide scope out of islands. I will not address the scope facts here, but acknowledge that it is an important task to reconcile the conflicting results from these various diagnostics, and to better understand what each test is telling us. The following sections present two additional diagnostic constructions (equatives and supplements) that add support for the claim that it is precisely the set of EE quantifiers that allow type-e readings.

To wrap up the discussion of CT as a diagnostic for quantifier type, I'd like to present a few examples that attest to the range of cases in which the diagnostic can apply. First, we can observe that the diagnostic is robust across both the syntactic category of the quantifier in question, as well as the domain of elements being quantified over. In (14–15), we find that the pattern from above extends to adverbial

¹²The reader may note that *all* fails as a contrastive topic in (13), despite being existence-entailing (assuming that *all* presupposes a non-empty domain). This is not because ‘all of the grads’ fails to denote type e; we will see in the next section that it has this ability. Rather, *all* is unable to stand as CT in (13) because the CT-marked utterance would completely resolve the issue at hand, conflicting with the partial answer semantics of CT. See Büring (1997a) for more detailed discussion of this type of infelicity.

and adjectival quantifiers, in the temporal and modal domains. As with *few*, the quantifiers that resist CT are downward entailing, and plausibly non-EE:¹³

- (14) a. We [OFTEN | OCCASIONALLY | USUALLY]_{CT} ... [go DANCING]_{Exh}.
 b. #We [SELDOM | HARDLY EVER | RARELY]_{CT} ... [go DANCING]_{Exh}.
- (15) a. It's [LIKELY | PROBABLE | POSSIBLE]_{CT} ... that he'll [WIN]_{Exh}.
 b. #It's [UNLIKELY | IMPROBABLE | DOUBTFUL]_{CT} ... that he'll [WIN]_{Exh}.

The CT diagnostic is also flexible as to whether or not there is a co-occurring exhaustive focus. The following frame is a case of lone CT, as discussed in the previous chapters. Once again, the cut across quantifiers is the same:¹⁴

(16) A: Did you read all of the articles I gave you?

B: I read [_____]_{CT} of them...
 L+H* L-H%

$$\left\{ \begin{array}{l} \text{SOME | TEN | MANY | SEVERAL | a FEW} \\ \text{MOST | more than TEN | exactly TEN | HALF} \\ \text{\#FEW | \#NONE | \#not MANY | \#less than TEN} \end{array} \right\}$$

¹³If the adverbials in (14) quantify over times (following Kamp 1971 and Partee 1973) or situations (following Heim 1990 and von Stechow 1994), and the modals in (15) over possible worlds (building on Kripke 1959, 1963, and others) then we can imagine treatments of *often* and *likely* as EE, in the sense of entailing the existence of a time, situation, or world where the nuclear scope holds. The downward-entailing items *seldom* and *unlikely* on the other hand would be non-EE, since they don't entail the existence of any such time, situation, or world.

¹⁴Extra care needs to be taken with lone CT, since contexts supporting proportions as CT are more readily available. This may stem from the fact that lone CT strategies are conceptually relatively simple, requiring no more than a yes/no answer for each choice of CT. Thus, for example, if you complain that none of the workers are qualified, I could retort that “[FEW]_{CT} of them are qualified... (but not none!)”. The strategy here is the same that would be evoked in the full CT+Exh structure “[FEW]_{CT} of them ... [YES]_{Exh}. But [NONE]_{CT} of them ... [NO]_{Exh}.” We find parallel cases of lone CT on non-EE modal quantifiers, as in “It's [UNLIKELY]_{CT}... (but not impossible!)”.

4.5 Support from Equatives

This section presents new evidence from equatives that existence-entailing (EE) quantifier phrases like ‘most cats’ can denote type *e*, while non-EE phrases like ‘few cats’ cannot.

4.5.1 The Equative Diagnostic and How it Works

EQUATIVES are copular constructions that equate two individual-denoting expressions. In the following frame, if the object is able to denote a plurality, the sentence is a well-formed equation of two pluralities. On the other hand, if the object can only denote a GQ, then the sentence will be ill-formed, for reasons we will see shortly. Remarkably, this frame makes the same cut across quantifiers that we saw in the previous section.

(17) Those people standing over there are _____ of my best students.

$$\left\{ \begin{array}{l} \text{some | ten | many | several | a few} \\ \text{most | all | more than ten | exactly ten | half} \\ \text{*few | *none | *not many | ??less than ten} \end{array} \right\}$$

What goes wrong if the object in (17) denotes a GQ? There are a variety of answers, depending on how we go about trying to interpret the sentence compositionally. I discuss here four (non-)options for interpretation, each of which will result in either a degenerate meaning or a type mismatch. Of course, other mechanisms for interpreting these structures could be devised to sidestep these problems. But the point is that such mechanisms cannot exist, or else the infelicitous forms in (17) would be acceptable.

At the root of it, the problem is in how the object composes with the rest of the sentence. If the copula is taken to be inert, the GQ object can’t compose directly with the individual-denoting subject. On the other hand, if we treat *be* as a two-place predicate, this can’t combine with the GQ either. One standard approach to avoiding

this apparent type mismatch is to raise the GQ via quantifier raising (QR), leaving a type-e trace below. However, in our example, the property that would result from QR can never be satisfied by atomic individuals. Specifically, the property that would end up as the nuclear scope of *few* is the property of *being* those people standing over there. Since *few* quantifies over atoms, this property is never satisfiable, and the truth conditions are vacuous.

In (18), we see a more explicit rendering of the problem with QR. Given the type $\langle\langle e,t \rangle, \langle\langle e,t \rangle, t \rangle\rangle$ quantifier denotation for *few* in (18a), the GQ ‘few of my best students’ will be uninterpretable in object position, and will be forced to undergo QR to a position above the subject, as in (18b). However, the resulting truth conditions in (18c) are tautological, given that no atomic individual can be a plurality. By contrast, (19a) shows a choice-function-compatible property-modifying denotation for *most*. Since the meaning of ‘most of my best students’ can combine with the null choice function variable f_3 , the expression can be interpreted in situ as type e, as shown in (19b). The truth conditions in (19c) are reasonable, assuming some mechanism for binding of the choice function at the level of discourse.¹⁵

- (18) a. $\llbracket \text{few} \rrbracket = \lambda P_{\langle e,t \rangle} \lambda Q_{\langle e,t \rangle}$
 $|\{x : \text{atom}(x) \wedge P(x) \wedge Q(x)\}| \ll |\{x : \text{atom}(x) \wedge P(x)\}|$
- b. $[\text{few of my best students}]_{\text{DP}} [\lambda_3 [\text{those people}]_{\text{DP}} \text{ are } t_3]_{\text{IP}}$
- c. $|\{x : \text{atom}(x) \wedge \text{best}(x) \wedge \text{is-those-people}(x)\}| \ll |\{x : \text{atom}(x) \wedge \text{best}(x)\}|$
 “Among the atomic individuals that have the property of being one of my best students, few have the property of being those people over there.”

¹⁵There are various approaches here, and the data so far don’t provide evidence for one over another. For Reinhart (1997) and Winter (1997), the choice function variable is bound existentially. For Kratzer (1998, 2003), choice function variables receive their value directly from the context of utterance (though a speaker need not know which choice function she is referring to). In the next section, we will see one argument in favor of Kratzer’s approach.

- (19) a. $\llbracket \text{most} \rrbracket = \lambda P_{\langle e,t \rangle} \lambda x_e \left[P(x) \wedge |\text{Atoms}(x)| > \frac{1}{2} \times |\{y : \text{atom}(y) \wedge P(y)\}| \right]$
- b. $[\text{those people}]_{\text{DP}}$ are $[f_3 \text{ most of my best students}]_{\text{DP}}$
- c. The unique x_e s.t. x is “those people standing over there”
 $= f_3 \left(\lambda x_e \left[\text{best}(x) \wedge |\text{Atoms}(x)| > \frac{1}{2} \times |\{y : \text{atom}(y) \wedge \text{best}(y)\}| \right] \right)$
 “The plurality picked out by ‘those people standing over there’ is the same as the plurality returned by the choice function f_3 when applied to the property of being a majority of my best students.”

Given the problem for QR, how else might we resolve the type conflict? With the technology of Partee (1987), three type-shifting approaches present themselves. First, we could shift the subject from an individual to a property with Partee’s ‘ident’ operation, as in (20a). Second, we could shift the GQ to a property with Montague’s (1973) BE operator in (20b). Finally, we could shift the GQ to an individual with Partee’s ‘lower’ in (20c).

- (20) a. $x_e \rightarrow \lambda y [y = x]$ (Partee’s ‘ident’)
- b. $GQ_{\langle\langle e,t \rangle, t \rangle} \rightarrow \lambda x [GQ (\lambda y [y = x])]$ (Montague’s BE)
- c. $GQ_{\langle\langle e,t \rangle, t \rangle} \rightarrow$ the generator of principal ultrafilter GQ ¹⁶ (Partee’s ‘lower’)

But while these type shifts offer another way around the type conflict, they don’t get us any closer to a reasonable semantics for (17). The first two type-shifting approaches suffer the same problem as QR. We end up requiring that few individuals have the property of being equal to a group. With lowering, the problem is simpler: the shift itself doesn’t go through. Standard GQ meanings like ‘few cats’ are not lowerable, since they are not principal ultrafilters. To be lowerable, a GQ has to be degenerate in the sense of containing all and only the properties that a single individual has—in Winter’s (1997) terms, the GQ “corresponds” to a particular individual.¹⁷ In sum,

¹⁶The generator of principal ultrafilter GQ is the unique x such that for some set S : GQ is the set of all supersets of $\{x\}$ in S .

our attempts at interpreting an object GQ in (17) have failed. The claim then is that a GQ is indeed uninterpretable in this frame, and that this is the source of the infelicity observed.

4.5.2 Features of the Equative Diagnostic

The success of the frame above in getting at the contrast we’re looking for derives from a few carefully-selected attributes. It’s worth drawing these out to see why other frames fail to make the same slice. First, one may ask what goes wrong if we position the quantificational phrase as the subject instead of the object. That is, if ‘most of my best students’ can indeed denote a plurality, what’s wrong with the following equation of pluralities?

(21) ??Most of my best students are those people standing over there.

I suspect that the problem here is at least partly information-structural. Given that subjects are canonically topics, (17) can serve as a natural answer to the question “Who are those people standing over there?”. By comparison, if the subject in (21) is topical, it would imply the much less natural question “Who are most of my best students?”. Importantly, whatever is wrong with (21) can’t be pinned on a general inability of ‘most of my best students’ to denote a plurality. If this were the source of the problem, we would expect an improvement by switching to an uncontroversially CF-supporting quantifier, but in fact, these are just as bad:

¹⁷We could consider redefining ‘lower’ to map a principal *filter* GQ onto its generator set (the unique G such that for some set S : GQ is the set of all supersets of G in S). On Landman’s (1989) or Schwarzschild’s (1996) approach to plurals, this generator set would directly represent a type-e plurality. (If we followed Link (1983), we’d just define ‘lower’ to map a principal filter onto the *mereological sum* of the elements in its generator set.) But even with this extension, a phrase like ‘few cats’ will not be lowerable unless it is allowed to denote a degenerate GQ that already corresponds to a *particular* few, presumably by some choice-functional mechanism.

(22) ??{ Many | Several } of my best students are those people standing over there.

A second feature of the successful equative frame is that the quantifier phrase is partitive. This is crucial to making the cut in question, as we see from the example below, where the object is non-partitive. The judgment marks in (23) reflect my own intuitions, but the precise relative felicities are not important for the present purposes. What is important is that something makes a wide variety of quantifiers unnatural in this context, and that the unnaturalness does not merely hold of those quantifiers that traditionally lack CF readings, but also extends to traditionally CF-compatible quantifiers like *many*. Thus, infelicity in this frame cannot be taken to demonstrate anything about the semantic type of the quantifier phrase.¹⁸

(23) Those people standing over there are [_____ students]_{DP}.

$$\left\{ \begin{array}{l} \text{some | ten | ??many | ?several | ?a few} \\ \text{??most | ??all | ?more than ten | ?exactly ten} \\ \text{*few | *no | *not many | ??less than ten} \end{array} \right\}$$

A third feature of our successful equative frame is that the subject ‘those people standing over there’ is individual-denoting. This is not something we can take for granted of definite descriptions or even pronouns. In the examples in (24), which appear to contradict our core finding from section §4.4, I claim that the subjects denote properties—type $\langle e, t \rangle$ —following Mikkelsen (2004), and that this is what allows them to compose with GQ-denoting objects. These sentences don’t constitute a challenge to the reasoning behind the equative diagnostic, since they aren’t equatives in the first place.

¹⁸A skeptic might at this point contend that the equative diagnostic has only shown that particular quantificational DPs *containing partitives* can denote type e , and has shown nothing about the type options available to ‘most students’. In response, we could turn to a non-partitive example like “Those people standing over there are _____ contestants qualified to compete”, which appears to draw the same split (ignoring *half*, which requires the partitive), although the judgments are less clear. But ideally we would like to understand exactly why partitives lend support to the type- e readings. I will have to leave this problem to future work.

- (24) (Who were the winners of last night’s elections?)
- a. The winners were { few | none } of the people I would have expected.
 - b. They were { few | none | not many } of the people I would have expected.

The claim that the subjects in (24) denote properties is not far-fetched, given that definite descriptions like ‘the winner’ and pronouns like *it* and *that* are often taken to denote properties in specificational clauses like (25), as on Mikkelsen’s (2004) analysis. In fact, Mikkelsen (2004: §5.2.3) makes use of copular questions asking who instantiates a property as a way of ensuring that an object-focused answer has a property-denoting subject, and this is precisely the type of context in which (24) is most natural.

- (25) A: Who is the winner?
 B: { The winner | It | That } is Susan.

Perhaps the clearest way to distinguish specificational readings (where the subject is a property) from predicative and equative readings (where the subject is an individual) is by looking at how the subject pronominalizes in tag questions, as in (26), from Mikkelsen (2004: 106). While individual-denoting subjects are resumed by gendered pronouns, property-denoting subjects license neuter pronouns.

- (26) a. The tallest girl in the class is Swedish, isn’t **she**? PREDICATIONAL
 b. *<pointing>* SHE is Molly Jacobson, isn’t **she**? EQUATIVE
 c. The tallest girl in the class is Molly, isn’t **it**? SPECIFICATIONAL

It is an inconvenient fact of English, however, that when we turn to plural subjects, this distinction is neutralized. By analogy with (26), we can reasonably assume that *they* in (27ab) refers back to individual pluralities, while in (27c) the same pronoun refers back to the property of being the tallest girls in the class. If this is right, then *they* is not robustly individual-denoting, contra Mikkelsen’s (2004: 168) assumptions;

rather, *they* can serve as an anaphor to properties of pluralities.¹⁹ In this case, we cannot use tag questions to directly reveal the semantic type of plural subjects.

- (27) a. The tallest girls in the class are Swedish, aren't **they**?
b. *<pointing>* THEY are Molly and Ana, aren't **they**?
c. The tallest girls in the class are Molly and Ana, aren't **they**?

We can however leverage the analogy with singulars to provide indirect evidence as to the types of plural subjects. For example, (28) is a minimal pair with (24) that switches the subject to a singular, and switches the quantifier to *one*. The pronoun reveals that this subject is indeed property-denoting, and thus we can infer the same of (24).

- (28) The winner was one of the people you expected, wasn't {it | ??she}?

In this light, we can return to our original diagnostic for quantifier phrase type, repeated in condensed form in (29). (I've switched to a gendered noun to make the anaphora judgments clearer.) When we construct a minimal pair in the singular, as in (30), we find that the subject here is robustly individual-denoting. Thus, we are justified both in using (29) as an equative frame to rule out GQ objects, and in disregarding (24) for the same purpose.

¹⁹As additional confirmation, observe that I can answer the question "Who are the most annoying girls in the class?" with "**They**'re Molly and Anna." By Mikkelsen's (2004: §5.2.3) question-answer pair diagnostic, this response must be specificational.

(29) Those girls standing over there are {some | most | *few } of my best students.

(30) That girl standing over there is one of your best students, isn't {she | ??it }?

One final point about the equative frame is that for the logic behind the diagnostic to go through, the quantificational phrase itself should not be able to denote a property or quantify over properties. Consider (31), in which the object is not equated with the subject, but instead is predicated of it.²⁰ Here, there is no requirement that the object denote type *e*, and non-EE quantifiers are licensed.

(31) They say we are rebellious, impulsive, idealistic, irresponsible, inexperienced.
In fact, we are {none | few | some | many | most | all } of these things.

To confirm that a copular sentence has or lacks a predicational reading, we can use Mikkelsen's (2004: 164) small clause diagnostic. The fact that (31) can be paraphrased with a small clause structure, as in (32), is evidence that it is indeed predicational. When we run the same test on our original equative frame, as in (33) we get the opposite result.²¹ This confirms that the frame is indeed equative as advertised.

²⁰I do not resolve here whether 'few of these things' is interpreted as a complex property, or whether quantification over simplex properties is called for.

²¹The judgments are less clear with *some*, as in "I consider those people standing over there some of my best students." However the important point is just that the quantifiers at issue here (*most*, *half*, *all*, *more than three*, and so on) are incompatible with the predicational structure.

(32) I consider them {none | few | some | many | most | all} of these things.

(33) I consider those people standing over there *(to be)
{most | more than three | half | all} of my best students.

4.6 Support from Supplements

In this section, we find that all and only existence-entailing (EE) quantifier phrases can stand as anchors to various types of supplementing material—nominal appositions, non-restrictive relative clauses, and modifiers with *including*. Given that only type-e expressions can anchor supplements, as has been argued previously, the distribution of supplements provides new evidence that all and only EE quantifier phrases can denote type e.

4.6.1 Background on Supplements

Supplementing expressions add parenthetical information that is secondary to the main claim being made. The bolded elements in the following example from Potts (2005: 13) show two kinds of supplements to nominals—a NOMINAL APPPOSITION and a SUPPLEMENTARY RELATIVE. Following Potts, I will use the term ANCHOR to refer to the phrase that the supplement attaches to and adds information about.

- (34) a. Ames, **the former spy**, is now behind bars. (Nominal Apposition)
b. Ames, **who stole from the FBI**, is now behind bars.
(Supplementary Relative)

Also following Potts (2005), we can make the following observations about supplementary meaning. First, the anchor and its supplement compose to form a proposition. For example, in (34b), the meanings ‘Ames’ and ‘who stole from the FBI’ compose to form the proposition ‘Ames stole from the FBI’. Secondly, the composition of this proposition is semantically detached from the rest of the composition process. This

independence of the supplement proposition’s meaning from the main (at-issue) content of the utterance is two-sided. On the one hand, the composition of the anchor and supplement occurs in isolation, meaning that it cannot make reference to semantic objects apart from the anchor and supplement themselves. On the other hand, once the supplementing proposition is composed, its meaning takes widest scope as a speaker-oriented commitment, and cannot affect the surrounding composition.

4.6.2 Nominal Supplements

When supplementing material anchors to quantificational DPs, we immediately gain evidence as to the type of the DP in question. Consider (35), which is pragmatically odd, given the knowledge that John and Mary are common names.

(35) Two students, John and Mary, had unusual names.

If ‘two students’ were interpreted as a generalized quantifier, there would be no way to capture the oddness of (35). Let’s see why. First, we have to ask what happens when the GQ meaning composes with ‘John and Mary’, which denotes a plurality. Even if we supposed that this composition were licensed (say, by type-shifting the plurality to a property using Montague’s BE), we would just derive a weak meaning of ‘Two students are John and Mary’ as the supplement proposition. But crucially, there is nothing odd about two students being John and Mary and two students having unusual names. Yet, the sentence cannot have this weak meaning.

On the other hand, if ‘two students’ gets a choice-functional reading, the composition proceeds without a hitch and the oddness of the sentence is captured. Suppose that in logical form, the subject contains a choice function variable f_7 which composes with the meaning ‘two students’ to produce a particular plurality of two students. In this case, the supplementing proposition will be that those two students picked out by f_7 are John and Mary, and the at-issue meaning will be that those same two students have unusual names. This fixing of the two students across the two proposi-

tions comes for free on the assumption that choice function variables are free variables bound once at the level of discourse, following Kratzer (1998, 2003).

Since (35) only allows a choice-functional interpretation of the subject, and in particular lacks the meaning predicted if the subject were a GQ, we can use this sentence frame to test whether other quantifiers have choice functional interpretations. For example, in (36), we see that ‘few students’ is unable to anchor a nominal apposition. This is supporting evidence for the view that ‘few students’ can never be interpreted as type e.

(36) *Few students, John and Mary, had common names.

More generally, we can hypothesize that even if no other interpretation is possible, a GQ is still unable to stand as anchor to a nominal apposition. If there were a convincing exception to this generalization, it would involve a sentence where the GQ could be shown to be evaluated twice and witnessed by two different sets of individuals—once in the supplement, and once in the at-issue dimension. I know of no data that suggest such an option is ever available. Consider that even to the marginal degree that (36) is interpretable, the meaning still requires that we identify John and Mary rather than anyone else as the few students who have common names.

In (37), I test a range of quantifiers on their ability to host nominal appositions. Once again, the pattern that emerges is that the EE quantifiers—the *some*s and *most*s—behave as a class distinctly from the non-EE ones—the *few*s. We have a natural explanation for these facts if all the EE quantifiers and only the EE quantifiers give rise to type-e nominals.

(37) _____ of my students, (namely) the ones who wanted to pass, came on time.

{
 Some | Ten | Many | Several | A few
 Most | More than ten | Exactly ten | Half
 *None | ??Few | ??Not many | ??Less than ten
}

Note that as with the equatives, the use of a partitive supports the felicity of the *mosts* as type e. Here, we need to be careful to ensure that the supplement isn't attaching to the nominal inside the partitive, in this case 'my students'. While this is certainly a possible syntactic parse, in this particular example the meaning would be unnatural. Specifically, the backgrounded claim that my students are "the ones who wanted to pass" is odd without a contrasting set in the context. We can also note that the partitive is not strictly necessary. With the exception of *half*, the diagnostic gives the same split if the frame is "_____ students, namely the ones who wanted to pass, came on time."

On a related note, we may ask why *all* is unnatural in the frame above, despite being existence-entailing. Again, this appears to be a problem with the meaning conveyed rather than with the types involved. The supplement 'the ones who wanted to pass' inherently picks out a subset of some group, and so is not a good characterization of all of the students. However, we can show that *all* does license supplements with examples like the following:

(38) All contestants qualified to enter the next round, (namely) John, Mary, Sue and Bill, should now proceed to the stage.

Another quantifier that warrants extra discussion is 'at most *N*'. As a non-EE quantifier, we expect 'at most two' to pattern with 'less than three' and resist supplements. However, such examples are well-formed, as in the following, adapted from Corblin (2007):

(39) He invited at most two people, his father and his mother.

The key to the puzzle here, following Krifka (1999) and Corblin (2007), is that ‘at least’ and ‘at most’ are not exclusively determiners, and may combine with full DPs, as in (40). Thus the supplement in (39) can be understood as modifying the existence-entailing ‘two people’, and does not constitute an exception to our generalization.

(40) He invited { at most | at least } John and Mary.

By comparison, ‘less than’ is unable to attach to full DPs, and as a non-EE quantifier, resists supplements:²²

- (41) a. *He invited less than John and Mary.
b. ??He invited less than three people, (namely) his father and his mother.

4.6.3 Relative Clause Supplements

Relative clause (RC) supplements, also known as NON-RESTRICTIVE or APPOSITIVE relative clauses, add further support for the emerging pattern. As with nominal appositions, RC supplements are incapable of attaching to non-EE DPs like ‘few students’. The core data are as follows:²³

²²Krifka (1999) discusses the example “The aggressors wanted more than the southern province”, which seems at least marginally possible with ‘less than’, as in “They wanted less than the southern province.” I suspect that this depends on the amount of territory desired being a gradient notion, as compared with numbers of people, which are inherently discrete.

²³The supplementing adverb *incidentally* ensures that the relative clause is non-restrictive; see Emonds (1979: 64) and Potts (2005: §4.7) for discussion. Without the adverb, the judgments of infelicity depend solely on the comma intonation, and are less robust. If these pauses are absent or overlooked, the clause can be interpreted as restricting the NP ‘congressmen’, giving the meaning ‘Few junior congressmen admire Kennedy’. Another potential confound is that we need to ignore kind-modifying interpretations of the relative clause, on which juniorness is predicated of congressmen in general. Thank you to Ezra Keshet for pointing out this latter issue.

(42) _____ congressmen, who incidentally are very junior, admire Kennedy.

{
 Some | Ten | Many | Several | A few
 Most | More than ten | Exactly ten | At least ten
 *Few | *Not many | *Hardly any | ??Less than ten
}

The basic explanation for these facts is the same as before. Like nominal appositions, RC supplements can only attach to individual-denoting expressions. However in this case, it's less clear what is driving the restriction. At least as far as the types are concerned, there seems to be no incompatibility between a GQ-denoting anchor and a property-denoting relative clause. But the data show us clearly that such a representation is illicit. Beyond the badness of the "fews", we see that none of the acceptable quantifiers in (42) allow GQ readings either. For example, the sentence with *some* can't mean just that some congressmen are very junior and some congressmen admire Kennedy. The two sets must coincide.

Whatever its source is, a ban on non-individual-denoting anchors is commonly assumed to be in effect, and is often relied upon to do important work. For example, Karttunen (1969: §1.1) observes that a non-restrictive relative disambiguates to a specific reading of an otherwise ambiguous indefinite anchor, as in (43). Similarly, Heycock and Kroch (1999: 374) show that predicative DPs, as in the object of the small clause in (44), resist non-restrictive RCs. See Sells (1985), Potts (2002) and Del Gobbo (2003: 152) for further discussion, and arguments that even non-nominal anchors must be able to denote type e.

(43) Bill didn't see a misprint, which I had made on purpose.

(44) *I consider Rita the duty nurse, who is very efficient.

4.6.4 Other Supplements

Another type of supplement that draws out the same class of quantifiers is *including* phrases, as in (45). If a subject like 'few American cities' only has a GQ meaning and if we allow it to compose directly with a supplement, then we would at best produce as the supplementing meaning a nonsensical proposition like 'Few American cities include New York and Chicago'. On the other hand, if the subject can denote a plurality, then we derive a sensible meaning. With the EE quantifiers in (45), a particular plurality of cities is claimed to have subways, and this same plurality is parenthetically specified as including New York and Chicago. If the non-EE quantifier phrases were able to denote pluralities (e.g. of few cities), then we would expect the supplement to add information about these pluralities, but the infelicity of these sentences shows that this is impossible.

(45) _____ American cities, including New York and Chicago, have subways.

$$\left\{ \begin{array}{l} \text{Some | Ten | Many | Several | A few} \\ \text{Most | All | More than ten | Exactly ten | Half of} \\ \text{\#Few | \#Not many | \#Hardly any | \#Less than ten} \end{array} \right\}$$

This diagnostic deserves extra care because of seeming counter-examples like (46). The important point here though is that (46) cannot be interpreted as meaning that New York and Chicago are among the few American cities to have had an 8.0 earthquake. This implies that the sentence does not have a reading on which 'few American cities' denotes a plurality of few cities and the supplement elaborates on this plurality.

(46) { Few | Hardly any | Less than ten } American cities, including New York and Chicago, have ever had a magnitude 8.0 earthquake.

The question of how (46) is interpreted at all is an interesting one, but I will not resolve it here. One option would be to say that the *including* phrase, rather than anchoring directly to the subject, is a sentence level modifier that serves to extend the domain of quantification. This meaning would be paraphrasable as “(Even) Including New York and Chicago, few American cities have had an 8.0 earthquake.” However while I believe this reading is available, it seems to me that (46) has another, more natural interpretation where New York and Chicago are claimed specifically to not have had 8.0 earthquakes. While I do not have an analysis of how this reading is derived, it is clear that it cannot arise if ‘few American cities’ denotes a plurality and anchors the *including* phrase supplement. If this were the case, the subject would have to denote a set that included cities that had not experienced heavy earthquakes (New York and Chicago), but then the main clause would claim to the contrary that this same set *had* experienced heavy earthquakes.

4.7 Discourse Referents and Type-e Meaning

It is common to describe indefinites that denote a specific individual as being REFERENTIAL. However, I have avoided this term throughout because it suggests too strong of an association between being type e and the ability to introduce discourse referents. The first task of this section is to review evidence showing that this association is not bidirectional. Phrases which are unable to denote type e, may nevertheless introduce discourse referents that can be picked up by anaphors. However, the association does appear to hold in the other direction. That is, if a phrase denotes an individual, it should be possible to refer back to that individual in subsequent discourse. Thus, the second task of this section is to show that, contrary to findings in the literature, all the

type-e expressions discussed above, and in particular modified numeral expressions *can* introduce referents.

An important contrast appears when we compare nominal supplements, which are directly linked to their anchor by semantic equality, to E(vans)-type pronouns, which are linked to an antecedent by a different mechanism. In (47), we have the classic example from Evans (1980), illustrating the existence of pronouns that are not bound by a preceding quantifier, but nevertheless refer back to a referent established by that quantifier.

(47) Few congressmen admire Kennedy, and **they** are very junior.

On recent dynamic theories of anaphora, including van den Berg 1996, Nouwen 2003, Brasoveanu 2007 and Schlenker 2011, *all* quantificational phrases introduce discourse referents that can serve as antecedents for anaphora. For example, on its most natural interpretation, *they* in (47) refers back to the set of congressmen that admire Kennedy, which is introduced to the context in the process of evaluating the clause containing the quantifier. Importantly though, this does not imply that the phrase ‘few congressmen’ semantically denotes that referent. In fact, the minimal pairs below are evidence that even in a context where ‘few congressmen’ can clearly introduce a referent, it cannot denote type e:

- (48) a. Few congressmen, and they are very junior, admire Kennedy.
b. ??Few congressmen, who are very junior, admire Kennedy.

- (49) a. Kennedy is admired by few congressmen, and they are very junior.
 b. ??Kennedy is admired by few congressmen, who are very junior.

How exactly ‘few congressmen’ introduces referents is a complicated question that we won’t resolve here. Nouwen (2003) shows with examples like (50) that such phrases can introduce a variety of referents, depending on the context. In (50c) it is particularly apparent that *they* cannot be referring back to an individual denoted by ‘few senators’, since the resulting meaning would be contradictory. For the present discussion, it suffices to observe that discourse referents can be recovered through pragmatic means. This is to say, the availability of a discourse referent to be picked out by an anaphor tells us nothing about whether any of the phrases in the sentence actually denote that referent.

- (50) a. Few senators admire Kennedy; and **they** are very junior.
 b. Few senators admire Kennedy. Most of **them** prefer Carter.
 c. Few senators admire Kennedy. **They** admire Carter instead.

(Nouwen 2003: ex. 1.13, 1.18, 1.19)

On the other hand, there still remains a puzzle as to whether the link between semantic denotations and available discourse referents goes the other direction. If a phrase denotes an individual, shouldn’t that individual always be an option for anaphora? Given the flexibility of anaphors to pick up various inferred referents seen in (50), it would seem hard to prevent a referent that corresponds to the denotation of an overt constituent from being available as an antecedent. However, the following data seem to point in this surprising direction.

Kadmon (1987), Kamp and Reyle (1993), Szabolcsi (1997) and subsequent authors observe a difference between bare numerals like ‘five students’ and modified numerals like ‘more than four students’. In (51a), when *they* looks back to ‘five students’, its referent may be a *subset* of the students that left shortly after the exam started. In

(51b), however, the pronoun has to pick out the exhaustive set of *all* students that left shortly after the exam started; it can't refer to some non-exhaustive set of more than four students that the speaker has in mind. I will refer to the intersection of the restrictor and nuclear scope as the REFERENCE SET (following Nouwen 2003), and refer to cases of anaphora to a proper subset of the reference set as NON-EXHAUSTIVE.

(51) a. Five students left shortly after the exam started.

They could not understand the questions.

b. More than four students left shortly after the exam started.

They could not understand the questions.

The conclusion that Reinhart and others take from these facts is that modified numeral expressions do not have choice-functional readings, and hence do not denote individuals. Conversely, if we say that 'more than four students' can denote any plurality of more than four students (as returned by a discourse-bound choice function variable), then it is a mystery why *they* in (51b) can't refer to a particular non-exhaustive set of five or more leavers, as opposed to the entire set of leavers.

On the present analysis, 'more than four students' is in principle compatible with both type-e and GQ interpretations. However we are not immediately committed to the view that both readings are available in any context. The approach I pursue here is to posit a pragmatic dispreference for the type-e reading in certain contexts.²⁴

Looking to a wider range of examples, we find that the unavailability of the non-exhaustive interpretation for (51b) cannot be blamed entirely on the modified numeral. The following dialogue shows that in the right context, modified numerals and *most* can introduce referents that are non-exhaustive with respect to their reference set. Specifically, the pronoun *their* in (52) refers back to a particular large

²⁴An alternative would be to maintain that the type-e reading is always available, but that there are pragmatic constraints on how choice function variables are bound at the level of discourse.

set of students that have signed the petition, but plausibly fails to correspond to the entire set of students have (at this point in time) signed. On the most natural interpretation, *their* picks out just those students who had signed by the time I signed yesterday.

(52) A: Have all of the students signed the petition?

B: I'm not sure. But { **most** | **more than 100** | **at least 100** } **students** have signed it...

A: Oh? How do you know that?

B: I saw **their** names on the petition when I signed it yesterday.

How then should we understand the difference between (51b) and (52)? One striking feature of (52) is that the context makes salient a property that could characterize a non-exhaustive portion of the reference set—in this case, the property of having already signed the petition by the time I signed yesterday. I submit that in contexts where no such property is salient, non-exhaustive readings are strongly dispreferred.

In thinking about why the non-exhaustive interpretation of (51b) is missing, it is useful to ask what the sentence can be used to do. There are two options. The first, and more likely option, is that the statement is being used to answer a (possibly implicit) question of how many students left early. In this case, the speaker considers the entire set of early-leavers, and uses 'more than four' as an imprecise, but still informative answer to the question of the set's size.

The second option is that the speaker has a particular group of students in mind—say, a subset of the early-leavers—and wishes to convey that this group left early. The problem with using (51b) to do this is that without contextual support, it's hard to imagine that I have a particular group in mind but have no better way of characterizing this group to you than a lower limit on its size. One reason this weak characterization is so unsuccessful is that 'more than four' will not only apply to the subset I have in mind, but also necessarily to the entire set of early-leavers. By

comparison, if there are ten early-leavers, ‘five students’ in (51a) *can* do the work of picking out a subset of them.

To summarize, when an anaphor picks up a referent introduced by a quantificational DP, we see a strong preference for identifying the anaphor with the quantifier’s reference set (cf. Nouwen 2003). However, if the quantificational DP can denote type *e*, which may require some contextual support, then anaphors can refer back to the denotation of the quantificational phrase, and non-exhaustive interpretation is possible.

Given examples like (52), we need to reconsider claims in the recent dynamic literature (see Schlenker 2011: 346–7 and references therein) that all non-indefinite quantifiers, including *most* and *more than three* introduce referents together with explicit maximality conditions. Rather, it appears that these maximality conditions are in effect only when the DP in question is GQ-denoting. If this is the case, it should be impossible to find examples like (52) with decreasing quantifiers like *few*.

4.8 Implementing the Type-e Account

In section §4.3, we established the need for nominals with CT-marked quantifiers to have type-*e* interpretations and generate type-*e* alternatives. However it’s not immediately clear how to implement this in a framework where focus alternatives are computed compositionally. This section presents some issues that arise in this connection, and puts forward a preliminary proposal that makes use of choice functions. It should be noted however that the main findings from above—namely, that CT-marked quantifier phrases denote type *e*, and that EE quantifiers allow type-*e* readings—are in no way contingent on the success of this particular proposal, and do not in of themselves necessitate a choice-functional implementation.

On Reinhart’s (1997) implementation of the choice functional account, indefinite quantifiers serve as cardinality-restricting modifiers to a property-denoting NP, and a

null choice function variable in the specifier of DP combines to produce a particular individual satisfying this modified property. Thus, the structure of ‘three cats’ will be $[f_7 [\text{three cats}]_{\text{NP}}]_{\text{DP}}$, where f_7 is a choice function variable. With respect to contrastive topic (which chapter §3 argued should be implemented via F-marking), the problem with this approach is that this structure doesn’t contain an appropriate constituent to be F-marked to produce the desired set of alternatives. Crucially, we want the alternatives to vary both the quantifier and the CF variable, while leaving the restrictor constant. For example, if ‘THREE cats’ denotes a particular threesome of cats, we want its focus alternatives to be the set of other pluralities of cats (including singletons). With Reinhart’s structure, if we F-mark the CF variable alone, we restrict the alternatives to all have the same cardinality of three. On the other hand, if we F-mark the numeral alone, the choice function remains fixed and we only predict a single alternative for each cardinality.²⁵

Given Reinhart’s structure, if we want to F-mark a constituent that contains both the CF variable and the cardinality modifier, our only option is to F-mark the entire DP. But is marking the entire DP a viable option in cases where only the determiner is stressed? This is not a trivial question to answer. There are two issues at play. First, given that the default rules of phonology place an accent rightward in cases of broad focus (cf. Selkirk 1984 and many others), we would have to explain what conflicting force is pushing the accent leftward. This could potentially be explained if the restrictor is treated as GIVEN in the sense of Schwarzschild (1999) or Wagner (2006b), and if given material resists accenting as on Féry and Samek-Lodovici 2006 or Kratzer and Selkirk 2007. Second, recall that we want the alternatives to ‘THREE cats’ to be pluralities of *cats*, not dogs or other animals. Since on a standard alternative-semantic

²⁵This could be avoided by appealing to modifiers with meanings like ‘three or four’ and ‘three or five’ to generate contrasting threesomes. However, I assume that such cardinalities will not be available unless made explicitly salient.

analysis, broad focus on the DP would generate non-cat alternatives, we would have to say something about how these alternatives are kept out of the computation. Even if such an account can be motivated, there is still a conceptual challenge, in that the availability of a broad focus analysis should not rule out the possibility of narrow focus. That is, it would be puzzling if narrow focus on a quantificational determiner were ruled out entirely, since generally speaking it appears that any constituent, including even sub-word constituents can be F-marked (cf. Artstein 2004). For these reasons, I follow Büring (1997b) and Rooth (2005) in assuming that stress on the determiner implies narrow focus on the determiner.

Given these challenges for the standard choice-functional structure, we should consider alternative structural implementations. Rooth suggests that quantifiers like *some* and *many* can denote choice functions directly, but does not propose specific denotations. Suppose that when these quantifiers occur in referential nominals, we encode the cardinality component of the quantifier’s meaning as a presuppositional modifier to a choice function variable. On this view, a referential DP with a stressed quantifier like ‘MANY cats’ would have the structure $[[f_7 \text{ many}]_F \text{ cats}]$. Compositionally, there are several ways to achieve the desired effect. One would be to assume that *many* has, in addition to its standard denotation, a meaning as a choice function modifier, adding a presuppositional restriction on the cardinality of the entity returned by the choice function, as follows:

$$(53) \quad \llbracket \text{many} \rrbracket = \lambda f_{\langle (e,t), e \rangle} \lambda P_{\langle e,t \rangle} [f(P) \text{ if } |\text{Atoms}(f(P))| > 5, \text{ otherwise undefined}]$$

This approach has the disadvantage of requiring duplicate higher-order denotations for every cardinality predicate like *many*. To avoid this redundancy, we can introduce a silent morpheme that carries the load of getting a choice function and a cardinality predicate to combine in the way we want. For instance, we can use a silent operator Φ to transform a choice function meaning into a function from cardinalities to restricted

choice functions, as in (54). In this case, the phrase ‘MANY cats’ would have the structure $[[[\Phi f_7] \text{ many}]_F \text{ cats}]$.

$$(54) \quad [[\Phi]] = \lambda f_{\langle(e,t),e\rangle} \lambda P_{\langle e,t\rangle} \lambda Q_{\langle e,t\rangle} [f(Q) \text{ if } P(f(Q)), \text{ otherwise undefined}]$$

In terms of the morphological realization of such structures, we could either assume that a quantifier like *many* spells out the entire [variable + modifier] complex (cf. gender marking on pronouns), or else that it spells out the modifier alone, and the choice function is silent. I see no immediate consequences of this decision, so leave the issue open here.

To illustrate this particular rendering of the choice-functional account, let’s walk through the analysis of a simple CT+Exh example on the topic abstraction theory presented in chapter §3. For simplicity, I assume the denotation for *many* from (53), although the results are the same if we use Φ :

$$(55) \quad [\text{MANY}]_{CT} \text{ students ... live in } [\text{AMHERST}]_{\text{Exh}}$$

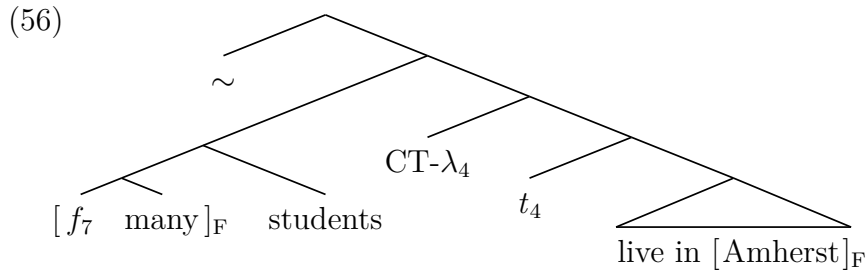

Following the usual procedure for computing focus alternatives (cf. Rooth 1985: 56), the focus value of the F-marked constituent $[f_7 \text{ many}]$ will be the set of all choice functions, as in (57a). Since for every set of students, there is some choice function that maps the property *student* onto that set, the focus alternatives to the subject will be the set of all pluralities of students, as in (57b).²⁶

²⁶Incidentally, different choice functions may map the property *student* onto one and the same output, provided the functions differ on some other element of their domain. However, this does

- (57) a. $\llbracket f_7 \text{ many} \rrbracket^f = D_{\langle\langle e,t \rangle, e \rangle}$
 b. $\llbracket f_7 \text{ many students} \rrbracket^f = \{ X \mid X \in D_e \text{ and student}(X) \}$

Plugging in our semantics for the CT operator from chapter §3, the focus value for the entire utterance will be the set of questions “For each plurality of students, where does that plurality live?”. When combined with the modified version of Rooth’s squiggle operator proposed in §3.2, the prediction is that (55) is anaphorically dependent on a (potentially implicit) strategy of questions contained within this focus value. Thus, before or after (55) is uttered, there will be other sub-questions of the form “Where does *that* group of students live?” that need to be answered as well. Since (55) is natural in such contexts, and even out of the blue seems to leave a residual question of exactly this form, the analysis is highly plausible.

One may be skeptical as to whether we need or want to generate so many alternatives to the CT phrase. For instance, should we really permit overlapping topic alternatives? The following examples would seem to suggest that overlapping pluralities can’t serve as contrasting topics. In (58), when *half* contrasts with *half*, it seems impossible to construe the halves as overlapping, despite the plausibility of bilingualism. Furthermore, in (59), there is nothing logically anomalous about one majority speaking English and a different (necessarily overlapping) majority speaking Chinese. However when two occurrences of *most* are marked as CT, the result is odd. One way to account for these facts would be to demand that only choice functions which will return non-overlapping alternatives enter into the computation.

not imply that a plurality could contrast with itself, or somehow appear more than once in the alternative set. As sets, F-values can contain no duplicates. Thus, the cardinality of (57a) will exceed that of (57b).

(58) A: What languages do the students in your class speak?

B: [HALF]_{CT} of the students ... speak [ENGLISH]_{Exh}.

And [HALF]_{CT} of them ... speak [CHINESE]_{Exh}.

(59) A: What languages do the students in your class speak?

B: [MOST]_{CT} students ... speak [ENGLISH]_{Exh}.

#And [MOST]_{CT} students ... speak [CHINESE]_{Exh}.

But apart from being difficult to cast formally, it turns out that this stipulation has undesirable effects. For one, such a stipulation would rule out the possibility of contrasting overlapping sets as in the following:

(60) A: How many points did each team score?

B: [John, Bill and MARY]_{CT} scored [TEN]_{Exh} points.

[Sue, Bill and ANN]_{CT} scored [TWENTY]_{Exh} points.

I suspect that the problem with overlapping topics in (58) and (59) relates to a difficulty in determining the strategy by which the speaker aims to move toward resolving the larger question under discussion. But in any case, there can be no general constraint against overlapping topics, so we need not concern ourselves with ruling them out at the level of the compositional semantics. As usual, on Rooth's alternative semantics, having more values in an alternative set than we need for a given discourse is never a problem, since the function of focus values is not to identify the elements that are being contrastively evoked directly, but rather to constrain the possible values of these elements, which are treated as anaphors, and subject to contextual resolution.

4.9 CT and Scope

On the topic abstraction account presented in chapter §3, a CT phrase is the associate of a CT operator in the left periphery, and is interpreted via LF movement to that

operator position. One broad claim of the account then, is that information structure is not orthogonal to the LF structure that is used to compute scope/binding relations. Rather, the scope and topic/focus status of constituents are encoded configurationally on the same tree structure.²⁷

An analysis like this that fixes the scope of the CT phrase at LF has the potential to make predictions about where CT quantifiers will take scope with respect to other scope-bearing elements. However what exactly the predictions are is a more complicated matter than one might assume. In this section, I argue that we do in fact want an analysis where CT-marking restricts the options for scope-taking.

Intuitively, one might expect that since CT phrases are interpreted high in the structure, a CT-marked quantifier phrase would always take widest scope above other quantifiers or operators like negation. This naive prediction is clearly incorrect though, for example in cases where a CT-marked quantifier scopes under negation or a negative quantifier. For instance, in the following example of lone CT, adapted from Büring (1997a: 180), the CT-marked *all* scopes under negation:

(61) [ALL]_{CT} politicians aren't corrupt... (not > all)

However, a more careful look at the semantics of topic abstraction reveals that the prediction made is in fact precisely the opposite: that a CT phrase will take narrow scope. To see why, consider the LF in (62). While the CT phrase is interpreted in a high position, this does not in of itself imply wide scope over negation. Whether movement of a quantifier phrase affects scope relations depends on what semantic type we assign to the trace left behind—in this case t_7 . By comparison, the way in which standard quantifier raising (QR) enacts wide scope is by allowing a raised GQ phrase to bind a type-e trace. If the moving element and its trace are of the *same* type,

²⁷In this sense, the present account is more economical than the model in Bobaljik and Wurmbrand 2012, which relies on distinct representations for topic/focus structure and traditional scope.

we rather have a case of so-called SEMANTIC RECONSTRUCTION (cf. Lechner 1998, Romero 1998 and Fox 1999) where the movement is effectively undone for the purposes of interpretation.

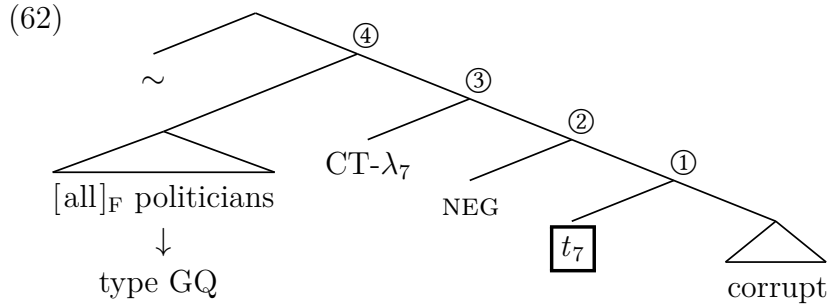

One interesting consequence of the topic abstraction mechanism is that a QR-style scope-taking configuration is ruled out automatically as the result of a type mismatch. Recall the semantics for CT- λ given in section §3.2:

- (63) a. $\llbracket \text{CT-}\lambda_i \phi \rrbracket_g^o = \lambda x. \llbracket \phi \rrbracket_{g[i \rightarrow x]}^o$ (Ordinary Semantic Value)
 b. $\llbracket \text{CT-}\lambda_i \phi \rrbracket_g^f = \{ \lambda x. \llbracket \phi \rrbracket_{g[i \rightarrow x]}^f \}$ (Focus Semantic Value)

The critical fact here is that the CT operator’s output in the focus dimension is (a singleton containing) a function to alternative sets. This novel type of semantic object is relatively inflexible in how it can be used. We can provide it an argument, and get an alternative set back. However, unless we stipulate new composition rules, such a function to sets is not viable as the argument to another function—unless that function is specifically looking for a function to sets. This is precisely the problem we run into if the trace in (62) is of type e. In the focus dimension, the GQ alternatives to ‘all politicians’ are looking to combine (pointwise) with property arguments of type $\langle e, \langle s, t \rangle \rangle$.²⁸ But what the CT operator produces is not the expected type of function

²⁸I’ve moved explicitly to an intensional semantics for this portion of the discussion, so as to be able to talk of sets of propositions (of which there are many) as opposed to sets of truth values (of which there are very few). As always, my assumption is that world arguments are represented overtly in the semantics, even when I have not realized them notationally.

from individuals to propositions, but instead a function from individuals to *sets* of propositions. Since the GQs are unable to combine with such a function to alternative sets, the overall F-value $\llbracket \textcircled{4} \rrbracket^f$ is undefined. This is shown in the following derivation:

$$\begin{aligned}
(64) \quad & \text{If trace } t_7 \text{ is type e...} \\
& \llbracket \textcircled{2} \rrbracket_g^f = \{ g(7) \text{ isn't corrupt} \} \\
& \llbracket \textcircled{3} \rrbracket^f = \{ \lambda x. \{ x \text{ isn't corrupt} \} \} \\
& \llbracket \textcircled{4} \rrbracket^f = \boxed{\text{CRASH!}}
\end{aligned}$$

On the other hand, if the trace is of the same GQ type as the moving CT phrase, the structure is interpretable as in (65). Note that within the derivation I use $\langle \text{GQ} \rangle$ as a shorthand for the intensionalized GQ type $\langle \langle e, \langle s, t \rangle \rangle, \langle s, t \rangle \rangle$. The resulting F-value captures the fact that (61) is answering one among a set of questions about different GQ meanings (i.e. proportions). One might rephrase the intended contribution of (61) as “I might agree that *most* politicians are corrupt. But as for *all*... no, not *that* many are corrupt.”

$$\begin{aligned}
(65) \quad & \text{If trace } t_7 \text{ is type } \langle \text{GQ} \rangle \dots \\
& \llbracket \textcircled{2} \rrbracket_g^f = \{ \neg [g(7)](\lambda x. x \text{ is corrupt}) \} \\
& \llbracket \textcircled{3} \rrbracket^f = \{ \lambda G_{\langle \text{GQ} \rangle} \{ \neg G(\lambda x. x \text{ is corrupt}) \} \} \\
& \llbracket \textcircled{4} \rrbracket^f = \{ \{ \neg G(\lambda x. x \text{ is corrupt}) \} \mid G \in D_{\langle \text{GQ} \rangle} \} \\
& \quad = \left\{ \begin{array}{l} \{ \text{All politicians are corrupt} \} \\ \{ \text{Most politicians are corrupt} \} \\ \dots \end{array} \right\}
\end{aligned}$$

Given that the trace left by a raising CT needs to be the same type as the CT phrase itself, and given the semantics of topic abstraction in (63), CT movement will never affect meaning in the ordinary dimension, and thus never affects scope relations. The only effect of raising a phrase to the CT operator position will be to induce nesting in the focus dimension, where that phrase’s alternatives will be sorted out above others’. But if topic raising is inert for the purposes of scope-taking, then we need to ask how

CT-marked quantifiers *ever* take wide scope. On the most salient reading of (66), for example, the CT-marked *some* scopes above the object quantifier. The expected narrow-scope CT reading (66b) by comparison is strongly dispreferred, and depends on a context supporting proportional contrasts, along the lines of (10) above.

- (66) [SOME]_{CT} students ... solved [less than THREE]_{Exh} problems.
- a. ‘Some students x are such that x solved less than three problems.’
(Subj_{CT} > Obj_{Exh})
 - b. ‘Less than three problems x are such that some students solved x .’
(Obj_{Exh} > Subj_{CT})

Generating the dispreferred but possible narrow-scope CT reading is relatively simple. The following LF applies quantifier raising (QR) to give the object ‘less than three problems’ scope over the subject. Additionally, CT movement targets the subject, raising it to a yet higher position; but per the discussion above, this must leave a higher-type trace, so the movement is vacuous for the purposes of determining scope relations.

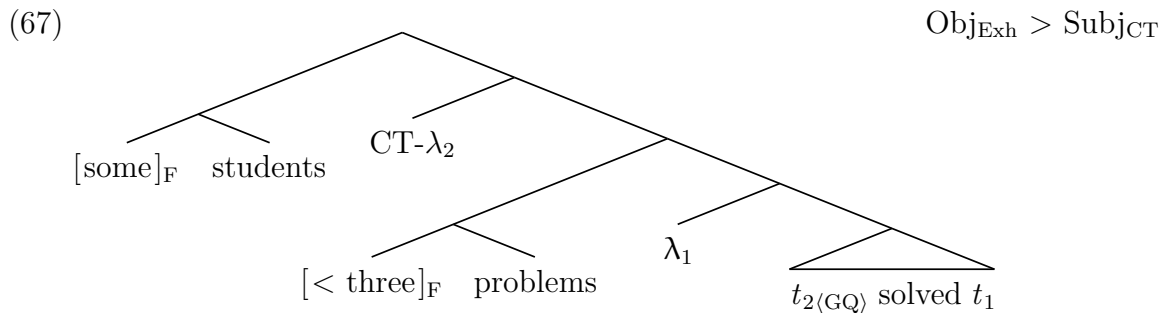

But how do we generate the more salient wide-scope CT reading, (66a)? One option for capturing this reading would be to allow CT raising to apply to the output of QR, as in (68).

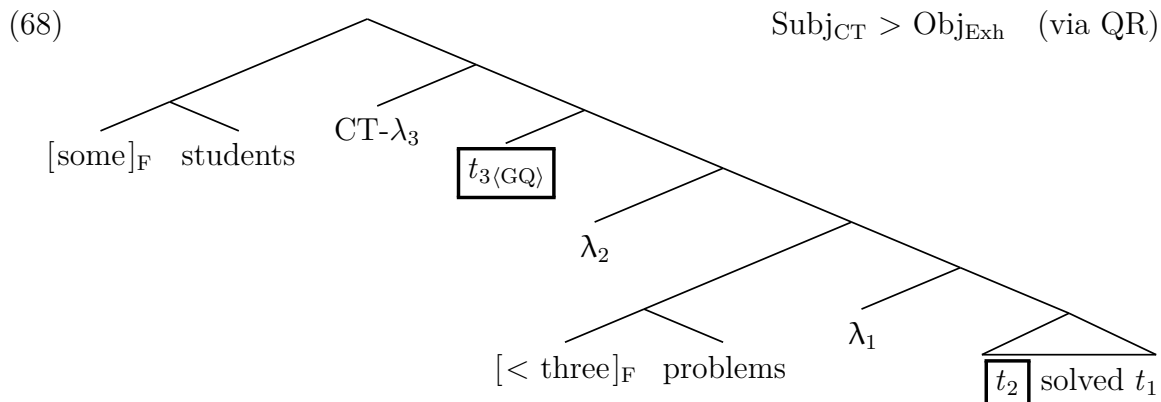

However, I take this to be the wrong approach, since it predicts the availability of wide-scope CT readings irrespective of the quantifier involved. We will see in a moment that this does not fit the facts. More generally, allowing QR to feed topic movement as in (68) predicts no direct correlation between CT-marking and scope. It would permit any CT to scope low as in (66a), or to scope high as in (66b). And while this may seem like a good thing for (66), it turns out that such a model is too permissive. In general CTs *are* restricted to scope low, and wide scope is only available in special circumstances.²⁹ In particular, I claim that apparent cases of wide scope CT in fact depend on interpreting the CT phrase by the same mechanism that allows indefinites to take so-called “exceptional” wide scope. Thus, following the discussion in §4.3, these readings involve CTs that are referential, and hence have no scope at all.

To get a clear picture of the scope facts, we have to fix our attention on nominals that we can be confident are robustly quantificational. Based on our findings from sections §4.4–§4.6, this is a highly restricted set of quantifiers—just the non-existence-entailing (non-EE) ones. Consider (69), where we have replaced the indefinite *some* with the non-EE quantifier *few*. Now, the only reading available has the CT subject taking narrow scope. As with (66), the narrow-scope reading depends

²⁹Similar conclusions are reached for Hungarian by Gyuris (2008) and for German by Endriss (2009), although I cannot offer a full comparison with these models here.

heavily on contextual support for contrasting proportions. But the important point is that regardless of context, there is no reading where *few* is CT-marked and gets wide scope.

- (69) [FEW]_{CT} students ... solved [less than THREE]_{Exh} problems.
- a. *‘Few students x are such that x solved less than three problems.’
*Subj_{CT} > Obj_{Exh}
 - b. ‘Less than three problems x are such that few students solved x .’
Obj_{Exh} > Subj_{CT}

We can draw out the impossibility of (69a) more clearly by contrasting the non-EE quantifier *few* with the EE quantifier *a few* in a context that supports the wide scope reading:

- (70) (The test was way too hard. I gave the students over an hour to finish it, but most of them still only managed to solved around half of the problems.)
- a. And [a FEW]_{CT} students ... solved [less than THREE]_{Exh} problems!
 - b. *And [FEW]_{CT} students ... solved [less than THREE]_{Exh} problems!

These data provide striking evidence for both (i) the topic abstraction account, which guarantees narrow scope for CT-marked GQs, as well as (ii) the claim that EE quantifiers allow type-e readings, which explains why most CT-marked quantifiers support, and even prefer (apparent) wide scope. We can also note here that while pragmatic factors alone can account for the absence of wide-scope CT *all* (cf. Büring 1997a), these explanations are not enough to capture the impossibility of wide-scope CT *few*, or other non-maximal decreasing quantifiers. That is, the topic abstraction account covers a superset of the scope facts that can be explained by purely pragmatic means.

Given the lack of wide scope CT *few*, we can conclude that the output of QR must not be a valid input for CT movement. Ideally, we would be able to identify this restriction as part of a more general pattern. For example, one could imagine

that there exists a general ban on the appearance of traces of different types within a single movement chain. Another option would be to try to unify this restriction with previous observations concerning the inability of one A-bar movement to feed another (see e.g. Epstein 1992). However I will not speculate on these connections further here.

Returning to our apparent wide-scope example (66b), we are now forced to treat the subject CT as referential. As a result, we get the interpretation we want (where the valuation of the subject doesn't co-vary with the valuation of the object) without appealing to scope at all. This is shown in the following structure:

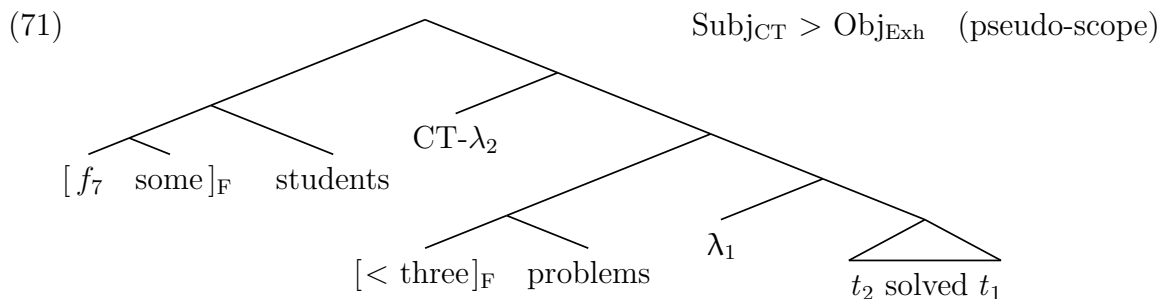

Beyond letting us hold onto the narrow scope CT generalization, this analysis captures an important observation about (66a) vs. (66b). As we saw in section §4.3, contrastive topic is sensitive to, and diagnoses the semantic type of the phrase it marks. Thus, in (66a), where we've determined that the CT phrase is a GQ, the discourse must be one that contrasts GQs, and more specifically, goes through a strategy of questions, where each question concerns a different GQ. By contrast, in (66b), where the CT phrase must be type e, we predict a discourse with type-e topic alternatives. These predictions are exactly right. In particular, we already saw that a context contrasting proportions is needed to support (66a). By the same token, if we explicitly mark contrast with pluralities rather than proportions, the narrow-scope CT reading is impossible:

- (72) [SOME]_{CT} students ... solved [less than THREE]_{Exh} problems.
[OTHER]_{CT} students ... solved [EVERY]_{Exh} problem.
- a. 'Some students x are such that x solved less than three problems.'
(Subj_{CT} > Obj_{Exh})
 - b. #'Less than three problems x are such that some students solved x .'
#(Obj_{Exh} > Subj_{CT})

CHAPTER 5

ENGLISH CT PROSODY

This chapter presents a detailed model of how sentences containing CT are pronounced in English. We'll begin by exploring the realization problem in general terms, as well as showing some particular problems facing previous accounts. The topic abstraction account developed in chapter §3 is located within a larger class of “configurational” theories, and we see a general roadblock for this family of accounts. The challenge is that no widely adopted view of the syntax-phonology interface will give the phonology access to the distinctions in logical form that configurational accounts rely on to distinguish CT phrases from other foci.

The remainder and bulk of the chapter focuses on the topic abstraction model, and presents an explicit theory of how topic abstraction structures are translated into prosodic contours in English. The essential claims of the account are as follows:

- (1) a. In English, the CT operator is pronounced as a rising tone (L-H), which is moreover required to cliticize to the right edge of an intonational phrase.
- b. Prosodic structure is built in accordance to universal constraints on syntax-prosody correspondence and prosodic markedness (Selkirk 2011b).
- c. English F-marked phrases (including CTs and other alternative-generating elements) want maximal prominence within the scope of the operator binding them (Truckenbrodt's 1995 FOCUS-PROMINENCE).
- d. A novel Scope-Prosody Correspondence (SPC) constraint requires the CT operator and its associate to surface within the same intonational phrase.

The novel SPC constraint in (1d), building on work by Hirotsu (2005), is what allows the phonological component of grammar to distinguish CT phrases from other foci, even while locally they are all just F-marked phrases. By incorporating this constraint into our model of the syntax-phonology interface, we derive a complex series of predictions as to how English sentences with CT are phrased. The core predictions of the final account are listed in (2) and treated in detail in the second half of the chapter.

- (2)
- a. CT+Exh and Exh+CT orders are not symmetrical in their phrasing.
 - b. The CT morpheme can surface at a distance from the CT phrase.
 - c. The CT morpheme never occurs island-internally.
 - d. There is some optionality in the positioning of the CT morpheme.
 - e. The prosody is sensitive to whether multiple CTs are bound by the same operator (complex CT) or different operators (nested CT).

After presenting the basic account (sections §5.2–§5.6), I'll consider briefly how variants of the model proposed for English may be able to account for word order effects of CT in other languages (section §5.7). The final sections §5.8–§5.10 consider an alternative account and address remaining issues.

5.1 Realizing CT-Marks and CT Configurations

Previous accounts of how English CT is realized fall into two camps. The traditional camp encodes which constituent is CT directly with a syntactic feature, and stipulates how the CT-marked constituent will be realized in the prosody, e.g. as L+H* L-H%. This approach has its roots in Jackendoff's (1972: 258) distinction between A and B

accents, and is taken up in Roberts’ (1996) and Büring’s (2003) work on CT, as well as much subsequent work. I will refer to these accounts as “CT-marking” accounts.¹

To take a simple example, CT-marking accounts treat CT+Exh sentences using distinct features CT and Exh on the two focal constituents. Recall that here and throughout I’ve replaced previous authors’ use of F to mark exhaustive focus with the unambiguous Exh. (See section §2.1 for the notion of exhaustive focus used here and throughout.) Thus, Jackendoff’s classic example will have the following syntax and phonology:

- (3) [FRED]_{CT} ... ate [the BEANS]_{Exh}.
 L+H* L-H% H* L-L%

By contrast, contemporary approaches to CT meaning, including Tomioka 2010b, Wagner 2012, and the present work, take a CT phrase to be just an F-marked constituent in a particular configuration. (This is the canonical use of F to mark alternative-generating focus in the broadest sense, cf. Rooth 1992, Krifka 2007.) For these theories, the CT and Exh phrases are locally similar in structure, and differ only in how their alternatives are *used* higher up in the structure. We can draw parallels to alternative-based constructions elsewhere in the grammar. For example, the focus associates of *even* and *only* are standardly taken to be simply F-marked, with the difference in how they are interpreted deriving from the choice of focus operator binding them. Similarly, indeterminate pronouns are fruitfully analyzed as generating Hamblin alternatives that can be used up in different ways by operators

¹Jackendoff and Roberts don’t have CT features *per se*. In fact, Roberts specifies that both CT and Exh are “Focus”. However, they both depend on some way of marking a CT locally that has both interpretive and prosodic consequences.

higher in the structure, including existential and universal quantifiers (see Kratzer and Shimoyama 2002).²

I will refer to approaches that do without CT marks in the syntax as CONFIGURATIONAL accounts. The task of a configurational theory is to establish what configuration defines a focus as CT, and to model how this configuration is spelled out in surface syntax and phonology.

The remainder of this section takes a more detailed look at the traditional and contemporary approaches, focusing on the issue of whether they can provide a satisfactory treatment of CT realization. I begin by describing several serious problems for CT-marking theories, which will lead us to abandon them in favor of a configurational theory. Next, I lay out what a configurational theory should account for, and review how several options on the market fall short of this goal.

5.1.1 Problems for CT-Marking Theories

As we saw in chapter §3, there are both conceptual and empirical problems for CT-marking, stemming from how CT-marks are interpreted. To review briefly, on the conceptual side, an explicit model of CT-marking requires no small amount of new semantic machinery. As we see in Büring 2003, beyond the stipulation of how CT is interpreted relative to a discourse, a full account needs to add a new dimension of interpretation (for CT-values) with a novel and complex system of composition rules that are not needed elsewhere. One hopes to do without this. On the empirical side, we saw that Büring's (2003) implementation of the CT-marking account runs into trouble with (i) CT questions, (ii) multiple CT, and (iii) CT island effects. It is not clear whether these issues could be avoided within a CT-marking system.

²Whether indeterminate pronouns are formally F-marked, and whether the alternatives are housed in the same dimension as focus alternatives are interesting questions, but the parallel is clear regardless.

Even if the above problems were solved, there are equally serious problems concerning how CT marks translate to surface realizations. Here again, there are both conceptual and empirical issues. Focusing on the English facts, the traditional view is that CT-marked phrases are somehow directly associated with Jackendoff’s B accents. However this view proves to be conceptually unappealing in light of what a B accent is. As Jackendoff’s (1972: 258) discussion makes clear, what he dubs a B “accent” actually consists of a detailed specification of the tonal material covering a large intonational unit. Translated into standard ToBI notation (Pierrehumbert 1980), the B accent—which I will refer to as a “contrastive topic contour” from here on—specifies tonal values for the components of an entire intonational phrase. Specifically, a CT contour consists of a rising pitch accent, a low phrase tone, and a high boundary tone: L+H* L-H%.³ However allowing the direct mapping of a syntactic feature onto a full intonational phrase specification seems stipulative and overly powerful. On the more modular account I present below, CT meaning is directly tied to the boundary tone L-H% while the presence of the pitch accent is a general reflex of focus.⁴ In broad terms, this modular account is compatible with the attractive view that separate pieces of an intonation contour make discrete contributions to the interpretive component (Pierrehumbert and Hirschberg 1990).⁵

Beyond the conceptual problem that CT-marking accounts enforce stipulative mappings across the syntax-prosody interface, there are issues of empirical adequacy. To say that a CT-marked phrase is realized as L+H* L-H% still leaves open several

³While the pitch accent in the CT contour is typically specified as L+H*, it is not at all clear that a differently shaped accent (like H*) or differently aligned accent (like L*+H) would convey a different meaning. See section §5.9 for further discussion.

⁴On this account, the shape and alignment of the pitch accent are left unspecified, although these could potentially be treated as independent meaning-carrying devices. See section §5.9 for further discussion.

⁵Liberman and Sag (1974) argue that at least one intonation contour—the “contradiction contour”—should in fact be treated holistically, both in terms of its phonology and its interpretation.

important questions about where these various pieces will surface. Lone CT examples are one place where this uncertainty arises. If the CT-marking on *Fred* in (4) is to be realized via a contrastive topic contour, why is the L-H% portion of that contour so far away from the CT phrase itself?⁶

(4) (Did Fred and Mary eat the beans?)

[FRED]_{CT} ate the beans...
 L+H* L-H%

Similarly, what controls the position of the L-H% boundary in a CT+Exh example like (5)? While the unmarked pronunciation (5a) squeezes the entire contour onto the CT phrase, many speakers also allow renditions where the intonational phrase boundary is delayed, as in (5b). Similar judgments are reported by Rooth (2005: ex. 10c) and Steedman (2008: ex. 34a). I mark variable acceptability across speakers with a ‘%’ sign, and assume that a sufficient theory of CT should be able to model the grammars of both speakers who reliably accept and those who reliably reject these forms.

⁶Such examples pose a direct challenge to Büring’s (2003: 537) proposal that “CT-marking is realized by a boundary tone on the constituents so marked”. One might try to defend this proposal by maintaining that (4) is actually a case of broad sentential CT. The meaning contribution of such a broad CT structure, on Büring’s system or my own, will be less informative than the narrow scope structure, but nothing can rule the possibility of semantic underspecificity; the pragmatics can bear the burden of restricting back to just the relevant discourse strategy. However this still begs the question of how narrow lone CT on the subject would be pronounced, or alternatively why it is ruled out. Furthermore, this path of escape is not available in cases like (5b), where the boundary tone fails to correspond to the right edge of *any* constituent.

(5) (What about FRED? What did HE eat?)

- a. [FRED]_{CT} ... ate [the BEANS]_{Exh}.
 L+H* L-H% H* L-L%
- b. % [FRED]_{CT} ate ... [the BEANS]_{Exh}.
 L+H* L-H% H* L-L%

These examples highlight a fundamental question that has not been addressed on CT-marking approaches. Is the intention for CT-marking to *induce* intonational phrase breaks? If so, what is the mechanism by which it does? Or should CT marks rather be seen as simply providing a floating tonal specification that is hung over an existing prosodic structure, built on more general principles? This latter choice would be in line with a long line of work that derives prosodic structure from syntax (Selkirk 1978/1981, 1986, 2011b; Nespor and Vogel 1986; Truckenbrodt 1999). On either approach, something needs to be said to allow for the variation in (5). Furthermore, the solution must distinguish between (5), where many speakers can delay the rising boundary, and (6) where delaying is impossible (cf. Rooth's 2005: ex. 12c). It appears that the rising CT boundary cannot encroach on the domain of an Exh phrase.⁷

(6) (What about FRED? What did HE do?)

- a. [FRED]_{CT} ... [ate the BEANS]_{Exh}.
 L+H* L-H% H* L-L%
- b. # [FRED]_{CT} [ate ... the BEANS]_{Exh}.
 L+H* L-H% H* L-L%

Another factor that affects the positioning of the rising boundary is the presence of islands, as we saw in section §3.1.4. When CT occurs within an island, as in (7), the

⁷For the Exh focus to unambiguously cover the entire VP, we need to ensure that the question of what Fred ate is not recoverable from the context. In a context where asking what Fred did amounts to asking what he ate (say, faced with a difficult choice of eating beans or haggis), the same pronunciation as (6b) could be construed as narrow focus on the object, and would presumably be judged felicitous by those speakers who accept (5b).

boundary tone is delayed until the edge of the island.⁸ CT-marking accounts have not accounted for this fact.

(7) (What about MARY? Did SHE bring something tasty?)

- a. The dish that [MARY]_{CT} brought ... was [SUPERB]_{Exh}.
 L+H* L-H% H* L-L%
- b. *The dish that [MARY]_{CT} ... brought was [SUPERB]_{Exh}.
 L+H* L-H% H* L-L%

If we pass off the placement of intonational boundaries to the syntax-prosody interface, there is hope of ruling out (7b) as a poor choice of alignment of syntactic constituents with prosodic constituents. However, examples like (5b) above and (8) below show that at least there can be no general ban on placing an intonational phrase break clause-medially between arguments.

(8) (What about MARY? What did you give HER?)

- I gave [MARY]_{CT} ... [the ORANGES]_{Exh}.
 L+H* L-H% H* L-L%

Another challenge for CT-marking accounts is the fact that, according to many authors' intuitions, a CT constituent is not always associated with its own intonational phrase. Specifically, in Exh+CT examples like (9), Pierrehumbert and Hirschberg (1990: ex. 33) and Steedman (2000: ex. 4, 2008: ex. 34b) discuss realizations of the entire sentence in a single intonational phrase.⁹ While the CT contour L+H* L-H% does surface in its entirety, the appearance of non-CT material within the same

⁸Again, one may contest the LF and say that the CT in (7) is the entire constituent 'the dish that Mary brought'. While this is a reasonable analysis, we still need an explanation of how the narrow CT structure can and cannot be realized. As we've seen in sections §3.1.4 and §3.4, there can be no general constraint against island-internal CT.

⁹These intuitions could also be seen as supported by the experimental work of Liberman and Pierrehumbert (1984), although they present a different interpretation of their results. They observe that in Exh+CT examples, there is a surface downtrend through the two peaks, while in CT+Exh examples, the two peaks are of roughly equal height, suggesting a pitch reset triggered by a larger prosodic break. See section §5.8.2 for further discussion.

intonational phrase makes it hard to maintain that the CT feature translates into a full intonational phrase specification. Furthermore, we would like to understand why Exh+CT can (or perhaps must) be phrased together, whereas CT+Exh apparently cannot.

(9) (What about the BEANS? Who ate THOSE?)

[FRED]_{Exh} ate [the BEANS]_{CT} ...
 H* L- L+H* L-H%

Finally, examples like the following from Büring (2003: 536) show that a CT phrase itself may be internally complex, containing more than one accent. This is again a direct challenge to any model that aims to map a CT feature directly onto a fixed prosody.

(10) (Where will the guests at Ivan and Theona’s wedding be seated?)

[FRIENDS and RELATIVES of the couple]_{CT} ... will sit [at the TABLE]_{Exh}.
 L+H* L+H* L-H% H* L-L%

With Büring, I believe that such examples indicate the need for F-marking within the CT constituent, and that it is the F marks, rather than CT, that are responsible for the presence of pitch accents. On this view, CT marks are simply responsible for controlling the presence and location of the rising L-H% boundary. However, as we saw above, this rising boundary doesn’t track the CT phrase directly. Thus, it can be argued that we can do without CT marks entirely. This is the path that configurational theories take.

To sum up, however we formalize the effect of CT on prosody, it can’t be as simple as saying that the CT phrase robustly corresponds to a particular prosodic unit with a particular tonal makeup. There are non-trivial questions about how CT interacts with phrasing. On the one hand, the location of CT-marking doesn’t immediately determine the location of the rising boundary tone. On the other hand, the location

of that boundary doesn't seem to be predictable from a sentence's syntactic structure alone. We need a theory that can explain the *influence* CT-marking has on phrasing, while still leaving room for other factors to have their effect as well.

5.1.2 The Task for Configurational Theories

Contemporary approaches to CT meaning, including Tomioka 2010b, Wagner 2012, and the present work, take a CT phrase to be an F-marked constituent in a particular configuration. As we saw above, there are conceptual and empirical advantages to a CT-mark free account. However it is a real challenge to explain how the presence of an F-marked phrase in a particular configuration should have any specific effect on the prosody. To my knowledge, no one has given even a preliminary account of how CT is realized in a configurational framework.

For comparison, the following diagrams show the configurations that the three accounts mentioned above posit for the sentence “[Fred]_{CT} ate [the beans]_{Exh}”. For Tomioka, a CT phrase is a focus associate of a CT operator that is not also the associate of an Exh operator. For Wagner, a CT phrase is the focus associate of the higher of two FOCUS operators. On the topic abstraction account presented in chapter §3, a CT phrase is simply the focus associate of a CT operator. We'll treat each structure individually in more detail in what follows.

(11) Tomioka 2010b

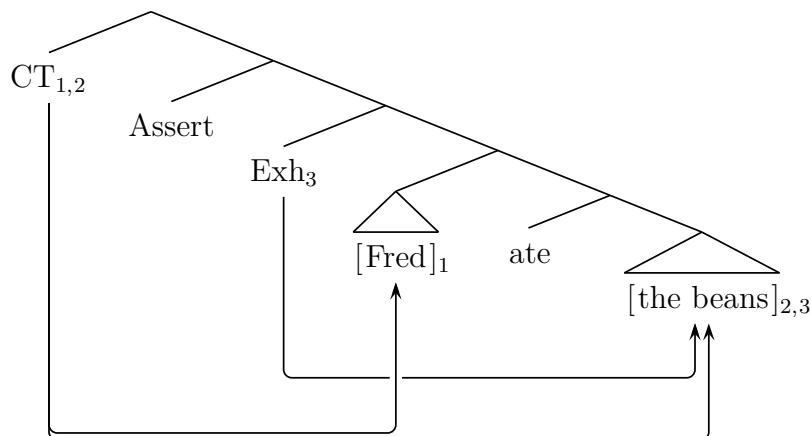

(12) Wagner 2012

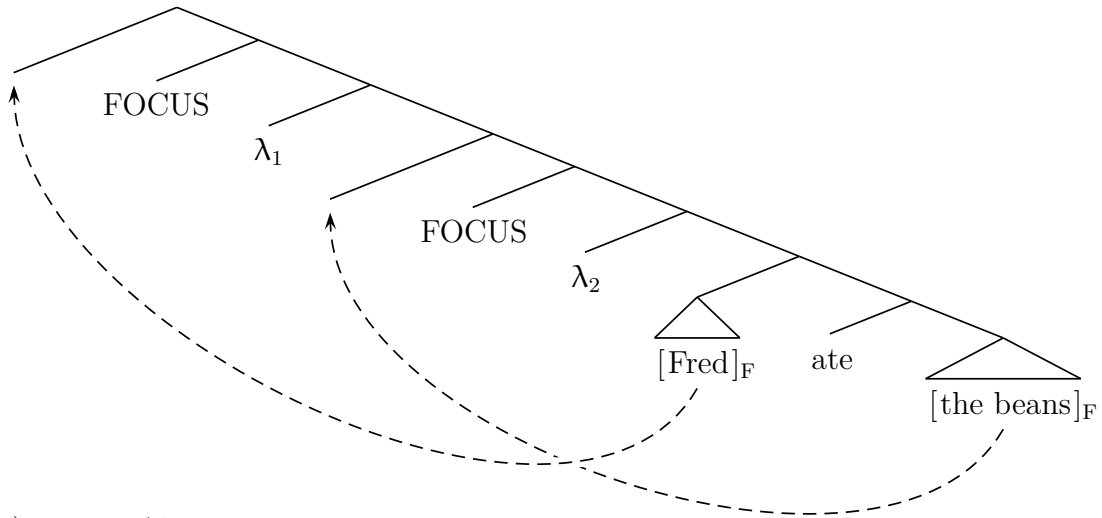

(13) Topic Abstraction

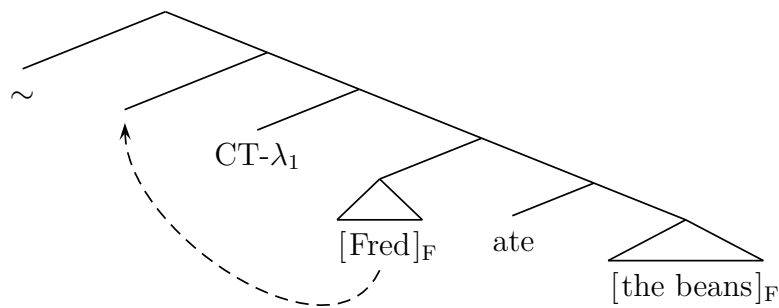

Before looking at the differences between these accounts, we can consider a common question they all face. By what interface mechanism(s) could these structures come to be realized with CT prosody? In the previous section, we saw that even if the CT and Exh phrases are marked with dedicated features, it is still difficult to predict where the various pieces of the CT contour will surface. By comparison, configurational theories seem to be even further away from being able to make the right predictions, or any predictions, about English prosody. Of course, the CT and Exh phrases are still identifiable to the analyst in configurational terms. But we have to ask, is it justifiable to grant the phonology direct access to this structural information? For example, would it be reasonable to simply stipulate that the focus associate of a

particular operator must be realized with a rising accent, and must occur within a low-rising (L-H%) intonational phrase?

At best, allowing such a stipulation would reduce the configurational accounts to the same challenges we saw above for CT-marking theories. But there is an additional sacrifice of generality. An ideal model of prosodic structure formation will be compact, with the effects of different components of grammar on prosody clearly circumscribed. With few exceptions, major theories of the syntax-prosody interface have respected this ideal. For example, the alignment-based theories of Selkirk (1986, 1996) and McCarthy and Prince (1993) aim to reduce the role of morphosyntax on prosody to a set of general constraints that align the edges of syntactic units with the edges of prosodic ones. Later theories that incorporate additional constraints on how focus is phrased, including those of Selkirk (1995, 2000), Truckenbrodt (1995, 1999) and others still aim to limit the possible effects of focus marking on prosody. These theories would not for example predict sensitivity to the choice of operator binding a focused phrase. Rather, focus is treated uniformly using general constraints that ask for focused material to be prominent. If a model of CT requires a serious departure from this simple, general, and constrained view of the interface, it would seem to bear the burden of defending the need for the move toward complexity.

Let's now consider the three configurations for CT proposed above, and see exactly what interface mechanisms we would have to postulate to get from these structures to the surface prosody. First, consider the model of Tomioka 2010b. This is a scope-driven theory of CT, on which a CT phrase is bound by a high-scoping CT operator, whereas an Exh phrase is bound not only by the same CT operator, but also by a lower Exh operator. No covert movement is assumed. The CT and Exh phrases are interpreted in situ, and what differentiates them is the choice of focus indices they bear, which determines in turn which focus operators will bind their alternatives. This is achieved within Wold's (1996) system of selective binding, building on the work of

Kratzer (1991). The particular data Tomioka discusses come from Japanese, but I will consider English examples, and assume that the structural account would carry over without any modification. I restrict attention to ditransitive examples in the following discussion, so that we can ignore the possibility that a subject CT phrase has overtly raised to a topic position. The structures in (14) illustrate how CT+Exh and Exh+CT examples are represented on this theory. The question at hand is, how do we map (14a,b) onto their pronunciations in (15a,b)?

- (14) a. CT_{1,2} Assert Exh₃ I gave [Fred]_{F1} [the beans]_{F2,3} CT+Exh
 b. CT_{1,2} Assert Exh₃ I gave [Fred]_{F1,3} [the beans]_{F2} Exh+CT
- (15) a. I gave [FRED]_{CT} ... [the BEANS]_{Exh}.
 L+H* L-H% H* L-L%
- b. I gave [FRED]_{Exh} [the BEANS]_{CT} ...
 H* L- L+H* L-H%

The problem is, from the point of view of the phonology, (14a) and (14b) look very similar. In fact, their syntactic structures are identical, even down to the choice of which constituents bear focus marking. The only difference between the two forms is in which focus phrases associate with which focus operators. So, at a minimum, this model of CT depends on a phonology that has access to focus operator-associate binding relations.

Looking in more detail, the difference between (14a) and (14b) is in which argument is bound by Exh and which is not. Since the CT phrase is the one that ends up bearing the atypical rising topic contour, arguably the simplest approach to the data would be for the phonology to target this phrase and stipulate its realization. However here we run into the problem that it is only possible to identify the CT phrase in negative terms. Specifically, a CT phrase is any focus associate of a CT operator that is *not* also bound by an Exh operator. But why would just phrases in this special configuration receive a fixed prosodic realization?

The configurational account proposed in Wagner 2012 faces a similar challenge. Here, the task is to correctly map the structures in (16a,b) onto the CT+Exh and Exh+CT contours from (15a,b) above. Note that in what follows I am departing from Wagner’s actual proposal by incorporating Exh+CT structures under a unified configurational account. Recall that for Wagner, apparent cases of Exh+CT are in fact unrelated to CT, and involve a distinct rise-fall-rise morpheme. See section §3.6 for arguments that Exh+CT and lone CT examples are best treated under a theory of CT meaning. In any case, our immediate concern is how CT+Exh and Exh+CT are distinguished on theories that cover them both.

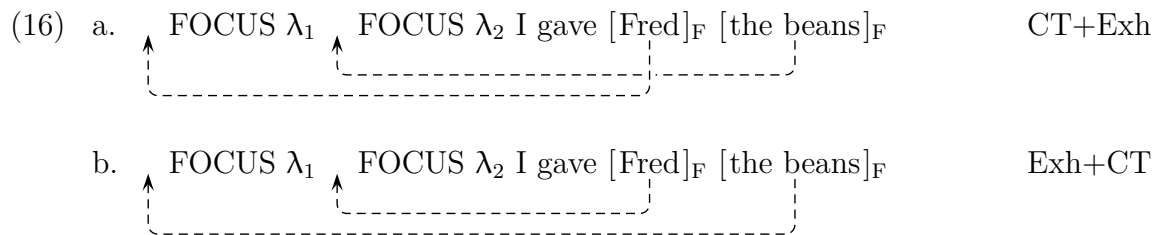

Unlike Tomioka’s account, Wagner’s proposal handles focus association using covert LF movement, building on work by Krifka (2006) and Wagner (2006a). The arrows in (16) indicate the covert movement of the CT and Exh phrases to the higher and lower FOCUS operator positions respectively. On the common conception of LF movement, this movement is by definition invisible to the phonology. One framework that makes this inaccessibility explicit is the widely adopted inverted Y model of Chomsky and Lasnik (1977):

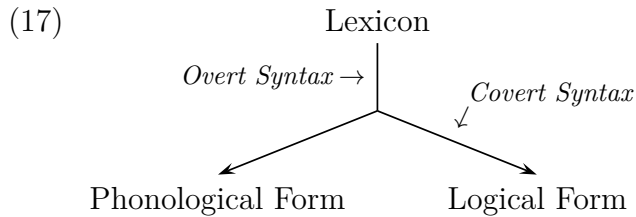

Within this architecture, there is simply no way of capturing the fact that the two structures above are to be pronounced differently. As far as spellout is concerned, the LF movements indicated above “haven’t happened yet”; the structures sent to PF are identical. On the other hand, if we adopt the copy theory of movement (Chomsky 1993), there is an option for covert movement to take place in the “stem” before the split between LF and PF, so that both the launch and landing sites are accessible to the phonology. For example, on the “single-output” model of Bobaljik (1995, 2002), what makes some copy-movements covert is the phonology’s decision to spell out the lower copy rather than the higher one.

How should we begin to address the issue of interface mechanics under a Wagner 2012 style account? Suppose that by one means or another, the phonology gets access not only to the surface positions of the focused phrases in (16), but also to their post-LF-movement positions. Thus, the covert movements in (16) are visible, and the spellout problem amounts to understanding how these movements affect the prosody. But even after taking this contentious step forward, it is still difficult to formulate a plausible account of the prosodic facts. On this model, both the CT and Exh phrases move to a FOCUS operator position at LF, so there is little to distinguish them. In fact, what defines a CT phrase is just that it is the phrase associating with the *higher* FOCUS operator.¹⁰ But why should the phonology be sensitive to this relative notion? Furthermore, if we consider the nested CT structures discussed in

¹⁰Wagner (2012: 34) also considers the possibility of a two-place CTOPIC operator that associates with both the CT and Exh phrases. On this approach, we would need to stipulate that the *first* associate of the operator is realized with CT prosody, and the *second* with Exh prosody.

section §3.5, we see that it is not enough to specify the CT as the highest FOCUS associate. Rather, the lowest FOCUS associate ends up with Exh prosody, and all other associates get CT prosody.

Last of all, we can turn to the topic abstraction account. Like Wagner’s proposal, this account depends on LF movement of the CT phrase to an operator position. And like Wagner’s proposal, the target of this LF movement is the only factor distinguishing CT+Exh from Exh+CT structures. Thus, the account demands a phonology with some access to LF structure. The potential advantage of the topic abstraction account is that once we grant this access, it is trivial to identify the CT phrase in structural terms. On this account, a CT phrase is any phrase that moves to a CT operator position at LF. This is illustrated in the following pair:

- (18) a. \sim $\overset{\text{CT-}\lambda_1}{\uparrow \text{I gave [Fred]}_F \text{ [the beans]}_F}$ CT+Exh
 b. \sim $\overset{\text{CT-}\lambda_1}{\uparrow \text{I gave [Fred]}_F \text{ [the beans]}_F}$ Exh+CT

To sum up, models of CT to date haven’t given a satisfactory account of how English CT is realized in the prosody. CT-marking theories like Büring 2003 bypass standard interface mechanics, and are challenged by (i) cases where the CT phrase doesn’t line up directly with the “CT contour”, and (ii) the apparent asymmetry between CT+Exh and Exh+CT in phrasing.¹¹ Configurational models, on the other hand, have done no better, and make the unconventional demand that the phonology be sensitive to either focus binding relations or LF movement. At the very least, a configurational theory should present an explicit mechanism by which the prosody is to be derived. The remainder of this chapter presents and motivates such a mechanism

¹¹We’ll return to the question of whether there is indeed an asymmetry between CT+Exh and Exh+CT in section §5.8. While intuitions in the literature point toward an asymmetry (see page 219), experimental work is needed to (dis-)confirm these introspective judgments.

under the topic abstraction account. The result is promising in a number of ways. First, it adopts a scope-prosody correspondence constraint of the type discussed by Hirotsu (2005) as the only unconventional extra piece of interface mechanics. Second, it predicts asymmetries between CT+Exh and Exh+CT that appear to be justified. And finally, it gives us a way of understanding cases where the CT phrase and the CT contour don't line up. More specifically, we will treat all the examples in (4–10) that challenged the CT-marking theory.

The remainder of the chapter presents a comprehensive account of how English CT is realized under the topic abstraction theory. First, I'll motivate the idea that the CT operator is lexicalized as a tonal clitic to the intonational phrase (§5.2). Next, I'll address the question of what factors affect the phrasing of utterances containing a CT (§5.3). Beyond the widely-discussed effects of syntax on prosody (including the effects of F-marking), I argue for a novel scope-prosody correspondence constraint that requires the CT operator and its associate to be realized within a single intonational phrase (§5.4). After motivating the account and showing how it works on basic examples, I demonstrate that it extends to capture both the delayed boundary data that challenged Büring (§5.5) as well as multiple CT data (§5.6). The final sections (§5.7–§5.9) discuss outstanding issues, including possible extensions and alternatives.

5.2 CT Operator as IntP Clitic

It is an attractive prospect to treat the rising CT boundary (L-H%) as the realization of a morpheme with a fixed position in the syntax, no different from morphemes spelled out by segmental material. This understanding of tonal material occurring at the edge of large prosodic units has been advocated by Chao (1968: 812), Hyman (1990: 122–123), Selkirk (1995: 562, fn. 11) and Yip (2002: 271–273), all of whom draw a specific connection between intonational morphemes and discourse particles. The topic abstraction account of CT lends itself especially to this type of analysis, in that

we can identify a specific morpheme—the CT operator—that is present whenever a CT boundary occurs. Thus, in what follows, I assume that in English, the CT operator is lexicalized as L-H%. (See section §5.8 for an alternative where L-H% originates with the CT phrase, as a spell-out of agreement with the CT operator.) If segmental CT particles are also realizations of the CT operator, as I argue in chapter §7 for the case of Mandarin *-ne*, then the basic difference between English and languages with CT particles reduces simply to the choice of tonal vs. segmental material to realize this functional morpheme.

Precisely what information is encoded in the lexicalization of CT as L-H%? Beyond the sequence of tones L and H, I have specified with the % sign where the morpheme will go in the prosodic structure: at the right edge of an intonational phrase (IntP).¹² The idea that morphemes can make specific demands for the prosodic structure they attach to is supported by a long line of research in prosodic morphology (see McCarthy and Prince 1995 and McCarthy 2006 for an overview). Much of that work is dedicated to showing that the positioning of certain morphemes, including templatic and reduplicative morphemes, is best characterized in terms of the domains of the prosodic hierarchy (mora, syllable, foot, prosodic word, and so on). Although comparatively few cases have been discussed of morphemes that display sensitivity to larger prosodic categories (e.g. phonological phrase, intonational phrase), it is natural to expect these as well.

And while less widely studied, there are still a number of prominent claims that such morphemes exist. Inkelas (1991) argues that clitics subcategorize for specific prosodic domains, and provides examples of clitics to the phonological phrase from Hausa and Kivunjo Chaga (pp. 245–259). Moving higher up the prosodic hierarchy,

¹²Within the ToBI system, the L- phrase tone is usually assumed to attach to a smaller prosodic unit (the phonological phrase), whereas the H% attaches to a larger unit (the intonational phrase). For simplicity, I will assume that the entire rising tone sequence is specified just as an intonational phrase clitic, and that the positioning of L- can be determined by phonological spreading rules.

Aissen (1992), Skopeteas (2010) and Gutiérrez-Bravo (2011) discuss clitics to the intonational phrase in the Mayan family. Furthermore, many authors contributing to the large body of work on South Slavic clitics argue that the positioning of these clitics must make reference to a large unit of prosodic structure, perhaps the intonational phrase.¹³ See in particular Radanović-Kocić 1996 (Serbo-Croatian), Legendre 2000 (Bulgarian), Bošković 2001 (Serbo-Croatian, Bulgarian and Macedonian), Zec 2005 (Serbian) and Werle 2009 (Bosnian, Serbian, Croatian). Finally, with respect to tonal morphemes, Hyman (1990) advances the claim that several Bantu languages have tonal clitics that select for the intonational phrase (see Zec and Inkelas 1992 for a summary). Overall, there is ample precedent for positing a morpheme whose lexical specification requires it to occur at a particular high-level prosodic boundary.

Another possibility worth considering is that L-H% originates with the CT phrase itself, as a reflex of an agreement relation with the CT operator—along the same lines that English tense agreement is realized on the verb. I will postpone discussion of this alternative analysis to section §5.8.

5.3 Factors Affecting the Boundary Position

Moving forward, let's assume that the rising CT boundary is guaranteed to cliticize to the end of some intonational phrase. But what decides the position where this prosodic boundary will occur? Here, I will consider three increasingly refined options, only the last of which is sufficient to capture the facts. The first option equates the position of the CT boundary directly with the position of the CT operator in the syntax. The second option incorporates other controlling factors from the syntax-prosody

¹³Here, I want to avoid placing too much emphasis on the particular names that authors use to refer to a given prosodic domain in a given language. There are complicated issues involved in assessing whether what we call an IntP in one language lines up in a meaningful way with what we call an IntP in another. In many cases, it is not clear on what basis the notational decision has been made, and in this case, the naming should be seen as somewhat arbitrary. However see Selkirk (2011b) for a principled approach to assigning stable cross-linguistic definitions to the prosodic categories.

interface—syntax-prosody correspondence constraints, focus prominence constraints, and phonological markedness constraints on prosodic structure formation. The third option adds to these a novel constraint on scope-prosody correspondence, and is thereby able to cover the entire paradigm of facts we have seen.

Let’s begin with the simplest account, on which the CT morpheme is always spelled out locally at the position it occupies in the syntax. Given that this morpheme needs to be IntP-final, the prosody “responds” by creating an IntP break at the position of the CT operator. In topicalization examples like (19), where the contrastive topic is overtly moved to the left of the CT operator, this simplistic account gets the job done. In this case, the CT boundary surfaces directly following the CT phrase, as Büring predicts. Note that in this and the following discussion, I am just aiming for an account that can position the rising CT boundary correctly, and am not concerned with the source of the falling IntP boundary (L-L%) or the choice of pitch accents (L+H* vs. H*¹⁴).

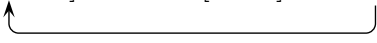
- (19) a. \sim [the beans]_F CT- λ_1 [Fred]_F ate t_1
- 
- b. [The BEANS]_{CT} ... [FRED]_{Exh} ate.
L+H* L-H% H* L-L%

What about lone CT examples, where the rising boundary is sentence-final, and potentially at a distance from the CT itself? Recall from section §3.4 that the semantics of topic abstraction are insensitive to whether it’s the F-marked CT phrase alone or some larger containing phrase that raises to the CT operator position. Specifically, we saw that the meanings generated are identical as long as no F-marked material

¹⁴One possibility is that the falling boundary tone is inserted by default, at the edge of an IntP whose boundary is not lexically specified. This would parallel Selkirk’s (2008: 226) analysis of tonal insertion in Bengali to satisfy a constraint calling for the edge of every PhonP to be aligned with a tone. Another possibility is to assume an interpreted assertion morpheme, spelled out by a final fall, as suggested by Bartels (1997: 101).

other than the CT occurs within the moved constituent. Given this equivalence, one initially plausible analysis of lone CT is in terms of overt topicalization of the entire sentence, as in (20). By positing this movement, we could maintain that the CT operator always spells out locally (in the left periphery), and still derive its sentence-final position.

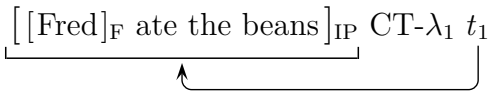
- (20) a. \sim $\underbrace{[[\text{Fred}]_F \text{ ate the beans}]_{\text{IP}}}_{\text{CT-}\lambda_1} t_1$

- b. $[\text{FRED}]_{\text{CT}} \text{ ate the beans} \dots$
 $\text{L+H}^* \qquad \qquad \qquad \text{L-H}\%$

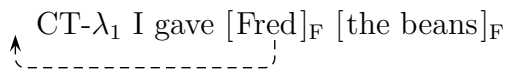
However, such an account becomes untenable when we turn to examples where the CT phrase is left in situ. For instance, in (21) the rising boundary occurs following the CT ‘Fred’, despite the fact that the CT operator is to its left in the syntax. Here the dashed arrow indicates the covert movement of ‘Fred’ that is needed for interpretation. However, it would be difficult to argue that overt topicalization has taken place. If ‘Fred’ has moved to a position leftward of the CT operator, then how is it that the non-constituent ‘I gave’ surfaces in an even higher position?

- (21) a. \sim $\underbrace{\text{CT-}\lambda_1 \text{ I gave } [\text{Fred}]_F}_{\text{dashed arrow}} [\text{the beans}]_F$

- b. $\text{I gave } [\text{FRED}]_{\text{CT}} \dots [\text{the BEANS}]_{\text{Exh.}}$
 $\text{L+H}^* \text{ L-H}\% \qquad \qquad \qquad \text{H}^* \text{ L-L}\%$

Since the position where the CT operator L-H% surfaces can’t be read directly off the syntactic structure, we need to consider additional factors that affect prosodic phrasing. This brings us to our second option, which incorporates general constraints on prosodic structure formation. For our purposes, the essential feature of this model is that the CT operator is allowed to spell out at a distance from its syntactic position. Let’s assume specifically that, as an IntP enclitic, the CT operator is pronounced at the first IntP boundary following it. In this case, the question is what independently

determines the positioning of IntP breaks. Here, a number of detailed proposals already exist that aim to derive prosodic phrasing from syntactic structure through general principles. In what follows, I adopt Selkirk’s (2009, 2011b) match theory, which provides a simple and explicit model of the interface. Note however that earlier edge-based theories (Selkirk 1986 and many following) would also suffice for the particular task ahead.

The basic tenet of match theory is that prosodic structure is derivable from the syntax through the interaction of two families of ranked constraints: (i) syntax-prosody correspondence constraints, which ask that particular syntactic constituents line up with or “match” particular prosodic units, and (ii) prosodic markedness constraints, which place demands on the shape of prosodic structure, irrespective of the syntax. To take a specific example of a match constraint, Selkirk (2011b) uses the constraint MATCH-CLAUSE, which requires that a clause in the syntax correspond to an intonational phrase in the prosody. Other match constraints enforce correspondence at lower levels of syntactic and prosodic structure. By contrast, prosodic markedness constraints are a more heterogeneous class, and could include general constraints against structure-building (e.g. *INTP) and constraints penalizing cross-linguistically marked prosodic structures (e.g. non-binary structures where one prosodic unit only contains a single sub-unit, or recursive structures where one prosodic unit is embedded within another unit of the same level in the hierarchy).

These two families of constraints aim to be able to derive the prosody of all-new sentences where no element receives contrastive stress. To deal with the additional effects of focus and givenness on phrasing, a wide range of additional mechanisms have been proposed by authors including Selkirk (1984, 1995, 2002, 2008), Truckenbrodt (1995, 1999), Schwarzschild (1999), Büring (2006, 2012), Féry and Samek-Lodovici (2006) and Wagner (2006b). Unlike the general syntax-prosody and markedness constraints, which are intended to be universal, the mechanisms for marking focus

and givenness may differ from language to language. As Selkirk (2011a, 2011b: §3.4) observes, not all languages mark focus via prominence, and the question of how discourse-given material is marked cross-linguistically remains largely unaddressed.

For the effect of English alternative-generating focus on prosody, I adopt Truckenbrodt's (1995: 160) constraint FOCUS-PROMINENCE, which has reappeared in various forms many times over the years, and is given in (22) below.¹⁵ It should be emphasized that FOCUS-PROMINENCE is best understood following Selkirk (2011a, 2011b) as an English-specific morphological principle for how alternative-generating focus is realized, rather than a universally attested principle of syntax-phonology interface.

(22) FOCUS-PROMINENCE

A focus (XP_F) contains the maximal prominence within its focus domain.

Truckenbrodt's FOCUS DOMAIN, following Rooth (1992: 114), is the semantic scope at which the focus' alternatives are bound. Under Rooth's system, this is called the SCOPE of the focus, and is encoded structurally by the position of the \sim operator. On the topic abstraction account then, both CT and Exh phrases will have the entire sentence as their focus domain, since this is where the \sim binding them takes scope.

With these pieces in place (match constraints, prosodic markedness constraints and FOCUS-PROMINENCE), can we now predict the location of the CT boundary? Unfortunately, the answer is still no. To see why, consider the following pair, where the CT remains in situ:

¹⁵I believe the name "FOCUS-PROMINENCE" is due to Büring (2006: 338), although his implementation is slightly different, requiring that a prosodic category C containing a focused constituent be the head of the smallest prosodic unit containing C. Féry and Samek-Lodovici (2006) use the name STRESS-FOCUS and are faithful to Truckenbrodt's formalization.

erator and its associate directly. In particular, given the desired outputs in (24), it appears that we would like to enforce the generalization that a CT phrase is realized in the same intonational phrase as its associated CT operator.

- (24) a. I gave [FRED]_{CT} ... [the BEANS]_{Exh}.
 L+H* L-H% H* L-L%
- b. I gave [FRED]_{Exh} [the BEANS]_{CT} ...
 H* L- L+H* L-H%

If we can guarantee that the CT operator and its associate occur within the same intonational phrase, then we gain an explanation of two facts. First, we get an explanation of the basic fact that the CT boundary tone is always at the end of the IntP containing the CT phrase (without tying the boundary tone’s position to the CT phrase directly as Büring does). Second, we get an explanation of the phrasing asymmetry between CT+Exh and Exh+CT. Specifically, the prediction is that while CT+Exh can be realized as two IntPs, Exh+CT must be realized as one. While careful empirical work is needed to test the robustness of this asymmetry, I take the prediction to be a desirable one, as it captures the judgments of boundary strength recorded in the prosodic literature to date—see Pierrehumbert and Hirschberg (1990: ex. 33) and Steedman (2000: ex. 4, 2008: ex. 34b).¹⁶ Note also that while the first of these facts could potentially be captured through an agreement-based account whereby the CT boundary is spelled out directly on the CT phrase, the second fact would go unexplained (unless the agreement relation is subject to prosodic restrictions).

¹⁶See section §5.8 for further discussion of the supposed phrasing asymmetry, and of what kind of evidence would be needed to argue conclusively that such an asymmetry exists.

5.4 Scope-Prosody Correspondence

5.4.1 The SPC Constraint

The new constraint in (25) states the observed prosodic restriction on structures containing a CT operator and its associate. Importantly, here and throughout, we understand “the phrase it associates with” to mean the syntactic object that moves (potentially covertly) to the CT operator position.

(25) Scope-Prosody Correspondence (SPC) (CT version)

The CT operator and the phrase it associates with are realized in the same intonational phrase.

As it stands, this constraint only targets contrastive topics. However, I have named the constraint after Hirotsu’s (2005: 256) more general constraint, which is formulated as follows:

(26) Scope-Prosody Correspondence (SPC) (Hirotsu 2005: 256)

When a term X requires a c-commanding licenser Y, X should be contained in the same Major (phonological) Phrase as Y.

On Hirotsu’s analysis, the SPC constraint regulates the phrasing of a number of constructions in Japanese, including the phrasing of *wh*- questions and the phrasing of sentences containing negative polarity items, quantifiers, and long-distance reflexive anaphors. In seeing whether this constraint could be active in English, the first stumbling block is the use of the prosodic category “Major Phrase”, since it isn’t clear whether this has any direct correspondent in the prosodic hierarchy for English. Ito and Mester (2007, 2013) claim that major phrases as they are used in the analysis of Japanese can be recast as maximal phonological phrases, so this is the most likely equivalence. However given our CT-specific constraint in (25), it seems that if a general constraint like Hirotsu’s were to be applied to English, we would want it

to refer to intonational phrases rather than any kind of phonological phrase as the relevant level of prosodic structure.

Whether a general constraint of this sort could be motivated for English is an important question for future research. To a first approximation, it appears that we can't maintain such a strong claim across the board. In the following example, for instance, the pronoun in the predicate is bound by the subject across an intonational phrase boundary. So at a minimum, we would have to explain why this case is an exception, or what constraint overrides SPC here.

(27) (Every sensible person likes cats.)

[Anyone who DOESN'T like cats]_i ... should have his_i HEAD examined.
 L+H* L-H% H* L-L%

For the time being, I will leave this larger question unanswered, and simply retain the name "Scope-Prosody Correspondence" both as an indication of our constraint's heritage, and as a reminder of the hope of generalizing to a wider empirical domain.

Beyond Hirotani's work on Japanese, scope-prosody correspondence constraints have been called on to explain the phrasing of wh- questions in the work of Ronat (1984) for French, Broderick (1996) for English, Smith (2005, 2011) for Fukuoka Japanese, and Richards (2010) for Japanese, Basque, Tagalog and Chichewa. Still, the use of scope-prosody constraints is relatively uncommon, and one would like to see a larger range of phenomena (beyond wh- movement) implicating their use. English contrastive topic appears to be one such phenomenon.

5.4.2 SPC vs. Focus-Prominence

Let's now see how the scope-prosody correspondence (SPC) constraint allows for an account of where the CT boundary L-H% surfaces. The account is couched in Prince and Smolensky's (1993/2002/2004) optimality theory (OT), where a set of ranked violable constraints determines which of various candidates is the optimal

realization of an underlying form. The core constraints we will use are just those that have been mentioned above: SPC and FOCUS-PROMINENCE. The basic idea is that the phrasing of sentences with CT is governed by the conflicting desires of these two constraints. On the one hand, SPC pushes for integrated phrasings, so the CT phrase and operator can be realized within a single prosodic domain. On the other hand, FOCUS-PROMINENCE pushes for *extra* prosodic breaks, to allow different foci to each be maximally prominent. Before we see the system in action, a few words about each constraint are in order.

The SPC constraint, despite referring to the position an element takes scope, is a constraint on surface pronunciations. On the copy theory of movement, this would mean that the constraint makes reference to whichever copy of the movement chain is eventually spelled out. This type of model has the interesting consequence that whether SPC is satisfied can depend on whether movement is overt or covert. Indeed, Richards (2010) aims to use SPC to predict which copy in a *wh*- movement chain will be pronounced, deriving whether a language's *wh*- phrases move or remain in situ. I explore the idea of using SPC as an impetus for movement further in section §5.7. But to keep things simple, we'll assume for now a traditional inverted Y model where syntactic decisions have already been made before the phonological system has any say.

Truckenbrodt's (1995: 160) FOCUS-PROMINENCE constraint requires that a focus phrase be maximally prominent within its focus domain. Here, we need to be explicit about what counts as maximal. Specifically, if two elements are equally prominent, can they both count as maximal? Let's take the view that maximality can be shared

by more than one focus.¹⁷ The following rewording of FOCUS-PROMINENCE makes it clear that more than one maximum is allowed:¹⁸

(28) FOCUS-PROMINENCE (FP) (“ties satisfy” version)

A focus (XP_F) contains a prominence at least as great as any other within its focus domain.

The tableau in (29) shows a first example of the constraint system at work. The input in the upper left is the structure that the topic abstraction model posits for the sentence “I gave [Fred]_{CT} [the beans]_{Exh}”. The candidates (a) and (b) are possible phrasings of the sentence, shown as metrical grids. The symbols ϕ and ι are short-hands for the prosodic units phonological phrase (PhonP) and intonational phrase (IntP) in the prosodic hierarchy. An ‘×’ marks the head of a prosodic domain. Thus in candidate (a) the prosodic words *Fred* and *beans* are each the head of a PhonP, and the latter PhonP is head of the IntP containing the entire sentence.

¹⁷This “ties satisfy” view of maximality is also the understanding of focus prominence advocated by Féry (2007: 78–79), who uses a constraint STRESS-TOPIC to ensure that a topic be at least as prominent as anything else within a particular domain.

¹⁸This version of FOCUS-PROMINENCE may be too weak in cases of a single F-marked phrase. Katz and Selkirk (2011) show that English contrastive foci (which I take to bear an alternative-generating F-mark) receive a greater prominence than discourse-new elements (which I take to lack F-marking). To enforce the asymmetry between contrastive and information focus while retaining the possibility of two F-marked phrases sharing the title of “maximum”, we could phrase FOCUS-PROMINENCE as follows: For a given focus domain, all foci (XP_F) having that domain must be more prominent than other material in the domain (but the foci themselves may be equally prominent).

(29)

	\sim \uparrow CT- λ I gave [Fred] _F [the beans] _F }	SPC	FP
a.	$($ $($ \times $)$ $($ \times $)$ $)$ ι ϕ		*!
☞ b.	$($ \times $)$ $($ \times $)$ $)$ ι ϕ		

The desire of the SPC constraint is that the phrase moving covertly to the CT position (in this case, *Fred*) surface in the same IntP as the CT operator. This demand is met in both candidates, so the constraint has no preference between them. However FOCUS-PROMINENCE (FP) does have a preference. This constraint asks that each focus phrase be maximally prominent within its focus domain. Since the alternatives of the two foci are bound by the same wide-scoping \sim operator, they share the entire sentence as their focus domain. Thus, FP requires that each focus be as prominent as anything else in the sentence, including each other. Candidate (a) violates this constraint since the focus [Fred]_F is less prominent than [the beans]_F. This is illustrated by the violation mark (*) under FP. Since candidate (a) performs strictly worse on our constraints (technically it’s “harmonically bounded”), this violation is fatal (marked by ‘!’), and the optimal candidate is (b), regardless of the constraint ranking.¹⁹

In a moment we’ll look at how the winning candidate (b) is pronounced. But first, it’s worth mentioning a potential worry about the claim that (b) does in fact satisfy FOCUS-PROMINENCE. One concern for this “maximal by tie” view is the implications it has for higher levels of phrasing. On the standard conception of prosodic structure advanced by Selkirk (1996), even a single-syllable utterance will project a full prosodic structure that realizes all levels of the prosodic hierarchy:

¹⁹To be sure, other constraints may prefer candidate (a). For instance, the structure-building constraint *INTP, as used by Féry (2007), prefers having one IntP to having two. Since (b) wins, we can infer the ranking FP \gg *INTP. More generally, if FOCUS-PROMINENCE is the only reason that this input would be phrased as two intonational phrases, then FP must outrank any constraint preferring (a) over (b).

syllable, foot, prosodic word, phonological phrase, intonational phrase, and utterance phrase (UttP). If the two intonational phrases in (b) are in fact contained within a larger utterance phrase, the question arises as to what the head of this UttP is. If utterance phrases are uniquely headed, which is commonly assumed to be the case for all prosodic domains (as proposed by Selkirk 1996, although see Katz and Selkirk 2011 for a different view), then inevitably one of the intonational phrases will be more prominent than the other, and the two foci will no longer both count as maximal. There are a number of potential responses to this worry, and I invoke them collectively without deciding between them here. One approach is to rank FP above the relevant prosodic markedness constraints, so that a “degenerate” prosodic structure is allowed. Depending on the constraints chosen, we could allow for an UttP with two heads, or no heads, or even for the possibility that no UttP is projected at all. Another approach would be to question whether headedness is in fact active at the level of UttP in the first place. Especially if we consider multi-sentence utterances, it becomes unclear whether there are good reasons for treating one sentence as a head and the others as subordinate. In any case, I will ignore phrasing above the IntP in what follows, and so retain the option of shared maximality of two IntP heads.²⁰

How will the winning candidate (b) be realized in terms of an intonation contour? Recall our assumption that the CT operator is lexicalized as L-H%. This tonal morpheme is specified to occur at the right edge of an intonational phrase, so it will surface at the nearest such boundary—specifically, after *Fred*. I assume that the head of a PhonP is realized in English via a pitch accent.²¹ Thus, both *Fred* and *beans* will

²⁰Given the option of shared maximality, another candidate for (29) would project a PhonP for each pitch accent, but fail to project an IntP at all. Katz and Selkirk (2011) put this type of structure to use in accounting for all-new sentences, which they show to bear less prominence than sentences with an alternative-generating focus. Since my examples all involve alternative-generating focus, I assume that this less-prominent phrasing won't be available, although I don't account for this formally.

²¹Beckman and Pierrehumbert (1986) make essentially the same assumption, requiring that a PhonP contain one or more pitch accents.

bear pitch accents. Finally, following Beckman and Pierrehumbert (1986), I assume that every phonological phrase is marked by a phrase tone (L- or H-) and that every intonational phrase is marked by a boundary tone (L% or H%).²² Thus, the second IntP’s right edge will also receive a phrase and boundary tone.

Already, we are most of the way to the desired ToBI specification for the sentence. What’s missing is any prediction about the shape of the pitch accents, and the particular choice of the sentence-final tones. For the time being, let’s assume that these are inserted by default. I will return to the issue of pitch accent shape in section §5.9. With these last pieces in place, we have the contour as follows:

$$(30) \quad \text{I gave } [\text{FRED}]_{\text{CT}} \dots [\text{the BEANS}]_{\text{Exh}}.$$

$$\qquad \qquad \text{L+H* L-H\%} \qquad \qquad \qquad \text{H* L-L\%}$$

So far, we’ve derived the fact that CT+Exh examples are phrased as two intonational phrases, with the L-H% boundary between the two foci. Let’s now compare CT+Exh with Exh+CT to see how SPC distinguishes between the two orders. Tableaux for CT+Exh and Exh+CT are given in (31) and (32).²³ The tableau in (31) is identical to (29) above, except that I have employed a shorthand for describing the input. Rather than showing the covert movement with an arrow, I have indicated which focus is CT and which is Exh with the subscripts $[\cdot]_{\text{CT}}$ and $[\cdot]_{\text{Exh}}$. Crucially, these marks are not visible to the phonology, which simply sees the phrases as F-marked.

²²Beckman and Pierrehumbert use the term “intermediate phrase” instead of “phonological phrase”.

²³I’ve left out the squiggle operator in the input to this and following tableaux.

(31)	CT-λ I gave [Fred] _{CT} [the beans] _{Exh}	SPC	FP	CT+Exh
a.	(×) _t (×) _φ		*!	
☞ b.	(×) _t (×) _φ			

(32)	CT-λ I gave [Fred] _{Exh} [the beans] _{CT}	SPC	FP	Exh+CT
a.	(×) _t (×) _φ	*!		
☞ b.	(×) _t (×) _φ		*	

The candidates in (32) are the same as before: either the sentence is parsed as two intonational phrases or as one.²⁴ However in Exh+CT order, the scope-prosody correspondence constraint no longer sees the candidates as equal. Here, SPC wants the CT operator and its associate [the beans]_F to occur in the same IntP. Since the exhaustive focus [Fred]_F intervenes between the operator and its associate, there is no way to parse the sentence as two intonational phrases without violating SPC. Thus, in Exh+CT examples there is a conflict between SPC, which prefers a single IntP, and FP, which prefers two. Since the winning candidate is the one with a single IntP, we have evidence for ranking SPC ≫ FP. (This ranking is indicated by the now solid line separating the SPC and FP columns.)

The winning candidate (32b) contains only a single intonational phrase, so the CT operator is predicted to encliticize to this final position. Since the sentence-medial boundary is only a PhonP break, we predict the appearance of a phrase tone, but no boundary tone. Once again, we are most of the way to the ToBI contour for the entire sentence, as shown in (33). And again, I assume that the missing pieces (the

²⁴I've limited attention here and throughout to candidates where every prosodic unit has a unique head. For constraints that can be used to encode this restriction as part of the grammar, see Selkirk 1996.

particular choices of pitch accents and L- as the sentence-medial phrase tone) will be inserted by default, although see section §5.9 for more discussion of this point.

(33) I gave [FRED]_{Exh} [the BEANS]_{CT} ...
 H* L- L+H* L-H%

At the point, we've seen how topic abstraction structures can be translated into prosodic contours under an optimality theoretic framework. Beyond the constraints commonly assumed to govern the syntax-phonology interface, we made crucial use of a scope-prosody correspondence constraint, in the spirit of Hirotsu (2005). This constraint is what gives the phonology access to the otherwise hidden information of where a particular F-marked phrase is interpreted in logical form.

What we've shown so far is that the account can deal with the most basic cases of CT+Exh and Exh+CT. One advantage over previous accounts was already evident. Namely, we're capturing what appears to be a real asymmetry between CT+Exh and Exh+CT in terms of phrasing. However, we can't be too excited about this first advantage yet. While this prediction is in line with various judgments in the literature (Pierrehumbert and Hirschberg 1990: ex. 33 and Steedman 2000: ex. 4, 2008: ex. 34b), careful experimental work remains to be done to test the robustness of the asymmetry.²⁵ In lieu of a final verdict on this empirical question, we should take a closer look at the other places where the predictions of this model diverge from previous accounts. The next section addresses three cases of such divergence.

5.5 Delayed Boundaries

Across a range of examples, the CT morpheme L-H% surfaces in a position other than directly marking the CT phrase. This fact is challenging for theories that treat

²⁵See footnote 9 for some potential support from experiments by Liberman and Pierrehumbert (1984), and section §5.8 for further discussion.

CT morphology as stemming from CT phrase itself. In this section, I discuss three cases where the CT boundary can or must be delayed. We'll see that in each case, the SPC-based model is able to account for the position of the delayed boundary. First, we'll discuss lone CT and Exh+CT examples where the CT phrase is sentence-medial but the rising CT boundary is sentence-final. Second, we'll see that when CT appears island-medially, the CT boundary is delayed until an island-final position. Finally, we'll discuss variability in CT boundary placement in CT+Exh examples where the two focused phrases are non-adjacent.

5.5.1 Sentence-Final L-H%

Our account of the CT+Exh and Exh+CT facts easily extends to lone CT sentences. For example, in (34), there is no pressure from FOCUS-PROMINENCE to create an IntP break, so the sentence can be phrased as a single IntP, and SPC will be trivially satisfied. And if we only have one IntP, then the rising CT clitic will necessarily surface sentence-finally.

(34) I gave [FRED]_{CT} something...
 L+H* L-H%

Since FP and SPC are indifferent to whether a structure like (34) is realized as one IntP or two, we can assume that the choice falls to general prosodic markedness constraints. For simplicity of exposition, I will use the following *INTP constraint to prefer phrasings with less IntP breaks.

- (35) *INTP (Féry 2007)
 No intonational phrase. (Each incurs a penalty.)

With this constraint against structure-building in place, we can understand the fact that (34) is squeezed into a single IntP as a matter of default. All else being equal, the grammar will select the phrasing with less structure. This preference is illustrated in the following tableau:

(36) Lone CT

	CT-λ I gave [Fred] _{CT} something	SPC	FP	*INTP
☞ a.	(×) _ι (×) _φ			*
b.	(×)(×) _ι (×)(×) _φ			**!

Alternatively, we could do without *INTP, and see the problem with candidate (b) in terms of an independent conflict that arises once a second IntP is created. For one, this phrasing is in violation of Selkirk’s (2011b) MATCH-CLAUSE constraint, requiring that every intonational phrase correspond to a syntactic clause. A further problem is that according to the general principle of HEADEDNESS (Selkirk 1996), an IntP must contain a head PhonP, and a PhonP must in turn contain a head prosodic word. Thus the second IntP must contain a prominent word, which as the head of an IntP will receive a pitch accent. The resulting conflict is that the word *something*, which is intended as given in the context, will be forced to bear a pitch accent. This is a violation of the general principle that given material is prosodically non-prominent (cf. Féry and Samek-Lodovici’s 2006 DESTRESS-GIVEN). Thus, even in the absence of *INTP, any candidate that realizes (36) as two intonational phrases would have an unnecessary violation of either HEADEDNESS or DESTRESS-GIVEN.

Regardless of the details of how the second IntP is ruled out, the general prediction is that any sentence where the last focal element is a CT will be realized with L-H%

sentence-finally. Thus, not only lone CT, but also Exh+CT should display sentence-final L-H% at a distance from the CT phrase. This is confirmed in examples like the following:

- (37) [NOBODY]_{Exh} gave [FRED]_{CT} anything...
 H* L- L+H* L-H%

5.5.2 Island-Internal CT

Recall the contrast in (38), which is unexpected on CT-marking theories like Büring 2003. On Büring’s view of the interface, the L-H% boundary tone directly marks the CT phrase. Thus, as it stands, the model predicts the opposite of the attested judgments. The observed fact is that the CT boundary resists marking an island-internal CT phrase locally, and rather is delayed until the island edge.

- (38) (What about Mary and Fred? Did *they* bring anything tasty?)
- a. The dish that [MARY]_{CT} brought ... was [SUPERB]_{Exh}.
 L+H* L-H% H* L-L%
- b. *The dish that [MARY]_{CT} ... brought was [SUPERB]_{Exh}.
 L+H* L-H% H* L-L%

There are various ways that a Büring-style model could be adapted to handle this fact. One approach would be to insist that the pronunciation in (38a) is actually the realization of a different structure, where the entire subject has been CT-marked, and thus the L-H% boundary directly marks the CT phrase:

(39) [The dish that MARY brought]_{CT} ... was [SUPERB]_{Exh.}
 L+H* L-H% H* L-L%

This choice of a broader CT will result in a strictly less informative utterance (compatible with a wider range of discourse strategies), so the prediction is that broad CT as in (39) will be congruent with all the contexts where narrower CT would be, and more. One question for this explanation is whether general Gricean principles would rule out the use of the less informative utterance in a context where the more informative one is appropriate. However even if this concern can be put to rest, there is a remaining problem. Why is (38b) ruled out? Even if broad CT is possible in this context, why should narrow CT marking on *Mary* be impossible? Here, there is no reason why a system that interprets CT in situ would disallow marking CT island-internally, and a stipulation against such marking would be suspicious. Indeed, why should islands be implicated if there is no movement at play?

On the SPC-driven account, the contrast in (38) is captured automatically. Recall that SPC places a prosodic demand on the syntactic constituent undergoing (potentially covert) movement to the CT operator position. As we saw in section §3.4, there is independent reason to believe that this movement respects islands, even in the case that the movement is covert. Specifically, CT is disallowed inside islands that also contain an exhaustive focus. We understood the related fact that CT *can* appear alone inside an island in terms of pied-piping. In this case, our analysis was that the entire island moves covertly to the operator position.

Based on these findings, the only viable analysis of (38a) is one in which the entire island associates with the CT operator, as shown in (40). Since SPC requires that the entire moving constituent be realized within the same IntP as the CT operator, candidates like (a) that place an IntP break island-internally are inferior to the optimal candidate (b) where the IntP break coincides with the island edge. As before,

FOCUS-PROMINENCE rules out the possibility of a CT+Exh example being realized as a single IntP, as in (c).

(40)

	CT-λ [the dish that [Mary] _F brought] was [superb] _F	SPC	FP
a.	(×)(×) _ι (×)(×) _φ	*!	
b.	(×)(×) _ι (×)(×) _φ		
c.	(×)(×) _ι (×)(×) _φ		*!

Note that this analysis predicts that (38a) and (39) will have the CT boundary in the same position, despite the difference in the size of what is semantically the CT (i.e. the size of the F-marked constituent). Thus, there is no need to stipulate any restriction against marking narrow CT within an island. If these two forms (narrow and broad CT) sound the same,²⁶ we have no direct source of evidence as to which one we are hearing. It is an interesting question for future work whether there could be indirect evidence showing that only one of the two structures is available in a particular context. My assumption here has just been that narrow CT within an island is not blocked across the board on semantic grounds.

5.5.3 Constrained Variability

The previous two sections dealt with cases where the CT boundary *must* be pronounced at a distance from the CT phrase itself. What about cases where delaying the CT boundary is optional? Recall the following facts, where those speakers who

²⁶To fully derive the homophony of (38a) and (39), we actually need to do a bit more work. In the case of (39), there are various options for positioning the pitch accent within the subject ‘the dish that Mary brought’. Here, we can invoke a system like Selkirk’s (1995) that disallows given material from receiving an accent to explain why broad focus in (39) results in a prominence on *Mary*.

accept (41b) are reproducing judgments reported by Rooth (2005: ex. 10c) and Steedman (2008: ex. 34a):

(41) (What about FRED? What did HE eat?)

- a. $[\text{FRED}]_{\text{CT}} \dots \text{ate} [\text{the BEANS}]_{\text{Exh.}}$
 $\text{L+H}^* \text{ L-H}\% \qquad \qquad \text{H}^* \text{ L-L}\%$
- b. $\%[\text{FRED}]_{\text{CT}} \text{ate} \dots [\text{the BEANS}]_{\text{Exh.}}$
 $\text{L+H}^* \qquad \text{L-H}\% \qquad \qquad \text{H}^* \text{ L-L}\%$

The ‘%’ sign marks (41b) as accepted by many but not all speakers. Concentrating for the moment on those who accept the sentence, how should we model this optionality? In fact, the account developed above puts us in a good position to do so. As the following tableau shows, the constraints we’ve been working with so far don’t distinguish between (41a) and (41b):²⁷

(42)

CT- λ [Fred] _{CT} ate [the beans] _{Exh}	SPC	FP
a. $(\quad \times \quad) (\quad \times \quad)_{\iota}$ $(\quad \times \quad) (\quad \times \quad)_{\phi}$		
b. $(\quad \times \quad) (\quad \times \quad)_{\iota}$ $(\quad \times \quad) (\quad \times \quad)_{\phi}$		

In the absence of other constraints, the grammar predicts that the two candidates are equally optimal, and thus should both be possible pronunciations. However, there are surely constraints that do distinguish between the two forms. One such constraint is Selkirk’s (2011b) MATCH-PHRASE, which asks that syntactic phrases correspond to phonological phrases and vice versa. This constraint will prefer candidate (a), where the PhonP break aligns with the boundary of the VP ‘ate the beans’. If nothing overrules MATCH-PHRASE’s preference for (a), we predict speakers will reject (b).

²⁷The input to the tableau assumes that no overt topicalization has taken place, although this is not ascertainable from the word order or pronunciation. In any case, overt movement of *Fred* to the CT operator position won’t affect how the constraints behave.

Some speakers do exhibit exactly this behavior. But what about the speakers Rooth and Steedman report, who accept both forms?

I'd like to offer a crude solution. In (43), I introduce the new constraint *SUSPENSE*. The idea behind this constraint is that a speaker may choose to insert a pause before the constituent that answers the question under discussion, for rhetorical effect.

(43) *SUSPENSE*

A sentence-final exhaustive focus is preceded by an IntP break when the speaker wants to convey suspense.

Consider the effect of *SUSPENSE* on the sentence in (44). The typical rendition in (a) only has a single pitch accent on *Mary*. This is expected, since only *Mary* is focused, and the rest of the sentence is given in the context. However a more theatrical rendition as in (b) is also possible, where the sentence is realized as two intonational phrases, and the copula bears a pitch accent. Despite performing worse on a host of constraints (**INTP*, *DESTRESS-GIVEN*, *MATCH-PHRASE*),²⁸ this candidate satisfies *SUSPENSE*, so we can capture its optimality if *SUSPENSE* is ranked high enough.

(44) (Who's the winner?)

- a. The winner is [MARY]_{Exh}.
- b. The winner IS ... [MARY]_{Exh}!

Returning to (41), if we rank *SUSPENSE* \gg *MATCH-PHRASE*, the prediction is that the delayed form (41b) will be possible just in case the speaker wishes to convey suspense (assuming for the time being the absence of other constraints that would prefer this form). Furthermore, since *SUSPENSE* is sensitive to the size of the focus-marked phrase, we predict that delaying the boundary to the point where it encroaches

²⁸The extra violation of **INTP* is due to the rising IntP break after 'is'. The violation of *DESTRESS-GIVEN* is due to the accent of 'is', despite its being given in the context. The violation of *MATCH-PHRASE* is due to the failure of VP to correspond to a PhonP.

on the exhaustive focus will be impossible. This second prediction is confirmed in the broad VP focus data we saw in section §5.1, repeated here:

(45) (What about FRED? What did HE do?)

- a. [FRED]_{CT} ... [ate the BEANS]_{Exh}.
 L+H* L-H% H* L-L%
- b. # [FRED]_{CT} [ate ... the BEANS]_{Exh}.
 L+H* L-H% H* L-L%

Finally, as predicted by the “sentence-final” stipulation, it appears that this variation is restricted to cases where the exhaustive focus is sentence-final:

(46) (What about FRED? Who does HE tell his troubles to?)

- a. [FRED]_{CT} ... tells [MARY]_{Exh} his troubles.
 L+H* L-H% H* L-L%
- b. ?? [FRED]_{CT} tells ... [MARY]_{Exh} his troubles.
 L+H* L-H% H* L-L%

The use of SUSPENSE is one way of capturing the variability of delayed CT boundaries. More work remains to be done to determine precisely what factors control the choice to delay, and whether the effect is always stylistic or sometimes conveys a semantic effect.²⁹ However, regardless of the particular implementation, the variability data make it clear that we need to allow for flexibility in where the CT boundary goes. The important point is that our model of CT doesn’t impose a fixed position for the CT boundary, and thus leaves room for other factors to affect its positioning.

²⁹Another factor that may create pressure to delay the CT boundary is the desire to avoid having a prosodic constituent begin with a relatively weak prosodic element. This is encoded by the STRONG-START constraint motivated by Selkirk (2011b) and Elfner (2012).

5.6 Multiple CT

In this section, we turn to the realization of examples involving more than one CT phrase. As we saw in section §3.5, these fall into two semantic categories. First, we have examples of what I've called **COMPLEX CT**, where a single CT operator binds multiple CT phrases, as in (47). Second, we have examples of **NESTED CT**, involving multiple CT operators, as in (48).

(47) (What did Fred and Mary give each other?)

[FRED]_{CT} gave [MARY]_{CT} ... [a UKELELE]_{Exh.} **Complex CT**
 L+H* L- L+H* L-H% H* L-L%

(Mary gave Fred ... a tie.)

(48) (What about Fred and Sue? What did they give everyone?)

[FRED]_{CT} ... gave [MARY]_{CT} ... [a UKELELE]_{Exh.} **Nested CT**
 L+H* L-H% L+H* L-H% H* L-L%

(And he gave Bill a kite. Sue ... gave John a tie and Ann a hat.)

We'll now look at these two classes of multiple CT in turn, and see how their prosody can be derived using the SPC-driven model described above.

5.6.1 Complex CT

The clearest cases of complex CT are those where two CT phrases occur together within an island, as in (49). As we saw in section §3.5, the topic abstraction account (like other movement-based accounts of CT) implies that such examples can't involve movement of the CT phrases to separate operator positions. Rather, CTs occurring within the same island must be bound by the same CT operator. This is achieved by covertly or overtly CT raising the entire island structure as in (50).

Sentences lacking an exhaustive focus work similarly. For example, in (53) the island-internal CTs must be phrased together as in (a), rather than separated by an IntP as in (b).

(53) (The poem Mary wrote Fred isn't good enough. Are there any other poems?)

- a. There's the poem $[\text{FRED}]_{\text{CT}}$ wrote $[\text{MARY}]_{\text{CT}}$...
 $\text{L+H}^* \text{L-}$ $\text{L+H}^* \text{L-H}\%$
- b. ??There's the poem $[\text{FRED}]_{\text{CT}}$... wrote $[\text{MARY}]_{\text{CT}}$...
 $\text{L+H}^* \text{L-H}\%$ $\text{L+H}^* \text{L-H}\%$
- c. \sim \uparrow CT- λ there is $\underbrace{[\text{the poem } [\text{Fred}]_{\text{F}} \text{ wrote } [\text{Mary}]_{\text{F}}]}$

The analysis of (49) and (53) as complex CT is already forced by the topic abstraction account. However it is welcome support that the LFs we're positing lead directly to the right predictions about how these examples will be phrased.

In cases where multiple CT phrases occur *outside* of any island, there is no reason to think that the syntax would prevent them from raising to distinct operator positions to produce a nested CT configuration. However, we saw some initial evidence in section §3.5 that a complex CT configuration should be possible here as well, and may even be preferred in some contexts. For example, in a case like (54), there appears to be no sorting of giver over recipient or vice versa, suggesting that neither CT out-scopes the other. A simple way to capture this lack of sorting is with the structure in (55), where the two CTs raise to the same operator position:³¹

³¹See section §3.5 for discussion of how such a structure could be interpreted.

(54) (What did Fred and Mary give each other?)

[FRED]_{CT} gave [MARY]_{CT} ... [a UKELELE]_{Exh.} (Mary gave Fred ... a tie.)
 L+H* L- L+H* L-H% H* L-L%

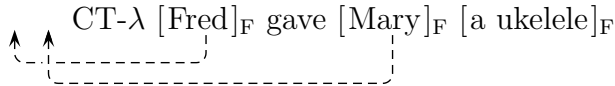
(55) ~ 

Here again, the SPC constraint demands that the two CT phrases be realized within a single IntP. While the two CTs don't raise *together*, they nevertheless raise to the same operator position. Since SPC requires that each CT phrase occur within the same IntP as this single operator, the two phrases will necessarily share a single IntP.

Our initial arguments from section §3.5 for treating (54) as a case of complex CT were fairly weak. The main point was that nested CT semantics would be “overkill” in the sense of encoding that one CT out-scopes the other in a context where this sortal distinction is vacuous. However we are now seeing the beginning of a second argument, rooted in the prosody. In a context like (54) where sorting one CT over the other would be useless, we find the two CTs are phrased together, as predicted if there is only one operator binding them. To the degree that this is the only phrasing possible (which is an open empirical question), and to the degree that nested CT would be phrased otherwise (as we will see shortly), we have reason to believe that (54) is indeed a case of complex CT.

As before, the same basic pattern is observable in the absence of an Exh phrase. For example, in (56)—another context forcing complex CT—the generalization holds that the two CTs will be phrased within one IntP. Furthermore, in this case, there is a relatively clear judgment that a full IntP break is strange.

(56) (Does Fred like Mary?)

- a. [MARY]_{CT} likes [FRED]_{CT} ...
L+H* L- L+H* L-H%
- b. ??[MARY]_{CT} ... likes [FRED]_{CT} ...
L+H* L-H% L+H* L-H%

5.6.2 Nested CT

Nested CT structures involve more than one CT operator, each associating with its own CT phrase. If the CT operator is lexicalized as L-H%, as hypothesized above, then we expect that a nested CT sentence will exhibit multiple realizations of the L-H% morpheme. This expectation is largely borne out, although we will see one potential exception below.

The clearest cases of nested CT are topicalization structures like the ABC diet examples from section §3.1.5, repeated here:

(57) (On my new diet, every day I eat one avocado, one burrito and one cheesecake.)

- a. On [SUNDAYS]_{CT} ... [the BURRITO]_{CT} ... I have for [LUNCH]_{Exh}.
L+H* L-H% L+H* L-H% H* L-L%
- b. The [BURRITO]_{CT} ... [on SUNDAYS]_{CT} ... I have for [LUNCH]_{Exh}.
L+H* L-H% L+H* L-H% H* L-L%

Recall that we have good reason to believe that (a) and (b) evoke nested CT meanings, since they are licensed in different contexts. Specifically, they seem to demand continuations that “sort” the first CT over the second:

- (58) On [SUNDAYS]_{CT} ... [the BURRITO]_{CT} ... I have for [LUNCH]_{Exh}.
 L+H* L-H% L+H* L-H% H* L-L%
- a. And the AVOCADO ... I have for DINNER.
- b. ??And on MONDAYS ... I have (it) for DINNER.
- (59) [The BURRITO]_{CT} ... on [SUNDAYS]_{CT} ... I have for [LUNCH]_{Exh}.
 L+H* L-H% L+H* L-H% H* L-L%
- a. And on MONDAYS ... I have for DINNER.
- b. ??And the AVOCADO ... I have for DINNER.

To account for this distributional asymmetry (in section §3.5), we posited the following nested CT representations for the two sentences:

- (60) a. [on [Sundays]_F] CT- λ_1 [the burrito]_F CT- λ_2 I have t_2 for [lunch]_F t_1
 b. [the burrito]_F CT- λ_1 [on [Sundays]_F] CT- λ_2 I have t_1 for [lunch]_F t_2

As with the complex CT cases, plugging these structures into our OT account immediately gives the desired results. The tableau below illustrates for the case of (60a). Since ‘the burrito’ is dislocated from its base position, I assume that it has undergone overt CT raising. Furthermore, since ‘on Sundays’ surfaces in an even higher position, we can assume that it too has overtly CT raised.³²

³²The parallel assumptions are harder to motivate in the case of (60b). Specifically, there is no obvious reason to rule out the possibility that ‘on Sundays’ surfaces in its base position. If this is the case, it undergoes covert CT raising, and we have to address the issue of why can’t it associate with the higher of the two CT operators. In section §3.5 we considered a stipulation that CT phrases that raise covertly can’t out-scope those that raise overtly. However we will see shortly that our account in terms of SPC allows for a more principled account.

(61)	on [Sunday] _F CT-λ [the burrito] _F CT-λ I have for [lunch] _F	SPC	FP
☞	a. (×) (×) (×) _i (×) (×) (×) _φ		
	b. (×) (×) (×) _i (×) (×) (×) _φ		*!

Since the CTs have raised overtly to their respective operator positions, it is possible for each CT to share an IntP with its associated operator (satisfying SPC) without compromising FOCUS-PROMINENCE, as in candidate (a). According to these constraints, there is no advantage to putting the two CTs in a single intonational phrase.

In fact, beyond its inferiority on the constraints in question, there is another problem with (b). Since there are two CT morphemes L-H% in the input, it is reasonable to expect a preference that each morpheme be realized *independently* in the output. McCarthy and Prince (1995) refer to this constraint against merging two elements of the input as UNIFORMITY. While its effect would be redundant in (61), this constraint will do some work for us shortly.

The analysis we've been considering also points us in the direction of an account of the observation from section §3.1.5 that an overtly moved CT out-scopes a CT left in situ. For example, in (62), the overtly raised 'the burrito' is sorted over the lower CT 'lunch'.

- (62) [The BURRITO]_{CT} ... I have for [LUNCH]_{CT} ... on [SUNDAYS]_{Exh}.
 L+H* L-H% L+H* L-H% H* L-L%
- a. And (I have it) for DINNER on MONDAYS.
- b. ??And (I have) the AVOCADO (for lunch) on MONDAYS.

Given our system of constraints, there is an elegant way of handling this asymmetry; however the solution I have in mind raises a number of larger issues that I won't be able to address fully here. Suppose, following Grimshaw (1997), we assume that the inputs to our OT system are not yet specified for whether movement has taken

place. For our purposes, this assumption means that overt and covert CT raising structures compete as part of the same candidate set. Without any modification to our constraints or their ranking, this assumption leads to the prediction that in certain cases, CT raising will have to be overt—specifically, when overt movement leads to a more harmonic output. To see how this system could help to disambiguate (62), consider the two movement configurations in (63), where solid lines indicate overt movement and dashed lines covert movement.

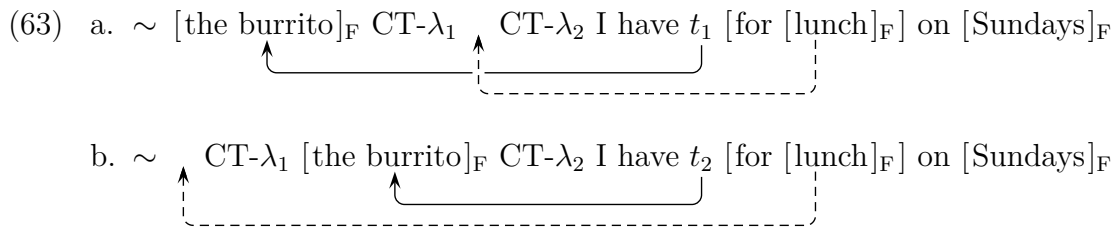

In (a), which corresponds to the attested reading of (62), SPC can be satisfied by spelling out each operator-associate pair as its own IntP, just as (62) is in fact phrased. In (b) however, which encodes the unattested reading, this separation is impossible, since SPC demands that the higher operator share an IntP with the lower CT. In this case, the only way to satisfy SPC would be to violate UNIFORMITY, as in (64a). If we take UNIFORMITY to be highly ranked, this implies that (64a) is not an optimal way of expressing the meaning in (63b). In particular, raising the wider-scoping CT overtly, as in (64b) is preferable.

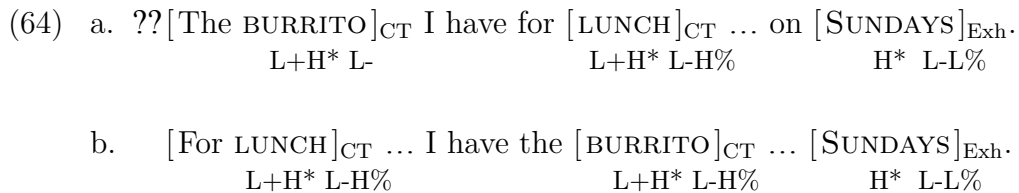

Turning back to (62), we now have an explanation for why the raised CT has to be interpreted as sorted over the one left in situ. If the opposite sorting “lunch over

burrito” had been intended, raising the high-scoping CT overtly would have resulted in a more harmonic realization. Therefore this is not a possible reading.

Adopting this style of OT-driven syntax introduces a number of additional complications. For one, we should consider that there may be a penalty associated with overt movement in the first place. Grimshaw (1997) formalizes this in terms of the constraint STAY, which is violated whenever a phrase moves. Interestingly though, the addition of this constraint doesn’t affect the argument given above concerning (62) and (64). Regardless of how STAY is ranked, the form raising only the higher-scoped of the two CTs will be preferable to the form raising only the lower-scoped one. This is enough to guarantee that (62) only has the desired “surface” reading.

However there are other situations where STAY will make a difference. Consider the various phrasing options for a multiple CT example where both CTs are left in situ, as in (65). Regardless of which CT takes higher scope—the options given in (a) and (b)—there is no way to phrase these structures that respects both SPC and UNIFORMITY. Thus, if STAY is ranked below these constraints, we predict that movement will be unavoidable in nested CT examples.

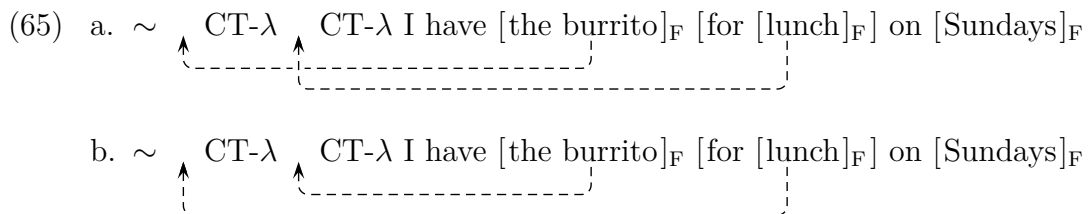

On the other hand, with a ranking of SPC \gg STAY \gg UNIFORMITY, we would predict that nested CT examples require leaving both CTs in situ, and are phrased in a way that makes them indistinguishable from complex CT:

(66) I have [the BURRITO]_{CT} for [LUNCH]_{CT} ... on [SUNDAYS]_{Exh}.
 L+H* L- L+H* L-H% H* L-L%

As it stands, this second option can't be right for English. We've already seen that nested CT examples with movement are possible (as in the ABC examples), and indeed this seems to be their preferred realization. However whether (66) is available as an *alternative* nested CT realization (in addition to its complex CT meaning) is an important remaining question which I will leave open.

Let's take a step back, and see where we stand. The main point about multiple CT is the following. Without any additional constraints, and without moving into the realm of OT-driven movement, the same analysis that captured (i) the phrasing asymmetry between CT+Exh and Exh+CT and (ii) the location of the CT boundary tone immediately carries over to cases of multiple CT. In particular, the account captures several core facts. First, we capture the fact that regardless of how many CTs occur, and regardless of their position, every CT phrase will occur within an IntP that ends with a rising L-H% boundary. This is enforced by the undominated constraint SPC. Second, we capture the difference in how complex CT and nested CT structures are phrased. The broad generalization is that complex CT structures demand phrasings where the CTs share a single IntP, whereas nested CT structures can, in many circumstances, license phrasings where the CTs are separated into distinct IntPs. To make progress on the question of precisely which nested CT configurations allow these distinct phrasings, and what scope readings are available to each form, we moved into less familiar territory. Here, I outlined the potential benefits of transferring our same constraint set over to an OT framework that allows competition between different surface word orders. This move is promising in that (i) it explains the inability of an in-situ CT to out-scope a raised CT, and (ii) it opens up the possibility that some CT configurations require movement. In the next section I consider one more area where

such an analysis could be of use. However a fully explicit account of CT phrasing in this latter framework remains a problem for future research.

5.7 Pressure to Raise

As we just saw, allowing overt and covert movement candidates to compete can result in a pressure to raise the higher-scoped of two CT phrases. In fact, the same analysis would also have consequences for Exh+CT examples like (67a). On this account, the topicalized counterpart in (b) is a competitor, and only one of the two forms should surface.

- (67) a. I gave [FRED]_{Exh} [the BEANS]_{CT} ...
 H* L- L+H* L-H%
- b. [The BEANS]_{CT} ... I gave [FRED]_{Exh}.
 L+H* L-H% H* L-L%

If these realizations are put into competition, the prosodic constraints (SPC and FP) will invariably favor (b), since this form obeys both constraints while (a) violates FP. On the other hand, STAY prefers (a).

For English, the predictions of this type of constraint system are too rigid. To a first approximation, at least, we would like to allow *either* of these forms to surface, and could treat them as in free variation.³³ Formally, this could be achieved by leaving STAY unranked, or allowing stylistic reranking of STAY with respect to the other constraints.

While much remains to be worked out, I would suggest that this type of analysis is on the right track, in that it makes the broad prediction that there will be pressure to raise a CT phrase when doing so results in a better prosodic profile. This could provide an explanation for certain otherwise mysterious facts. First, while Exh+CT

³³See section §3.6 for some potential restrictions on Exh+CT order. But still, in the cases where Exh+CT is licensed, it seems that CT+Exh is available as well, and expresses the same meaning.

order is allowed in English, it seems to generally be dispreferred (cf. Wagner 2012: 23). Second, there are languages that have been described as allowing CT in situ, but only in CT+Exh order, not in Exh+CT order. German is one such language, on the descriptions of Büring (1997b: 65) and Wagner (2012: 9). The basic idea is the same as that proposed by Féry (2007) (for German): raising a contrastive topic to the left periphery can serve a prosodic end, allowing a phrasing that would otherwise be unavailable, separating the CT and following Exh into distinct prosodic domains. Overall, using prosodic constraints like the SPC as an impetus for movement is an exciting prospect, but much remains to be explored.

5.8 The Agreement Alternative

The analysis of English CT prosody presented in sections §5.2–§5.6 was rooted in the assumption that L-H% is the lexicalization of the CT operator. This assumption eventually led us to posit a scope-prosody correspondence (SPC) constraint to help explain the effects of the CT operator on prosodic phrasing and derive the surface position of the L-H% boundary tone. One important alternative to consider is the possibility that the CT operator is in fact silent, and that the L-H% boundary instead originates with the CT phrase. To make this picture compatible with the topic abstraction account, we would then need to explain why a CT phrase—which is locally just an F-marked constituent—would be realized any differently than any other F-marked phrase. Since the binding CT operator is what defines a focused constituent as a CT, such an account would have to treat the L-H% tone as the reflex of an agreement relation between the CT operator and its associated F-marked phrase(s). I will refer to this alternative account as the AGREEMENT ALTERNATIVE.

In this section, we'll compare the agreement alternative to the SPC-driven account presented above. My goal is not to decide definitively between the two approaches (which make largely overlapping predictions), but rather to point out the crucial

places where the two accounts differ, and to point toward the kinds of evidence that would argue for one over the other.

Before we look at the differences, it is important to recognize a commonality across the two accounts. On the SPC account, to explain the fact that the L-H% morpheme isn't always pronounced directly at the left-peripheral CT operator position, we analyzed the morpheme as an intonational phrase clitic, drawn to the first IntP edge to its right. At first, it might seem that the agreement alternative would be able to do without this stipulation. Would it be enough to just say that L-H% is spelled out directly on the CT phrase itself? This approach would essentially make the agreement alternative just another version of a CT-marking account like Büring's (2003), and would thus make it vulnerable to the same criticisms. Examples like (68) and others from section §5.1 showed that the CT boundary tone can appear at a distance from the CT phrase.

(68) (Did Fred and Mary eat the beans?)

[FRED]_{CT} ate the beans...
 L+H* L-H%

Consequently, we can assume that the agreement alternative will still have to treat the CT morpheme as an intonational phrase clitic. Even if the CT phrase is the *origin* of the rising L-H% tone, it appears that the tone's surface position is sensitive to prosodic structure.

The major difference between the two accounts is in how they go about ensuring that the L-H% boundary surfaces in the same intonational phrase as the CT phrase. On the agreement-based account, this is guaranteed trivially: if the L-H% clitic originates with the CT phrase and is spelled out at the nearest IntP break, the two elements will necessarily surface in the same intonational phrase. On the SPC account, however, this basic fact was more difficult to capture. We posited the scope-prosody correspondence constraint and ranked it as undominated precisely to

enforce this generalization. Furthermore, to handle the finality of L-H% in Exh+CT examples (which is trivially captured on the agreement account), it was critical that we understood these sentences as having a different prosodic structure than CT+Exh examples. In particular, we assumed throughout that CT+Exh sentences are made up of two IntPs, while Exh+CT sentences consist of only one.

From one perspective, the agreement alternative seems preferable, since it erases the need for the SPC, and isn't forced to assume a phrasing asymmetry between CT+Exh and Exh+CT just to be able to position the L-H% boundary. On the other hand, if there actually *is* a phrasing asymmetry, then the SPC account has an advantage, since it both gives us a way to understand that asymmetry (which would otherwise be mysterious) and captures the positioning of L-H%, in one fell swoop. Thus, assessing whether the CT+Exh vs. Exh+CT phrasing asymmetry really exists is a crucial first step in deciding between these two approaches. At present, there has been very little experimental work in this domain, and so we have no solid basis on which to take this first step. In a moment, we'll look at some of the ways one could approach this empirical question.

Putting aside for now the question of the phrasing asymmetry, how else might we decide between the SPC account and the agreement alternative? Taking the simpler agreement alternative as the null hypothesis, let's look at a few of the challenges it would face.

5.8.1 Questions for Agreement

One general question facing the agreement alternative is whether there is any precedent for agreement between a focus operator and the F-marked phrase(s) it associates with. In English at least, I know of no other case where an F-marked phrase exhibits any segmental or prosodic reflex of the choice of the particular operator binding it

(e.g. *even, only*, etc.). Finding such a precedent, in English or another language would certainly lend plausibility to the agreement alternative.

Another high-level consideration is the “pressure to raise” discussed in §5.7. Our particular implementation of the SPC account allowed a tentative explanation of why CT+Exh order is preferred over Exh+CT order. If we move to the agreement alternative, this particular explanation is lost, so it would be worth exploring whether this preference could be grounded in some other way.

Turning to more tangible issues, let’s look in a bit more detail at what the agreement alternative predicts for the positioning of the L-H% boundary. For the most part, the agreement account makes the same predictions as the SPC account. Following the discussion in section §5.3, we’ll take prosodic structure to be derived through a combination of (i) syntax-phonology “match” constraints, (ii) prosodic markedness constraints, and (iii) the English-specific FOCUS-PROMINENCE constraint. Given these basic assumptions (and if FOCUS-PROMINENCE is relatively high-ranked, as before), then CT+Exh and Exh+CT will be phrased symmetrically as two international phrases, and the L-H% agreement originating with the CT phrase will be spelled out at the edge of whichever IntP contains that phrase. This is illustrated in the following pair, where the dash symbol ‘—’ marks a full falling intonational break sentence-medially.

- (69) a. I gave [FRED]_{CT} ... [the BEANS]_{Exh}.
 L+H* L-H% H* L-L%
- b. I gave [FRED]_{Exh} — [the BEANS]_{CT} ...
 H* L-L% L+H* L-H%

In the absence of other factors inducing IntP breaks, lone CT examples will work as before, with the CT agreement (L-H%) being drawn to the sentence-final position regardless of the position of the CT phrase, as follows:

(70) [FRED]_{CT} ate the beans...
 L+H* L-H%

Similarly in nested CT examples (containing multiple CT operators), each operator agrees with one CT phrase and we predict a separate IntP with final L-H% for each:

(71) (What about Fred and Sue? What did they give everyone?)

[FRED]_{CT} ... gave [MARY]_{CT} ... [a UKELELE]_{Exh}.
 L+H* L-H% L+H* L-H% H* L-L%

(And he gave Bill a kite. Sue ... gave John a tie and Ann a hat.)

Complex CT, on the other hand, is a potential problem. Recall that on the SPC account, when a single CT operator associates with multiple phrases, we predict only one realization of L-H%, and the SPC guarantees that the CT phrases will be integrated into a single IntP. This description fits the facts from section §5.6:

(72) (What did Fred and Mary give each other?)

[FRED]_{CT} gave [MARY]_{CT} ... [a UKELELE]_{Exh}.
 L+H* L- L+H* L-H% H* L-L%

(Mary gave Fred ... a tie.)

On the agreement alternative, by contrast, we seem to predict a reflex of agreement on each associated CT phrase. Here, we can draw an analogy to agreement in English coordinate structures, where typically agreement is realized in each conjunct, as in (73). Assuming agreement in complex CT structures works the same way, we would expect each agreeing CT phrase to host a L-H% morpheme of its own.

- (73) a. He peels and slices the carrots.
 b. ??He peel and slices the carrots.

If we had an independent reason to think that the two CT phrases in (72) would be phrased in a single IntP, we might avoid the problem by saying that two instances of L-H% *are* spelled out but gravitate to the same position, so we only hear one. However, on the agreement alternative, it isn't clear why two CTs bound by the same operator would be phrased in one IntP in the first place. Unlike the SPC account, there is no force to counteract the pressure from FOCUS-PROMINENCE to place the CT phrases in separate IntP domains. (Crucially, we would need this counteracting force to be active only in complex CT, not nested CT structures.) All in all, it appears that something additional would need to be said to derive complex CT prosody under the agreement alternative.

5.8.2 Evidence of Phrasing Asymmetry

Arguably the most important difference between the SPC account and the agreement alternative is that one requires a phrasing asymmetry between CT+Exh and Exh+CT, while the other treats these cases as symmetrical. The difference lies in the phrasing of Exh+CT, with the predictions of each account as follows:

- (74) a. I gave [FRED]_{Exh} [the BEANS]_{CT} ... (SPC Phrasing)
 H* L- L+H* L-H%
- b. I gave [FRED]_{Exh} — [the BEANS]_{CT} ... (Agreement Phrasing)
 H* L-L% L+H* L-H%

Deciding which of these is the right phonological representation of Exh+CT is a difficult task. The difference is in the prosodic break after *Fred*. In the SPC phrasing this is a phonological phrase (PhonP) break, while in the agreement phrasing we have a longer intonational phrase (IntP) break. Since the break consists entirely of low tones in either case, the two pitch contours have the same basic shape in terms of

peaks and troughs. The contrast, then, is just a matter of the size of the prosodic break, which is notoriously hard to quantify. In their guidelines for ToBI labeling, Beckman and Elam (1997) describe this challenge as follows:

When an intonation phrase is not the last one in an uninterrupted stretch of speech and it ends with a L% boundary tone, it is difficult to distinguish from [a phonological phrase] ending with the corresponding phrase accent just by examining the f0 contour. That is, the pitch differences between L-L% sequence and a mere L-, or between a H-L% sequence and a mere H-, are very subtle at best. Here the transcriber must rely on the subjective sense of degree of disjuncture, which is probably cued by such other things as the amount of preboundary lengthening or the degree of final lowering in the case of L-L% versus L-. (Beckman and Elam 1997: §2.3)

How might we go about building an argument for one or the other of these prosodic analyses? Let's consider a few approaches.

The most direct approach, and the one grounding most of the transcriptions in the literature, is to follow Beckman and Elam's (1997) advice to "rely on the subjective sense of degree of disjuncture". To determine how the medial break in an Exh+CT sentence compares to the medial break in CT+Exh order, we simply make a judgment as to how long each break feels. The results from this approach are inconclusive, but nevertheless suggestive. Many prosody researchers, including Pierrehumbert and Hirschberg (1990: ex. 33) and Steedman (2000: ex. 4, 2008: ex. 34b) transcribe Exh+CT examples with only a PhonP break medially, making the sentence a single IntP.³⁴ By contrast, as far as I am aware, all transcriptions of CT+Exh examples in the ToBI literature posit a medial IntP break. This points in the direction of the Exh+CT break being categorically shorter than CT+Exh.

It may be possible to elicit similar judgments of boundary length in an experimental setting. In a pilot experiment, I asked ten English speakers to judge how

³⁴Of the semantic work on CT prosody that provides ToBI annotations, most treats Exh+CT examples as containing two IntPs. I suspect that this reflects an adherence to Jackendoff's (1972: §6.7) view of "A accents" and "B accents" as rigid prosodic units, rather than any introspective judgment about the relative length of the break.

natural it would be to pause at particular positions in 44 different sentences. An initial prompt asked the subject to imagine pronouncing the target sentence, as in (75). The placement of stress was indicated orthographically with a combination of italics, bold and underline.

(75) First, imagine yourself saying this sentence:

“*Somebody* got *all* the answers right!”

After a four-second delay, a second prompt appeared, asking the subject to rate how natural it would be to pause at a particular position within the sentence, as follows:³⁵

(76) How natural would it be to pause at the position indicated?

“*Somebody* ... got *all* the answers right!”

Each item had a twin (presented as a later item) that differed in a crucial way semantically, while holding the low-level prosodic structure as close to constant as possible. For instance, the item paired with the above example was:

(77) First, imagine yourself saying this sentence:

“*Nobody* got *all* the answers right!”

(78) How natural would it be to pause at the position indicated?

“*Nobody* ... got *all* the answers right!”

Each minimal pair was designed so that one item, like (75), would force a CT+Exh reading, while the other, like (77), would force an Exh+CT reading. In the above case, this was achieved by exploiting the fact that *all* resists being a CT except in downward-entailing contexts, like under the scope of *nobody* (cf. section §2.4). Two

³⁵This was a forced multiple choice, between the options (i) extremely natural, (ii) very natural, (iii) somewhat natural, (iv) somewhat unnatural, (v) very unnatural, and (vi) extremely unnatural.

similar pairs are given below, with the target information structure roles now marked explicitly, and ‘...’ indicating the position of the prosodic break to be judged:

- (79) a. A [FEW]_{CT} of them ... [WANTED]_{Exh} to be arrested!
b. [NEITHER]_{Exh} of them ... [WANTED]_{CT} to be chosen!
- (80) a. I rated the [SECOND]_{CT} movie ... as [AWFUL]_{Exh}.
b. I didn’t rate [ANY]_{Exh} movie ... as [AWFUL]_{CT}.

The results of this pilot showed initial support for the idea that it is more natural to pause medially in CT+Exh order than in Exh+CT order. For instance, on a scale ranging from 1 (extremely unnatural) to 6 (extremely natural), the three CT+Exh examples above got average naturalness-of-pause scores in the 3–4 range, while their Exh+CT counterparts got average scores in the 2–3 range.³⁶ Across all 22 pairs, a linear mixed effects model with subject and pair as random effects found a significant effect of CT+Exh vs. Exh+CT order on the naturalness-of-pause rating ($p < 0.001$), with an estimated increase of 0.37 rating points for being CT+Exh, as compared to the Exh+CT baseline.

While these results are suggestive of an asymmetry, they are still a few steps removed from the specific claim that CT+Exh has a medial IntP break while Exh+CT is a mere PhonP break. To test this particular claim, we would eventually hope to appeal to independent diagnostics of English IntP and PhonP status. One might, for instance, attempt to quantify a particular threshold of duration or pre-boundary lengthening that robustly cues an IntP-level break in the prosody. Alternatively, one might look for segmental phonological processes that are sensitive to a given prosodic domain. For example, a lenition process like “flapping” (the pronunciation of the /t/ phoneme as a flapped allophone in certain intervocalic contexts) might

³⁶Specifically, the three CT+Exh examples above got average scores of 3.5, 3.1 and 3.7, while the corresponding Exh+CT examples got average scores of 2.8, 2.4 and 2.4.

turn out to apply across a PhonP break, but be blocked or restricted across IntPs. Pierrehumbert and Talkin (1992) discuss two additional cases of lenition that may be analyzable in these terms. Conversely, we might find strengthening processes that apply IntP-initially, but not more generally PhonP-initially. These possibilities will require careful empirical work to sort out.

One final source of evidence comes from declination and pitch reset phenomena. Declination refers to the tendency for fundamental frequency (F_0) to decline gradually over the course of an utterance (Ladd 1984). In a canonical case, declination results in the lowering of successive pitch targets, as illustrated schematically in Figure 5.1.

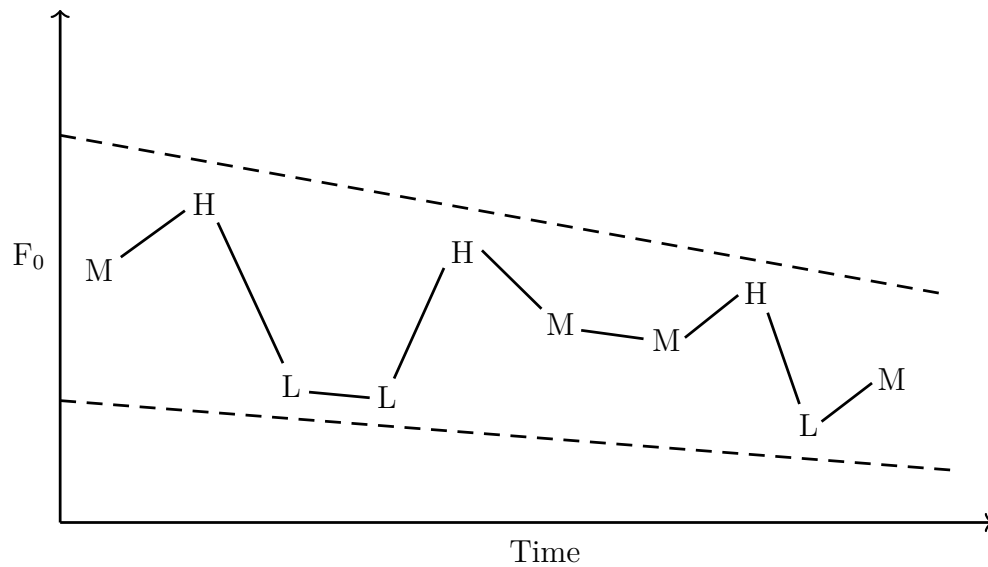

Figure 5.1: Declination, adapted from Ladd (1984)

Under certain circumstances, this overall downtrend can be interrupted mid-utterance, resulting in a full or partial “pitch reset”. According to the findings of Ladd (1988), pitch reset occurs at large boundaries—for instance, between conjoined clauses—and interestingly, the degree of reset (i.e. the pitch height returned to) correlates with the size of the boundary in question. This generalization is summarized by Ladd as follows:

[The results] show that the sentence's hierarchical structure [...] has an effect on the *amount* of reset: Clause-initial accent peaks are higher following a stronger boundary. (Ladd 1988: 541)

This general principle immediately predicts that an IntP boundary will induce a greater degree of pitch reset than a PhonP boundary. In CT+Exh examples, which are uncontroversially taken to involve two IntPs, we should then expect a large reset after the first IntP, so that the Exh accent is articulated in roughly the same pitch range as the earlier CT accent. What about Exh+CT examples? Crucially, if an Exh+CT structure consists of two IntPs, then it should exhibit the same degree of sentence-medial pitch reset that we see in CT+Exh examples, resulting in little or no declination between Exh and CT. On the other hand if Exh+CT only consists of a single IntP, as assumed by the SPC account, then we expect a smaller pitch reset at the medially boundary. In this case, declination should be more apparent, with the final CT accent realized in a narrower pitch range than the initial Exh accent.

In this domain, the work of Liberman and Pierrehumbert (1984) provides solid experimental findings to draw on. Across the productions of four speakers who recorded over 100 productions each, the authors found a remarkably stable asymmetry between CT+Exh and Exh+CT pitch contours. They observe that in the CT+Exh condition, the two pitch peaks have roughly the same height, while in Exh+CT productions, there is a surface downtrend through the two peaks. This contrast is clearly visible in Figures 5.2 and 5.3 from Liberman and Pierrehumbert, as well as in the original exemplifying pitch tracks of CT+Exh and Exh+CT from chapter §2 (cf. Figures 2.1 and 2.2).³⁷

The relative visibility of declination (or equivalently, the relative lack of pitch reset) in Exh+CT examples, as compared to CT+Exh examples, is automatically

³⁷Liberman and Pierrehumbert adopt Jackendoff's broad descriptions of the contours, referring to the Exh and CT contours as "A accents" and "B accents" respectively.

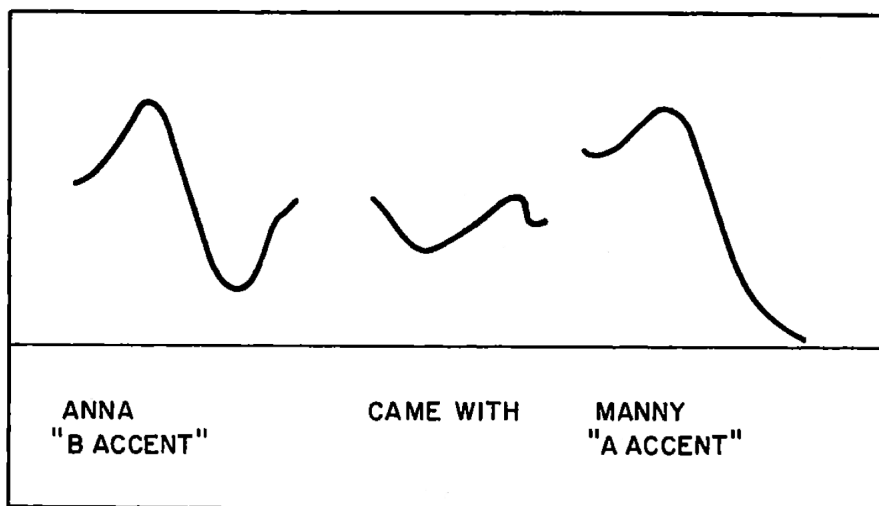

Figure 5.2: CT+Exh contour, from Liberman and Pierrehumbert (1984)

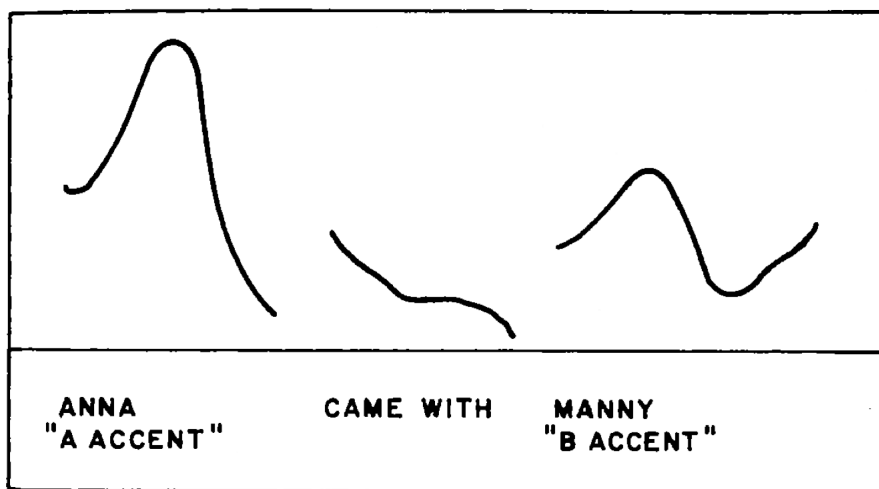

Figure 5.3: Exh+CT contour, from Liberman and Pierrehumbert (1984)

captured by the combination of (i) the claim that Exh+CT is one IntP, and (ii) Ladd's generalization that pitch reset is stronger at stronger boundaries. Thus these findings could be held up as support for a phrasing asymmetry of the kind assumed by the SPC account.

While this is one plausible interpretation of the surface facts, other explanations are possible as well. Liberman and Pierrehumbert (1984) take the observed surface asymmetry as evidence that, regardless of their order, the Exh accent is more prominent than the CT accent. On this view, the reason that CT and Exh reach roughly equal pitch peaks in CT+Exh order is that declination has lowered the more prominent Exh to the same height as CT. In Exh+CT order, by contrast, the effect of declination would be to lower the already less-prominent CT, thereby accentuating the existing contrast in prominence between the two phrases.

As long as this alternative explanation is a contender, the declination facts can't be construed as evidence that CT+Exh and Exh+CT are prosodically asymmetric.³⁸ However one puzzle for Liberman and Pierrehumbert's (1984) view is the question of why an Exh phrase would have to be more prominent than a CT in the first place. Especially on a configurational account where both CT and Exh are locally just F-marked, it's hard to imagine what would call for one to bear more prominence than the other.³⁹ It remains to be seen whether this picture could be squared with a general model predicting the relative prominence level of different types of focus (cf. Katz and Selkirk 2011). Overall, to see which explanation of the declination asymmetry is correct, we need an independent corroboration of the prosodic phrasing in these examples—evidence of the kind discussed earlier in this section.

³⁸Indeed Liberman and Pierrehumbert (1984: 169) assume that both orders are phrased as two intonational phrases.

³⁹Additionally, the assumption that Exh is inherently more prominent than CT makes what seems to be a spurious prediction about lone Exh vs. lone CT examples—namely that a lone Exh sentence should have a higher level of nuclear stress than a lone CT sentence.

In summary, while we have clear evidence that CT+Exh and Exh+CT differ in the relative height of their peaks, this is not yet a knock-down argument for adopting the phrasing asymmetry assumed by the SPC account. Thus, to date, we have no definitive answer as to the what the right prosodic representation for Exh+CT is. With luck, the development of additional diagnostics for distinguishing IntP vs. PhonP level breaks will allow us to resolve the question of phrasing experimentally. If we find no phrasing asymmetry, the SPC account will have to be abandoned in favor of something like the agreement alternative. On the other hand, if Exh+CT can be shown to have a categorically more integrated phrasing than CT+Exh, as I've suggested throughout, then this is strong evidence for something like the SPC.

Moving on, I'll continue to assume the phrasings that motivated the SPC account. The following sections discuss remaining issues that arise irrespective of our analysis of the phrasing facts, and irrespective of our choice of SPC vs. agreement.

5.9 Predicting Accent Shape

One issue that I've avoided throughout is the role of pitch accent shape in distinguishing CT from Exh phrases. The account I've presented simply requires the presence of prominence on F-marked elements, which translates into the need for a pitch accent, but no direct predictions about what type of pitch accent we will find.

It is not uncommon to find the view that CT phrases uniformly contain rising pitch accents (typically L+H*, or for some authors L*+H as well), while Exh phrases have falling accents (H*). For example, this view is promoted by Steedman (1991, 2000, 2008) and Vallduví and Engdahl (1996). My transcriptions throughout also conform to this view, although this should not be taken as an endorsement of the claim that the contrast is robust. In fact, there is a significant body of evidence suggesting that the facts are not so clean-cut. For example, Hedberg and Sosa (2008) provide evidence from corpora of spontaneous speech that the H* vs. L+H* contrast

doesn't reliably map onto focus vs. topic meanings (or any sub-type thereof), and Katz and Selkirk (2011: 788) review various findings that H^* vs. $L+H^*$ are not reliably distinguished in perception or production.

There have also been various claims that the rising accents themselves differ in meaning based on their alignment with the stressed syllable. For instance, an early-aligned rise $L+H^*$ and a late-aligned rise L^*+H are distinguished by Ward and Hirschberg (1985), Hirschberg and Ward (1992), Pierrehumbert and Steele (1989), Pierrehumbert and Hirschberg (1990) and Steedman (2000, 2008), although these authors are far from agreeing what the difference in meaning is. In some cases, a specific meaning contrast has been hypothesized between a "rise-fall-rise" contour L^*+H $L-H\%$ and a "contrastive topic" contour $L+H^*$ $L-H\%$ (Ward and Hirschberg 1985, Constant 2012a).

I will not rule out here the possibility that these contrasts in accent shape and alignment are meaningful at some level. They may be categorical contrasts, as assumed in the ToBI tradition, or gradient distinctions, as Ladd (1980, 1983) and Gussenhoven (1984) maintain in the case of accent alignment. But in any case, the point that I would like to make is just that if such meaning differences exist, they are orthogonal to the contribution of CT. Specifically, I claim that at their core, the three contours (i) H^* $L-H\%$, (ii) $L+H^*$ $L-H\%$ and (iii) L^*+H $L-H\%$ all convey CT meaning. Thus, I predict that (modulo some exceptions to be discussed in section §5.10) any attested use of these contours should occur in a context supporting a construal of the accented phrase as CT. Furthermore, where CT is illicit (e.g. on maximal quantifiers), all three variations should be unacceptable. If one of the three variants is (dis-)preferred in a particular CT context, I leave open the possibility that this is due to either (i) extra semantic licensing conditions imposed by the choice of accent, or (ii) phonological conditions affecting the viability of the individual accent shapes in a given phonological and prosodic context (cf. Steele 1986, Silverman

and Pierrehumbert 1990, Rietveld and Gussenhoven 1995, Prieto et al. 1995, Ladd et al. 2000, Ladd et al. 2009).

To my knowledge, these assumptions fit with nearly all uses of these three contours discussed in the literature, including those described as “rise-fall-rise” and transcribed as $L^*+H L-H\%$. If a clear example can be found where any of these contours is licensed but does *not* convey CT meaning, this would be a challenge to the account given so far. In the following section, we’ll explore some exceptions of this kind. However I’ll argue that these cases can be accounted for by the assumption that $L-H\%$ is inserted by default in certain prosodic contexts. Crucially, though, these exceptions don’t provide any evidence that the choice of pitch accent contributes to the availability of CT meaning. A true counter-example to the view that CT is “blind to accent choice” would be a context where more than one of the three contours is possible, but only a subset of these available contours support a CT interpretation. I know of no examples of this kind, and so am led to conclude that CT meaning resides exclusively in the $L-H\%$ boundary tone.

5.10 Over- and Under-Extension of CT Prosody

If English were designed with ease of analysis in mind, the contour $L+H^* L-H\%$ would convey a single meaning, and would never fail to appear when this meaning is present. But in fact, neither direction of this correspondence holds. In this section, we investigate both cases of “over-extension”, where the CT contour fails to convey CT meaning, and cases of “under-extension”, where CT meaning fails to exhibit CT prosody.

5.10.1 Over-Extension: Complex Focus and Initial Adjuncts

In the following examples, a pair of focused phrases provides the exhaustive answer to the question under discussion. These sentences are sometimes called “single-pair”

there is no such contrasting question; a single answer closes all the relevant issues. How then should we understand the use of the CT contour in these sentences?

One interpretation of the prosodic facts, following Wagner (2012), would be to say that *Cheney* and *Persephone* are in fact contrastive topics. This would demand weakening our semantics for CT to allow the possibility of CT-marked utterances that thoroughly resolve the question under discussion. However the cross-linguistic evidence points in a different direction. Across many languages with robust CT-marking mechanisms, complex focus constructions strongly resist CT-marking. For example, the Mandarin complex focus sentences in (83) and (84) fail to license the CT particle *-ne*, which is discussed in detail in chapters §6 and §7.

(83) (I heard someone hit someone, but I don't who hit who.)

Zhāngsān (#ne) dǎ-le Lǐsì.

Zhāngsān CT hit-PFV Lǐsì

'Zhāngsān hit Lǐsì.'

(elicited)

(84) (I heard that Lǐsì hit Zhāngsān.)

Bù bù bù, Zhāngsān (#ne) dǎ-le Lǐsì.

no no no Zhāngsān CT hit-PFV Lǐsì

'No, Zhāngsān hit Lǐsì!'

(elicited)

Similarly, Japanese CT *-wa* is illicit in complex focus contexts:⁴²

⁴²As discussed in section §2.5, some cases of *-wa* mark contrastive topics, while others mark aboutness topics. The two uses can be distinguished by prosody. However in (85) and (86) it isn't necessary to control for this, since neither use of *-wa* is acceptable.

(85) (I heard that someone hit someone, but I don't know who hit who.)
 Mary { **-ga** | **#-wa** } John-o tata-ita nda yo.
 Mary NOM TOP John-ACC hit-PAST EMPH PRT
 'Mary hit John.' (elicited)

(86) (I heard that John hit Mary.)
 Chigauyo, Mary { **-ga** | **#-wa** } John-o tata-ita nda yo!
 different Mary NOM TOP John-ACC hit-PAST EMPH PRT
 'No, Mary hit John!' (elicited)

And similarly again, as Sauerland (2005) observes, Hungarian single-pair answers can't be realized with the SOV order and "rising" intonation that mark Hungarian CT sentences (cf. Gyuris 2002). That is, the distinctive CT word order and prosody of a pair-list answer like (87) are inappropriate to a single-pair answer like (88):

(87) A: Mely fiú mely lány-t látta ?
 which boy which girl-ACC saw
 'Which boy saw which girl?' (pair-list question)
 B: János Mari-t látta, Gyuri Beá-t látta.
 János Mari-ACC saw Gyuri Bea-ACC saw
 'János saw Mari, and Gyuri saw Bea.' (Sauerland 2005)

(88) A: Mely fiú látta mely lány-t?
 which boy saw which girl-ACC
 'Which boy saw which girl?' (single-pair question)
 B: #János Mari-t látta.
 János Mari-ACC saw
 'János saw Mari.' (Sauerland 2005)

Taken together, these facts strongly suggest that single-pair answers are incompatible with CT meaning. If this is so, then we have to conclude that the English "CT contour" is over-extended. That is, not every occurrence of L+H* L-H% marks CT.

- (93) a. Xìngkuāi **ne**, cānyìyuán dōu dǐdá-le huìyìshì.
 Fortunately CT senator DISTR arrive-PFV meeting.room
 ‘Fortunately, the senators all arrived at the meeting.’
- b. Lùlùxùxù (??**ne**), cānyìyuán dōu dǐdá-le huìyìshì.
 one.after.another CT senator DISTR arrive-PFV meeting.room
 ‘One after another, the senators all arrived at the meeting.’ (elicited)
- (94) Wǒmen běnlái yǐwéi tā gòu zīgé, kěshì ...
 we originally think.wrongly he enough qualified but
 ‘We had originally assumed he was qualified, but ...’
- a. ... yàoshi tā shíjìshang bù hégé **ne**, wǒmen bù-néng gù tā.
 if he actually not qualified CT we not-can hire him
 ‘... if he actually isn’t qualified, we can’t hire him.’
- b. ... yīnwèi tā shíjìshang bù hégé (??**ne**), wǒmen bù-néng gù tā.
 since he actually not qualified CT we not-can hire him
 ‘... since he actually isn’t qualified, we can’t hire him.’ (elicited)

The observed split across adjuncts isn’t arbitrary. We’ve already seen that some phrases are pragmatically better suited to be CTs than others. Section §4.3 showed that quantifiers like *few* typically fail as CTs, and explained this failure in terms of the impracticality of breaking an issue into sub-issues along the lines of different proportions (e.g. “And what about *few* students? Where do *few* students live?”). Similarly, to interpret *quickly* as CT in (89b) would require an unusual context that addressed a set of parallel questions about contrasting manners, as in: {What did she do *quickly*? What did she do *slowly*? ...}.⁴⁵ Crucially, (89b) is acceptable even

⁴⁵As (i) shows, it is easier for *quickly* to receive a CT interpretation in lone CT sentences. In this regard, manner adverbs pattern with (non-existence-entailing) quantificational elements like *few*, *unlikely* and *seldom*, as discussed in section §4.4. See chapter §4 footnote 14 for some initial speculation as to what differentiates CT+Exh from lone CT discourse strategies at the conceptual level.

in the absence of such a context, so its “CT prosody” can’t be diagnostic of a CT reading.

Unlike manner adverbs, *fortunately* has a meaning that makes it a natural CT. More work needs to be done to flesh out the licensing conditions and compositional semantics of this and similarly-behaving adverbs, including *actually*. But to a first approximation, it seems plausible that these adverbs have a sense of contrast “built in” to them, automatically setting up discourses where they would be licensed as CT. For instance, both *fortunately* in (89a) and *xìngkuāi* ‘fortunately’ in (93a) demand that the utterance be a continuation, drawing a contrast between (i) how things might have turned out, according to some established prior fear or expectation, and (ii) how things actually turned out. It may be precisely because they invoke multi-part discourse structures of this kind (e.g. “We feared X, but fortunately Y”) that these adverbs can generally be CT-marked.

Along similar lines, it should be possible to trace the differing ability of *if*- and *because*- clauses to serve as CT back to the semantics/pragmatics of these adjuncts and the conceptual plausibility of the complex questions that their being CT-marked would presuppose. Section §6.3.6 provides a preliminary discussion of how to account for the *if* vs. *because* asymmetry, although a formal implementation is left as a problem for future research.

Putting aside the details of *why* some adjuncts make good CTs and others don’t, the surface facts of English (sentence-finally) and Mandarin make it clear enough that manner adverbials and *because*-clauses are in fact bad CTs. Thus, when these adjuncts bear the L+H* L-H% contour initially, we need to locate the source of the contour somewhere besides the CT operator.

(i) (Is it true that she solved the problem instantly?)

She solved it QUICKLY... (but not *instantly*...)
L+H* L-H%

Perhaps the simplest analysis of initial adjuncts is to treat them as displaying a rising prosodic contour only as a matter of phonological default. This view is compatible with the general proposal outlined above for the case of complex focus sentences. The only additional assumption needed is that initial adjuncts can be phrased separately from the rest of the clause (in a separate IntP) via the default syntax-phonology mapping. In other words, unlike subjects, isolating these initial adjuncts prosodically doesn't entail any non-canonical topic or focus structure. Once we explain the possibility of an IntP break, the choice of L-H% specifically can be handled just as in complex focus cases—as a default for non-final boundaries.

5.10.2 Under-Extension: CT Questions

Non-CT uses of the “CT contour” like those discussed in the previous section don't pose a direct challenge to our claim that the CT operator is lexicalized as L-H%. We can understand these “over-extensions” on a par with any lexical ambiguity in language. In fact, given that every IntP break hosts tonal material, and given the limited inventory of tonal movements we have to choose from (cf. Pierrehumbert 1980), it should be unsurprising to find a one-to-many correspondence between tonal shapes and functions (some of which may be semantically vacuous).

Under-extension of the CT contour poses a deeper problem. If the CT operator sounds like L-H%, we don't expect to find contexts that support CT meaning yet resist CT prosody. One such puzzling case is the lack of CT intonation in English questions. We saw in chapter §3 that CT questions are well attested cross-linguistically. Specifically, many languages extend the same CT-marking devices they use in declaratives to questions (§3.1.3), and the licensing conditions on these questions can be derived using the same CT operator semantics we posited for declaratives (§3.3). From this

could maintain that English CT operator is semantically licensed in questions, but when present it is phonologically unrealizable.

While it is hard to adduce definitive arguments for one or the other of these views, the second approach seems preferable for a few reasons. First, it is consistent with the null hypothesis that the meaning contribution of CT is stable cross-linguistically. Second, looking a little further, we find a plausible explanation for why CT might be unrealizable in English questions, and find a remarkably similar surface restriction on the Mandarin CT morpheme.

The basic explanation I have in mind is that English questions already have an interpreted tonal morpheme in sentence-final position, and that there “isn’t room” to realize two tonal clitics at this single boundary position. While the details of the compositional analysis of question intonation are a matter of debate (cf. Bartels 1997 for one refined analysis and a general overview), it is widely assumed that the final rise (H-H%) typical of English polar questions has some role to play in the construction of a polar question meaning. When we consider that most languages have overt segmental yes-no question markers (Dryer 2013)—many of them sentence-final—a natural interpretation of the English facts is to view H-H% as a question particle, along the lines of the Mandarin yes-no question particle *-ma*.

In this case, an English polar CT question phrased as one IntP simply has no way of giving realization to the two IntP clitics present in its logical form. Since the CT morpheme (L-H%) and the yes-no question morpheme (H-H%) are each unavoidably drawn to an IntP boundary, and since the intonational phonology of English only permits a single phrase-and-boundary tone combination at this position, one of the two morphemes is destined to go unheard. Based on the prosody of CT questions like (95), we can conclude that in such a battle for realization, the yes-no question morpheme wins.

In chapter §6, we'll see that the distribution of the Mandarin CT particle *-ne* in questions presents a remarkably similar pattern. While CT *-ne* is licensed sentence-finally in a wide range of questions—including wh- questions, alternative questions, and importantly, polar questions formed with A-not-A morphology—the CT morpheme is ruled out in polar questions questions formed by means of the sentence-final yes-no question particle *-ma*. In section §6.6.2, I argue that, as suggested for English above, there is no semantic incompatibility between CT *-ne* and yes-no *-ma*; rather a haplology constraint (cf. Stemberger 1981 and others) rules out the possibility of the two particles surfacing together.

Returning to English, this understanding of the absence of the CT contour in yes-no questions leads to an interesting hypothesis about the logical forms of English declaratives and wh- questions. While both declaratives and wh- questions are typically falling (L-L%), the CT morpheme is visible in declaratives, but invisible in wh- questions. Thus, we are led to hypothesize that in wh- questions, the L-L% fall encodes an interpreted wh- question morpheme, while in declaratives the fall is only there by default.⁴⁸ Whether there is independent evidence for this perhaps surprising view is a question for future research.

One final piece of evidence comes from questions that involve multiple intonational phrases. On the approach we've been considering, the only real incompatibility between CT prosody and questions stems from the fact that two separate tonal clitics are fighting for realization at a single prosodic boundary that can only host one of them. This type of explanation is compatible with the possibility that a question phrased as two intonational phrases will find a way to realize both of the morphemes overtly. The following example may be such a case:

⁴⁸Another possibility would be to say that all three clause types contain overt typing morphemes, but that the CT morpheme “wins” over declarative L-L% while “losing” to wh- question L-L%.

(97) (I know why *Antonio* went to *France*...)

But why did PERSEPHONE ... go to SPAIN?
L+H* L-H% H* L-L%

Here, the question contains two focused phrases separated by an intonational phrase break. If *Persephone* can be shown to be a CT (i.e. the F-marked associate of a CT operator), then we can view the medial L-H% as the realization of the CT operator, which, as always, is attracted to the IntP break closest to its left-peripheral position. However, given our findings in the previous section, there is also the possibility that the medial L-H% rise here is uninterpreted, as in “over-extended” complex focus examples. Demonstrating that this sentence contains a CT operator at all is an important prerequisite to using it to argue for how such an operator can or can’t be pronounced.

In summary, in both English and Mandarin, it appears that the CT marker is silent in sentences that contain a distinct morpheme realized in the position where we would expect the CT marker to surface. Attempting to describe these CT-neutralizing contexts in semantic terms may be possible for a single language, but leads to no real insights as to why the CT marker is missing. On the other hand, there is a promising explanation for these facts as a purely surface-oriented phenomenon. In Mandarin in particular, we will see that the silencing of CT in yes-no particle questions falls in with a more general pattern whereby homophonous and near-homophonous particles blend or delete rather than surface adjacent to each other.

CHAPTER 6

MANDARIN -NE AS CT

This chapter looks at the Mandarin discourse particle *-ne*, and argues that it can convey contrastive topic meaning (although we'll see that it has at least one other use as well). This is an important task because, if the arguments are convincing, they provide the first in-depth discussion of a CT marker that regularly occurs at a distance from the CT phrase.¹ The existence of such a morpheme can be taken as support for a theory of contrastive topic that sees CT phrases as the associates of a non-local and potentially overt CT operator.

The arguments supporting the claim that Mandarin *-ne* is a CT marker don't depend on any particular syntactic or semantic implementation of contrastive topic. Rather, the main evidence is that *-ne* shows behaviors that can be explained in terms of a basic notion of CT as signaling the presence of a set of multiple questions aimed at resolving a larger discourse issue. More specifically, we'll see evidence of two kinds. First, Mandarin *-ne* exhibits characteristic distributional properties of CT that are familiar from CT markers in other languages (e.g. resisting maximal elements). Second, additional properties of Mandarin *-ne* that are not immediately familiar from other languages (e.g. marking *if*-clauses but resisting *because*-clauses) can nevertheless be derived from the core conception of CT.

The subsequent chapter §7 provides a specific analysis of Mandarin *-ne* within the topic abstraction framework from chapter §3—as the lexicalization of the CT

¹See Constant (2011) and Tonhauser (2012) for preliminary evidence of the same kind.

operator. However the success or failure of that particular implementation should not reflect on the broader claim made in this chapter: that *-ne* marks CT meaning.

We will see that *-ne* surfaces in two positions: (i) after the topic in topic-comment structures, and (ii) sentence-finally in statements and questions. The core claims defended in this chapter with respect to Mandarin *-ne* are:

- (1) a. Topic-marking *-ne* in topic-comment structures marks the topic as CT.
- b. Sentence-final *-ne* in questions and statements either signals the presence of a CT, or marks durative aspect.

Beyond the claim that topic-marking *-ne* marks the topic phrase as CT, this chapter does not presuppose or argue for any specific analysis of the syntax, focus structure, or prosodic structure of individual sentences with *-ne*. As such, the arguments supporting the view of *-ne* as CT—and particularly those concerning sentence-final *-ne*—focus on the relation between whole sentences and their surrounding discourse contexts. The goal is just to demonstrate that sentences with *-ne* appear in precisely the kinds of discourses where we expect to find CT markers. However it should be kept in mind that there are important questions about the structure and formal analysis of individual sentences with *-ne* that need to be addressed before we can make fully robust predictions about the particle's distribution. Given the diversity of environments that *-ne* occurs in, this is a formidable task. We will address a small subset of cases in more rigorous detail in chapter §7, but the overall project of applying a formal analysis across a larger range of examples remains an area for future research.

There are a wide range of previous analyses of *-ne* in the literature, and these analyses make important contributions to understanding the particle's meaning and distribution. However since they do not, for the most part, shed light on the viability of the claim that *-ne* is a CT marker, I will not address them in any detail here. For detailed literature review, I refer the reader to Wu (2005) and Chu (2006). That

said, a few statements about *-ne* in the previous literature stand out as especially suggestive of CT meaning. I repeat these here, just to set the mood:

[Declarative-final] *-ne* is possible every time the discussion remains open. It is the case when one admits a mistake [...], an ignorance [...], when a hypothesis is brought forward [...], and also when one underlines the limits or the additive nature of the statement expressed [...].
(Alleton 1981: 108)

In declaratives, if a cognition verb is used, the speaker suggests [with *-ne*] that the problem being discussed is not solved—at the limit, it could be said that *-ne* takes the place of, or announces a subsequent question [...]. The statement about the present situation is never disconnected from the previous discourse and from that following.
(Alleton 1981: 111)

[W]hen *-ne* is used, what has been guessed, claimed, expected or believed to be a certain way is pointed out to be another way. In other words, two or more objects, concepts, or situations are put into *contrast*.
(Lin 1984: 237)

[Expressions corresponding to *-ne*] entail a necessity to look back at what has been going on, said or unsaid, in the current discourse. [...] At the same time, they also demand a continuation of the current discourse.
(Chu 2006: 12)

In the literature, comparatively little attention has been paid to topic-marking *-ne*, which is often regarded as a distinct morpheme from the sentence-final particle (Li 2006, Wu 2006). However in the existing work on topic-marking *-ne*, the connections to contrastive topic are even clearer. For instance, Lee-Wong (2001: 139) states that topic-marking *-ne* “signals topic shift and focuses on new, contrastive information”. Lee (2003: 357) is the first to my knowledge to connect (topic-marking) *-ne* to the class of CT markers cross-linguistically, and claims that topic-marking *-ne* “shows an explicitly expressed or listed contrast between two elements of the same type”.

The Mandarin data in this chapter come from three sources: (i) previous literature, (ii) naturally occurring examples (from novels, corpora, TV shows, or the web), and (iii) my own consultations with native speakers. Since Mandarin is spoken and written by a wide range of speakers with different linguistic backgrounds, there is an important

issue as to the extent of variation in how *-ne* is used across different dialects and social groups. The previous literature on *-ne* has tended to abstract away from any such variation. While I won't be able to offer any characterization of the nature of variation here, it seems almost certain that some variation does exist. In some cases, when I elicited judgments about a particular use of *-ne*, speakers would resist accepting a sentence, but at the same time would offer that it sounded like something others might say—for instance “someone from the countryside” or “someone being overly effeminate”. I have not attempted to reproduce or categorize these intuitions here.

To the degree possible I have tried to minimize variation by focusing on a specific dialect: the Mandarin spoken in Beijing and the surrounding Hebei province. My primary consultants were two female speakers in their twenties from Baoding, Hebei. Additional consultants were all from northern mainland China, primarily Beijing and Hebei. I am extremely grateful to everyone who has contributed judgments, intuitions, examples and discussion. In particular, I would like to thank Bitian Zhang, Xiaoxia Ma, Rui Guo, Ming Shao, Chloe Chenjie Gu, Li Julie Jiang and Haixia Man.

The naturally occurring written examples used in this chapter, to the degree possible, were selected from sources that could be placed to a particular time and location. Two sources I relied on heavily are Lǎo Shě's (老舍) 1936 novel *Rickshaw Boy* (骆驼祥子) and transcripts of the 1993 sitcom *I Love My Family* (我爱我家), both of which are written in colloquial Beijing dialect. Examples from other sources were checked against native speakers from Beijing or Hebei for naturalness.

Regardless of the source, the translations and glosses are my own. With glosses, this is in order to maintain consistency, and to clarify which uses of *-ne* are to be treated as CT. In a number of cases, I have modified translations given in the literature in order to (i) make the English more colloquial, (ii) conform to the intuitions reported by consultants, or (iii) highlight the relation of the sentence to the surrounding discourse. Neither the translations nor the glosses should be taken as data

in their own right, or as evidence in support of any analysis. Finally, I have provided native orthography for all Chinese examples, as a convenience for those who will prefer reading them in this format.

6.1 Background on Mandarin Particles

Mandarin *-ne* is one of as many as 28 discourse particles in the language (Chao 1968: §8.5.5). The Mandarin particles are bound morphemes enclitic to preceding material, and are always unstressed and occur in neutral tone (Chao 1968: 795, Li and Thompson 1981: 238).² In addition to *-ne*, the set of Mandarin particles includes most prominently *-ma* (for yes/no questions), *-ba* (for suggestions and suppositions), *-le* (for new situations, among other uses) and *-(y)a* (for vocatives, commands, and exclamations, among other uses). The particles typically occur sentence finally, and regularly co-occur. When more than one particle is present, they stack up in predictable orders, and may fuse in pronunciation (e.g. *le + (y)a* → [la]). See Li (2006) for a thorough treatment of the ordering facts.

As for the meaning of the various particles, Wu (2005: 48) identifies two camps of research: the “meaning maximalists” and “meaning minimalists”. The maximalists, beginning with Chao (1968), attempt to enumerate all possible meanings of the particles in neutral descriptive terms, while the minimalists, starting with Li and Thompson (1981) attempt to unify seemingly disparate uses under a core meaning, often framed in abstract terms. Thus, for example, the seven distinct uses of *-ne* identified by Chao are reduced by Li and Thompson to a core meaning of “response to expectation”.

With certain particles, even the hardcore minimalists have to admit to formally distinct meanings that just happen to be homophonous. One such clear case is with

²As Chao (1968: 795) points out, these properties distinguish particles from INTERJECTIONS, which can occur in isolation, and receive stress.

the particle *-le*. Li and Thompson (1981: §6.1, §7.1) argue that when *-le* cliticizes to a verb, it marks perfective aspect, whereas the sentence-final use—often called INCHOATIVE *-le*, following Chao (1968: 782)—marks a “currently relevant state”. This analysis has been widely adopted, and in fact, given the differences in both the syntax and semantics of these uses, a truly minimalist analysis of *-le* would be difficult to maintain.³ Surprisingly though, when a verb is sentence final and both the perfective and the inchoative meanings are licensed, only one occurrence of *-le* is ever pronounced (Li and Thompson 1981: 296–300). Rather than indicating that the two types of *-le* are the same on some level, this fact is widely, and I believe correctly, understood as a surface phenomenon, reflecting a morpho-phonological haplology constraint against adjacent realization of the two distinct and interpretable morphemes *-le* (Chan 1980). In section §6.8.6, I argue that a similar constraint rules out the possibility of more than one instance of *-ne* surfacing. This constraint has obscured the line between two separate uses of *-ne*, with the result that minimalist theorists have largely attempted to collapse them.⁴

In addition to sentence-final uses, a subset of the Mandarin discourse particles (specifically, *-(y)a*, *-ne*, *-me* and *-ba*) may also occur immediately following a sentence-initial topic phrase (Chao 1968: 81; Chu 2003, 2006).⁵ I will refer to these uses as TOPIC-MARKING.⁶

³For a few radical approaches in this vein, and the challenges they face, see Chan (1980: 44–61).

⁴Accounts that avoid distinguishing aspectual *-ne* include Li and Thompson 1981, Lin 1984, Wu 2005, Chu 1998, 2006, and Li 2006, among others.

⁵While I follow Chu and others in writing the topic-marking particle as *-me*, rather than *-ma*, it is not clear to me whether this orthographic convention reflects any difference in pronunciation. The vowel seems to be a schwa in either case.

⁶To my knowledge, there has been next to no discussion of the potential differences between these four topic-marking particles in the literature. Chu (2003: 277) suggests that *-ne*, *-me* and *-ba* all mark a topic as contrastive. However in later work, Chu (2006: 21) argues that only *-ne* demands contrast. For my part, I have focused on *-ne* and leave the comparison with other topic markers as a problem for future research.

6.2 Surface Distribution of *-ne*

6.2.1 Positions *-ne* Occurs

We can begin by identifying four places where *-ne* appears. These are (i) marking a sentence-initial topic, (ii) in “fragment questions”, (iii) finally in declaratives, and (iv) finally in questions. The following examples from Chu (2006) illustrate these four basic uses:

(2) Topic-Marking *-ne*

(Every day mom doesn't come home until late.)

爸爸 呢, 干脆 就 不 回来。

Bàba **ne**, gāncuì jiù bù huí-lái.

dad CT simply just not return-come

‘(And) dad NE, doesn't even come back at all.’ (Shao 1989: 174)

(3) Fragment Question *-ne*

(Zhāngsān is going to Japan, Lǐsì is going to Korea...)

你 呢?

Nǐ **ne**?

you CT

‘(How about) you NE? (Where are you going?)’ (Tsao 2000: 16)

(4) Question-Final *-ne*

A: “Old K”? How come I didn't know that people call him “Old K”?

B: 你 认识 他 有 多 久 了 呢?

Nǐ rènshi tā yǒu duō jiǔ le **ne**?

you know he have how long ASP CT

‘(Well) how long have you known him NE?’ (Shie 1991: 149–153)

(5) **Declarative-Final -ne**

A: His family is poor, so you'd do better not to interact with him.

B: 他 家 有 三 头 牛 呢。

Tā jiā yǒu sān tóu niú **ne**.

his family have three CL cow CT

'His family has three cows NE... (!)'

(Isn't that proof that they're not poor?)

(Tsao 2000: 16)

The remainder of this chapter focuses on treating each of these four categories in turn. To preview the upcoming analysis, I argue following Lee (2003) that topic-marking *-ne* always marks contrastive topic. Similarly, I claim that in fragment questions, *-ne* always conveys CT. With sentence-final *-ne*, the situation is more complicated. We will see that some uses, as the ones above, mark contrastive topic, while other uses mark durative aspect. However, before we turn to these specific categories, we can make a few generalizations that hold across all four uses.

6.2.2 Colloquial, Frequent, Optional

Irrespective of where *-ne* occurs and what meaning(s) it conveys, we can characterize the particle as restricted to a relatively informal register. Furthermore, even in colloquial contexts where the use of *-ne* is frequent, its appearance in a particular sentence (if possible) is nearly always optional.

Li and Thompson (1981: 238) indicate that Mandarin discourse particles are all essentially colloquial, occurring typically in spontaneous conversation, or writings that reflect conversations. This is especially true of *-ne*, which they claim (p. 305) is not found in scientific reports or in expository writings. Corpus work on the particle, including the work of Lin (1984), Wu (2005) and Li (2006), has drawn on examples from novels that contain natural dialogue or are written in a colloquial style.

Searching a corpus for *-ne* is relatively easy due to a near one-to-one correspondence between the Chinese character 呢 and the particle.^{7,8} When we compare the frequency of the particle across corpora of different styles, we find clear evidence of a bias for *-ne* to appear in informal, colloquial settings—particularly in the speech of Beijing. As Figure 6.1 shows, *-ne* occurs regularly in sitcoms and novels (especially those employing a colloquial Beijing dialect), less frequently in online product reviews, and extremely rarely in newspaper articles. At one extreme, in the sitcom *I Love My Family*, the particle is uttered on average once every 270 characters (syllables)—or around twelve times per episode. By contrast, in journalistic style of the national Xinhua press agency *-ne* only occurs once every 90,000 characters, and these rare uses tend to be direct quotations of colloquial speech. Descriptions of the six corpora represented in Figure 6.1 are given in (6).

⁷In the few interfering non-particle uses, the character occurs within larger expressions and is pronounced *ní*. An exhaustive list of such expressions in the ABC dictionary (DeFrancis 2003) consists of the rare botanical term 棕黑粗呢 ‘burnet’, the word 呢喃 ‘twittering’ and related expressions (耳语呢喃, 梦中呢喃, 睡中呢喃, 燕语呢喃), and a set of words related to wool: 薄呢, 粗花呢, 大衣呢, 格呢, 格子花呢, 格子呢, 格字呢, 海军呢, 黑呢, 黑呢帽, 黑呢子, 华达呢, 花呢, 灰呢, 灰呢子, 坚固呢, 将校呢, 镜面呢, 军服呢, 礼服呢, 马海呢, 马裤呢, 毛呢, 棉华达呢, 呢料, 呢料子, 呢帽, 呢帽毡, 呢绒, 呢子, 青呢, 青呢子, 人字呢, 台球呢, 烫呢机, 线呢, 毡呢, 制服呢, 直贡呢, 绉呢, 煮呢. Within each of six corpora represented in Figure 6.1, these uses account for only between 0–1% of the occurrences of the character 呢.

⁸There are also several orthographic representations of the particle *-ne* beyond the standard 呢. For instance Chao (1968: 801) uses the character 呐 as the default for all meanings of *-ne*. Based on its relative infrequency in the corpora I studied, it appears that this usage is fading. Chao (1968: 797) also notes that when *-ne* occurs before the particle *-(y)a*, the two merge in pronunciation to [na]. In modern usage, this combination is typically written with one of the characters 呐 or 哪. However since these characters have other, more frequent meanings, I have ignored them in my corpus work reported below.

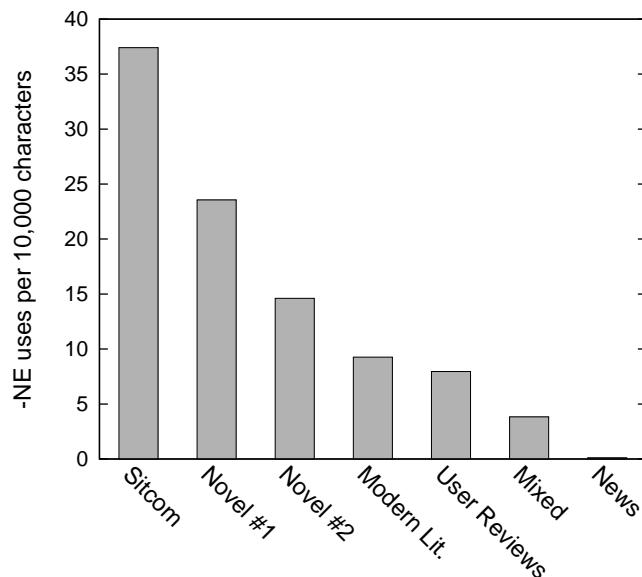

Figure 6.1: Frequency of *-ne* in different corpora

- (6) a. **Sitcom**: Transcripts of a 1993 sitcom set in Beijing.⁹
 b. **Novel #1**: A 1936 novel employing colloquial Beijing dialect.¹⁰
 c. **Novel #2**: A 1987 novel employing colloquial Beijing dialect.¹¹
 d. **Modern Lit.**: A collection of modern novels, essays, poems, etc.¹²
 e. **User Reviews**: A collection of product reviews entered by users online.¹³
 f. **Mixed**: A mix of written genres, including news, periodicals and literature.¹⁴
 g. **News**: Newspaper articles from the Xinhua press agency.¹⁵

⁹Full transcripts of all 120 episodes of the 1993–1994 sitcom *I Love My Family* (我爱我家).

¹⁰Lǎo Shě's (老舍) *Rickshaw Boy* (骆驼祥子).

¹¹Wáng Shuò's (王朔) *The Operators* (顽主).

¹²The “mainland novels” (大陆小说) subset of the CCRL corpus (Chinese Corpus Retriever for Language Teaching and Research), created by Beijing Language and Culture University (北京语言大学). The materials appear to all have been published in the P.R.C. (1949–present). I thank professor Rou Song (宋柔) for making this corpus available to me.

¹³The Chinese portion of the UMass Amherst Linguistics Sentiment Corpora (Constant et al. 2009), containing over 500,000 online product reviews from Amazon.cn.

¹⁴The modern subset of Peking University's Center for Chinese Linguistics (CCL) corpus, containing over 700 million characters of text from a wide range of written genres, published in post-imperial China (1911–present). Available at http://ccl.pku.edu.cn:8080/ccl_corpus/

¹⁵The Xinhua subset of the Penn Chinese Treebank 6.0 (Xue et al. 2005), containing over 300,000 characters of news text from mainland China's official press agency, published 1994–1998.

Even in the colloquial style best suited to *-ne*, its use in individual sentences appears to be largely optional. According to Lin (1984: 220), *-ne* can be omitted in all cases except fragment questions like (3) above, where removing the particle is impossible:¹⁶

(7) (Zhāngsān is going to Japan, Lǐsì is going to Korea...)

你 #呢?

Nǐ #**(ne)**?

you CT

‘(How about) you NE? (Where are you going?)’ (Chu 2006: 27)

The only other case I know of where (what looks like) *-ne* is obligatory is when it occurs in conjunction with the particle *-zhe* following an adjective, as follows:

(8) 那 个 房间 黑 着*(呢)。

Nèi gè fángjiān hēi **zhe-*(ne)**.

that CL room black PRT-PRT

‘That room is pretty dark NE.’ (cf. Li and Thompson 1981: 222)

According to Chao (1968: 248, 797), this use is better understood as a single compound particle *-zhene* expressing intensity. Li and Thompson (1981: 222) also treat this combination as an intensifier, remarking that the usual aspectual meaning of *-zhe* is lost, and that this usage is restricted to northern dialects.¹⁷ Thus, I will treat these examples as not involving *-ne*, and ignore them from here on.

¹⁶To be precise, Lin’s (1984) claim is that the only places *-ne* is obligatory are in fragment questions *and* in conditionals used as questions, as in (i). In section §6.4 we will see that these cases can be analyzed as fragment questions as well, so there is no need to state them separately.

(i) 要是 他 长得 不好看 呢?
Yàoshi tā zhǎngde bù-hǎokàn **ne**?
if he look not-good-looking CT

‘And if he’s not good-looking NE?’ (Lin 1984: 234)

¹⁷By contrast, when *-zhe* and *-ne* appear together marking a *verb*, the durative meaning of *-zhe* is maintained, and *-ne* can be dropped:

With *-zhene* out of the way, the generalization that emerges is that *-ne* is quite widely optional, with fragment questions being the only exception. Perhaps related to this general optionality is the fact that *-ne* tends to be perceived as not being part of what was literally said. In this regard, the contribution of *-ne* is comparable to that of English intonation. As one illustration of the particle’s “invisibility”, we can note that *-ne* may be added by a narrator reading from a script that lacks the particle. For instance, in Dǒng Hángjì’s (董行佶) reading of the 1936 novel *Rickshaw Boy* (骆驼祥子) for a book on tape, *-ne* is added in several cases where it was absent in the original text, including the following example:

- (9) 祥子 呢, 是 乡下人。
 Xiángzi **ne**, shì xiāngxià-rén.
 Xiángzi CT be rural-person
 ‘Xiángzi NE was a villager.’

While *-ne* resembles CT morphemes of other languages in not contributing any literal meaning, its colloquial status and overwhelming optionality are not familiar features of CT. By comparison, in English examples like (10), CT intonation is claimed to be mandatory (Büiring 2003: 526):

-
- (i) 他 还 活着 (呢)。
 Tā hái huó-zhe (**ne**).
 he still live-DUR DUR
 ‘He’s still living.’

(elicited)

(10) A: What did the pop stars wear?

B: The [FEMALE]_{CT} pop stars ... wore [CAFTANS]_{Exh.} (Büring 2003: 526)
L+H* L-H% H* L-L%

This specific claim about English may be slightly too strong. In particular, an alternative to CT intonation would be to use listing intonation:

(11) The FEMALE pop stars wore CAFTANS, and the MALES wore DASHIKIS.
L* H- L* H-H% L* H- H* L-L%

Nevertheless, the basic insight is correct. While speakers of the above examples can choose between CT intonation and the (relatively unusual) listing intonation, there is no option to just leave the word *female* unaccented, and so a choice of pitch accent is unavoidable.

By contrast, the Mandarin particle *-ne* is strictly extra. A speaker is never forced to choose only between *-ne* and another meaningful overt form. Given the general optionality of *-ne*, any analysis of its meaning will need to be grounded in contrasts between contexts where the particle is *allowed* (but not necessary) and contexts where it is *disallowed*.

6.3 Topic-Marking *-ne*

Early mentions of topic-marking *-ne* simply characterize the particle as used to make a deliberate pause (Chao 1968: 802). However more recent work claims that topic-marking *-ne* always signals a contrast between the marked topic and another topic (Lin 1984: 232–233, Lee-Wong 2001, Lee 2003: 357, and Chu 2006: 13–14).¹⁸

¹⁸Both Lee-Wong (2001) and Chu (2006) say the contrast has to be *backwards-looking*, implying that a contrasting topic appeared earlier in the discourse. While this does seem to be the general tendency, attested examples like (15) below indicate that at least some uses of *-ne* are forward-looking. In light of such counterexamples, I'll avoid stipulating any directionality requirement on *-ne*. However for researchers testing the felicity of *-ne* in constructed examples, respecting the directionality bias may still an important prerequisite to naturalness.

In this section, I'll defend the claim that *-ne*-marked topics are contrastive topics. Rather than relying on intuitive notions of “contrast” and “topic”, I fall back on the core notion of CT as marking that only one part of a larger issue is being addressed, and that other sub-issues involve alternatives to the CT phrase. We'll also see that topic-marking *-ne* exhibits behavior familiar from CT morphemes cross-linguistically, as in (12a–c), as well as less familiar behavior that can still be traced back to the meaning of CT, as in (12d):

(12) **CT-like Behavior of Topic-Marking *-ne***

- a. resists exhaustive foci
- b. resists non-contrasting topics
- c. resists maximal elements
- d. marks *if*-clauses, but resists *because*-clauses

6.3.1 Mandarin Topic Position

Of the four positions *-ne* shows up, topic-marking *-ne* is the only one where the particle is sentence-medial. Thus, we can easily delimit “topic-marking” uses without appealing to any particular notion of what it means to be a topic. Nevertheless, there is good reason to think that the phrases that sentence-medial *-ne* follows are indeed topics, in both a syntactic and a semantic sense. In this section, I review at an informal level the syntactic and semantic properties of Mandarin topics.

Mandarin TOPIC POSITION refers to a left-peripheral position hosting phrases that, roughly speaking, establish what the following sentence is adding new information about (cf. Shi 2000).¹⁹ For example, in (13), the object *Zhāngsān* appears leftward

¹⁹Shi (2000: 386) refers to topic position as preceding a clause, which seems to imply being clause-initial. However, I assume that a sentence can have more than one topic, in which case the second topic is no longer clause-initial. At the same time, “left-peripheral” is not a specific enough notion, since non-topic material may also occur in the Mandarin left periphery. See e.g. Constant and Gu 2010 for discussion of movement of the focus of ‘even’ to a left-peripheral focus position.

of the subject, and establishes what the sentence is adding information about. I will refer to a phrase in topic position as a SYNTACTIC TOPIC.²⁰

(13) 张三, 我 已经 见过 了。

Zhāngsān, wǒ yǐjīng jiàn-guo le.

Zhāngsān I already see-EXP ASP

‘(As for) Zhāngsān, I’ve already seen (him).’ (Li and Thompson 1981: 15)

Phrases that do not meet the semantic criteria for topic-hood (which I will not define precisely) cannot appear in topic position. Thus, for example, (13) would be inappropriate as a complete response to a question about who I’ve already seen. In this case, *Zhāngsān* would be interpreted an exhaustive focus, providing the information that the person I’ve already seen was *Zhāngsān*, rather than anyone else.

While clause-initial subjects are often syntactic topics, this is not always the case.²¹ For example, the subject in (14) is an exhaustive focus, providing the new information that resolves the question of who will give the lecture. This subject is not a topic, and hence is not in topic position, by definition.

²⁰It is reasonable to assume that syntactic topics occupy a dedicated position (or one of several dedicated positions) in the left periphery (cf. Rizzi 1997 and much subsequent work in the cartographic tradition). On this view, a subject could occupy different syntactic positions, depending on whether it is a topic or not. However I will not present any specific evidence bearing on the question of whether this is the right analysis of Mandarin subject topics.

²¹This is contra Chao’s (1968: 69) claim that Mandarin subjects are always topics.

(14) A: Who will give the lecture?

B: 王老师 讲。

Wáng-lǎoshī jiǎng.

Wáng-teacher speak

‘Professor Wáng will do it.’

(elicited)

6.3.2 Kinds of Topics Marked by *-ne*

This section provides some initial “soft” evidence that topic-marking *-ne* conveys CT meaning, by looking at the kinds of topics that the particle attaches to in naturally attested examples. Specifically, we will make two informal observations about the distribution of topic-marking *-ne*. First, when we examine attested examples in context, we find contexts that support the construal of the *-ne*-marked phrases as CTs. Second, of the different kinds of topics marked, we find that the particle most frequently marks elements that fit naturally (one might say automatically) into CT discourses. These include *if*-clauses and adverbials meaning ‘furthermore’ and ‘actually’.

Topic-marking *-ne* appears on a wide range of phrasal categories, including DPs, PPs, adverbials, and clausal adjuncts.²² Typical examples of each type are given in (15–18), all from the novel *Rickshaw Boy*. In each case, the sentence with topic-marking *-ne* functions to answer a question about the *-ne*-marked topic, which contrasts with a salient question about a different topic in the context.²³

²²Topics corresponding to VPs are also possible, but it is not immediately clear whether these phrases have been nominalized. I will not explore this distinction here.

²³I have selected these sentences on the basis that they provide relatively clear examples of CT meaning. In many attested examples, the context does not make the contrast being drawn so explicit.

- (15) (Well in that case, there are only two roads to take.) **DP topic**

一 条 呢， 是 凑 钱 买 上 车，
Yī tiáo **ne**, shì còu qián mǎi-shàng chē,
one CL CT be gather money buy-RES cart,

一 条 呢， 是 暂 且 赁 车 拉 着。
yī tiáo **ne**, shì zànqiě lìn chē lā-zhe.
one CL CT, be for.now rent cart pull-DUR

‘One road NE, is to save up the money to buy a rickshaw.

The other road NE, is to rent a rickshaw to pull for the time being.’

- (16) (Pulling Mr. Cáo in the rickshaw was pleasant work.) **PP topic**

在 家 里 呢， 处 处 又 是 那 么 清 洁 ...
Zài jiā-li **ne**, chùchù yòu shì nàme qīngjié ...
at home-LOC CT everywhere also be that tidy

‘And as for life at home NE, everything was tidy and it was always peaceful.’

- (17) (In Xiángzi’s eyes, Mr. Cáo was like Confucius.) **Adverbial topic**

其 实 呢， 曹 先 生 并 不 怎 么 高 明。
Qíshí **ne**, Cáo-xiānsheng bìng bù zěnmē gāomíng.
actually CT Cáo-mister on.contrary not how wise

‘But in reality NE, Mr. Cáo wasn’t really so wise.’

- (18) (I don’t know if she can wash and do chores.) **Clausal topic**

假 若 她 能 作 些 事 呢， 就 让 她 帮 助 高 妈。
Jiǎruò tā néng zuò xiē shì **ne**, jiù ràng tā bāngzhù Gāo-mā.
if she can do bit work CT then have her help Gāo-maid

‘If she can do a little work NE, then we’ll have her help out Mrs. Gāo.’

In (15), two possible roads forward are being contrasted, and in describing what the roads consist of, the speaker marks each occurrence of the topic ‘one road’ with *-ne*. In (16), the *-ne*-marked topic ‘at home’ is contrasted with an earlier (unmarked) topic ‘at work’. In (17), the actual state of the world is contrasted with the world as

seen through Xiángzi’s eyes. And in (18), the possibility that Xiǎo Fúzi can do some chores is implicitly contrasted with the possibility that she can’t.

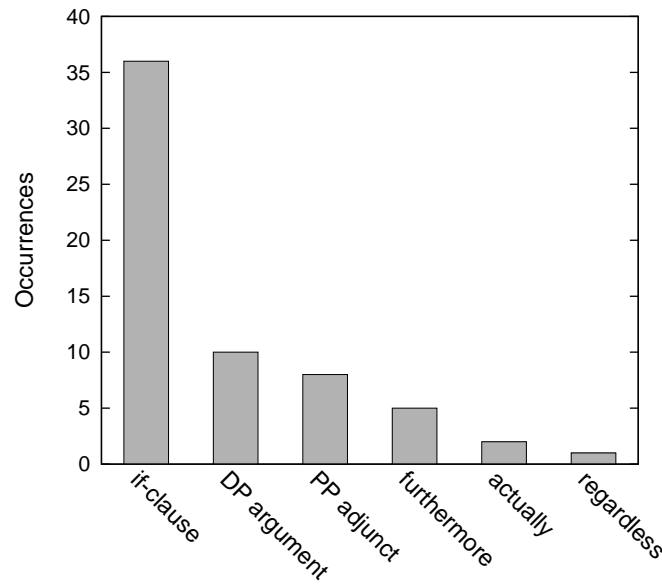

Figure 6.2: Topics marked by *-ne* in 1936 novel *Rickshaw Boy*

Beyond the evidence from specific examples, the frequency of *-ne* usage across different types of topic phrases lends plausibility to the claim that *-ne* marks CT. Figure 6.2 shows the distribution of topic-marking *-ne* in the novel *Rickshaw Boy*.²⁴ Remarkably, more than half of the 62 occurrences of topic-marking *-ne* in the text mark *if*-clauses. On the view that *-ne* marks CT, we can make sense of this distribution just in case *if*-clauses are especially well-suited to be contrastive topics. In fact, this is a reasonable premise, given how conditionals tend to be used in discourse. Conditional statements canonically present hypothetical possibilities, and typically when one possibility is being considered, a contrasting possibility is also relevant to the discussion.²⁵ Specifically, conditional discourses often proceed along the lines of the

²⁴This distribution excludes uses of *-ne* in fragment questions. Section §6.4 considers deriving fragment questions with *-ne* from topic-comment structures with topic-marking *-ne*, via ellipsis of the comment. However this is not the only analytical option.

²⁵For more detailed discussion of this point, and various exceptions, see section §6.3.6.

schematic in (19). Or in more general terms, conditionals often function to break up a larger issue into sub-issues that seek answers in different contingent scenarios. We will return to discuss the facts with conditionals in more detail in section §6.3.6.

- (19) If [possibility #1]_{CT}, then [result #1]_{Exh}.
 If [possibility #2]_{CT}, then [result #2]_{Exh}.

Also noteworthy is the frequency that adverbials meaning ‘furthermore’ (*hái-yǒu*, *zàishuō*) and ‘actually’ (*qíshí*) show up with topic-marking *-ne*. We saw an example with ‘actually’ already in (17). An example with ‘furthermore’ is the following:

- (20) (Rather than buying another rickshaw, she decided to put the money aside.
 She couldn’t be empty-handed in the event that her husband left her.)

再说 呢，刘老头子 这样 一 走， 使 她 感到
 Zàishuō **ne**, Liú-lǎotóuzi zhè-yang yī zǒu, shǐ tā gǎn-dào
 furthermore CT Liu-old.man this-way once leave cause her feel-RES

什么 也 不可靠。
 shénme yě bù-kěkào.
 what all not-reliable

‘And furthermore NE, after how her dad had left, she felt nothing was reliable.’
 (*Rickshaw Boy*)

Like *if*-clauses, these adverbials make natural contrastive topics. *Furthermore* is used in discourses where multiple pieces of evidence are used to support a common conclusion. If we understand *furthermore* as ‘another reason’, then a sentence with *furthermore* will always provide a partial answer to the question of whether the conclusion is warranted, and will fit into a discourse with the shape given in (21). We can paraphrase the discourse strategy here as a complex question “What are all the reasons for this conclusion?”.

- (21) [One]_{CT} reason for the conclusion is [reason #1]_{Exh}.
 [Another]_{CT} reason for the conclusion is [reason #2]_{Exh}.

Finally, the function of *actually* is to draw a contrast between an accurate view of the world and some salient but inaccurate view. If we understand *actually* as denoting the correct view of reality, then it generally fits into discourses of the following kind:

- (22) On [some incorrect view]_{CT}, [conclusion #1]_{Exh}.
 But on [the correct view]_{CT}, [conclusion #2]_{Exh}.

Overall, looking at the types of topics that *-ne* frequently marks provides suggestive preliminary evidence that these phrases could be interpreted as contrastive topics. In the following sections, we turn to “harder” evidence, where *-ne* is shown to display CT-like behavior across a range of positive and negative elicited data.

6.3.3 *-ne* Resists Exhaustive Foci

First, if it is correct that sentence-medial *-ne* only marks contrastive topics, it should be impossible to find *-ne* on a constituent that is an exhaustive focus—an element that provides a complete answer to the question under discussion. This expectation is borne out in examples like the following:

- (23) A: Who is the tallest?
 B: 李四 (#呢) 最 高。
 Lǐsì (#ne) zuì gāo.
 Lǐsì CT most tall
 ‘Lǐsì (#NE) is the tallest.’ (elicited)

(24) A: Hey, who spilled Coke on my book?

B: 李四 (#呢) 干 的。

Lǐsì (#ne) gàn de.

Lǐsì CT do DE

‘Lǐsì (#NE) did it.’

(elicited)

As a CT marker, *-ne* is predicted to be resist marking an exhaustive focus, capturing the impossibility of (23) and (24). But we can also look at this data from another angle. Topic-marking *-ne* can only mark syntactic topics, and as an exhaustive focus, the phrase *Lǐsì* in these examples is ineligible to appear in topic position. We see the problem more clearly in cases where the exhaustive focus isn’t sentence-initial. For example, in (25), the exhaustive focus *Lǐsì* can’t be topicalized, and hence isn’t in the right position to be marked by topic-marking *-ne*.

(25) A: Which candidate did Zhāngsān choose?

B: 他 选了 李四。

Tā xuǎn-le Lǐsì.

he choose-PFV Lǐsì

‘He chose Lǐsì.’

B’: #李四, 他 选了。

#Lǐsì, tā xuǎn-le.

Lǐsì he choose-PFV

Literally: ‘Lǐsì, he chose.’

(elicited)

In sum, the fact that topic-marking *-ne* can’t attach to an exhaustive focus is expected on the view that *-ne* marks CT, but can also be explained in simpler terms, since an exhaustive focus can’t be a topic. These facts would be compatible with the view that *-ne* is a generic topic marker. However, this view doesn’t hold up when we turn to non-contrasting topics.

6.3.4 *-ne* Resists Non-Contrasting Topics

It is often observed that Mandarin tends to organize sentences into topic-comment structures (see e.g. Li and Thompson 1976 and Shi 2000: 387). One way of understanding why Mandarin topic-comment structures are so prevalent is in terms of the relatively wide range of interpretations available to syntactic topics. In particular, Mandarin syntactic topics are not necessarily interpreted contrastively. Thus, the sentence in (26) is possible even in contexts where it would be hard to interpret the syntactic topic *rèlìxué* ‘thermodynamics’ as being contrasted with other topics. For instance, this could be the first sentence uttered by a professor at the first meeting of a thermodynamics class.

- (26) 热力学, 大部分 的 人 可能 都 没 听说过。
Rèlìxué, dàbùfen de rén kěnéng dōu méi tīng-shuō-guo.
thermodynamics most DE person possible even have.not hear-say-EXP
‘Most people have probably never even heard of thermodynamics.’
Literally: ‘Thermodynamics, most people...’ (elicited)

By contrast, English doesn’t allow the non-contrastive construal of syntactic topics.²⁶ Thus, (27b) is unnatural as the opening sentence of a thermodynamics class. However, the sentence is acceptable in a context supporting *thermodynamics* as a contrastive topic, as in (28).²⁷

²⁶This claim holds of topics that are associated with a gap in an argument position in the clause. With clause-initial scene-setting or clausal adjuncts, a contrastive interpretation is not necessarily required.

²⁷As Prince (1999: §3.1) observes, specific discourse conditions can also allow the construal of English fronted material as focus, as in her example “She was here two years. <checking transcript> FIVE semesters she was here.” Note however that the thermodynamics example (27b) does not support such a construal.

- (27) a. Most people have probably never even heard of thermodynamics.
 b. Thermodynamics, most people have probably never even heard of.
- (28) Some areas of physics, like relativity, are quite famous. But thermodynamics, most people have probably never even heard of.

We just saw that Mandarin syntactic topics are not always interpreted contrastively. However, when *-ne* appears following a topic, only a contrastive interpretation is available. Thus, (29) is possible in a contrastive context like (28), but impossible as the opening sentence of a thermodynamics class. In this respect, the sentence with *-ne* patterns with the English counterpart where the topic has been fronted.

- (29) 热力学 呢, 大部分 的 人 可能 都 没 听说过。
 Rèlìxué **ne**, dàbùfen de rén kěnéng dōu méi tīng-shuō-guō.
 thermodynamics CT most DE person possible even have.not hear-say-EXP
 ‘Thermodynamics NE, most people have probably never even heard of.’
 (elicited)

Similar facts have been observed by Chu (2006: 21). In (30a), topic-marking *-ne* is licensed on *bàba* ‘dad’, since this topic contrasts with the earlier topic *māma* ‘mom’. However in (30b), the use of *-ne* on the same sentence is impossible, since ‘dad’ and ‘school’ don’t contrast in the relevant way. (More on this below.)

- (30) a. 妈妈 每天 晚上 很 晚 才 回家。
 Māma měi-tiān wǎnshang hěn wǎn cái huí-jīā.
 mom every-day night very late only.then return-home
 爸爸 呢, 干脆 就 不 回来。
 Bàba **ne**, gāncuì jiù bù huí-lái.
 dad CT simply just not return-come
 ‘Every day mom doesn’t come home until late.
 Dad NE, doesn’t even come back at all.’ (Shao 1989: 174)

- b. 学校 五点 才 放学。
 Xuéxiào wǔ-diǎn cái fàng-xué.
 school five-o'clock only.then let.out-school
 爸爸 (#呢), 干脆 就 不 回家。
 Bàba (#ne), gāncuì jiù bù huí-jiā.
 dad CT simply just not return-home

‘School doesn’t let out until 5pm.

Dad (#NE), doesn’t even come home at all.’ (Chu 2006: 21)²⁸

More precisely, we can say that ‘dad’ in (a) is licensed as CT because the sentence answers a question about when dad gets home, which contrasts with the earlier question about when mom gets home, and these two questions address a common larger issue (When do mom and dad get home?). In (b) however, there is no way of understanding the two statements as addressing a unified issue (e.g. When do school and dad let out and come home?).

Overall, the data in (29) and (30) make it clear that *-ne* is more than just an optional topic marker. Mandarin topics have a wide range of interpretations, whereas *-ne*-marked topics must be interpreted as CT. In this sense, Mandarin *-ne* is unlike Japanese *-wa* and Korean *-(n)un*, which mark both contrastive and thematic (non-contrastive) topics.

6.3.5 *-ne* Resists Maximal Elements

Recall from section §2.4.2 that maximal elements like *all* typically resist being marked as contrastive topics. Specifically, we saw that *all* can only be a CT in downward-entailing contexts (e.g. under the scope of negation).

²⁸I’ve changed *huí-lái* ‘come back’ to *huí-jiā* ‘return home’, to make Chu’s example slightly more natural. However one speaker still reports difficulty imagining any context where the two sentences would be uttered in sequence.

Applying this diagnostic in Mandarin, the first thing to observe is that *-ne* will never mark the quantifier within a nominal directly. For instance, *-ne* is impossible in between the quantifier *dàbùfen* (*de*) ‘most (of)’ and the following noun:

- (31) 大部分 (*呢) 的 (*呢) 事情 都 很 难办。
 [Dàbùfen (*ne) de (*ne) shìqing]_{DP} dōu hěn nán-bàn.
 most CT DE CT matter DISTR very hard-manage
 ‘[Most (*NE) of these things]_{DP} are hard to deal with.’ (elicited)

Rather, as we’ve seen above, *-ne* marks phrasal expressions that can serve as syntactic topics. Thus, if *dàbùfen* ‘most’ is to stand as contrastive topic, *-ne* will occur at the end of the containing noun phrase, as in (32a). This frame lets us compare *dàbùfen* ‘most’ with *suǒyǒu* ‘all’. As predicted if *-ne* is a CT marker, the maximal quantifier *suǒyǒu* ‘all’ is incompatible with *-ne*-marking.

- (32) a. 大部分 的 事情 呢, 都 很 难办。
 DÀBÙFEN de shìqing ne, dōu hěn nán-bàn.
 most DE matter CT DISTR very hard-manage
 ‘Most of these things NE are hard to deal with.’
 b. 所有 的 事情 (*呢) 都 很 难办。
 SUǒYǒU de shìqing (*ne) dōu hěn nán-bàn.
 all DE matter CT DISTR very hard-manage
 ‘All of these things (*NE) are hard to deal with.’ (elicited)

Note that the positioning of stress is relevant in these examples. I’m assuming that stress on the quantifier indicates narrow focus on the quantifier, establishing the quantifier as the alternative-generating CT. If this were not the case, it would be difficult for any theory of CT to explain the infelicity of (32b). By comparison, if stress appears on the noun, we allow contrasts between different noun denotations, with the quantifier remaining fixed. In this case, *-ne* is possible even on nominals

containing *suǒyǒu* ‘all’, as in (33). This is expected on standard theories of CT as long as we identify the CT as the stressed noun.

- (33) 所有 的 女人 都 可能 有 类似 的 经历。
 Suǒyǒu de NŪRÉN dōu kěnéng yǒu lèisì de jīnglì.
 all DE woman DISTR maybe have similar DE experience
 所有 的 男人 呢, 可能 都 缺乏 这 方面 的 经验。
 Suǒyǒu de NÁNREN ne, kěnéng dōu quēfá zhè fāngmiàn de jīngyàn.
 all DE man CT maybe DISTR lack this respect DE experience
 ‘All *women* have probably experienced something similar.
 (But) all *men* NE, probably lack this type of experience.’ (elicited)

Finally, recall that English CT intonation is possible on maximal elements when appearing under the scope of negation. For example, the CT *all* in (34) scopes under negation, giving the meaning “Not all politicians are corrupt” (not > all).

- (34) [ALL]_{CT} politicians aren’t corrupt... (cf. Büring 1997a: 180)
 L+H* L-H%

However, as Mandarin is a SCOPE-RIGID language (see Huang 1982a: §3 and many following), we can’t find parallel examples to test with topic-marking *-ne*. Specifically, there are no examples where an element meaning ‘all’ occurs structurally higher than negation, but still takes narrow scope. To get the narrow scope meaning, ‘all’ needs to be below negation in the overt syntax, as in (35). However in this case, *-ne* is impossible since the CT phrase is not in topic position. Overall, the lack of scope inversion effects with *-ne* is derivable from independent factors, and doesn’t reflect on the claim that *-ne* is CT.

- (35) 不是 所有 的 人 (*呢) 都 反对 ...
 Bú-shì SUǒYǒU de rén (*ne) dōu fǎnduì ...
 not-be all DE person CT DISTR oppose
 ‘Not *everyone* (*NE) was opposed... (only some people were).’ (elicited)

6.3.6 *-ne* Marks *if*-clauses, Resists *because*-clauses

Mandarin sentence-initial clausal adjuncts are often followed by a spoken pause, and often written with comma. Based on informal descriptions of *-ne* as a “pause particle” (Chao 1968: 802), one might expect that any clausal adjunct could be followed by *-ne*. However this is not the case. There is a clear contrast between *if*-clauses, which can nearly always host *-ne* and *because*-clauses, which categorically resist *-ne*. The following elicited minimal pair illustrates:²⁹

- (36) 我们 本来 以为 他 够 资格, 可是 ...
 Wǒmen běnlái yǐwéi tā gòu zīgé, kěshì ...
 we originally think.wrongly he enough qualified but
 ‘We had originally assumed he was qualified, but ...’
- a. ... 要是 他 实际上 不 合格 呢, 我们 不能 雇 他。
 ... **yàoshi** tā shíjìshàng bù hégé **ne**, wǒmen bù-néng gù tā.
 if he actually not qualified CT we not-can hire him
 ‘... if he actually isn’t qualified NE, we can’t hire him.’
- b. ... 因为 他 实际上 不 合格 (#呢), 我们 不能 雇 他。
 ... **yīnwèi** tā shíjìshàng bù hégé (**#ne**), wǒmen bù-néng gù tā.
 since he actually not qualified CT we not-can hire him
 ‘... since he actually isn’t qualified (#NE), we can’t hire him.’

The generalization that *-ne* marks *if*- but not *because*- clauses holds up against corpus data as well. In *Rickshaw Boy*, there are 122 occurrences of *because*, but only one instance is marked with *-ne*, and this is a case of the aspectual morpheme *-ne* that

²⁹Many speakers prefer (36a) with the addition of the adverb *jiù* ‘then’ in the consequent clause, as in “[...] wǒmen jiù bù-néng gù tā.” I’ve left it out here so as to have a minimal pair with (b).

- (37) If [scenario #1]_{CT}, then [result #1]_{Exh}.
 If [scenario #2]_{CT}, then [result #2]_{Exh}.

Looking in a little more detail, it will help to distinguish several types of conditional, following Iatridou (1991: §2). The garden-variety conditional is a **HYPOTHETICAL** conditional, as in (38a), where the antecedent functions to describe a hypothetical set of circumstances under which the consequent would be true. By contrast, in **RELEVANCE** conditionals like (38b), the antecedent specifies the conditions under which the consequent is *relevant*. Finally, in **FACTUAL** conditionals like (38c), the antecedent is already accepted as true.³³

- (38) a. If you're hungry, you won't win the race. **Hypothetical**
 b. If you're hungry, there's biscuits in the fridge. **Relevance**
 c. A: I'm hungry.
 B: Oh. If you're hungry, we should get you some food. **Factual**

The antecedents of hypothetical conditionals make good contrastive topics, since considering one hypothetical possibility almost inevitably leads to questions about contrasting possibilities. In fact, one common function of hypothetical conditionals is to break up complex issues into more manageable sub-issues that seek answers in different contingent scenarios. For instance, I can take a seemingly straightforward question about what I'll do tomorrow and answer it piecemeal as "If it rains, I'll do some reading. If it's hot, I'll go swimming. If it's windy, I'll fly a kite."

Non-hypothetical conditionals, on the other hand, do not typically set up contrasts with different antecedents. For example, it is strange to respond to the relevance conditional (38b) with "And if I'm *not* hungry?". The speaker's intent was not to establish the contents of the fridge under each of several scenarios, but rather to

³³Relevance conditionals are also known as "biscuit" conditionals, and factual conditionals as "premise" conditionals.

qualify the conditions under which the biscuits in the fridge are relevant. Similarly, by the time the factual conditional (38c) is uttered, it is already established that speaker A is hungry, so there isn't any contrasting question needing to be addressed about what we should do if A isn't hungry. In this case, following up with "And if I'm *not* hungry?" is clearly infelicitous.

Since factual conditionals are incompatible with contrasting antecedents, we predict they should not support CT-marking. The strangeness of *-ne* in the following example confirms this prediction, on the view that *-ne* is a CT marker.³⁴

(39) A: 他说 今天 身体 不 太 舒服。

Tā shuō jīntiān shēntǐ bú tài shūfu.

he say today body not too well

'He says that he's not feeling well today.'

B: 他 要是 不 舒服 (#呢), 咱们 就 改 一 天 见面 吧。

Tā yàoshi bù shūfu (#ne), zánmen jiù gǎi yī tiān jiànmiàn ba.

he if not well CT we just change one day meet PRT

'If he's not feeling well (#NE), then let's meet on another day.' (elicited)

Furthermore, note that precisely the same sentence supports *-ne* when it is used as a hypothetical conditional rather than a factual conditional:

³⁴The sentence-initial pronoun *tā* 'he' has raised from its base position as the subject of the *if*-clause. It isn't immediately apparent whether this movement, presumably targeting aboutness topics, is to a matrix position or just to the edge of the adjunct clause.

(40) (Go and ask him how he's feeling today.)

他 要是 不 舒服 呢, 咱们 就 改 一 天 见面 吧。
Tā yàoshi bù shūfu **ne**, zánmen jiù gǎi yī tiān jiànmiàn ba.
he if not well CT we just change one day meet PRT

'If he's not feeling well NE, then we'll just meet on another day.' (elicited)

Since the content of factual conditional antecedents has already been established, these antecedents are in fact roughly equivalent to *because*- or *since*- clauses:

(41) A: I'm hungry.

B: Oh. If you're hungry, we should get you some food.

B': Oh. Since you're hungry, we should get you some food.

Why do *because*-clauses make bad CTs? Consider that in a hypothetical conditional, the possibility expressed by the antecedent clause can always be contrasted with the other possibilities, including the polar opposite possibility: "And if not?". Since *because*-clauses convey established rather than hypothetical content, there is no corresponding option of contrasting polar opposite *because*-clauses. For instance, if you tell me that we'll have to cancel the picnic because it's raining, there is no sense in my asking "And because not?".

But beyond the impossibility of contrasting directly opposing *because*-clauses, it is difficult in general to conceive of a coherent larger issue made up of sub-questions about contrasting *because*-clauses. Such a discourse would have the following shape:

- (42) A: What happened because of reasons #1 and #2?
 B: Because of [reason #1]_{CT}, [consequence #1]_{Exh}.
 Because of [reason #2]_{CT}, [consequence #2]_{Exh}.

There is nothing fundamentally inconceivable about a discourse like (42). The claim I would like to make is just that reasons are highly unnatural means of breaking up an issue into smaller pieces. Consider the ease with which the question “What will happen?” can be broken up according to hypothetical scenarios, as in (43a). By contrast, breaking up the same question according to reasons is confusing, as the strangeness of (43b) shows:

- (43) a. What will happen in these ten scenarios?
 b. ??What will happen for these ten reasons?

Perhaps the cognitive difficulty posed by (43b) derives from the difficulty of conceptualizing reasons in isolation of the consequences that follow from them. A reason isn’t a reason at all until we know what it’s a reason for. Thus, typically, we start with a consequence and ask for the reason behind it. Put differently, reasons make good answers, not good questions. We see this in the following contrast:³⁵

- (44) a. And if it rains? (What will happen then?)
 b. ??And because it will rain? (What will happen because of that?)

Returning to the Mandarin facts, we see that even discourses that overtly list a sequence of *because*-clauses do not easily license the use of *-ne* marking them as contrasting. At best, sentences using *-ne* to contrast *because*-clauses are marginally acceptable. In the following elicited example, there is a relatively cohesive issue that can be paraphrased as “What bad consequences are explained by the reasons that

³⁵The use of *and* rules out the possibility that these questions are interpreted as suggested answers. Otherwise, “Because it will rain?” could be put forward as a potential answer to the question of why the picnic was canceled.

(49) (Xiángzi has been injured in an accident. After he washes the blood off his face, the maid Mrs. Gāo is waiting with medicinal ointment.)

“胳膊 和 腿上 呢?” 高妈 给 他 脸上 涂抹了 一气。
“Gēbei hé tuǐ-shang **ne**?” Gāo-mā gěi tā liǎn-shang túmǒ-le yīqì.
arm and leg-LOC CT Gāo-maid give him face-LOC apply-PFV at.once
‘“(And what about) your arms and legs NE?” Mrs. Gāo asked, as she gave his face a good smear.’ (Do *they* need medicine?) (Rickshaw Boy)

I use the term FRAGMENT question to highlight the parallel between these and the more widely discussed fragment answers (see Merchant 2005, among many others). Within the Chinese literature, these questions are usually referred to as TRUNCATED questions following Li and Thompson (1981: 305).

Fragment questions with *-ne* have been called THEMATIC questions (Wu 2006), indicating the topic status (or theme status) of the fragment. Two points from the literature on thematic questions are worth highlighting here. First, there is a clear intuitive connection between the fragment question *-ne* and topic-marking *-ne*, as noted by Chao (1968: 81–82), Fang (1994), Zhang and Fang (1996), Tsao (2000), Chu (2006) and Wu (2006).³⁷ Li (2006: 20) summarizes Fang’s (1994) observation of this tight connection by saying that the only difference between the two uses is that in thematic questions, the speaker invites the hearer to provide the focus corresponding to the topic marked by *-ne*, whereas with topic-marking *-ne*, the speaker herself provides the focus in the subsequent clause. Since topic-marking *-ne* marks CT, if Fang’s intuition is valid then fragment question *-ne* does the same.

Beyond pointing out the similarities to topic-marking *-ne*, the literature on thematic questions also provides an informal characterization of their use conditions. The consensus is that fragment questions with *-ne* mark a transition to a new topic, and ask a particular question about that topic. According to Wu (2006), thematic

³⁷The references to Fang (1994) and Zhang and Fang (1996) come from Li (2006: 20). The reference to Tsao (2000) comes from Chu (2006: 21).

questions pose a new topic against an old topic from the context, and invite the hearer to provide an appropriate focus according to the preceding discourse or situation.³⁸ Similarly, Li (2001) observes that *-ne* can attach to a topic to form a question only when its corresponding focus is missing in comparison with a neighboring topic/focus pair in the discourse.³⁹ Overall, these descriptions suggest that the topic marked in a thematic question must contrast with another topic, and that each topic defines a (sub-)question that needs to be resolved. In other words, thematic questions are CT questions. This view is summed up in Chu's (2006: 21) statement: "[T]he [fragment] question is a contrastive topic [...] seeking for an appropriate comment."

The distribution of fragment question *-ne* provides further support for the claim that this use of *-ne* marks CT. As with topic-marking *-ne*, the majority (15/24) of fragment questions with *-ne* in *Rickshaw Boy* are *if*-antecedents. The following example shows a case where two *if*-antecedents are explicitly contrasted. The first is marked with topic-marking *-ne*, while the second uses fragment question *-ne*. The fact that a CT with topic-marking *-ne* can overtly contrast with the phrase in a fragment question with *-ne* fits with the view that both uses of *-ne* convey CT.

- (50) 假若 老头子 消了 气 呢, 她 只要 [...].
 Jiǎruò lǎotóuzi xiāo-le qì ne, tā zhǐyào [...].
 if old.man cool-PFV temper CT she so.long.as

假若 老头子 硬到底 呢?
 Jiǎruò lǎotóuzi yìng-dào-dǐ ne?
 if old.man firm-to-end CT

'If her dad's temper had cooled NE, she could send her husband back to work for him and eventually he could take over their family business. But what if her dad remained stubborn to the end NE?' (Rickshaw Boy)

³⁸My summary of Wu's claim is adapted from Li's (2006: 18) translation. I have replaced Li's (2006) use of *theme* and *rheme* with *topic* and *focus*.

³⁹My summary of Li's generalization is adapted from Chu's (2006: 9) partial translation. I translate Chu's (2006) 主位 'theme' and 述位 'rheme' as *topic* and *focus*.

Beyond *if*-antecedents, we find that all the same kinds of phrases that can occur with topic-marking *-ne* can also occur with fragment question *-ne*. More concretely, the following implication appears to be robust.

- (51) Whenever a topic can be marked with topic-marking *-ne*, it could also license a fragment question with *-ne* in exactly the same context.

For example, we can rewrite the attested use of topic-marking *-ne* in (52) as the dialogue with fragment question *-ne* in (53).⁴⁰

- (52) (In Xiángzi's eyes, Mr. Cáo was like Confucius.)

其实 呢, 曹先生 并 不 怎么 高明。
 Qíshí **ne**, Cáo-xiānsheng bìng bù zěnmē gāomíng.
 actually CT Cáo-mister on.contrary not how wise

‘(But) in reality NE, Mr. Cáo wasn’t really so wise.’ (Rickshaw Boy)

- (53) A: In Xiángzi's eyes, Mr. Cáo was like Confucius.

B: 其实 呢?
 Qíshí **ne**?
 actually CT

‘(And) in reality NE?’

A: Mr. Cáo wasn’t really so wise. (elicited)

Furthermore, as with topic-marking *-ne*, fragment question *-ne* is illicit marking *because*-clauses, which is predicted on the view these clauses make bad CTs. When a fragment question is formed from a *because*-clause, only the yes-no particle *-ma* is possible, as in (54a). The question in (b) shows that a minimally differing *if*-clause accepts *-ne*.

⁴⁰For a similar minimal pair with *qíshí* ‘actually’, see Wu (2006: 70).

- (54) a. 因为 他 不 愿意 { 吗 | #呢 }?
 Yīnwèi tā bú yuànyì { ma | #ne }?
 because he not willing Y/N CT
 ‘Because he’s not willing?’ (e.g. Is that why?)
- b. 要是 他 不 愿意 呢?
 Yàoshi tā bú yuànyì ne?
 if he not willing CT
 ‘(And) if he’s not willing NE?’ (e.g. What will we do in that case?)
 (elicited)

On the basis of the above examples, one might suspect that *-ma* is used whenever the implicit question being asked is a yes-no question, and *-ne* is used otherwise. If this were true, it would support the common but erroneous view that *-ne* is a wh- question marker, just as *-ma* is a yes-no marker (cf. Cheng 1991: 21 and others following). However this is not the case:

- (55) 我 喜欢。 你 { 呢 | #吗 }?
 Wǒ xǐhuan. Nǐ { ne | #ma }?
 I like you CT Y/N
 ‘I like it. What about you?’ (Do you like it?) (elicited, cf. Wu 2006: 67)

More generally, it appears that fragment questions use *-ma* whenever the fragment is put forward as a (suggested) exhaustive answer to a question. In other words, the question “XP *-ma*?” can be paraphrased as “Is it XP?”. By contrast, *-ne* is used whenever the fragment defines what the question being asked is about, rather than providing a potential answer. The following examples show two more cases where *-ma* is licensed but *-ne* is impossible:

(56) Context: Finding that Coke has been spilled on my book...

谁干的? 你 { 吗 | #呢 }, 老李?
Shéi gàn de? Nǐ { **ma** | #**ne** }, lǎo-Lǐ?
who do DE you Y/N CT old-Lǐ

‘Who did this? Was it you, Lǐ?’ (elicited, cf. Lin 1984: 221)

(57) Context: Someone knocks on the door. I yell from inside...

张三 { 吗 | #呢 }? 是你吗?
Zhāngsān { **ma** | #**ne** }? Shì nǐ ma?
Zhāngsān Y/N CT be you Y/N

‘Zhāngsān? Is that you?’ (elicited)

In the right context, it is possible for a fragment question to suggest an exhaustive answer to a salient question, while simultaneously contrasting with other questions—trying out different exhaustive answers one by one. Here, we might expect to be able to use a CT marker to indicate that each suggestion is a sub-question of the larger issue. Consider the following example, where speaker B runs through a list of possible answers to the question of who is behind the door.⁴¹

(58) Context: B knocks on A’s door. A yells from inside...

A: Zhāngsān, is that you? B: How could it be Zhāngsān?

A: Then is it Lǐsì? B: No, not Lǐsì either.

A: Then could it be Wáng’èr? B: Still wrong!

A: 那 王五 { 吗 | ?呢 }?
Nà Wángwǔ { **ma** | ?**ne** }?
then Wángwǔ Y/N CT

‘Then Wángwǔ?’ (elicited)

⁴¹For reference, the complete dialogue I used to elicit judgments was: 小王么? 怎么会是小王呢? 那是小张么? 不对! 那... 会不会是小林? 还是不对! 那小李呢?

Judgments on this use of *-ne* vary. Some consultants found (58) acceptable, reporting that *-ne* emphasizes that speaker A is asking whether *this* guess, as opposed to all the other guesses is correct. Other consultants found this use of *-ne* strange. It may be that for some speakers, when there is competition between a form with *-ma* and a form with *-ne*, the possibility of *-ma* rules out what would otherwise be an acceptable use of *-ne*.

In any case, we can maintain—in line with the claims of Li (2001) and Wu (2006)—that fragments marked with *-ne* are topics. However, mere topic-hood is not a sufficient condition for *-ne* to be licensed. Just as we saw with topic-marking *-ne*, fragment question *-ne* resists marking *non-contrasting* topics. In (59), Antarctica is not being suggested as an answer to any question, and hence is strange with *-ma*.⁴² Rather, it is the topic of discussion, and the topic of the question being asked, which we might paraphrase as “What can I tell you about Antarctica?”. However crucially, there is no contrasting question in the discourse, and hence no contrasting topic. The fact that *-ne* is impossible here indicates that *-ne* is more than a topic marker, it is a CT marker. Thus, fragment questions with *-ne* are not merely “thematic” questions, but are more specifically CT questions.

(59) Context: The opening line of a book called *Antarctica*.

南极洲	{ ??吗 #呢 }?	不是	一个	容易	形容	的	地方。	
Nánjízhōu	{ ?? ma # ne }?	Bú-shì	yī-gè	róngyì	xíngróng	de	dìfang.	
Antarctica	Y/N CT	not-be	one-CL	easy	describe	DE	place	
		‘Antarctica? It’s not an easy place to describe.’						(elicited)

There is one apparent exception to the claim that fragment *-ne* marks CT. In examples like (60), the speaker is asking about the whereabouts of her pen, and does not seem to imply the existence of any contrasting question about a different topic.

⁴²One speaker reports that the sentence would be acceptable with topic-marking *-me* in the place of *-ma* or *-ne*. This is evidence that not all topic-marking particles require the topic to contrast.

- (60) 我的 笔 呢?
 Wǒ-de bǐ ne?
 me-POSS pen CT
 ‘Where’d my pen go?’
 Literally: ‘My pen NE?’ (Li 2006: 67)

As Wu (2006: 74) observes, the question implied in such discourse-initial examples must be relatively simple, most often asking for the location of a misplaced item. The key point is that unlike CT examples where the discourse context contains a contrasting question, in these examples, the content of the question has to be inferred entirely from the topic itself. This can lead to misunderstandings, as in:

- (61) A: 作业 呢?
 Zuòyè ne?
 homework CT
 ‘Your homework NE?’
 B: It’s here.
 A: I was asking whether you’d finished it or not. (Wu 2006: 74)

The prospects for incorporating examples like these under a theory of CT are not promising. One could argue that the questioner in (61) has switched from some unspecified previous topic to the new topic of B’s homework. However it would be hard to maintain that there is a coherent STRATEGY (in the sense of Roberts 1996) tying the two topics together. At best, the contrasting sub-questions of this strategy would have to be defined vaguely, as in “What is the answer to the most salient question about *this* topic?”. For the time being, I will treat these examples as exceptional, and maintain that in general, non-CT topics resist *-ne*-marking, as we saw with ‘Antarctica’ in (59).

One final issue surrounding fragment questions is whether they should be analyzed as deriving from full questions via an ellipsis process. If the answer is positive, then

there is hope of explaining the use conditions of fragment questions simply in terms of (i) the use conditions of their non-elided counterparts, plus (ii) general conditions on ellipsis.

Previous work on fragments with *-ne* has usually tacitly assumed a derivational relationship between fragment questions and full questions (Tsao 2000, Chu 2006, Li 2006 and Wu 2006). For these authors, the main issue surrounding fragment questions with *-ne* is whether they derive from full questions with sentence-final *-ne*, or from full questions with topic-marking *-ne*. For instance, in the following example, does the fragment question in (a) derive from (b) or from (c)?⁴³

(62) (I know you finished *this* book...)

a. 那 本儿 书 呢?

Nèi běnr shū ne?

that CL book CT

‘(But what about) *that* book NE?’

b. 你 有没有 看完 那 本儿 书 呢?

Nǐ yǒu-méi-yǒu kàn-wán nèi běnr shū ne?

you have-not-have read-finish that CL book CT

‘(But) have you finished *that* book NE?’

c. 那 本儿 书 呢, 你 看完 了 没有?

Nèi běnr shū ne, nǐ kàn-wán le méi-yǒu?

that CL book CT you read-finish ASP not-have

‘(But) *that* book NE, have you finished?’

(Chu 2006: 13)⁴⁴

⁴³As Wu (2006: 67) points out, there are other possible underlying structures as well. For example, we could replace the question in (c) with a yes-no question formed using the sentence-final particle *-ma*.

⁴⁴While Chu writes this example with a comma as opposed to a question mark, it isn’t clear whether there is a robust dividing line between an utterance of (c) as a single sentence versus an utterance consisting of a fragment question immediately followed by the same question in full form (with the topical object pronoun dropped). This would correspond to English examples like “And you? What would you like?”.

While a traditional view held that *-ne* in fragment questions derived from question-final *-ne*,⁴⁵ the general consensus of more recent work is that this is better understood as topic-marking *-ne* (Chu 2006: 21, Li 2006: 17, Wu 2006). However, there seems not to be a great deal of strong evidence one way or the other. In fact, the main reason this question comes up in the first place is the assumption that question-final *-ne* and topic-marking *-ne* are different entities, conveying different meanings. As we will see in section §6.6, question-final *-ne* can also be analyzed as a CT marker. In this case, all three forms in (62) involve the same CT morpheme, and the difference between them is just in the syntax.

In the end, it may be that there is no general way of telling whether (a) derives from (b) or (c). It may even turn out that fragment questions are best understood as a basic syntactic form in their own right, not derivationally related to any full question.⁴⁶ The important point for us is that *-ne* in fragment questions has the same interpretation that it has elsewhere.

6.5 Expectations for Sentence-Final CT

In the examples we've discussed so far, *-ne* directly followed the CT phrase—either a sentence-initial topic, or a question fragment. In these cases, the appearance of *-ne* not only implies that we are in a contrastive topic discourse, but also tells us which phrase is the CT. And knowing which phrase is CT lets us make relatively fine-grained predictions about the shape of the surrounding discourse. Specifically, what it means for a particular phrase to be CT is that the immediate discourse addresses a

⁴⁵This traditional view is mentioned by Li (2006: 9, 17), but I have not been able to trace it to an original source. One fairly recent instance of this view is Li 2004a, who Chu (2006: 19) cites as arguing that a fragment question with *-ne* (“If she doesn’t want to go NE?”) derives from a *wh*-question where *-ne* is final (“If she doesn’t want to go, what should I do NE?”).

⁴⁶This would be somewhat surprising given the wealth of evidence that fragment answers are derived from full sentential answers via movement and ellipsis (Merchant 2005).

question about that phrase, and the larger discourse addresses contrasting questions about the various alternatives to that phrase.

But what about cases where *-ne* occurs sentence-finally? If the position of *-ne* doesn't establish which constituent is CT, what are our expectations for how these sentence-final uses should constrain the surrounding discourse? Let's take a moment to reflect on the parallel situation in English, where the CT morpheme L-H% appears sentence-finally. Consider the lone CT example in (63). On one interpretation, *Mary* is marked as a contrastive topic. We can force this interpretation with a context like (64). However, another available interpretation treats the entire sentence as CT, as in (65).

(63) I saw MARY...
 L+H* L-H%

(64) A: Did you see John and Mary?

B: I saw [MARY]_{CT}...
 L+H* L-H%

(65) A: Did anything interesting happen today?

B: [I saw MARY]_{CT}...
 L+H* L-H%

One point to take away from this example is that when the CT morpheme is sentence-final, we can expect to find indeterminacy as to which phrase is CT.⁴⁷ Of course, the position of stress can help to cut away at this indeterminacy. For example, there is no reading of (63) on which the subject or verb alone is marked as CT. Nevertheless, when an unmarked stress pattern is used, the size of the CT phrase is highly ambiguous—it could be anything from a single word to the entire sentence.

⁴⁷Similar indeterminacies can arise even when the CT morpheme is non-final, marking a sentence-initial topic. Specifically, if the topic is a complex constituent, it may be ambiguous which sub-constituent is CT.

A second moral to take away from sentential CT examples like (65) is that we shouldn't expect to always get a clear sense of what is being contrasted with the CT. In (64), where narrow CT marks the individual-denoting phrase *Mary*, it's intuitively clear that Mary is being contrasted with other people who I might have seen. In (65) however, the sense of contrast becomes more vague. By using CT, I convey that my having seen Mary is somewhat interesting, but perhaps not interesting enough to meet your standards.⁴⁸ At best, we could say that the proposition *I saw Mary* contrasts with other propositions that are relevant to resolving the issue of whether something sufficiently interesting happened.

A final point illustrated by (65) is that it is possible to be a CT without being a topic in any intuitive sense. For example, it doesn't seem insightful to assert that the sentence "I saw Mary" in (65) is about the topic *I saw Mary*.

To sum up, when we're dealing with examples that allow sentential CT readings, the contribution of CT becomes less tangible, and more prone to contextual variability. Nevertheless, as argued in chapter §2, English sentential CT still fits with the core conception of contrastive topic as conveying that the utterance addresses only one sub-part of a larger issue. In cases where the sub-issues have some structure in common—e.g. Did you see *John*? Did you see *Mary*?—we can talk of one issue as being *about* Mary, and identify Mary as a topic. In sentential CT cases, where the sub-issues are not structurally related, the sense of aboutness is lost, but the essential meaning of CT remains. For example, it is clear that (65) addresses part, but not all of the issue of whether anything interesting happened today. This non-resolution is precisely what the intonation in (65) conveys—no more and no less.

⁴⁸In terms of a discourse strategy, we can understand the question of whether anything interesting happened today as being broken down into sub-questions "Did I see Mary?" and "Does my seeing Mary count as interesting?"

Turning to Mandarin sentence-final *-ne*, we now have some concrete expectations for the kinds of discourses it will require. If Mandarin final *-ne* behaves like English final L-H%, we will find both cases where it marks a narrow CT and cases where it marks sentential CT. The latter cases will not be clear cases of “contrast” or “topic”, but are expected to address partial issues.

6.6 Question-Final *-ne*

In this section, we will look at four basic types of Mandarin questions, and consider the circumstances under which they are compatible with sentence-final *-ne*. The basic question types are as follows:

- (66) a. 你 想 喝 什么? **Wh- Question**
 Nǐ xiǎng hē shénme?
 you want drink what
 ‘What would you like to drink?’
- b. 你 想 喝 咖啡 还是 茶? **Alternative Question**
 Nǐ xiǎng hē kāfēi háishi chá?
 you want drink coffee or tea
 ‘Would you like to drink coffee or tea?’
- c. 你 想不想 喝 咖啡? **A-not-A Question**
 Nǐ xiǎng-bù-xiǎng hē kāfēi?
 you want-not-want drink coffee
 ‘Would you like to drink coffee?’
- d. 你 想 喝 咖啡 吗? **Particle Question**
 Nǐ xiǎng hē kāfēi ma?
 you want drink coffee Y/N
 ‘Would you like to drink coffee?’

The main claim I would like to make is that questions with *-ne* always presuppose a complex strategy of questions in the discourse, as we expect if *-ne* marks CT.⁴⁹ More specifically, I will argue that *ne*-final questions are either (i) contrasting sub-questions within a strategy, or (ii) complex questions denoting a strategy. These are precisely the two types of questions that were predicted to contain CT morphemes on the formal analysis of CT from section §3.3. Questions with *-ne* that don't fall under this generalization can be argued to contain a distinct morpheme *-ne* that marks durative aspect, which will be treated in section §6.8.

The availability of *-ne* is not uniform across different questions types. Overall, we will see that *-ne* is always possible on alternative questions, and nearly always possible on *wh*- questions, but quite restricted on *yes-no* questions. This distribution stems from the fact that alternative questions can always be decomposed as a strategy of *yes-no* questions. Similarly, a *wh*- question like “Who came?” can typically be broken into a string of *yes-no* questions (e.g. “Did John come? Did Mary come?”).

Mandarin *yes-no* questions primarily come in two flavors: those with the final *yes-no* particle *-ma*, and those formed with A-not-A morphology on the predicate. We will see that *yes-no* questions with *-ma* are incompatible with final CT *-ne*. I argue that this is due to a haplology constraint, rather than any semantic mismatch. By contrast A-not-A questions can be marked with *-ne*, but only under two specific circumstances. In one case, the A-not-A question is a sub-question, contrasting with another A-not-A question in the discourse. In the other case, the A-not-A question is itself interpreted as a disjunction, giving a meaning along the lines of an English *or not* question, as in “Did you do it or not?”.

⁴⁹Following the discussion from chapter §3, page 93, I continue to use the term “strategy” loosely, without committing to a particular implementation. The simplest resolution of the term takes a strategy to be a sorted question denotation. However adopting the more articulated view laid out by Roberts (1996) is another possibility.

In the following sections, we will address each of the four question types in turn. We start with alternative questions, since their support of *-ne* is the most ubiquitous. Next we briefly address yes-no particle questions, which logically ought to support *-ne* when functioning as a sub-question, but in fact never do. After that, we turn to A-not-A questions, which show a more complex pattern—supporting *-ne* on one reading equivalent to an alternative question, and another reading as a sub-question. Last of all, we’ll look at wh- questions, which follow the basic pattern observed with A-not-A questions, but are more easily construed as strategies.

6.6.1 Alternative Questions

This section looks at alternative questions, which are formed using the disjunction *háishi*.⁵⁰ These questions have the remarkable property of always supporting final *-ne*. The attested example (67) gives a first case of an alternative question where *-ne* can mark each disjunct.⁵¹

(67) 宝宝 先 叫 谁? 是 妈妈 呢? 还是 爸爸 呢?
 Bǎobao xiān jiào shéi? Shì māma ne? Háishi bàba ne?
 baby first call who be mom CT or dad CT

‘Whose name did baby say first? Was it mom NE? Or dad NE?’

(web example)

While the two alternatives in this example are represented orthographically as separate questions, it is important to recognize that neither disjunct can stand on its own as a question with *-ne*. For example, if we simply remove the second alternative as

⁵⁰We will postpone discussion of A-not-A questions until section §6.6.3, despite the fact that they pattern with alternative questions in many regards (cf. Huang et al.’s 2009: 236 assessment that “most researchers have agreed that A-not-A questions should be viewed as a special type of disjunctive question”). We will see that A-not-A questions can convey a meaning equivalent to an alternative question with *háishi*, but that this is not their only possible meaning.

⁵¹Here, as in general, individual uses of *-ne* are optional. Thus, (67) is also possible with *-ne* on just the first or just the second disjunct.

in (68), *-ne* is no longer available marking the first alternative. This is evidence for treating (67) as a single alternative question rather than two separate questions.

- (68) 宝宝 先 叫 谁? 是 妈妈 { 吗 | *呢 | *呢吗 | *吗呢 }?
 Bǎobao xiān jiào shéi? Shì māma { **ma** | ***ne** | ***ne-ma** | ***ma-ne** }?
 baby first call who be mom Y/N CT CT-Y/N Y/N-CT
 ‘Whose name did baby say first? Was it mom MA?’ (elicited)

It appears to be a robust generalization that matrix alternative questions with *háishi* can always be marked with a final *-ne*. The disjuncts, however, can only be directly marked with *-ne* under specific circumstances. Based on examples like (69), it appears that whether individual disjuncts can receive *-ne* depends on whether the disjunction is sentence-final or not. In (69a), the disjunction is final, and each disjunct can be followed by *-ne*. By contrast, in (69b) the disjunction is non-final, and *-ne* is impossible on either disjunct, regardless of whether *-ne* appears sentence-finally.

- (69) a. 他 想 娶 小王 呢 还是 小李 呢?
 Tā xiǎng qǔ Xiǎo-Wáng **ne** háishi Xiǎo-Lǐ **ne**?
 He want marry little-Wáng CT or little-Lǐ CT
 ‘Does he want to marry Wáng NE or Lǐ NE?’
- b. 他 想 跟 小王 (*呢) 还是 跟 小李 (*呢) 结婚 (呢)?
 Tā xiǎng gēn Xiǎo-Wáng (***ne**) háishi gēn Xiǎo-Lǐ (***ne**) jiéhūn (**ne**)?
 He want with little-Wáng CT or with little-Lǐ CT marry CT
 ‘Does he want to marry Wáng or Lǐ?’
 Literally: ‘He wants to with Wáng or with Lǐ marry (NE)?’ (elicited)

There are two main facts that need explaining here. First, why is *-ne* always possible at the end of alternative questions, and second, why is *-ne* also available marking disjuncts, but with syntactic restrictions. Treating *-ne* as CT lets us make immediate progress on these questions. Recall from section §3.3 that the analysis of CT as encoding topic abstraction led to the prediction that CT will be possible in two types

of questions: (i) strategy-denoting questions, and (ii) sub-questions within a strategy. As Han and Romero (2004: 599, fn. 14) note, in the same way that a *wh*-question like “Which student came?” can be broken into a strategy of yes-no questions { Did John come? Did Sue come? Did Bill come? ... }, an alternative question can be treated as a strategy of contrasting yes-no questions, where each alternative is a sub-question. If this is so, then the analysis of CT from section §3.3 predicts that a CT morpheme should be able to mark an entire alternative question.

The question of when *-ne* can appear on disjuncts is more complicated, but also fits with the overall picture of *-ne* as CT. On the analysis from section §3.3, CT is predicted to occur on sub-questions within a strategy. It seems initially plausible to say that each occurrence *-ne* in (69a) marks a constituent denoting a sub-question. This would hold, for example, if (69a) were generated as a disjunction of two interrogative clauses with ellipsis in the second clause, as on the analysis of alternative questions given by Pruitt and Roelofsen (2011), building on work by Han and Romero (2004). However, the contrast between (69a) and (69b) still remains to be explained. A satisfactory account of this contrast would require a deeper look at the syntax and semantics of Mandarin alternative questions. One possibility is that in (69b), the disjunction occurs low enough in the structure that the disjuncts cannot denote questions, thereby explaining the absence of *-ne*. However I leave this issue open here.

While the syntactic restrictions remain to be explained, the behavior of *-ne* in alternative questions is still broadly supportive of an analysis in terms of CT. The core claim is that since alternative questions are complex strategies of contrasting yes-no questions, they satisfy the basic licensing requirements for CT without the need for any additional contextual support. Their multi-question meaning allows them to be marked as super-questions, and (depending on syntactic factors) allows their disjuncts to be marked as sub-questions.

Beyond always being possible in alternative questions, *-ne* is actually quite frequent in these questions, when they occur. In *Rickshaw Boy*, the entire novel only contains two root alternative questions with *háishi*, but each of them contains *-ne* on at least one alternative:⁵²

(70) (He couldn't remember ever feeling this hot before.)

是 天气 比 往年 热 呢, 还是 自己的 身体 虚 呢?
 Shì tiānqì bǐ wǎng-nián rè **ne**, háishì zìjǐ de shēntǐ xū **ne**?
 be weather COMP former.year hot CT or self POSS body weak CT
 'Was the weather hotter than in past years NE, or was he getting weaker NE?'
 (*Rickshaw Boy*)

(71) (I'll just say it... I'm pregnant, and it's Xiangzi's. Wherever he goes, I go.)

你 是 把 我 给 他 呢? 还是 把 我们 俩 一齐 赶出去?
 Nǐ shì bǎ wǒ gěi tā **ne**? Háishì bǎ wǒmen liǎ yīqí gǎn-chū-qù?
 you be BA me give him CT or BA us two both drive-out-go
 'So will you let me go with him NE? Or are you going to throw us both out?'
 (*Rickshaw Boy*)

Compared to alternative questions, *wh*- questions are more frequent overall, but display *-ne* a smaller proportion of the time. For example, Shi's (1997: 133) investigation of a small corpus found that only around 5% of *wh*- questions were marked with *-ne*.⁵³ This contrast between alternative and *wh*- questions supports the idea that alternative questions are by their nature automatically compatible with CT, whereas *wh*-

⁵²Additionally, of 11 embedded alternative questions with *háishi*, two contain *-ne* on at least one alternative.

⁵³The corpus consisted of the full text of Cáo Yǔ's (曹禺) 1933 play *Thunderstorm* (雷雨). The play is written in a colloquial style, and shows heavy use of *-ne*, with the particle occurring 114 times in total. However out of 367 *wh*- questions, Shi (1997) observes that only 19 have *-ne*.

questions need to satisfy additional discourse requirements to support CT.⁵⁴ We will return to these requirements in section §6.6.4.

One important remaining question is why it appears (so far) that *-ne* only marks contrasting yes-no questions when they occur as alternatives within an overt alternative question. Specifically, why was *-ne* impossible when we isolated one alternative and asked it as an independent question, as in (68)? In general, CT morphemes can signal contrasts with *implicit* questions, so why in this case should the sub-questions have to be explicitly combined into a single questioning act? In the next section, I argue that sentences like (68) do in fact license CT. But while CT *-ne* is formally licensed, there is a phonological constraint against realizing the particle when the final yes-no question particle *-ma* is present.

6.6.2 Particle Questions

Mandarin has two common strategies for forming yes-no questions (loosely construed) (Li and Thompson 1979). The first uses the final yes-no question particle *-ma*, as in (72a). The second uses the A-not-A structure shown in (72b).

(72) a. 你 喜欢 他 吗?
 Nǐ xǐhuan tā **ma**?
 you like him Y/N
 ‘Do you like him?’

b. 你 喜欢不喜欢 他?
 Nǐ **xǐhuan-bù-xǐhuan** tā?
 you like-not-like him
 ‘Do you like him?’

(Li and Thompson 1979: 197)

⁵⁴The idea that final *-ne* in wh- questions carries additional meaning—contra Cheng’s (1991: 21) claim that *-ne* merely indicates wh- question clause type—has been defended by a range of authors, including Hu (1981), Li and Thompson (1981), Lin (1984), Shao (1989, 1996), Chu (1998, 2006) and Li (2006). We will see some of their arguments in section §6.6.4.

In this section, we focus on yes-no questions like (a) that are formed by adding a particle to a plain declarative form. I will refer to such questions as PARTICLE QUESTIONS, following Huang et al. (2009: 236). In fact, particle questions quite generally resist *-ne*. That is, *-ne* can neither turn a declarative into a question on its own, nor can it co-occur with particles that do. We saw one instance of this incompatibility already in (68). Let's turn to another example. An ideal yes-no question for licensing CT would be one that contrasts with an explicit sister yes-no question in the immediate context. For example, if I've just asked a question about whether someone else can dance, as in (73), a following question about whether *you* can dance should be easy to understand as a contrasting question with 'you' as CT.

- (73) A: 他 会 跳舞 吗?
 Tā huì tiàowǔ ma?
 he can dance Y/N
 'Can he dance?'
- B: 他 不 会。
 Tā bú huì.
 he not can
 'No he can't.'

In this context, both fragment and A-not-A questions support *-ne*, as shown in (74). This is expected on the view that *-ne* marks CT. However a particle yes-no question in the same context can only use the particle *-ma*. As (75) shows, the addition or substitution of *-ne* is impossible.

- (74) a. 你 呢?
 Nǐ **ne**?
 you CT
 ‘(And) you NE?’
- b. 你 会不会 呢?
 Nǐ huì-bú-huì **ne**?
 you can-not-can CT
 ‘Can you NE?’ (elicited)
- (75) 你 会 { 吗 | *呢 | *呢吗 | *吗呢 }?
 Nǐ huì { ma | *ne | *ne-ma | *ma-ne }?
 you can Y/N CT CT-Y/N Y/N-CT
 ‘Can you MA?’ (elicited)

Cross-linguistically, there is no constraint against a CT particle appearing in a yes-no question with a final question particle. For example, Japanese CT *-wa* can appear in a yes-no question like (76), along with the question particle *-ka*. So, if Mandarin *-ne* is a CT morpheme, what is wrong with (75)?

- (76) (John can play the violin.)
 Anata-wa deki-masu-ka?
 you-CT can-polite-Q
 ‘Can you?’ (elicited)

I would like to propose that the problem with *-ne* in (75) is only surface deep. The CT particle *-ne* is licensed as far as its meaning, and we can even maintain that it is (optionally) underlyingly present in (75). However, it can't be realized adjacent to the particle *-ma*. We can see this incompatibility as the result of a haplology constraint, formalized as follows:

(77) **Haplology:** $/-ne_{CT} + -ma/ \rightarrow -ma$

When CT *-ne* and yes-no *-ma* morphemes co-occur, only *-ma* is pronounced.

This type of constraint is familiar from the behavior of other particles in Mandarin. For example, Li and Thompson (1981: 298–300) discuss cases like (78) where two homophonous morphemes (perfective *-le* and “currently relevant state” *-le*) can’t surface together, despite both being semantically licensed.⁵⁵ In section §6.8, we will also see a similar constraint preventing durative *-ne* and CT *-ne* from surfacing together.

- (78) 火 灭了 (*了)。
Huǒ miè-**le** (***le**).
fire go.out-PFV ASP

‘The fire went out, and that is what I have to say.’

(Li and Thompson 1981: 299–300)

While these cases of haplology in Mandarin target *identical* syllables, haplology constraints are also known to target similar but non-identical material. For example, Stemberger (1981: 802) discusses cases showing “variability in the degree of morphological and phonological similarity required [for haplology to occur]”. One case particularly resembling our constraint in (77) is discussed by Skopeteas (2010). Across a range of Mayan languages, “whenever more than one interpretable clitic is licensed within the same intonational phrase, then a rule of haplology bans the concatenation of multiple clitics on the right edge” (Skopeteas 2010: 323). Examples from Yucatec Maya (p. 324) show that in cases where we would expect the clitics =*a*’ and =*o*’ to appear together sentence-finally, only one surfaces.

Returning to the Mandarin facts, the restriction against *-ne* and *-ma* co-occurring has been widely noted, although there is no generally accepted explanation for it.

⁵⁵See also Chao 1968: 247 for an earlier instantiation of the same analysis, and further evidence supporting it.

Several authors claim or imply that the two particles are strictly incompatible. This position is taken explicitly by Li and Thompson (1981: 306), and is implied by Cheng (1991: 21) and Li (2006: 13). These authors adopt the view that the types of questions marked by *-ne* and *-ma* are grammatically distinct. For example, according to Li and Thompson (1981: 306), *-ma* is restricted to “plain” yes-no questions (without any additional question morphology), while *-ne* marks wh- questions, A-not-A questions, and fragment questions.

Although there are several challenges for this particular view (forcing us to reject the notion of *-ne* as a non-yes-no question marker), I will hold onto the basic idea that *-ne* and *-ma* are fundamentally incompatible. More specifically, I claim that anywhere *-ma* would be licensed, CT *-ne* is impossible. (We will see that aspectual *-ne* behaves slightly differently.) This complementary distribution falls out from the haplology constraint in (77), when combined with the generalization that *-ma* is mandatory in yes-no questions that contain no other question morphology.⁵⁶

One important challenge to the common view that *-ne* and *-ma* mark different clause types is that, as Lin (1984: 221) points out, fragment questions can occur with either *-ma* or *-ne*, as we saw in section §6.4. The difference between these uses comes down just to whether the fragment is a contrastive topic or an exhaustive focus, so it would be hard to explain as a difference in clause type (cf. Cheng 1991). However, if *-ne* marks a fragment as CT, as argued in §6.4, then there is room for a principled account of why some fragments get *-ma* and others get *-ne*.⁵⁷

⁵⁶This generalization, stated by Lin (1984: 220) as a rule, is not without its exceptions. See Shen (1990: §2) for counter-examples to this claim, and the distinctive prosody they carry. I suspect that these rising declaratives have a fairly limited distribution, and are licensed by specific discourse conditions. (This would be in line with English rising declaratives; see Gunlogson 2008.) For this reason, I have ignored their presence, and work with the approximation that *-ma* is mandatory.

⁵⁷Presumably *-ma* fragment questions derive from full interrogatives containing the final particle *-ma*, with elision of all non-focused material within the clause. However the syntactic analysis of *-ne* fragments is less clear. As we saw in section §6.4, it isn't certain whether *-ne* in fragments derives from sentence-final *-ne* or from topic-marking *-ne*. In either case, the key point is that *-ne* in fragments marks the fragment phrase as a contrastive topic. This at least explains why *-ne* can't

There are two more serious challenges to claim that *-ne* and *ma* are in complementary distribution. First we see the occasional appearance of *-ne* in yes-no questions without A-not-A structure, as in the following example:⁵⁸

- (79) 跟 舅舅 还 保密 呢?
 Gēn jiùjiu hái bǎomì ne?
 with uncle still keep.secret DUR
 ‘Are you still keeping it a secret from uncle NE?’ (Li 2004b: 37)

Second, we find examples of *-ne* and *-ma* together, as observed by Lin (1984: 218), Gasde (2004: 317) and Li (2004b: 43):⁵⁹

- (80) 你 没 看见 我 手里 做着 活 呢 吗?
 Nǐ méi kànjiàn wǒ shǒu-li zuò-zhe huó ne ma?
 you have.not see my hand-LOC do-DUR work DUR Y/N
 ‘Didn’t you see that I’m working NE MA?’ (Ōta 1987: 344)

These data can be used to argue against the claim that *-ne* and *-ma* are simply question markers for different types of clause. However, our present concern is that they are equally problematic for the claim that *-ne* uniformly marks CT. In particular, the meanings and contexts of (79), (80) and similar examples confirm that these questions are not being construed as CT questions.

To understand these data, we need to draw a distinction between aspectual *-ne* and CT *-ne*. The full case for recognizing a distinct aspectual *-ne*, following Chan (1980), is presented in section §6.8, and is necessary independent of the facts discussed above. For now, we can just observe that the problematic examples above involve durative predicates (‘doing work’ and ‘keeping a secret’) that are viewed as ongoing at the

be used when the fragment is an exhaustive focus. Explaining why *-ma* is unable to mark a CT fragment is a more challenging question which I leave unresolved.

⁵⁸This example is from the mainland TV series *The Grand Mansion Gate* (大宅门).

⁵⁹This example comes from the 19th century novel *The Gallant Maid* (儿女英雄传).

time being discussed. This will be the crucial licensing factor for aspectual *-ne*. With these examples out of the way, we can maintain that CT *-ne* is impossible in particle questions across the board.

One final caveat involves examples like (81) that look superficially like particle questions using CT *-ne*. But in fact, (81) should be analyzed as a fragment question. What appears to be a matrix clause is actually a bare *if*-antecedent, parallel to the *if*-clause in (82), where the word *yàoshi* ‘if’ is optional.

- (81) 有 人 不 同 意 呢?
 Yǒu rén bù-tóngyì **ne**?
 have person not-agree CT
 ‘(And) what if someone disagrees?’
 Literally: Someone disagrees NE? (Alleton 1981: 100)

- (82) (要是) 有 人 不 同 意 怎 么 办?
 (Yàoshi) yǒu rén bù-tóngyì zěnmē bàn?
 if have person not-agree how manage
 ‘If someone disagrees, what will we do?’ (elicited)

The analysis of (81) as a fragment question built on a conditional antecedent is necessitated by its meaning. A true particle question using this matrix clause would convey a simple yes-no meaning, with no conditional flavor:

- (83) 有 人 不 同 意 吗?
 Yǒu rén bù-tóngyì **ma**?
 have person not-agree Y/N
 ‘Does anyone disagree?’ (Alleton 1981: 100)

In summary, CT *-ne* is incompatible with questions formed by adding a particle to a declarative base. This incompatibility is unexpected, given that these questions work in CT discourses, as we saw in (75). However a plausible account in terms of

haplogy gave us a way of understanding why *-ne* might not be able surface, even when its meaning contribution would be licensed.

6.6.3 A-not-A Questions

This section looks at the distribution of *-ne* in A-not-A questions. Unlike alternative questions, these questions do not automatically license *-ne*. Rather, when *-ne* occurs, specific discourse conditions must hold. I argue that A-not-A questions have two interpretations, which I will refer to as MONOPOLAR and BIPOLAR. There are two main claims to be defended. First, monopolar A-not-A questions with *-ne* need to contrast with another monopolar question in the discourse. Second, bipolar A-not-A questions pattern with alternative questions, licensing *-ne* without any contrasting question in the discourse.

Before looking at *-ne*, it will be useful to establish some basic properties of A-not-A questions. Mandarin A-not-A questions are formed by reduplicating the lexical head of the predicate (typically a verb) and adding a negative morpheme between the reduplicant and the base. The negation is expressed by either *bù* or *méi*, depending on tense and aspect of the predicate. Also, depending on various lexical and stylistic factors which will not concern us here, the reduplication may either target the entire head as in (84a), or just copy the first syllable as in (84b).

(84) a. 他 喜欢不喜欢 这 本儿 书?
 Tā **xǐhuan**-bù-xǐhuan zhèi běnr shū?
 he like-not-like this CL book
 ‘Does he like this book?’

b. 他 喜不喜欢 这 本儿 书?
 Tā **xǐ**-bù-xǐhuan zhèi běnr shū?
 he like-not-like this CL book
 ‘Does he like this book?’

(Huang 1991: 306)

In terms of their distribution, A-not-A questions pattern neither uniformly with yes-no *-ma* questions, nor uniformly with alternative *háishi* questions. Let's start by looking at several differences between A-not-A and *-ma* questions.⁶⁰ First, unlike *-ma* questions, A-not-A question can only be answered with one of the two alternatives, not with the fixed expressions *shì* 'yes', *bù* 'no', or *duì* 'right' (Hagstrom 2006: 174). Second, as Li and Thompson (1979: 201–205) observe, *-ma* questions can be used in contexts biased toward one of the alternatives, as in (85), whereas A-not-A questions resist these contexts:⁶¹

(85) Context: I've always known that you don't eat apples. One day, I'm surprised to see you eating an apple for dessert. Puzzled, I ask...

- a. 你 吃 苹果 吗?
 Nǐ chī píngguǒ ma?
 you eat apple Y/N
 'You eat apples?'

- b. #你 吃不吃 苹果?
 #Nǐ chī-bù-chī píngguǒ?
 you eat-not-eat apple

(Li and Thompson 1979: 201–202)

Third, as Cheng et al. (1996: 100) observe, *-ma* questions are odd with the adverb *dàodǐ* 'in the end', while A-not-A questions typically support it.⁶² This contrast is illustrated by the pair in (86). The translation as 'really' doesn't quite do justice to the sense of *dàodǐ*. In the words of Huang et al. (2009: 237), *dàodǐ* "expresses an

⁶⁰For discussion of additional differences, see Zhang (1997: §4.2.2) and the appendix of Cheng et al. (1996).

⁶¹Specifically, Li and Thompson's (1979: 202) claim is that A-not-A questions are illicit in contexts where the questioner brings to the speech situation an assumption about the truth or falsity of the proposition.

⁶²Both Cheng et al. (1996: 100) and Zhang (1997: 108) mark such *-ma* questions as ungrammatical. However, speakers I have consulted do not reliably find them completely unacceptable. Additionally, examples like (i) are attested online. At the very least, we can maintain that A-not-A questions are much more readily compatible with *dàodǐ* than their *-ma* question counterparts.

urgent desire, even a sense of impatience, on the part of the speaker to get to the specific information being requested.”

- (86) a. 他 到底 吃不吃 肥肉?
 Tā dàodǐ chī-bù-chī féi-ròu?
 he in.the.end eat-not-eat fatty-meat
 ‘Does he really eat fatty meat?’
- b. ??他 到底 吃 肥肉 吗?
 ??Tā dàodǐ chī féi-ròu ma?
 he in.the.end eat fatty-meat Y/N
 Intended: ‘Does he really eat fatty meat?’ (Zhang 1997: 108)

In all three of these respects, A-not-A questions pattern with alternative questions.⁶³ However there are equally important differences between A-not-A and alternative questions. First, as Huang (1982b, 1991) observes, A-not-A questions are unlike alternative *háishi* questions in that they can’t appear inside islands for movement:

- (87) a. 我 去 美国 还是 不去 比较 好?
 Wǒ qù Měiguó háishi bú-qù bǐjiào hǎo?
 I go America or not-go more good
 ‘Is it better that I go to America or not?’
- b. *我 去不去 美国 比较 好?
 *Wǒ qù-bú-qù Měiguó bǐjiào hǎo?
 I go-not-go America more good (Huang 1991: 313–314)

-
- (i) 你 到底 爱 我 吗?
 Nǐ dàodǐ ài wǒ ma?
 you in.the.end love me Y/N
 ‘Do you really love me?’

(web example)

⁶³Specifically, alternative questions can’t be answered with particles *shì* ‘yes’, *bù* ‘no’, or *duì* ‘right’, and the judgments of (85b) and (86a) are the same if the questions are changed from [V-not-V O] into [V O or not V] using *háishi* ‘or’ and *bù* ‘not’.

More importantly for our purposes, we also find contexts of the opposite kind, where A-not-A questions are licensed but alternative questions are not. These are roughly those contexts identified by Bolinger (1978) as accepting standard English yes-no questions but rejecting explicit alternative questions with *or not*.⁶⁴ The following contrasts (adapted from Biezma 2009) illustrate:

- (88) a. *A sincere marriage proposal...*
 Will you marry me (#or not)? **Request**
- b. *Your friends arrive at your house...*
 Do you want something to drink (#or not)? **Invitation**
- c. *Trying to start a casual conversation...*
 Do you like to play golf (#or not)? **Conversation Starter**

In these same contexts, Mandarin A-not-A questions are licensed, while alternative questions with *háishi* are not. For instance, the A-not-A questions in (89) make natural invitations, requests and small talk. By contrast, the alternative questions in (90) can't serve these functions. Rather, they are judged as making an aggressive demand for an answer, and this demand stands in conflict with any genuine goal of inviting, requesting, or making chit-chat. This judgment mirrors what Biezma (2009) terms the CORNERING effect of English alternative questions with *or not*. I have indicated these judgments by including *or not* in the translations for (90).

⁶⁴In fact, only a subset of Bolinger's contexts can be used to draw out the contrast between A-not-A and alternative questions in Mandarin. This is because, as we saw earlier, A-not-A questions are themselves already restricted against appearing in biased contexts, unlike English yes-no questions.

- (89) a. 你 愿不愿意 嫁 给 我?
 Nǐ yuàn-bú-yuànyì jià gěi wǒ?
 you willing-not-willing marry to me
 ‘Will you marry me?’
- b. 你 想不想 进来 坐 一 会儿?
 Nǐ xiǎng-bù-xiǎng jìn-lái zuò yī huìr?
 you want-not-want enter-come sit a while
 ‘Do you want to come in for a bit?’
- c. 你 喜不喜欢 看 篮球?
 Nǐ xǐ-bù-xǐhuan kàn lánqiú?
 you like-not-like watch basketball
 ‘Do you like to watch basketball?’ (elicited)
- (90) a. 你 (是) 愿意 还是 不愿意 嫁 给 我?
 Nǐ (shì) yuànyì **háishi** bú-yuànyì jià gěi wǒ?
 you be willing or not-willing marry to me
 ‘Will you marry me or not?’
- b. 你 (是) 想 还是 不想 进来 坐 一 会儿?
 Nǐ (shì) xiǎng **háishi** bù-xiǎng jìn-lái zuò yī huìr?
 you be want or not-want enter-come sit a while
 ‘Do you want to come in for a bit or not?’
- c. 你 (是) 喜欢 还是 不喜欢 看 篮球?
 Nǐ (shì) xǐhuan **háishi** bù-xǐhuan kàn lánqiú?
 you be like or not-like watch basketball
 ‘Do you like to watch basketball or not?’ (elicited)

Several authors, including Buring (2003), Biezma and Rawlins (2012) and Krifka (to appear) rely on a formal distinction between yes-no questions built on one alternative and those built on two. Here I’ll adopt Krifka’s (2013) terminology and use the terms MONOPOLAR and BIPOLAR for these two question types. Let’s assume further, following Biezma and Rawlins (2012), that the cornering effect in examples like (90)

derives from the bipolar meaning of the question. In that case, we can conclude that A-not-A questions allow monopolar meanings.⁶⁵

Let's now consider the effect of adding *-ne* to A-not-A questions. Remarkably, adding *-ne* to the questions in (89) results in questions that are roughly equivalent to the explicit alternative questions with *háishi*.⁶⁶ For instance (91a) is judged strange as a sincere marriage proposal, and has a somewhat confrontational feel.⁶⁷ Again, I indicate this cornering meaning with *or not* in the translations.

- (91) a. 你 愿不愿意 嫁 给 我 呢?
 Nǐ yuàn-bú-yuànyì jià gěi wǒ **ne**?
 you willing-not-willing marry to me CT
 'Will you marry me or not?'
- b. 你 想不想 进来 坐 一 会 儿 呢?
 Nǐ xiǎng-bù-xiǎng jìn-lái zuò yī huìr **ne**?
 you want-not-want enter-come sit a while CT
 'Do you want to come in for a bit or not?'
- c. 你 喜不喜欢 看 篮球 呢?
 Nǐ xǐ-bù-xǐhuan kàn lánqiú **ne**?
 you like-not-like watch basketball CT
 'Do you like to watch basketball or not?' (elicited)

⁶⁵Incidentally, yes-no questions with *-ma* are equally possible in Bolinger's monopolar-inducing contexts. To take one example, the following *-ma* question is a natural marriage proposal:

- (i) 你 愿意 嫁 给 我 吗?
 Nǐ yuànyì jià gěi wǒ ma?
 you willing marry to me Y/N
 'Will you marry me?' (elicited)

⁶⁶The idea that A-not-A questions allow an interpretation that is semantically equivalent to an alternative question follows in the spirit of Huang (1991: 318) who points out that alternative question interpretations can be generated even without *háishi* in cases like *Tā chī fàn chī miàn?* 'Does he want rice or noodles?'

⁶⁷One speaker reported a sense of confrontation. Another speaker reported the sentence is not necessarily confrontational, but has a flavor of negotiation, and implies that either the yes or no answer is acceptable. This seems broadly consistent with the view that *-ne* is forcing a bipolar question reading.

More concretely, the questions in (90) and (91) are appropriate in contexts where the speaker is frustrated by not having been able to get a satisfactory answer out of the interlocutor so far. For instance a perfect context for (90a) and (91a) would be the dialogue leading up to the bipolar question in the following exchange:

(92) A: Will you marry me?

B: Well, I do like you a lot... although I'm not sure that I'm ready for that kind of commitment... but then again, it would get us a tax break...

A: Look, will you marry me or not!?

These facts fall out naturally on the view that *-ne* marks CT. Specifically, given the analysis of CT in questions from section §3.3, we predict that *-ne* should be licensed in (91) only under two circumstances. One would be that the marked question contrasts with another yes-no question. However the contexts we've considered so far haven't provided any support for this reading. The other possibility is that the marked question is itself interpreted as a strategy of questions—in this case, an alternative question. The overall prediction then is that an A-not-A question with *-ne* will be always be interpreted as a (cornering) alternative question, unless there is contextual support for interpreting it as a contrasting sub-question. (We will return to examples of the latter kind shortly.)

The ability of CT to force a bipolar reading of a yes-no question is a welcome explanation for a common observation about *-ne* from the Chinese literature. Many authors have noted that final *-ne* often marks questions of “intense inquiry” (深究) (Shao 1989, 1996; Xiong 1999; Li 2006: 14–16). For example, Shao (1996: 30) observes that compared to their counterparts without the particle, certain questions with *-ne* have (in my translation) “an additional layer of meaning of ‘getting to the bottom of the issue’ (追根寻底), equivalent to adding *dàodǐ* or *jiūjìng*.” These adverbs mean roughly ‘when all's said and done’, ‘after all’, or ‘in the end’. In questions, the meaning of *dàodǐ* has been compared with English *the hell* (Huang and Ochi 2004)

and *on earth* (Cheng et al. 1996: 100) as in “Where { the hell / on earth } are they?”. I would argue that the core feature of these paraphrases of *-ne* is the sense of needing to get to a *final* answer after considering various options. For example, we see this progression explicitly in (93), where the speaker has established various places that *don't* answer the question under discussion, but is still looking for the correct answer.

(93) (The kids aren't at school. And they're not at home.)

他们 到底 在 哪儿 呢?
 Tāmen dàodǐ zài nǎr **ne**?
 they in.the.end at where CT

‘Where (the hell) are they?’ (elicited)

Regardless of the form of a question (wh-, alternative, or A-not-A), it appears that any matrix question with *dàodǐ* supports the addition of final *-ne*.^{68,69} On A-not-A questions in particular, we can understand the affinity of *-ne* for *dàodǐ* in terms of the fact that *dàodǐ* forces bipolar readings. Recall from above the observation from Cheng et al. (1996: 100) that *dàodǐ* is incompatible with monopolar *-ma* questions. Furthermore, observe that *dàodǐ* A-not-A questions are odd in contexts requiring monopolar questions (as I indicate with *or not* in the translation):

⁶⁸To the limited degree that *-ma* questions can take *dàodǐ*, as in the attested example (i), these questions resist *-ne*. This is as expected on the haplology account from the previous section, §6.6.2.

(i) 你 到底 爱 我 吗?
 Nǐ dàodǐ ài wǒ ma?
 you in.the.end love me Y/N

‘Do you really love me, when all's said and done?’ (web example)

⁶⁹Embedded questions generally resist CT *-ne*, as we'll discuss in more detail in chapter §7. Thus, for example, the following embedded question with *dàodǐ* doesn't support *-ne*:

(i) 他 想 知道 你 到底 去了 哪儿 (*呢)。
 Tā xiǎng zhīdao nǐ dàodǐ qù-le nǎr (***ne**).
 he want know you in.the.end go-PFV where CT

‘He wonders where on earth you've been (*NE).’ (elicited, cf. Huang et al. 2009: 241)

- (94) 你 到底 愿不愿意 嫁 给我?
 Nǐ dàoǐ yuàn-bú-yuànyì jià gěi wǒ?
 you in.the.end willing-not-willing marry to me
 ‘So will you marry me or not?’ (elicited)

The overall picture then is that *dàoǐ* forces bipolar readings of A-not-A questions, and—like explicit alternative questions—these always support *-ne*, since they can be broken up as a strategy of sub-questions. In fact, beyond always allowing *-ne*, questions with *dàoǐ* are like alternative questions in that they display *-ne* a high proportion of the time. For example *Rickshaw Boy* contains five unembedded questions with *dàoǐ*, and two of these have a final *-ne*.

So far, the examples of *-ne* in A-not-A questions we’ve considered have all been bipolar (cornering) questions—or in Shao’s (1989) terms, questions of intense inquiry. However CT alone should not force a bipolar reading. Rather, the CT analysis predicts that *-ne* should also be possible on monopolar questions, just in case the question is interpreted as a sub-question within a larger strategy of yes-no questions. This prediction is borne out in examples of the following kind:

- (95) 你 懂 了, 他 懂不懂 呢?
 Nǐ dǒng le, tā dǒng-bù-dǒng **ne**?
 you understand ASP he understand-not-understand CT
 ‘You understand now... (but) does *he* understand NE?’ (Chao 1968: 802)

The following example is a similar case, showing furthermore that the same kind of A-not-A question that rejects *-ne* out of the blue, can license *-ne* as a contrasting follow-up question later on. In (96), speaker A’s first question is a discourse-initial invitation which we expect to be incompatible with a (cornering) bipolar question meaning. Since there is no contrasting question in the discourse, *-ne* is illicit. However, when the speaker follows up with a second yes-no question about a different topic (boiled fish), *-ne* becomes natural.

(96) Context: A calls B on the phone out of the blue.

A: 你 想不想 今天 晚上 出去 吃 火锅 (??呢)?
Nǐ xiǎng-bù-xiǎng jīntiān wǎnshang chū-qù chī huǒ-guō (??ne)?
you want-not-want today night out-go eat hotpot CT
'Do you want to go out for hotpot tonight (??NE)?'

B: Not really.

A: (那) 你 想不想 吃 水煮鱼 呢?
(Nà) nǐ xiǎng-bù-xiǎng chī SHUǐZHǔ-YÚ ne?
then you want-not-want eat boil-fish CT

'Then do you want to have *boiled fish* NE?' (Constant 2011: 20)

Here, the speaker is simply offering boiled fish as a second option, so the example lacks the cornering effect or quality of "intense inquiry" observed above. In particular, we can see that the question with *-ne* is being interpreted as simple monopolar question, since unambiguously bipolar paraphrases using an alternative question or the addition of *dàodǐ* are unavailable in the same context:

(97) Context: Following the initial question and answer in (96).

a. # (那) 你 想 吃 水煮鱼 还是 不想?
#(Nà) nǐ xiǎng chī shuǐzhǔ-yú **háishi** bù-xiǎng?
then you want eat boil-fish or not-want
'(Then) do you want to have boiled fish or not?'

b. # (那) 你 到底 想不想 吃 水煮鱼?
#(Nà) nǐ **dàodǐ** xiǎng-bù-xiǎng chī shuǐzhǔ-yú?
then you in.the.end want-not-want eat boil-fish
'(Then) do you want to have boiled fish or not?' (elicited)

In fact, the question with *-ne* in (96) can be succinctly paraphrased with the question fragment in (98). This is a good indication that *shuǐzhǔ-yú* 'boiled fish' is a contrastive topic in both questions, and that *-ne* plays the same role in each case.

- (98) (那) 水煮鱼 呢?
 (Nà) shuǐzhǔ-yú **ne**?
 then boil-fish CT
 ‘(Then) how about boiled fish NE?’ (elicited)

Finally, it’s important to observe that (95) and (96) are cases of *narrow* CT, where the contrasting phrases are sub-constituents of the sentence. Indeed, in Chao’s example (95), the stress on the subject is an indication of the narrow focus marking. However per the discussion in section §6.5, we should also expect final *-ne* to occur on sub-questions with broad sentential CT marking. In this case, the contrasting sub-questions will be structurally unrestricted. We do find examples of exactly this kind, as in the following from Chu (2006: 17), due to Shie:⁷⁰

- (99) A: I like watching the stars.
 B: 看 星星, 那 你 会不会 看 星象 呢?
 Kàn xīngxing, nà nǐ huì-bú-huì kàn xīngxiàng **ne**?
 watch star then you can-not-can read astrology CT
 ‘Oh, if you like watching the stars, then do you know astrology NE?’
 (Shie 1991: 149–153)

This question instantiates a category that I will refer to as FOLLOW-UP QUESTIONS. Informally, these are questions that are asked in response to some previous finding. The essential feature of such examples is that the earlier finding provides partial evidence toward resolving the question being asked. To see why follow-up questions lend themselves to CT marking, it is useful to consider cases where English lone CT marks a piece of evidence used as a partial answer:

⁷⁰While the verb in the two clauses is the same (which would ordinarily suggest narrow CT on the object), the sense is different. In one case *kàn* means ‘watch’, while in the other it means something closer to the ‘read’ in ‘reading signs’ or ‘reading palms’.

(100) A: Will they cancel the picnic?

B: Well, [it's going to RAIN]_{CT}...
L+H* L-H%

A: So, given that it's going to rain, will they cancel the picnic??

Here, CT signals that the coming rain is evidence relevant to, but not completely resolving, the question of whether they'll cancel the picnic. In Roberts' (1996) terms, the larger issue of whether they'll cancel the picnic has been broken down into a STRATEGY of two structurally unrelated sub-questions. The first is whether it will rain. The second, residual question is in fact already implied by B's answer, but can be phrased explicitly, as in A's (admittedly pedantic) follow-up question: "Given that it's going to rain, will they cancel the picnic?". This discourse structure is illustrated in the following d-tree:

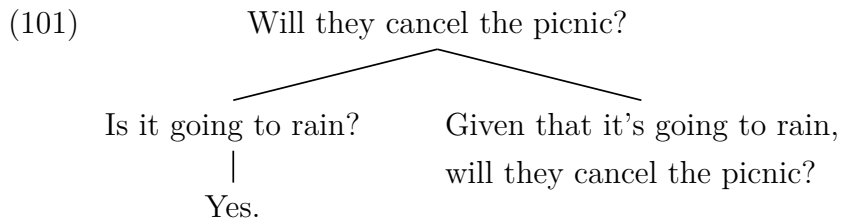

As a sub-question within a strategy, we expect A's follow-up question to support sentential CT. And extrapolating from this example, any question building on preliminary, non-resolving evidence should be construable as a sub-question within a strategy. That is, any question with the form in (102) should license CT marking.

(102) Given that X is true, is Y true?

Follow-up (Yes-No) Question

While English CT prosody doesn't extend to questions (as discussed in section §5.10.2), the distribution of Mandarin *-ne* supports the claims that (i) follow-up questions are CT questions, and that (ii) *-ne* marks CT. In particular, we find that any follow-up question licenses *-ne* (with the exception of particle questions, as predicted on the haplogy account from section §6.6.2). For example:

(103) A: It's going to rain.

B: 那 咱们 是不是 应该 把 野餐 取消 了 呢?

Nà zánmen shì-bú-shì yīnggāi bǎ yěcān qǔxiāo le **ne**?

then we be-not-be should BA picnic cancel ASP CT

'In that case, should we cancel the picnic NE?' (elicited)

Shie's (1991) astrology example from (99) also fits with this analysis. The question about whether you know astrology is a follow-up to an implicit question about whether you like watching stars. Having reached a positive answer to that question, I have some preliminary evidence that you might have additional star-related interests. Thus, the two questions can be understood as making up a strategy addressing an issue that could be paraphrased as "How far does your interest in stars go?". Note also that in both (99) and (103), we find the connective *nà* 'in that case' preceding the question. This is a further indication that the speaker sees the question as working further on an issue where initial progress has already been made.⁷¹

Beyond follow-up A-not-A questions like (99) and (103), we will see in the next section (§6.6.4) that follow-up wh- questions are a robust and frequent licenser of *-ne*. In fact, the general connection between *-ne* and follow-up questions has been noted in the Chinese literature. For example, Li and Thompson (1981: 306) translate *-ne*

⁷¹In the Chinese literature, Shie (1991: 149–153) refers to such uses of *-ne* as conveying "idea development" (Chu 2006: 17).

questions with ‘in that case’, and describe the meaning conveyed as: “In connection with your claim or expectation, let me find out...”. Similarly, Chu (2006: 9) cites Jin (1996) with the claim that *-ne* implies a pre-existing condition or presupposition roughly translatable as *nàme* ‘in that case / if so / then’.⁷²

Questions embedded within the consequent of a conditional provide a mirror image to the case of follow-up questions discussed above. These are known as **CONDITIONAL QUESTIONS** (Isaacs and Rawlins 2008), and are illustrated by the following template:

(104) If X is true, then is Y true? **Conditional (Yes-No) Question**

Again, the facts from English can shed some initial light on how these questions fit into CT discourses. As before, B’s use of CT below indicates an answer to a sub-question:

(105) A: Will they cancel the picnic?

B: [If it RAINS they will]_{CT}...
 L+H* L-H%

A: And will it rain?

Specifically, B is answering an implicit conditional question about whether the picnic will be canceled in the event of rain. However, answering this question doesn’t yet resolve the larger issue, since we don’t yet know the answer to the residual question of whether it actually will rain. In fact, the strategy here is essentially the same as that in (101). The difference is just that the order of the sub-questions has been reversed.

⁷²These descriptions of *-ne*’s contribution are insightful when applied to follow-up questions. However the conditions described are by no means prerequisites for the use of *-ne*. For instance, there is no necessary sense of “in that case” in an example like (95), or in the alternative questions from section §6.6.1.

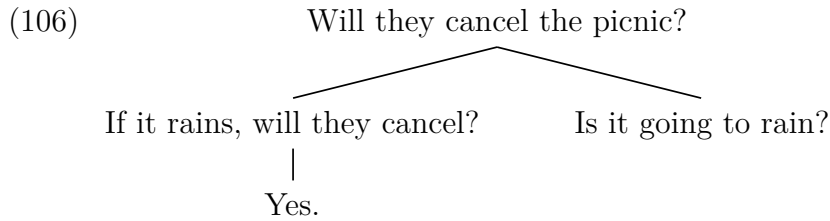

Like follow-up questions, Mandarin conditional questions robustly license *-ne*. The constructed example in (107) and the attested example in (108) illustrate with respect to A-not-A questions in particular:

- (107) 要是 下雨 的话, 咱们 是不是 应该 把 野餐 取消 了 呢?
 Yàoshi xiàyǔ dehuà, zánmen shì-bú-shì yīnggāi bǎ yěcān qǔxiāo le **ne**?
 if rain in.case we be-not-be should BA picnic cancel ASP CT
 ‘If it rains, should we cancel the picnic NE?’ (elicited)

- (108) Context: Thinking to myself about confessing...
- 如果 我 告诉 你 真相, 你 会不会 就 原谅 我 呢?
 Rúguǒ wǒ gàosu nǐ zhēnxiàng, nǐ huì-bú-huì jiù yuánliàng wǒ **ne**?
 if I tell you truth you will-not-will then forgive me CT
 ‘If I told you the truth, would you forgive me NE?’ (web example)

With both follow-up and conditional questions, we’ve seen that an implicit question that’s answered by CT-marked statement in English can be asked explicitly with a CT-marked question in Mandarin. This highlights the general principle that CT statements answer CT questions, as discussed in chapter §3.

As with the other cases where CT marks *sub*-questions, like (95) and (96) above, the follow-up and conditional question uses described above don’t give rise to any cornering effect. For instance, adding the cornering *dàodǐ* ‘in the end’ to Shie’s astrology dialogue, as in (109), is quite unnatural. Thus, the A-not-A questions in (99–108) are being interpreted as monopolar. In these examples, CT is licensed not by virtue of the question itself denoting a strategy, but by virtue of its being one part of a larger strategy.

(109) A: I like watching the stars.

B: ??看 星星, 那 你 到底 会不会 看 星象 呢?
??Kàn xīngxīng, nà nǐ **dàodǐ** huì-bú-huì kàn xīngxiàng ne?
watch star then you in.the.end can-not-can read astrology CT

‘If you like watching the stars, then do you know astrology **or not**?’

(elicited)

In summary, we’ve seen that *-ne* occurs in two types of A-not-A questions—those that denote the sub-questions of a larger strategy, and those that denote a strategy that can be broken into sub-questions. This behavior is expected on a theory of CT like the one presented in chapter §3, where CT simply marks the existence of a discourse strategy of a particular shape, without reference to whether the utterance is answering a sub-question, posing a sub-question, or denoting the entire strategy. Given this analysis, we’ve been able to understand the ability of *-ne* on A-not-A questions to convey a cornering or “intense inquiry” meaning, while also explaining why it does not always do so (when it marks contrasting sub-questions).

6.6.4 wh- Questions

One striking fact about question-final *-ne* is that it overwhelmingly appears in wh-questions, as opposed to other questions forms. For example, the 142 cases of question-final *-ne* in the novel *Rickshaw Boy* break down as 136 wh- questions, 4 alternative questions, and 2 yes-no questions.⁷³

Perhaps as a consequence of this skewed distribution, *-ne* has often been treated in the theoretical literature as a clause-typing particle that marks a clause as a wh-question (Cheng 1991: 21, Li 1992: 139, Aoun and Li 1993: 210, and Cheng et al. 1996: 80). However there are a wealth of arguments against this view (see e.g. Lin 1984: 220–221, Shi 1997: 133–134, Gasde 2004: 315–318, and Li 2006: 13–15), leading most

⁷³Here and throughout I assume that the term “question-final” excludes fragment questions.

authors who treat *-ne* in any detail to reject the analysis.⁷⁴ The simplest arguments that *-ne* is not a wh- question marker are (i) that wh- questions with *-ne* carry extra discourse licensing conditions compared to their counterparts without *-ne*, and that (ii) these conditions are related to the conditions governing the use of *-ne* in *non-wh*- questions, and in statements. In what follows, we will see that these conditions fit with the view that *-ne* marks CT.

If *-ne* is a CT marker, what do we expect its contribution to be in a wh- question? In other question types, we've seen that *-ne* is licensed finally in questions that can be broken up into multiple sub-questions (i.e. those that denote strategies). This explained both its unfailing ability to appear in explicit alternative questions, as well as its constrained appearance in A-not-A questions (restricted to those with bipolar meanings, or that contrast with other sub-questions). Thus, we would expect to find *-ne* in wh- questions that can be construed as a set of sub-questions. This expectation is confirmed in the following example, repeated from above.

(110) (The kids aren't at school. And they're not at home.)

他们 到底 在 哪儿 呢?
 Tāmen dàodǐ zài nǎr **ne**?
 they in.the.end at where CT

'Where (the hell) are they?' (elicited)

Here, the speaker takes a strategy of addressing the issue of the kids' whereabouts by going through places where they might be, one by one. Are they at school? Are they at home? We can understand the wh- question here as encompassing these and other specific possibilities for where the kids might be.⁷⁵

⁷⁴In addition to those mentioned above, the following authors reject the idea that *-ne* is a wh- clause typer or interrogative marker: Hu (1981), Li and Thompson (1981: 306), Shao (1989, 1996: 21), Ye (1994), Shi and Zhang (1995) and Chu (1998, 2006).

⁷⁵One potential alternative would be to say that the wh- question is implicitly restricted to those alternatives that haven't already been resolved. For example, the question could be understood as an

Can any wh- question be decomposed in this way? In theory, yes, but some wh- questions appear to be more prone to decomposition than others. Consider the question in (111), where *-ne* is impossible:⁷⁶

(111) Context: To a stranger, out of the blue...

请问, 现在 几点 了 (#呢)?
 Qǐngwèn, xiànzài jǐ-diǎn le (#ne)?
 excuse.me now how.many-o'clock ASP CT

‘Excuse me, what time is it (#NE)?’ (elicited)

Arguably, the problem with *-ne* in (111) is that asking for the time out of the blue can’t be easily construed as asking which of various times is the correct one. Is it 4:30? Is it 4:31? There is no obvious way the speaker and listener can be understood as having a shared discourse aimed at establishing what time it is step by step, moving towards an answer. Thus, unlike alternative questions, not all wh- questions can (easily) denote strategies.

As predicted on this analysis, (111) improves in a context that really is working piecemeal on the question of the time. In the following attested example, the speaker has established a rough sense of the time by the direction of the sun (ruling out the possibility that it’s morning), but is still looking for a more accurate estimation. In this case, the overarching question of what time it is has already been partly resolved, but a sub-question remains open.

implicit follow-up question: “Given that they’re not in those places, where are they?”. In this case, the restricted wh- question would be a sub-question of the strategy consisting of the unrestricted version. Since I predict CT to be licensed in either case, I will not attempt to distinguish between the two analyses.

⁷⁶In addition to picking a question that resists being broken into yes-no questions, the out-of-the-blue context is critical here in ruling out the construal of this question as a following up on previous evidence. We’ve already seen that follow-up A-not-A questions license *-ne*, and will see that the same is true of wh- questions shortly.

(112) (Gazing at the sun, it was clear to him, the sun was in the west, so it had to be the afternoon.)

可是，现在 到底 几点 了 呢？
 Kěshì, xiànzài dàodǐ jǐ-diǎn le **ne**?
 but now in.the.end how.many-o'clock ASP CT

‘But (exactly) what time was it NE?’ (web example)

As observed in the previous section §6.6.3, *dàodǐ* signals questions that we’ve been working on but haven’t yet reached a satisfactory answer for. Thus, like A-not-A questions, wh- questions with *dàodǐ* appear to always license *-ne*.

In addition to questions that denote strategies, we also expect to find *-ne* on contrasting sub-questions. These examples are in fact quite common, as in (113) below. Here, the implicit question “What about the past?” has been resolved, and the speaker moves on to a contrasting question about the future.

(113) 先 不用 想 过去 的 事 吧，明天 怎样 呢？
 Xiān bú-yòng xiǎng guòqù de shì ba, míngtiān zěnyàng **ne**?
 first not-use think past DE matter PRT tomorrow what.about CT

‘There was no use thinking about what had already passed.

What about tomorrow NE?’ (*Rickshaw Boy*)

Elicited examples provide further evidence that contrasting questions are a licenser for *-ne*. The initial question in (114) is odd with *-ne*, since it neither denotes a strategy nor (yet) functions as a sub-question. However the second wh- question contrasts with the first, and licenses *-ne*. As soon as the second question is uttered, we find ourselves in a strategy of contrasting questions of the form “Who is X?”.

(114) Context: I walk into a store and am confused because it's hard to tell who works for the store and who is a customer. So I ask a stranger...

A: 请问, 谁 是 老板 (#呢)?
Qǐngwèn, shéi shì lǎobǎn (#ne)?
excuse.me who be boss CT
'Excuse me, who is the store owner (#NE)?'

B: The guy over there wearing red.

A: 那 谁 是 员工 呢?
Nà shéi shì yuángōng ne?
then who be worker CT
'Then who are the workers NE?' (elicited)

As is generally the case, to license CT it isn't enough for two questions to contrast by virtue of having a similar structure. Rather, the contrasting questions have to be related under a unified strategy of inquiry. In the following example, my question about who the boss is could conceivably contrast with the salient preceding question of who is in charge of the meat. However since I express that I'm not interested in resolving that question, I remove the possibility that my question about the boss be taken as just one step towards a larger goal that includes resolving your irrelevant question as well.⁷⁷ In the words of one consultant, *-ne* here makes the question sound "too negotiable".

⁷⁷There is a subtle contrast between the earlier example (113) and the present (115). In the earlier case, the question "What about the past?" can be genuinely *answered* by saying that not thinking about it is the best course of action. With (115) however, there is no sense that "I don't care" can stand as a resolving answer to the question of who the meat manager is.

(115) Context: I bought some beef at the store but when I get home I find out it's not fresh. So I go back to the store and talk to a worker there.

A: Hi, I want to report a complaint about this beef.

B: Go talk to Mr. Lin. He's the head of the meat department.

A: 我 不管 谁 负责 肉类。 谁 是 老板 (#呢)?
Wǒ bù-guǎn shéi fùzé ròu-lèi. Shéi shì lǎobǎn (#ne)?
I not-care who in.charge meat-kind who be boss CT

'I don't care who's in charge of meat. Who's the *boss* (#NE)?' (elicited)

In the sub-questions just mentioned, the sense of contrast is immediately clear. The past contrasts with tomorrow, and the boss contrasts with the workers. In these cases, the contrasting questions vary in just one argument position. But as we've seen before, CT can also mark contrasting questions with no structure in common. The remainder of this section will focus on these more elusive cases.

From the examples above, it would appear that *-ne* always marks questions that contrast with an *earlier* question. However this is not always the case. We also find *-ne* marking the first question of a strategy, as in Chu's (2006: 17) example, repeated from section §6.2:

(116) A: "Old K"? How come I didn't know that people call him "Old K"?

B: 你 认识 他 有 多 久 了 呢?
Nǐ rènshi tā yǒu duō jiǔ le ne?
you know he have how long ASP CT

'Well, how long have you known him NE?' (Shie 1991: 149–153)

The effect of B's question is to take a FIRST STEP towards answering A's question. In general, such questions can be paraphrased as follows:

(117) To resolve X, we should start by asking Y.

First Step Question

Question Y is a canonical case of a sub-question. The important point about this structure is that an answer to Y moves us *closer* to answering X, but that no matter how Y is answered, there will still be remaining work to do (i.e. contrasting sub-questions) before X is fully resolved.

As for other types of broadly contrasting sub-questions, *-ne* appears to be possible on any follow-up or conditional wh- question, paralleling the facts with A-not-A questions. In fact, these uses account for a large number of attested examples. For instance, *Rickshaw Boy* includes, among many others, the follow-up questions in (118–119) and the conditional questions in (120–121):

(118) 曹宅 是 不能 再 回去, 上 哪里 去 呢?
Cáo-zhái shì bù-néng zài huí-qù, shàng nǎli qù **ne**?
Cáo-residence be not-can again back-go head.to where go CT
'He couldn't go back to the Cáo family, so where could he go NE?'

(119) Now he had nothing, not even a wife! Sure, she'd been bossy, but...

... 没了 她 怎 能 成 个 家 呢?
... méi-le tā zěn néng chéng gè jiā **ne**?
lack-PFV her how can become CL family CT
'... without her, how would he start a family NE?'

(120) 假若 老 这么 下去, 几时 才 能 买上 车 呢?
 Jiǎruò lǎo zhème xiàqu, jǐ-shí cái néng mǎi-shàng chē **ne**?
 if always this.way go.on what-time only.then can buy-RES cart CT
 ‘If things went on like this, how long would it take to buy the rickshaw NE?’

(121) A: So, I should go, and not worry about them?

B: 你 管 他们, 谁 管 你 呢?
 Nǐ guǎn tāmen, shéi guǎn nǐ **ne**?
 you look.after them who look.after you CT

‘If you worry about them, then who will worry about you NE?’

In (118), the larger issue at hand is where the speaker can go. This has been broken down into two sub-issues, as shown in (122). First, could he go back to the Cáo family? And second, given that he couldn’t go back to the Cáo family, where *could* he go? Similarly, (120) breaks up the issue of how long it will take to buy the rickshaw into two sub-questions, as in (123). One is asked explicitly: “How long would it take to buy it if things went on like this?”. The other is implicit: “Would things actually go on like this?”.

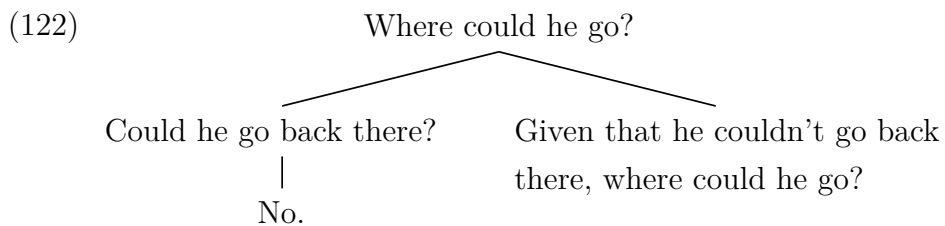

- (123) How long would it take to buy the rickshaw?
-
- How long would it take Would things go on like this?
if things went on like this?

The examples above, and particularly examples (114–115), highlight that whether two questions can be construed as part of a unified strategy is a subtle matter. In fact, if we're right that *-ne* marks CT, then the distribution of *-ne* in questions can provide a valuable diagnostic for sub-question-hood. One case that hasn't been explored in the CT literature is what we can call CLARIFICATION QUESTIONS, as in the following example from Shi (1997):

- (124) A: Why is Lù Dàhǎi still waiting for you here?
- B: 谁 是 陆 大海 (#呢)?
Shéi shì Lù Dàhǎi (#ne)?
who be Lù Dàhǎi CT
'Who's Lù Dàhǎi (#NE)??' (Shi 1997: 134)

Taking the notion of a strategy of questions at an intuitive level, one might assume that resolving the issue of who Lù Dàhǎi is would be a natural first step in a strategy aimed at resolving why he's waiting. Consider for instance a discourse with the following structure:

- (125) Why is Lù Dàhǎi waiting here? (illicit)
-
- Who is Lù Dàhǎi? Did I forget to pay him?
|
He's the tax collector.

However, the infelicity of *-ne* in (124) is evidence that such a structure is not available. Why should this be? The relevant feature of (124) is that B's question doesn't actually address A's question, but rather seeks to clarify the content of the question itself. In

fact, the badness of *-ne* is support for Büring’s (2003) condition on a sub-question being relevant to the immediate question under discussion, which will rule out d-trees like (125).

(126) **Relevance** (Büring 2003: 517–518, 541)

A move *M* is *relevant* iff:

- a. *M* is assertive and $\llbracket M \rrbracket^o$ answers the IQUD⁷⁸, or
- b. *M* is interrogative and at least one answer to $\llbracket M \rrbracket^o$ answers the IQUD.

(127) **Answer** (Büring 2003: 517, 541)

A proposition *p* *answers* a set of propositions *Q* if *p* contextually entails a change in probabilistic weight for at least some $q \in Q$.

Since resolving the question of Lù Dàhǎi’s identity doesn’t change the probability of him being here for one purpose or another,⁷⁹ that question can’t play the role of sub-question that is implied by its position in (125). The infelicity of *-ne* thus serves as a welcome confirmation of one articulated view of what it means to be sub-question within a strategy.

Overall, we’ve seen that while many wh- questions support *-ne*, not all do, and that the dividing line between these two classes is plausibly defined by which questions can be construed as CT questions. The relative ease with which wh- questions (as opposed to yes-no questions) accept *-ne* was argued to derive from the fact that wh- questions (like alternative questions) can usually be decomposed directly into a complex strategy of sub-questions.

⁷⁸The immediate question under discussion (IQUD) is defined as the meaning of the immediately dominating node in the d-tree.

⁷⁹This is a subtle point. If Lù Dàhǎi were a police officer, he’d be more likely to be waiting to arrest me than if he were my friend. However crucially, the properties of the *individual* Lù Dàhǎi aren’t what’s up for debate. The question is simply asking for a reminder of which individual the name picks out. Consider, for instance, that it’s unnatural to elaborate on the question by saying “If Lù Dàhǎi’s a police officer, then he’s here to arrest me.”

6.7 Declarative-Final *-ne*

Declarative-final *-ne* has a remarkably wide range of uses, which on the face of it seem quite different from one another. We begin this section by sorting these various uses into three broad categories of meaning where declarative-final *-ne* is generally supported. We'll see at an intuitive level how these classes of examples are compatible with an understanding of *-ne* as a CT marker. We'll also look at a few environments where a CT marker would be expected to be impossible, and find that declarative-final *-ne* indeed resists these environments. Throughout this section, I'll ignore examples where *-ne* occurs with durative predicates, including (but not limited to) those occurring with overt durative markers like *zhèng* and *zài* and *-zhe*. We'll return to these cases in section §6.8. Since these uses fail diagnostics for CT, they will be argued to involve a separate morpheme *-ne*, which carries an aspectual meaning.

More than other uses of *-ne*, there is a strong tendency for declarative-final *-ne* to appear in sentences containing particular lexical items. These items include the adverbs *hái* 'also/even/still', *cái* 'only then' and *yuánlái* 'actually', the verb *yǐwéi* 'think wrongly', and the durative markers *zhèng*, *zài* and *-zhe*. In the strongest case of co-occurrence, 25% of the 104 uses of declarative-final *-ne* in *Rickshaw Boy* have the adverb *hái* 'also/even/still' in the same sentence. While it may be tempting to analyze *-ne* as “in construction” with these particular items,⁸⁰ we will see that (with the exception of the durative uses) there are core similarities tying these environments together. Specifically, they fit into the three categories loosely defined in (128), and these categories in turn fall under a unified notion of CT.

⁸⁰Cf. Lin's (1984: 224–227) discussion of [*cái* ... *-ne*], [*hái* ... *-ne*], and [*yǐwéi* ... *-ne*] as fixed constructions, and Wu's (2005: 60) classifying *-ne* uses by co-occurring adverb.

- (128) a. not X, rather Y.
 b. not only X, also Y.
 c. at least X, if not Y.

Furthermore, it is the presence of these discourse structures that licenses *-ne*, rather than the mere presence of a particular lexical item. To take just one example, the verb *yǐwéi* ‘think wrongly’ typically licenses *-ne*, as in (129). However, the same combination is bad when presented as a resolving explanation, as in (130). Thus, it is not the verb *yǐwéi* itself licensing *-ne*. Rather, the licenser in (129) is the contrast between mistaken and actual states of affairs—the example fits the template “not X, rather Y”. In (130), the mistaken belief is presented as an explanation. Thus the example doesn’t raise the issue about whether the real state of affairs is one way or another.

- (129) 他 以为 被 骗 了 呢。
 Tā yǐwéi bèi piàn le **ne**.
 he think.wrongly PASS trick ASP CT
 ‘He thought he’d been tricked NE. (But actually...)’
 (elicited)

- (130) A: Why was he angry?
 B: 因为 他 以为 被 骗 了 (??呢)。
 Yīnwèi tā yǐwéi bèi piàn le (??**ne**).
 because he think.wrongly PASS trick ASP CT
 ‘Because he thought he’d been tricked (??NE).’ (elicited)

Overall, these three templates fit into CT discourses with the shapes shown in (131). As we’ve seen with CT marking elsewhere, the complex question and one or more of its sub-questions may be implicit. In (a), there is a strategy directed at resolving which of several options is the correct answer to some salient question, and the speaker reaches the correct answer only after ruling out a contrasting answer. The cases in

(b) and (c) are scalar, involving an implicit issue about the degree that some claim holds. In (b), we first establish that (at least) a relatively low degree X holds, and then go on to say that in fact a higher degree holds as well.⁸¹ The discourse in (c) is similar in that we establish that at least a lower degree X holds. However in this case, the higher degree is either false or remains unknown.

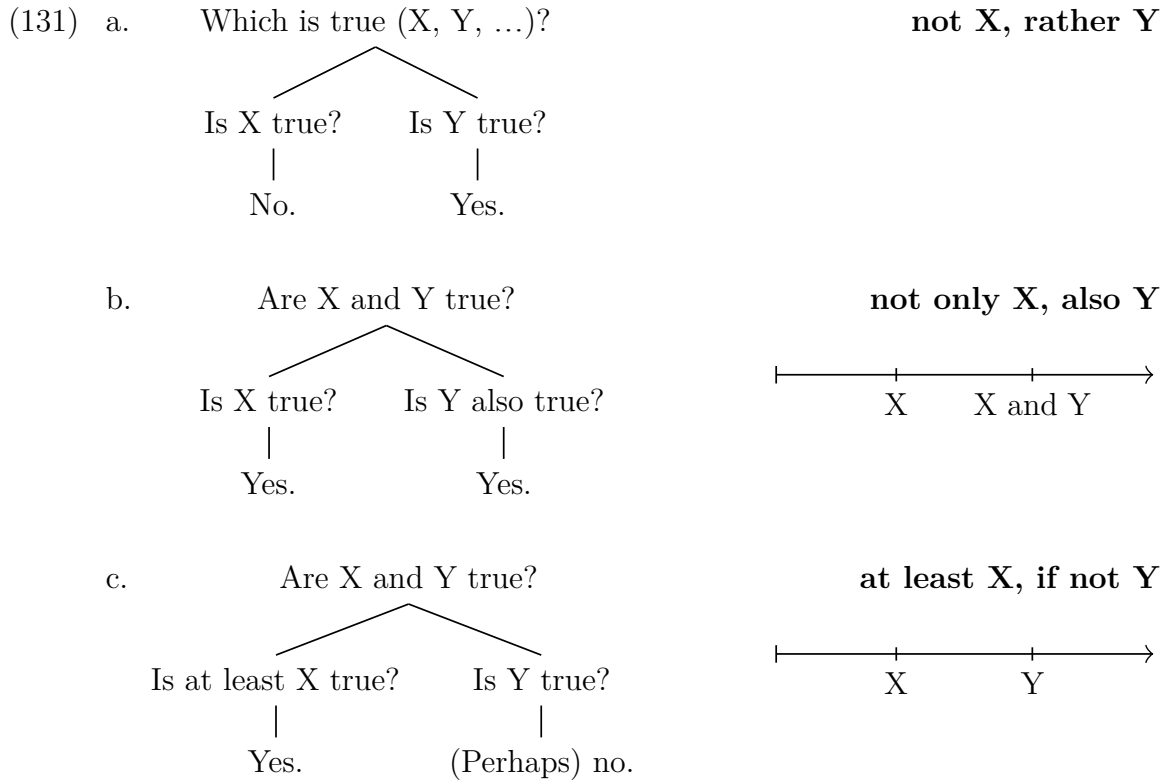

In the following sections, we examine each of these three templates in detail. Given the wide range of examples to be discussed, I begin with the modest goal of showing that individual *-ne*-marked declaratives can be seen as falling under one of the three categories above. In pursuing this goal, I am abstracting away from the issue of how individual examples should be treated in a compositional semantic framework. In fact, for certain examples, it is far from clear how a compositional analysis would be

⁸¹The claim that Y holds could be seen as higher either by virtue of Y being ranked inherently higher than X on some scale, or by virtue of the fact that X and Y together are stronger than X alone (e.g. as evidence in support of some claim).

achieved. I will point these out as we reach them, and we will return to a few specific cases in more detail in chapter §7.

6.7.1 Not X, Rather Y

In the first category of examples, declarative-final *-ne* appears in discourses that arrive at a correct answer after considering one or more incorrect options. I will refer to these examples as fitting the template “not X, rather Y”.

Two examples from *Rickshaw Boy* where this discourse structure is explicit are given in (132) and (133). Note that *-ne* can mark either the clause with *not* as in (132), or the clause with *rather* as in (133). Furthermore, speakers report that each example can have *-ne* on either clause, or on both clauses simultaneously.

(132) Today, he seemed to feel for the first time ...

... 他们 并 不是 穷说, 而是 替他说 呢 ...

... tāmen bìng bú-shì qióng-shuō, ér-shì tì tā shuō **ne** ...

they actually not-be idly-speak rather-be for him speak CT

‘... they weren’t just idly complaining, but rather were speaking for him NE, speaking out the sufferings of him and all fellow rickshaw pullers.’

(133) Context: A newly-wed husband asks his bride...

A: So how much money do you have?

B: Aha! I just knew you’d ask!

你 不是 娶 媳妇 呢, 是 娶 那 点 钱, 对不对?

Nǐ bú-shì qǔ xífù **ne** shì qǔ nèi diǎnr qián, duì-bu-duì?

you not-be marry wife CT be marry that bit money right-not-right

‘You didn’t marry me for a wife NE, you did it for the money, didn’t you!’

Sentences conveying “not X, but rather Y” fit naturally into CT discourse structures. For example, in (133), there is a salient implicit question of why he married her. This question is broken down into two yes/no questions: (i) *Was it for a wife*, and (ii) *Was*

it for the money. In B’s utterance, each clause answers one of these sub-questions, and each clause can be marked with *-ne*.

A minor variation on the “not X, rather Y” template is “not anything else, only Y”. This meaning often occurs with the adverb *cái* ‘only’, conveying that the subject is the only individual satisfying the predicate. For instance, in (134), B conveys that, of the two of them, A is the only one failing to make sense.

(134) A: Are you speaking human language, going around in circles like this?

B: 你 才 不 说 人 话 呢!
 Nǐ cái bù shuō rén-huà **ne!**
 you only.then not speak person-speech CT

‘You’re the one who’s not speaking like a *human* NE!’

(*I Love My Family*, ep. #25)

Another class of examples fitting the “not X, rather Y” template are ones that involve reporting and/or correcting a mistaken belief. One cue for this type of discourse is the verb *yǐwéi* ‘be under the impression’, which is generally used to convey that the belief-holder was mistaken. When the false belief is corrected explicitly, the clause describing the actual state of affairs can be marked with *yuánlái* ‘it turns out / actually’. We see this contrast explicitly in (135), where both clauses end with *-ne*.⁸²

(135) 我 还 以为 是 我的 电脑 中 病毒 了 呢,
 Wǒ hái yǐwéi shì wǒ de diànnǎo zhòng bìngdú le **ne**,
 I even think.wrongly be me POSS computer get virus ASP CT

原来 是 网站 改版 了 呢。
 yuánlái shì wǎngzhàn gǎibǎn le **ne**.
 turn.out be webpage revise ASP CT

‘And I thought that my computer had got a virus NE!’

It turns out it was just that the webpage changed NE.’ (web example)⁸³

⁸²One speaker I consulted found the use of *-ne* in the second clause less natural, commenting that it sounded young, effeminate, and characteristic of the Mandarin spoken in Hong Kong.

More often, either the mistaken belief or the actual state of affairs is left implicit. For instance, in (136), the actual state of affairs is never stated, since it's already clear from the context. The speaker is surprised when her husband suddenly comes in looking gloomy, and for a moment mistakes him for someone else. Implicit here is the contrasting meaning: “Oh, it's not him, rather it's you!”

(136) (Oh! You scared me!)

我	以为	我们	单位	那	精神病	从	医院
Wǒ	yǐwéi	wǒmen	dānwèi	nà	shénjīngbìng	cóng	yīyuàn
I	think.wrongly	our	work.unit	that	psycho	from	hospital
	跑出来	了	呢。				
	pǎo-chū-lái	le	ne.				
	run-out-come	ASP	CT				

‘I thought that psycho from work had escaped from the hospital NE!’

(*I Love My Family*, ep. #114)

Similarly, we have cases where the mistaken belief is left implicit. In (137), even though the speaker didn't necessary hold any specific misconceived notion of how 3D cartoons are made, there is still a sense of contrast conveyed, paraphrasable as “Oh, it's not some other way, it's *this* way!”⁸⁴

⁸³I've minimally altered the example by substituting *wǎngzhàn* ‘web page’ for the original *mǎtóu* ‘dock’, and removing a comma after *yǐwéi* which my consultants judged as unnatural.

⁸⁴This example poses a challenge for compositional analysis. Since the focus marker *shì* seems to mark *zhèi-yàng* ‘this way’ as an exhaustive focus, it's not clear which if any constituent would be analyzed as CT.

(137) Context: The caption for a video clip of Johnny Depp walking like a lizard.

3D 动画片 原来 是 这样 做的 呢!
Sāndī dònghuàpiàn yuánlái shì zhèi-yàng zuò-de **ne!**
3D cartoon turn.out be this-way make-DE CT

‘Oh, so *that’s* how 3D cartoons are made NE!’ (web example)

Like *yuánlái* ‘it turns out’, expressions meaning ‘no wonder’ (e.g. *nánguài*, *yuànbùdé*)⁸⁵ require a discourse that has arrived at a correct answer after considering, or at least searching for, other potential answers. For example, in (138) the speaker comes to understand the true reason for the keyboard being so heavy, and there is an implied contrast between this and other, incorrect explanations.

(138) (After I got the keyboard, I took it apart and was surprised to find that the back side was actually a solid piece of steel.)

怨不得 这么 重 呢!
Yuànbùdé zhème zhòng **ne!**
no.wonder so heavy CT

‘No wonder it was so heavy NE!’ (online product review)

Finally, we find *-ne* in expressions of emphatic contradiction, which again fit the “not X, rather Y” mold of correcting mistaken belief. One colorful way to build contradictions is with the form *gè pì* ‘my ass’, as in (139). Here the issue at hand is the degree to which A understands what B is explaining. B’s retort conveys that rather than understanding a great deal, A in fact barely understands anything at all.

⁸⁵The word *yuànbùdé*, which I’ve glossed as ‘no wonder’, can be decomposed further into the verb *yuàn* ‘blame’ plus the potential complement *bù-dé* ‘not-RES’ (cf. Li and Thompson 1981: 56–58). Thus literally, the expression means something like ‘(one) can’t blame’.

(139) Context: B is explaining a complicated process to A.

A: <interrupting> I understand.

B: 我 还 没 说 完 呢, 你 明 白 个 屁 呢!

Wǒ hái méi shuō-wán ne, nǐ míngbai gè pì ne!

I still have.not speak-finish DUR you understand CL fart CT

‘Understand, my ass! I haven’t even finished explaining!’

Literally: ‘You understand (only) a fart’s worth NE.’ (web example)

While (139) arguably conveys CT meaning in general terms, it’s worth noting this type of idiomatic usage is particularly difficult to analyze within a compositional framework like the one presented in chapter §3. It’s not at all clear which constituent is CT, or what precisely the strategy being referenced consists of. While I won’t pursue this kind of formal account here, I can at least offer the observation that English makes quite similar use of CT, in cases that are equally challenging to formalize. For example, the corresponding English expression *my ass* licenses CT in similar contexts:

(140) Context: Responding to Apple’s slogan “It just works.”

It just works, my ASS... (web example, prosody inferred)

L+H* L-H%

We’ve now seen a range of uses of *-ne* in discourses matching the “not X, rather Y” template. The hypothesis is that these discourses license CT precisely because they break up the task of establishing the correct answer into a series of multiple sub-questions: “Is X the answer? Is Y the answer?”. On this view, it is critical not only that we are considering two contrasting *answers* to the issue at hand, but that the issue is being broken down into two distinct *questions*. This allows us to exclude cases where the negative clause “it’s not X” is logically equivalent to the positive clause “(rather) it’s Y”, as in the following example:

- (141) 不是 活的, 而是 死的 (*呢)!
 Bú-shì huó-de, ér-shì sǐ-de (*ne)!
 not-be alive-DE rather-be dead-DE CT
 ‘It’s not alive, it’s dead (*NE)!’ (elicited)

While the two potential answers ‘alive’ and ‘dead’ clearly contrast, there is no way that “Is it alive?” and “Is it dead?” can stand as contrasting sub-questions, since an answer to either one already implies an answer to the other. Thus, the infelicity of *-ne* in (141) is predicted, since there is no multi-question strategy that would license CT. Data like these make it clear that what licenses *-ne* in the “not X, rather Y” template is not merely the corrective meaning present in (141), but rather the act of reaching an answer in two (or more) steps, the first of which is not fully resolving, and leaves some residual issue.⁸⁶

As expected on the analysis above, simply changing the contrasting adjectives to non-opposites significantly improves the judgment of *-ne*. In (142), the questions “Is it red?” and “Is it green?” can coexist as part of the same strategy, since a (negative) answer to one question doesn’t imply any answer to the other:

- (142) 不是 红色 的, 而是 绿色 的 (?呢)!
 Bú-shì hóngsè de, ér-shì lǜsè de (?ne)!
 not-be red DE rather-be green DE CT
 ‘It’s not red, rather it’s green (?NE)!’ (elicited)

Similarly, if we choose antonyms that are RELATIVE (e.g. *easy/hard*) instead of ABSOLUTE adjectives (e.g. *alive/dead*), the truth of one no longer entails the falsity of

⁸⁶It appears that English *rather* is roughly sensitive to the same requirement as *-ne*, resisting uses like “??It’s not alive, rather it’s dead.” It is for this reason that I include *rather* in the description of the template itself. However I make no specific claim about the licensing of *rather*, and note that the Mandarin connective *ér* which I gloss as ‘rather’ is nevertheless licensed in contexts resisting *-ne*, as in (141).

the other (see Kennedy and McNally 2005: 359), so each can support its own sub-question:⁸⁷

- (143) 不是 很 容易 的, 而是 很 难 的 呢!
Bú-shì hěn róngyì de, ér-shì hěn nán de **ne!**
not-be very easy DE rather-be very hard DE CT
'It's not that easy, in fact it's quite hard NE!' (elicited)

6.7.2 Not Only X, Also Y

A second broad category of examples conforms to the template “not only X, also Y”. Chao (1968: 803) refers to this type of meaning as “interest in additional information”, and treats it as one of the basic seven functions of *-ne*. To start with a case where the contrasting elements are explicit, consider the example in (144) from the sitcom *I Love My Family*. Speaker B conveys that not only has she given A's business cards out to the donut-fryer and the bottle collector, but she has also given one to the fortune teller.

- (144) A: So who did you give my business cards to?
B: I gave one to the guy frying donuts, one to the guy who collects empty bottles, one to the guy who picks up trash...
A: Wait a minute! Can any of them even read??

⁸⁷In light of the above discussion, we may have to rethink the analysis of cornering questions from section §6.6.3. But if the sub-questions of a *ne*-marked question like “Do you love me or not??” aren't just the two alternatives “Do you love me?” and “Do you not love me?”, then what are they? One possibility would be that they denote questions with implicit restrictions, e.g. “Do you (really, if you're telling the truth, for the last time) love me?”, thereby supporting an analysis of the marked question as a sub-question itself.

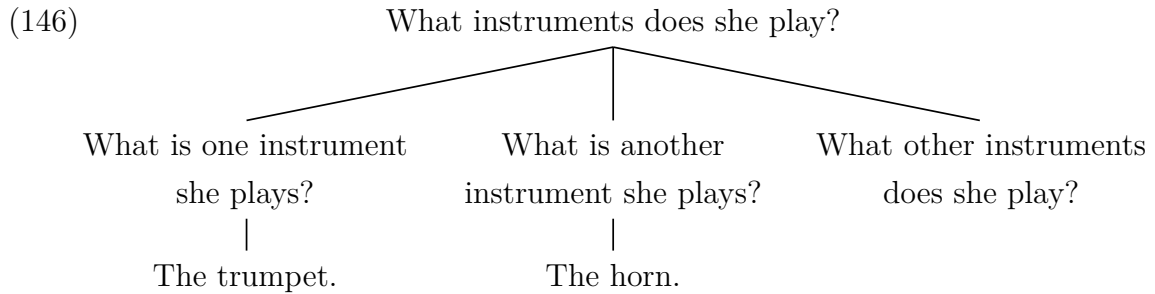

In the fortune teller example in (144), there is no sense of ranking between the contrasting elements (in this case, the recipients of the business cards). However in other cases, the same adverb *hái* takes on a scalar meaning like ‘even’. In (147), the fact that two people hold hands is presented as particularly suggestive evidence that they’re dating—more suggestive than the preceding evidence. Similarly, in (148), the speaker asserts that not only does the somewhat surprising surname Lì exist, but there are even more surprising names like Dà to be found. And in (149) the same type of effect is achieved with *shènzhì* ‘even’.⁹⁰

(147) (I think they’re definitely more than just normal friends. I see them together every day.)

他们 还 手 拉着 手 呢!
 Tāmen hái shǒu lā-zhe shǒu **ne!**
 they even hand hold-DUR hand CT

‘And they even hold hands NE!’ (Li Julie Jiang, p.c.)

⁹⁰This last example comes from Wáng Shuò’s (王朔) novel *The Operators* (顽主).

(148) A: Is there anyone in the world with the surname Lì (丽 ‘Beautiful’)?

B: 有 啊, 丽 算 什么, 还有 姓 大 的 呢。
Yǒu a, Lì suàn shénme, hái-yǒu xìng Dà de **ne**.
have PRT Lì count what even-have surname Dà DE CT

‘Sure, Lì is nothing, there’s even people surnamed Dà (大 ‘Big’) NE!’

(web example)

(149) A: Could you bring one of your books for me to read next time you come?

I’ve never talked face to face with an author before; it’s exciting!

B: 可以。我 甚至 可以 给 你 签 个 名 儿 呢。
Kěyǐ. Wǒ shènzhì kěyǐ gěi nǐ qiān gè míngēr **ne**.
can I even can give you sign CL name CT

‘Sure. I can even give you an autograph NE!’

(Wu 2005: 69)

As we’ve seen with other cases of sentence-final *-ne*, and with CT morphemes more generally, the contrasting elements don’t have to be mentioned explicitly. When *hái* is used to mean ‘even’, it is common for the “not only X” aspect of the meaning to be left implicit. In (150) for instance, the claim that I’ve saved lives is understood as extending the degree to which I can be claimed to have been a do-gooder, but it isn’t clear whether there is any specific piece of evidence that the speaker is contrasting this stronger evidence with.

(150) (When I was young, I was a real do-gooder. I’d treat other people’s problems as my own. But did it do me any good? No!)

我 还 救 过 人 命 呢。
Wǒ hái jiù-guo rén mìng **ne**.
I even save-EXP life CT

‘I’ve even saved people’s lives NE! But was I repaid? No!’ (Rickshaw Boy)

Similarly, Chao's (1968: 803) examples of *-ne* marking "interest in additional information" use *hái* 'even' to draw a scalar contrast, and the "not only X" component of the meaning is left implicit:⁹¹

- (151) a. 他们 还 卖 古琴 呢。
 Tāmen hái mài gǔqín **ne**.
 they even sell zither CT
 'They even sell seven-stringed zithers NE! (among other exotic things)'
- b. 后院儿 还 有 个 金鱼池 呢。
 Hòuyuàn'r hái yǒu gè jīnyú-chí **ne**.
 backyard even have CL goldfish-pond CT
 'And there's even a goldfish pond in the backyard NE!'
- c. 他 还 会 扯谎 呢。
 Tā hái huì chěhuǎng **ne**.
 he even can spin.lies CT
 'He can even spin lies NE! (I didn't expect him to be that clever.)'
- (Chao 1968: 803)

We saw in section §6.3.2 that topic-marking *-ne* regularly marks connectives meaning 'furthermore'. In fact, these accounted for 8% of the uses of topic-marking *-ne* in *Rickshaw Boy*. Since these connectives imply a "not only X, also Y" structure, they also license sentence-final *-ne*, as (152) shows. The fact that 'furthermore' licenses both topic-marking and sentence-final *-ne* is a further indication that we are on the right track in treating the two particles as having a common meaning.

⁹¹At least the contrasting elements are not mentioned in the contexts as Chao describes them.

- (152) (The man looked at the camels Xiángzi was selling, and his heart warmed to them. He knew they were of no real use to him. But just as a book-lover sees a book and has to buy it, someone who's raised camels is the same.)

况且 祥子 说 可以 贱卖 呢。

Kuàngqiě Xiángzi shuō kěyǐ jiàn-mài **ne**.

moreover Xiángzi say can cheap-sell CT

‘And moreover, Xiángzi said he could sell them cheap NE.’ (*Rickshaw Boy*)

In all of the above examples, *-ne* has marked the ‘also’ clause within the structure “not only X, also Y”. While this is certainly the more common case, we also find examples where *-ne* marks the ‘not only’ clause:

- (153) Context: Reviewing a car wash.

不光 能 洗车 呢, 还 能 贴膜、 底盘塑封、 ...

Bù-guāng néng xǐ-chē **ne**, hái néng tiēmó, dǐpán-sùfēng, ...

not-only can wash-car CT also can stick-film chassis-laminate

‘Not only can they wash your car NE, they can also install auto foil, laminate the chassis, renovate the interior, and do maintenance.’ (web example)

Finally, note that the order of the “not only X” and the “also Y” clauses is not relevant to the licensing of *-ne*. For instance:

- (154) Context: Speaker B brings up an inconsistency in a TV show.

A: I just watched the series again and I noticed this too.

B: 是吧 是吧! 不是 光 我 一 个人 发现 的 呢。

Shìba shìba! Bú-shì guāng wǒ yī gè rén fāxiàn de **ne**.

right right not-be only me one CL person discover DE CT

‘Right? Right? So, I’m not the only one to have noticed NE!’

(web example)

6.7.3 At Least X, If Not Y

A third category of declaratives with final *-ne* fits the abstract template “at least X, if not Y”. This template comprises two specific senses, which we can paraphrase as follows:

- (155) a. At least X, and perhaps Y.
b. Although not Y, at least X.

What these structures have in common is that a certain degree (X) on a scale is claimed to hold, and that whether the higher a degree (Y) holds is relevant to the discussion. Let’s start by considering examples of the first type, as in the following:

- (156) Context: Giving advice on growing a medicinal herb in your yard.

至少 两 年 才 能 收 呢，可能 得 三 年。
Zhìshǎo liǎng nián cái néng shōu **ne**, kěnéng děi sān nián.
at.least two year until can collect CT maybe need three year

‘It’ll be at least two years before you can use it NE, maybe three years.’

(web example)

Here, the sense of partial answer-hood that accompanies CT is evident. The speaker is addressing the issue of how long it will take for the plants to reach maturity, and uses a statement with *zhìshǎo* ‘at least’ to provide a partial answer to that question. She commits to the fact that it will take *at least* two years. However this alone doesn’t close the issue of how long it will take. Will it take two? Three? Four? The relevance and openness of this residual issue is made explicit by the speaker’s continuation: “it might take three years”.

Generalizing beyond this example, expressions meaning ‘at least X’ imply that more than X is also a possibility, and thus generally leave a residual issue of whether this greater degree actually holds or not. Geurts and Nouwen (2007) present a formal semantics for *at least* that encodes precisely this generalization. For instance their

semantics for ‘At least three girls snored’ decomposes as two entailments: a factual entailment that there were three snoring girls, and a modal entailment that more than three girls may have snored.

In a similar example, the speaker of (157) below is aiming to convey the degree to which antique mahogany beds are expensive. By using *qǐmǎ* ‘at least’, he implies that the price of a decent one will be no less than six figures, but at the same time—if we follow Geurts and Nouwen’s 2007 proposal—that it could be even higher than that. While this residual question is never stated explicitly, it would be directly relevant to the speaker’s goal of establishing how expensive this type of bed would be. Thus, the sentence is compatible with the partial answer semantics characteristic of CT statements.

(157) (I don’t recommend that you spend money on an antique mahogany bed.)

价钱	贵。	有	点	年	头	又	做	工	精	细	的，
Jiàqian	guì.	Yǒu	diǎnr	niántou	yòu	zuògōng	jīngxì	de,			
price	expensive	have	bit	age	also	work	fine	DE			
		起码	六	位	数	呢。					
		qǐmǎ	liù-wèi	shù	ne.						
		at.least	six-CL	digit	CT						

‘They’re expensive; if you want one that’s a decent age and has careful workmanship, it’ll run you at least six figures NE.’ (web example)⁹²

The connection between ‘at least’ and contrastive topic has also been observed in other languages. For example, in Japanese, the addition of CT *-wa* contributes a sense of ‘at least’ to examples like (158) and (159):⁹³

⁹³While the CT marker in (158) attaches to the phrase ‘25,000 dollars’, this doesn’t imply that the phrase is a topic in the sense of being what the sentence is about. Such non-topical uses of CT are familiar from English (e.g. see section §2.4). With respect to Japanese, they argue against the view *-wa* is interpreted uniformly as a topic marker and that contrastive topics are simply cases of aboutness topics that also contrast. For further discussion of the differences between Japanese contrastive and non-contrastive (or THEMATIC) topics—both of which are *-wa*-marked—see Heycock (2008), Vermeulen (2013), and references therein. Tomioka (2010a) aims for a unified

- (158) A: How much does a new hybrid car cost?
 B: NIMANGOSEN-DORU-**wa** suru.
 25,000-dollar-CT cost
 ‘It costs at least \$25,000...’ (Tomioka 2010a: 120)
- (159) KYOOTO-ni-**wa** iko-o.
 Kyoto-LOC-CT go-EXH
 ‘At least, let’s go to *Kyoto*...’ (Tomioka 2010a: 122)

This last example highlights that while ‘at least’ always has a scalar effect, it is not always apparent which particular scale is being referred to. In examples (156–158), when ‘at least’ was associated with numerals, scales of quantity were most plausible: “if not a higher number, at least a lower number”. However in (159), it is up to interpretation how Kyoto (or perhaps going to Kyoto) is being ranked with respect to other alternatives. For instance, if the options being considered are going (i) nowhere, (ii) to Kyoto, and (iii) to both Kyoto and Tokyo, the speaker could intend that if we can’t go to both cities, we should at least go to one. On the other hand, if the options are going to (i) Tokyo, (ii) Kyoto, and (iii) Sendai, the intention could equally well be that if we can’t go to as big a city as Tokyo, we should at least go to Kyoto (which is bigger than Sendai).

With the possibility of implicit non-numeral alternative scales in mind, we can apply our understanding of ‘at least’ to examples of *-ne* that Chao (1968: 803) describes as conveying an “assertion of equaling degree”:

analysis of both uses, but ends up with a more permissive sense of aboutness, under which sentences like (158) can be about the speech act being performed.

- (160) 有 一百 尺 呢, 深的很 呢。
 Yǒu yī-bǎi chǐ **ne**, shēn-de-hěn **ne**.
 have one-hundred foot CT deep-DE-very CT
 ‘It’s as much as 100 feet deep NE. It’s quite deep NE.’⁹⁴ (Chao 1968: 803)

Here, as in the Japanese examples with *-wa*, there is a sense of ‘at least’, even without any adverbial present. And, as in the Kyoto example (159), there are various possibilities as to what scale is being evoked. One possibility is that the scale simply consists of different depths. In this case, the meaning is paraphrasable as “It’s at least 100 feet deep, and perhaps deeper.” However (160) can equally well be used in a context where the depth is known to be exactly 100 feet, and the speaker just wishes to emphasize that this is an impressive depth. This second meaning is suggested both by Chao’s translation with ‘as much as’, and by the continuation with “It’s quite deep.” In this case, the scale evoked could for instance be one of degrees of how impressive the cave’s depth is. The residual question then would not be whether the cave is in fact deeper than 100 feet, but whether its being 100 feet is impressive enough for the purposes of our conversation (i.e. fully resolves the issue of how impressive it is).

More generally, we can say that in this latter use, *-ne* conveys the meaning that the claim marked is suggestive (non-definitive) evidence in favor of some conclusion that the speaker is trying to reach. In terms of our template, the meaning is “I can at least give you this evidence, if not anything more convincing”.

Partiality, paraphrasable with ‘at least’, is also an essential feature of a further use of *-ne*, in which a piece of evidence is put forward in support of an immediately

⁹⁴Some speakers report that the degree modifier *de-hěn* ‘very’ is characteristic of the older generation’s speech.

preceding claim. Wu (2005: 61) refers to these cases as “claim-support” sequences. The following examples illustrate:⁹⁵

- (161) (Definitely gather evidence of his disloyalty, and find out about his finances. That way, in the event of a divorce, you can fight for some compensation.)

不过 最 好 是 不 要 离 婚 了, 毕 竟 有 三 个 孩 子 呢。
Búguò zuì hǎo shì búyào líhūn le, bìjìng yǒu sān-gè hái zǐ ne.
but most good be do.not divorce ASP after.all have three-CL kid CT

‘Although the best thing would still be not to get divorced.

After all, you do have three kids NE.’ (web example)

- (162) (I was really grateful, but at the time, I was still a little shaken up, so I didn’t think to thank them.)

后 来 妈 妈 说 应 该 把 人 家 的 电 话 留 下,
Hòulái māma shuō yīnggāi bǎ rénjiā de diànhuà liú-xià,
afterward mom say should BA they POSS phone save-RES

再 改 天 去 好 好 谢 谢 人 家, 人 家 救 了 你 呢。
zài gǎi-tiān qù hǎohao xièxiè rénjiā, rénjiā jiù-le nǐ ne.
then change-day go proper thank them they save-PFV you CT

‘Afterward, my mom said “You should have taken down their phone numbers, and gone back to properly thank them on another day. After all, they really saved you NE.”’ (web example)

The key factor licensing *-ne* here is that the supporting evidence is presented as moving the conversation one step closer to the goal of having enough evidence to accept the earlier claim. It is important to recognize that simply asserting something is not always sufficient for closing the issue—or in terms of Stalnakerian models, adding the proposition to the common ground. Indeed, the very fact that a speaker

⁹⁵I’ve avoided Wu’s particular examples since they all involve imperfective situations. This makes it harder to be sure that they contain CT *-ne*, as opposed to the aspectual marker *-ne*. See section §6.8 for further discussion.

brings up evidence in support of a claim betrays their recognition that the claim might not be accepted without some extra work.

This same effect can be called on in retorts like (163), where the claim being insinuated is the *opposite* of the claim the listener has just made. As Wu (2005: 74) observes, the effects of *-ne* and *-le* are different in such retorts. In either case, B is casting doubt on A's claim. However when *-ne* is used, B (in Wu's words) "simply points out" that Xiǎo Wáng's possession of two cars goes against A's claim, thereby *suggesting* that A could be wrong, but leaving the issue open for negotiation. By comparison, final *-le* implies that while he may have been poor before, he isn't any more, thereby closing the issue.

(163) A: Xiǎo Wáng is poor.

B: 他 有 两 辆 车 呢。

Tā yǒu liǎng liàng chē **ne**.

he have two CL car CT

'Well, he has two cars NE... (Is he really poor?)'

B': 他 有 两 辆 车 了。

Tā yǒu liǎng liàng chē **le**.

he have two CL car CT

'He has two cars now LE! (He's not poor.)'

(Wu 2005: 74)

There is a clear parallel between this kind of retort with *-ne* and cases of English retorts with lone CT. Consider Pierrehumbert and Hirschberg's (1990) badminton example:⁹⁶

⁹⁶This is a minor modification of an example discussed by Ward and Hirschberg (1985: 769), originally due to Bing (1979).

(164) A: Alan's such a klutz.

B: He's a good BADMINTON player...

L+H* L-H%

(Pierrehumbert and Hirschberg 1990: 295)

B's implication is that someone who is a good badminton player is unlikely to be a klutz (a clumsy person). However at the same time, the intonation marks the response as non-resolving. In Pierrehumbert and Hirschberg's (1990: 295) words, building on Ward and Hirschberg's (1985) analysis, "B expresses uncertainty about whether being a good badminton player provides relevant information about the degree of clumsiness." This is the same lack of certainty that distinguished the retort with *-ne* from the one without in (163).

So far, we've seen across a range of examples that statements with a meaning "at least X, and perhaps Y" license CT, because they leave open the issue of whether Y holds or not. What about examples of the form "although not Y, at least X"? Here, the issue of Y is already closed, so it is less immediately clear what is left unresolved by 'at least X'. Consider the following example:

(165) Context: Discussing a particular method of parenting...

虽然 不是 大错特错, 至少 不算 个 聪明 的 办法 呢。

Suīrán bú-shì dàcuòtècuò, zhìshǎo bú-suàn gè cōngmíng de bànfǎ **ne**.

though not-be huge.error at.least not-count CL smart DE method CT

'While it's not a grievous mistake, at the very least it's not a smart move NE.'

(web example)⁹⁷

⁹⁷I've modified the example according to elicited judgments of naturalness. The original was:

(i) 虽 不能 说 怎样 大错而特错, 至少 不是 聪明 的 办法 呢。

Suī bù-néng shuō zěnyàng dàcuòértècuò, zhìshǎo bú-shì cōngmíng de bànfǎ **ne**.

although not-can say how huge.error at.least not-be smart DE method CT

'While it's not a grievous mistake, at the very least it's not a smart move NE.'

We can understand the speaker’s goal here as establishing precisely how bad this particular style of parenting is. The speaker addresses the issue in steps. The first clause establishes that it’s not a huge mistake, but this still leaves open a wide range of options for *how* good or bad it is. In the next clause, the use of *zhìshǎo* ‘at least’ implies that the degree of badness meets a certain minimum threshold, and may be higher. Taken together, the speaker has established a maximum and a minimum level of badness, which the degree under discussion lies in between:

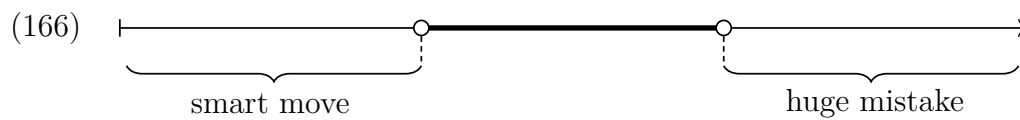

Viewed as a discourse strategy, the speaker has answered two sub-questions that bring us closer to knowing how bad the parenting style is, but still without fully resolving the issue of exactly how bad it is. The following discourse tree illustrates:

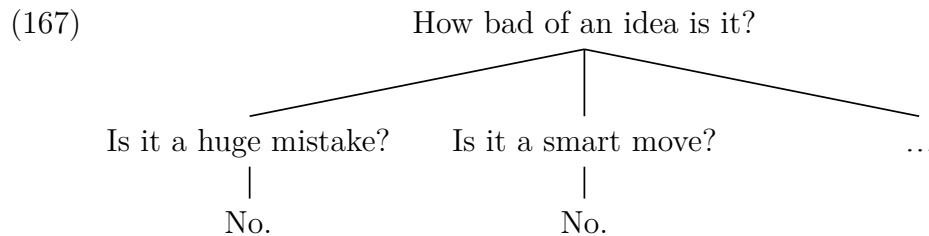

As far as licensing CT is concerned, either the preceding sub-question or the (implicit) following sub-question should be sufficient for CT to be licensed. What matters is just that the sub-question being answered contrasts with other sub-questions, and this is clearly the case. Furthermore, as with preceding templates, we expect CT to be possible on each of the contrasting clauses that answers a sub-question. While not as common, it is possible to have *-ne* on the first clause in the structure “although not X, at least Y”, irrespective of its presence on the second clause:

(168) 虽然 不是 大错特错 呢,
 Suīrán bú-shì dàcuòtècuò **ne**,
 though not-be huge.error CT

至少 不算 个 聪明 的 办法 (呢)。
 zhìshǎo bú-suàn gè cōngmíng de bànfǎ (**ne**).
 at.least not-count CL smart DE method CT

‘While it’s not a grievous mistake NE, at the very least it’s not a smart move.’
 (elicited)

Further examples of “although not X, at least Y” display the same core feature of establishing that a degree falls within a window, by setting an upper bound and a lower bound. Example (169) below is another naturally occurring example, this time from a comedy routine. As before, the two clauses are working together on the goal of locating a specific degree on a single scale. In this case, the issue addressed is how good or bad stealing your own things is.

(169) Context: A story about getting caught trying to steal my bike back after it was stolen from me.

偷 自己的 东西 费点儿劲, 起码 不花 钱 呢,
 Tōu zìjǐ de dōngxi fèi-diǎnr-jìn, qǐmǎ bù-huā qián **ne**,
 steal self POSS thing waste-bit-energy at.least not-spend money CT

买 自己的 东西 又 费劲 还 得 花 钱。
 mǎi zìjǐ de dōngxi yòu fèi-jìn hái děi huā qián.
 buy self POSS thing both waste-energy also need spend money

‘Stealing your own things is a pain, but at least it doesn’t cost anything NE.
 Now *buying* your own things, that’s a waste of both energy *and* money.’
 (web example)

6.7.4 *-ne* Resists Exhaustive Answers

We’ve now seen that a wide range of uses of declarative-final *-ne* can be understood in terms of three specific discourse templates, and that these templates in turn fall under the general rubric of CT discourses. However, to make a convincing argument

that *-ne* marks CT, we should also look at contexts that characteristically resist CT meaning, and check if *-ne* is rejected.

Where exactly CT is predicted to be bad depends on a number of factors specific to individual analyses of CT, as well as our understanding of which constituents in a given example are interpreted as CT and Exh, and what reflexes this has in syntax and prosody. For the most part, I've ignored these particulars in this chapter, since they require focusing on a specific implementation of CT, rather than the general claim that *-ne* is a CT marker. We will come back to address issues for the formal analysis of *-ne* in chapter §7.

Nevertheless, there is at least one environment that categorically resists CT and is easy to characterize without reference to the kinds of details that may vary across implementation. CT resists exhaustive answers to the entire issue at hand. In section §2.4.1 we referred to these as “thoroughly exhaustive” answers. To review a simple case, if the sole issue in the discourse is who destroyed my computer, you can't resolve the issue with a CT utterance:

(170) A: Hey, who smashed my computer?

B: JOHN did.
H* L-L%

B': #JOHN did...
L+H* L-H%

I used the phrase “entire issue at hand” to remind us that CT-marked statements *can* completely resolve the immediate question under discussion, as long as that question is viewed as part of a larger question. For example, the following CT-marked response does resolve the question just asked, but implies other questions about other people:

- (173) a. 我 不知道 她 很 聪明 呢。
 Wǒ bù-zhīdào tā hěn cōngming **ne**.
 I not-know she very smart CT
 ‘I didn’t know she’s smart NE.’
- b. 我 知道 她 很 聪明 (#呢)。
 Wǒ zhīdào tā hěn cōngming (**#ne**).
 I know she very smart CT
 ‘I know she’s smart (#NE).’ (Alleton 1981: 106)

Based on these facts, Alleton (1981: 111) generalizes: “In declaratives, if a cognition verb is used, the speaker suggests [with *-ne*] that the problem being discussed is not solved—at the limit, it could be said that *-ne* takes the place of, or announces a subsequent question.” This description shows a striking similarity to characterizations of CT constructions in other languages.

The contrasts among propositional attitude verbs are fairly clear in out-of-the-blue contexts like the ones Alleton considers. These facts plausibly stem from the generalization that statements of certainty aren’t easily construed as partially resolving any issue, whereas a statement of uncertainty or a guess is easy to understand as leaving an issue open. However, with the right context, we can override this tendency. For instance, the two examples below attest uses of *-ne* with the main verb *zhīdao* ‘know’. Both of these uses fit with a function of *-ne* discussed in the previous

¹⁰⁰Alleton (1981: 104–105) translates this type of example with *-ne* using the past tense, and implies that there is an obligatory contrast of the form “I thought so, but now I no longer do”. While this appears to be the most salient reading in the absence of a context, the sentences do not require it. For instance, we find attested examples like the following:

- (i) Context: Responding to a forum post asking for guesses of a baby’s gender, based on pictures of the mother’s belly.
- 我 猜 是 女孩 呢, 肚脐 内陷 的 是 女孩。
 Wǒ cāi shì nǚhái **ne**, dùqí nèixiàn de shì nǚhái.
 I guess be girl CT navel inward DE be girl
 ‘I guess it’s a girl NE; if your belly button’s an innie it’s usually a girl.’ (web example)

section—see examples (161) and (162). These are Wu’s “claim-support” sequences where a *-ne*-marked statement provides support for an earlier claim.¹⁰¹

- (174) 你 给 那个 丫头 也 发 根 烟, 我 知道 她 抽 烟 呢!
 Nǐ gěi nèi-gè yātou yě fā gēnr yān, wǒ zhīdao tā chōuyān **ne**!
 you give that-CL girl also issue CL cigarette I know she smoke CT
 ‘You can give that girl a cigarette too. I know she smokes NE...’
 (web example)

- (175) Context: My mom expresses minor disapproval over my boyfriend being poor.
 我 知道 我 妈妈 肯定 是 说 着 玩 的,
 Wǒ zhīdao wǒ māma kěndìng shì shuō-zhe wánr de,
 I know my mom surely be speak-DUR play DE
 我 知道 她 肯定 同 意 呢。
 wǒ zhīdao tā kěndìng tóngyì **ne**.
 I know she surely approve CT
 ‘I knew my mom had to be just kidding around.
 I knew she definitely approved (of him) NE.’
 (web example)

To elicit more robust judgments of unacceptability, we can call on the context to ensure that a particular statement is exhaustively resolving. With this technique, we no longer need to restrict our attention to verbs that “automatically” count as resolving or non-resolving. Consider the different functions the sentence “He said he’s going” takes on in (176) and (177). In the first case, the statement clearly provides a partial answer to the question under discussion, and *-ne* is licensed. In the second case, however, the statement is fully resolving. There is no issue in the context (implicit or explicit) left unresolved by the statement. Thus, it is an exhaustive answer, and *-ne* is illicit.

¹⁰¹One consultant from Wulanhaote, Inner Mongolia did not find these attested uses of *-ne* natural. Dialectal variation may be a factor here, although it remains unclear what formal property distinguishes these questionable examples from those that are accepted more broadly.

(176) A: Is Zhāngsān going to the conference?

B: 他 跟 我 说 要 去 呢, (但是 他 还 没 买 机 票。)
Tā gēn wǒ SHUŌ yào qù **ne**... (dànshì tā hái méi mǎi jī-piào.)
he with me say will go CT but he still have.not buy plane-ticket
'He *told* me he's going NE... (but he still hasn't bought a ticket.)'
(elicited)

(177) A: How did you find out that Zhāngsān is going to the conference?

B: 他 跟 我 说 要 去 (#呢)。
Tā gēn wǒ SHUŌ yào qù (**#ne**).
he with me say will go CT
'He *told* me he's going (#NE).'

Similarly, we find that *-ne* is unacceptable on direct answers that pick one choice out of a number of exclusive alternatives:

(178) A: Did you choose the soup or the salad?

B: 我 选 了 汤 (#呢)。
Wǒ xuǎn-le tāng (**#ne**).
I choose-PFV soup CT
'I chose the soup (#NE).'

Finally, *-ne* is generally impossible on direct 'yes' and 'no' answers, which are typically constructed by repeating the main verb:

(179) A: Do you have some time?

B: 有 空儿 (#呢)。	B': 没有 空儿 (#呢)。	
Yǒu kòngr (#ne).	Méi-yǒu kòngr (#ne).	
have time CT	not-have time CT	
'Yeah, I do (#NE).'	'No, I don't (#NE).'	(elicited)

(180) A: Do you like him?

B: 喜欢 (#呢)。	B': 不喜欢 (#呢)。	
Xǐhuan (#ne).	Bù-xǐhuan (#ne).	
like CT	not-like CT	
'Yeah, I do (#NE).'	'No, I don't (#NE).'	(elicited)

One initially puzzling variation on the pattern above arises when we consider perfective predicates, as in (181). While *-ne* is impossible on a positive direct answer, the negative answer with *-ne* is possible. The key to understand this seeming exception is that the negation of the perfective predicate can be viewed as an ongoing situation, and thus licenses the unrelated aspectual morpheme *-ne*. We will return to these cases in the following section.

(181) A: Have you been to Europe?

B: 去过 (#呢)。	B': 没 去过 呢。	
Qù-guo (#ne).	Méi qù-guo ne.	
go-EXP CT	have.not go-EXP DUR	
'Yeah, I have (#NE).'	'No, I (still) haven't NE.'	(elicited)

Overall, as with topic-marking *-ne* and *-ne* in questions, we've seen that the distribution of declarative-final *-ne* is consistent with the view that *-ne* is a general purpose CT morpheme. First, we saw that across a wide range of examples, individual uses of declarative-final *-ne* fit into specific discourse structures, each implying that the *-ne*-marked statement only partially resolves some larger issue. Second, we saw that

declarative-final *-ne* resists a canonical environment that rules out CT—exhaustive answers to the entire question at hand.

6.8 Aspectual *-ne* vs. CT *-ne*

We just saw that declarative-final *-ne* resists exhaustive answers, and this supported the claim that *-ne* is a CT marker. However an immediate challenge to this analysis is posed by examples like the following:

(182) A: Are you carrying the keys?

B: 带着 呢。

Dài-zhe ne.

carry-DUR DUR

‘I’m carrying them NE.’¹⁰²

(elicited)

(183) A: Is he at home?

B: 在 家 呢。

Zài jiā ne.

at home DUR

‘He’s at home NE.’

More loosely: ‘Yeah, he is.’

(elicited)

Speakers report that these are natural as complete dialogues. That is, there is no implication that more is waiting to be said, of the kind reported for examples like (176). To incorporate such data, this section presents the case for distinguishing an aspectual morpheme *-ne* from the CT morpheme discussed in previous sections. We will find that in cases where *-ne* is licensed but doesn’t mark CT, the contribution of *-ne* is aspectual.

¹⁰²I translate the verb *dài* literally as ‘carry’ here and throughout. A more colloquial translation of the exchange would be: “Do you have the keys? Yeah, I do.”

6.8.1 Aspectual *-ne*

From early on, researchers have separated out what are loosely referred to as “continued state” uses of sentence-final *-ne* (Chao 1968, Chu 1978, Marney 1980, Chan 1980, Zhu 1982).¹⁰³ The most detailed treatment of these uses of *-ne* to my knowledge comes from Chan’s (1980) classic analysis of the Mandarin aspectual paradigm, so I focus on her account here. On Chan’s view, sentence-final *-ne* is one of several markers of DURATIVE aspect, entailing the continuation of a process or state through the reference time.

[The durative aspect] is specifically concerned with the internal structure of a process¹⁰⁴ or state, requiring a portion of it to have been actualized prior to the point of interception [...]. The interception point may be the time of speech or some other reference point. (Chan 1980: 42–43)

As markers of durative aspect, *zài*, *-zhe* and *-ne* are similar in that they serve to intercept a situation between (not including) its inception and termination, without focusing on any particular part of the situation’s actualization. (Chan 1980: 61)

Chan’s “point of interception” is just what is more often referred to in Reichenbach’s (1947: 287–298) terms as the REFERENCE TIME. Equivalently, in Klein’s (1994: 3–4) terms, this is the TOPIC TIME, which he defines loosely as “the time for which the claim is made”. Thus, we can restate Chan’s claim within a Reichenbachian schema as follows:¹⁰⁵

¹⁰³The widely adopted term “continued state” (Chao 1968: 802) is misleading from the point of view of Vendler’s (1957) familiar four-way distinction between state, activity, accomplishment and achievement. As we will see shortly, predicates marked by *-ne* are potentially compatible with any durative predicate (state, activity or accomplishment).

¹⁰⁴Chan’s use of the term PROCESS here is consistent with Vendler’s (1957) usage, as encompassing the categories of activity (durative, atelic) and accomplishment (durative, telic).

¹⁰⁵With respect to *-zhe* specifically, this restatement is equivalent to Yang and Bateman’s (2002: §3) claim that *V-zhe* implies that the reference time occurs between the beginning and end of the event. For more specific interpretations of *-zhe*, see Pan (1996: 416) and references therein.

(184) **Durative Aspect**

Durative aspect markers *zài*, *-zhe* and *-ne* require that the reference time be contained within the event time.

Rephrasing the claim in these terms makes it clear that these morphemes all mark imperfective situations. Indeed, it is now generally recognized that *zài* and *-zhe* mark (sub-types of) imperfective aspect (Pan 1996: 416, Smith 1997: 271–276, Yang and Bateman 2002). That aspectual *-ne* also requires imperfectivity is not widely recognized, but is implied by Chan’s characterizations above, as well as by her observation that all three durative morphemes are in direct opposition to the perfective aspect marker *-le*, which marks the termination of a situation (Chan 1980: 39, 71–73).

While their core meaning is shared, the durative morphemes are compatible with different types of predicates, as Figure 6.3 illustrates (Chan 1980: 61–62).¹⁰⁶ The important point for us is that *-ne* can be used across the widest range of durative predicates. Thus, we find *-ne* in combination with *zài* and *-zhe*, as well as by itself, according to the frames in (185).

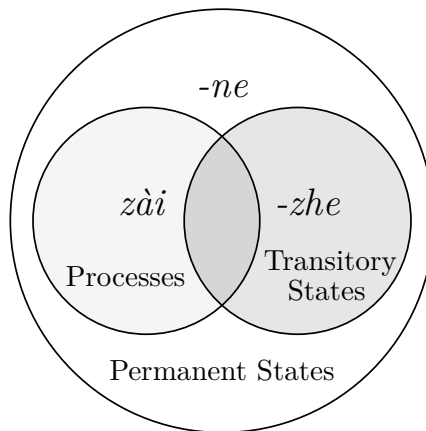

Figure 6.3: Distributions of *-ne*, *zài* and *-zhe*, from Chan (1980: 62)

¹⁰⁶Each morpheme in the figure corresponds to a circle. The descriptive labels mark (non-circular) areas of uniform darkness.

- (185) **Frames for Aspectual -ne** (adapted from Chan 1980: 61)
- a. ... *zài* Verb ... *-ne* (with processes)
- b. ... Verb-*zhe* ... *-ne* (with transitory states)
- c. ... Predicate ... *-ne* (with permanent states)

The examples in (186) and (187) illustrate the first two frames:

- (186) a. 他 在 看 书 呢。
Tā **zài** kànshū **ne**.
he DUR read DUR
'He's reading.'
- b. 他 在 哭 呢。
Tā **zài** kū **ne**.
he DUR cry DUR
'He's crying.'
- c. 他 在 讲 故 事 呢。
Tā **zài** jiǎng gùshi **ne**.
he DUR tell story DUR
'He's telling a story.'
- (Chan 1980: 65)

- (187) a. 她 拿 着 花 呢。
Tā ná-**zhe** huā **ne**.
she hold-DUR flower DUR
'She's holding some flowers.'
- b. 墙 上 挂 着 一 幅 画 呢。
Qiáng-shang guà-**zhe** yī-fú huà **ne**.
wall-LOC hang-DUR one-CL painting DUR
'There's a painting hanging on the wall.'
- c. 李 四 病 着 呢。
Lǐsì bìng-**zhe** **ne**.
Lǐsì sick-DUR DUR
'Lǐsì is sick.'
- (Chan 1980: 65)

When neither *zài* nor *-zhe* is present, *-ne* often occurs with *hái* ‘still’, which is another cue that the predicate is viewed as ongoing. The following examples illustrate these uses:

- (188) a. 她 还 是 学 生 呢。
 Tā **hái** shì xuésheng **ne**.
 she still be student DUR
 ‘She’s still a student.’ ***hái* Predicate ... *-ne***
- b. 书店 离 这 儿 还 很 远 呢。
 Shūdiàn lí zhèr **hái** hěn yuǎn **ne**.
 bookstore from here still very far DUR
 ‘The bookstore is still a long ways from here.’
- c. 天 还 没 亮 呢。
 Tiān **hái** méi liàng **ne**.
 sky still have.not brighten DUR
 ‘The sky still hasn’t gotten bright.’ (Chan 1980: 63)

One more morpheme that frequently co-occurs with aspectual *-ne* is the pre-verbal *zhèng*, which can be translated loosely as ‘just in the middle of’. I gloss it as another durative (DUR) marker in the following example taken from Gasde (2004: 316):

- (189) 别 进 去 ， 他 正 跟 老 秦 说 话 呢。
 Bié jìn-qù, tā zhèng gēn lǎo-Qín shuōhuà **ne**.
 don’t in-go he DUR with old-Qín talk DUR
 ‘Don’t go in, he’s in the middle of talking with Qin.’ (Hou 1998: 441)

As a result of its imperfective meaning, we can derive several predictions for where aspectual *-ne* will be impossible. Chan (1980) discusses the following environments as resisting *-ne*:

- (190) **Restrictions on Aspectual *-ne*** (adapted from Chan 1980: 61)
- a. resists events lacking duration
 - b. resists situations which have terminated
 - c. resists complements denoting the frequency, extent, or duration of an action

By no coincidence, we've already seen some support for these restrictions. In the preceding sections, in order to discover contexts where CT *-ne* was bad (i.e. exhaustive answers, etc.), it was necessary to first control by picking situations that rule out aspectual *-ne*. For instance, in (191), repeated from above, perfective *-le* implies that the choice is already complete, so the situation described is incompatible with the imperfective meaning of aspectual *-ne*.

(191) A: Did you choose the soup or the salad?

B: 我 选了 汤 (#呢)。
 Wǒ xuǎn-le tāng (#ne).
 I choose-PFV soup DUR
 'I chose the soup (#NE).' (elicited)

Similarly, in the following example, also repeated from above, the experiential aspect marked by *-guo* is incompatible with aspectual *-ne*, which follows from analyses of *-guo* as conveying a sub-type of perfective aspect (see e.g. Smith 1997: 266–271):

(192) A: Have you been to Europe?

B: 去过 (#呢)。
 Qù-guo (#ne).
 go-EXP DUR
 'Yeah, I have (#NE).' (elicited)

The analysis of *-ne* as conveying durative aspect is crucial for explaining the contrast between the felicitous examples from (186–189) and the infelicitous ones in (191–192). Furthermore, as we will see shortly, this analysis lets us make sense of the appearance

of *-ne* across a wide range of contexts where CT would not be licensed. However before turning to this evidence, let me address a few criticisms that have been leveled against the claim that *-ne* can convey an aspectual meaning.

The publication of Li and Thompson's (1981) influential *Mandarin Chinese: A Reference Grammar* marked the beginning of a long line of rejections of Chan's and other aspectual analyses of *-ne*. Li and Thompson (1981), Lin (1984), Chu (1998, 2006), Wu (2005), Li (2006) and others all attempt either overtly or covertly to collapse these aspectual uses with other sentence-final uses (or all uses, in the cases of Lin 1984 and Chu 2006).¹⁰⁷ There are two main arguments that have been put forward in favor of this collapse; however we will see that neither argument is convincing.

The first and most common objection to the idea that *-ne* is an aspectual particle is summed up by Li and Thompson's (1981: 302) statement about (193): "The continued-state meaning of [this example] is conveyed [...] not by *-ne*, but by the durative aspect marker *-zhe*."

- (193) 张三 说着 话 呢。
 Zhāngsān shuō-**zhe** huà **ne**.
 Zhāngsān speak-DUR speech DUR
 'Zhāngsān is speaking (to someone).' (Li and Thompson 1981: 302)

Indeed, in nearly all of the examples we've considered up until now, what I've referred to as aspectual *-ne* has co-occurred with another morpheme that contributes a durative meaning. Lin (1984: 226) raises the same objection with respect to the following example repeated from above, saying that in this case it's the adverb *háí* 'still', rather than *-ne* that expresses continuation.

¹⁰⁷Beyond those mentioned above, Li (2006: 9) cites Hu (1981), Chu (1984, 1985a, 1985b), King (1986) and Shao (1989) as all advocating that there is only one *-ne*. On the other side, authors who advocate an aspectual meaning for *-ne* include Chao (1968), Chu (1978), Marney (1980), Chan (1980) and Zhu (1982). Recent accounts adopting the traditional aspectual analyses include those of Hagstrom et al. (2001: 84) and Gasde (2004: 316).

- (194) 她 还 是 学 生 呢。
 Tā **hái** shì xuésheng **ne**.
 she still be student DUR
 ‘She’s still a student.’ (Chan 1980: 63)

This is not a strong argument, and we can counter it from several different angles. To begin with, even if it were true that aspectual *-ne* were restricted to sentences containing other aspectual morphemes, this wouldn’t imply that *-ne* itself isn’t aspectual. The argument takes on a troubling assumption about redundancy in language—the assumption that if one morpheme carries a certain meaning, other morphemes in the same sentence must be conveying something else. Logically, there is no reason why, for instance, *-zhe* and *-ne* couldn’t both have aspectual meanings, and work together redundantly, perhaps even through an agreement or concord process.

Moreover, in addition to examples like those above, we also find aspectual *-ne* in sentences with no supporting aspectual morphology. The example in (195) from Gasde (2004: 316) is one such case. Note further that this statement can serve as an exhaustive response, for instance as an answer to the question “Is it raining?”. Thus, we can be confident that this is not CT *-ne*. What licenses *-ne* here is just that the raining situation described is viewed as ongoing with respect to the time of speech.

- (195) 下 雨 呢。
 Xià-yǔ **ne**.
 fall-rain DUR
 ‘It’s raining.’ (Zhu 1982: 209)

The second objection raised against the aspectual analysis is that contrary to Chan’s (1980: 39, 62, 71–73) claim, *-ne* can co-occur with the perfective and inchoative parti-

cles *-le* (Lin 1984: 229). This is entirely unexpected if *-ne* is uniformly interpreted as a durative marker with an imperfective meaning. The following examples illustrate:¹⁰⁸

(196) Context: Answering a question of what school my daughter Wéiwei attends.

瑋瑋 都 进了 高中 了 呢! 老太婆 啰!
 Wéiwei dōu jìn-le gāozhōng le **ne!** Lǎotàipó luo!
 Wéiwei even enter-PFV high.school ASP CT old.woman PRT

‘Wéiwei is already in high school NE! I’m an old woman!’ (Lin 1984: 229)

(197) 我 还 给了 算命 的 孙总 一 张 呢。
 Wǒ hái gěi-le suànmìng de Sūn-zǒng yī zhāng **ne.**
 I also give-PFV tell.fortune DE Sūn-mister one CL CT

‘I *also* gave one to Mr. Sūn the fortune teller NE.’

(*I Love My Family*, ep. #7)

This is a solid argument against the view that *-ne* always conveys durative aspect.¹⁰⁹ However these examples are not a problem for the present view that *-ne* is ambiguous between aspectual and CT meanings. In fact, both examples fall in with our understanding of *-ne* as a CT marker. We already saw in section §6.7.2 that (197) is answering an implicit sub-question “Who *else* did you give one to?”. Lin’s example in (196) is more subtle, but is plausibly using the fact that Wéiwei is already in high school as support for a larger claim that a lot of time has passed, and I’m now old. Thus, we can understand the speaker as treating the question about where Wéiwei is in school as a sub-issue of a larger question about the degree to which time has passed and I’ve aged.

¹⁰⁸The first example comes from the Yú Líhuá’s (于梨华) novel *The True Nature of the Conference* (会场现形记). The second is repeated from (144) above, where the complete context can be found.

¹⁰⁹It is not clear whether any of the promoters of aspectual *-ne* are committed to this narrow view. For instance, while Chan (1980) doesn’t discuss other uses, she also never commits to the aspectual meaning being the *only* meaning available to *-ne*.

In the remainder of this section, we look at four specific environments that provide additional support for there being separate particles $-ne_{\text{ASP}}$ and $-ne_{\text{CT}}$. Specifically, we will see that $-ne$ can occur in a range of contexts that resist CT, but only when the situation describe is viewed as ongoing.

6.8.2 $-ne_{\text{ASP}}$ Occurs in Exhaustive Answers

As we've already seen, exhaustive answers typically resist $-ne$, as expected if $-ne$ marks CT. The following examples repeated from above illustrate:

(198) A: How did you find out that Zhāngsān is going to the conference?

B: 他 跟 我 说 要 去 (#呢)。

Tā gēn wǒ SHUŌ yào qù (#ne).

he with me say will go CT

'He *told* me he's going (#NE).'

(elicited)

(199) A: Did you choose the soup or the salad?

B: 我 选了 汤 (#呢)。

Wǒ xuǎn-le tāng (#ne).

I choose-PFV soup DUR

'I chose the soup (#NE).'

(elicited)

Notice that in each of these examples, the direct answer describes a situation that is *not* being viewed as ongoing. This is particularly clear in these cases, given that the events described are instantaneous. However, importantly, even situations that hold over a period of time can fail to support durative interpretations, and thereby fail to license $-ne$. Consider the following examples:

(200) A: Do you have some time?

B: 有 空儿 (#呢)。	B': 没有 空儿 (#呢)。	
Yǒu kònggr (#ne).	Méi-yǒu kònggr (#ne).	
have time CT	not-have time CT	
'Yeah, I do (#NE).'	'No, I don't (#NE).'	(elicited)

(201) A: Do you like him?

B: 喜欢 (#呢)。	B': 不喜欢 (#呢)。	
Xǐhuan (#ne).	Bù-xǐhuan (#ne).	
like CT	not-like CT	
'Yeah, I do (#NE).'	'No, I don't (#NE).'	(elicited)

While 'having free time' and 'liking him' describe states that persist over time, they are not being viewed as situations that continue through the reference time (in this case, the speech time). For example, without the addition of an adverb like *háí* 'still', (201) is understood as addressing speaker B's general or current state of mind, rather than whether or not there has been a continual state of liking.¹¹⁰

In contrast to the examples above, *-ne* is licensed on exhaustive answers when the predicate describes a situation that *is* viewed as ongoing. Consider the pair in (202). In the positive answer, the situation of carrying the keys is viewed as ongoing, as confirmed by the presence of the post-verbal durative marker *-zhe*, and *-ne* is licensed. In the negative answer, the predicate describing not having the keys is incompatible with durative aspect, and *-ne* is illicit.¹¹¹

¹¹⁰In eliciting judgments on (200) and (201), the lead-up questions were introduced in Mandarin using a simple particle question built on the same predicate as the response, for example as in (i). The same approach was used for similar upcoming examples in this section.

(i) 你 喜欢 他 吗?
Nǐ xǐhuan tā ma?
you like him Y/N
'Do you like him?'

¹¹¹Why this predicate can't be viewed as ongoing is an interesting question that I will not resolve here. I do not wish to argue that 'not carrying' is fundamentally any less easily viewed as ongoing

(202) A: Are you carrying the keys?

B: 带着	呢。	B': 没	带	(#呢)。	
Dài-zhe	ne .	Méi	dài	(#ne).	
carry-DUR	DUR	have.not	carry	DUR	
'I'm carrying them NE.'		'I'm not carrying them (#NE).'			(elicited)

Similarly the predicate *zài jiā* 'be at home' supports a durative interpretation, while the negative form *bú-zài jiā* 'not be at home' doesn't:¹¹²

(203) A: Is he at home?

B: 在 家	呢。	B': 不在	家	(#呢)。	
Zài jiā	ne .	Bú-zài jiā	(#ne).		
at home	DUR	not-at home	DUR		
'He's at home NE.'		'He's not at home (#NE).'			(elicited)

The responses that license *-ne* above share the property of confirming the proposition suggested by the preceding question. However we can demonstrate that the bias of the question is not a relevant factor. For example, if we change the lead-up question in (203) to its negated form, as in (204), the judgments for the answers remain the same. What matters is just the polarity of the response (which is tied to the availability of durative aspect).

than 'carrying'. Thus, we should look to ground the impossibility of durative aspect here in terms of the linguistic structure. For example, it may be that the particular form of negation *méi* 'did not' only permits a reading referring to a particular time (or interval) when the speaker failed to take the keys, along the lines of the English "I didn't turn off the stove" (Partee 1973: 602).

¹¹²Again, this reflects facts about how these particular Mandarin predicates can be used, rather than facts about the concepts of being at home vs. being away from home. The ability of the positive form of the locative verb *zài* to license durative aspect may in fact need to be treated as a special case, following Chan (1980), since it's the historical source of the preverbal durative aspectual morpheme *zài*.

(204) A: 他 不在 家 吗?
 Tā bú-zài jiā ma?
 he not-at home Y/N
 ‘He’s not at home?’

B: 在 家 呢。 B’: 不在 家 (#呢)。
 ZÀI jiā **ne**. Bú-zài jiā (**#ne**).
 at home DUR not-at home DUR
 ‘No, he *is* at home NE.’ ‘Yeah, he’s not at home (#NE).’ (elicited)

Predicates marked with the perfective morphemes *-le* and *-guo* provide further confirmation that durative aspect is what licenses *-ne*. These predicates show the reverse behavior of the durative predicates discussed above. Specifically, the negated predicate licenses *-ne*, while the positive predicate resists *-ne*:

(205) A: Have you been to Europe?

B: 去过 (#呢)。
 Qù-guo (**#ne**).
 go-EXP CT
 ‘Yeah, I have (#NE).’

B’: 没 去过 呢。
 Méi qù-guo **ne**.
 have.not go-EXP DUR
 ‘No, I (still) haven’t NE.’ (elicited)

(206) A: Has she arrived yet?

B: 到了 (#呢)。
 Dào-le (**#ne**).
 arrive-PFV DUR
 ‘She’s arrived (#NE).’

B’: 还 没 到 呢。
 Hái méi dào **ne**.
 still have.not arrive DUR
 ‘She still hasn’t arrived NE.’ (elicited)

Since perfective predicates describe completed situations, they are inherently incompatible with being viewed as ongoing. However when the verb is negated as in the B’ examples, the situation described is an ongoing state of not having reached the point of culmination, and so durative aspect *-ne* is licensed.

Taken together, the collection of examples above shows that neither the polarity of the question, nor the polarity of the answer correlates with the availability of *-ne*.

Rather, in exhaustive answers, *-ne* is licensed if and only if the predicate is compatible with durative aspect.

6.8.3 *-ne*_{ASP} Occurs in *because*-Clauses

In section §6.3.6 we saw that *-ne* regularly appears marking *if*-clauses, but strongly resists marks *because*-clauses. The following elicited pair, repeated from above, illustrates the contrast:

- (207) 我们 本来 以为 他 够 资格, 可是 ...
 Wǒmen běnlái yǐwéi tā gòu zīgé, kěshì ...
 we originally think.wrongly he enough qualified but
 ‘We had originally assumed he was qualified, but ...’
- a. ... 要是 他 实际上 不 合格 呢, 我们 不能 雇 他。
 ... yàoshi tā shíjìshang bù hégé ne, wǒmen bù-néng gù tā.
 if he actually not qualified CT we not-can hire him
 ‘... if he actually isn’t qualified NE, we can’t hire him.’
- b. ... 因为 他 实际上 不 合格 (#呢), 我们 不能 雇 他。
 ... yīnwèi tā shíjìshang bù hégé (#ne), wǒmen bù-néng gù tā.
 since he actually not qualified CT we not-can hire him
 ‘... since he actually isn’t qualified (#NE), we can’t hire him.’

We understood this distribution in terms of the fact that *if*-clauses can function as contrastive topics, while *because*-clauses can’t. However we already saw one attested exception to this generalization from the novel *Rickshaw Boy*:

(208) It was one day, when I was carrying a lamp. I still remember it clearly ...

... 因为 我 同着 两三 个 娘们
... yīnwèi wǒ tóng-zhe liǎng-sān gè niáng-men
because I with-DUR two-three CL woman-PL

正 在 门口 坐着 呢。
zhèng zài ménkǒu zuò-zhe **ne**.
DUR at doorway sit-DUR DUR

‘... because I was with a few women sitting in the doorway NE.’

(*Rickshaw Boy*)

We are now in a better position to understand this case, not as an exceptional use of CT, but rather as an unexceptional use of aspectual *-ne*. The co-occurring aspectual morphemes *zhèng* and *-zhe* are cues to the durative viewpoint of the sitting situation. Given that this is aspectual *-ne*, we can hold onto the claim that CT *-ne* uniformly resists marking *because*-clauses.

To show that durative aspect is the crucial factor licensing *-ne* in *because*-clauses, we can turn to minimal pairs like (209). With the ongoing situation of being busy in (a), *-ne* is licensed. In (b) however, the event of becoming awake is already completed, and so *-ne* is impossible.

(209) a. 因为 老师 正 忙着 呢, 所以 不应该 打扰 她。
Yīnwèi lǎoshī zhèng máng-zhe **ne**, suǒyǐ bù-yīnggāi dǎrǎo tā.
since teacher DUR busy-DUR DUR so not-should disturb her

‘Since the teacher is busy doing something NE, you shouldn’t disturb her.’

b. 因为 老师 刚 睡醒 了 (*呢), 所以 不应该 打扰 她。
Yīnwèi lǎoshī gāng shuìxǐng le (***ne**), suǒyǐ bù-yīnggāi dǎrǎo tā.
since teacher just wake.up ASP DUR so not-should disturb her

‘Since the teacher just woke up (*NE), you shouldn’t disturb her.’

(elicited)

6.8.4 $-ne_{\text{ASP}}$ is Lower than $-ne_{\text{CT}}$

While aspectual $-ne$ and CT $-ne$ never co-occur (due to a haplology constraint to be discussed in section §6.8.6), we can make inferences about their syntactic positions based on their linear order relative to other material in the sentence-final domain. This will lead to the conclusion that like other aspectual particles, $-ne_{\text{ASP}}$ occupies a lower position than $-ne_{\text{CT}}$.

As Li (2006) shows, sentence-final particles across the Chinese family stack up in predictable orders. If we follow Li in associating the sentence-final particles with operator positions in the left periphery (in the sense of Rizzi 1997), the generalization that emerges is that material higher in the periphery surfaces further rightward in the Chinese sentence-final domain. As one example, the sentence-final (inchoative) aspectual particle $-le$ always surfaces before the yes-no question particle $-ma$, which is argued by Li (2006: 171) to occupy a higher structural position:¹¹³

- (210) 下雨 了 吗?
Xià-yǔ le ma?
fall-rain ASP Y/N
'Is it starting to rain?' (Zhu 1982: 207–214, via Li 2006: 6)

Turning to the two particles $-ne$, we can tease apart their positions by observing their behavior in questions formed with the final tag-like expression $méi-yǒu$ 'not-have'.¹¹⁴ These questions are sometimes referred to as NEGATIVE PARTICLE questions, although

¹¹³In Li's (2006) system, sentence-final $-le$ is treated as a tense marker, while $-ma$ is treated as a degree particle (see Li 2006: §2.3).

¹¹⁴As Cheng et al. (1996: 67) observe, the negation marker $méi-yǒu$ is restricted to clauses with particular aspectual features; in other cases, the negative element $bù$ is used instead. See also Hagstrom (2006: 178, 205), who cites Ernst (1995) and Lin (2003) for further discussion of these facts. I focus on questions formed with $méi-yǒu$ here, since they are compatible with durative aspect.

the formal status of *méi-yǒu* as being like or unlike other sentence-final particles is debated.¹¹⁵ The following case from Cheng et al. (1996) exemplifies the class:

- (211) 胡斐 看完了 那 本 书 没有?
Húfěi kàn-wán-le nèi běn shū **méi-yǒu**?
Húfěi read-finish-PFV that CL book not-have
'Has Húfěi finished reading that book?' (Cheng et al. 1996: 65)

Cheng et al. (1996) suggest that *-ne* is incompatible with *méi-yǒu* questions, judging the occurrence of *-ne* in (212) as ungrammatical. However many authors report that this sentence and others like it are acceptable. For example, Li's (2006: 146) consultants accept the use of *-ne* in (212), and Hagstrom (2006: 203) cites both Zhang (1997) and Hsieh (2001) as indicating that questions like those in (213) and (214) are acceptable.

- (212) 他 有 钱 没有 呢?
Tā yǒu qián méi-yǒu **ne**?
he have money not-have CT
'Did he have money (or not) NE?' (Cheng et al. 1996: 80, Li 2006: 146)

Conflicting Judgments

- (213) 你 给了 他 钱 没有 呢?
Nǐ gěi-le tā qián méi-yǒu **ne**?
you give-PFV him money not-have CT
'Did you give him money (or not) NE?' (Hagstrom 2006: 203)

¹¹⁵See Cheng et al. (1996), Hagstrom (2006: §6) and Li (2006: §5).

- (214) 他 吃了 饭 没有 呢?
 Tā chī-le fàn méi-yǒu **ne**?
 he eat-PFV food not-have CT
 ‘Did he eat (or not) NE?’ (Hagstrom 2006: 203)

If these uses of *-ne* mark CT—which they must, since the situations described are not viewed as ongoing, so aspectual *-ne* wouldn’t be licensed—then we have an explanation for the lack of clarity in the judgments. Following the discussion in section §6.6.3, these questions are predicted to license CT *-ne* only if they are interpreted as either contrasting sub-questions, or else as cornering alternative questions. In fact, the judgments become clearer if we reinforce the sense of cornering by adding the adverb *dàodǐ*, as discussed in section §6.6.3. For instance, the speakers I consulted accepted the following attested example without hesitation:

- (215) 我 现在 到底 怀孕 了 没有 呢?
 Wǒ xiànzài dàodǐ huáiyùn le méi-yǒu **ne**?
 I now in.the.end pregnant ASP not-have CT
 ‘Am I pregnant or not NE?’ (web example)

Similarly, we find attested examples of *-ne* following *méi-yǒu* on contrasting sub-questions, as in (216). Note that in both (215) and (216), markers of perfectivity (*-le* and *-guo*) rule out the possibility that *-ne* is conveying durative aspect.

- (216) (My friends have been there on a work trip.)
 你 去过 没有 呢?
 Nǐ qù-guo méi-yǒu **ne**?
 you go-EXP not-have CT
 ‘Have *you* been NE?’ (web example)

Compared with the CT particle, the aspectual particle *-ne* appears to be quite restricted in *méi-yǒu* questions. However, crucially, when the combination does occur, the position of *-ne* is always before *méi-yǒu*. Both the attested example in (217) and

the elicited example in (218) were accepted by most (but not all) of the speakers I consulted:

- (217) 大家 的 QQ 还 上着 呢 没有?
Dàjia de QQ hái shàng-zhe **ne** méi-yǒu?
everyone POSS QQ still online-DUR DUR not-have
'Is everyone's QQ still online NE? I can't connect.'¹¹⁶ (web example)

- (218) 钥匙 带着 呢 没有?
Yàoshi dài-zhe **ne** méi-yǒu?
key carry-DUR DUR not-have
'Do you have the keys NE?' (elicited)

From the discussion above, the generalization emerges that in *méi-yǒu* questions, CT *-ne* comes after *méi-yǒu*, while aspectual *-ne* comes before it. The following negative data confirm this pattern. In example (219), aspectual *-ne* is ruled out by the presence of experiential *-guo*, so only CT *-ne* is possible. We find that CT *-ne* is illicit before *méi-yǒu*, regardless of the presence or absence of *-ne* afterward. Conversely, example (220) rules out CT *-ne* by means of a context that doesn't support treating the question as a sub-question or strategy. Thus only aspectual *-ne* is licensed, and we find that its position is necessarily before *méi-yǒu*.

¹¹⁶QQ is a popular instant messaging service in China.

(219) (Zhāngsān has been to Japan.)

你 去过 (*呢) 没有 (呢)?
Nǐ qù-guo (*ne) méi-yǒu (ne)?
you go-EXP DUR not-have CT

‘Have *you* been there?’ (elicited)

(220) Context: As we leave the house, I ask you out of the blue...

钥匙 带着 呢 没有 (#呢)?
Yàoshi dài-zhe ne méi-yǒu (#ne)?
key carry-DUR DUR not-have CT

‘Do you have the keys NE?’ (elicited)

Overall, it is easy to account for these ordering facts if we distinguish *-ne*_{ASP} and *-ne*_{CT} as two separate morphemes. In fact, the positioning of aspectual *-ne* in the clause-final domain falls in with the class of clause-final aspectual particles more generally. Specifically, Hagstrom (2006: 206) observes that the inchoative aspectual particle *-le* (which is typically clause-final) always occurs before *méi-yǒu* in negative particle questions, as shown in (221). This is an indication that the ordering of aspectual *-ne* relative to *méi-yǒu* is not idiosyncratic. Rather, aspectual final particles pattern as a class in preceding *méi-yǒu*.

(221) 他 吃饭 (了) 没有 (*了)?
Tā chī-fàn (le) méi-yǒu (*le)?
he eat-food ASP not-have ASP

‘Has he eaten?’ (elicited, cf. Hagstrom 2006: 206)

One remaining question for the account presented here is why we don’t find examples of the two particles *-ne* in the same sentence. For example, the following examples are judged as degraded by most speakers:¹¹⁷

¹¹⁷One speaker from Wulanhaote, Inner Mongolia finds (222) and (223) acceptable. Interestingly, the same speaker reports the possibility of sequential homophonous particles, e.g. *de + de* in (247). This may indicate a general optionality of haplogy.

(222) ??钥匙 到底 带着 呢 没有 呢?
 ??Yàoshi dàodǐ dài-zhe **ne** méi-yǒu **ne**?
 key in.the.end carry-DUR DUR not-have CT
 Intended: ‘Do you have the keys?’ (elicited)

(223) A: Do you have the keys?

B: Yeah, I do.

A: ??那 手机 带着 呢 没有 呢?
 ??Nà shǒujī dài-zhe **ne** méi-yǒu **ne**?
 then cell.phone carry-DUR DUR not-have CT
 Intended: ‘Then do you have your *phone*?’ (elicited)

In section §6.8.6, we’ll see that a haplology constraint rules out the possibility of the two particles surfacing adjacently. Thus, one option is to say that the above examples are ruled out as cases of “distant haplology” of the kind discussed by Chan (1980: 60) governing the particles *-le*.¹¹⁸

6.8.5 *-ne*_{Asp} Occurs in Particle Questions

In section §6.6.2, we saw that *-ne* generally resists occurring in particle questions, as in (224), repeated from above. To account for this incompatibility, we posited the haplology constraint repeated in (225).

¹¹⁸Chan credits this term to Chen (1978).

(224) (He can dance.)

你 会 { 吗 | *呢 | *呢吗 | *吗呢 }?
Nǐ huì { ma | *ne | *ne-ma | *ma-ne }?
you can Y/N CT CT-Y/N Y/N-CT

‘Can you MA?’ (elicited)

(225) **Haplogy:** $/-ne_{CT} + -ma/ \rightarrow -ma$

When CT *-ne* and yes-no *-ma* morphemes co-occur, only *-ma* is pronounced.

However we also saw a few cases showing that contrary to the common claim (e.g. Li and Thompson 1981: 306, Li 2006: 29), sentence-final *-ne* can occur in particle questions. These fall into two classes, which we can now address in more detail. First, as Li (2004b: 37) observes, we find particle questions where *-ne* occurs instead of the regular yes-no particle *-ma*, as in (226–228).¹¹⁹

(226) 捆着 手 呢? 马 也 不 拉来!
Kǔn-zhe shǒu ne? Mǎ yě bù lā-lái!
tie-DUR hand DUR horse also not pull-come

‘Are your hands bound NE? You didn’t even bring the horse!’

(*Dream of the Red Chamber*, Ch. 29)

¹¹⁹The first example is from Cáo Xuěqín’s (曹雪芹) 18th century classic *Dream of the Red Chamber* (红楼梦). The others are from the mainland TV series *The Grand Mansion Gate* (大宅门).

(227) 跟 舅舅 还 保密 呢?
 Gēn jiùjiu hái bǎomì ne?
 with uncle still keep.secret DUR
 ‘Are you still keeping it a secret from uncle NE?’ (Grand Mansion Gate)

(228) 哟, 你 还 活着 呢?
 Yō, nǐ hái huó-zhe ne?
 whoa you still alive-DUR DUR
 ‘Whoa, you’re still alive NE?’¹²⁰ (Grand Mansion Gate)

Second, we have cases where *-ne* and *-ma* occur together, as observed by Lin (1984: 218), Gasde (2004: 317) and Li (2004b: 43).¹²¹ Four examples are given in (229–232).

(229) 你 没 看见 我 手里 做着 活 呢 吗?
 Nǐ méi kàn-jiàn wǒ shǒu-li zuò-zhe huó ne ma?
 you have.not see-RES my hand-LOC do-DUR work DUR Y/N
 ‘Didn’t you see that I’m working NE MA?’ (Ōta 1987: 344)

¹²⁰The original example was written with 呐, not 呢. This character can stand for the familiar morpheme *-ne* (cf. Chao 1968: 801), or may represent *-na*, which is a fusion of the particles *-ne* and *-(y)a* (Chao 1968: 797). Since, the potential presence of the “softening” particle *-(y)a* is not relevant to our purposes, I have assumed it is absent.

¹²¹Oddly enough, Lin’s (1984: 218) example of *-ne* and *-ma* occurring together is the same line from *Dream of the Red Chamber* that Li (2004b: 37) cites in (226) as having only *-ne*. It appears that different versions of the novel vary on this point, and both sentences are judged acceptable.

- (230) 这 不 正 想 法子 呢 吗?
 Zhè bú zhèng xiǎng fǎzi **ne ma**?
 this not DUR think method DUR Y/N
 ‘Aren’t we working on a solution NE MA?’ (Li 2004b: 43)
- (231) 这 不是 在 欺骗 消费者 呢 吗?
 Zhè bú-shì zài qīpiàn xiāofèizhě **ne ma**?
 this not-be DUR trick consumer DUR Y/N
 ‘Isn’t this tricking consumers NE MA?’ (online product review)
- (232) (Most importantly, the ending is abrupt.)
 是 想 写 续集 呢 吗?
 Shì xiǎng xiě xùjí **ne ma**?
 be think write sequel DUR Y/N
 ‘(Maybe) he’s thinking of writing a sequel NE MA?’ (online book review)

The first thing to observe about all of the examples in (226–232) is that they involve durative situations viewed as ongoing. This suggests that *-ne* in these examples is aspectual *-ne*, and that this morpheme isn’t subject to the same haplology constraint as CT *-ne*. To account for the cases where *-ne* occurs to the exclusion of *-ma*, we can make use of a separate haplology constraint governing the aspectual particle.¹²² Let’s assume that unlike the CT morpheme, aspectual *-ne* “beats out” the yes-no question particle when the two are underlyingly present:

¹²²Other cases are attested cross-linguistically of haplology constraints sensitive to the specific morphemes involved, rather than just blindly applying to any morpheme of the right phonological shape, as discussed by Stemberger (1981) and Neeleman and van de Koot (2006).

(233) **Haplology:** $/-ne_{\text{ASP}} + -ma/ \rightarrow -ne$

When aspectual *-ne* and yes-no *-ma* morphemes co-occur in the same clause, only *-ne* is pronounced.

This immediately accounts for (226–228). Furthermore, since *-ne* is always optional (like CT *-ne*, but unlike *-ma*), we aren't troubled by cases where aspectual *-ne* is licensed but *-ma* shows up instead, as in the following pair from Li (2004b: 45):¹²³

- (234) a. 你 还 没 吃 呢?
 Nǐ hái méi chī **ne**?
 you still have.not eat DUR
 'You still haven't eaten NE?' (underlyingly: $-ne_{\text{ASP}} + -ma$)
- b. 你 还 没 吃 吗?
 Nǐ hái méi chī **ma**?
 you still have.not eat Y/N
 'You still haven't eaten MA?' (underlyingly: $-ma$)

What about the cases of overt co-occurrence in (229–232)? Notice that each of these examples can be analyzed as having a bi-clausal structure. Here, if the haplology constraint only applies clause-internally, as specified in (233), we predict that aspectual *-ne* will be able to surface together with *-ma* just in case *-ne* is in a subordinate clause.¹²⁴ In fact, there is good reason to believe that aspectual *-ne* is embedded in these examples. Consider Ōta's (1987: 344) example repeated in (235a). First of all, we can note that the licensing durative predicate is the embedded *zuò* 'do', not the matrix *kàn-jàn* 'see-RES'.¹²⁵ Second, as (235b) shows, if we elide the sub-

¹²³I have changed 呐 to 呢 in this example, per the discussion in footnote 120.

¹²⁴Note that *-ma* is only possible in matrix clauses. See e.g. Gasde (2004: 317) and Hagstrom (2006: 180).

¹²⁵Following Smith (1997: 282), resultative verb complements like the *jiàn* in *kàn-jàn* 'see-RES' specify the resultant state of a telic event. Generally, such a telic situation would be incompatible with the imperfectivity of *-ne*. However, in this case, the negation *méi* 'have not' leads to the possibility of describing an ongoing state of not having reached the goal of the telic seeing event.

ordinate clause, *-ne* is no longer licensed. This behavior is easy to explain if *-ne* in (235a) is unambiguously positioned in the lower clause, and would be hard to explain otherwise.

- (235) a. 你 没 看见 我 手里 做着 活 呢 吗?
 Nǐ méi kàn-jiàn [wǒ shǒu-li zuò-zhe huó **ne**] **ma**?
 you have.not see-RES my hand-LOC do-DUR work DUR Y/N
 ‘Didn’t you see that I’m working NE MA?’ (Ōta 1987: 344)
- b. 我 手里 做着 活 呢。 你 没 看见 (*呢) 吗?
 Wǒ shǒu-li zuò-zhe huó **ne**. Nǐ méi kàn-jiàn (***ne**) **ma**?
 my hand-LOC do-DUR work DUR you have.not see-RES DUR Y/N
 ‘I’m working NE. Didn’t you see that (*NE) MA?’ (elicited)

Across a wider range of data, it appears that questions with *-ne* and *-ma* together can nearly always be analyzed as bi-clausal. For example, all 21 cases of such questions in a corpus of online product reviews conformed to this generalization.¹²⁶ Most often, the matrix verb was *shì* ‘be’, negated to create a rhetorical question, as in (231). Furthermore, in all of these examples, the subordinate predicate was durative. While clear mono-clausal cases of *-ne* and *-ma* together are attested elsewhere, as in (236), the speakers I’ve consulted are split on their acceptability. (I use the % sign to indicate varying acceptability across speakers or speech styles.) One simple way to explain this inter-speaker variation is to say that the haplology constraint governing aspectual *-ne* from (233) is only inviolable for some speakers.

This state of not having seen-to-conclusion would support *-ne* if it were viewed as ongoing, for example with the addition of *hái* ‘still’ in (235), to mean “You still haven’t seen it?”. However with *hái* absent, this meaning is not available, as (235b) shows.

¹²⁶The reviews came from the Chinese portion of the UMass Amherst Linguistics Sentiment Corpora (Constant et al. 2009), containing over 500,000 online product reviews from Amazon.cn.

- (236) a. %我的 衣服 带着 呢 吗?
 %Wǒ-de yīfu dài-zhe **ne ma**?
 me-POSS clothes carry-DUR DUR Y/N
 ‘Are you carrying my clothes NE MA?’ (web example)
- b. %北京 现在 下雨 呢 吗?
 %Běijīng xiànzài xià-yǔ **ne ma**?
 Beijing now fall-rain DUR Y/N
 ‘Is it raining in Beijing right now NE MA?’ (web example)

However, crucially, even for those speakers who accept mono-clausal co-occurrence of *-ne* and *-ma*, this depends on the availability of durative aspect. For example, the following example is reliably rejected, since the adjective *rè* ‘hot’ (and adjectives in general) resists durative aspect unless an adverbial like *háí* ‘still’ is present.

- (237) 北京 现在 热 (*呢) 吗?
 Běijīng xiànzài rè (***ne**) **ma**?
 Beijing now hot DUR Y/N
 ‘Is it hot in Beijing right now (*NE) MA?’ (elicited)

Similarly, the bi-clausal examples are crucially licensed by the durative aspect of the subordinate clause. For example, if we change Ōta’s (1987: 344) example to embed an adjectival predicate, durative aspect is ruled out, and the combination of *-ne* and *-ma* is no longer possible:

- (238) 你 没 看见 我手 很小 (*呢) 吗?
 Nǐ méi kàn-jiàn [wǒ shǒu hěn xiǎo (*ne)] ma?
 you have.not see-RES my hand very small DUR Y/N
 ‘Didn’t you see that my hands are small (*NE) MA?’ (elicited)

Overall then, the distribution of *-ne* in particle questions provides strong additional support for a formal separation of the aspectual *-ne* from CT *-ne*.

6.8.6 Haplology of *-ne_{Asp}* and *-ne_{CT}*

At this juncture, we’ve seen a range of evidence supporting the claim that there are two separate particles, *-ne_{Asp}* and *-ne_{CT}*. However if this is correct, there is a puzzle as to why (with few exceptions) we never see the two particles in the same sentence, even when both would be licensed. This section proposes an account of this restriction, making use of an additional haplology constraint, parallel to known constraints governing other homophonous pairs of clitics in the language.

Let’s first put aside the one case where the two particles *can* co-occur. This is when topic-marking *-ne_{CT}* occurs in the left periphery and sentence-final *-ne_{Asp}* occurs sentence-finally, as in the following attested example:¹²⁷

- (239) 其实 呢, 结局 还没 定 呢。
 Qíshí ne, jiéjú hái méi dìng ne.
 actually CT ending still have.not set DUR
 ‘Actually NE, the ending still isn’t decided NE.’ (web example)

However in any sentence where we would expect the two particles to show up in the same position, only one is licensed. For instance, in (240), from what we know of their distributions, both particles should be licensed sentence-finally, and yet only one is possible:

¹²⁷The original example appeared on an online forum and contained no punctuation. I have re-punctuated the sentence in line with native speaker intuitions.

- (240) 我 还 以为 他 正 忙着 呢 (*呢)!
 Wǒ hái yǐwéi tā zhèng máng-zhe **ne** (***ne**)!
 I still think.wrongly he DUR busy-DUR PRT PRT
 ‘And I thought he was in the middle of doing something NE!’ (elicited)

Similarly, both particles should be licensed on the fragment question in (241) or the antecedent clause in (242), but at most one can be surface:

- (241) 要是 他 正 忙着 呢 (*呢)?
 Yàoshi tā zhèng máng-zhe **ne** (***ne**)?
 if he DUR busy-DUR PRT PRT
 ‘And if he’s in the middle of doing something NE?’ (elicited)

- (242) 要是 他 正 忙着 呢 (*呢), 你 就 别 打扰 他。
 Yàoshi tā zhèng máng-zhe **ne** (***ne**), nǐ jiù bié dǎrǎo tā.
 if he DUR busy-DUR PRT PRT you then don’t disturb him
 ‘If he’s in the middle of doing something NE, don’t disturb him.’ (elicited)

Let’s review for a moment the reasons why the two particles should be licensed in these three examples. First, in each of (240–242), the durative predicate *zhèng máng-zhe* ‘be in the middle of doing something’ licenses aspectual *-ne*, independently of the presence of CT meaning. Recall for instance that aspectual *-ne* is licensed in adverbial clauses—even those that resist CT *-ne*:

- (243) 因为 老师 正 忙着 呢, 所以 不应该 打扰 她。
 Yīnwèi lǎoshī zhèng máng-zhe **ne**, suǒyǐ bù-yīnggāi dǎrǎo tā.
 since teacher DUR busy-DUR DUR so not-should disturb her
 ‘Since the teacher is busy doing something NE, you shouldn’t disturb her.’ (elicited)

Furthermore, each of (240–242) licenses CT *-ne*, irrespective of the aspect. We know this is true because if we change the predicate to one that doesn’t support durative aspect, *-ne* is still possible, in any of the three examples. In fact, in the case of the

fragment question, *-ne* is not only possible in the absence of durative aspect, but it is necessary:

- (244) 要是 他 长得 不好看 *(呢)?
 Yàoshi tā zhǎngde bù-hǎokàn *(**ne**)?
 if he look not-good-looking CT
 ‘And if he’s not good-looking NE?’ (Lin 1984: 234)

To summarize, we have every reason to think that both *-ne_{ASP}* and *-ne_{CT}* should be licensed in (240–242), and yet they can’t co-occur. The solution that I would like to propose is grounded in what appears to be a general principle of Mandarin haplology:

(245) **Haplology of Homophonous Clitics**

When two homophonous clitics occur adjacently, only one is pronounced.

Two reflexes of this constraint are already known in the literature. One we’ve seen already, governing the co-occurrence of perfective verbal *-le* and inchoative sentence-final *-le* (which I’ve glossed as ASP here and elsewhere), as in (246). The other, observed by Chao (1968: 298) forbids adjacent occurrences of the particle *-de*, which has a wide range of functions including that of a nominalizer and a possessive marker. Example (247) illustrates haplology of nominalizing *-de* and possessive *-de*.

- (246) 火 灭了 { ∅ | *了 }。
 Huǒ miè-**le** { ∅ | ***le** }。
 fire go.out-PFV ASP ASP
 ‘The fire went out, and that is what I have to say.’
 (Li and Thompson 1981: 299–300)

(247) A: Whose basket is this?

B: 是 那个 卖 菜 的 { ∅ | *的 }。
Shì nèi-gè mài cài de { ∅ | *de }。
be that-CL sell vegetable NMLZ POSS POSS

‘It’s that vegetable vendor’s.’ (Chao 1968: 298)

In these examples, I assume that both morphemes are present underlyingly, but that one is realized with no phonological content. I’ve made an arbitrary choice in representing the *second* morpheme as the silent one, but see no way of defending a claim that the asymmetry goes one way or the other.

If (245) is a general principle of Mandarin, we account for the impossibility of two adjacent particles *-ne* without additional machinery. For instance, example (241) can be treated as containing both morphemes *-ne_{ASP}* and *-ne_{CT}*, but only realizing one overtly:

(248) 要是 他 正 忙着 呢 ∅?
Yàoshi tā zhèng máng-zhe ne ∅?
if he DUR busy-DUR DUR CT

‘And if he’s in the middle of doing something NE?’ (elicited)

Overall, in this section, we’ve seen there are good reasons for analyzing sentence-final *-ne* as ambiguous between a lower aspectual particle and a higher CT particle. More generally, this chapter has shown that across a diverse range of environments, the *non*-aspectual uses of *-ne* display the properties we expect of a CT marker. At the same time, we haven’t yet provided a formal analysis of the syntax/semantics of sentences containing CT *-ne*, or a model of how *-ne* comes to be realized in a particular position. The next chapter turns to these issues.

CHAPTER 7

TOWARD A FORMAL ANALYSIS OF MANDARIN -NE

This chapter sketches an analysis of Mandarin CT *-ne* within the framework developed in chapters §3 and §5. In particular, I propose that *-ne* spells out the CT operator, and that its linear positioning is subject to prosodic constraints similar to those governing the linearization of the English L-H% clitic. While certain details of the analysis remain to be worked out, the proposal can make sense of the observations that (i) *-ne* surfaces both on topics and sentence-finally, and that (ii) in CT+Exh examples, the viability of sentence-final CT *-ne* is correlated with the inability of the CT phrase to topicalize. To conclude the chapter, we'll take a step back and consider the prospects for analyzing other CT particles within the topic abstraction system.

7.1 *-ne* as Left-Peripheral CT Operator

Chapter §3 posited a CT operator occurring in the left periphery of a sentence. This high position was necessitated by the semantics of the operator itself, since the operator's output in the focus dimension is “nested”, and so resists further composition (see section §3.2). Furthermore, this left-peripheral position gave us an explanation of why CT phrases often overtly raise to the left periphery, as in CT topicalization structures, or are base-generated there, as in CT left-dislocation structures.

Chapter §6 argued that (aspectual uses aside) Mandarin *-ne* conveys CT meaning, but didn't yet locate *-ne* within any particular model of CT. Let's put these pieces together now. On the topic abstraction account, we understand CT phrases themselves simply as F-marked associates of the CT operator. Thus, there is no expect-

tation of finding any dedicated morpheme that marks CT phrases directly. Rather, a morpheme that conveys CT meaning receives a natural analysis as the CT operator itself.

The idea that *-ne* (in its sentence-final use at least) and other sentence-final Mandarin particles spell out abstract syntactic heads in the left periphery is not new. Both Li (2006) and Paul (to appear) argue that the Mandarin sentence-final particles can be successfully analyzed within the cartographic tradition (Rizzi 1997) as heads of distinct functional projections in the C-domain. These authors treat *-ne* specifically, although their particular proposals for its meaning and position differ.¹

The specific claim that I would like to make is that all instances of CT *-ne* are realizations of the CT operator. This implies taking Li's (2006) and Paul's (to appear) proposals a step further, and unifying topic-marking *-ne* with sentence-final CT *-ne*.² The main motivation for unifying across these categories is the fact that both topic-

¹For Li (2006), sentence-final *-ne* is an “evaluative marker” that heads a dedicated projection (EvaluativeP), and functions to mark declarative content as “extraordinary” or interrogative content as “of particular importance”. Paul (to appear) distinguishes three uses of sentence-final *-ne*, and assumes they occupy three distinct positions within a split CP. The lowest *-ne* indicates a continuing state; this is the aspectual use of *-ne* discussed in section §6.8. The middle *-ne* occurs within the Force domain and marks follow-up questions. For me, these would be cases of CT *-ne*. The highest *-ne* is described as conveying exaggeration, and occurring in an AttitudeP, above ForceP, although no examples are provided.

²Both authors in fact explicitly reject this option. Li (2006) argues for separating sentence-final uses of *-ne* from topic-marking and fragment question uses based on a perceived difference in meaning. Paul (to appear) argues that the two positions must correspond to distinct categories, since they can co-occur, as in (i). However there are at least two ways of explaining such data while holding on to the view that the two instances of *-ne* occur in the “same” position. First, given the existence of fragment questions with *-ne*, (i) could be analyzed as two separate clauses, as in “And me? Who will listen to what I say?”. Second, given the iterability of the CT operator, as needed to account for the multiple CT data in section §3.5, there is the possibility that each instance of *-ne* in (i) spells out a unique CT head. On Paul's view, this would be ruled out by a requirement that the topic projection be either uniformly “left-headed” or uniformly “right-headed”. However, if the position of *-ne* is sensitive to the prosodic structure (as I argue below), this problem doesn't arise.

(i) 我 呢, 谁 来 听 我 说 呢?
 Wǒ **ne**, shéi lái tīng wǒ shuō **ne**?
 me CT who come listen I say CT

‘And *me*, who will listen to what *I* say?’

(Paul to appear: fn. 32)

marking *-ne* and (non-aspectual) sentence-final *-ne* convey CT meaning, as argued in chapter §6. What remains to be explained is how one and the same operator surfaces in two different linear positions. For example, how is it that CT *-ne* is spelled out immediately following the sentence-initial topic in (1), but sentence-finally in (2)?

(1) **Topic-Marking *-ne***

(Every day mom doesn't come home until late.)

爸爸 呢, 干脆 就 不 回来。

Bàba **ne**, gāncuì jiù bù huí-lái.

dad CT simply just not return-come

'(And) dad NE, doesn't even come back at all.'

(Shao 1989: 174)

(2) **Sentence-Final *-ne***

A: His family is poor, so you'd do better not to interact with him.

B: 他 家 有 三 头 牛 呢。

Tā jiā yǒu sān tóu niú **ne**.

his family have three CL cow CT

'His family has three cows NE... (!)'

(Isn't that proof that they're not poor?)

(Tsao 2000: 16)

Deriving the position of topic-marking *-ne* is relatively simple. I assume that, as in English overt topicalization structures, Mandarin CT phrases can raise overtly to the position directly above the CT operator, where they are interpreted.³ This movement is illustrated below for the case of topic-marking *-ne* in (1):

³I assume furthermore that, as in English, there is the option of base-generating the CT phrase in this position, and having the CT operator bind a pronoun below. However I won't be concerned with these cases here.

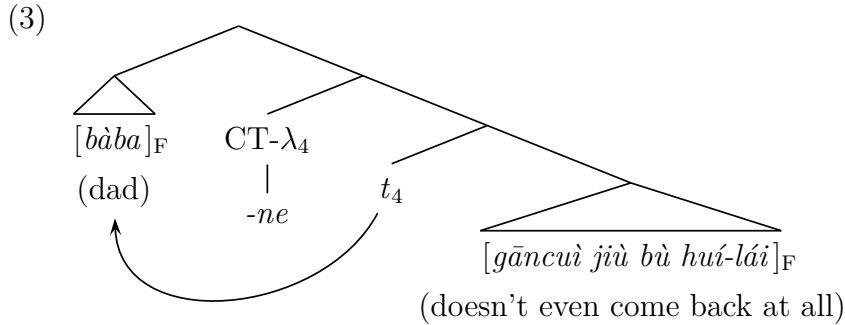

What about deriving sentence-final *-ne*? There are two broad styles of approach to this problem. One is to appeal again to syntactic movement. For example, to derive (2), we could simply raise the entire clause to the CT operator position:

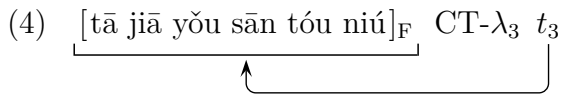

Recall from chapter §5 that this wasn't a viable approach to the English CT facts, since the CT morpheme (L-H%) can occur sentence-medially and what precedes it is not always a constituent (e.g. "I gave [FRED]_{CT} ... [the BEANS]_{Exh}"). By comparison, the purely syntactic approach seems, at first glance, better-suited to the Mandarin facts. With extremely few exceptions, the sentence-initial material preceding *-ne* is a constituent (either a topic, or an entire clause), so we can entertain the possibility that this material uniformly occupies the specifier of CT operator position. However, I will argue against this account shortly.

The second approach parallels the English analysis from chapter §5. Specifically, I argue that the CT operator is lexicalized as a clitic that needs to occur at the right edge of a large prosodic domain. We'll turn to this account now, and compare it along the way to the purely syntactic alternative.

7.2 *-ne* as IntP Clitic

It is a common informal observation that *-ne*, and other Mandarin discourse particles for that matter, typically occur at the right edge of a large prosodic unit. For the general claim, Tao (1996) suggests that Mandarin particles almost always appear at the end of an intonational unit (see Qin 2012: 14 for further discussion). With respect to *-ne* specifically, we've already seen that the particle is restricted to two positions: topic-marking and sentence-final. I take it as uncontroversial that sentence-final uses align with a large prosodic break. With the topic-marking uses, initial evidence also points to a mandatory break after *-ne*. For one, this is consistent with recurring claims that the topic-marking particle's entire purpose is to mark or create a pause (Chao 1968: 802, and many following). Additional evidence, discussed below, comes from comma usage in corpora. The formal claim that I would like to make, based on these initial findings, is that regardless of its linear position within the sentence, *-ne* needs to occur at the right edge of an intonational phrase. That is, just like the English CT morpheme L-H%, Mandarin *-ne* is an IntP enclitic.

Beyond impressionistic reports, we can find evidence by looking at the frequency that commas are present after *-ne*. While written commas don't necessarily map one-to-one onto prosodic breaks in speech, it nevertheless seems likely that in the case of Mandarin there is a strong correlation between one and the other. Figure 7.1 shows the frequency of comma usage following twelve common adverbial topics in the CCL corpus.⁴ To ensure that the adverbial is in topic position, I only counted occurrences where the adverbial is sentence-initial and followed by a pronoun or demonstrative.⁵

⁴Specifically, I used the modern subset of Peking University's Center for Chinese Linguistics (CCL) corpus, containing over 700 million characters of text from a wide range of written genres, published in post-imperial China (1911–present). Available at http://ccl.pku.edu.cn:8080/ccl_corpus/

⁵More precisely, I counted occurrences following a sentence-final punctuation mark (。 , ? , or !), and where the subsequent word (ignoring *-ne*) was one of the characters 我, 你, 她, 他, 它, 这 or 那 (*I, you, she, he, it, this or that*).

The comma frequency for each adverbial is shown both when *-ne* is present (e.g. ‘Actually NE, she ...’) and when it is absent (e.g. ‘Actually, she ...’). The main finding is that for each of the twelve adverbial topics, a comma is much more likely to follow when *-ne* is present. In fact, averaged over all tokens, a comma followed 93% of the time when *-ne* was present, compared to only 36% of the time when *-ne* was absent.⁶

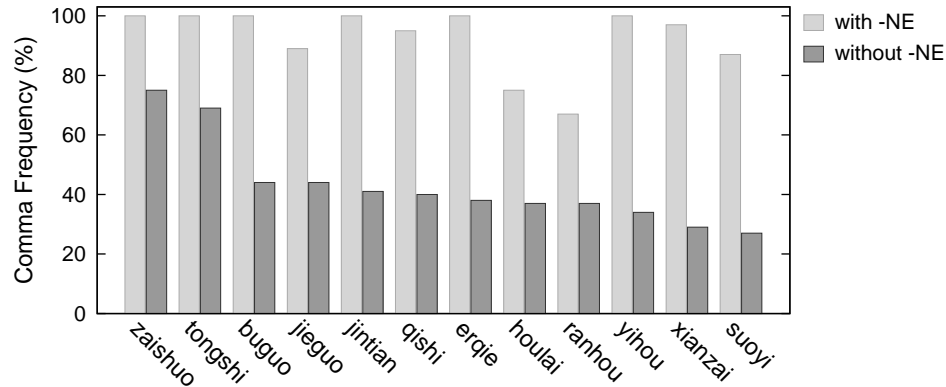

Figure 7.1: Comma usage following adverbial topics with and without *-ne*

Left to right, the adverbials are: *zàishuō* ‘furthermore’, *tóngshí* ‘similarly’, *búguò* ‘however’, *jiéguǒ* ‘in the end’, *jīntiān* ‘today’, *qíshí* ‘actually’, *èrqiě* ‘furthermore’, *hòulái* ‘afterward’, *ránhòu* ‘afterward’, *yǐhòu* ‘in the future’, *xiànzài* ‘at present’ and *suǒyǐ* ‘as a result’.

Based on these initial data, we can tentatively conclude that the presence of *-ne* correlates with a large prosodic break. One way of encoding this formally is to say that *-ne* is lexically specified as needing to occur at the edge of a large prosodic domain. Let’s assume that the domain in question is the intonational phrase (IntP). In this case, to understand the distribution of *-ne* we need to first know something about the distribution of IntP breaks.

⁶In total, there were 31,745 tokens of the twelve adverbials in the target position (sentence-initially, preceding a pronoun or demonstrative subject). Of these, 135 tokens had *-ne* marking the adverbial, while the remaining 31,610 tokens had no *-ne*.

7.3 Clause-Medial IntP Breaks and Pressure to Raise

In English, leaving a CT phrase in situ can result in an IntP break sentence-medially:

- (5) (What about MARY? What did you give HER?)

I gave [MARY]_{CT} ... [the ORANGES]_{Exh.}
 L+H* L-H% H* L-L%

By contrast, *-ne* is generally unable to occur in these medial positions:

- (6) (And what do you feed the *tigers*?)

我们 喂 老虎 (*呢) 羊肉。

Wǒmen wèi lǎohǔ (*ne) yáng ròu.

we feed tiger CT mutton

‘We feed the tigers (*NE) mutton.’ (elicited)

One way of understanding the fact that *-ne* doesn’t typically occur sentence-medially is to maintain that Mandarin has a stronger aversion than English to placing an intonational break in a clause-medial position. In terms of the constraint system discussed in chapter §5, this could be achieved by ranking Selkirk’s (2011b) MATCH-CLAUSE relatively high, encoding a strong pressure for IntPs to “match” full clauses. If *-ne* can only be realized at an IntP boundary, this analysis captures the impossibility of medial *-ne* in a case like (6). Importantly, this analysis has consequences beyond the distribution of *-ne*. The larger prediction is that regardless of the presence of *-ne*, (6) should be degraded to the degree that a large prosodic break follows *lǎohǔ* ‘tiger’. This prediction is not easily (dis-)confirmed by speaker intuitions, and calls for careful experimental work. This awaits further research.

Given the hypothesized restriction against clause-medial breaks, how would an input containing *-ne* be realized at all in a case like (6)? As discussed in section §5.7, we can understand the prosodic problems with examples leaving a CT in situ as pressure towards raising the CT to a higher position (or base-generating it there), precisely if the resulting ex-situ structures lead to a better profile on the relevant

prosodic constraints. Indeed, the meaning intended in (6) can be realized with *-ne* via topicalization or left-dislocation, lending support to this understanding:⁷

(7) (And what do you feed the *tigers*?)

老虎 呢, 我们 喂 (它) 羊肉。

Lǎohǔ **ne**, wǒmen wèi (tā) yáng ròu.

tiger CT we feed it mutton

‘The tigers NE, we feed (them) mutton.’ (elicited)

Of course, the contrast between (6) and (7) would also be captured by the purely syntactic account holding that *-ne* is always spelled out in the left periphery and that what precedes it occurs in its specifier. On this account, (6) is ruled out because the material preceding *-ne* isn’t a constituent. But one problem for this view is a class of exceptions, where *-ne* can in fact occur sentence-medially. These examples have not, to my knowledge, been discussed in the literature, and they are rare enough that I have not seen an example attested in a corpus. Nevertheless, the speakers I have consulted accept *-ne* in the following context:

⁷To formally capture the superiority of the phrasing in (7), we would need to address various details of MATCH-CLAUSE. On Selkirk’s (2011b) official proposal, MATCH-CLAUSE is decomposed into two constraints, one for each direction of correspondence. Specifically we have the S-P faithfulness constraint MATCH(CP, INTP) and the P-S faithfulness constraint MATCH(INTP, CP). If Mandarin ranks the latter constraint high, this will require that every IntP break occur at a clause boundary. Ideally this would create a preference for (7) over (6). However, while the constraint is clearly violated in the case of (6), it’s not clear that (7) performs any better, since the initial IntP (*lǎohǔ -ne*)_{IntP} doesn’t correspond to any CP. Another option would be to use the S-P constraint MATCH(CP, INTP), asking that every CP correspond to an IntP. This constraint is obeyed in (7). However whether it is violated in (6) depends on whether we allow the possibility of recursive IntP structures, such that a single larger IntP contains the two smaller IntPs.

(8) 老师 让 张三 写 两篇 文章。
Lǎoshī ràng Zhāngsān xiě liǎng-piān wénzhāng.
teacher have Zhāngsān write two-CL essay

可是 他 让 李四 呢, 写 四篇 文章。
Kěshì tā ràng Lǐsì **ne**, xiě sì-piān wénzhāng.
but he have Lǐsì CT write four-CL essay

‘The teacher had Zhāngsān write two essays.

But he had Lǐsì NE, write four essays.’ (elicited)

This sentence is a challenge for the syntactic account, since the string preceding *-ne* is not a constituent, and thus can’t be located in the specifier of *-ne*. Furthermore, two additional observations about this example suggest that the prosodic account is on the right track. First, as always, there is a clear prosodic break after *-ne*, as indicated by the comma. Second, topicalization is judged as odd in this context, as shown in (9). It remains to be seen what prevents topicalization here. But regardless of the reason, the prosodic account seems right in drawing a connection between (i) whether *-ne* can mark a non-raised CT, and (ii) whether raising the CT would be a viable, preferable alternative.

(9) 老师 让 张三 写 两篇 文章。
Lǎoshī ràng Zhāngsān xiě liǎng-piān wénzhāng.
teacher have Zhāngsān write two-CL essay

??李四, 他 让 写 四篇 文章。
??Lǐsì, tā ràng xiě sì-piān wénzhāng.
Lǐsì he have write four-CL essay

‘The teacher had Zhāngsān write two essays.

Lǐsì, he had write four essays.’ (elicited)

7.4 Sentence-Final *-ne*

On the tentative prosodic analysis of Mandarin considered above, the basic predictions are as follows:

- (10) a. *-ne* is realized at the right edge of an intonational phrase.
 b. An intonational break can separate a left-peripheral (syntactic) topic from the rest of the clause, but can't (generally) occur sentence-medially.

From these predictions, we derive a corollary prediction—that in sentences where the CT doesn't occur in the left periphery, the sentence will (generally) be phrased as one IntP. As an IntP clitic, we then predict that *-ne* will be realized sentence-finally, paralleling the cases of English lone CT. Thus, we can maintain that the broad sentential CT in (11) and the predicate CT in (12) both stay in situ, and still capture the fact that *-ne* appears sentence-finally:

(11) A: His family is poor, so you'd do better not to interact with him.

B: 他 家 有 三 头 牛 呢。

Tā jiā yǒu sān tóu niú **ne**.

his family have three CL cow CT

'His family has three cows NE... (!)'

(Isn't that proof that they're not poor?) (Tsao 2000: 16)

(12) A: Is Zhāngsān going to the conference?

B: 他 跟 我 说 要 去 呢, (但是 他 还 没 买 机 票。)

Tā gēn wǒ SHUŌ yào qù **ne**... (dànshì tā hái méi mǎi jī-piào.)

he with me say will go CT but he still have.not buy plane-ticket

'He *told* me he's going NE... (but he still hasn't bought a ticket.)'

(elicited)

Turning back to CT+Exh examples, we've already seen an explanation of the *possibility* of topic-marking *-ne* (given topicalization or left-dislocation). However we still have to ask what prevents *-ne* from surfacing finally when the CT phrase stays in situ, as follows:

(13) (And what do you feed the *tigers*?)

我们 喂 老虎 羊肉 (??呢)。

Wǒmen wèi lǎohǔ yáng ròu (??ne).

we feed tiger mutton CT

‘We feed the tigers mutton (??NE).’ (elicited)

All else being equal, (13) should be preferred over a structure like (7) that realizes the CT phrase ‘tiger’ in the left periphery followed directly by *-ne*, since (13) makes do without any overt movement (obeying STAY) and with less intonational phrases (better satisfying *INTP). To rule this otherwise preferable form out, I assume that like English, Mandarin foci prefer to be phrased in separate prosodic domains. This assumption is consistent with the observation that Mandarin alternative-generating foci receive a high level of prominence, implemented as increased duration and pitch range (Xu 1999, 2004). A natural way of representing this phonetic effect in the phonology is to say that focused phrases contain the head of a large prosodic domain (e.g. IntP). On a parallel with the English system, we could implement this requirement using a constraint like FOCUS-PROMINENCE. However, I won’t speculate on whether this precise formation is appropriate for Mandarin here.

Let’s move forward with the assumption that in Mandarin, as in English, there is a pressure for sentences containing two alternative-generating foci to phrase those two foci in separate IntP domains. It is then on precisely this count that (13) is sub-optimal, and in particular, inferior to (7). To summarize then, we hypothesize that Mandarin CT+Exh sentences leaving the CT phrase in situ are generally ruled out because (i) a sentence-medial IntP break between CT and Exh is (with few exceptions) disallowed, and (ii) the lack of a sentence-medial IntP break results in phrasing the two focal elements together, violating FOCUS-PROMINENCE.

In line with Féry’s (2007) proposal discussed in §5.7, this analysis understands overt topicalization as a response to the need to separate a topic from a focus prosod-

ically. Thus, in CT questions, which lack an Exh phrase, we predict that the CT phrase will remain in situ, and *-ne* will surface sentence finally. This is exactly what we find in examples like (14). Furthermore, as expected on the prosodic account, there is no significant break between the subject and the predicate.⁸

(14) (You understand now.)

他 懂不懂 呢?
 Tā dǒng-bù-dǒng **ne**?
 he understand-not-understand CT
 ‘(But) does *he* understand NE?’ (Chao 1968: 802)

A great deal of work remains to be done in testing the various assumptions we’ve made along the way. Most pressingly, careful experimental work is needed to ground even the most basic claims about Mandarin prosodic structure, and much of this work has not yet been undertaken.⁹ Nevertheless, the prosodic account given above is promising in that it draws connections between the ability of CT to topicalize and the position of *-ne*. Specifically, the prediction is that in cases where the CT can’t topicalize, CT+Exh will be realized as one IntP and *-ne* will surface sentence-finally. Let’s now explore one case where this prediction seems to be on the right track.

⁸One remaining question is why the equivalents of many English lone CT declaratives are not acceptable as *-ne*-final sentences in Mandarin. For example, as a response to the question “Did your parents like the movie?”, I can answer “My [MOM]_{CT} didn’t... but my [DAD]_{CT} did...”, whereas in Mandarin sentence-final *-ne* is judged as at least somewhat degraded on either clause:

- (i) A: 你 爸妈 看了 电影 觉得 不错 吧?
 Nǐ bà-mā kàn-le diànyǐng juéde bù-cuò ba?
 your dad-mom watch-ASP movie think not-bad PRT
 ‘Did your parents like the movie?’
- B: 我 妈 不 喜欢 (??呢)。 我 爸 倒 挺 喜欢 (?呢)。
 Wǒ mā bù xǐhuan (??ne). Wǒ bà dào tǐng xǐhuan (?ne).
 my mom not like CT my dad on.contrary quite like CT
 ‘My mom didn’t like it. But my dad did.’ (elicited)

⁹See Peng et al. 2006 for a promising beginning.

In section §6.7, we saw that sentence-final *-ne* regularly co-occurs with the adverb *hái* ‘also’, as in (15). However we haven’t yet given an explicit analysis of the information structure of such sentences. Before we can derive the positioning of *-ne*, we need to answer the simpler question—which constituents in (15) are CT and Exh?

- (15) 我 还 给了 爷爷 一 个 呢。
 Wǒ hái gěi-le YÉYE yī gè **ne**.
 I also give-PFV grandpa one CL CT
 ‘I also gave one to *grandpa* NE.’ (elicited)

Krifka (1998: ex. 15) promotes the hypothesis that the associates of additive particles like *too* and *also* are always contrastive topics. If this were the case, then we could conclude that ‘grandpa’ in (15) is the CT phrase associating with *-ne*. However the intonational facts of English suggest that things aren’t so simple. In (16), either the additive particle or its associate can be CT:

- (16) a. I gave [GRANDPA]_{CT} ... one [TOO]_{Exh}.
 L+H*L-H% H* L-L%
- b. I [ALSO]_{CT} ... gave [GRANDPA]_{Exh} one.
 L+H* L-H% H* L-L%

When Mandarin *hái* ‘also’ co-occurs with final CT *-ne*, it turns out there is good reason to think that the adverb itself, rather than its associate, is the CT phrase. We can see this in the viability of different preceding questions. If *hái* is the CT, we expect a preceding question of the form “Who else did you give one to?”. Indeed, such a dialogue is possible. That is, (15) can be a response to the question in (17), where the question contains the same adverb *hái*.

- (17) 你 还 给了 谁 (呢)?
 Nǐ hái gěi-le shéi (ne)?
 you also give-PFV who CT
 ‘(And) who else did you give (one) to (NE)?’ (elicited)

On the other hand, if the CT phrase in the answer were ‘grandpa’, we would expect the statement to be responding to a question along the lines of “And what about grandpa? Did you give him one?”. However, as (18) shows, such a dialogue doesn’t support the use of *-ne* on the response:

- (18) A: 那 爷爷 呢? 你 有没有 给 爷爷 一 个 (呢)?
 Nà yéye ne? Nǐ yǒu-méi-yǒu gěi yéye yī gè (ne)?
 then grandpa CT you have-not-have give grandpa one CL CT
 ‘What about grandpa? Did you give him one?’
 B: 嗯, 我 还 给了 爷爷 一 个 (#呢)。
 Èn, wǒ hái gěi-le yéye yī gè (#ne).
 yeah I also give-PFV grandpa one CL CT
 ‘Yeah, I also gave one to grandpa (#NE).’ (elicited)

Given the facts above, the most plausible analysis of (15) is as follows, where *hái* is the CT associate of *-ne*, and ‘grandpa’ is an exhaustive focus:

- (19) 我 还 给了 爷爷 一 个 呢。
 Wǒ [hái]_{CT} gěi-le [YÉYE]_{Exh} yī gè **ne**.
 I also give-PFV grandpa one CL CT
 ‘I [*also*]_{CT} gave one to [*grandpa*]_{Exh} NE.’

We’re now ready to think about the prosody of the example, and the positioning of *-ne*. One basic question is, if this is a CT+Exh example, why doesn’t the CT phrase topicalize, giving topic-marking *-ne*, as was required in the tiger-feeding examples (6), (7) and (13)? Here, the answer comes down to an apparent morpho-syntactic

restriction on the adverb. Unlike the nominal *lǎohǔ* ‘tigers’, the adverb *hái* ‘also’ can’t stand on its own as a syntactic topic:

- (20) *还 (呢) 我 给了 爷爷 一 个。
Hái (ne) wǒ gěi-le yéye yī gè.
 also CT I give-PFV grandpa one CL
 Intended: ‘Also (NE), I gave one to grandpa.’ (elicited)

Recall from (10) our hypotheses that (i) *-ne* cliticizes to the right edge of an IntP and that (ii) Mandarin generally disallows sentence-medial IntP breaks in the absence of topicalization. Together, these assumptions predict that since topicalization of the CT phrase is impossible in a case like (19), the sentence will be realized as a single intonational phrase, and *-ne* will be pronounced sentence-finally. In line with these predictions, native speakers confirm that there is subjectively very little or no pause after *hái* in (19), suggesting that the entire clause is indeed parsed as a single IntP.

7.5 Prospects for Other CT Particles

At this point, I hope to have shown that Mandarin *-ne* is a good candidate for the overt realization of the CT operator posited by the topic abstraction account. Turning things around, I would argue that the existence of a morpheme like *-ne* is in fact good evidence in favor of analyzing CT along the lines that we have: as a left-peripheral operator binding a focused associate. This fits well with the facts that (i) *-ne* can appear at a distance from the CT phrase, and that (ii) the CT phrase itself receives no special marking besides the prominence typically associated with focus.

In this final section, I briefly consider the prospects for analyzing other CT particles in similar terms. The best known CT particle is Japanese contrastive *-wa*, as discussed in section §2.5. However, there are several obstacles to analyzing *-wa* on the topic abstraction account. First of all, the same particle *-wa* marks both contrastive and non-contrastive (or “thematic”) topics. If this isn’t just a coincidence of

the Japanese lexicon, then there is some common core underlying all *-wa*-marking, and it won't do to simply treat *-wa* uniformly as the realization of the CT operator. For recent discussion of the hope and challenge of unifying across all uses of *-wa*, see Heycock (2008), Tomioka (2010a) and Vermeulen (2013).

But even if we're willing to posit an ambiguity between contrastive and non-contrastive *-wa*, it isn't obvious how to derive the position of CT *-wa* under the topic abstraction analysis. Unlike Mandarin *-ne*, Japanese CT *-wa* typically occurs directly marking the CT phrase, even when that phrase remains in situ:

- (21) John-ga PAI-**wa** tabe-ta ga KEEKI-wa tabe-nak-atta.
 John-NOM pie-TOP eat-PAST but cake-TOP eat-NEG-PAST

‘John ate the *pie*, but he didn't eat the *cake*.’ (Fiengo and McClure 2002: 30)

If *-wa* in (21) spells out the left-peripheral CT operator, it is difficult to explain why it would be linearized adjacent to the CT phrase ‘pie’. Thus, it seems unlikely that CT *-wa* is a head in the left periphery. Could *-wa* be the realization of a feature on the CT phrase itself, along the lines of Büring's (2003) CT-marking analysis? This too is doubtful, since recall that *-wa* can appear at a distance from the CT phrase, just in case the latter occurs within an island:

- (22) a. Itsumo [CHOMSKY-ga kai-ta hon]-**wa** shuppan sa-re-ru.
 always Chomsky-NOM write-PAST book-TOP publish do-PASS-NONPAST
 ‘[The books that [*Chomsky*]_{CT} writes] are always published...’
- b. *Itsumo [CHOMSKY-**wa** kai-ta hon]-ga shuppan sa-re-ru.
 always Chomsky-TOP write-PAST book-NOM publish do-PASS-NONPAST
 ‘[The books that [*Chomsky*]_{CT} writes] are always published...’

(Hara 2006: 73–74)

If we believe that CT constructions always involve a CT operator above binding a focused constituent below, then it appears that the morpheme *-wa* is in fact something of an intermediary, intervening between these two pieces. Taking an analogy to wh-

questions, *-wa* would be the equivalent of what Cable (2007) terms a Q-PARTICLE. On Cable’s analysis of *wh-* questions, Q-particles mediate between the *wh-* question operator above and the focused *wh-* word below. Like Q-particles, Japanese CT *-wa* can be plausibly analyzed as marking the edge of the phrase that undergoes movement to the operator position, explaining the island sensitivity in (22). See Davis (2010) for an analysis of *-wa* along these lines. However it remains unclear whether *-wa* would have any role to play in semantic composition (as Q-particles do on Cable’s model), or if it would simply be vacuous.

To end on a more promising note, recall the facts of Paraguayan Guaraní from section §3.6.3. Based on Tonhauser’s (2012) description, the Guaraní clitic *-katu* is an excellent candidate for a manifestation of the CT operator. Specifically, *-katu* is a second-position clitic that marks the presence of a CT, but doesn’t “track” the position of the CT phrase. For instance, while (23) and (24) differ as to which nominal is interpreted as CT, *-katu* cliticizes to the subject in either case, and Tonhauser reports no surface distinction between the two sentences.

(23) A: Juana was born in Argentina. Where was Bob born?

B: BOB-**katu** o-nasẽ ESTADO UNIDO-pe.

Bob-CT A3-born America-in

‘[**Bob**]_{CT} was born in [the US]_{Exh}.’ (Tonhauser 2012: ex. 25a)

(24) A: Juana was born in Argentina. Who was born in the US?

B: BOB-**katu** o-nasẽ ESTADO UNIDO-pe.

Bob-CT A3-born America-in

‘[Bob]_{Exh} was born in [**the US**]_{CT}.’ (Tonhauser 2012: ex. 25b)

On the topic abstraction account, we can capture this distribution by saying that *-katu* spells out the CT operator position, and cliticizes to the first available prosodic unit (irrespective of whether this corresponds to the CT phrase it binds or not). Since the CT phrase itself is nothing more than the F-marked associate of the CT

operator, there is no expectation that it will display any distinguishing characteristics beyond the general reflexes of alternative-generating focus (F). And since we take both CT and Exh to bear F-marks, it is unsurprising to find cases where swapping which phrase is CT and which is Exh has no visible effect.

CHAPTER 8

CONCLUSION

To conclude, I'd like to offer a brief summary of what happened over the last few hundred pages (though for a more detailed synopsis, see chapter §1), and also to mention some of what didn't happen and speculate on directions for future research.

8.1 Overview

Overall, the thesis aimed to develop a unified model of contrastive topic meaning and realization. Chapters §2–§4 provided an explicit answer to the question of what a contrastive topic is. Technically, it is any phrase interpreted as the sister to the CT operator. Given that operator's semantics, two consequences of this definition are that (i) any sentence containing a CT will appear in a discourse that addresses a complex question “sorted” into multiple smaller questions, and that (ii) these smaller questions will address alternatives to the denotation of the CT phrase.

It is a historical accident that CT+Exh examples have stolen the spotlight in most discussions of contrastive topic. Our structural definition of CT handles not just CT+Exh, but also Exh+CT, lone CT (including sentential CT), multiple CT (including complex and nested structures), and CT questions. I hope to have strengthened the case that it is both possible and attractive to treat all these constructions under a unified theory. Moving forward, I expect that studying lone CT would actually be the better “starting place” for typological research on CT, and will lead to more direct results and a better core understanding of CT itself. In retrospect, CT+Exh is

better understood as a multiple focus construction whose overall effect derives from the sum of its parts.

The semantic effect of CT constructions is to mark anaphora to a sorted question or “discourse strategy”. The pragmatic result of this anaphora is that these constructions convey a lack of resolution or “partiality”. In turn, this explains both the inability of maximal elements to stand as CTs, and the inability of fully resolving answers to contain CTs.

Syntactically, the proposal differs from most previous accounts in assuming that CTs are uniformly interpreted in a left-peripheral position, and need to either be generated in this position, or else move there via overt or covert movement. Covertly raising an in-situ CT phrase was a prerequisite for its interpretation as CT, but also led us to expect a subtle pattern of island effects, which were shown to be detectable across several languages.

Another critical feature of the account is that CT constructions are treated as focus constructions. That is, CT phrases bear the same alternative-generating F-marks as the focus associates of more familiar focus-sensitive operators like *even* and *only*. Indeed, the choice of binding operator is claimed to be the only factor distinguishing these foci. This unifying move has important consequences in both the semantics and the phonology.

The semantics we ascribed to CT constructions guarantee that the CT phrase is of the same semantic type as the alternatives it is being contrasted with. This led to a puzzle, in that when apparently quantificational nominals like ‘some grads’ are CT-marked, they typically contrast with individuals or pluralities, not generalized quantifiers. The solution I proposed is that (with few exceptions) when such nominals are CT-marked, they receive type-e readings. Consequently, the ability to be CT-marked (in a discourse contrasting individuals or pluralities) can be used to diagnose whether a nominal can be entity-denoting. Robustly quantificational nominals were

shown to resist CT, except in a limited set of contexts that “sort by proportions”. Additionally, as a side-effect of the process by which the CT operator composes in the semantics, we make what appears to be an accurate prediction that truly quantificational CTs always take low scope.

The view that CT phrases are focus associates of a CT operator has consequences for the phonology as well. It implies that cross-linguistically CT phrases should have all the phonological properties of F-marked constituents—for instance, in English, bearing a high level of prominence—and suggests that they have no dedicated phonological status beyond that. Since on the surface, English CT phrases do appear to have a dedicated “rising” prosodic realization, we explored how this might be captured. The basic proposal is that English pronounces the left-peripheral CT operator overtly, and that the distinctive “CT contour” is the result of this rising tonal morpheme being spelled out at the right edge of a nearby prosodic boundary. Determining the exact position where this tonal CT clitic is realized was argued to depend on a model of how prosodic structure is built, including constraints at the syntax-phonology interface.

Last of all, we turned to the Mandarin CT particle *-ne*. While this particle has gone virtually unmentioned in the contrastive topic literature, I believe it can tell us a great deal about the structure of CT constructions. One point of relevance is that *-ne* often sits in sentence-final position marking the presence of a CT phrase at a distance. This distribution supports the idea that CT constructions consist of an operator binding a focused phrase within its scope. Additionally, *-ne* occurs in an extremely wide range of constructions (including questions) that mirror the diversity observed in English. This offers further support that lone CT, sentential CT, and CT questions all fit under the same umbrella.

8.2 Remaining Work

Many important questions were left unanswered, and the study of contrastive topic remains a rich area for future research. One outstanding question concerns the theoretical status of the exhaustive foci that I've marked as "Exh" throughout. This shorthand served to mark foci that provided the answer to the immediate question under discussion, thereby distinguishing them from CTs. But is something additional needed to account for the exhaustive interpretation of these answer-foci? Are they, like CTs, the associate of a focus operator in a fixed position—this time an exhaustivity operator?

As far as how CT is realized cross-linguistically, our attention centered on English and Mandarin, and strayed only briefly to other languages like Czech, Dholuo, German, Guaraní, Hungarian, Japanese, Korean, and Turkish. As such, we got a close-up look at prosodic and particle-driven strategies for marking CT, but didn't explore in detail the syntactic mechanisms of topicalization and clitic left dislocation that are claimed to play a major role in CT-marking in languages like Czech, Hungarian and Italian. Broadly speaking, the topic abstraction account seems like a good candidate for explaining the tendency of CTs to move. Since this account holds that all CT phrases raise to the CT operator position at LF, the possibility of forcing overt movement in a particular language could be as simple as accounting for why that language disallows covert CT movement. However, the broad strokes of this explanation overlook a number of details that should be explored further. Is it true, as work in the cartographic tradition has argued, that (moved) CTs occur in a fixed position in the left periphery? Do languages that mark CTs via overt movement have additional restrictions on what types of phrases can be CT-marked?

While we made progress in understanding the effects of CT-marking on English sentence prosody, more work is needed to test the predictions of the account experimentally, with attention to the fine-grain details of realization that would distinguish

this from competing accounts. For instance, a major motivation for the SPC-driven account of English CT realization was the assumed asymmetry between CT+Exh and Exh+CT phrasing. Testing the validity of this assumption is a prerequisite to further theoretical development in this area. Controlled experiments will also be helpful in verifying the presumed phrasing differences between nested and complex CT, and in assessing the ability of multiple CT sentences to convey “sorted” readings where one CT out-scopes another.

Since the analysis of Mandarin topic-marking and sentence-final *-ne* as CT is new, there are a great many details still to be worked out. Most pressingly, for most of the *-ne*-marked sentences that we described as requiring CT discourses, we didn’t yet commit to a particular logical form specifying which constituents were CT and which if any were Exh. This additional project will allow us to test and refine the analysis of *-ne* as CT, and will likely benefit from a more thorough look at the interaction between *-ne* and the prosodic features of the containing sentence. Overall, while the parallels between CT-marking *-ne* and the English CT contour are remarkable, there are undoubtably certain differences that remain between the two markers. For one, we saw that *-ne* is essentially always optional, while English CT prosody can be a necessity. Another important feature of *-ne* that should be investigated more fully is its directionality. Largely, *-ne* appears to look backwards for contrast (implying an earlier contrastive topic), suggesting that forward-looking uses are restricted and may be ruled out in certain contexts. This is unexplained by the topic abstraction model, and so demands additional analysis. Finally, I should reiterate that the Mandarin data throughout are based primarily on the judgments of speakers from northern mainland China, the majority from Beijing and Hebei. The degree of variation in *-ne* usage across dialects has yet to be systematically explored, and this exploration is an important step before we can make robust claims about Mandarin in general.

One final issue that deserves a closer look is the question of how contrastive topics fit into the larger class of information structural categories. We were, I think, justified in defining and analyzing CT independently of “topicality”. While cross-linguistically, the elements languages mark as CTs are *often* topics in the sense of what an utterance is “about”, they certainly aren’t always so. Thus an analysis of what makes a CT a CT is needed regardless of what we say about topics more generally. Nevertheless, there is an interesting remaining question about the relation between CTs and aboutness topics. Would it be possible to define the features of a broader information structure category that covers both of these so-called “topics”? Precisely what is it that contrastive and non-contrastive topics have in common?

APPENDIX

NOTATIONAL CONVENTIONS

This appendix describes the notational conventions used in the dissertation.

Problematic examples are marked with the symbols in Figure A.1. The star of ungrammaticality marks examples that are consistently unacceptable across any context of utterance. By contrast, the infelicity mark ‘#’ applies to examples that are bad in the context provided, but would be good in some other context. Note that this usage doesn’t depend on the linguistic analysis of the sentence in question, and differs from the usage of authors who write ‘*’ to indicate a syntactic problem and ‘#’ to indicate a semantic problem.

*	ungrammatical
#	infelicitous in the given context
??	very unnatural
?	unnatural
(?)	slightly unnatural
%	acceptability varies across speakers or dialects

Figure A.1: Conventions for marking problematic examples

Inside parentheses, a mark of unacceptability means the example is bad if the parenthetical material is present, but good otherwise. Outside parentheses, a mark of unacceptability means the example is bad if the parenthetical material is absent, but good otherwise. For instance:

- | | | |
|--------|--|------------|
| (1) a. | This sentence is (completely) grammatical. | Optional |
| b. | This sentence is (*very) grammatical. | Impossible |
| c. | This sentence *(is) grammatical. | Required |

Example numbers in the dissertation restart from (1) every chapter. Thus a particular example could be cited as Ch. §3 ex. 17, or as (3.17) for short.

The abbreviations used in glossing examples from non-English languages are given in Figure A.2 on the following page.

A3	Paraguayan Guaraní “set A” 3rd person cross-reference marker
ACC	accusative case
ASP	aspectual particle (Mandarin sentence-final <i>-le</i>)
AUX	auxiliary verb
BA	Mandarin fronted object marker (<i>bǎ</i>)
CL	classifier
COMP	comparative
COND	conditional
CT	contrastive topic
DAT	dative case
DECL	declarative
DE	Mandarin modifier marker (<i>de</i>)
DISTR	distributive
DUR	durative aspect
EMPH	emphatic
EVID	evidential
EXH	exhortative
EXP	experiential aspect (e.g. Mandarin <i>-guo</i>)
IMP	imperative
LOC	locative
NEG	negation
NMLZ	nominalizer
NOM	nominative case
NONPAST	non-past tense
PASS	passive
PAST	past tense
PFV	perfective aspect
PL	plural
POSS	possessive
PRT	discourse particle (e.g. Mandarin sentence-final <i>a</i> , <i>ba</i>)
Q	question particle
RES	resultative
SG	singular
TOP	topic

Figure A.2: Glossing abbreviations

BIBLIOGRAPHY

- Abusch, Dorit. 1994. The Scope of Indefinites. *Natural Language Semantics* 2(2): 83–135.
- Aissen, Judith L. 1992. Topic and Focus in Mayan. *Language* 68(1):43–80.
- Alleton, Viviane. 1981. Final particles and expression of modality in modern Chinese. *Journal of Chinese Linguistics* 9(1):91–115.
- Anderson, Stephen R. 1972. How to get ‘even’. *Language* 48(4):893–906.
- Aoun, Joseph, and Yen-hui Audrey Li. 1993. Wh-Elements in Situ: Syntax or LF? *Linguistic Inquiry* 24(2):199–238.
- Artstein, Ron. 2004. Focus Below the Word Level. *Natural Language Semantics* 12(1): 1–22.
- Baker, C. L. 1970. Notes on the Description of English Questions: The Role of an Abstract Question Morpheme. *Foundations of Language* 6(2):197–219.
- Bartels, Christine. 1997. Towards a compositional interpretation of English statement and question intonation. Ph.D. thesis, University of Massachusetts, Amherst.
- Barwise, Jon, and Robin Cooper. 1981. Generalized Quantifiers and Natural Language. *Linguistics and Philosophy* 4(2):159–219.
- Beck, Sigrid. 2006. Intervention Effects Follow from Focus Interpretation. *Natural Language Semantics* 14(1):1–56.
- Beckman, Mary E., and Gayle Ayers Elam. 1997. *Guidelines for ToBI Labelling, version 3*. Ohio State Research Foundation.
- Beckman, Mary E., and Janet B. Pierrehumbert. 1986. Intonational Structure in Japanese and English. *Phonology Yearbook* 3:255–309.
- Benincà, Paola, and Cecilia Poletto. 2004. Topic, Focus, and V2: Defining the CP Sublayers. In *The Structure of CP and IP: The Cartography of Syntactic Structures*, ed. Luigi Rizzi, vol. 2. Oxford University Press.
- van den Berg, Martin H. 1996. Some aspects of the Internal Structure of Discourse: The Dynamics of Nominal Anaphora. Ph.D. thesis, University of Amsterdam.

- Bianchi, Valentina, and Mara Frascarelli. 2010. Is Topic a Root Phenomenon? *Iberia* 2(1):43–88.
- Biezma, María. 2009. Alternative vs. Polar Questions: The Cornering Effect. In *Proceedings of Semantics and Linguistic Theory (SALT) 19*. Ohio State University.
- Biezma, María, and Kyle Rawlins. 2012. Responding to alternative and polar questions. *Linguistics and Philosophy* 35(5):361–406.
- Bing, Janet M. 1979. Aspects of English prosody. Ph.D. thesis, University of Massachusetts, Amherst.
- Bobaljik, Jonathan David. 1995. Morphosyntax: The syntax of verbal inflection. Ph.D. thesis, MIT.
- Bobaljik, Jonathan David. 2002. A-chains at the PF-interface: Copies and ‘covert’ movement. *Natural Language & Linguistic Theory* 20:197–267.
- Bobaljik, Jonathan David, and Susi Wurmbrand. 2012. Word Order and Scope: Transparent Interfaces and the $\frac{3}{4}$ Signature. *Linguistic Inquiry* 43(3):371–421.
- Bolinger, Dwight. 1978. Yes-No Questions are not Alternative Questions. In *Questions*, ed. Henry Hiz, 87–105. Dordrecht: D. Reidel.
- Bošković, Željko. 2001. *On the Nature of the Syntax-Phonology Interface: Cliticization and Related Phenomena*. Elsevier.
- Brasoveanu, Adrian. 2007. Structured Nominal and Modal Reference. Ph.D. thesis, Rutgers University.
- Broderick, Kimberley. 1996. The role of prosody in wh-movement: Intonational phrasing and adjunct construal. Ms. University of Massachusetts, Amherst.
- Büring, Daniel. 1997a. The Great Scope Inversion Conspiracy. *Linguistics and Philosophy* 20(2):175–194.
- Büring, Daniel. 1997b. *The Meaning of Topic and Focus: The 59th Street Bridge Accent*. London: Routledge.
- Büring, Daniel. 1999. Topic. In *Focus: Linguistic, Cognitive, and Computational Perspectives*, ed. Peter Bosch and Rob A. van der Sandt, 142–165. Cambridge University Press.
- Büring, Daniel. 2003. On D-trees, Beans, and B-accent. *Linguistics and Philosophy* 26(5):511–545.
- Büring, Daniel. 2006. Focus projection and default prominence. In Molnár and Winkler (2006), 373–397.

- Büring, Daniel. 2012. What's New (and What's Given) in the Theory of Focus? In *Proceedings of the Thirty-Fourth Annual Meeting of the Berkeley Linguistics Society*, ed. Sarah Berson, Alex Bratkievich, Daniel Bruhn, Ramon Escamilla Amy Campbell, Allegra Giovine, Lindsey Newbold, Marilola Perez, Marta Piqueras-Brunet, and Russell Rhomieux, 403–424. Berkeley, CA: Berkeley Linguistics Society.
- Cable, Seth. 2007. The grammar of Q: Q-particles and the nature of Wh-fronting, as revealed by the Wh-questions of Tlingit. Ph.D. thesis, MIT.
- Carlson, Lauri. 1982. Dialogue Games: An Approach to Discourse Analysis. Ph.D. thesis, MIT.
- Carlson, Lauri. 1984. Focus and Dialogue Games. In *Cognitive Constraints on Communication: Representations and Processes*, ed. Lucia Vaina and Jaakko Hintikka, 295–333. Springer.
- Chafe, Wallace L. 1974. Language and Consciousness. *Language* 50(1):111–133.
- Chafe, Wallace L. 1976. Givenness, contrastiveness, definiteness, subjects, topics, and points of view. In *Subject and Topic*, ed. Charles N. Li, 25–56. New York: Academic Press.
- Chan, Marjorie K. M. 1980. Temporal Reference in Mandarin Chinese: An Analytical-Semantic Approach to the Study of the Morphemes *le*, *zai*, *zhe*, and *ne*. *Journal of the Chinese Language Teachers Association* 15(3):33–79.
- Chao, Yuen Ren. 1968. *A Grammar of Spoken Chinese*. Berkeley: University of California Press.
- Chen, Chung-yu. 1978. Aspectual Features of the Verb and the Relative Positions of the Locatives. *Journal of Chinese Linguistics* 6(1):76–103.
- Cheng, Lisa L.-S. 1991. On the Typology of Wh-questions. Ph.D. thesis, MIT.
- Cheng, Lisa L.-S., C.-T. James Huang, and C.-C. Jane Tang. 1996. Negative particle questions: a dialectal comparison. In *Microparametric Syntax and Dialect Variation*, ed. James R. Black and Virginia Motapanyane, 41–78. John Benjamins.
- Chomsky, Noam. 1969. *Deep Structure, Surface Structure, and Semantic Interpretation*. Indiana University Linguistics Club.
- Chomsky, Noam. 1976. Conditions on rules of grammar. *Linguistic Analysis* 2(4): 303–351.
- Chomsky, Noam. 1993. A minimalist program for linguistic theory. In *The view from Building 20: Essays in linguistics in honor of Sylvain Bromberger*, ed. Kenneth Hale and Samuel Jay Keyser, 1–52. Cambridge, MA: MIT Press.
- Chomsky, Noam, and Howard Lasnik. 1977. Filters and Control. *Linguistic Inquiry* 8:425–504.

- Chu, Chauncey C. 1978. Structure and Pedagogy—A Case Study of the Particles “Zhe” and “Ne”. *Journal of the Chinese Language Teachers Association* 13(2): 158–66.
- Chu, Chauncey C. 1984. Beef it up with *ne*. *Journal of the Chinese Language Teachers Association* 19(3):87–91.
- Chu, Chauncey C. 1985a. How would you like your *ne* cooked? *Journal of the Chinese Language Teachers Association* 20:71–78.
- Chu, Chauncey C. 1985b. Pragmatics and teaching of Chinese. In *Proceedings of the First International Conference on Teaching Chinese as a Foreign/Second Language*, ed. Tsung and Tang. Taipei: World Chinese Language Association.
- Chu, Chauncey C. 1998. *A Discourse Grammar of Mandarin Chinese*. Peter Lang.
- Chu, Chauncey C. 2003. Please, Let Topic and Focus Coexist Peacefully! In *Huàtí yǔ jiāodiǎn xīn lùn [New Perspectives on Topic and Focus]*, ed. Liejiong Xu and Danqing Liu, 260–280. Shanghai: Shànghǎi Jiàoyù Chūbǎnshè [Shanghai Education Press].
- Chu, Chauncey C. 2006. A Contrastive Approach to Discourse Particles—A Case Study of the Mandarin UFP Ne. *Wàiguóyǔ (Shànghǎi Wàiguóyǔ Dàxué Xuébào) [Journal of Foreign Languages = Journal of the Shanghai Foreign Language University]* (3):9–31.
- Comorovski, Ileana. 1996. *Interrogative phrases and the syntax-semantics interface*. Dordrecht: Kluwer.
- Constant, Noah. 2009. Contrastive Topic in Dholuo. Ms. University of Massachusetts, Amherst.
- Constant, Noah. 2011. On the Independence of Mandarin Aspectual and Contrastive Sentence-Final *ne*. In *Proceedings of the 23rd North American Conference on Chinese Linguistics (NACCL-23)*, ed. Zhuo Jing-Schmidt, vol. 2, 15–29. University of Oregon, Eugene.
- Constant, Noah. 2012a. English Rise-Fall-Rise: A study in the Semantics and Pragmatics of Intonation. *Linguistics and Philosophy* 35(5):407–442.
- Constant, Noah. 2012b. Topic Abstraction as the Source for Nested Alternatives: A Conservative Semantics for Contrastive Topic. In *Proceedings of West Coast Conference on Formal Linguistics (WCCFL) 30*, ed. Nathan Arnett and Ryan Bennett, 120–130. Cascadia Press.
- Constant, Noah. 2012c. Witnessable Quantifiers License Type-e Meaning: Evidence from CT, Equatives and Supplements. In *Proceedings of Semantics and Linguistic Theory (SALT) 22*, ed. Anca Chereches, 286–306.

- Constant, Noah, Christopher Davis, Christopher Potts, and Florian Schwarz. 2009. UMass Amherst Linguistics Sentiment Corpora. <http://semanticsarchive.net/Archive/jQ0ZGZiM/readme.html>.
- Constant, Noah, and Chloe Chenjie Gu. 2010. Mandarin ‘even’, ‘all’ and the Trigger of Focus Movement. *University of Pennsylvania Working Papers in Linguistics* 16(1):21–30.
- Corblin, Francis. 2007. Existence, Maximality, and the Semantics of Numeral Modifiers. In *Existence: Semantics and Syntax*, ed. Ileana Comorovski and Klaus von Heusinger, vol. 84 of *Studies in Linguistics and Philosophy*, 223–252. Springer.
- Davis, Christopher. 2010. Scope and Prosody in the Japanese Contrastive Topic Construction. Presented at Workshop on Prosody, Syntax and Information IV, Delaware. http://christopher-davis.net/research/talks/wpsi_slides.pdf.
- Dayal, Veneeta. 1996. *Locality in WH Quantification: Questions and Relative Clauses in Hindi*. Studies in Linguistics and Philosophy, Kluwer Academic Publishers.
- DeFrancis, John. 2003. *ABC Chinese-English Comprehensive Dictionary*. University of Hawaii Press.
- Del Gobbo, Francesca. 2003. Appositives at the Interface. Ph.D. thesis, University of California, Irvine.
- Drubig, Hans Bernhard. 1994. Island constraints and the syntactic nature of focus and association with focus. In *Arbeitspapiere des Sonderforschungsbereichs 340: Sprachtheoretische Grundlagen der Computerlinguistik*, vol. 51. Tübingen: University of Tübingen.
- Dryer, Matthew S. 2013. Polar Questions. In *The World Atlas of Language Structures Online*, ed. Matthew S. Dryer and Martin Haspelmath. Leipzig: Max Planck Institute for Evolutionary Anthropology. <http://wals.info/chapter/116>.
- É. Kiss, Katalin. 1993. Wh-movement and specificity. *Natural Language & Linguistic Theory* 11(1):85–120.
- É. Kiss, Katalin. 2007. Topic and Focus: Two Structural Positions Associated with Logical Functions in the Left Periphery of the Hungarian Sentence. In *The Notions of Information Structure*, ed. Caroline Féry, Gisbert Fanselow, and Manfred Krifka, 69–81. Working Papers of the SFB632, Interdisciplinary Studies on Information Structure (ISIS) 6, Potsdam: Universitätsverlag Potsdam.
- Elfner, Emily. 2012. Syntax-Prosody Interactions in Irish. Ph.D. thesis, University of Massachusetts, Amherst.
- Emonds, Joseph. 1979. Appositive Relatives Have No Properties. *Linguistic Inquiry* 10(2):211–243.

- Endriss, Cornelia. 2009. *Quantificational Topics: A Scopal Treatment of Exceptional Wide Scope Phenomena*, vol. 86 of *Studies in Linguistics and Philosophy*. Springer.
- Engdahl, Elisabet. 1980. The Syntax and Semantics of Questions in Swedish. Ph.D. thesis, University of Massachusetts, Amherst.
- Epstein, Samuel David. 1992. Derivational Constraints on \bar{A} -Chain Formation. *Linguistic Inquiry* 23(2):235–259.
- Ernst, Thomas. 1995. Negation in Mandarin Chinese. *Natural Language & Linguistic Theory* 13(4):665–707.
- Evans, Gareth. 1980. Pronouns. *Linguistic Inquiry* 11(2):337–362.
- Fang, Mei. 1994. Běijīnghuà jùzhōng yǔqì cí de gōngnéng yánjiū [A functional study of utterance-internal particles in Beijing dialect]. *Zhōngguó Yǔwén [Chinese Language]* 2:129–138.
- Féry, Caroline. 2007. The prosody of topicalization. In *On Information Structure, Meaning and Form: Generalizations Across Languages*, ed. Kerstin Schwabe and Susanne Winkler, 69–86. John Benjamins.
- Féry, Caroline, and Vieri Samek-Lodovici. 2006. Focus projection and prosodic prominence in nested foci. *Language* 82(1):131–150.
- Fiengo, Robert, and William McClure. 2002. On How to Use -*Wa*. *Journal of East Asian Linguistics* 11(1):5–41.
- von Fintel, Kai. 1994. Restrictions on Quantifier Domains. Ph.D. thesis, University of Massachusetts, Amherst.
- Fodor, Janet Dean, and Ivan A. Sag. 1982. Referential and quantificational indefinites. *Linguistics and Philosophy* 5(3):355–398.
- Fox, Danny. 1999. Reconstruction, Binding Theory, and the Interpretation of Chains. *Linguistic Inquiry* 30(2):157–196.
- Frascarelli, Mara, and Roland Hinterhölzl. 2007. Types of topics in German and Italian. In *On Information Structure, Meaning and Form: Generalizations Across Languages*, ed. Kerstin Schwabe and Susanne Winkler, 87–116. John Benjamins.
- Frege, Gottlob. 1879. *Begriffsschrift: Eine der mathematischen nachgebildete Formelsprache des reinen Denkens*. Halle.
- Gasde, Horst-Dieter. 2004. Yes/no questions and A-not-A questions in Chinese revisited. *Linguistics* 42(2):293–326.
- Geurts, Bart. 2000. Indefinites and Choice Functions. *Linguistic Inquiry* 31(4):731–738.

- Geurts, Bart. 2010. Specific indefinites, presupposition, and scope. In *Presuppositions and Discourse: Essays Offered to Hans Kamp*, ed. Rainer Bäuerle, Uwe Reyle, and Thomas E. Zimmermann, vol. 21 of *Current Research in the Semantics/Pragmatics Interface*, 125–158. Emerald Group.
- Geurts, Bart, and Rick Nouwen. 2007. *At least et al.*: The semantic of scalar modifiers. *Language* 83(3):533–559.
- Grabe, Esther, Greg Kochanski, and John Coleman. 2005. The Intonation of Native Accent Varieties in the British Isles: Potential for Miscommunication? In *English Pronunciation Models: A Changing Scene*, ed. Katarzyna Dziubalska-Kołaczyk and Joanna Przedlacka, 311–337. Bern: Peter Lang.
- Gregory, Michelle L., and Laura A. Michaelis. 2001. Topicalization and Left-Dislocation: A Functional Opposition Revisited. *Journal of Pragmatics* 33(11): 1665–1706.
- Grimshaw, Jane. 1997. Projection, Heads, and Optimality. *Linguistic Inquiry* 28(3): 373–422.
- Groenendijk, Jeroen, and Martin Stokhof. 1984. Studies on the Semantics of Questions and the Pragmatics of Answers. Ph.D. thesis, University of Amsterdam.
- Gundel, Jeanette K. 1974. The Role of Topic and Comment in Linguistic Theory. Ph.D. thesis, University of Texas, Austin.
- Gundel, Jeanette K. 1985. ‘Shared knowledge’ and topicality. *Journal of Pragmatics* 9(1):83–107.
- Gunlogson, Christine. 2008. A question of commitment. In *Commitment*, ed. Philippe De Brabanter and Patrick Dendale, 101–136. John Benjamins Publishing Company.
- Gussenhoven, Carlos. 1984. *On the Grammar and Semantics of Sentence Accents*. Dordrecht: Foris.
- Gutiérrez-Bravo, Rodrigo. 2011. External and Internal Topics in Yucatec Mayan. In *Representing Language: Linguistic Essays in Honour of Judith Aissen*, ed. Rodrigo Gutiérrez-Bravo, Line Mikkelsen, and Eric Potsdam, 105–119. University of California, Santa Cruz: Linguistics Research Center.
- Gyuris, Beáta. 2002. The Semantics of Contrastive Topics in Hungarian. Ph.D. thesis, Eötvös Loránd University, Budapest.
- Gyuris, Beáta. 2008. Rethinking the narrow scope reading of contrastive topic. In *Dislocated Elements in Discourse: Syntactic, Semantic and Pragmatic Perspectives*, ed. Benjamin Shaer, Philippa Cook, Werner Frey, and Claudia Maienborn, 284–311. New York: Routledge.

- Gyuris, Beáta. 2009. Quantificational contrastive topics with verum/falsum focus. *Lingua* 119(4):625–649.
- Gyuris, Beáta. 2012. The information structure of Hungarian. In *The Expression of Information Structure*, ed. Manfred Krifka and Renate Musan, 159–186. Walter de Gruyter.
- Haegeman, Liliane. 2006. Argument Fronting in English, Romance CLLD, and the Left Periphery. In *Crosslinguistic Research in Syntax and Semantics: Negation, Tense, and Clausal Architecture*, ed. Raffaella Zanuttini, Héctor Campos, Elena Herburger, and Paul Portner, 27–52. Georgetown University Press.
- Hagstrom, Paul A. 1998. Decomposing Questions. Ph.D. thesis, MIT.
- Hagstrom, Paul A. 2006. A-not-A Questions. In *The Blackwell Companion to Syntax*, ed. Martin Everaert and Henk C. van Riemsdijk, vol. 1, 173–213. Wiley-Blackwell.
- Hagstrom, Paul A., Joan Chen-Main, Géraldine Legendre, and Liang Tao. 2001. Default *ne* in Child Mandarin Chinese. *Journal of Cognitive Science* 2(2):81–118.
- Haiman, John. 1978. Conditionals Are Topics. *Language* 54(3):564–589.
- Hamblin, Charles Leonard. 1973. Questions in Montague English. *Foundations of Language* 10(1):41–53.
- Han, Chung-hye, and Maribel Romero. 2004. The Syntax Of *Whether/Q... Or* Questions: Ellipsis Combined With Movement. *Natural Language & Linguistic Theory* 22(3):527–564.
- Hara, Yurie. 2006. Grammar of Knowledge Representation: Japanese Discourse Items at Interfaces. Ph.D. thesis, University of Delaware.
- Hedberg, Nancy, and Juan M. Sosa. 2008. The Prosody of Topic and Focus in Spontaneous English Dialogue. In *Topic and Focus: Cross-linguistic Perspectives on Meaning and Intonation*, ed. Chungmin Lee, Matthew Gordon, and Daniel Büring, vol. 82 of *Studies in Linguistics and Philosophy*, 101–120. Springer.
- Heim, Irene. 1982. The Semantics of Definite and Indefinite Noun Phrases. Ph.D. thesis, University of Massachusetts, Amherst.
- Heim, Irene. 1990. E-Type Pronouns and Donkey Anaphora. *Linguistics and Philosophy* 13(2):137–177.
- Heim, Irene, and Angelika Kratzer. 1998. *Semantics in Generative Grammar*. Blackwell.
- Heycock, Caroline. 2008. Japanese *-wa*, *-ga*, and Information Structure. In *The Oxford Handbook of Japanese Linguistics*, ed. Shigeru Miyagawa and Mamoru Saito, 54–83. Oxford University Press.

- Heycock, Caroline, and Anthony Kroch. 1999. Pseudocleft Connectedness: Implications for the LF Interface Level. *Linguistic Inquiry* 30(3):365–397.
- Hirotsu, Masako. 2005. Prosody and LF interpretation: Processing Japanese wh-questions. Ph.D. thesis, University of Massachusetts, Amherst.
- Hirschberg, Julia, and Gregory Ward. 1992. The influence of pitch range, duration, amplitude and spectral features on the interpretation of the rise-fall-rise intonation contour in English. *Journal of Phonetics* 20(2):241–251.
- Horn, Laurence R. 1985. Metalinguistic Negation and Pragmatic Ambiguity. *Language* 61(1):121–174.
- Hou, Xuechao. 1998. *Xiàndài Hànyǔ Xūcí Cídiǎn [A Dictionary of Modern Chinese Function Words]*. Peking University Press.
- Hsieh, Miao-Ling. 2001. Form and Meaning: Negation and Question in Chinese. Ph.D. thesis, University of Southern California.
- Hu, Mingyang. 1981. Běijīnghuà de yǔqì zhùcí hé tàncí [Mood helping-words and interjections in Beijing dialect]. *Zhōngguó Yǔwén [Chinese Language]* (5,6):347–350, 416–423.
- Huang, C.-T. James. 1982a. Logical Relations in Chinese and the Theory of Grammar. Ph.D. thesis, MIT.
- Huang, C.-T. James. 1982b. Move WH in a language without WH movement. *The Linguistic Review* 1:369–416.
- Huang, C.-T. James. 1991. Modularity and Chinese A-not-A Questions. In *Interdisciplinary Approaches to Linguistics: Essays in Honor of Yuki Kuroda*, ed. Carol Georgopoulos and Roberta Ishihara, 305–332. Kluwer Academic Publishers.
- Huang, C.-T. James, Y.-H. Audrey Li, and Yafei Li. 2009. *The Syntax of Chinese*. Cambridge University Press.
- Huang, C.-T. James, and Masao Ochi. 2004. Syntax of the Hell: Two Types of Dependencies. In *Proceedings of North East Linguistic Society (NELS)*, ed. Keir Moulton and Matthew Wolf, vol. 34, 279–293. University of Massachusetts, Amherst: Graduate Linguistics Student Association (GLSA).
- Hyman, Larry M. 1990. Boundary Tonology and the Prosodic Hierarchy. In *The Phonology-Syntax Connection*, ed. Sharon Inkelas and Draga Zec, 109–126. University of Chicago Press and Stanford Center for the Study of Language and Information (CSLI).
- Iatridou, Sabine. 1991. Topics in Conditionals. Ph.D. thesis, MIT.
- Inkelas, Sharon. 1991. *Prosodic Constituency in the Lexicon*. Outstanding Dissertations in Linguistics, Garland.

- Isaacs, James, and Kyle Rawlins. 2008. Conditional Questions. *Journal of Semantics* 25(3):269–319.
- Ito, Junko, and Armin Mester. 2007. Categories and Projections in Prosodic Structure. Presented at Old World Conference in Phonology (OCP) 4: Rhodes, Greece.
- Ito, Junko, and Armin Mester. 2013. Prosodic subcategories in Japanese. *Lingua* 124:20–40.
- Jackendoff, Ray S. 1972. *Semantic Interpretation in Generative Grammar*. Cambridge, MA: MIT Press.
- Jaeger, Florian T. 2004. Topicality and Superiority in Bulgarian Wh-questions. In *Formal Approaches to Slavic Linguistics (FASL) 12*, ed. Olga Arnaudova, Wayles Browne, María Luisa Rivero, and Danijela Stojanović, 207–228. Ann Arbor, MI: Michigan Slavic Publications.
- Jin, Lixin. 1996. Guānyú yíwènjù zhōng de ‘ne’ [On ‘ne’ in Interrogatives]. *Yǔyán Jiàoxué yǔ Yánjiū [Language Teaching and Linguistic Studies]* (4):104–109.
- Kadmon, Nirit. 1987. On Unique and Non-Unique Reference and Asymmetric Quantification. Ph.D. thesis, University of Massachusetts, Amherst.
- Kadmon, Nirit. 2009. Contrastive Topics and the Focal Structure of Questions. Ms. Tel Aviv.
- Kamali, Beste, and Daniel Büring. 2011. Topics in Questions. Presented at GLOW 34, Vienna.
- Kamp, Hans. 1971. Formal Properties of ‘now’. *Theoria* 37:227–273.
- Kamp, Hans. 1981. A Theory of Truth and Semantic Representation. In *Formal Methods in the Study of Language, Part 1*, ed. Jeroen Groenendijk, Theo Janssen, and Martin Stokhof. University of Amsterdam: Mathematische Centrum.
- Kamp, Hans, and Uwe Reyle. 1993. *From Discourse to Logic: Introduction to Model-theoretic Semantics of Natural Language, Formal Logic and Discourse Representation Theory*, vol. 42. Dordrecht: Kluwer Academic.
- Karttunen, Lauri. 1969. Discourse referents. In *Proceedings of the 1969 Conference on Computational Linguistics*, 1–38. Association for Computational Linguistics.
- Katz, Jerrold J., and Paul M. Postal. 1964. *An Integrated Theory of Linguistic Descriptions*. Cambridge, MA: MIT Press.
- Katz, Jonah, and Elisabeth Selkirk. 2011. Contrastive Focus vs. Discourse-New: Evidence from Phonetic Prominence in English. *Language* 87(4):771–816.
- Kennedy, Christopher, and Louise McNally. 2005. Scale Structure, Degree Modification, and the Semantics of Gradable Predicates. *Language* 81(2):345–381.

- King, Brian. 1986. Ne—A Discourse Approach. *Journal of the Chinese Language Teachers Association* 21(1):21–46.
- Klein, Wolfgang. 1994. *Time in Language*. Psychology Press.
- Kratzer, Angelika. 1991. The Representation of Focus. In *Semantics: An International Handbook of Contemporary Research*, ed. Arnim von Stechow and Dieter Wunderlich, 825–834. Berlin: Walter de Gruyter.
- Kratzer, Angelika. 1998. Scope or Pseudo-Scope: Are there Wide-Scope Indefinites? In *Events in Grammar*, ed. Susan Rothstein, 163–196. Dordrecht: Kluwer.
- Kratzer, Angelika. 2003. A Note on Choice Functions in Context. Ms. University of Massachusetts, Amherst.
- Kratzer, Angelika, and Elisabeth Selkirk. 2007. Phase theory and prosodic spellout: The case of verbs. *The Linguistic Review* 24(2-3):93–135.
- Kratzer, Angelika, and Junko Shimoyama. 2002. Indeterminate Pronouns: The View from Japanese. In *Proceedings of the Third Tokyo Conference on Psycholinguistics*, ed. Yukio Otsu, 1–25. Tokyo: Hituzi Syobo. Longer version: <http://semanticsarchive.net/Archive/WEwNjc4Z/>.
- Krifka, Manfred. 1991. A compositional semantics for multiple focus constructions. In *Proceedings of the First Semantics and Linguistic Theory Conference*, 127–158. Cornell University.
- Krifka, Manfred. 1992. A compositional semantics for multiple focus constructions. In *Informationsstruktur und Grammatik*, ed. Joachim Jacobs, vol. 4 of *Linguistische Berichte*, 17–53. Opladen: Westdeutscher Verlag.
- Krifka, Manfred. 1998. Additive Particles under Stress. In *Proceedings of Semantics and Linguistic Theory (SALT) 8*, ed. Devon Strolovitch and Aaron Lawson, 111–128. Cornell: CLC Publications.
- Krifka, Manfred. 1999. At least some Determiners aren't Determiners. In *The Semantics/Pragmatics Interface from Different Points of View*, ed. Ken Turner, vol. 1 of *Current Research in the Semantics/Pragmatics Interface*, 257–291. Elsevier.
- Krifka, Manfred. 2001. Quantifying into Question Acts. *Natural Language Semantics* 9(1):1–40.
- Krifka, Manfred. 2006. Association with Focus Phrases. In Molnár and Winkler (2006), 105–136.
- Krifka, Manfred. 2007. Basic Notions of Information Structure. In *Working Papers of the SFB632, Interdisciplinary Studies on Information Structure (ISIS) 6*, ed. Caroline Féry, Gibsert Fanselow, and Manfred Krifka, 13–55. Potsdam: Universitätsverlag Potsdam.

- Krifka, Manfred. 2013. Negation and Focus in Polarity Questions. Handout for April 12 talk at Harvard University.
- Krifka, Manfred. to appear. Negated Polarity Questions as Denegations of Assertions. In *Contrastiveness and Scalar Implicatures*, ed. Ferenc Kiefer and Chungmin Lee. Springer.
- Kripke, Saul. 1959. A Completeness Theorem in Modal Logic. *Journal of Symbolic Logic* 24:1–14.
- Kripke, Saul. 1963. Semantical Analysis of Modal Logic I: Normal Modal Propositional Calculi. *Zeitschrift für mathematische Logik und Grundlagen der Mathematik* 9:67–96.
- Kuno, Susumu. 1973. *The Structure of the Japanese Language*. Cambridge, MA: MIT Press.
- Kuno, Susumu. 1982. The focus of the question and the focus of the answer. In *Papers from the Parasession on Nondeclarative Sentences*, ed. Robinson Schneider, Kevin Tuite, and Robert Chametzky, 134–157. Chicago Linguistic Society (CLS 18).
- van Kuppevelt, Jan. 1995. Discourse Structure, Topicality and Questioning. *Linguistics* 31(1):109–147.
- van Kuppevelt, Jan. 1996. Inferring from Topics: Scalar Implicatures as Topic-Dependent Inferences. *Linguistics and Philosophy* 19(4):393–443.
- Kuroda, S.-Y. 1972. The Categorical and the Thetic Judgment: Evidence from Japanese Syntax. *Foundations of Language* 9(2):153–185.
- Ladd, D. Robert. 1980. *The Structure of Intonational Meaning: Evidence from English*. Bloomington: Indiana University Press.
- Ladd, D. Robert. 1983. Phonological features of intonational peaks. *Language* 59(4):721–759.
- Ladd, D. Robert. 1984. Declination: A Review and Some Hypotheses. *Phonology Yearbook* 1:53–74.
- Ladd, D. Robert. 1988. Declination “reset” and the hierarchical organization of utterances. *Journal of the Acoustical Society of America* 84(2):530–544.
- Ladd, D. Robert, Ineke Mennen, and Astrid Schepman. 2000. Phonological conditioning of peak alignment in rising pitch accents in Dutch. *Journal of the Acoustical Society of America* 107(5):2685–2696.
- Ladd, D. Robert, Astrid Schepman, Laurence White, Louise May Quarmby, and Rebekah Stackhouse. 2009. Structural and dialectal effects on pitch peak alignment in two varieties of British English. *Journal of Phonetics* 37(2):145–161.

- Ladusaw, William A. 1980. *Polarity Sensitivity as Inherent Scope Relations*. New York: Garland.
- Ladusaw, William A. 1994. Thetic and Categorical, Stage and Individual, Weak and Strong. In *Proceedings of Semantics and Linguistic Theory (SALT) 4*, ed. Mandy HaIvey and Lynn Santelman, 220–229. Ithaca, N.Y.: Cornell University.
- Landau, Idan. 2006. Chain Resolution In Hebrew V(P)-fronting. *Syntax* 9(1):32–66.
- Landau, Idan. 2007. Constraints on Partial VP-fronting. *Syntax* 10(2):127–164.
- Landman, Fred. 1989. Groups, I. *Linguistics and Philosophy* 12(5):559–605.
- Lechner, Winfried. 1998. Two kinds of reconstruction. *Studia Linguistica* 52:276–310.
- Lee, Chungmin. 1999. Contrastive Topic: A Locus of the Interface. In *The Semantics/Pragmatics Interface from Different Points of View*, ed. Ken Turner, vol. 1 of *Current Research in the Semantics/Pragmatics Interface*, 317–341. London: Elsevier.
- Lee, Chungmin. 2003. Contrastive topic and proposition structure. In *Asymmetry in Grammar: Syntax and Semantics*, ed. Anne-Marie Di Sciullo, 345–372. John Benjamins.
- Lee, Chungmin. 2008. Contrastive (predicate) topic, intonation, and scalar meanings. In *Topic and Focus: Cross-Linguistic Perspectives on Meaning and Intonation*, ed. Chungmin Lee, Matthew Gordon, and Daniel Büring, vol. 82 of *Studies in Linguistics and Philosophy*, 151–175. Dordrecht: Springer.
- Lee-Wong, Song Mei. 2001. Coherence, focus and structure: The role of discourse particle Ne. *Pragmatics* 11(2):139–153.
- Legendre, Géraldine. 2000. Morphological and Prosodic Alignment of Bulgarian Clitics. In *Optimality Theory: Phonology, Syntax, and Acquisition*, ed. Joost Dekkers, Frank van der Leeuw, and Jeroen van de Weijer, 423–462. Oxford University Press.
- Lenertová, Denisa. 2001. On clitic placement, topicalization and CP-structure in Czech. In *Current Issues in Slavic Linguistics*, ed. Grit Mehlhorn Gerhild Zybatow, Uwe Junghanns and Luka Szucsich, vol. 5 of *Linguistik International*, 294–305. Berlin: Peter Lang.
- Li, Boya. 2006. Chinese Final Particles and the Syntax of the Periphery. Ph.D. thesis, Leiden University, Netherlands.
- Li, Charles N., and Sandra A. Thompson. 1976. Subject and topic: A new typology of language. In *Subject and Topic*, ed. Charles N. Li, 457–489. New York: Academic Press.

- Li, Charles N., and Sandra A. Thompson. 1979. The Pragmatics of Two Types of Yes-No Questions in Mandarin and its Universal Implications. In *Proceedings of Chicago Linguistic Society (CLS)*, ed. Paul R. Clyne, William F. Hanks, and Carol L. Hofbauer, vol. 15, 197–206.
- Li, Charles N., and Sandra A. Thompson. 1981. *Mandarin Chinese: A Functional Reference Grammar*. Berkeley: University of California Press.
- Li, Daqin. 2001. “WP ne?” wènjù yíwèn gōngnéng de chéngyīn shìxī [An Analysis of the Interrogative Function of “WP ne?”. *Yǔyán Jiàoxué yǔ Yánjiū* [Language Teaching and Linguistic Studies] (6):52–61.
- Li, Shengyu. 2004a. Jiǎshè, tuīcè hé zhēngxún “VP₀ ne?” [Supposition, Conjecture and Consultation of Sentence Pattern “VP₀ ne?”]. *Nèiměnggǔ Shīfàn Dàxué Xuébào* [Journal of Inner Mongolia Normal University] 33(1):88–92.
- Li, Shengyu. 2004b. Ne Zì Yíwènjù Yǎnjiū [A Study of Interrogative Sentences with ‘ne’]. Ph.D. thesis, Central China Normal University, Wuhan.
- Li, Yen-hui Audrey. 1992. Indefinite Wh in Mandarin Chinese. *Journal of East Asian Linguistics* 1(2):125–155.
- Liberman, Mark, and Janet Pierrehumbert. 1984. Intonational Invariance under Changes in Pitch Range and Length. In *Language Sound Structure*, ed. Mark Aronoff and Richard T. Oehrle, 157–233. Cambridge, MA: MIT Press.
- Liberman, Mark, and Ivan Sag. 1974. Prosodic Form and Discourse Function. In *Proceedings of Chicago Linguistic Society (CLS)*, ed. Anthony Bruck, Robert A. Fox, and Michael W. La Galy, 416–427. 10.
- Lin, Jo-wang. 2003. Aspectual selection and negation in Mandarin Chinese. *Linguistics* 41(3):425–459.
- Lin, William C. J. 1984. What does the Mandarin particle NE communicate? *Cahiers de Linguistique - Asie Orientale* 13(2):217–240.
- Link, Godehard. 1983. The Logical Analysis of Plurals and Mass Terms: A Lattice-theoretical Approach. In *Meaning, Use and the Interpretation of Language*, ed. Rainer Bäuerle, Christoph Schwarze, and Arnim von Stechow, 303–23. Walter de Gruyter.
- Manetta, Emily. 2007. Unexpected left dislocation: An English Corpus Study. *Journal of Pragmatics* 39(5):1029–1035.
- Marney, John. 1980. More on “Zhe,” “ne,” and “de”. *Journal of the Chinese Language Teachers Association* 15(2):117–127.
- Matthewson, Lisa. 1999. On the Interpretation of Wide-Scope Indefinites. *Natural Language Semantics* 7:79–134.

- McCarthy, John J. 2006. Prosodic Morphology. In *Encyclopedia of Language & Linguistics*, ed. Keith Brown, 2nd ed., 182–190. Elsevier.
- McCarthy, John J., and Alan Prince. 1995. Faithfulness and Reduplicative Identity. In *University of Massachusetts Occasional Papers in Linguistics 18: Papers in Optimality Theory*, ed. Jill Beckman, Suzanne Urbanczyk, and Laura Walsh Dickey, 249–384. GLSA.
- McCarthy, John J., and Alan S. Prince. 1993. Generalized Alignment. In *Yearbook of Morphology*, ed. Geert Booij and Jaap van Marle, 79–153. Dordrecht: Kluwer.
- McKenzie, Andrew. 2012. The Role of Contextual Restriction in Reference-Tracking. Ph.D. thesis, University of Massachusetts, Amherst.
- McNally, Louise. 1998. On Recent Formal Analyses of Topic. In *The Tbilisi symposium on language, logic, and computation: Selected papers*, 147–160. Stanford, CA: Center for the Study of Language and Information (CSLI).
- Merchant, Jason. 2005. Fragments and ellipsis. *Linguistics and Philosophy* 27(6): 661–738.
- Mikkelsen, Line. 2004. Specifying Who: On the Structure Meaning and Use of Specificational Copular Clauses. Ph.D. thesis, University of California, Santa Cruz.
- Molnár, Valéria, and Susanne Winkler, eds. 2006. *The Architecture of Focus*, vol. 82 of *Studies in Generative Grammar*. Mouton de Gruyter.
- Montague, Richard. 1973. The Proper Treatment of Quantification in Ordinary English. In *Approaches to Natural Language: Proceedings of the 1970 Stanford Workshop on Grammar and Semantics*, ed. K. Jaakko J. Hintikka, Julius M. E. Moravcsik, and Patrick Suppes, 221–42. Dordrecht: D. Reidel.
- Neeleman, Ad, and Hans van de Koot. 2006. Syntactic Haplology. In *The Blackwell Companion to Syntax*, ed. Martin Everaert and Henk van Riemsdijk, vol. IV, chap. 69, 685–710. Wiley-Blackwell.
- Neeleman, Ad, and Reiko Vermeulen. 2012. The Syntactic Expression of Information Structure. In *The Syntax of Topic, Focus, and Contrast: An Interface-based Approach*, ed. Ad Neeleman and Reiko Vermeulen, 1–38. Berlin: Walter de Gruyter.
- Nespor, Marina, and Irene Vogel. 1986. *Prosodic phonology*. Dordrecht: Foris.
- Nouwen, Rick. 2003. Plural Pronominal Anaphora in Context: Dynamic Aspects of Quantification. Ph.D. thesis, University of Utrecht.
- Novel, Marc, and Maribel Romero. 2010. Movement, Variables and Hamblin Alternatives. In *Proceedings of Sinn und Bedeutung 14*, ed. Martin Prinzhorn, Viola Schmitt, and Sarah Zobel, 332–338. Vienna.

- O'Connor, Joseph D., and Gordon F. Arnold. 1973. *Intonation of Colloquial English: A Practical Handbook*. 2nd ed. London: Longman.
- Oshima, David Y. 2005. Morphological vs. phonological contrastive topic marking. In *Proceedings of Chicago Linguistic Society (CLS)*, ed. Rodney L. Edwards, Patrick J. Midtlyng, Colin L. Sprague, and Kjersti G. Stensrud, vol. 41, 371–384.
- Ōta, Tatsuo. 1987. *Zhōngguó Yǔ Lìshǐ Wénfǎ [A Historical Grammar of Modern Chinese]*. Beijing: Běijīng Dàxué Chūbǎnshè [Beijing University Press].
- Pan, Haihua. 1996. Imperfective Aspect *Zhe*, Agent Deletion, and Locative Inversion in Mandarin Chinese. *Natural Language & Linguistic Theory* 14(2):409–432.
- Partee, Barbara H. 1973. Some Structural Analogies between Tenses and Pronouns in English. *Journal of Philosophy* 70(18):601–609.
- Partee, Barbara H. 1987. Noun Phrase Interpretation and Type-shifting Principles. In *Studies in Discourse Representation Theory and the Theory of Generalized Quantifiers*, ed. Jeroen A. G. Groenendijk, Dick De Jongh, and Martin J. B. Stokhof, 115–143. Dordrecht: Foris.
- Paul, Waltraud. to appear. Why particles are not particular: Sentence-final particles in Chinese as heads of a split CP. *Studia Linguistica* 68.
- Peng, Shu-hui, Marjorie K. M. Chan, Chiu-yu Tseng, Tsan Huang, Ok Joo Lee, and Mary E. Beckman. 2006. Towards a Pan-Mandarin System for Prosodic Transcription. In *Prosodic Typology: The Phonology of Intonation and Phrasing*, ed. Sun-Ah Jun, 230–270. Oxford University Press.
- Pierrehumbert, Janet B. 1980. The Phonology and Phonetics of English Intonation. Ph.D. thesis, MIT. Distributed 1988, Indiana University Linguistics Club.
- Pierrehumbert, Janet B., and Julia Hirschberg. 1990. The Meaning of Intonational Contours in the Interpretation of Discourse. In *Intentions in Communication*, ed. Philip R. Cohen, Jerry L. Morgan, and Martha E. Pollack, 271–312. MIT Press.
- Pierrehumbert, Janet B., and Shirley A. Steele. 1989. Categories of Tonal Alignment in English. *Phonetica* 46(4):181–196.
- Pierrehumbert, Janet B., and David Talkin. 1992. Lenition of /h/ and glottal stop. In *Papers in Laboratory Phonology II: Gesture, Segment, Prosody*, ed. Gerard J. Docherty and D. Robert Ladd, 90–117. Cambridge University Press.
- Potts, Christopher. 2002. The Lexical Semantics of Parenthetical-As and Appositive-Which. *Syntax* 5(1):55–88.
- Potts, Christopher. 2005. *The Logic of Conventional Implicatures*. Oxford University Press, USA.

- Prieto, Pilar, Jan van Santen, and Julia Hirschberg. 1995. Tonal alignment patterns in Spanish. *Journal of Phonetics* 23(4):429–451.
- Prince, Alan, and Paul Smolensky. 1993/2002/2004. *Optimality Theory: Constraint Interaction in Generative Grammar*. Blackwell (2004), Technical Report, Rutgers University Center for Cognitive Science and Computer Science Department (2002), Ms. (1993).
- Prince, Ellen. 1998. On the Limits of Syntax, with Reference to Left-Dislocation and Topicalization. In *The Limits of Syntax*, ed. Peter Culicover and Louise McNally, 281–302. Syntax and Semantics 29, New York: Academic Press.
- Prince, Ellen. 1999. How Not to Mark Topics: ‘Topicalization’ in English and Yiddish. In *Proceedings of Spoken and Written Texts Workshop, Texas Linguistic Forum*.
- Pruitt, Kathryn, and Floris Roelofsen. 2011. Disjunctive questions: prosody, syntax, and semantics. Handout for April 12 talk at University of Goettingen.
- Qin, Longlu. 2012. A Conversational Study of the Particle *ne* in Mandarin Chinese. Master’s thesis, University of Alberta, Edmonton.
- Quine, Willard Van Orman. 1963. *Set Theory and Its Logic*. Harvard University Press.
- Radanović-Kocić, Vesna. 1996. The placement of Serbo-Croatian clitics: a prosodic approach. In *Approaching Second: Second Position Critics and Related Phenomena*, ed. Aaron Halpern and Arnold Zwicky, 411–445. Stanford, CA: Center for the Study of Language and Information (CSLI).
- Reichenbach, Hans. 1947. *Elements of Symbolic Logic*. New York: Macmillan Co.
- Reinhart, Tanya. 1981. Pragmatics and Linguistics: An Analysis of Sentence Topics. *Philosophica* 27(1):53–94.
- Reinhart, Tanya. 1997. Quantifier Scope: How Labor Is Divided between QR and Choice Functions. *Linguistics and Philosophy* 20(4):335–397.
- Richards, Norvin. 2000. An Island Effect in Japanese. *Journal of East Asian Linguistics* 9(2):187–205.
- Richards, Norvin. 2010. *Uttering Trees*. Linguistic Inquiry Monograph 56, MIT Press.
- Rietveld, Toni, and Carlos Gussenhoven. 1995. Aligning pitch targets in speech synthesis: effects of syllable structure. *Journal of Phonetics* 23(4):375–385.
- Rizzi, Luigi. 1997. The Fine Structure of the Left Periphery. In *Elements of Grammar: Handbook of Generative Syntax*, ed. Liliane Haegeman, 281–337. Dordrecht: Kluwer.

- Roberts, Craige. 1996. Information Structure in Discourse: Towards an Integrated Formal Theory of Pragmatics. *Ohio State University Working Papers in Linguistics* 49 (Papers in Semantics):91–136.
- Roberts, Craige. 2012a. Information Structure: Afterword. *Semantics and Pragmatics* 5(7):1–19.
- Roberts, Craige. 2012b. Information structure in discourse: Towards an integrated formal theory of pragmatics. *Semantics and Pragmatics* 5(6):1–69.
- Romero, Maribel. 1998. Focus and Reconstruction Effects in Wh-Phrases. Ph.D. thesis, University of Massachusetts, Amherst.
- Ronat, Mitsou. 1984. Logical Form and Prosodic Islands. In *Intonation, Accent and Rhythm: Studies in Discourse Phonology*, ed. Dafydd Gibbon and Helmut Richter, 311–326. Berlin: Walter de Gruyter.
- Rooth, Mats. 1985. Association with Focus. Ph.D. thesis, University of Massachusetts, Amherst.
- Rooth, Mats. 1992. A Theory of Focus Interpretation. *Natural Language Semantics* 1(1):75–116.
- Rooth, Mats. 1996. Focus. In *The Handbook of Contemporary Semantic Theory*, ed. Shalom Lappin, 271–298. London: Blackwell.
- Rooth, Mats. 2005. Topic Accents on Quantifiers. In *Reference and Quantification: The Partee Effect*, ed. Gregory N. Carlson and Francis Jeffrey Pelletier. Stanford, CA: Center for the Study of Language and Information (CSLI).
- Sasse, Hans-Jürgen. 1987. Thethetic/categorical distinction revisited. *Linguistics* 25(3):511–580.
- Sauerland, Uli. 2005. Contrastive Topic: A Reductionist Approach. Presented at Constraints in Discourse. Dortmund University, June 3–5, 2005.
- Schlenker, Philippe. 2011. Donkey anaphora: the view from sign language (ASL and LSF). *Linguistics and Philosophy* 34:341–395.
- Schwarz, Bernhard. 2011. Long Distance Indefinites and Choice Functions. *Language and Linguistic Compass* 5(12):880–897.
- Schwarzschild, Roger. 1996. *Pluralities*. Kluwer Academic Publishers.
- Schwarzschild, Roger. 1999. GIVENness AvoidF and Other Constraints on the Placement of Accent. *Natural Language Semantics* 7(2):141–177.
- Schwarzschild, Roger. 2002. Singleton Indefinites. *Journal of Semantics* 19(3):289–314.

- Selkirk, Elisabeth. 1978/1981. On prosodic structure and its relation to syntactic structure. In *Nordic Prosody II: Papers from a symposium*, ed. Thorstein Fretheim, 111–140. Trondheim: TAPIR.
- Selkirk, Elisabeth. 1984. *Phonology and Syntax: The Relation Between Sound and Structure*. Cambridge, MA: MIT Press.
- Selkirk, Elisabeth. 1986. On derived domains in sentence phonology. In *Phonology Yearbook*, ed. Colin J. Ewen and John Anderson, vol. 3, 371–405. Cambridge University Press.
- Selkirk, Elisabeth. 1995. Sentence Prosody: Intonation, Stress, and Phrasing. In *The Handbook of Phonological Theory*, ed. John A. Goldsmith, chap. 16, 550–569. Cambridge, MA and Oxford, UK: Blackwell.
- Selkirk, Elisabeth. 1996. The Prosodic Structure of Function Words. In *Signal To Syntax: Bootstrapping from Speech to Grammar in Early Acquisition*, ed. James L. Morgan and Katherine Demuth, 187–213. Mahwah, NJ: Lawrence Erlbaum Associates.
- Selkirk, Elisabeth. 2000. The interaction of constraints on prosodic phrasing. In *Prosody: Theory and Experiments*, ed. Merle Horne, vol. 14 of *Text, Speech and Language Technology*, 231–261. Kluwer Academic Publishers.
- Selkirk, Elisabeth. 2002. Contrastive FOCUS vs. presentational focus: Prosodic evidence from right node raising in English. In *Proceedings of the First International Conference on Speech Prosody*, ed. Bernard Bel and Isabelle Marlien, 643–646. Aix-en-Provence: LPL–CNRS / SproSig.
- Selkirk, Elisabeth. 2007. Contrastive Focus, Givenness and the Unmarked Status of “Discourse-New”. In *Working Papers of the SFB632, Interdisciplinary Studies on Information Structure (ISIS) 6*, ed. Caroline Féry, Gibsert Fanselow, and Manfred Krifka, 125–145. Potsdam: Universitätsverlag Potsdam.
- Selkirk, Elisabeth. 2008. Bengali Intonation Revisited: An Optimality Theoretic Analysis in which FOCUS Stress Prominence Drives FOCUS Phrasing. In *Topic and Focus: Cross-Linguistic Perspectives on Meaning and Intonation*, ed. Chungmin Lee, Matthew Gordon, and Daniel Büring, vol. 82 of *Studies in Linguistics and Philosophy*, 215–244. Dordrecht: Springer.
- Selkirk, Elisabeth. 2009. On Clause and Intonational Phrase in Japanese: The Syntactic Grounding of Prosodic Constituent Structure. *Gengo Kenkyu [Linguistic Research]* 136:1–39.
- Selkirk, Elisabeth. 2011a. A syntactic feature [Focus]: The P-side. Presented at GLOW 34.

- Selkirk, Elisabeth. 2011b. The Syntax-Phonology Interface. In *The Handbook of Phonological Theory*, ed. John A. Goldsmith, Jason Riggle, and Alan Yu, 2nd ed., 435–484. Blackwell Handbooks in Linguistics Series, Wiley-Blackwell.
- Sells, Peter. 1985. *Restrictive and Non-Restrictive Modification*. Stanford University: Center for the Study of Language and Information.
- Shan, Chung-chieh. 2004. Binding alongside Hamblin alternatives calls for variable-free semantics. In *Proceedings of Semantics and Linguistic Theory XIV (SALT 14)*, ed. Kazuha Watanabe and Robert B. Young, 289–304. Cornell University Press.
- Shao, Jingmin. 1989. Yǔqìcí ‘ne’ zài yíwènjù zhōng de zuòyòng [The Function of the Expressive Particle ‘ne’ in Interrogatives]. *Zhōngguó Yǔwén [Chinese Language]* (3):170–175.
- Shao, Jingmin. 1996. *Xiàndài Hànyǔ Yíwènjù Yǎnjiū [Research on Interrogatives in Modern Chinese]*. Shanghai: Huádōng Shīfàn Dáxué Chūbǎnshè [East China Normal University Press].
- Shen, Xiao-nan Susan. 1990. *The Prosody of Mandarin Chinese*. Berkeley: University of California Press.
- Shi, Dingxu. 2000. Topic and Topic-Comment Constructions in Mandarin Chinese. *Language* 76(2):383–408.
- Shi, Yu-Zhi. 1997. On the properties of the wh-elements in Chinese. *Journal of Chinese Linguistics* 25(1):131–145.
- Shi, Yu-Zhi, and Ping Zhang. 1995. ‘Ne’ de yǔfǎ yìyì jí yú yíwèn dàicí gòngcún de tiáojiàn. *Journal of the Chinese Language Teachers Association* 30(2):71–84.
- Shie, Chi-chiang. 1991. A discourse-functional analysis of Mandarin sentence-final particles. Master’s thesis, National Chengchi University, Taipei.
- Silverman, Kim, Mary Beckman, John Pitrelli, Mari Ostendorf, Colin Wightman, Patti Price, Janet Pierrehumbert, and Julia Hirschberg. 1992. ToBI: A Standard for Labeling English Prosody. In *Second International Conference on Spoken Language Processing*, vol. 2, 867–870. Banff, Canada.
- Silverman, Kim, and Janet B. Pierrehumbert. 1990. The Timing of Prenuclear High Accents in English. In *Papers in Laboratory Phonology I: Between the Grammar and Physics of Speech*, ed. John Kingston and Mary E. Beckman, 72–106. Cambridge University Press.
- Šimík, Radek. 2010. Interpretation of multiple interrogatives: An information structure sensitive account. In *Formal Approaches to Slavic Linguistics 18: The Second Cornell Meeting 2009*, ed. Wayles Browne, Adam Cooper, Alison Fisher, Esra Kesici, Nikola Predolac, and Draga Zec, 486–501. Ann Arbor, MI: Michigan Slavic Publications.

- Skopeteas, Stavros. 2010. Syntax-Phonology Interface and Clitic Placement in Mayan Languages. In *Movement and Clitics: Adult and Child Grammar*, ed. Vicenç Torrens, Linda Escobar, Anna Gavarró, and Juncal Gutiérrez, 306–331. Cambridge Scholars.
- Smith, Carlota S. 1997. *The Parameter of Aspect*. Dordrecht: Kluwer Academic Publishers.
- Smith, Jennifer L. 2005. On the WH-Question Intonational Domain in Fukuoka Japanese: Some Implications for the Syntax-Prosody Interface. In *University of Massachusetts Occasional Papers in Linguistics (UMOP) 30: Papers on Prosody*, ed. Shigeto Kawahara. Amherst, MA: GLSA.
- Smith, Jennifer L. 2011. [+wh] complementizers drive phonological phrasing in Fukuoka Japanese. *Natural Language & Linguistic Theory* 29:545–559.
- Stalnaker, Robert C. 1978. Assertion. In *Pragmatics*, ed. Peter Cole, 315–332. New York: Academic Press.
- Steedman, Mark. 1991. Structure and Intonation. *Language* 67(2):260–296.
- Steedman, Mark. 2000. Information Structure and the Syntax-Phonology Interface. *Linguistic Inquiry* 31(4):649–689.
- Steedman, Mark. 2008. Information-Structural Semantics for English Intonation. In *Topic and Focus: Cross-Linguistic Perspectives on Meaning and Intonation*, ed. Chungmin Lee, Matthew Gordon, and Daniel Büring, vol. 82 of *Studies in Linguistics and Philosophy*, 245–264. Dordrecht: Springer.
- Steedman, Mark. 2013. The Surface Compositional Semantics of English Intonation. *Language* 89(3).
- Steele, Shirley A. 1986. Nuclear accent *F*₀ peak location: Effects of rate, vowel, and number of following syllables. *Journal of the Acoustical Society of America* 80(S1): S51.
- Stemberger, Joseph Paul. 1981. Morphological Haplology. *Language* 57(4):791–817.
- Sturgeon, Anne. 2006. The Syntax and Pragmatics of Contrastive Topic in Czech. Ph.D. thesis, University of California, Santa Cruz.
- Szabolcsi, Anna. 1995. On Modes of Operation. In *Proceedings of the 10th Amsterdam Colloquium*, ed. Paul Dekker and Martin Stokhof. University of Amsterdam.
- Szabolcsi, Anna. 1997. Strategies for Scope Taking. In *Ways of Scope Taking*, ed. Anna Szabolcsi, 109–154. Dordrecht: Kluwer.
- Szabolcsi, Anna. 2010. *Quantification*. Cambridge University Press.

- Tao, Hongyin. 1996. *Units in Mandarin Conversation: Prosody, Discourse, and Grammar*. John Benjamins Publishing Company.
- Tomioka, Satoshi. 2010a. Contrastive Topics Operate on Speech Acts. In *Information Structure: Theoretical, Typological, and Experimental Perspectives*, ed. Malte Zimmermann and Caroline Féry, 115–138. Oxford University Press.
- Tomioka, Satoshi. 2010b. A Scope Theory of Contrastive Topics. *Iberia* 2(1):113–130.
- Tonhauer, Judith. 2012. Contrastive topics in Paraguayan Guaraní discourse. In *Proceedings of Semantics and Linguistic Theory (SALT) 22*, ed. Anca Chereches, 268–285.
- Truckenbrodt, Hubert. 1995. Phonological Phrases: Their Relation to Syntax, Focus, and Prominence. Ph.D. thesis, MIT.
- Truckenbrodt, Hubert. 1999. On the Relation between Syntactic Phrases and Phonological Phrases. *Linguistic Inquiry* 30(2):219–255.
- Tsao, Feng-fu. 2000. Huáyǔ xūzì de yǎnjiū yǔ jiàoxúe — yǐ ‘ne’ zì wéi lì [Research and Teaching of Chinese “Empty Words” — Taking ‘ne’ as an Example]. In *Dì liù jiè shìjiè huáyǔwén jiàoxúe yǎnjiūhuì lùnwénjí* [Proceedings of the Sixth International Conference on Teaching Chinese as a Foreign Language]. Taipei: Shìjiè Huáyǔwén Jiàoxúe Xúehuì [World Chinese Language Association].
- Tucker, Archibald. 1994. *A Grammar of Kenya Luo (Dholuo)*. Koeln: Ruediger Koepe Verlag.
- Vallduví, Enric, and Elisabet Engdahl. 1996. The linguistic realization of information packaging. *Linguistics* 34(3):459–519.
- Veilleux, Nanette, Stefanie Shattuck-Hufnagel, and Alejna Brugos. 2006. Transcribing Prosodic Structure of Spoken Utterances with ToBI. MIT Lecture Notes (6.911).
- Vendler, Zeno. 1957. Verbs and Times. *The Philosophical Review* 66(2):143–160.
- Vermeulen, Reiko. 2009. Topics, Contrast and Contrastive Topics in Japanese. In *MIT Working Papers in Linguistics 58: Proceedings of the 5th Workshop on Altaic Formal Linguistics (WAFLL 5)*, ed. Reiko Vermeulen and Ryosuke Shibagaki, 361–372.
- Vermeulen, Reiko. 2011. Non-topical *wa*-phrases in Japanese. In *Interfaces in Linguistics: New Research Perspectives*, ed. Raffaella Folli and Christiane Ulbrich, 135–148. Oxford University Press.
- Vermeulen, Reiko. 2012. The information structure of Japanese. In *The Expression of Information Structure*, ed. Manfred Krifka and Renate Musan, 187–216. Walter de Gruyter.

- Vermeulen, Reiko. 2013. On the position of topics in Japanese. *The Linguistic Review* 30(1):117–159.
- Wachowicz, Krystyna. 1974. On the syntax and semantics of multiple questions. Ph.D. thesis, University of Texas, Austin.
- Wagner, Michael. 2006a. Association by movement: evidence from NPI-licensing. *Natural Language Semantics* 14:297–324.
- Wagner, Michael. 2006b. Givenness and Locality. In *Proceedings of Semantics and Linguistic Theory (SALT) 16*, ed. Masayuki Gibson and Jonathan Howell, 295–312. Ithaca, NY: CLC Publications.
- Wagner, Michael. 2009. A Compositional Analysis of Contrastive Topics. In *Proceedings of North East Linguistic Society (NELS)*, ed. Muhammad Abdurrahman, Anisa Schardl, and Martin Walkow, vol. 38, 455–468. University of Ottawa: University of Massachusetts, Amherst: Graduate Linguistics Student Association (GLSA).
- Wagner, Michael. 2012. Contrastive Topics Decomposed. *Semantics and Pragmatics* 5(8):1–54.
- Ward, Gregory, and Julia Hirschberg. 1985. Implicating Uncertainty: The Pragmatics of Fall-Rise Intonation. *Language* 61(4):747–776.
- Watanabe, Akira. 1992. Subjacency and S-structure movement of *wh*-in-situ. *Journal of East Asian Linguistics* 1(3):255–291.
- Werle, Adam. 2009. Word, Phrase, and Clitic Prosody in Bosnian, Serbian, and Croatian. Ph.D. thesis, University of Massachusetts, Amherst.
- Willis, Paul M. 2008. The Role of Topic-Hood in Multiple-Wh Question Semantics. In *Proceedings of the 27th West Coast Conference on Formal Linguistics Poster Session*, ed. Kevin Ryan, 87–95. Cascadilla Press.
- Winter, Yoad. 1997. Choice Functions and the Scopal Semantics of Indefinites. *Linguistics and Philosophy* 20(4):399–467.
- Wold, Dag. 1996. Long Distance Selective Binding: The Case of Focus. In *Proceedings of Semantics and Linguistic Theory (SALT) 6*, ed. Teresa Galloway and Justin Spence, vol. 6, 311–328. Cornell University.
- Wu, Guo. 2005. The Discourse Function of the Chinese Particle *NE* in Statements. *Journal of the Chinese Language Teachers Association* 40(1):47–82.
- Wu, Guo. 2006. “Zhǔwèi wèn”—tán “fēi yíwèn xíngshì + ne” yíwènjù [The “Thematic Question”—On “Non-Interrogative Constituent + ne” Questions]. *Yǔyánxué Lùncóng [Linguistic Forum]* 32:64–82.

- Xiong, Zhongru. 1999. ‘Ne’ zài yíwènjù zhōng de yìyì [The meaning of ‘ne’ in interrogatives]. *Ānhuī Shīfàn Dàxué Xuébào [Journal of Anhui Normal University]* 27(1):114–116.
- Xu, Yi. 1999. Effects of tone and focus on the formation and alignment of f_0 contours. *Journal of Phonetics* 27(1):55–105.
- Xu, Yi. 2004. Transmitting Tone and Intonation Simultaneously—The Parallel Encoding and Target Approximation (PENTA) Model. In *International Symposium on Tonal Aspects of Languages: With Emphasis on Tone Languages*. Beijing.
- Xue, Naiwen, Fei Xia, Fu-Dong Chiou, and Marta Palmer. 2005. The Penn Chinese TreeBank: Phrase Structure Annotation of a Large Corpus. *Natural Language Engineering* 11(2):207–238.
- Yabushita, Katsuhiko. 2008. A New Approach to Contrastive Topic: Partition Semantics and Pragmatics. In *Proceedings of Semantics and Linguistic Theory XVIII (SALT 18)*, ed. Tova Friedman and Satoshi Ito. Cornell University: CLC Publications.
- Yang, Guowen, and John A. Bateman. 2002. The Chinese Aspect System and its Semantic Interpretation. In *Proceedings the 19th International Conference on Computational Linguistics (COLING-2002)*, ed. Shu-Chuan Tseng, vol. 2, 1128–1134. Morgan Kaufmann.
- Ye, Rong. 1994. Guānyú fēi shìfēi wènjù lǐ de “ne” [On “ne” in Non-Yes-No Questions]. *Zhōngguó Yǔwén [Chinese Language]* (6):448–451.
- Yip, Moira. 2002. *Tone*. Cambridge University Press.
- Zec, Draga. 2005. Prosodic differences among function words. *Phonology* 22(1):77–112.
- Zec, Draga, and Sharon Inkelas. 1992. The Place of Clitics in the Prosodic Hierarchy. In *Proceedings of West Coast Conference on Formal Linguistics (WCCFL) 10*, ed. Dawn Bates, 505–519. Stanford, CA: Center for the Study of Language and Information (CSLI).
- Zhang, Bojiang, and Mei Fang. 1996. *Hànyǔ Gōngnéng Yǔfǎ Yánjiū [A study of Chinese Functional Grammar]*. Nánchāng: Jiāngxī Jiàoyù Chūbǎnshè [Jiangxi Education Press].
- Zhang, Ning. 1997. Syntactic Dependencies in Mandarin Chinese. Ph.D. thesis, University of Toronto.
- Zhu, Dexi. 1982. *Yǔfǎ Jiǎngyì [Teaching Materials on Grammar]*. Beijing: Shàngwù Yīnshūguǎn [Trade Printing House].