

# Next generation sequencing analysis of patients with familial cervical artery dissection

Caspar Grond-Ginsbach<sup>1</sup>, Tobias Brandt<sup>2</sup>, Manja Kloss<sup>1</sup>, Suna Su Aksay<sup>1</sup>, Philipp Lyrer<sup>3</sup>, Christopher Traenka<sup>3</sup>, Philipp Erhart<sup>4</sup>, Juan Jose Martin<sup>5</sup>, Ayse Altintas<sup>6</sup>, Aksel Siva<sup>6</sup>, Gabriel R de Freitas<sup>7</sup>, Andreas Thie<sup>8</sup>, Jochen Machetanz<sup>9</sup>, Ralf W Baumgartner<sup>10</sup>, Martin Dichgans<sup>11,12</sup> and Stefan T Engelter<sup>3,13</sup>

European Stroke Journal  
2017, Vol. 2(2) 137–143

© European Stroke Organisation  
2017

Reprints and permissions:  
[sagepub.co.uk/journalsPermissions.nav](http://sagepub.co.uk/journalsPermissions.nav)  
DOI: 10.1177/2396987317693402  
[journals.sagepub.com/home/eso](http://journals.sagepub.com/home/eso)



## Abstract

**Background:** The cause of cervical artery dissection is not well understood. We test the hypothesis that mutations in genes associated with known arterial connective tissue disorders are enriched in patients with familial cervical artery dissection.

**Patients and methods:** Patient duos from nine pedigrees with familial cervical artery dissection were analyzed by whole exome sequencing. Single nucleotide variants in a panel of 11 candidate genes (ACTA2, MYH11, FBNI, TGFBR1, TGFBR2, TGFBR2, COL3A1, COL4A1, SMAD3, MYLK and SLC2A10) were prioritized according to functionality (stop-loss, nonsense, and missense variants with polyphen-2 score  $\geq 0.95$ ). Variants classified as “benign” or “likely benign” in the ClinVar database were excluded from further analysis. For comparison, non-benign stop-loss, nonsense and missense variants with polyphen-2 score  $\geq 0.95$  in the same panel of candidate genes were identified in the European non-Finnish population of the ExAC database ( $n = 33,370$ ).

**Results:** Non-benign Single nucleotide variants in both affected patients were identified in four of the nine cervical artery dissection families (COL3A1; Gly324Ser, FBNI: Arg2554Trp, COL4A1: Pro116Leu, and TGFBR2: Ala292Thr) yielding an allele frequency of 22.2% (4/18). In the comparison group, 1782 variants were present in 33,370 subjects from the ExAC database (allele frequency:  $1782/66,740 = 2.7\%$ ;  $p = 0.0008$ ; odds ratio = 14.2; 95% confidence interval = 3.8–52.9).

**Conclusion:** Cervical artery dissection families showed enrichment for non-benign variants in genes associated with arterial connective tissue disorders. The observation that findings differed across families indicates genetic heterogeneity of familial cervical artery dissection.

## Keywords

Cervical artery dissection, non-benign single nucleotide variants, arterial connective tissue disorder

Date received: 19 September 2016; accepted: 17 January 2017

<sup>1</sup>Department of Neurology, University of Heidelberg, Heidelberg, Germany

<sup>2</sup>Clinics for Neurologic Rehabilitation, Kliniken Schmieder, Heidelberg, Germany

<sup>3</sup>Department of Neurology and Stroke Center, Basel University Hospital, Basel, Switzerland

<sup>4</sup>Department of Vascular and Endovascular Surgery, University Hospital Heidelberg, Germany

<sup>5</sup>Department of Neurology, Sanatorio Allende, Cordoba, Argentina

<sup>6</sup>Neurology Department, Cerrahpasa Medical School, Istanbul University, Turkey

<sup>7</sup>Service of Neurology, Hospital Quinta D’Or/D’Or Institute for Research and Education (IDOR), Rio de Janeiro, Brazil

<sup>8</sup>Klinikum und Seniorenzentrum Itzehoe, Itzehoe, Germany

<sup>9</sup>Städtisches Krankenhaus Dresden-Neustadt, Dresden, Germany

<sup>10</sup>NeuroZentrum, Klinik Hirslanden, Zürich, Switzerland

<sup>11</sup>Institute for Stroke and Dementia Research, Klinikum der Universität München, Ludwig Maximilians Universität, Munich, Germany

<sup>12</sup>Munich Cluster for Systems Neurology (SyNergy), Munich, Germany

<sup>13</sup>Neurorehabilitation Unit, University of Basel and University Center for Medicine of Aging and Rehabilitation, Felix Platter Hospital, Basel, Switzerland

## Corresponding author:

Caspar Grond-Ginsbach, Department of Neurology, University of Heidelberg, INF 400, Heidelberg D-69120, Germany.  
Email: [Caspar.Grond-Ginsbach@med.uni-heidelberg.de](mailto:Caspar.Grond-Ginsbach@med.uni-heidelberg.de)

Spontaneous dissection of the cervical arteries (CeAD) is an important cause of ischemic stroke in younger adults. The detailed causes leading to CeAD are not well understood.<sup>1–3</sup> Major trauma of the neck or head is a rare cause of CeAD, but minor mechanical trigger events were reported in less than half of the patients,<sup>4</sup> which are otherwise healthy individuals typically lacking atherosclerotic vascular risk factors.<sup>4,5</sup> Genetic factors were assumed to modify the risk of occurrence of CeAD.<sup>6</sup> Indeed, carriers of the major allele of a common variant (rs9349379) of the phosphatase and actin regulator 1 encoding gene (PHACTR1) were recently found to have a slightly reduced risk for CeAD.<sup>7</sup> Clinical connective tissue signs and electron microscopic connective tissue alterations were associated with CeAD.<sup>8,9</sup> Nevertheless, known inherited connective tissue disorders seemed exceptional with a frequency of <1% in a recent large series of patients.<sup>10,11</sup> Moreover, mutation search in few candidate genes associated with inherited connective tissue disorders lead to isolated suggestive findings, but was unsuccessful in most patients.<sup>8,12–14</sup> Thus, additional genetic factors modifying the risk for CeAD are yet to be discovered.

In the current study, we assumed that unrecognized manifestations of known inherited connective tissue disorders may predispose to CeAD. To test this assumption, we considered familial CeAD lacking clinically apparent connective tissue disorders as ideal model. On the basis of published genetic studies of arterial connective tissue disorders, we performed a next generation sequencing study and defined a panel of 11 candidate genes which were associated with arterial connective tissue disorders.<sup>15–18</sup> In nine families with familial CeAD, we searched for putative disease-associated, deleterious variants in the predefined panel of candidate genes. Findings were compared with published findings from the European non-Finnish population of the ExAC database (<http://exac.broadinstitute.org/>).<sup>19,20</sup>

## Material and methods

CeAD patients with a family history of CeAD were identified between 2004 and 2015 in databases of neurology departments and stroke centers with a special interest in CeAD.<sup>21–22</sup> All identified families were of German or Swiss–German origin. All affected patients were examined, diagnosed, and treated by stroke neurologists. The diagnosis of CeAD was verified and based on arterial imaging, in particular on magnetic resonance imaging findings.<sup>2</sup> This includes the presence of at least one of the following criteria: mural hematoma, aneurysmal dilatation, long tapering stenosis, intimal flap, double lumen, or occlusion  $\geq 2$  cm above the

carotid bifurcation revealing an aneurysmal dilatation or a long tapering stenosis after recanalization in a cervical artery (i.e. internal carotid artery (ICA) or vertebral artery (VA)). For the current analysis, the following standardized variables were analyzed, applying criteria used in previous publications:<sup>5</sup> age (at onset), sex, site of dissection (ICA or VA), side, type of familial relationship and country of birth.

Peripheral blood was used for DNA extraction. Exome sequencing was performed at the German Research Center for Environmental Health, Helmholtz Zentrum München, on a Genome Analyzer Iix system (Illumina) after in-solution enrichment of exonic sequences (SureSelect Human All Exon 38 Mb kit, Agilent). Read alignment was performed with BWA (version 0.5.8) to the human genome assembly hg19. Single-nucleotide variants (SNVs) were detected with SAMtools (v 0.1.7).

On the basis of published studies,<sup>15–18</sup> we defined a panel of 11 candidate genes (ACTA2, MYH11, FBN1, COL3A1, COL4A1, TGFBR1, TGFBR2, TGFB2, SMAD3, MYLK, SLC2A10) associated with arterial connective tissue disorders (vascular Ehlers-Danlos syndrome, Marfan syndrome, Loeys-Dietz syndrome, familial thoracic aortic aneurysms and dissections, arterial tortuosity syndrome). SNV findings from the CeAD families were prioritized if they (1) had a coverage (depth) of  $\geq 40$  reads; (2) caused nonsense or stop-loss substitutions in the encoded gene product, or missense substitutions with polyphen-2 probability scores  $\geq 0.95$ . In a final filtering step, prioritized missense mutations with polyphen-2 scores  $\geq 0.95$  that were classified as “benign”, “likely benign” or “benign/likely benign”<sup>23</sup> in the ClinVar browser (<https://www.ncbi.nlm.nih.gov/clinvar/>)<sup>24</sup> were removed from subsequent analysis.

Prioritized “non-benign” SNV findings in the CeAD families were compared with reported findings in the European (non-Finnish) populations from the ExAC database (<http://exac.broadinstitute.org/>).<sup>19,20</sup> For each of the 11 arterial connective tissue genes from the candidate panel, all SNVs causing nonsense or stop-loss substitutions or causing missense substitution with polyphen-2 probability score  $\geq 0.95$  and not classified as “benign,” “likely benign,” or “benign/likely benign” in ClinVar were looked up in the ExAC Browser and scored as non-benign variants occurring in the population.

## Results

The study population included nine families with CeAD, each comprising of two family members. In six families, both patients had internal carotid artery dissection (ICAD). Patients from three further families

had dissections in different arterial beds. Multiple or recurrent dissection events were recorded in five families (Table 1). Family trees of the pedigrees are shown in Figure 1. Only relatives with documented presence dissections or with self-reported absence of dissections were represented in the family trees. Genetic testing was performed in affected relatives only.

SNV were considered as deleterious, if they (1) caused a premature stop of the encoded gene product, (2) removed a stop-codon (“stop-loss”) or (3) induced a missense mutation with polyphen-2 probability score  $\geq 0.95$  and with ClinVar classification other than “benign” or “non-benign”. A total of 1242 SNV in the panel of candidate genes were identified in the patient sample, among them 142 SNVs leading to non-sense, stop-loss or missense substitution. Nine missense mutations with polyphen-2 probability score  $\geq 0.95$  were classified as “non-benign”. These non-benign variants in genes associated with arterial connective tissue disorders occurred in four of the nine analyzed CeAD families. These include mutations in COL3A1, FBN1, COL4A1, and TGFBR2, each exclusively in one family. Analysis of copy number variation in the next generation sequencing data did not indicate the occurrence of variants larger than five exons in any of the cases (data not shown).

In detail, two cousins with ICAD from family 604 carried a COL3A1 Gly324Ser substitution which was not found in any control. Both mothers of the patients were asymptomatic carriers of this rare and deleterious SNV. A missense mutation in FBN1 (Arg2554Trp) was identified in a mother and her daughter of family 2149. A Pro116Leu substitution in COL4A1 was identified in family 2953. The father of this family had a dissecting aneurysm of the ICA and multiple aneurysms in other arterial locations. His daughter had an ICAD followed by an asymptomatic contralateral ICAD within four weeks after the first event. The index patient of family 2904 had recurrent ICAD events, whereas her father suffered aortic dissection. Both father and daughter carried a missense mutation (Ala292Thr) in TGFBR2, encoding the transforming growth factor-beta receptor 2. Both patients had hypermobile joints. Moreover, the father showed minor connective tissue signs (Table 2). Finally, one non-benign variant associated with arterial connective tissue disorders (Gly343Arg in FBN1) was found in one affected relative of family 604 (the index-patient, indicated by an arrow in Figure 1), but absent from her affected cousin.

To explore the population frequency of deleterious SNVs in the panel of candidate genes, we analyzed SNV-findings from non-Finnish, European populations from the ExAC database. All subjects with nonsense and stop-loss SNVs as well as all “non-benign” missense substitutions with polyphen-2 probability scores

**Table 1.** The patient population, comprising 18 affected first-degree relatives from nine families.

ID	Index-patient	Related patient	Relationship	Additional affected relative
<i>Familial ICA Dissection</i>				
188	32	F	ICA-le	ICA-bilateral
193	43	M	ICA-le	ICA-le
604	19	F	ICA-ri	ICA-ri
2149	49	F	ICA-le	ICA-ri
2932	45	M	ICA-le	ICA-le
2953	53	M	ICA-le	ICA-ri, ICAD-le
<i>Different vascular systems affected</i>				
15	31	M	ICA-le	VA-le, 4 recurrent CeADs
2889	33	F	ICA-bilateral	VA-ri
2904	20	F	VA-ri, ICAD-ri	Aorta type A
			Sisters	Father with ICAD
			Brother-sister	Sister of index-patient with ICAD
			Cousine-cousine	
			Mother-daughter	
			Brother-sister	
			Father-daughter	
			Father-son	
			Sister-brother	
			Daughter-father	

Note: Numbers indicate years of age at onset of first cervical artery dissection (CeAD) event. Family 2953 was of German-Swiss origin, all other families were from German origin. F: female; M: male; VA: vertebral artery; ICA: internal carotid artery; le: left; ri: right.

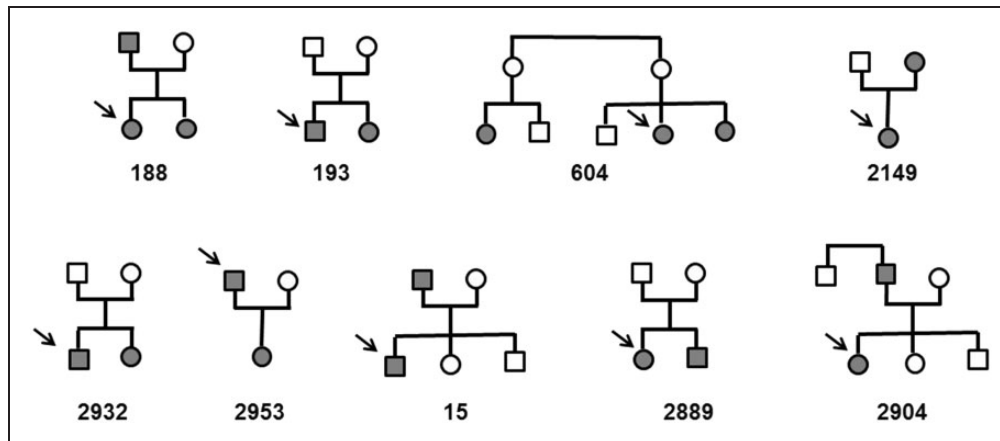

**Figure 1.** Pedigrees of the analysed families. Arrows indicate index-patients (index patients of Table 1). Filled symbols indicate patients with CeAD, open symbols indicate relatives with documented self-reported absence of CeAD. Genetic analysis was performed solely in affected relatives.

**Table 2.** Prioritized non-benign variants in the patient sample.

ID	Gene	Variant	Depth	dbSNP	Polyphen	ClinVar	ExAC allele
604	COL3A1	G324S	135/164	unknown	0.991 (prob. damaging)	Pathogenic	Not found
	FBN1	G343R	77	rs146726731	1.000 (prob. damaging)	Conflicting	13/66,698
2149	FBN1	R2554W	56/93	rs369294972	9.975 (prob. damaging)	Uncertain	2/63,584
2953	COL4A1	P116L	71/75	rs538816765	0.977 (prob. damaging)	No items found	1/66,704
2904	TGFBR2	A292T	150/161	Unknown	1.000 (prob. damaging)	No items found	Not found

Depth: coverage for both affected relatives or (in case of the FBN1 G343R variant) for a single patient; polyphen: polyphen-2 probability score (and assigned classification); prob. damaging: probably damaging; ClinVar: classification of the variant according to the ClinVar database; conflicting: Conflicting interpretations of pathogenicity; uncertain: uncertain significance; ExAC allele frequency: observed allele frequency in the non-Finnish European populations of the ExAC database.

$\geq 0.95$  were counted for each of the 11 genes of the selected panel. The non-Finnish European populations of the ExAC database carried a total of 10,138 SNVs causing nonsense, stop-loss or missense substitutions (Table 3). After removal of SNVs that were classified as “benign” or “likely benign”—including two common variants in the MYLK gene—a total of 1782 non-benign variants was found in the control sample.

The finding of four non-benign SNPs in nine families (allele frequency:  $4/18 = 22.2\%$ ), compared to 1782 findings in 33,370 population controls (allele frequency:  $1782/66,740 = 2.7\%$ ) suggested that carriers with non-benign SNPs in genes associated with arterial connective tissue disorders were at increased risk for familial CeAD (Table 3;  $p = 0.0008$ ; odds ratio = 14.2; 95% confidence interval = 3.8–52.9).

## Discussion

This analysis of rare deleterious SNVs in a predefined set of candidate genes had the following key findings: (1) non-benign variants in genes associated with

inherited arterial connective tissue disorders were observed at low prevalence in the European non-Finnish population, but were about 10 times more frequent in patients with familial CeAD; (2) our study did not identify a single CeAD-specific candidate gene, but observed a polygenic burden of variants across different genes associated with known inherited connective tissue disorders, suggesting genetic heterogeneity of the CeAD phenotype.

Mutations in COL3A1 or TGFBR2 in CeAD patients had been reported in anecdotal case reports,<sup>7,13,14</sup> whereas this had been not the case for FBN1 and COL4A1. The FBN1 Arg2554Trp mutation in pedigree 2149 was described before in three family members with atypical Marfan syndrome affecting the cardiovascular system, but neither the eyes nor the skeleton.<sup>25</sup> Recently, we found this same Arg2544Trp missense mutation of FBN1 in a young woman with multiple CeAD and arachnoidactily (Baumgartner RW and Grond-Ginsbach C, unpublished data). Mutations in COL4A1 were associated with a broad spectrum of symptoms (HANAC (dominant hereditary

**Table 3.** SNVs in the candidate gene panel identified in CeAD patients and in European control subjects.

Gene	Patients (n = 18) All	Patients (n = 18)			Families (n = 9)	Controls (n = 33,370) All	Controls (n = 33,370) Non-benign	p (Fisher's exact test) for comparison of non-benign patients and non-benign controls
		Missense, nonsense, stop-loss	Patients (n = 18) Non-benign					
ACTA2	10	0	0	0	1	1	1.00	
MYH11	231	12	0	0	989	559	0.86	
FBNI	116	23	3	1	290	282	<b>0.038</b>	
TGFBR1	5	2	0	0	19	16	0.99	
TGFBR2	29	2	2	1	167	167	<b>0.044</b>	
TGFB2	7	0	0	0	21	21	0.99	
COL3A1	90	22	2	1	71	71	<b>0.019</b>	
COL4A1	446	34	2	1	410	136	<b>0.036</b>	
SMAD3	73	6	0	0	2	2	1.00	
MYLK	210	39	0	0	8091	450	0.88	
SLC2A10	25	2	0	0	77	77	0.98	
Whole gene panel	1242	142	9	4	10,138	1782	<b>0.0008</b>	

Note: For the patient sample, columns show all identified exome variants (including synonymous variants, splice variants as well as intronic, 3' and 5' UTR variants), all nonsense, stop-loss and missense variants and (third column), nonsense, stop-loss variants as well as missense variants with polyphen-2 probability scores  $\geq 0.95$  and with ClinVar classification other than "benign" or likely "benign". The prioritized variants that were present in both affected relatives of a family were considered as familial. All European non-Finnish carriers of a nonsense or stop-loss variant or of a missense variant with polyphen-2 probability scores  $\geq 0.96$  were counted for each of the 11 candidate genes. In a final prioritization step, variants that were classified as "benign" or "likely benign" were not analyzed further.

angiopathy with nephropathy, aneurysms, and muscle cramps) syndrome), including aneurysms, small vessel disease and hemorrhagic stroke.<sup>26</sup> The affected father of family 2953 developed a large dilatative ICA aneurysm secondary to his ICAD, which may be considered as sign of an underlying syndrome.<sup>18</sup>

No mutations were identified in the remaining four families. Other types of genetic variation may play a role, including small deletions or duplications (indels) causing frame-shift mutations or large structural variant like a deletion covering the whole COL3A1 and COL5A2 genes that was identified in a pilot study of copy number variation (CNV) in CeAD patients.<sup>14</sup> Interestingly, a recent follow-up CNV study in a large patients' sample associated CeAD with genetic variants affecting the development of the vascular system and found such variants in both affected sibs of a family.<sup>27</sup> The lack of findings in five families may also indicate that the current panel of 11 candidate genes was too selective or that the cut-off for the prioritization of variants (with polyphen-2 probability scores  $\geq 0.95$  and with non-benign ClinVar classification) might have been too stringent.

Familial occurrence of CeAD is rare (i.e. <1%).<sup>11,28,29</sup> Hence, the presented sample of nine affected duos with familial CeAD, all white Caucasians from Germany or from the German speaking part of Switzerland, provided a unique material for a genetic analysis. The analysis of a large group of unrelated subjects for the ExAC database for comparison was a

further strength of this study. However, we had no information on age, sex or health state of the analyzed ExAC controls. Nevertheless, our study has several limitations: The study sample of patients was small, which reduced the likelihood of recurrent findings in different families. Moreover, the study sample was highly selective, as most CeAD patients are sporadic (i.e. not familial) and familial occurrence of CeAD is in fact exceptional. Sequence analysis of larger series of patients is therefore needed to estimate the contribution of rare genetic variants in the pathogenesis of sporadic CeAD. The variants in this study were prioritized with regard to functionality, but not with regard to frequency. As all prioritized familial variants appeared to be extremely rare in the non-Finnish European controls, it is tempting to reanalyze the frequency of non-benign variants in the control population after exclusion of common variants. Prioritization of rare variants in the ExAC sample would suggest an even more dramatic enrichment of variants in the familial CeAD patients (data not shown).

## Conclusion

CeAD families showed enrichment for deleterious variants in genes associated with arterial connective tissue disorders. The observation that findings were identical within each family but different across families indicates genetic heterogeneity of CeAD.

## Acknowledgements

The authors thank Werner Hacke for continuous support, Dr Tim Strom for valuable advice, and Inge Werner for excellent technical assistance.

## Declaration of Conflicting Interests

The author(s) declared no potential conflicts of interest with respect to the research, authorship, and/or publication of this article.

## Funding

The author(s) disclosed receipt of the following financial support for the research, authorship, and/or publication of this article: MD received funding from the Vascular Dementia Research Foundation; this research was partly supported by the Basel Stroke Funds and the Neurological Clinic of the University Hospital Basel.

## Ethical approval

The study protocol was approved by relevant local authorities in all participating centers and complied with all national regulations concerning ethics committee approval and informed consent.

## Informed Consent

All patients gave written informed consent prior to study participation

## Guarantor

CG-G.

## Contributorship

CGG, MD, and STE conceived the study. TB, MK, PL, CT, PE, JJM, AA, AS, GRF, AT, JM, and RWB were involved in patient recruitment. CGG, SSA, PE, and STE interpreted the data and wrote the manuscript. All authors reviewed and edited the manuscript and approved the final version.

## References

1. Debette S and Leys D. Cervical-artery dissections: predisposing factors, diagnosis, and outcome. *Lancet Neurol* 2009; 8: 668–678.
2. Engelter ST, Traenka C, Von Hessling A, et al. Diagnosis and treatment of cervical artery dissection. *Neurol Clin* 2015; 33: 421–441.
3. Goeggel Simonetti B, Mono ML, Huynh-Do U, et al. Risk factors, aetiology and outcome of ischaemic stroke in young adults: the Swiss Young Stroke Study (SYSS). *J Neurol* 2015; 262: 2025–2032.
4. Engelter ST, Grond-Ginsbach C, Metso TM, et al. Cervical artery dissection – trauma and other potential mechanical trigger events. *Neurology* 2013; 80: 1950–1957.
5. Debette S, Metso T, Pezzini A, et al. Association of vascular risk factors with cervical artery dissection and ischaemic stroke in young adults. *Circulation* 2011; 123: 1537–1544.
6. Grond-Ginsbach C, Debette S and Pezzini A. Genetic approaches in the study of risk factors for cervical artery dissection. *Front Neurol Neurosci* 2005; 20: 30–43.
7. Debette S, Kamatani Y, Metso TM, et al. Common variation in PHACTR1 is associated with susceptibility to cervical artery dissection. *Nat Genet* 2015; 47: 78–83.
8. Giossi A, Ritelli M, Costa P, et al. Connective tissue anomalies in patients with spontaneous cervical artery dissection. *Neurology* 2014; 83: 2032–2037.
9. Brandt T, Orberk E, Weber R, et al. Pathogenesis of cervical artery dissections: association with connective tissue abnormalities. *Neurology* 2001; 57: 24–30.
10. Grond-Ginsbach C and Debette S. The association of connective tissue disorders with cervical artery dissections. *Curr Mol Med* 2009; 9: 210–214.
11. Debette S, Goeggel Simonetti B, Schilling S, et al. Familial occurrence and heritable connective tissue disorders in cervical artery dissection. *Neurology* 2014; 83: 2023–2031.
12. Kuivaniemi H, Prockop DJ, Wu Y, et al. Exclusion of mutations in the gene for type III collagen (COL3A1) as a common cause of intracranial aneurysms or cervical artery dissections: results from sequence analysis of the coding sequences of type III collagen from 55 unrelated patients. *Neurology* 1993; 43: 2652–2658.
13. Pezzini A, Drera B, Del Zotto E, et al. Mutations in TGFBR2 gene cause spontaneous cervical artery dissection. *J Neurol Neurosurg Psychiatr* 2011; 82: 1372–1374.
14. Grond-Ginsbach C, Chen B, Pjontek R, et al. Copy number variation in patients with cervical artery dissection. *Eur J Hum Genet* 2012; 20: 1295–1299.
15. Milewicz DM, Carlson AA and Regalado ES. Genetic testing in aortic aneurysm disease: PRO. *Cardiol Clin* 2010; 28: 191–197.
16. Plaisier E, Chen Z, Gekeler F, et al. Novel COL4A1 mutations associated with HANAC syndrome: a role for the triple helical CB3[IV] domain. *Am J Med Genet A* 2010; 152A: 2550–2555.
17. Pomianowski P and Elefteriades JA. The genetics and genomics of thoracic aortic disease. *Ann Cardiothorac Surg* 2013; 2: 271–279.
18. Vanakker OM, Hemelsoet D and De Paepe A. Hereditary connective tissue diseases in young adult stroke: a comprehensive synthesis. *Stroke Res Treat* 2011; 2011: 712903.
19. Lek M, Karczewski KJ, Minikel EV, et al. Analysis of protein-coding genetic variation in 60,706 humans. *Nature* 2016; 536: 285–291.
20. Karczewski KJ, Weisburd B, Thomas B, et al. The ExAC browser: displaying reference data information from over 60 000 exomes. *Nucleic Acids Res* 2016 (in press).
21. Martin JJ, Hausser I, Lyrrer P, et al. Familial cervical artery dissections: clinical, morphologic, and genetic studies. *Stroke* 2006; 37: 2924–2929.
22. Grond-Ginsbach C, de Freitas GR, Campos CR, et al. Familial occurrence of cervical artery dissection – Coincidence or sign of familial predisposition? *Cerebrovasc Dis* 2012; 33: 466–470.
23. Richards S, Aziz N, Bale S, et al. Standards and guidelines for the interpretation of sequence variants: a joint

- consensus recommendation of the American College of Medical Genetics and Genomics and the Association for Molecular Pathology. *Genet Med* 2015; 17: 405–424.
24. Landrum MJ, Lee JM, Benson M, et al. ClinVar: public archive of interpretations of clinically relevant variants. *Nucleic Acids Res* 2016; 44: D862–D868.
  25. Comeglio P, Johnson P, Arno G, et al. The importance of mutation detection in Marfan syndrome and Marfan-related disorders: report of 193 FBN1 mutations. *Hum Mutat* 2007; 28: 928.
  26. Meuwissen ME, Halley DJ, Smit LS, et al. The expanding phenotype of COL4A1 and COL4A2 mutations: clinical data on 13 newly identified families and a review of the literature. *Genet Med* 2015; 17: 843–853.
  27. Grond-Ginsbach C, Chen B, Krawczak M, et al. Genetic imbalance in patients with cervical artery dissection. *Current Genomics* 2017; 18: 206–213.
  28. Kloss M, Grond-Ginsbach C, Pezzini A, et al. Stroke in first-degree relatives of patients with cervical artery dissection. *Eur J Neurol* 2014; 21: 1102–1107.
  29. Thijs V, Grittner U, Dichgans M, et al. Family history in young patients with stroke. *Stroke* 2015; 46: 1975–1978.