



**Electrical Engineering Department
California Polytechnic State University**

Senior Project Final Report

Bi-Directional DC-DC Converter

June 2, 2020

Authors

Oscar Ambriz

Luis Onofre

Jack Hamlin

Advisor

Taufik

Table of Contents

List of Figures	3
List of Tables	3
Abstract	4
Chapter 1. Introduction	5
Chapter 2. Background	8
Chapter 3 Design Requirements	11
Chapter 4 Design	13
Chapter 5 Simulation	19
Chapter 6: Conclusion	29
References	32
A Final Schematic	32
B Bill of Materials	34
C Analysis of Senior Project	36

List of Figures

<u>Figure 2-1: DC House system overview</u>	<u>9</u>
Figure 3-1: Level 0 Block Diagram	11
Figure 3-2: Bidirectional DC-DC Converter Level 1 Block Diagram	12
Figure 4-1: Level 2 Diagram	14
Figure 4-2: Circuit Schematic of the Bidirectional Converter	19
Figure 5-1: Simulation Schematic	20
Figure 5-2: Buck Mode Efficiency at different loads	22
Figure 5-3: Buck Mode Output Voltage Full Load	22
Figure 5-4: Buck Mode Critical Waveforms Full Load	23
Figure 5-5: Boost Mode Efficiency at different loads	24
Figure 5-6: Boost Mode Output Voltage Full Load	25
Figure 5-7: Boost Mode Critical Waveforms Full Load	26
Figure 5-8: PCB layout top layer	28

List of Tables

Tables 3-1: DC House EMS Design Requirements and Specifications	13
Table 5-1: Line Regulation Values	26
Table 5-2: Load Regulation Values	27

Abstract

This project was developed with the purpose of creating an efficient energy management system for the DC House project, with a centralized 12V battery system fed by a 48V Multiple Input Single Output Source (MISO). The energy management system will consist of a bidirectional DC-DC converter. During the day when the renewable sources produce enough energy to fulfill the load's energy demand, the converter will make use of the excess energy by taking a 48V DC input and stepping it down to a 12V DC output in order to charge a 12V 100 Ah battery. When renewable sources can no longer supply the energy required by the load the necessary energy will be pulled from the 12V battery. The converter at this time will take the 12V DC input from the battery and step it up to a 48V output connected to DC House load. The proposed design was tested using LTSpice simulation whose results showed that the converter can indeed provide the bi-directional power flow as desired. Due to COVID-19 pandemic, the originally planned hardware construction must be abandoned following campus shut-down and our inability to get access to lab equipment necessary to conduct the hardware development and testing. Simulation results also showed that the proposed design was able to meet the less than 2% line and load regulation requirements. Furthermore, the efficiency of the proposed converter was measured to be around 85% at full load.

Chapter 1. Introduction

In the modern age of technology, electricity is one of the most important sectors in our lives where technological improvements are still needed. At the center of these improvements lies power electronics. Power electronics places an emphasis on efficiency when dealing with the flow of power from the source to the load and vice versa. Prior to power electronics voltage from the wall outlet would primarily be stepped down using a linear setup that operates similarly to a resistor divider network in order to reach a required lower voltage. These linear setups result in very low efficiency due to losses from the series-pass transistor. But now with power electronics, we can make use of switches to turn the flow of power on and off to charge and discharge inductors and capacitors. When the switch is closed, the source both charges the inductor and provides power to the load. When the switch opens, the inductors and capacitors will discharge and provide continuous power to the load. These alternating states allow for a consistent output voltage to be generated while limiting losses such that they are much less than those occurring in the linear electronics. Some examples of areas where power electronics have become a crucial part of the design are in renewable energy, communication devices, computers, data centers, and transportation. The primary goal of power electronics is to suppress power losses when processing the energy while also minimizing design costs, thus improving the efficiency of the devices.

Power electronic designs come in four different categories, AC-DC, DC-AC, AC-AC, and DC-DC. AC-DC converters are referred to as rectifiers. Rectifiers come in two types: uncontrolled and controlled rectifiers. The difference between the two types is that given a fixed input voltage, the uncontrolled rectifier outputs a fixed DC voltage while the controlled type outputs a variable DC voltage. DC-AC converters are referred to as inverters which convert a DC

voltage to a fixed or variable AC voltage and frequency. AC-AC converters come in two forms, AC voltage controllers which convert a fixed AC voltage to a variable AC voltage at the same frequency, and cyclo converters which convert a fixed AC voltage and frequency to a variable AC voltage and frequency. The next type of power electronic converters is the DC-DC converters. These converters convert a DC input voltage to output another DC voltage which could be lower, equal to, or higher than the input voltage. DC-DC converters come in two forms: isolated and non-isolated DC-DC converters, which differ mainly in that isolated converters make use of transformers while non-isolated converters do not.

For most people, the most commonly encountered power electronic converters are AC-DC converters and DC-DC converters. Most common household devices make use of DC power which means that if they are plugged into the wall, an AC-DC converter must be used. Many devices also make use of DC-DC converters to power different components within the device. A common example of this would be a computer since many of the internal components will require different DC voltages to safely power them. The three basic non-isolated DC-DC converters are the buck, boost, and buck-boost converters. A buck converter is a step-down converter, which takes an input voltage and outputs a lower voltage. A boost converter is a step-up converter, which takes an input voltage and outputs a higher voltage. Lastly, a buck-boost can both step up and step down the voltage and additionally inverts the polarity of the voltage level.

Renewable energy is especially dependent on the use of power electronics. For any household usage, such as solar panel roofing, converters are necessary to utilize the power generated. Solar panels generate DC electricity which must then be put through an inverter to convert the electricity into AC power which is the common type of electricity found in a home. High efficiency is necessary to make many renewables cost effective options, especially when

compared to the power provided by the grid. Battery management systems (BMS) are used to provide reliable power from renewable sources at all hours of the day. These systems will store excess electricity and discharge the batteries to the load when electricity is not generated from any one of the sources. As an example, any excess energy generated by solar panels will be stored in the battery system, for use during the evening and nighttime hours when energy is no longer generated. Power electronics makes it possible for this back and forward flow of energy between the sources, the battery, and load to occur efficiently. And the BMS is the component that ensures that the energy flow among the three elements (sources, battery, and load) can be coordinated properly to enhance the reliability of the entire system.

Chapter 2. Background

The DC House Project

The DC House Project is a humanitarian project focused on providing energy to rural or secluded areas through the use of renewables and human powered generators [6][2]. While AC power is the most dominant form of electricity, many rural or secluded areas especially in third world countries do not have reliable access to AC power [3][4]. This issue makes renewable energy sources the more ideal choice for rural electrification. An added benefit of a fully DC house system is that there is not a need for a DC-AC converter or inverter. This results in an increase in efficiency since the DC source can deliver its power to the DC loads through a DC-DC converter instead of going through DC-AC first and then AC-DC stage. A DC House system in general has 3 parts: the multiple input single output (MISO) system, the energy management system (EMS), and the DC House itself as the load. The MISO system allows multiple renewable energy sources to be connected and provides a single output voltage to a DC bus. The EMS system regulates the flow of electricity to charge and discharge the battery as renewable sources are inconsistent. The battery is charged and discharged through a bi-directional DC-DC converter. Figure 2-1 shows the basic diagram of the DC House [1].

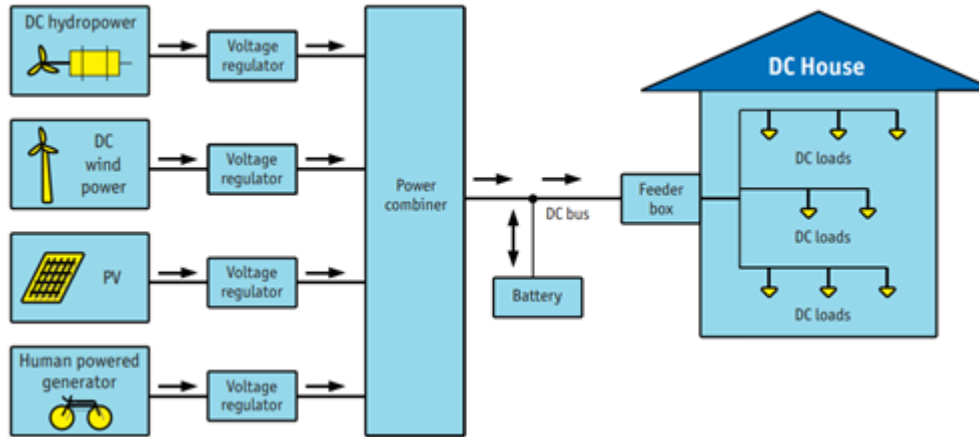

Figure 2-1: DC House system overview [1].

Current Energy Management for the DC House Project

Referring to [5], the current EMS for the DC House uses a 48V bus and a 12V battery. Furthermore, the design tracks the state of charge (SoC) which can also monitor voltage, current, runtime-to-empty, and temperature of the battery. This design is for use with 12V Pb-Acid batteries. Based on the state of charge of the battery and the demand from the load, a microcontroller will direct the flow of electricity to either charge or discharge the battery. This is accomplished by controlling when the DC-DC converter is stepping the voltage down from 48V to 12V (buck mode) or stepping the voltage up from 48V to 12V (boost mode). Operating parameter values are displayed on a small LCD screen. To accommodate the charging and discharging of the battery, a bidirectional DC-DC converter was utilized using the Buck-Boost converter to control the direction of the power [5].

Many design changes can be implemented to improve the overall quality of the current EMS design. Our primary improvement is that the bidirectional converter in this project should operate at a greater efficiency than our predecessors due to advances in bidirectional converter

technology. With the help of a new controller, an efficiency greater than 90% should be achieved compared to the previous design whose efficiency peaked at 88%-90% and decreased significantly as output current decreased. The previous design also noted that the chip used in the design created a number of issues that limited how quickly the LCD screen could be updated and that it was nearing the end of production. A more robust SoC chip would greatly improve the processing speed of the LCD. Another area of improvement is the price point. The DC House project is primarily geared towards humanitarian efforts, a low cost is ideal. The current design has a cost of \$515, primarily due to the cost of the DC-DC converter board at \$370. Finally, while the previous project displays the voltage and current values using the LCD screen, most consumers will not have the knowledge to understand what this means.

The purpose of this project is to design the EMS for the DC House in conjunction with the bi-directional DC-DC converter to improve both efficiency and cost-effectiveness. The system itself will have the same overall functionality as the previous iteration: to safely control the flow of electricity between the bus, the battery, and the DC house. There are several possible approaches to improve the overall design. First is to reduce the overall price of the design to better meet the humanitarian goals of the DC House Project. The second is to implement a see-through case of the converter to better allow the users to view the device and identify any areas of damage due to the high voltage and current. The LCD screen could also be improved to show additional information about the device that is more user friendly such as the overall efficiency of the EMS and the mode of operation.

Chapter 3 Design Requirements

The bidirectional DC-DC converter will be used in the DC house battery management system. This design will be focusing on improving efficiency while keeping the price low. The main connections for the converter are the 48V bus that connects to both the DC house and the renewable source through the MISO. On the other side, it connects to a 12V bus that connects to the Battery System. There are also several connections from different sensors that connect to the microcontroller which controls the flow of the power, this includes a battery change sensor and a signal from the MISO that tells us the available power that is being generated. Figure 3-1 shows the overall inputs and outputs to the DC-DC converter. Additionally, since the converter deals with relatively high voltages, a durable enclosure will be designed for the safety of the user.

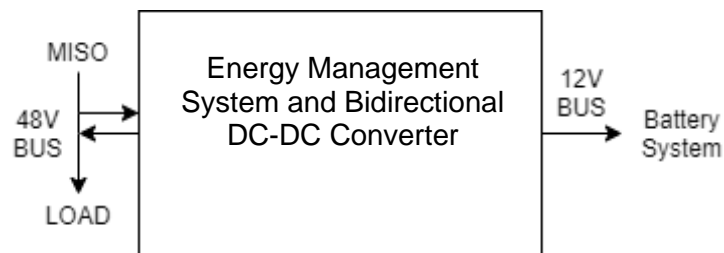

Figure 3-1: Level 0 Block Diagram

The overall system design is shown in the Level 0 Block Diagram. The DC House load will vary based on the power needs within the house. If the renewable energy source provides the necessary power, the EMS system will send the power directly to the load. If the bus does not provide enough power, the Bi-Directional DC-DC converter will be connected, and the battery will provide the power needed. If the Bus provides more power than is needed by the DC house load, the excess power will charge the battery.

Based on this top-level design, more precise design choices can be made. The primary goal of this project is to improve the overall cost and efficiency of the design. A more modern converter chip is being implemented in the Bi-Directional DC-DC converter to improve the overall efficiency.

The state of the converter will be selected through the use of a microcontroller based on the State of Charge of the battery, the load demand, and the power provided from the MISO. The SOC chip is connected to a microcontroller to process the voltage, current, and temperature of the battery. By comparing these values with the voltage and current of the bus, the microcontroller will change the mode of the converter to meet the needs of the house. While the converter has built in sensing to switch between step-down (Buck mode) from 48V to 12V and step-up (Boost mode) from 12V-48V, the microcontroller will be used to switch between Buck and Boost mode so as to protect against overcharging the battery. The microcontroller will also be connected to an LCD screen to display the charge level of the battery, the current mode of operation, and the temperature of the system.

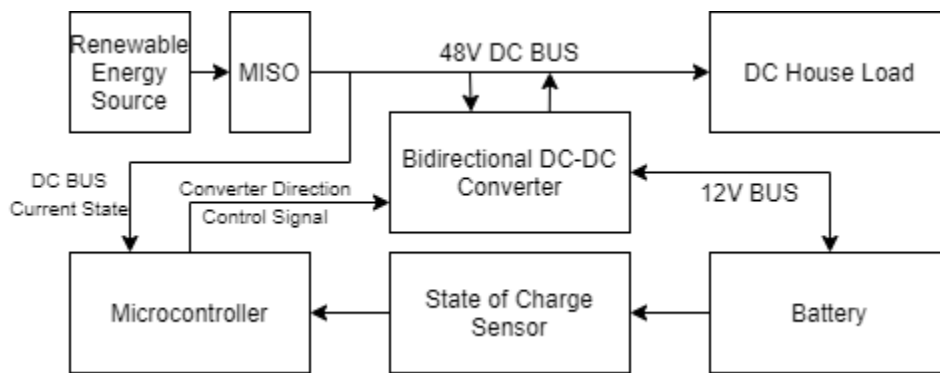

Figure 3-2: Bidirectional DC-DC Converter Level 1 Block Diagram

Table 3-1 provides a summary of the engineering specifications for the Level 0 and Level 1 block diagrams as well as general product design specifications and their justifications.

Table 3-1: DC House EMS Design Requirements and Specifications

Engineering Specifications	Justification
The design should have a single converter rather than 2 converters for the forward and backward conversions	The primary goal of this project is to have bi-directionality implemented
Total Power bank of 100Ah with a 12V battery	The power bank must be able to sustain the house for at least 12 hours without being recharged.
DC Conversion efficiency of > 90%	The previous iteration of this project peaked at roughly 88% efficiency; a 2% increase would be a notable markup.
Line and Load Regulation < 5%	Keeping the line and load regulations low allows for a more robust and reliable system.
The system will change modes in real time to meet the needs of the load.	Energy is wasted if the converter does not switch to the proper mode as quickly as possible, reducing efficiency.
DC-DC converter will convert between 12V and 48V and vice versa.	The bus and load run on 48V while the battery runs on 12V.
The total cost of the system should be < \$200	This is based on the previous project's bill of materials for their final design.
The system will be in a weather-resistant enclosure	This will protect the system from damage from environmental effects.
An LCD screen will be implemented in order to show the current state of the converter.	This will allow the customer to know the current charge status and mode of the converter.
The controller will have overcharge and temperature protection.	Overcharging or overheating can damage the battery bank, rendering it useless.

Chapter 4 Design

Similar to our predecessors, the design of the DC House Energy Management System (EMS) implements a single bi-directional converter. To improve the system, a more recent and

updated controller was selected to improve efficiency and reduce cost. A new state of charge IC was also selected that has similar capabilities to the one used in previous iterations of the project but in a smaller form factor. Figure 4-1 shows a more detailed view of the two designed subsystems working together.

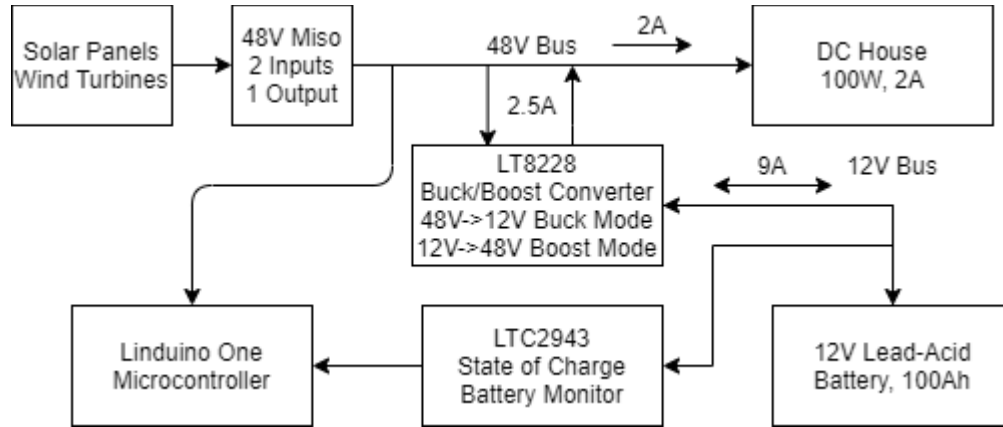

Figure 4-1: Level 2 Diagram

Bidirectional DC-DC Converter

For the bi-directional DC-DC converter, the LT8228 controller is selected due to its bi-directional buck and boost capabilities, wide input-output voltage range and over current protection. The switching frequency is set to be 249kHz by connecting a 38.3kΩ resistor from the RT pin to the ground [7]. Next, the Inductor value is calculated based on a 30% maximum inductor current ripple. The same Inductor is used in the power path in both buck and boost modes. Note for the following calculations the buck input voltage is referred to $V_1 = 48\text{ V}$ and the boost input voltage is referred to $V_2 = 12\text{ V}$:

$$L = \frac{V_2(V_1 - V_2)}{f_{sw} \cdot \Delta i_{out} V_1} = \frac{12(48 - 12)}{249k \cdot 3.85 \cdot 48} = 9.38\mu H$$

The inductor also has to be rated for a peak current of 12.925A due to the 30% current ripple. A 15μH fixed inductor from Würth Elektronik is selected, meeting the minimum inductance value set by the calculated value above along with a current rating of 30A. There are a total of six MOSFETs in the

design. Four MOSFETs (M1A/M1B, and M4A/M4B) are used for input protection and the other two (M2 and M3) are part of the power path. In buck mode, M2 is the main switch and M3 is the synchronous switch. In boost mode, M3 is the main switch and M2 is the synchronous switch. Both sets of protection MOSFETs must be rated to handle 10 V above their respective input voltage as specified by the datasheet and above their respective output current [7].

$$M1_V = 58V \text{ and } M1_I = 2.5A \quad M4_V = 22V \text{ and } M4_I = 11A$$

Both power path MOSFETs (M2 and M3) at a point have the input voltage V_1 across its terminals thus they are both rated to withstand above V_1 . The current ratings are determined by calculating their respective current during both modes of operation.

Buck Mode:

$$I_{o2} = \frac{100 W}{V_2} = 8.333 A$$

$$D = \frac{V_2}{V_1} = 0.25$$

$$I_{M3} = I_{o2} * (1 - D) = 6.25 A$$

$$I_{M2} = I_{o2} * D = 2.083 A$$

Boost Mode:

$$I_{o2} = \frac{100 W}{V_1} = 2.083 A$$

$$D = -\left(\frac{V_2}{V_1} - 1\right) = 0.75$$

$$I_{M3} = \frac{(D * I_{o1})}{(1 - D)} = 6.25 A$$

$$I_{M2} = I_{o1} = 2.083 A$$

M2 and M3 require a current rating of 7.5A and a voltage rating of 48V. The N-channel MOSFET BSC097N06NSATMA1 from Infineon Technologies was selected for all six MOSFETs since it meets the minimum requirements calculated above with a voltage rating of 60V and a current rating of 46A. Sensing resistors for both V_1 and V_2 are calculated assuming peak inductor current and a voltage drop between 50mV to 200mV. The duty cycle of our

converter is set to the appropriate value with the two sensing resistors. The calculations for both sensing resistors are as follows:

$$R_{sns1} = \frac{50mV}{I_{1Limit}} = \frac{50mV}{15.639A} = 3m\Omega \quad R_{sns2} = \frac{50mV}{I_{2Limit}} = \frac{50mV}{11A} = 5m\Omega$$

Susumu sensing resistors with the respective values were selected with a power rating of 3W.

Notice that in both cases the inductor current is limited to a fixed value. In the case of R_{sns1} we have 2.5A and for R_{sns2} we have 9 A. The inductor current limit is set using the R_{in} resistors.

$$R_{in1} = \frac{ILmax * Rsns1}{72.5\mu A} = \frac{15.639A * 3m\Omega}{72.5\mu A} = 689\Omega$$

$$R_{in2} = \frac{ILmax * Rsns2}{72.5\mu A} = \frac{15.639A * 5m\Omega}{72.5\mu A} = 980\Omega$$

In the simulation, the value of R_{in1} and R_{in2} was adjusted to 1k and 2k, respectively. A limit was also placed on the output and input currents of both V1 and V2. These limits were selected using the ISET pins, where RsetP limits the output current, and RsetN limits the input.

In the case of V1:

$$Rset1P = \frac{Rin1 * 1.21V}{Rsns1 * I1Limit} = \frac{689\Omega * 1.21V}{3m\Omega * 2.5A} = 104405\Omega$$

$$Rset1N = \frac{Rin1 * 1.21V}{Rsns1 * I1Limit} = \frac{689\Omega * 1.21V}{3m\Omega * 2.5A} = 104405\Omega$$

In the case of V2:

$$Rset2P = \frac{Rin2 * 1.21V}{Rsns2 * I2Limit} = \frac{980\Omega * 1.21V}{5m\Omega * 9A} = 23729\Omega$$

$$Rset2P = \frac{Rin2 * 1.21V}{Rsns2 * I2Limit} = \frac{980\Omega * 1.21V}{5m\Omega * 9A} = 23729\Omega$$

Each one of these resistors requires an added capacitor of a reasonable size. According to the datasheet $Cset1N = Cset2N = Cset1P = Cset2P = 10n$ should be satisfactory. Current monitoring is done through the use of monitor resistors for both V1 and V2.

In the case of V1:

$$R_{mon1} = \frac{R_{in1}}{I1Limit * R_{sns1}} * 2V = \frac{689\Omega}{2.5A * 3m\Omega} * 2V = 172571\Omega$$

In the case of V2:

$$R_{mon2} = \frac{R_{in2}}{I1Limit * R_{sns1}} * 2V = \frac{980\Omega}{9A * 5m\Omega} * 2V = 39221\Omega$$

The output voltage V1 is set using two resistors that form a voltage divider to set the FB1 pin to 1.21V. The bottom resistor (R_{fb1b}) is first selected to be 12.1k Ω , the top resistor (R_{fb1a}) is then calculated using a voltage divider equation:

$$R_{fb1a} = \left(\frac{V1}{1.21V} - 1\right) * R_{fb1b} = \left(\frac{12V}{1.21V} - 1\right) * 12.1k\Omega = 467.9k\Omega$$

Similarly, output voltage V2 is set by first selecting the bottom resistor (R_{fb2b}) to be 12.1k Ω , the top resistor (R_{fb2a}) is then calculated using a voltage divider equation:

$$R_{fb2a} = \left(\frac{V2}{1.21V} - 1\right) * R_{fb2b} = \left(\frac{48V}{1.21V} - 1\right) * 12.1k\Omega = 107.9k\Omega$$

An under-voltage threshold is also set for both V1 and V2 by using two voltage dividers to set the voltage at the UV pins. If voltage falls below the threshold voltage, the regulation mode changes from boost to buck, and the DRXN pin is pulled high by the external pullup resistor.

The top resistors of the voltage divider were calculated in the following manner.

$$R_{uv1a} = \left(\frac{(V1_{uvth} - .7V)}{1.2V} - 1\right) * R_{uv1b} = \left(\frac{(42V - .7V)}{1.2V} - 1\right) * 12.1k\Omega = 404.k\Omega$$

$$R_{uv2a} = \left(\frac{(V2_{uvth} - .7V)}{1.2V} - 1\right) * R_{uv2b} = \left(\frac{(11V - .7V)}{1.2V} - 1\right) * 12.1k\Omega = 91k\Omega$$

The second resistors were simply selected to be:

$$R_{uv2a} = R_{uv2b} = 12.1k\Omega \text{ (Selected)}$$

For all resistors that are not part of the power, their respective resistor values were selected with a tolerance of at least one percent and 1/8W power rating.

Capacitors Cdm1, Cdm2, and Cdm4 are all selected based on recommendations from the datasheet. Cdm1 is four 22 μ F ceramic capacitors to reduce ESR with an additional 68 μ F electrolytic to reduce the source impedance from V1. Cdm2 consists of three 100 μ F capacitors. Cdm4 has four 22 μ F ceramic capacitors to reduce the overall ESR with an additional 100 μ F electrolytic capacitor to reduce the source impedance from V2. Capacitors Cdg1 and Cdg2 are both selected to handle the inrush current from V1 and V2 in buck and boost mode, respectively. Their values are selected based on the following equations.

$$Cdg1 = \frac{10\mu A * (Cdm1)}{500mA} = 5.76nF \quad Cdg2 = \frac{10\mu A * (Cdm4)}{1A} = 2.76nF$$

Rdg1 and Rdg2 are resistors put in series with Cdg1 and Cdg2, respectively. Rdg1 helps stabilize the boost regulation loop and Rdg2 prevents slowdown for the DG2 turn-off speed. All additional capacitors ($Cv1 = 10\mu F$, $Cv2 = 10\mu F$, $Ctmr = 300nF$, $Cvc1 = 4nF$, $Cvc2 = 10nF$, $Css = 10nF$, $Cintvcc = 1\mu F$) included in the circuit design are selected based on the recommendations from the datasheet. Resistors Rgnd, Rfault, and Rdrxn are selected based on recommendations in the datasheet.

The Bias pin and Enable pin must have at least 8V so that the controller turns on and stays on. Two Schottky diodes, D2 and D3, are connected from V1 and V2 to these pins to ensure that these pins are set high in both Buck and Boost mode. These pins draw micro-amps of current so the DFLS160-7 Schottky diode was selected with a reverse voltage rating of 60V and a current rating of 1A.

Battery Sensing IC LTC2943

The Rsense for the LTC2943 is selected based on the equation $R_{sense} < \frac{50mV}{I_{max}}$ where I_{max} is the maximum current from the battery. This gives $R_{sense} < 5.5m\Omega$. Three 2k Ω

resistors are placed between the ALCC, SDA, and SCL pins and a 3.3V pin on the Linduino One to limit the current. A 1µF capacitor is connected from the Sense+ pin to the ground as directed by the datasheet. The Linduino DC2026C is the selected microcontroller as it is the suggested microcontroller for use with the LTC2943.

Table 4-1 shows the complete Bill of Materials listing all components required to construct the Bidirectional DC-DC converters.

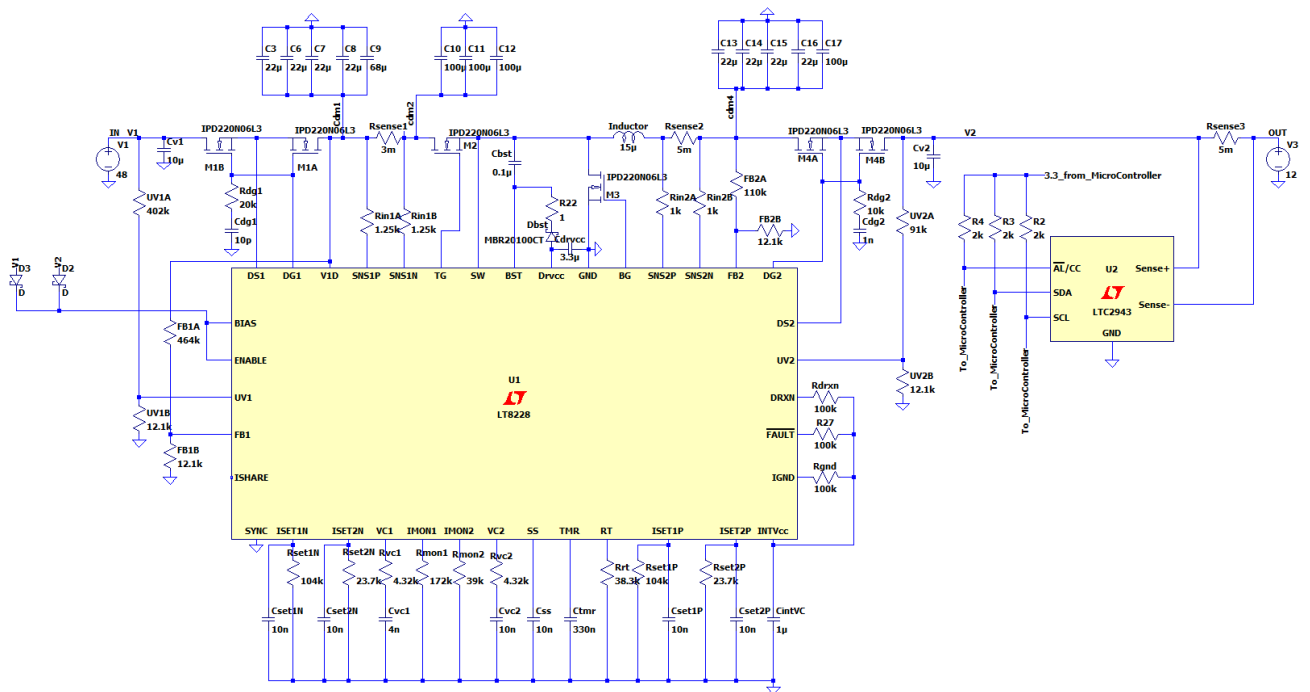

Figure 4-2: Circuit Schematic of the Bidirectional Converter

Chapter 5 Simulation

Simulation Tool:

The software LTSpice is chosen to simulate this project. The main reason why LTSpice was chosen is both the controller LT8228 and the battery sensing IC LTC2943 is manufactured by Analog Devices, the same company behind the software LTSpice, and thus are already integrated into the software. Additionally, LTSpice is chosen due to it being free meaning it was easily accessible to us and to anyone who might want to build on or confirm results at a later time. Lastly, LTSpice was chosen due to its user-friendly interface in building a circuit and placing a new component and changing its value.

Simulation Setup:

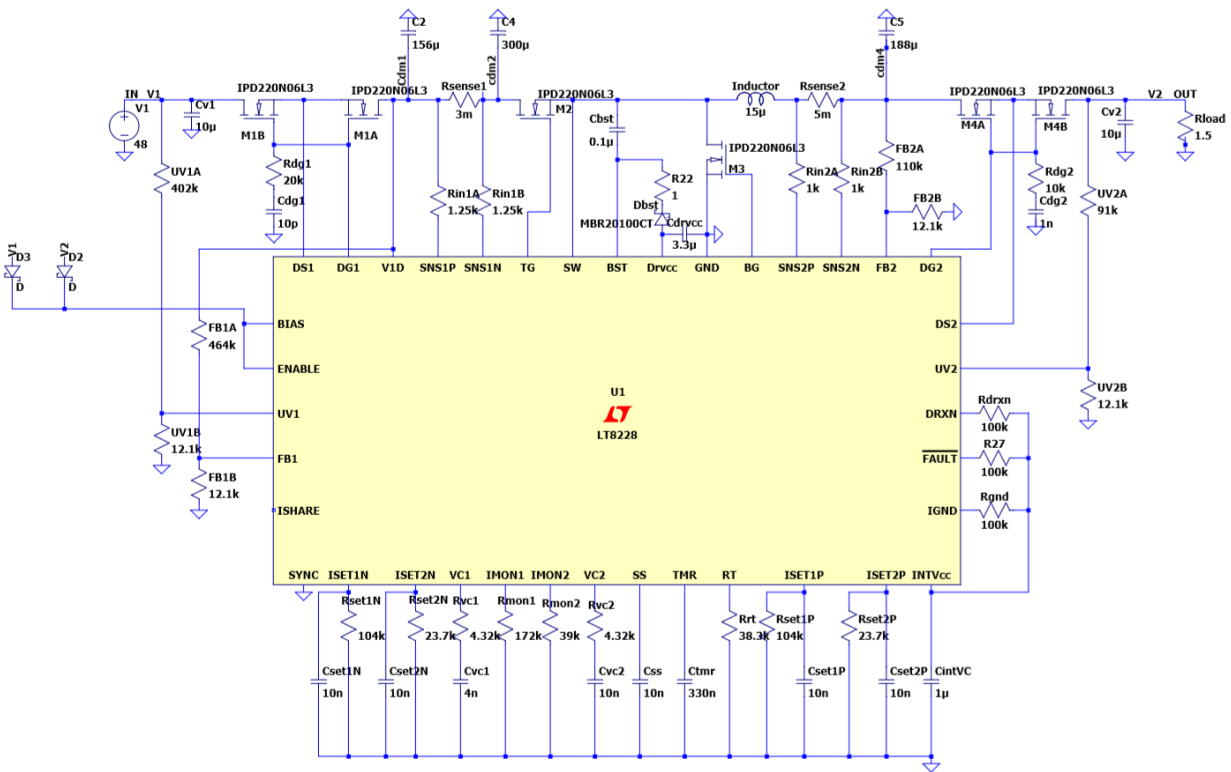

Figure 5-1: Simulation Schematic

In order to determine the operating efficiency of the buck and boost mode outputs, a resistive load was placed at the output to achieve specific output currents. Figure 5-1 shows the Buck mode setup. When testing the Boost mode efficiency, the resistive load is placed at V1 and the Voltage source is placed at V2. In both modes, the load was stepped for 10% to 100% of the

expected full load in iterations of 10% to compare the efficiency at each interval. The converter will be working under various loads in order to supplement the power provided to the DC House through the DC Bus. A voltage range of approximately $\pm 5\%$ was used for the input voltage in buck and boost modes to calculate the line regulation of the converter. Using the 10% and 90% load values, the load regulation was calculated.

Buck Mode

In buck mode, the input voltage is 48V and the output voltage is 12V. The expected output current is 8A and the input current is 2A at full load. These values would step down by .8A and .2A respectively as the load steps down 10%. At full load, the efficiency is 86% which is lower than the expected 94%. However, when compared to simulation data provided with the LT8228, our efficiency more closely matches up to the expected 87%. Part of this discrepancy is likely due to this design being for much lower power applications than the peak efficiency designs are. More specifically, this design is for an 8A output current compared to the 40A design that the chip allows for. The lower current also requires a lower current limit which increases the size of the Rsns sensing resistors. The datasheet recommends using a smaller Rsns value to achieve the highest efficiency.

Load Percentage	Eff
100%	0.866
90%	0.867
80%	0.878
70%	0.878
60%	0.877

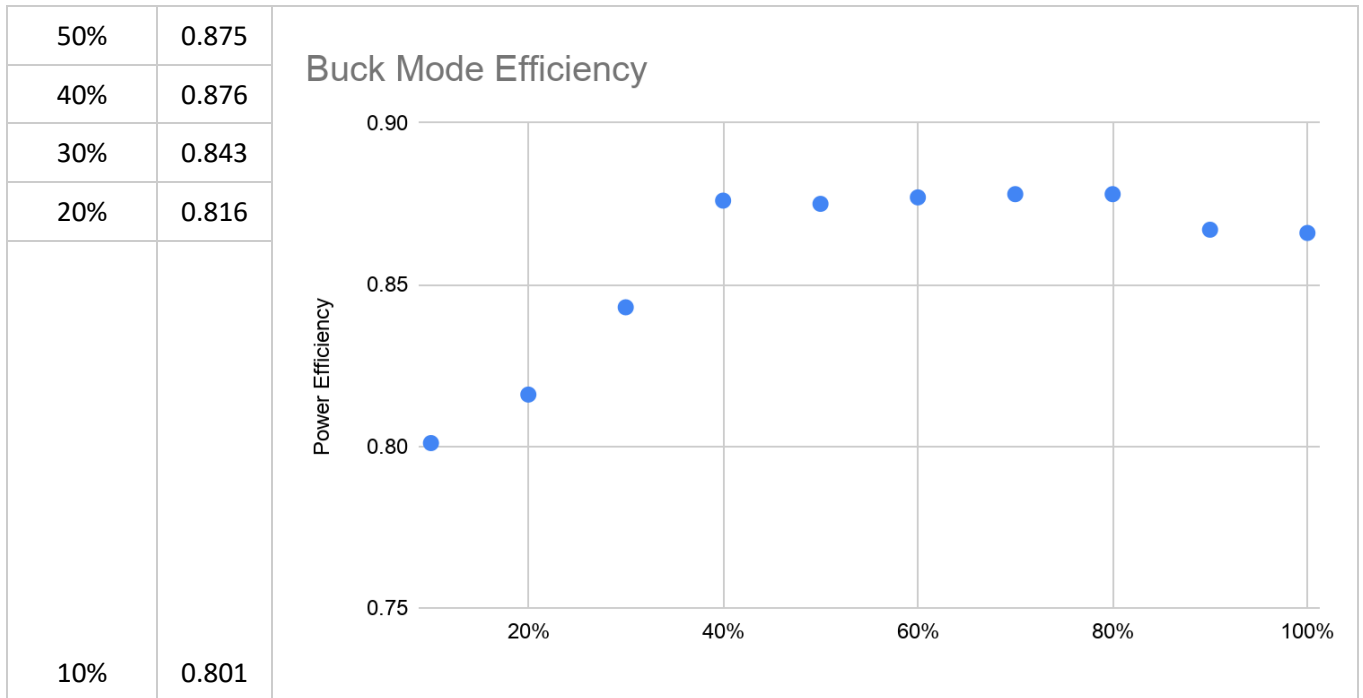

Figure 5-2: Buck Mode Efficiency at different loads

The output voltage in buck mode at full load is found to have an average value of 11.9V with about 0.045% percent ripple. Ideally, the output voltage should have no voltage ripple as it should be a DC voltage. A ripple of .045% is a negligible amount which is ideal for this design.

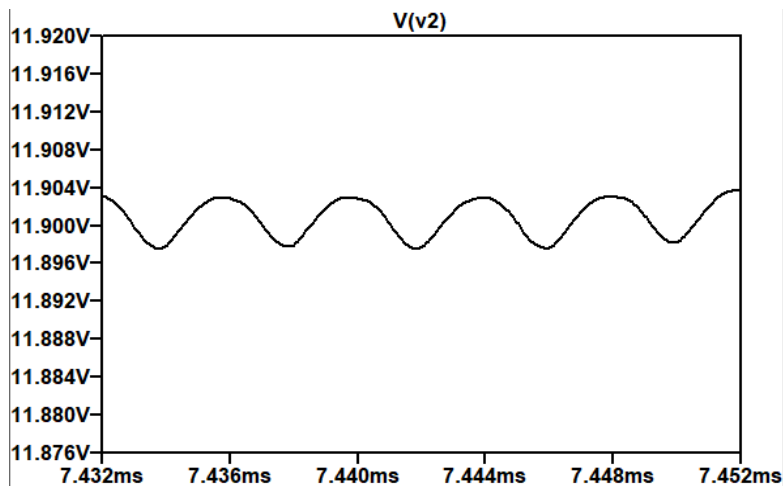

Figure 5-3: Buck Mode Output Voltage Full Load

The average inductor current in buck mode is found to be 7.096A with a current ripple of about 2.46A, which is about 34% of the average right in line with the 35% ripple that was calculated. From the critical waveforms, it becomes evident that M2 is acting as the main switch in this configuration, and M3 is acting as the synchronous switch. It is seen that the synchronous diode stays on for the majority of the time which is as expected for a buck converter with large input-output voltage decrease.

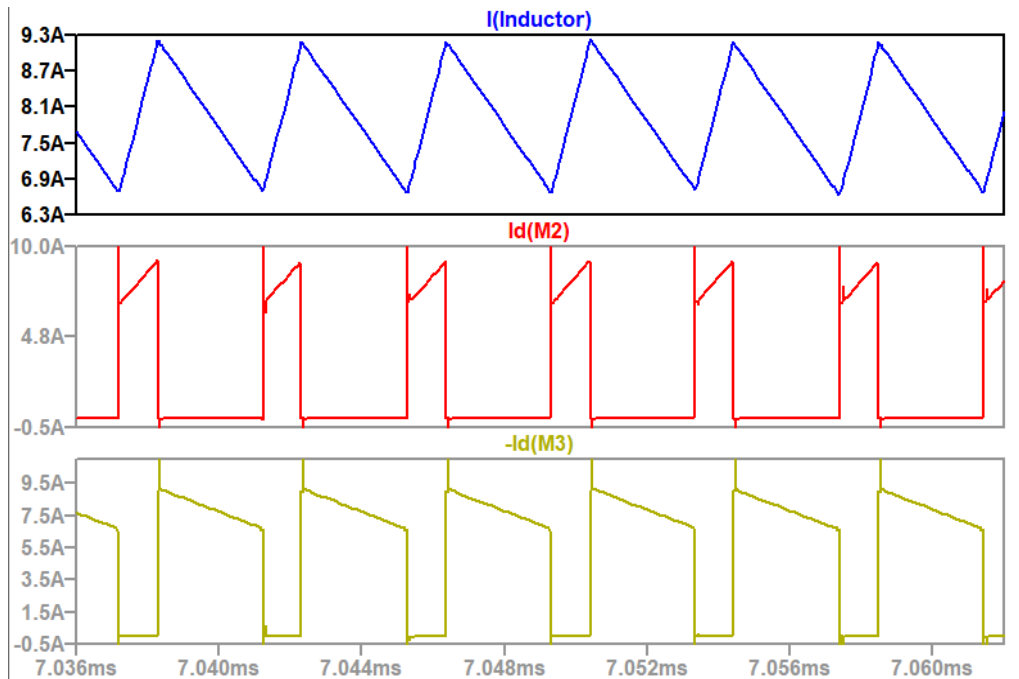

Figure 5-4: Buck Mode Critical Waveforms Full Load

Boost Mode

In boost mode, the input voltage is 12V and the output voltage is 48V. Assuming ideal operation with no loss, the expected output current is 2A and the input current is 8A at full load. These values would step down by 0.2A and 0.8A respectively as the load steps down 10%. At full load, the efficiency is 84%, which is lower compared to the expected 93% from the datasheet. However, the simulation data provided in LTspice gives a lower efficiency of around

88% which more closely matches the measured efficiency. Similar to the buck mode, the lower power design requires a lower current limit to ensure a safe converter. The current limit has a large impact on efficiency as it increases the Rsns resistor values which in turn increases the value of many other resistors resulting in a greater power loss.

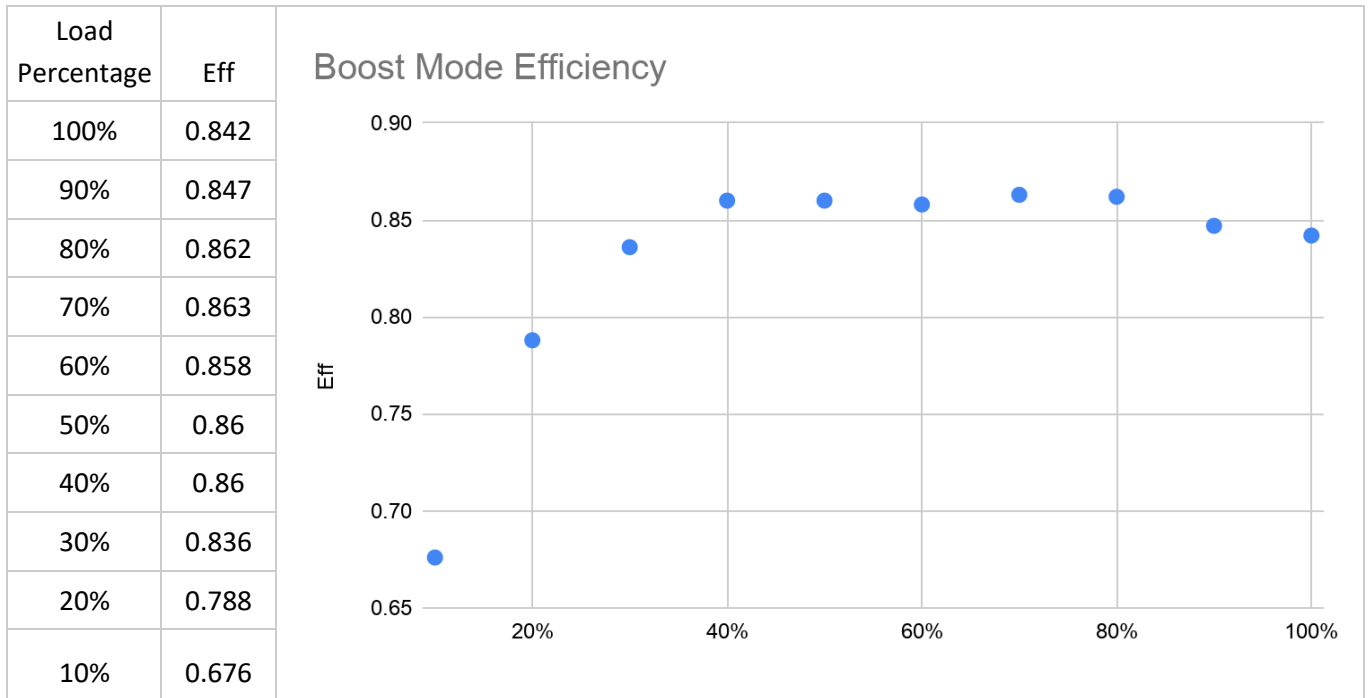

Figure 5-5: Boost Mode Efficiency at different loads

The output voltage in boost mode at full load is found to have an average value of 47.456V with a ripple of about 0.018% percent. Ideally, the output voltage should have no voltage ripple as it should be a DC voltage. A ripple of 0.018% is a negligible amount which is ideal for this design.

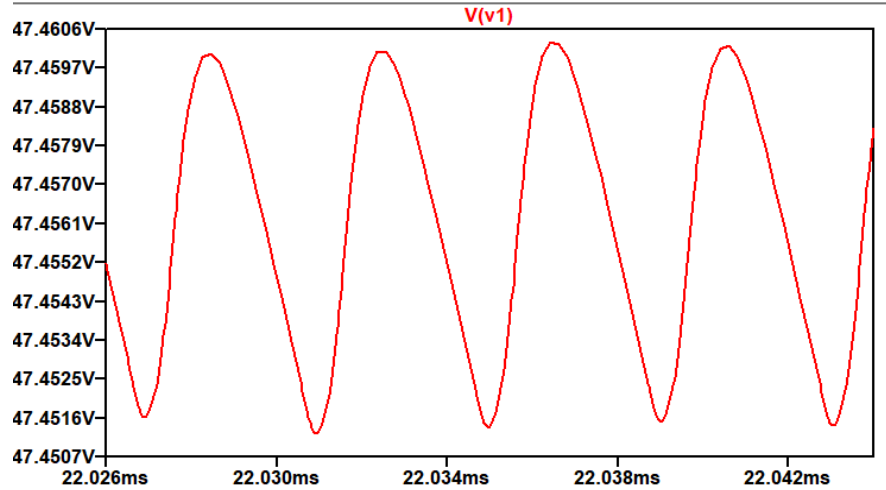

Figure 5-6: Boost Mode Output Voltage Full Load

The average inductor current in boost mode is found to be 9.2A with a current ripple of about 2.25A which is about 24% of the average current which is under the 35% ripple accounted for which is a good thing. From the critical waveforms, it becomes evident that M3 is acting as the main switch in this configuration, and M2 is acting as the synchronous switch which is the opposite of what we found in the buck mode. It is seen that the synchronous diode stays on for the majority of the time which is as expected for a boost converter with large input-output voltage rise.

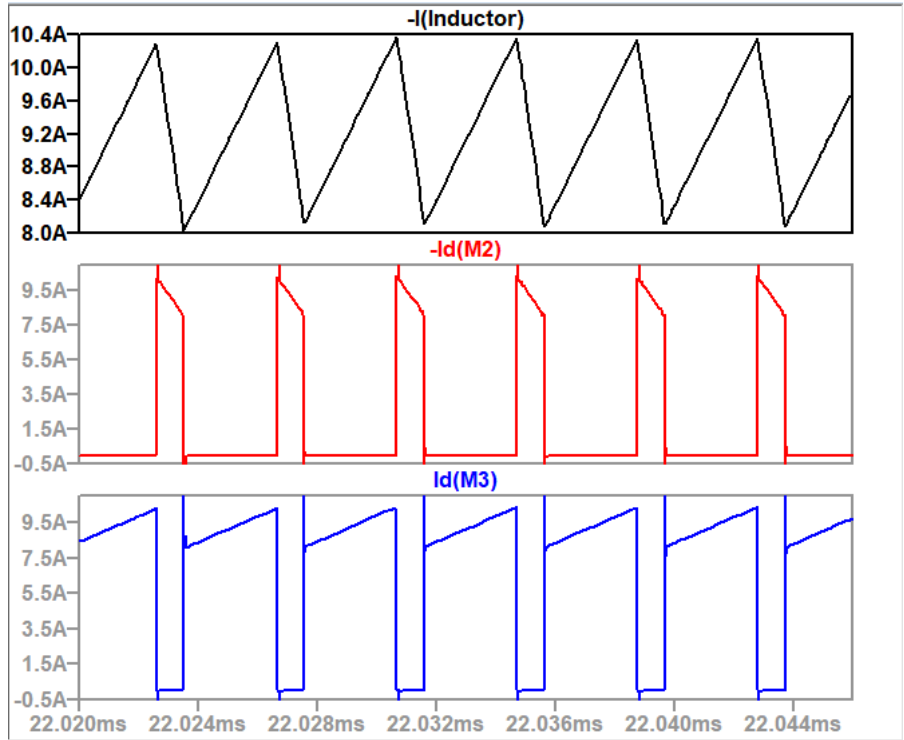

Figure 5-7: Boost Mode Critical Waveforms Full Load

Line and Load Regulations

To calculate line regulation, a full load is used and the input voltage was adjusted by $\pm 5\%$ from the nominal values for buck and boost modes. In buck mode, the input was tested at 45V, 48V, and 51V while in boost mode it was tested at 11.5V, 12V, and 12.5V. Table 5-1 shows the output voltages measured at each input voltage.

Table 5-1: Line Regulation Values

Buck	Vin [V]	Vout [V]	Boost	Vin [V]	Vout [V]
Vlow	45	11.91	Vlow	11.5	47.394
Vhigh	51	11.94	Vhigh		47.456
Vnom	48	11.9	Vnom	12	47.45

Line regulation is calculated using the following equation,

$$Line = \frac{V_{out}(high) - V_{out}(low)}{V_{out}(nom)} \times 100\%$$

For buck mode, line regulation was .25%, and for boost mode line regulation was .13%.

Generally, buck converters will have a low line regulation and boost converters will have higher line regulations. This converter has a low line regulation for both meaning that changes in the input voltage will have a very low effect on the output voltage. Both are well below the 2% regulation mark.

In order to calculate the load regulation, the output voltage was measured at the 10% and 90% loads in both buck and boost mode. This was done using resistive loads of 1.667Ω and 7.5Ω for buck mode, while for boost mode resistor values used were 24Ω and 120Ω.

Table 5-2: Load Regulation Values

Buck	Load	Vout [V]	Boost	Load	Vout [V]
Low	10%	12.16	Low	10%	47.53
High	90%	11.948	High	90%	47.45

Load regulation is then calculated by the equation

$$Line = \frac{V_{out}(low) - V_{out}(high)}{V_{out}(high)} \times 100\%$$

For buck mode, the line regulation was 1.55% and for boost mode it was .147%. Low load regulation is ideal as it means that the output voltage does not react to changes in the load current. Generally, buck converters have poor load regulation while boost converters will normally have good load regulation. This is highlighted as the load regulation for the boost mode is roughly 10x smaller than buck mode. Both are below the 2% benchmark which is ideal.

PCB Layout:

Autodesk Eagle was chosen to make a PCB layout since there is a free version available to download. This software is easy to use and has many of the features that paid PCB software have. Most of the components used have libraries available online to download and import into Eagle. This made the process easier since footprints and symbols are not needed for every component. Figure 5-6 shows the top layer of the preliminary board layout design for the bidirectional converter in this project. The bottom layer will be just the ground plane of the converter. The design takes into consideration the separation of the power stage and control stage of the converter assuming a two layered board. However, the physical size has not yet been optimized. Furthermore, due to the current pandemic, the actual hardware prototype will not be constructed to demonstrate the functionality and operation of the proposed design.

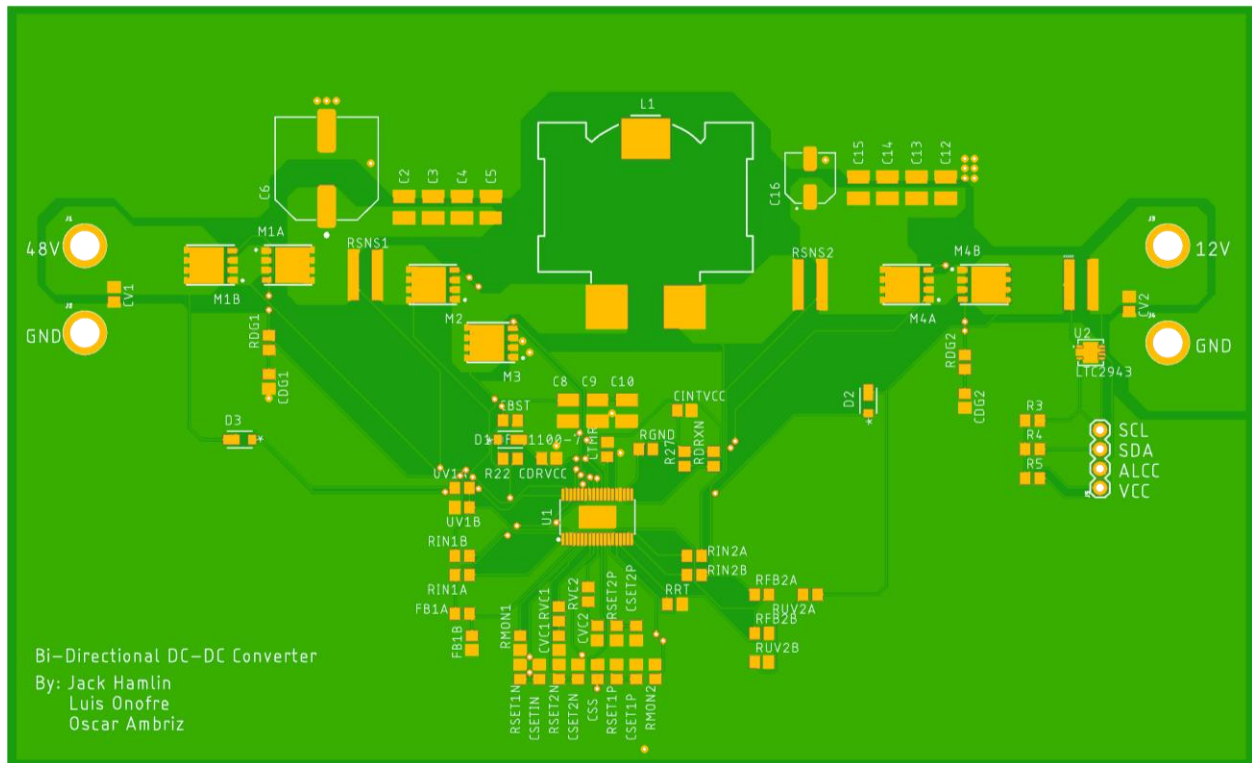

Figure 5-8: PCB layout top layer

Chapter 6: Conclusion

This project focuses on exploring alternative converter formats and chips to improve on the efficiency and cost of the previously designed Energy Management System (EMS) for the DC House project. In addition, this project aims to determine an alternative chip to perform the State of Charge (SoC) monitoring of the EMS. An improved PCB design was also conducted to place both the converter IC and the SoC IC on the same board rather than on two separate boards; thus, reducing the overall size and price of the EMS system. The previous iteration of this system used a demo board, which made up a big portion of the total cost coming in at \$375.00; however, this design would reduce the overall price significantly, costing less than \$100 for parts and the printing of the circuit board.

Initially, the project also entailed the hardware construction of the design. Unfortunately, this goal could not be achieved due to the COVID-19 pandemic which caused campus shut down with all the labs being closed. This made it impossible for doing the hardware testing unless a home lab with all the required testing equipment was set up.

The simulation results of the DC-DC converter showed less than ideal results. An efficiency of 86% and 84% at full load in buck mode and boost mode respectively was below the previous design. One advantage was that the efficiency remained fairly constant around 87% in buck mode and 85% in boost mode at lower loads. This converter will run more efficiently during daytime and evening hours where less power will need to be provided from the battery but worse during the night where all the power will need to come from the battery.

One area yet to be tested is the long-term functionality of the system. The simulation software does not have a true battery component to test. On top of this, there is no way to

simulate battery usage over an entire day which is a crucial part of this design. The automatic switching between modes also requires testing as this feature was not possible in simulation.

Design improvements

One of the issues noticed while testing our current controller is that it functions most efficiently at loads higher than those required by the DC House. If in the future an alternative controller is desired, we recommend selecting one controller that operates well at relatively low loads. The LT8708 controller from Analog Devices according to its datasheet should reach above 90% efficiency at a load of just 0.3A [9]. Another controller with desired specifications is the LM5170. The controller also promotes high efficiency at low loads, and it is specifically made for a 12V-48V application [10].

Another aspect of improvement would be the use of ORCAD Capture CIS over LTSpice. LTSpice ran into simulation speed issues while collecting data due to the complexity of the circuit design. ORCAD could have a more robust simulation profile that will allow for more efficient waveform calculations. ORCAD also has the ability to show the waveforms for the average and RMS current and voltages while LTSpice can only show a single value.

Future design of the EMS would want to increase the maximum input and output currents. Both maximum values for the currents have a significant impact on the efficiency due to their effect on the Rsense resistors. The Rsense resistors change the values of the Rin resistors which affect the current gain amplifiers. By increasing the current maximums, the resistor values will be decreased which will allow for increased overall efficiency.

Overall, this EMS design made some improvements over the previous iterations but there is still room for improvement. Given that this design was only simulated, the hardware

implementation of this design might need some minor modifications to obtain the simulated results.

References

- [1]. "Rural electrification: The DC House solution", The Economist, Powering Up: Perspectives on Indonesia's Energy Future, Jan 2014.[Online].
- [2]. C. Venter, A. Raji and M. Adonis, "The DC house for low power households - DC-DC converter analysis," 2015 International Conference on the Domestic Use of Energy (DUE), Cape Town, 2015, pp. 143-146.
- [3]. S. Saha, A. Bhattacharjee, D. Elangovan and G. Arunkumar, "DC microgrid system for rural electrification," 2017 International Conference on Energy, Communication, Data Analytics and Soft Computing (ICECDS), Chennai, 2017, pp. 307-313.
- [4]. M. Riiny, "South sudan rural electrification project the hybrid mini-grid & PBK project," IEEE Global Humanitarian Technology Conference (GHTC 2014), San Jose, CA, 2014, pp. 25-27.
- [5]. Eldredge, Z. and Hay, Z., "DC House Energy Management System," Dept. Electrical Eng., California Polytechnic State Univ., CA, 2017.
- [6]. T. Taufik, "Research Experience on the DC House Project for Rural Electrification," 2017 International Conference on Computational Science and Computational Intelligence (CSCI), Las Vegas, NV, 2017, pp. 267-270.
- [7]. LT Electronics Co, "LT8828 Bidirectional Synchronous 100V Buck/Boost Controller with Reverse Supply, Reverse Current and Fault Protection," LT8228 datasheet. [Online] Available: <https://www.analog.com/media/en/technical-documentation/data-sheets/LT8228.pdf>
- [8]. LT Electronics Co, "Demo Manual DC2351A LT8228 High Voltage, High Efficiency Bidirectional Synchronous Buck or Boost Converter with Input and Output Circuit Breakers," DC2351A datasheet. [Online] Available: <https://www.analog.com/media/en/dsp-documentation/evaluation-kit-manuals/DC2351A.pdf>
- [9]. LT Electronics Co, "LT8708 80V Synchronous 4-Switch Buck-Boost DC/DC Controller with Bidirectional Capability," LT8708 datasheet. [Online] Available: <https://www.analog.com/media/en/technical-documentation/data-sheets/LT8708.pdf>
- [10]. Texas Instruments, "LM5170 Multiphase bidirectional current controller," LM5170 datasheet. [Online] Available: <https://www.ti.com/lit/ds/symlink/lm5170.pdf?ts=1590779219360>

Appendix A: Final Schematic

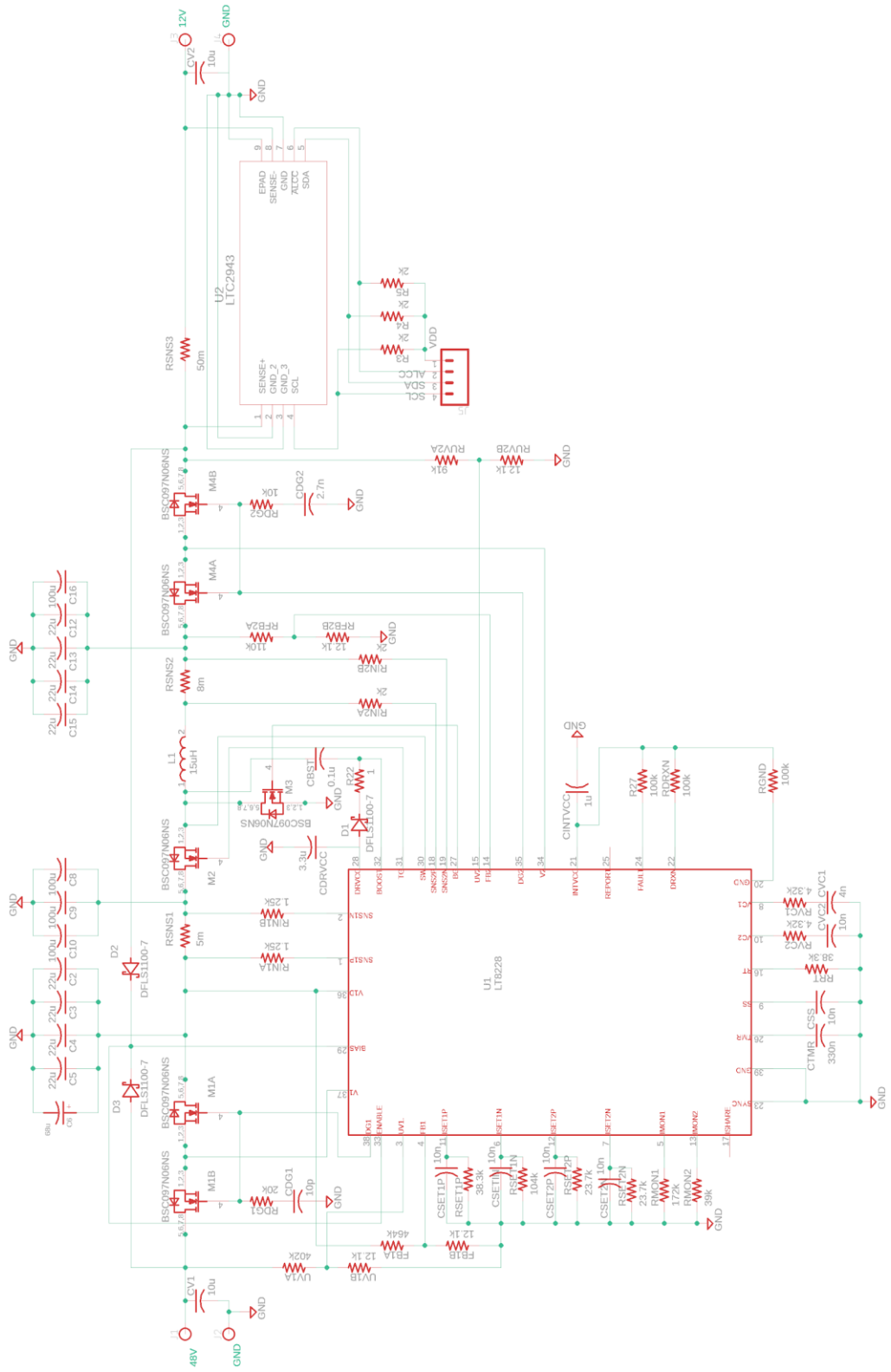

Appendix B: Bill of Materials

RefDes	Quan.	Value	Description	Size	Part Number	Manufacturer	Per Unit Cost \$
U1	1	LT8228	Bidirectional Buck/Boost controller	38-TFSOP	LT8228EFE#P BF	Analog Devices	15.99
U2	1	LTC2943	Battery Monitor IC	8-WDFDN	LTC2943CDD #PBF	Analog Devices	5.85
L1	1	15uH	FIXED IND 15UH 30A 2.4 MOHM	28.5mm x 19.5mm	7443641500.0 0	Würth Elektronik	9.35
M1A, M1B, M2, M3, M4A, M4B	6	Switch	MOSFET N-CH 60V 46A	TDSON-8	BSC097N06N SATMA1	Infineon Technologies	0.83
FB1A	1	464k	RES 0.1% 1/8W	805	ERA- 6AEB4643V	Panasonic Electronic Components	0.34
FB1B, FB2B, RUV1b, RUV2b	4	12,1k	RES SMD 0.1% 1/10W	805	RN73C2A12K 1BTDF	TE Connectivity Passive Product	0.83
FB2A	1	107k	RES 0.1% 1/8W	805	ERA- 6AEB1073V	Panasonic Electronic Components	0.34
RT	1	38.3k	RES SMD 0.1% 1/10W	805	RN73C2A38K 3BTDF	TE Connectivity Passive Product	0.83
Rsense1	2	3m	RES 0.003 OHM 1W 0805 WIDE	805	KRL2012E- M-R003-F-T5	Susumu	0.63
Rsense2, Rsense3	1	5m	RES 3W 2512 WIDE	2512 WIDE	KRL6432E- M-R005-F-T1	Susumu	0.97
Rin1A, Rin1B	2	1k	RES SMD 1K OHM 5% 1/10W 0603	603	RC0603JR- 071KL	Yagao	0.10
Rin2A, Rin2B	2	1.24k	RES 1.24K OHM 0.1% 1/8W 0805	805	ERA- 6AEB1241V	Panasonic Electronic Components	0.34
Rset1P, Rset2N	2	104k	RES 104K OHM 0.1% 1/10W 0603	603	RN73HIJTTD 1043B50	KOA Speer	0.55
Rset2P, Rset2N	2	23.7k	RES SMD 23.7KOHM 0.1% 1/10W 0603	603	ERA- 3AEB2372V	Panasonic Electronic Components	0.34
Rmon1	1	172k	RES SMD 169K OHM 1% 1/20W 0201	201	ERJ- 1GNF1693C	Panasonic Electronic Components	0.10
Rmon2	1	39k	RES SMD 39K OHM 0.5% 1/16W 0603	603	RR0816P-393- D	Panasonic Electronic Components	0.11
Ruv1a	1	402k	RES SMD 402K OHM 1% 1/8W 0805	805	CRCW080540 2KFKEA	Vishay Dale	0.10
Ruv2a	1	91k	RES 91K OHM 0.1% 1/8W 0805	805	ERA- 6AEB913V	Panasonic Electronic Components	0.34

Rgnd, Rfault, Rdrxn	3	100k	RES 100K OHM 0.1% 1/8W 0805	805	ERA-6AEB104V	Panasonic Electronic Components	0.34
Rdg1	1	20k	RES SMD 20K OHM 1% 1/8W 0805	805	ERJ-6ENF2002V	Panasonic Electronic Components	0.10
Rdg2	1	10k	RES 10K OHM 0.5% 1/8W 0805	805	ERA-6AED103V	Panasonic Electronic Components	0.11
Cv1, Cv2	2	10uF	CAP CER 10UF 100V X7S 1210	1210	GRM32EC72A106KE05L	Murata Electronics	1.51
C2-C5, C12-C15	8	22uF	CAP CER 22UF 25V X5R 1210	1210	C1210C226K3 PACTU	KEMET	0.83
C6	1	68uF	CAP ALUM 68UF 20% 80V SMD	0.531" L x 0.531" W	EEV-FK1K680Q	Panasonic Electronic Components	1.40
C16	1	100uF	CAP ALUM POLY HYB 100UF 25V SMD	0.260" L x 0.260"	EEH-ZA1E101XP	Panasonic Electronic Components	1.87
C8-C10	3	1uF	CAP CER 1UF 100V X7R 1206	1206	C1206C105K1 RACTU	KEMET	0.55
Cdg1	1	5.6nF	CAP CER 5600PF 100V X7R 0805	805	C0805C562K1 RAC7800	KEMET	0.33
Cdg2	1	2.7nF	CAP CER 2700PF 50V X7R 0805	805	C0805C272K5 RACTU	KEMET	0.21
Ctmr	1	330nF	CAP CER 0.33UF 50V X7R 0805	805	C0805C334K5 RACAUTO	KEMET	0.23
Cvc1	1	3.9nF	CAP CER 3900PF 50V X7R 0805	805	C0805C392J5 RACTU	KEMET	0.43
Cvc2, Css, Cset1N, Cset2N, Cset1P Cset2P	6	10nF	CAP CER SMD 0805 .01UF X7R 5% 50	805	C0805C103J5 RAC7210	KEMET	0.11
CintVC, C1	1	1uF	CAP CER 1UF 25V X7R 0805	805	C0805C105K3 RACTU	KEMET	0.15
D1, D2, D3	3	DFLS16 0-7	DIODE SCHOTTKY 60V 1A	POWERD I123	DFLS160-7	Diodes Incorporated	0.44
R3, R4, R5	3	2k	RES 2K OHM 0.1% 1/8W 0805	805	ERA-6AEB202V	Panasonic Electronic Components	0.36
C1	1	1uF	CAP CER 1UF 25V X7R 0805	805	C0805C105K3 RACTU	KEMET	0.15
Total:				Component Count			69
				Cost			\$47.06

Appendix C: Analysis of Senior Project

Project Title: Bi-Directional DC-DC Converter

Student Names: Oscar Ambriz, Luis Onofre, Jack Hamlin

Advisor's Name: Professor Taufik

1. Summary of Functional Requirements

The Bi-Directional DC-DC converter assists the battery management of a DC house. It assists with the flow of power from a renewable source to the battery system and from the battery system to the DC house. The DC house operates at 48V and is connected to a 12V battery system. This was done using the LT8228 Bi-directional DC-DC controller which works with Buck and Boost topologies, allowing for both the stepping down and stepping up of voltage.

2. Primary Constraints:

The primary constraints for this project is that it must be Bi-Directional, so only one converter for the step-down and step-up of the voltage, it must support a 12V battery system and it must also be able to output 100W for up to 12 hours.

3. Economic:

What economic impacts result:

Human Capital:

The development of this product will create jobs in the engineering sector primarily electrical engineers and manufacturing engineers. A couple of jobs will also be created for marketing and sales.

Financial Capital:

This product is intended for non-profit, for people in rural areas that don't have access to the grid, but this product can also be useful for people living off the grid here in the United States.

Natural Capital:

The production of this product will mostly consist of electronic components. These parts are difficult to recycle because of the material that these components are made of.

4. If manufactured on a commercial basis:

Estimated number of devices sold per year: Around 100 units the first year

Estimated manufacturing cost for each device: \$100

Estimated purchase price for each unit: \$200

Estimated profit per year: \$10,000

Estimated Cost for User to operate device: \$0(running on renewable energy source)

5. Environmental Impact:

What environment impacts are associated with the manufacturing of the product:

This product will likely be used with many components that are not easily recyclable such as the battery or the solar panels that would likely be used for the power

source. Severe environmental impacts could occur if these products are not recycled correctly because of the chemicals. Which natural resources and ecosystem services does the project use (directly and indirectly) improve or harm?

This product will use several electrical components that are made from several natural resources. The process involved in the mining of these components can be very harmful to the environment. To reduce this impact research will be done on the manufacturers that we purchase components from.

Does the project impact other species?

Our project could be used with wind turbines, which could potentially harm birds and other animals.

6. Sustainability:

Describe any issues or challenges associated with maintaining the complete device or system

One challenge associated with maintaining this device is that because this device will mostly be used in isolated remote areas there will be a lack of support if the device needs troubleshooting.

Describe how the project impacts the sustainable use of resources.

Our project supports the use of renewable energy sources because it regulates the power generated from a renewable energy source.

Describe any upgrades that would improve the design of the project

Improving the efficiency of the converter by choosing more expensive components for the converter would improve the design of a project a great amount.

Describe any issues or challenges associated with upgrading the design.

Choosing more efficient components creates a great challenge for our project. This is due to the fact that we are trying to provide this product at the lowest price possible.

7. Ethical:

For the Bi-Directional DC-DC converter, one ethical concern is that this design will likely be used with many components that are not easily recyclable such as the battery or the solar panels that would likely be used for the power source. On top of this, solar cells have potentially hazardous materials used in their creation and in the heat transfer system. This creates an issue of sustainability because these products will end up in landfills or create pollution in areas that cannot easily handle the safe disposal or recycling of these devices. While cleaner components likely exist for all parts in this design, they will come with a much higher price which is not compatible given the target market and focus on humanitarian needs. Because of this, it is unlikely that a fully green product can be created. However, we can put an emphasis on designing the product to be as sustainable as possible without increasing the cost of creating this product so as to keep the potential pollution levels as low as possible. Another possible solution is to ensure that we include directions for proper disposal of this product when it is installed so that it is disposed of

properly at the end of its lifetime. We can also be on the lookout for cost efficient design components that are safer for the environment to be used in future iterations of the design.

8. Health and Safety:

The safety concerns surrounding our product are mainly due to the high voltages coming in and out our converter. If the user decides to open the enclosure and touch any portion of it which is conductive there is a possible injury which could result. There is also a concern with our battery. Our converter controls the input to our battery which means that if it were to fail it could lead to a failure in the battery as well which could be potentially dangerous depending on the current state of the battery. Any manufacturing of electrical devices poses health risks to the workers due to the hazardous material required in the manufacturing process.

9. Social:

The converter overall should lead to a positive social impact. The main purpose of the converter is to help a population who lacks access to electricity. By implementing our device in these areas, we will help in providing more opportunities to those who have been limited by a lack of access to reliable power .