

Compression Tester Shop Press

Final Design Report

Mechanical Engineering Department

California Polytechnic State University

San Luis Obispo

2014



Sponsor: Geoffrey Wheeler

Colby Johnson
colbyjohnson128@gmail.com

Brett Russon
brusson4@gmail.com

Taylor Vandenhoeck
tj.vandenhoeck@gmail.com

Statement of Disclaimer

Since this project is a result of a class assignment, it has been graded and accepted as fulfillment of the course requirements. Acceptance does not imply technical accuracy or reliability. Any use of information in this report is done at the risk of the user. These risks may include catastrophic failure of the device or infringement of patent or copyright laws. California Polytechnic State University at San Luis Obispo and its staff cannot be held liable for any use or misuse of the project.

Table of Contents

CHAPTER 1: Introduction	5
Sponsor Background	6
Objectives	6
CHAPTER 2: Background	9
Existing Products	9
Applicable Standards	9
Patent Searches	9
CHAPTER 3: Design Development	10
Top Frame and Slider Concepts	10
Concept 1: Four Poled Model	10
Concept 2: H-Frame with I-Beam Structural Members	10
Concept 3: H-Frame with C-Channel Structural Members	11
Concept 4: Hydraulic Jack on Bottom	11
Top Bearing/Bushing Tool Attachment Concepts	12
Concept 1: Recessed Magnet	12
Concept 2: Threaded Hole in I-beam	12
Concept 3: Through Hole in I-beam with Nut and Bolt	12
Selection	12
Physical Models:	13
Pugh Matrices:	13
Weighted Decision Matrices:	13
Preliminary Final Concept	15
CHAPTER 4: Description of Final Design	16
Design Changes	16
Finalized Design	19
Failure Mode Analysis	24
Final Design Analysis	24
Final Cost Breakdown	30
CHAPTER 5: Product Realization	31
Differences from Planned Design	39

Recommendations for Future Manufacturing	39
CHAPTER 6: Design Verification	40
CHAPTER 7: Conclusions and Recommendations	45
Appendix A: Quality Function Diagram.....	46
Appendix B: Patent Search Results	47
Appendix C: Initial Design Requirements.....	48
Appendix D: Preliminary Calculations.....	50
Appendix E: Pugh Matrices	52
Appendix F: Weighted Design Matrices.....	55
Appendix G: Safety Checklist	56
Appendix H: Gantt Chart	57
Appendix I: Design Failure Mode and Effect Analysis.....	58
Appendix J: Design Verification Plan.....	61
Appendix K: Calculations.....	62
Appendix L: Engineering Drawings	79
Appendix M: Safety and Operation Manual	96
Safety Hazards.....	96
Pinch Points:.....	96
Crushing:	96
High Forces:.....	96
Operation Manual.....	97
Assembly and Disassembly	97
Compression Test.....	98
Bending Test.....	99
Shop Press Functionality: Pushing Bushings/Bearings.....	100
Hydraulic Jack Recompression	101
Determining Stress and Force Using the Gauge	103
Appendix N: Pressure Conversion Table	104

Table of Figures

Figure 1 Four Poled Model.....	10
Figure 2 H-Frame and I-Beam Model.....	10
Figure 3 H-Frame with C-channel Model.....	11
Figure 4 Hydraulic Jack on Bottom Model.....	11
Figure 5 Models for concepts 1, 2, and 4 (left to right).....	13
Figure 6 Machine in compression test (left) and bearing pushing (right) configuration.....	15
Figure 7 Design changes from preliminary concept to final design.....	16
Figure 8 Frame adjustability mechanism.....	17
Figure 9 Implementation of the hydraulic jack recompression mechanism.....	18
Figure 10 Angle iron feet- previously C-channels.....	18
Figure 11 Finalized frame configuration.....	19
Figure 12 Final sliding press plate design. Includes angle irons, steel contact plate and jack recompression tab.....	20
Figure 13 Machine in bearing pressing configuration.....	21
Figure 14 Bearing pressing tool attachment- rod and flat plate.....	21
Figure 15 Doublers, shown added to the vertical members and upper beams.....	22
Figure 16 Machine configured for jack recompression (left) and compression handle (right).....	23
Figure 17 Final frame design, constructed of C-channels and angle iron.....	25
Figure 18. Upper beams modeled as simply supported.....	25
Figure 19 Critical stress areas in C-channel cross section.....	26
Figure 20. Lower fixed beam model.....	27
Figure 21 Analysis model for shear in bolts.....	28
Figure 22 Analytical schematic for bearing stresses.....	29
Figure 23 Weld analysis model.....	29
Figure 24. Manufacturing process flow chart.....	31
Figure 25. Cutting C-channel members with horizontal band saw.....	32
Figure 26. Welding frame wall doubling plates to c-channels.....	32
Figure 27. Cooling bit and work piece while drilling holes in c-channel.....	33
Figure 28. Tack welding base assembly.....	34
Figure 29. Checking fit of tack welded slider assembly.....	34
Figure 30. Aligning feet with frame.....	35
Figure 31. (Left) Rust-oleum protective enamel, hunter green, 7738730. (Right) First coat of paint drying.....	36
Figure 32. Hole for ¼" NPT tap being drilled.....	36
Figure 33. Tapping high pressure access hole.....	37
Figure 34. (Left) Cutting 1/4" NPT threads for hydraulic fittings. (Right) Cleaning shavings from jack with compressed air.....	37
Figure 35. Jack with 15000 psi rated fittings.....	38
Figure 36. Final assembly of press.....	38

Figure 37. (Left) Press arranged in compression testing configuration. (Right) ICEB beginning to fail at corner..... 41

Figure 38. Total failure of ICEB..... 42

Figure 39. View of 20-ton point load testing configuration (left and center) and jack gauge during the test (right). 43

Figure 40. Pinch points in the press. 96

Figure 41. Compression test set up. 98

Figure 42. Bending test set up. 99

Figure 43. Bearing/bushing pressing set up..... 100

Figure 44. Jack fluid pressure release mechanism..... 101

Figure 45. (Left) Jack recompression rod. (Right) Jack recompression tab. 102

Figure 46. (Left) Jack recompression set up. (Right) Jack handle, to be used for recompression lever... 102

CHAPTER 1: Introduction

The Center for Vocational Building Technologies (CVBT) has given us the task of designing and prototyping a Compression Tester Shop Press. The need for this project is driven by the CVBT's current compression tester, which has several unfavorable characteristics:

1. Unable to perform bending tests on the 45x45cm paving slabs.
2. Unable to remove or install bushings and bearings from machinery.
3. Inefficient use of materials leads to increased weight.

The goal of the project is to ensure that the shop press design addresses these issues in order to create a machine that better meets the need of the CVBT. The Shop Press will be used for two different tests on two different items manufactured by CVBT:

1. Destructively test the compressive strength of Interlocking Compressed Earth Blocks (ICEB). This test requires a machine to compress a block with an evenly distributed force of up to 20 tons.
2. Non-destructively test the bending strength of ornamental concrete paving slabs. This test requires a machine to apply a load of up to 5 tons to 3 metal rods which hold the slab in a simply supported configuration with a point load.

In order to get accurate results from the two tests, it is imperative that the frame of the press be very rigid and able to withstand the forces that the hydraulic jacks will be exerting on it. This will be the main goal in mind throughout the design process of the shop press.

In addition to performing the two above-mentioned strength tests, the press will also be used to remove and install bushings and bearings from two machines in use by the CVBT, the BP8 Block Press and the VT4 Vibration Table, as set out by the requirements shown in the Compression Tester Shop Press Specifications Sheet in **Appendix C**. The block press is a machine that compresses a mixture of soil, concrete, water, and other aggregates into the ICEBs. Another machine utilized is the vibration table. When making paving slabs, material is placed into a mold which is then placed on the vibration table which vibrates air bubbles to the surface in order to limit discontinuity in the slab. These machines have many bushings and bearings that need to be replaced in order to work efficiently.

The direct sponsor and main stakeholder is Geoffrey Wheeler, the founding member of the CVBT. Our goal is to design, prototype, and test a single, free-sitting bench top frame that can perform both tests as well as the task of pressing bushing and bearings from the BP8 Block Press and the VT4 Vibration Table.

Sponsor Background

The CVBT began when the founder, Geoffrey Wheeler, saw market potential in some of the poorest regions of Thailand for a better roofing system for buildings in the smaller communities. Mr. Wheeler began designing what is now a world famous roof system, and he didn't stop there. The CVBT has designed and currently manufactures Interlocking Compressed Earth Blocks (ICEB), as well as ornamental paving slabs. To further develop the ICEBs and paving slabs, as well as to ensure that applicable building standards are met, the CVBT performs two separate tests. Currently, a less developed machine is used to perform these tests, which is why our group has been given the task to design a new one that better meets their requirements.

Objectives

We will design and build a single machine that is capable of conducting both the destructive and nondestructive tests, as well as removing and installing bushings and bearings from the BP8 Block Press and VT4 Vibration Table. The machine will be designed such that both hydraulic bottle-jacks, the 20-ton and 1.5-5 ton, can be used in the machine, and can easily be installed and removed. The machine will be appropriately sized for use on a raised work-bench table and will have a target weight of 50 kg.

In order to ensure that the final solution meets the project demands, Quality Function Deployment (QFD) was used. The full QFD is shown in **Appendix A**. In order for the reader to understand the significance of the QFD, a short description is provided below.

Quality Function Deployment is a tool used to:

- Connect customer requirements to engineering specifications.
- Determine which requirements and specifications are most important to the success of the project.
- Determine relationships between individual engineering specifications.
- Determine how well the current solution addresses the need.
- Compare the current solution to competing products.

Among other things, these help the engineer determine which aspects of the design to focus on specifically, and identify areas that need the most improvement.

Based on the QFD for this project, the team identified three engineering specifications as most critical to the design. These were the specifications that had the highest "weight" (shown near the bottom of the diagram), and therefore the most importance to the project. They are listed and briefly explained below.

1. Structural Material/Strength of Frame

The press must have the ability to withstand a range of forces for many uses, and over an extended period of time. The machine must be relatively low cost and be easily

replicated in Thailand. These requirements are all directly related to the frame of the machine and the material with which it is built.

2. Appropriate Dimensions

This specification refers to the size of the final product. The machine must be small enough to sit on a workbench, but must be large enough to fit an ICEB, a paving slab, and any equipment that must have a bearing or bushing removed or installed. Because one of the most important requirements is that a single frame accommodates all of these differently sized objects, the dimensions of the press immediately become a high priority.

3. Component Layout

This term refers to the manner in which the various components of the press (low range jack, high range jack, load rods, etc.) are arranged. For instance, one of the design requirements is that the machine can easily be reconfigured in order to perform various tests. This means that all of the machine's necessary components can readily be switched. The most important components being considered are described below:

- **Hydraulic Jacks:** The hydraulic jacks are used to apply the force to the test specimen. It must be easy for the operator to switch between the large and the small jack.
- **Press Plate:** The press plate will be pushed against the ICEB in order to execute the compression test
- **Load Rods:** The load rods are used to support the paving slabs during the bending test.

The layout of these components is critical to the ease of use of the machine.

The remaining engineering specifications, as well as how they will be achieved, are summarized in **Table 1** on the following page. Note that all of the engineering specifications are important to the project, and that the order of the list does not reflect priority. All targets that can be quantified have been, and others have been narrowed down to be as precise as possible.

Table 1. Engineering Specifications

Spec. #	Parameter Description	Requirement or Target	Tolerance	Risk*	Compliance**
1	Strength of Material	400MPa	Min.	L	A
2	Dimensions of Press	45 cm wide press workspace	Min.	M	A, T, I
3	Weight	50 kg = 110 lbf	Target	L	A, T
4	Corrosion Protection	Paint / Powder Coating	N/A	L	S
5	Manufacturing Procedure	Able to manufacture with limited machining tools: manual lathe, shapers, milling machine, SMAW welding, standard non-CNC machines	N/A	M	T, S
6	Tolerances	Achievable with limited machinery	Max = 0.001 in	M	A, T
7	Strength of Frame	Withstand 20 ton jack forces	Max.	M	A, T
8	Rigidity of Press Plate	Maximum deflection of 1/40 of the span	Max.	M	A, T, I, S
9	Component Layout	High Accessibility	N/A	M	A, T, S
10	Attachment of Jack to Frame	Removable Fasteners	N/A	M	T, S

* H: High Risk

M: Medium Risk

L: Low Risk

** Indicates how the team will ensure that the specification has been met:

A: Analysis

T: Testing

S: Similarity to Existing Designs

I: Inspection

CHAPTER 2: Background

This section contains information about the background research that was conducted prior to beginning the design of the product. This includes information on existing products, applicable standards, and any pertinent patents.

Existing Products

Current compression testers on the market are expensive, delicate, lab grade instruments. It is not plausible for the CVBT to buy and use a specialized compression tester since they are essentially overkill for what is needed and are much too expensive. The CVBT is in need of a low cost, robust alternative that can be manufactured from the locally available materials with the available tools. Some technologies used in current compression testers may be applicable and adapted to our design as far as how the load is actually applied to the block, how the block is supported, and what testing procedures are used. Along with compression and bending testing, the machine will also be required to have the ability to press bearings and bushings in order to service the compressed earth block press. Currently there are many models of hydraulic presses on the market. These presses are used to press fit parts such as bushings, bearings, bearing races, and other general parts that need pressing. Design attributes on these presses may be applicable to meet some of the requirements of our project.

Applicable Standards

Standards for concrete compression testing, ASTM C39 and ASTM C78, are applicable to our project. Although these codes apply to testing cylindrical samples of concrete, which is different from the compressed earth blocks, the general ideas behind the procedures were taken into account when generating concepts. These codes were pointed out to us by Dr. Dan Jansen, chair of the Civil and Environmental Engineering department at Cal Poly State University, who stressed the importance of compression testing procedure. A few important points taken from our meeting with Dr. Jansen focused on factors such as test platform deflection and contact flatness. These factors along with many other testing procedures influenced our decisions made during the design process. There are also codes that apply specifically to the interlocking compressed earth blocks (ICEB). African Regional Standards ARS CEB NF 1R, 2R, and 3R and Thai Industrial Standard TIS 378-2531 give required specs for the blocks and paving slabs. These test procedures and standards were also considered during design.

Patent Searches

Patent searches on similar ideas to the compression tester and hydraulic press yielded multiple patents, although the general idea of a hydraulic press is not patented. Most of the patents relating to presses are specialized, such as presses used for a specific molding function. Other related patents are listed in **Appendix B**. No general principles or designs that are intended to be used in our design have been patented.

CHAPTER 3: Design Development

After several sessions of idea generation and brainstorming, our team decided that two separate functions of the shop press compression tester needed to be conceptualized.

1. Top Frame and Slider
2. Bearing/Bushing Tool Attachment

These functions, along with our concepts, were developed as follows:

Top Frame and Slider Concepts

Concept 1: Four Poled Model

This model is similar to the CVBT's existing compression tester. It consists of a base plate, top plate, and press plate, all supported via the four support rods. The press plate slides vertically on the four rods, and is supported by two springs that are connected to the top plate. The springs hold the press plate off the bottom plate in order to allow a worker to place and position equipment into the frame that will have bearings or bushings pushed. The hydraulic jack is placed on top of the press plate. The object to be pressed is placed on top of the bottom plate, and the hydraulic jack is extended in order to lower the press plate onto the object.

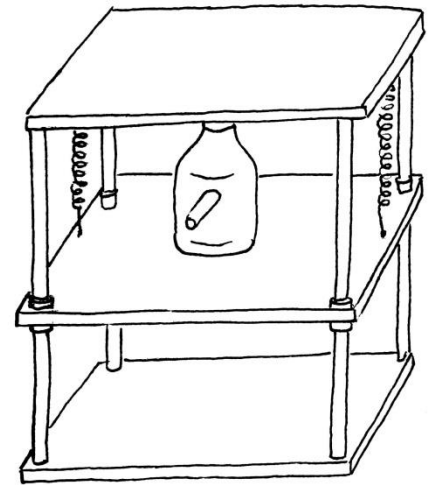

Figure 1 Four Poled Model.

Concept 2: H-Frame with I-Beam Structural Members

This model is constructed of I-beams, arranged in an H-frame configuration. The press plate slides vertically on the I-beams, guided by C-channels. The press plate is held up by two springs that are also attached to the upper I-beam. The hydraulic jack is placed between the press plate and the upper I-beam. The object to be pressed is placed on the lower I-beam and the hydraulic jack is extended in order to bring the press plate into contact with the object.

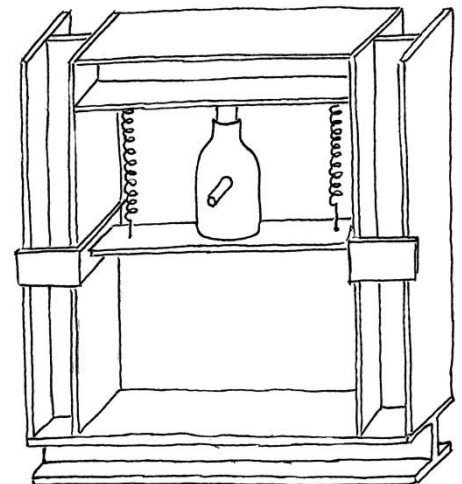

Figure 2 H-Frame and I-Beam Model.

Concept 3: H-Frame with C-Channel Structural Members

This model is identical to the previous model, but each of the vertical structural members is replaced with a C-channel.

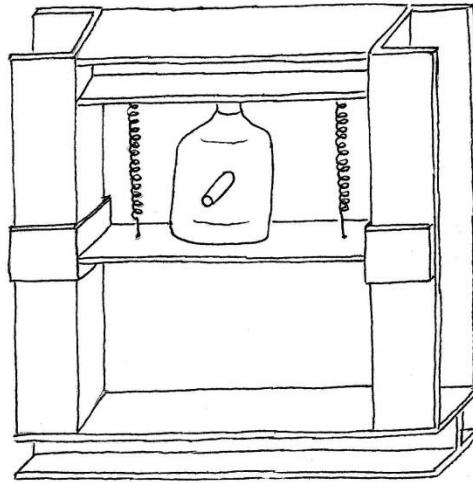

Figure 3 H-Frame with C-channel Model.

Concept 4: Hydraulic Jack on Bottom

This model is structurally similar to Concept 3, but the hydraulic jack is placed beneath the press plate instead of on top. The press plate still slides on the frame and is guided by two C-channels, but now rests on top of the hydraulic jack instead of being supported by springs. To conduct a test or push a bearing, the object is placed on top of the press plate, and the jack is raised in order to compress the object between the upper I-beam and the press plate. This model also has feet on either side to help with balance.

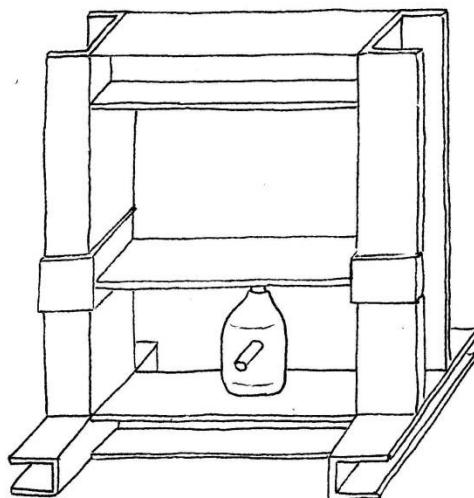

Figure 4 Hydraulic Jack on Bottom Model.

Top Bearing/Bushing Tool Attachment Concepts

As the Pugh and weighted decision matrices show (see next section), the team considered six different tool attachment options. The following concepts include only the top three ideas.

Concept 1: Recessed Magnet

The main focus of this concept is to achieve a quick interchange of tools. There are two holes drilled into the center of the upper I-beam, one smaller and within the first hole. This would allow for a magnet to be placed inside of the smaller hole, recessed just enough to avoid any contact between the magnet and whichever tool was inserted into the larger hole. The magnetic force would hold the tool in place, but would also allow a single person to remove it with ease.

Concept 2: Threaded Hole in I-beam

In order for this concept to work, the tool would have to be attached to a flat plate, which would then have two through holes drilled in it. These two holes would line up with two tapped holes in the bottom flange of the upper I-beam. The user would hold the tool and plate in place, start the bolts into the tapped holes by hand, and then tighten the bolts slightly with a wrench to assure correct positioning of the tool.

Concept 3: Through Hole in I-beam with Nut and Bolt

This concept is very similar to Concept 2 above. The only difference is that the holes in the bottom flange of the top I-beam are through holes rather than tapped holes. As opposed to threading bolts in to the I-beam, nuts and bolts would be used to secure the tool and plate to the I-beam.

Selection

A defined selection process was necessary to determine which of the conceptual ideas would best solve the problem. In selecting a final concept, several tools were used:

1. Physical Models
2. Pugh Matrices
3. Weighted Decision Matrices

Each of these tools is discussed in detail below.

Physical Models:

Physical models of each concept were built using posterboard and hot glue. The models helped the team to visualize how each concept would look, operate, and be constructed, and can be seen below in **Figure 5**.

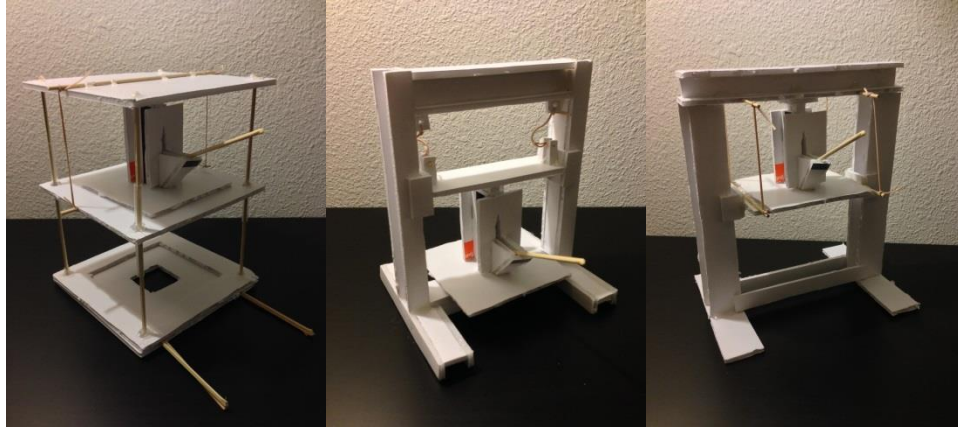

Figure 5 Models for concepts 1, 2, and 4 (left to right).

Pugh Matrices:

A Pugh matrix is used to compare competing conceptual ideas by assessing how well each concept satisfies the problem requirements. The Pugh matrix is not quantitative, and is used primarily to rule out unfeasible concepts as well as spur the generation of new concept ideas.

A Pugh matrix was completed for three concept categories:

1. Frame
2. Sliding Mechanism
3. Tool Attachment

The Pugh matrix for each of these categories is shown in **Appendix E**. The Pugh matrix gave a general indication of which ideas seemed to better satisfy the problem requirements, but the team did not discard any ideas until completing the weighted decision matrices (see below).

The Pugh matrix for the frame design yielded an additional concept: the idea of placing the hydraulic jack underneath the press plate instead of on top. This concept eventually was selected as part of the final concept.

Weighted Decision Matrices:

Weighted decision matrices are used to compare competing concepts by quantifying how well each one satisfies the design requirements. Unlike a Pugh matrix, a weighted decision matrix assigned a weight factor to each requirement, thereby giving a better idea of how well a concept addresses the most important requirements. A weighted decision matrix was

completed for each of the Pugh matrices, and can be seen in **Appendix F**. A concept which received a higher score is more favorable. The results from each category of matrix are discussed below.

Frame:

This decision matrix determined which of the frame concepts is most appropriate for the project. Based on the decision matrix, it is clear that the best concept is the H-style frame with C-channel structural members and the hydraulic jack placed on the bottom. The “weighted satisfaction”, which is an indication of how well the particular feature satisfies a particular requirement, highlights the areas in which this design excels. This concept as a whole will be cheaper than the other options due to the reduced cost of C-channels compared to I-beams, as well as because it is not necessary to buy springs. This design also contains the least amount of material, which will make it lighter than its competition. It will also be simpler to both make and operate, because there are no springs to be installed, removed, or maintained.

Sliding Mechanism:

This decision matrix compared the concepts for the press plate sliding mechanism. Based on the decision matrix for the sliding mechanism, the best choice for a sliding mechanism is a C-channel type component that can fit around the outside of the structural members. This design is superior to the alternative concepts due to its simplicity, ability to limit unwanted motion, and accessibility (for maintenance). This design is also much easier to construct because it does not require any modifications to the frame design.

Tool Attachment:

This decision matrix focused on methods of attaching a tool to the frame that is capable of pushing bearings and bushings. Based on the matrix, Concept 3 was chosen for the final concept. This method allows a user to easily remove or install the tool attachment quickly and effectively. The idea will be easy to implement because it requires limited machining, and eliminates the need to tap the holes in the I-beam.

The next section discusses how these decisions were combined into one final concept.

Preliminary Final Concept

For the final concept, the team compiled the best features from each stage of the selection process. Based on this process, the team chose Concept 4 from the “Frame and Slider Concepts” and Concept 3 from the “Tool Attachment Concepts” to implement in the next phase of the project. A solid model of the chosen design can be seen below in **Figure 6** in both the compression test and bearing pushing configurations.

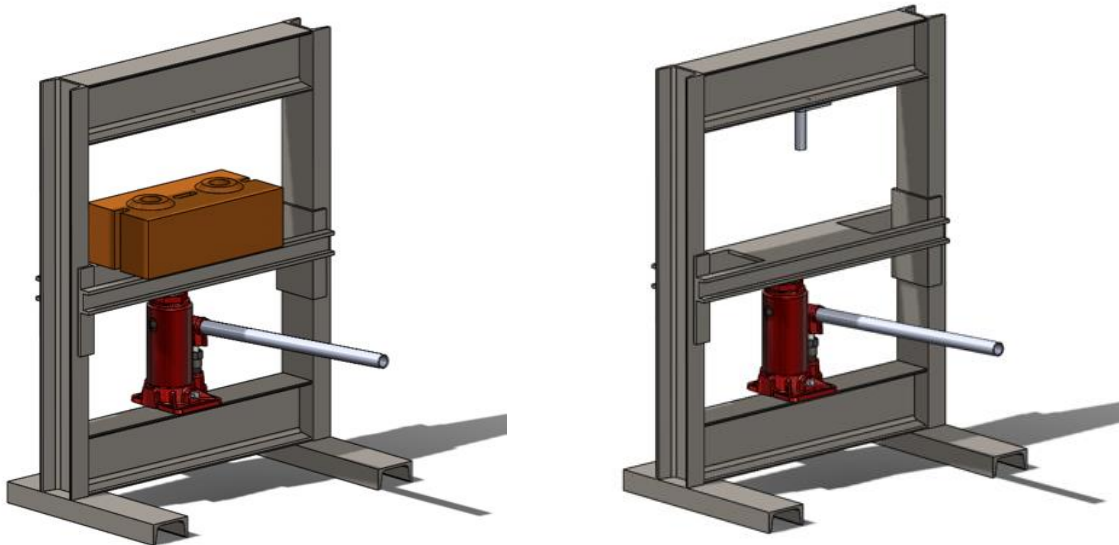

Figure 6 Machine in compression test (left) and bearing pushing (right) configuration.

After assembling this preliminary final concept, the design was modified many times in order to better satisfy the design requirements. These changes are discussed in detail in the next section.

CHAPTER 4: Description of Final Design

This section contains detailed information about the final design. Design changes from the preliminary concept, the finalized design, failure mode analysis, final design analysis, the manufacturing plan, and the cost analysis are all discussed. Detailed engineering drawings are attached in **Appendix L**.

Design Changes

After selecting the final concept, many features of the machine were added or modified in order to better satisfy the customer and strength requirements. The diagram of **Figure 7** indicates elements of the final concept design that have been changed for the final design. An explanation of these changes, as well as pictures of the modified design, is given below.

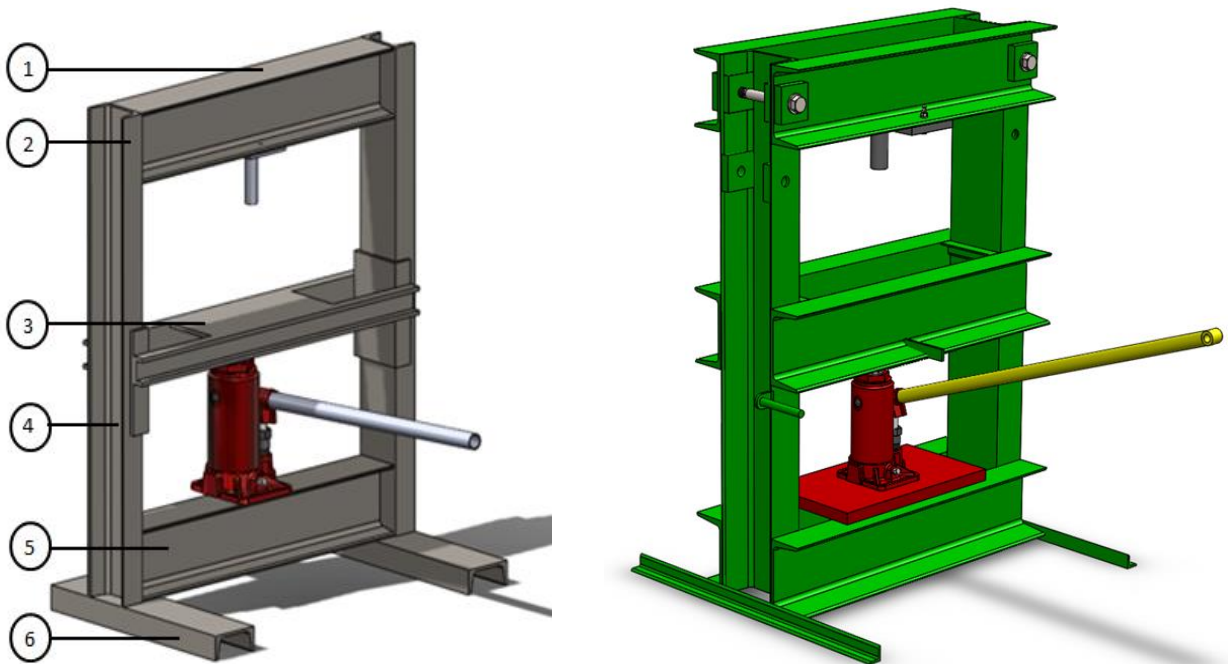

Figure 7 Design changes from preliminary concept to final design.

1) Top Beam:

For the final design, the top beam, formerly an I-beam (as shown in the left side of **Figure 7**), was replaced with two C-channels (see right side of **Figure 7**). This was done in order to reduce the number of different materials that must be purchased, as well as to better enable the machine to become adjustable (see next paragraph).

2) Adjustable Machine Height:

In order to better meet the needs of the CVBT, the design of the press was augmented such that the height of the upper beam can be adjusted. The new design is shown in **Figure 8**. This creates more space to be created between the top beam and the press plate, which allows the machine to push/press bearings and bushings out of larger objects. This adds functionality to the machine, since it increases the range of devices that can be serviced. The adjustability mechanism also allows the upper beams, as well as the sliding press plate, to be removed completely from the frame of the machine. This not only makes it easier to perform maintenance on the machine (cleaning, greasing, painting, etc.), but also allows a user to transport the machine in three pieces rather than one.

In order to make the machine adjustable, a mechanism for pinning the upper beam (now consisting of two C-channels) to the vertical supports was created. Through holes were added to the upper beams for the bolts to fit through, and two sets of holes (one upper set and one lower set) were also added to each of the vertical members, allowing the top beams to be installed in either the upper or lower configuration. Details on the design of the adjustability mechanism are given in the Final Design section.

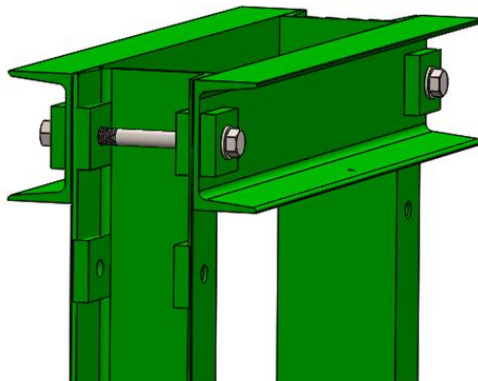

Figure 8 Frame adjustability mechanism.

3) Sliding Press Plate:

For the final design, the sliding press plate was modified from the configuration shown in the preliminary concept of **Figure 7** to consist of two short C-channel sections, with a steel plate and several angle irons welded to the beams, as seen below the final design of **Figure 7**. This was done for several reasons. First, this again lessens the number of different sized materials that must be ordered since the C-channel and angle iron are used elsewhere in the frame. Second, this configuration offers more stability for the plate as it travels up and downwards with the jack due to the area that is available to guide the plate. Most importantly, this design creates space for bearings or bushings to fall into as they are pushed out of a piece of equipment.

4) Hydraulic Jack Recompression Mechanism:

As the original concept for the machine did not include any mechanism for re-compressing the hydraulic jack once it had been extended, a means of accomplishing this was added to the final design, as shown in **Figure 9**. It is strenuous for a worker to apply enough force to recompress the jack when it is positioned on a table. This mechanism will allow the worker to easily return the hydraulic jack to its original position without the need to remove the jack from the frame and place it on the ground. A detailed description of the fabrication and operation of this mechanism is included in the Finalized Design section of this report.

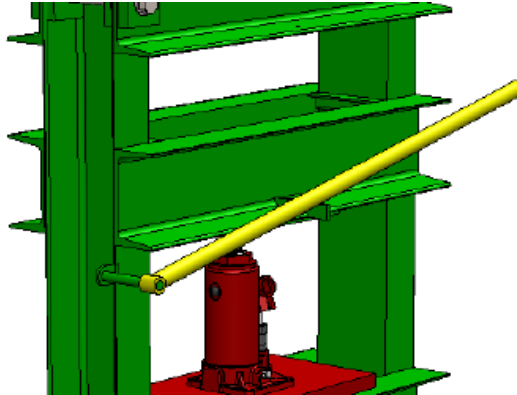

Figure 9 Implementation of the hydraulic jack recompression mechanism.

5) Lower Beam:

Like the upper I-beam, the lower I-beam was changed to two C-channels. The C-channels continue to provide adequate strength to the frame while simplifying the number of materials that are required to manufacture the press.

6) Feet:

In order to save weight, the C-channel feet were replaced with steel angle irons. The angle irons provide the same ability to balance the machine while remaining significantly lighter than the C-channels. Although the addition of the angle irons adds a new item to the BOM, the weight savings made it a good choice.

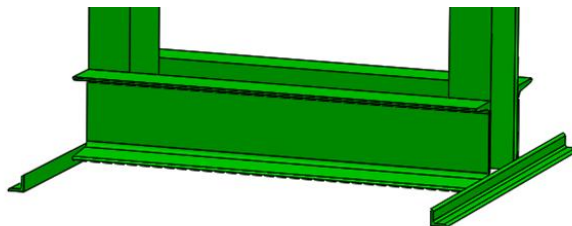

Figure 10 Angle iron feet- previously C-channels.

Finalized Design

The final design of the press can be broken up into five subsystems:

1. Frame
2. Sliding Press Plate
3. Bearing Pushing Attachment
4. Frame Adjustability Mechanism
5. Hydraulic Jack Recompression Mechanism

The following sections describe in detail each of these subsystems. The analysis of the press is discussed in the following section.

Frame:

The function of the frame is to support the sliding press plate and provide a rigid structure that the bottle jacks can apply a load against. As **Figure 11** shows, the majority of the frame is constructed from six lengths of 125x65 mm A-36 steel C-channel. Two of the C-channels are oriented vertically, forming the columns that support the upper beams and acting as a guide for the sliding press plate. The other four C-channels are oriented horizontally, acting as structural cross members for the frame. The frame also contains two feet, made from 25x25 mm angle iron, which serve to keep the press balanced.



Figure 11 Finalized frame configuration.

The lower C-channels are secured to the vertical members by weld beads. The precise configuration of the welds, as well as validating calculations, are discussed in the Analysis section. The upper C-channels are secured to the vertical members with two bolts via the Frame Adjustability Mechanism. Further details on this mechanism are given in the Frame Adjustability Mechanism section below.

Sliding Press Plate:

Aside from the hydraulic jack, the sliding press plate is the only moving component in the assembly. The press plate acts as the connection between the hydraulic jack and the work specimen and also forms a stable surface for the specimen to sit on. The press plate moves vertically as the hydraulic jack is extended or compressed, moving the work specimen at the same time.

As shown in **Figure 12**, the press plate consists of two lengths of C-channel connected by two pieces of angle iron, and joined on the bottom by a steel plate. Like the other structural members, the C-channels are 125x65 mm A-36 steel. The angle iron members are of the same type as those that comprise the feet, and are 25x25 mm. The steel plate is 200x200 mm and 12.7 mm thick and is welded to the bottom of the C-channels that make up the slider. The purpose of this steel plate is to act as a contact point for the hydraulic jack, transmitting the force from the jack to the sliding plate and pushing the mechanism upwards.

As the plate moves up and down with the jack, the C-channels and angle irons act as guides, keeping the plate aligned with the frame as it slides.

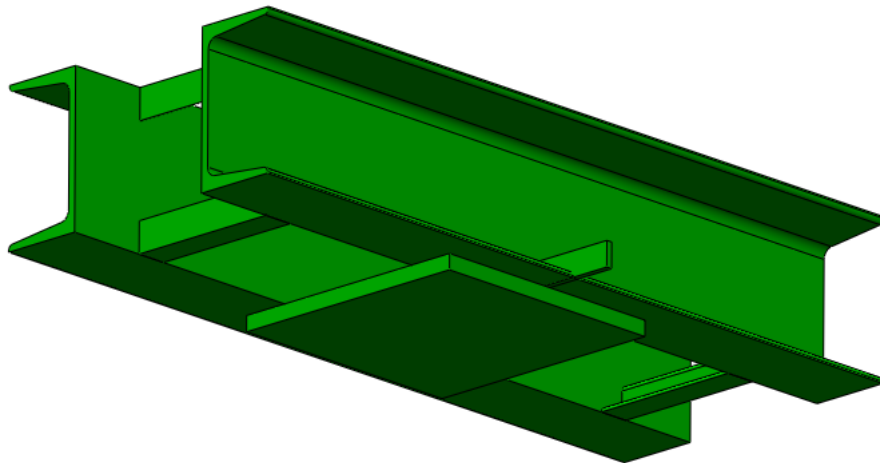

Figure 12 Final sliding press plate design. Includes angle irons, steel contact plate and jack recompression tab.

Bearing Pushing Attachment:

As shown below, in order to push or press bearings and bushings, an additional tool attachment must be installed. Due to the variety of bearing and bushing sizes that the machine will service, specific pushing tools have not been designed. Rather, the mechanism has been designed, and the CVBT can easily insert any size tool into the design. Throughout the design, the actual tool has been modeled as a solid steel circular rod.

For the tool attachment, the chosen pushing tool will be connected to a flat plate, which will have two holes drilled in it. To install the tool in the frame, bolts will be inserted via the through holes in the flat plate, as well as through two more through holes which are drilled in the upper beams. This allows the entire attachment to be fixed to the upper C-channels, and can be seen in **Figure 13**. The circular rod will be welded permanently to the flat plate to maximize strength and minimize deflection as a load is applied. The flat plate and rod are shown in **Figure 14**.

The tool is attached to the frame with two 6 mm bolts. No analysis was completed in sizing these bolts due to the fact that they bear essentially no load. Once the pushing tool is in contact with the part being serviced, it is in compression against the upper beam. All the force being applied to the pushing tool will be transmitted into the upper beam, leaving the bolts with no load. At the most, the bolts may experience a small shear force due to a slightly misaligned force being applied, and the 6 mm Class 10.9 bolts are more than capable of handling this small shear stress.

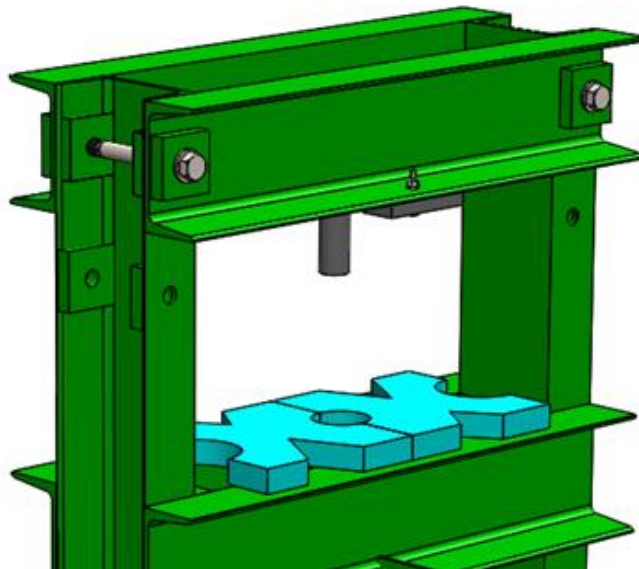

Figure 13 Machine in bearing pressing configuration.

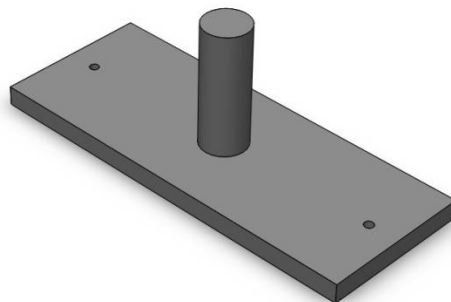

Figure 14 Bearing pressing tool attachment- rod and flat plate.

Frame Adjustability Mechanism:

The ability to adjust the frame is one of the most important features that was added to the final design. This mechanism allows the upper beams to be switched between two different positions, thereby changing the height of the machine and the amount of space between the upper beams and the press plate. A simple, removable bolt is used to anchor each side of the upper beams to the vertical members. The bolts are M14 x 200 mm Class 10.9 steel bolts, and anchor the upper beams to the vertical members. A picture of the adjustability mechanism is shown in **Figure 15**.

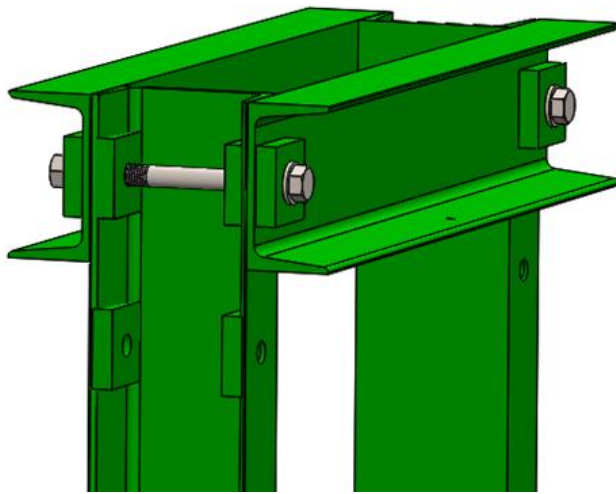

Figure 15 Doublers, shown added to the vertical members and upper beams.

Originally, two bolts on each side were used to fix the upper C-channels to the rest of the frame. This, however, caused a large reactionary moment in each bolt group, necessitating larger bolts (20.8 mm) than would fit in the given configuration. In order to resolve this issue, the double bolt configuration was changed to a single bolt. This allowed a properly sized bolt to be installed in each side, and also simplified the process of reconfiguring the height of the machine. After further analysis, the new bolt size was found to be 14 mm. The calculation for the bolt sizing can be found in **Appendix K**.

By changing the bolt pattern, each upper beam became a simply supported beam. In order to compensate for the larger moment that develops in a simply supported beam, the size of the C-channel was increased.

The concept of using a solid steel rod in place of this bolt was also considered. This idea was decided against due to its inability to keep the horizontal C-channels of the upper beam in contact with the vertical C-channels at all times. As an iteration of this single solid rod idea, it was considered to use two solid rods; one above and one below the upper beam to provide a tighter fit. Ultimately, however, this was abandoned for the same reason. The single bolt offers rigidity to the frame and ensures that the top C-channels cannot fall away from the vertical C-channels.

Some of the most critical areas of the adjustability mechanism are the through holes that are installed in the C-channels. Due to the configuration, significant bearing stresses are developed in these areas. In order to thicken the wall thickness of the C-channels to the point that they will not deform, thick plates (referred to as “doubblers”) were added to each hole. The doublers consist of 16 mm steel plate which are welded to each C-channel around the holes. In order to allow bolts to be inserted, they also have through holes drilled in them.

One of the most important considerations in the creation of this mechanism was the factor of safety on the bolt. By using a smaller factor of safety for the bolt than for the C-channels and doublers, it is ensured that the bolts will shear off before the frame deforms. This way, the least expensive and easiest component to replace will fail if the machine experiences greater loads than what it was designed for.

Hydraulic Jack Recompression Mechanism

This mechanism allows the user to return the hydraulic jack to the lowest position without needing to remove the jack from the frame. As shown in **Figure 16**, the mechanism consists of two simple tabs and a rod. The first tab is welded to the left vertical C-channel, out of the way of the sliding press plate. Welded to this tab at 90 degrees is a small solid steel rod that will be used as a pivot point. Another tab is welded to the middle of the lower C-channel on the sliding press plate. This tab will act as the force application area to compress the bottle jack.

The bottle jack handle, usually used to operate the jack, will be modified by welding a piece of circular tubing to one end that has the same inside diameter as the outside diameter of the solid steel rod that is welded to the frame. As shown in **Figure 16**, the central axis of this tubing is perpendicular to the axis of the jack handle. To operate the recompression mechanism, a user will remove the handle from the bottle jack, install it to the frame by slipping the added tubing over the solid rod, and then using the handle as a lever to push against the recompression tab. The jack handle will act as a lever, transmitting the force that the user applies into recompressing the jack.

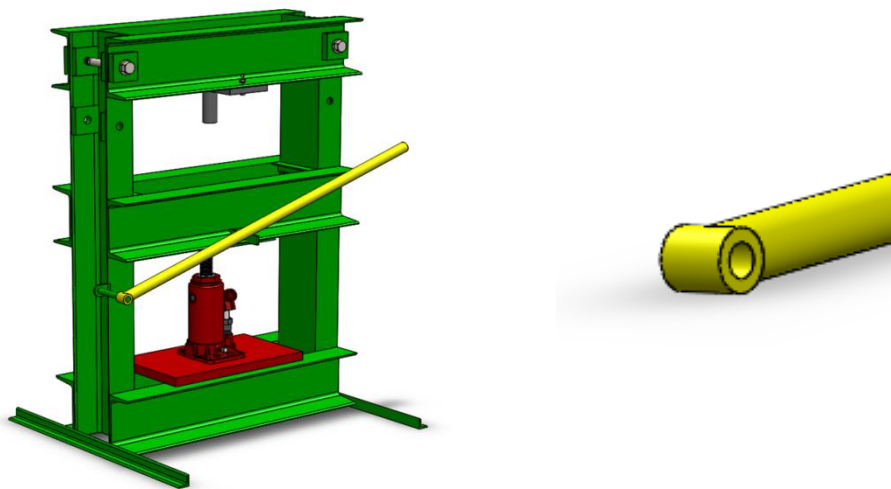

Figure 16 Machine configured for jack recompression (left) and compression handle (right).

Failure Mode Analysis

Previous to completing the analysis of the final design, a Design Failure Mode and Effect Analysis (DFMEA) was completed in order to highlight particularly critical areas. The DFMEA was used to identify potential design flaws or safety issues. The full analysis is shown in **Appendix I**, but the most important aspects are highlighted below.

The failure mode analysis indicated several areas of concern:

1. Bending of the upper and lower beams
2. Welds breaking

Based on the findings, much of the detailed analyses was focused on properly designing the upper and lower beams, and properly specifying the welds. The main causes for these issues revolve around defective material, faulty welds, and improper use of the machine. Because the design team has no control over the weld or material quality, all effort was put into properly sizing the beams and components such that they can withstand any range of loads they may encounter. This was accomplished by taking the worst case scenario, a 20-ton point load on the frame, and sizing each component based on this case. This is the most extreme case that the machine could ever experience, and is therefore useful in creating a final product that is capable of withstanding the operating conditions.

The team also completed a Safety Checklist for the machine, which is shown in **Appendix G**.

Final Design Analysis

In order to appropriately size the machine's components, calculations were completed to verify the strength and safety of each part. The calculations involved six separate analyses:

1. Frame
2. Sliding Press Plate
3. Tool Attachment
4. Bolts
5. Bearing Stress
6. Welds

Each of these analyses is discussed below.

I. Frame Analysis

As shown in **Figure 17**, the frame of the machine consists primarily of sections of steel C-channels. In order to simplify the procurement of materials, the entire frame is constructed out of a single size of C-channel. To choose the smallest acceptable size of C-channel, each section of the frame was analyzed to determine where the largest stresses are encountered, and how large the C-channel must be at this point.



Figure 17 Final frame design, constructed of C-channels and angle iron.

The frame analysis was broken into two components based on the two loading criteria: axial and bending. The two vertical C-channels are loaded axially, while the four horizontal C-channels are loaded in bending. Because the larger hydraulic jack is capable of exerting a 20 ton force, the beam analyses was completed for a 20 ton point load. This is the most conservative case, as the actual loading should not be nearly this large.

C-Channels in Bending:

Within the frame, all of the horizontal C-channels, two on the top and two on the bottom, are in bending. Although the upper and lower sets of C-channels are loaded in the same way, they are joined to the rest of the frame in a different manner, and thus are modeled differently.

Upper Beams:

Because the upper C-channels are fixed only by a single bolt on each side, they can be modeled as simply supported. **Figure 18** depicts how the beam was modeled.

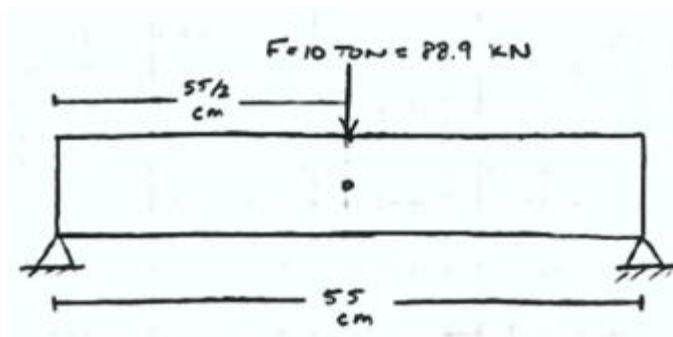

Figure 18. Upper beams modeled as simply supported.

Because the upper beams are identical in the way that they are fastened and loaded, the load on each beam is assumed to be exactly half of the total load. After analyzing a single, simply supported C-channel for a 10 ton point load, it was determined that the 125x65 mm C-channel is sufficient for this application.

The maximum stress in the beam was calculated using the von Mises equivalent stress method, which takes both the normal and shear stresses into account. To determine the location in the beam which experiences the most stress, three critical areas were analyzed. These three areas are identified in **Figure 19**.

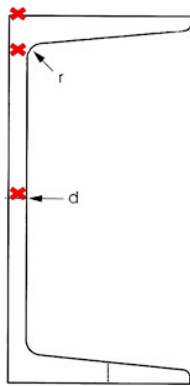

Figure 19 Critical stress areas in C-channel cross section

The maximum stress resulted in the middle location, where the beam transitions from flange to web. With a beam this size, the beam experiences a maximum equivalent stress of 242.7 MPa and a maximum deflection of just 0.36 mm. This stress remains below the yield strength of 250 MPa, and the deflection represents less than 1/1500 of the span.

It is obvious that the factor of safety for this beam extremely small. In analyzing the frame, however, a major focus was to keep deflection at an acceptable level. Analysis proves that the deflection is very small and that the beam will withstand the largest point load that will ever be applied. Taking into account that the beam should never encounter a force nearly this large, and in the interest of choosing appropriately sized beams that will not unnecessarily raise the weight of the machine, the 125x65 mm beam was taken as acceptable.

Appendix K shows the detailed calculations for the sizing of the beam and the deflection analysis.

Lower Beams:

Like the upper beams, the lower C-channels were analyzed for a 20-ton point load, with 10 tons acting on the center of each beam. Since these C-channels are welded to the frame, the beam was modeled as fixed. **Figure 20** shows the model that was used for the analysis.

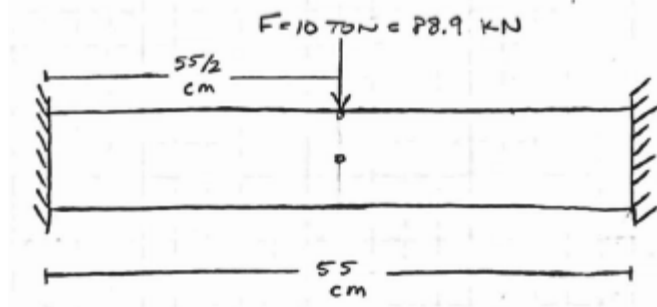

Figure 20. Lower fixed beam model.

The maximum moment that is developed in a fixed beam is half as large as the moment that is developed in a simply supported beam. Because of this, no further analysis was necessary to verify that the 125x65 mm C-channels are sufficient for the lower beams, since it has already been proved that they are sufficient for the simply supported upper beams.

C-Channels Loaded Axially:

As mentioned above, the frame's two vertical members experience a nearly purely axial load. Since the 20 ton load is applied to the center of the middle beams, each vertical C-channel experiences a reaction load of 10 tons.

Again, calculations were used to verify that a 125x65 mm C-channel is capable of safely withstanding these axial loads. After completing the analysis, it was shown that a beam of this size is adequate, as the normal stresses of 52 MPa that are developed in the beams remain well below the yield strength of 250 MPa.

Because a 125x65 mm beam proved sufficient for all three components of the frame, this beam was selected for use in the final design.

II. Sliding Press Plate Analysis

The analysis for the sliding press plate was used to verify that 125x65 mm C-channels are acceptable to use in this configuration and to determine the required size of the steel plate that the jack pushes against.

C-Channels:

The sliding press plate is used as a spacer between the jack and the block and the work piece which will be compressed. The C-channels are not fixed at either end, meaning that they experience only a shear force. The frame analysis proved that the 125x65 mm C-channel is sufficient to bear the shear force from the 10-ton point load, and this beam is also therefore acceptable for this application. In reality, the beam will see much less than a 10-ton point load, as the force from the jack is distributed across the steel plate that is welded to the bottom of the slider.

Steel Plate:

The flat steel plate that is welded to the bottom of the C-channels can be modeled as a 20 cm long fixed beam. Initially the plate was designed to be 1.27 cm thick ($\frac{1}{2}$ "), since this is the same plate used for all other plate in the design. After analysis, it was discovered that a 20mm thick flat steel plate is necessary to withstand the 20 ton point load the jack will apply to it. The hand calculations for this are attached in **Appendix K**. In order to minimize the different types of material needed to build the press, gussets made from the same plate will be welded to the back of the plate in order to support the load.

II. Bolt Analysis

The bolt analysis was used to determine the necessary size of the bolts for the frame adjustability mechanism.

As shown in **Figure 21**, the top beams of the press are secured to the rest of the frame via two large bolts. Analysis of the bolts and the loading configuration was conducted in order to choose an appropriate size for the bolts.

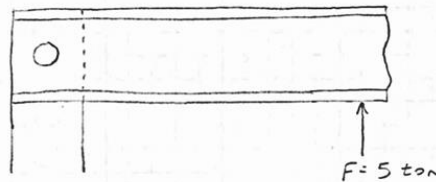

Figure 21 Analysis model for shear in bolts.

As previously mentioned, the top beam can be modeled as a simply supported beam because the bolts on each end do not support a moment. Modeling the beam this way requires that only the direct shear of the bolts be evaluated. The entire force felt by the top beam is 20 tons and it is assumed that this load is distributed equally to the two C-channels that make up this top beam. This means that each C-channel only sees a 10-ton load. When evaluating the bolts, it is easiest to look at just one bolt, going through one C-channel, on one side of the press. With this simplification, the force that the bolt encounters is 5 tons, as shown in **Figure 21** above.

After the analysis, it was determined that a M14 x 200mm Class 10.9 bolt is capable of withstanding the loads. The hand calculations for this analysis are shown in **Appendix K**.

III. Bearing Stress Analysis

Due to the manner in which the upper beams are connected to the vertical members, bearing stresses are developed around the through holes in each C-channel. During the 20 ton point loading case, each channel wall is loaded with 5 tons over the bolt contact area. A calculation was first performed in order to check if the channel wall at the through hole was thick enough to prevent plastic deformation. The calculation concluded that the channel walls were not thick enough. In order to minimize the bearing stress in these locations, the wall thickness

needed to be increased. A calculation was then performed to determine how thick the wall at the through holes needed to be. It was determined that the wall thickness would need to be a minimum of 22.25 mm in order to not deform. To achieve this thickness, doubling plates will have to be added to the inside of the vertical C-channels and the outside of the horizontal C-channels. A diagram of this can be seen in **Figure 22**. Adding these plates will ensure that the frame will not deform under the 20 ton point load.

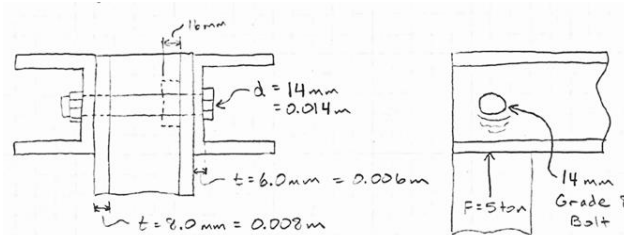

Figure 22 Analytical schematic for bearing stresses.

IV. Weld Analysis

Drawings CT-011, CT-021, and CT-041 in **Appendix L** show in detail what joints are going to be welded. Some of these welds, such as those on the tool attachment, sliding press plate, and feet, undergo a relatively small amount of stress. These welds mainly serve the purpose of holding the component in place. However, the weld joints on the base c-channels and the frame wall doubling plates undergo a large amount of stress and require analysis in order to correctly size the welds.

To analyze the base c-channel welds, a 20-ton point load was again used as a worst case scenario. This scenario would result in a 10 ton point load on each beam. As shown in **Figure 23**, each weld group is loaded in torsion. The weld pattern would consist of a full 4 sided configuration. Using these parameters, it was determined that a 12mm fillet weld is sufficient, allowing a factor of safety of two.

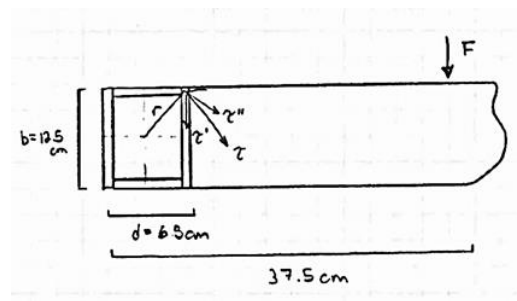

Figure 23 Weld analysis model.

The frame wall doubling plates would also undergo a large amount of shear stress transferred from the 14mm mounting bolts. Each plate is under a 5 ton load, creating a shear stress in the welds. Using a weld path fully around the plate, it was determined that the weld size needed was only a 2 mm fillet. In turn, we will use an 8 mm fillet weld to allow for a factor of safety of four. This calculation can be seen in **Appendix K**.

Final Cost Breakdown

Due to the ability of the prototype to be manufactured entirely within Cal Poly machine shops, all of the cost comes from the price of materials. **Table 2** shows the final cost of the prototype, broken down into components.

Table 2. Cost analysis for building prototype with standard components.

Item	Cost
5 x 1 7/8" x .325 A36 C-Channel	\$180
1/2" Steel Plate	\$90
1/2" HR Round Steel Stock	\$14
1.5"x1.5" Angle Iron	\$18
5/8-18 x 8" Grade 8 Bolts and Nuts	\$10
1/4-20 x 1 1/2 " Grade 5 Bolts and Wing Nuts	\$4
20-ton Bottle Jack	\$70
Hydraulic Pressure Gauge	\$50
1/4" NPT 90 Degree Elbow	\$55
1/4" Male-to-Male NPT Nipple	\$50
Paint Supplies	\$10
Total	\$551

This cost falls just above the target budget of \$500.

CHAPTER 5: Product Realization

Throughout the development of our design, we made every effort to ensure that the press would be able to be manufactured with the limited tooling available at the CVBT. Because of this goal, we were able to use a fairly constrained set of tooling to build our prototype. Tools used during prototype manufacturing included:

- Horizontal band saw
- Angle grinder
- MIG welder
- C-clamps
- Framing square
- Tape measure
- Drill press

To begin manufacturing our prototype, we created a top level flow chart of our manufacturing process, shown below in **Figure 24**.

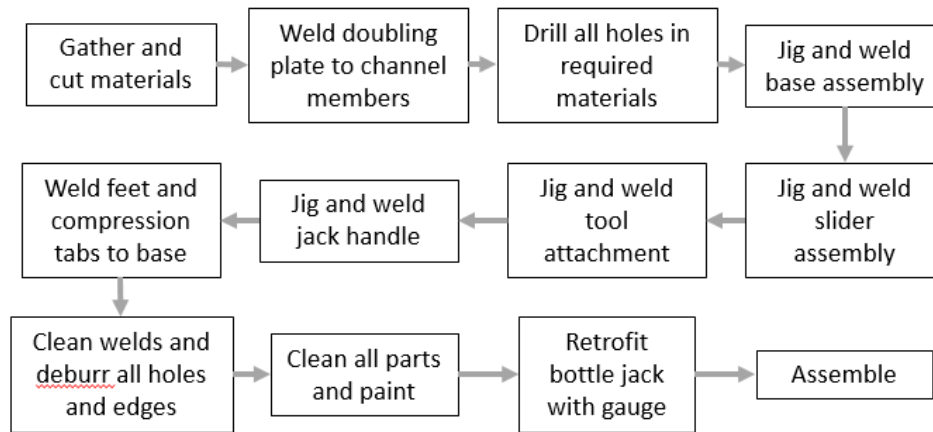

Figure 24. Manufacturing process flow chart.

This flowchart served as a guide to make sure that each part of the manufacturing process was completed in the correct order. The order of the processes was chosen to minimize time and difficulty of fabrication. For example, it was decided to weld the frame wall doubling plates onto the C-channel flanges before drilling any of the holes. This decision removed 12 drilling processes from our plan since the hole was in turn being drilled in the doubling plate and the channel at the same time. Since that hole is larger than $\frac{1}{2}$ " diameter with a $\frac{3}{4}$ " depth, a considerable amount of time was saved. After the flowchart was optimized, we began our fabrication.

I. Gathering and Preparing Materials

Once we had purchased our materials, we verified that each raw material was the correct dimensions. Since we purchased the standard equivalents of the metric materials specified in our drawings, there were some minor differences. The differences were not drastic enough to constitute changes to the drawings for the prototype.

In order to prepare the materials to be welded and fixed, each piece had to be cut to lengths specified by our engineering drawings shown in **Appendix L**. All of the pieces were cut to size with a horizontal band saw as shown in **Figure 25**.



Figure 25. Cutting C-channel members with horizontal band saw.

II. Weld doubler plates to C-channels

Once the materials were cut, we were ready to begin welding the frame wall doubling plates into place. Since the filler metal rods used in shielded metal arc welding (SMAW) were unavailable at the Cal Poly mechanical engineering shop, metal inert gas welding (MIG) was used. The doubler plates were ground down with an angle grinder to fit the contour of the C-channel flange and web. The plates were then tack welded in place per the engineering drawings as shown in **Figure 26**. Once the placement was verified, full round fillet welds were placed around the plates, ensuring the fillet was sized according to the drawings. In some cases, multiple beads were overlapped in order to meet the fillet size requirement.

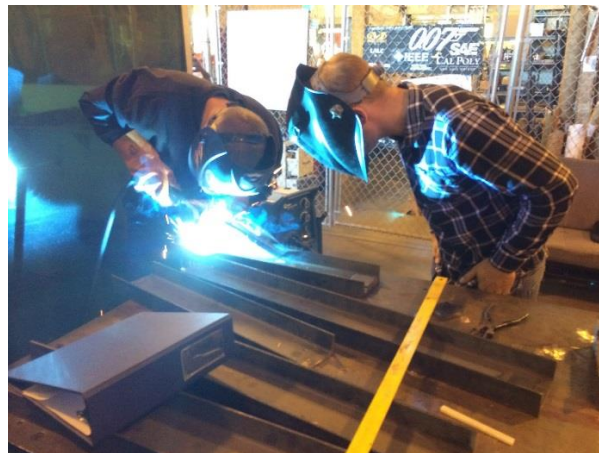

Figure 26. Welding frame wall doubling plates to c-channels.

III. Drilling holes

A drill press was used to drill all of the holes where mounting hardware is used. The hole locations were carefully measured using a tape measure and marked with a center punch. With the hole locations marked, each piece was separately clamped into the drill press and the hole was made. The drill speed was tuned for best performance determined by metal chip formation. **Figure 27** shows coolant being added to the work piece while a hole is drilled in the C-channel flange.



Figure 27. Cooling bit and work piece while drilling holes in c-channel.

It would have been ideal to have a drill bit long enough to drill both sides of the c-channel flange at once in order to ensure hole alignment, but a bit of that length was not available.

IV. Welding base assembly

When fabricating the base assembly, it was crucial that we had correct alignment. In order to achieve the tolerances specified on our drawing, a flat steel table was used along with c clamps. The vertical members were placed on the table, parallel to each other. The first horizontal member was then placed on top of the parallel members in the correct placement. A framers square was then used to ensure that the horizontal member was perpendicular to both vertical members. Once the placement was correct, the members held in place with two c clamps. The second horizontal member was placed at the top of the vertical members only to be used as a reference to ensure the assembly was square. This set up can be seen in **Figure 28**.



Figure 28. Tack welding base assembly.

Once the first horizontal member was tack welded to the vertical members, the part was turned over to allow for the attachment of the second horizontal member. Once both members were tack welded in place, measurements were taken to ensure the part matched our drawings.

A temporary piece of steel was tack welded to the top of the vertical c-channels before full welds were placed at the joins. The purpose of this temporary piece of steel was to keep the vertical members in the correct position as the metal was heated and cooled during welding. Once the welds were complete, the work piece was allowed to cool and the temporary steel member was removed. Unfortunately, internal stresses accumulated during the expansion and contraction of the metal during welding. Once the temporary member was removed, the vertical members sprung out slightly, putting the top of the vertical members about $\frac{1}{4}$ " out of tolerance. If a furnace was available, the work piece could have been annealed before the temporary member was removed, allowing the internal stresses to be removed.

V. Welding slider assembly

The slider assembly was manufactured similarly to the base assembly. A flat steel table was used along with a framers square to ensure the pieces were square to each other. Careful measurement was taken in order to ensure the slider would allow for proper clearance between the slider and the base. The slider was tack welded together and fit tested in the frame as shown in **Figure 29**. The clearance specified in the drawings proved to be sufficient.



Figure 29. Checking fit of tack welded slider assembly.

VI. Welding tool attachment

The tool attachment consists of steel round stock welded to a plate. The framer's square was used to make sure the round stock was perpendicular to the surface of the plate while it was tack welded into place. Once tack welded, a full fillet weld was placed to hold the part together.

VII. Welding jack handle

In order to incorporate the jack recompression function, the jack handle needed to be modified per our engineering drawings. A small section of the end of the jack handle was cut and welded at a 90 degree angle at the end of the handle. The handle was also lengthened with additional tubing.

VIII. Welding feet and recompression tabs

The feet and recompression tabs were then added to the frame. The feet were placed on the flat table against the frame and welded into place as shown in **Figure 30**. Contours on the compression tabs were made using an angle grinder.



Figure 30. Aligning feet with frame.

IX. Cleaning Welds and Deburring

Once the welding was complete, the parts were cleaned by removing any weld slag. The angle grinder with an abrasive flap disk was used in order to remove the slag around the welds. All sharp edges and burrs were also removed from all parts.

X. Painting

In order to prevent the press from rusting, multiple coats of Rust-oleum protective enamel, shown in the left side of **Figure 31**, were applied to the press.

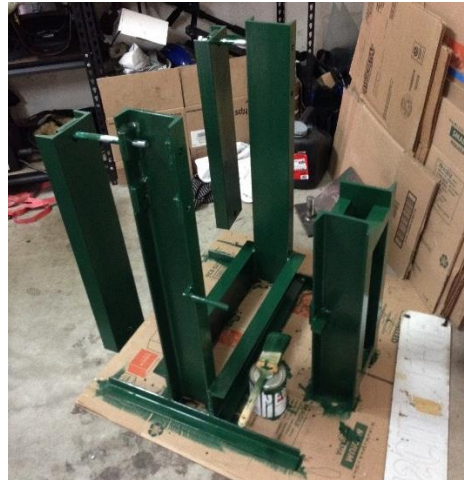

Figure 31. (Left) Rust-oleum protective enamel, hunter green, 7738730. (Right) First coat of paint drying.

Before the paint was applied, the parts were degreased and cleaned. Each coat was applied and left to cure for 10 hours, as shown in the right side of **Figure 31**.

XI. Retrofit jack with gauge

In addition to designing and fabricating the press frame, it was necessary to retrofit our bottle jack with a hydraulic pressure gauge in order to take measurements for testing. We determined that we could drill and tap the bottle jack in order to fit a gauge with a few NPT fittings.

The jack was first disassembled per the manufacturer's manual. Once the jack was apart, the base was placed in a drill press in order to drill a hole which would be tapped for a $\frac{1}{4}$ " NPT fitting, as shown in **Figure 32**. The hole for the $\frac{1}{4}$ " hole was drilled at a depth of 1", which was then followed by a $\frac{1}{8}$ " hole at an additional 1" depth.



Figure 32. Hole for $\frac{1}{4}$ " NPT tap being drilled.

The base was then rotated 90 degrees and a second $\frac{1}{8}$ " hole was drilled in the position that would intersect the horizontal $\frac{1}{8}$ " hole (see **Figure 33**) The hole depth was just enough to connect to the other drilled hole. This hole essentially gives the $\frac{1}{4}$ " NPT fitting access to the high pressure cavity inside the bottle jack.



Figure 33. Tapping high pressure access hole.

Once we ensured the holes were connected, the $\frac{1}{4}$ " NPT threads were cut, as shown in the left side of **Figure 34**. After the threads were cut to the correct depth, all metal shavings were cleaned from the jack with compressed air and a magnet.



Figure 34. (Left) Cutting $\frac{1}{4}$ " NPT threads for hydraulic fittings. (Right) Cleaning shavings from jack with compressed air.

Finally, the jack was reassembled. The fittings were then inserted, using Teflon tape to seal the threads, as seen in **Figure 35**.



Figure 35. Jack with 15000 psi rated fittings.

The jack was then filled with oil, all air was bled from the system, and the gauge was installed to the 90 degree elbow fitting. Lastly, the jack was painted to protect areas where metal was exposed during machining.

XII. Assembly

The press was assembled per the engineering drawings with the assistance of a ratchet strap used to correct for the movement of the vertical channels. Once the cross members were bolted in place the ratchet strap could be removed. The final assembly is shown in **Figure 36**.



Figure 36. Final assembly of press.

Differences from Planned Design

The only part of our prototype that is different than our design is the base assembly upright member position. The two vertical members are not within the parallel tolerance specified. This is due to the movement after welding and removing the temporary member. In the end, the distance between the top of these beams is about $\frac{1}{4}$ " larger than specified. The prototype still functions as intended, but is slightly more difficult to disassemble.

Recommendations for Future Manufacturing

In order to get a more accurate base assembly, we recommend using a jig which initially angles the vertical members inward towards each other. Therefore, once the welds are complete, the members will pull apart and be closer to parallel. We recommend finding the correct jig angle empirically. Otherwise, if a furnace is available, the base assembly could be manufactured identically to our methods with the exception of annealing the part before the temporary member is removed.

CHAPTER 6: Design Verification

In order to validate the final design, a Design Verification Plan and Report (DVP&R) was completed. **Table 3** summarizes the tests that were conducted in order to validate the design, followed by more detailed descriptions of each test and the results found upon completion of said tests. The full DVP&R is shown in **Appendix J**.

Table 3. Design verification plan.

#	Test Name	Test Description	Acceptance Criteria
1	Basic Functionality	Verify ability to complete functions: 1. Compression test of ICEB 2. Bending test of paving slab 3. Install/remove bushing/bearing	Successful completion of each task
2	Maximum Loading	Verify that press can withstand 20-ton point load	No plastic deformation of any component
3	Weight	Ensure that the frame meets the weight requirement	Weight less than 80 kg
4	Slider Reliability	Ensure that slider works properly under normal working conditions	Slides freely and does not affect test results
5	Frame Stability	Ensure the machine is stable and will not tip during normal use	Does not tip while performing all three functions
6	Tool Attachment Interchangeability	Verify that tool can be installed/removed easily	One person can install/remove tool in one minute
7	Frame Adjustability	Verify that frame can easily be switched between configurations	Two people can reconfigure frame in 5 minutes
8	Jack Recompression	Verify that the Recompression Mechanism is capable of compressing the bottle jacks	One person can recompress 20 ton jack

A description of each of the tests outlined in **Table 3**, as well as the results, is given below.

1. Basic Functionality Test

As stated in the Objectives section, the goal of the project is to create a machine capable of conducting destructive compression tests of ICEBs, conducting non-destructive bending tests on paving slabs, and removing or installing bushings and bearings from various pieces of equipment. The Basic Functionality Test will verify that the machine is capable of reliably completing each of these activities.

In order to test the machine, each of the three activities were recreated. Two ICEBs were obtained from the Manufacturing Department at Cal Poly to perform the destructive tests and examine the overall functionality of the press. From information provided by our sponsor it was known that the common pressures seen while compressing an ICEB range from 2-5 MPa. The target of the test was to successfully compress an ICEB and reach the specified range before the block failed. The process was performed twice to ensure that the press would work repeatedly. The process of the destructive compression tests performed on the two ICEBs can be seen in **Figures 37** and **38** below.



Figure 37. (Left) Press arranged in compression testing configuration. (Right) ICEB beginning to fail at corner.



Figure 38. Total failure of ICEB.

The two ICEBs that were tested reached 2.05 and 2.35 MPa respectively before fracturing, which is on the lower end of the desired pressure range. This demonstrated that the press functioned as intended and provided accurate test results. As the compression test was conducted, the team inspected the press thoroughly to ensure that all components were functioning as expected and there were no visible flaws.

The non-destructive bending test of the paving slabs was not performed because a paving slab was not available for testing. It can be extrapolated from the ICEB testing results that the paving slab test would be completed successfully due to the fact that the paving slabs require much less pressure than the ICEBs to test and the press accommodated the higher pressures of the ICEB tests without issue.

To test the bearing/bushing installation and removal, a bearing was pressed into an axle-housing that was procured separately. The press performed adequately as a standard shop press and pushed the bearing in without issue.

2. Maximum Loading Test

The sponsor specified that a 20-ton bottle jack will be used to operate the press. As a safety precaution he required that the press be able to withstand a 20-ton point load in the case that an operator used the machine wrong and ran the jack up to its full capacity. To test this, two plates of ½ inch thick mild steel were stood on end, side by side. The jack was then ran up to a pressure of 10.8 ksi, which corresponds to an exerted force of 20 tons, or 40,000 lbs. Pictures of the test can be seen in **Figure 39** below.



Figure 39. View of 20-ton point load testing configuration (left and center) and jack gauge during the test (right).

The bottle jack was slowly worked up to 10.8 ksi, with stops at 1500 psi intervals in order to allow for thorough inspection of the press. The press was examined for any visible damage or large deformation of any component. Upon reaching the maximum pressure of 10.8 ksi, the press was left under this stress for 3 minutes while it was inspected closely. The only noted change was a very slight amount of elastic deformation of the top beams. The deformation was not measurable enough to be captured by a picture and provided no problems to the press functionality or structural integrity. The pressure was then slowly released off the jack and the steel plates removed. There was no plastic deformation of any component on the press. This ensures that the press can withstand the maximum load that the jack is capable of producing.

3. Weight Test

To test whether or not the final product meets the requirement for weight, the machine was weighed. The assembled machine, with all components (not including the hydraulic jack or ICEB compression plates) installed, weighs 87.5 kg, or about 193 lbs. The requirement was that the machine weighs less than 80 kg. Upon consulting with the sponsor, it was agreed upon that because the press can be disassembled into smaller components, the weight of the largest subsystem needed to be less than 80 kg; while the weight of the entire press could exceed 80 kg. A breakdown of the weight of each component can be seen in **Table 4** below.

Table 4. Results of weight test.

Component	Weight (kg)	Weight (lbf)
Top Beams	19.0	42.0
Sliding Press Plate	20.7	45.6
Frame	47.8	105.4
Complete Press	87.5	193.0

As can be seen in **Table 4** above, the weight of the largest component of the press is only 47.8 kg, which is much smaller than the maximum allowable weight of 80 kg.

4. Slider Reliability Test

This test was used to ensure that the sliding press plate functioned as expected and did not inhibit the functionality of the machine in any way. This test was conducted simultaneously to the Basic Functionality Test. The Sliding Press Plate was monitored very closely as the hydraulic bottle jack was extended and compressed. It was made sure that there was no binding or misalignment of the slider as it was worked through its full range of motion. No such issues were discovered, so the slider was decided to be reliable and non-inhibitive to data collection.

5. Frame Stability Test

A static calculation was performed using the dimensions of the press to find what the required force would be to tip the press over. It was found that it would take a 36.3 kg, or 80 lb, force applied at the press' highest point to tip it over. During normal operation the press does not see a tipping force even remotely close to this magnitude. The stability of the frame was tested during the Basic Functionality Test to ensure that at the maximum applied force to the jack handle, the press will still remain stable. As more pressure is applied to the block, the jack handle requires more force to make the jack continue moving up. Throughout the use of the press in any configuration, the force applied to the jack handle was never enough to cause the press to become unstable.

6. Tool Attachment Interchangeability Test

One requirement of the machine is that it can easily be reconfigured to be able to install or remove bushings and bearings. This test verified that one person can install/remove the Bearing Pressing Tool quickly and easily. To perform this test, a team member installed and then removed the Bearing Pressing Tool while being timed. It was found that both the removal and installation of the tool took approximately 35 seconds. This is well within the requirement of the tool being changed in under a minute. To ensure that this was a repeatable amount of time, each team member performed the test. The time to install/remove the tool did not change.

7. Frame Adjustability Test

This test was used to determine whether the frame is as easy to adjust as intended. For the test, two team members at a time were tasked with changing the height of the machine by moving the upper beams from the lower to the upper setting, or vice versa. This process was timed and then repeated with a different combination of team members to ensure the time to change was repeatable. The maximum allowable time to change the height configuration was 5 minutes. On average, the height change performed by two people took 3 minutes. This was well within the acceptable time frame.

8. Jack Recompression Test

The functionality of the jack recompression mechanism was tested repeatedly by each member of the team to ensure that it was efficient and easy to use. To do this, the jack was

pumped up and compressed many times. It was discovered that the recompression mechanism is not necessary when the ICEB and testing plates are sitting on the sliding press plate. The weight of the block and the two steel plates is enough to recompress the jack entirely. At any other time, the jack recompression mechanism needs to be used. By applying a small downward force to the lever arm, the user is easily capable of compressing the jack completely.

CHAPTER 7: Conclusions and Recommendations

After completing all the required tests on the press, it was determined that it was a successful prototype. The press was able to function properly during the destructive compression tests of the ICEBs and showed no signs of damage or alteration after experiencing the maximum point load case. All aspects of the design function how they were intended and contributed to an easy-to-use piece of machinery.

During the fabrication of the press, the team did not properly account for the amount of weld shrinkage at the base of the frame. As a result, the two vertical members pulled away from each other slightly upon cooling. A recommendation for future fabricators of this design would be to overcompensate for the amount of shrinkage to ensure that upon cooling the vertical members will be perfectly vertical.

Appendix B: Patent Search Results

A short patent search yielded many machines that are similar to the compression tester. However, each patent is also specifically geared toward a single, unique process. The patent numbers and a short description are listed in **Table 5** below.

Table 5. Patent search results

Patent No.	Title	Comments
EP 1837127 B1	"Tool for Tightening and Loosening Bearings, Bushings or Similar"	- Single use - Applicable only to bushings and bearings
CN 203110362 U	"Hydraulic Press"	- Electrically controlled - Used for mechanical maintenance
EP 0332420 A2	"A Hydraulic Press"	- Manually operated - Appears to be intended more for pushing and pulling bearings
WD 2005097480 A1	"A Hydraulic Press With Displaceable Plates"	- Used to mold an object by smashing it between two plates - Similar to compression test

Appendix C: Initial Design Requirements

Compression Tester – Shop Press

Required IP Agreement:

Anticipated number of students: 3



Background/Need

The Center for Vocational Building Technology (CVBT) was founded in 1991 to create new employment in Northeastern Thailand by promoting small-scale manufacture of building materials including interlocking compressed earth blocks (Rhino blocks), ornamental concrete paving slabs, and concrete roof tiles. These can replace imports to the region and help reduce the migration of workers to Bangkok or foreign countries. The CVBT designs tools, technologies, and products used for production and testing of building materials.

Strength testing concrete products has the benefits of: having confidence in the products, having certified products to market and reducing cement content. A press fit is required for some bushings and bearings in the villagers' production equipment. Currently the villagers test all the products using a test stand with hydraulic jacks. The test stand cannot install and remove bushings nor test 45 cm wide paving slabs.

Design Goals:

Design and fabricate a compression tester - shop press with the following characteristics:

- Economical
- Durable
- Simple to make (including appropriate tolerances) in Udon Thani, Thailand
- Made from materials available in Thailand
- Uses Masada MHB20 20 ton hydraulic jack (high range)
- Uses Masada NPD 1.5-5 telescoping bottle jack (low range)
- Can compression test compressed earth blocks up to size 15 x 30 x 10cm (contact area 388 sq-cm) to ARS level 3 loading, (3MPa).

- Can test bending strength of ornamental paving slabs of 45 cm width to Thai and British standards.
- Can remove and install bushings from BP8 block press.
- Can remove and install bearings from VT4 vibrating table.
- Four models: floor mounted and table mounted
- Simple to pack for shipping
- Analyze and specify part finishes and press fits for BP8 bushings and design a bushing installation and removal tool.

Output Goals:

- One press made with all accessories:
 - High range jack and gauge.
 - Low range jack and gauge.
 - Load rods for paving slabs
 - Load rod locators
 - Male block dowels for female cavities
- Solid models and drawings in Inventor format and on CVBT title block. PDFs
- Costed Bill of materials; Thai/English
- Processes, Equipment and tooling specified in detail; T/E
- Machine shops identified and evaluated
 - Requests for quotes returned
 - Work orders issued
- Proprietary agreements issued
- First articles checked
- Quality Assurance System Ready
 - Check sheets published; Thai/English
 - Test instructions published; T/E
 - Production run ID or date applied
- Marketing Materials Ready
 - Instruction sheet published: T/E
 - Logo applied to equipment
 - Crating designed
 - Ads published: print & web: T/E
 - Pricing issued T/E

Resources:

- BP8 at Cal Poly
- VT4 at Cal Poly
- A bearing removal tool exists for the VT4 vibrating table.
- Paving Slab Molds at Cal Poly
- Solid Model of VT4
- Solid Model of BP8
- Geoffrey Wheeler
- Inventor software
- AutoDesk Forum Community
- Witmongkolchai Machine Shop
- Danish Machine Shop
- Don Bosco Machine Shop

Here are some photos of our current block press tester.



Appendix D: Preliminary Calculations

PRELIMINARY CALCULATIONS:

I-BEAMS AT TOP AND BOTTOM OF FRAME WELL, AT A WORSE CASE SCENARIO, UNDERGO A 20 TON POINT LOAD

SCHEMATIC: MODEL AS A BEAM FIXED AT BOTH ENDS

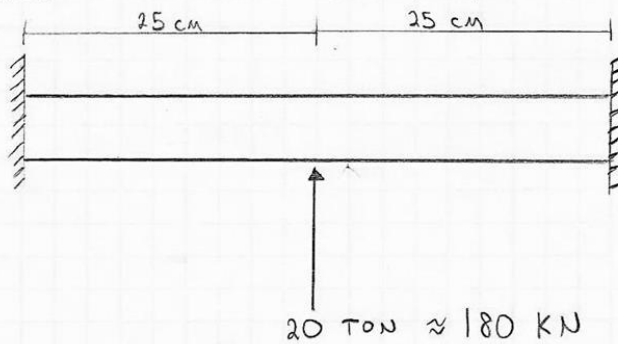

SHEAR DIAGRAM:

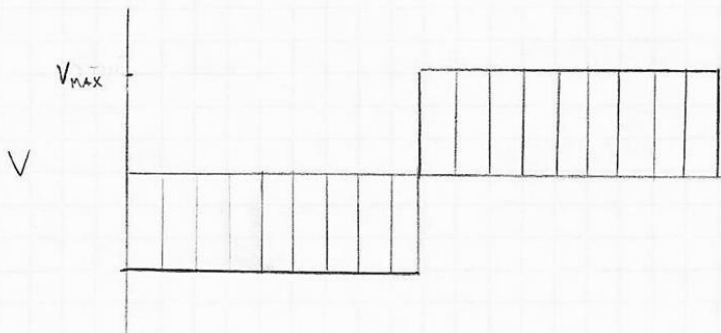

$$V_{MAX} = \frac{P}{2}$$

$$V_{MAX} = 10 \text{ TON}$$

$$V_{MAX} \approx 90 \text{ KN}$$

MOMENT DIAGRAM:

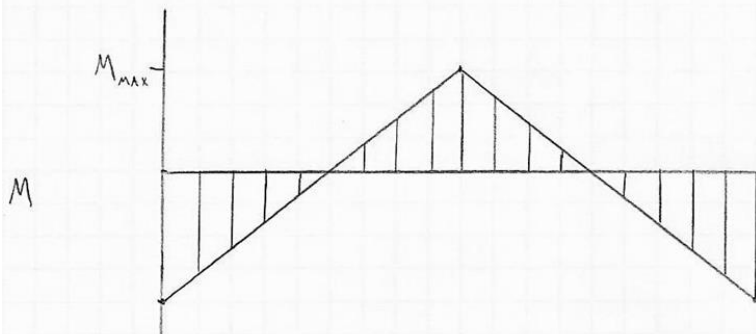

$$M_{MAX} = \frac{PL}{8}$$

$$M_{MAX} = \frac{(180 \text{ KN})(50 \text{ cm})}{8}$$

$$M_{MAX} = 1125 \text{ KN}\cdot\text{CM}$$

(CONT'D)

Appendix D: Preliminary Calculations Cont.

PRELIMINARY CALCULATIONS (CONT'D):

$$\frac{\sigma_y}{N} < \frac{M \cdot C}{I} \quad \frac{I}{C} = W$$

$N = 2$, FACTOR OF SAFETY

$W =$ SECTION MODULUS

$\sigma_{\text{yield}} = 250 \text{ MPa}$ (A36 STEEL)

$$W > \frac{M \cdot N}{\sigma_y}$$

$$W > \frac{(1125 \times 10^3 \text{ N} \cdot \text{cm}) (2) \left(\frac{1 \text{ m}}{100 \text{ cm}}\right)}{(250 \times 10^6 \text{ Pa})}$$

$$W > 9.0 \times 10^{-5} \text{ m}^3 \left(\frac{100^3 \text{ cm}^3}{1 \text{ m}^3}\right)$$

$$\underline{\underline{W > 90 \text{ cm}^3}}$$

BASED ON THIS, WE WILL CHOOSE AN I-BEAM WITH A SECTION MODULUS, W , GREATER THAN 90 cm^3 .

USE W-BEAM $100 \text{ mm} \times 100 \text{ mm} \times 19.3 \text{ kg/m}$.

Appendix E: Pugh Matrices

Pugh Matrix for Frame Design

Concept Criterion	Geoffrey's	Four poles	H-frame I beam with C-channel sliders	H-frame C- channel with rod sliders	H frame with C- channel and C-channel slider
	1	2	3	4	5
Single Free- sitting Bench Top Frame	D	+	+	+	+
Ability to compression test earth blocks		S	S	S	S
Ability to bend- test paving slabs		+	+	+	+
Ability to press bushings/bearings		+	+	+	+
Fits Masada 20- ton and 1.5-5 ton jack	A	S	S	S	S
Withstand jack forces		S	S	S	S
Economical		+	+	-	+
Durable		-	-	+	S
Simple to make in Thailand	T	-	-	-	S
Utilize materials available in Thailand		S	S	S	S
Easy to change configuration		+	-	-	S
Safe to operate		S	S	+	+
Quick to assemble	U	S	-	-	-
Quick to use		+	+	+	+
Easy and cheap to maintain		-	-	-	-
Weight		-	+	+	+
$\Sigma+$	M	+7	+6	+7	+7
$\Sigma-$		-6	-5	-5	-2
ΣS		6	5	4	7
$\Sigma+/-$		+1	+1	+2	+5

Appendix E: Pugh Matrices Cont.

Pugh Matrix for Sliding Mechanism

Concept / Criterion	C-channel outside frame	C-channel inside frame	Tab inside frame	Rod and slider	Wheels on outside of frame	
	1	2	3	4	5	6
Ease of installation and removal	D	S	+	-	-	
Smooth sliding		S	-	+	+	
Limits unwanted motion	A	S	-	+	+	
Durability		S	S	S	-	
Low Cost	T	+	+	-	-	
Simple to incorporate into frame		-	-	-	-	
Simple to make in Thailand	U	-	-	-	-	
Utilize materials available in Thailand		S	S	S	S	
Safe to operate	M	+	+	S	S	
Easy to lubricate /clean		-	-	S	-	
Weight		+	+	-	-	
$\Sigma+$		+3	+4	+2	+2	
$\Sigma-$		-3	-5	-5	-7	
ΣS		5	2	4	2	
$\Sigma+/-$		0	-1	-3	-5	

Appendix E: Pugh Matrices Cont.

Pugh Matrix for Tool Attachment

Concept	Recessed magnet	Guitar clasp	Pivoting threaded rod with nut	Pivoting L-bracket	Bolt plate to l-beam	Threaded hole
	1	2	3	4	5	6
Criterion						
Ease of installation and removal	D	-	-	S	-	-
Mounted strongly (so can't bend)		-	+	S	+	+
Rigid once mounted		A	-	+	S	+
Durability	-		-	-	S	S
Low Cost	-		S	S	+	+
Simple to incorporate into frame	T	-	-	-	S	+
Simple to make in Thailand		-	-	-	S	+
Utilize materials available in Thailand	U	-	S	+	+	+
Safe to operate	M	-	-	-	S	S
Quick interchange of tools		-	-	-	-	-
Weight		S	S	S	S	S
$\Sigma+$		+0	+2	+1	+4	+6
$\Sigma-$		-10	-6	-5	-2	-2
ΣS		1	3	5	5	3
$\Sigma+/-$		-10	-4	-4	+2	+4

Appendix F: Weighted Design Matrices

CONCEPT AREA: FRAME		Design Concepts							
Criteria	Weight	Four Pole Frame		H-frame (I-beam)		H-frame (C-channel) with jack on top		H frame (C-channel) with jack on bottom	
		Satisfaction	Weighted Satisfaction	Satisfaction	Weighted Satisfaction	Satisfaction	Weighted Satisfaction	Satisfaction	Weighted Satisfaction
Single Free-sitting Bench Top Frame	0.07	100	6.56	100	6.56	100	6.56	100	6.56
Ability to compression test earth blocks	0.11	100	11.48	100	11.48	100	11.48	100	11.48
Ability to bend-test paving slabs	0.11	100	10.66	100	10.66	100	10.66	100	10.66
Ability to press bushings/bearings	0.10	100	9.84	100	9.84	100	9.84	100	9.84
Fits Masada 20-ton and 1.5-5 ton jack	0.08	100	8.20	100	8.20	100	8.20	100	8.20
Withstand jack forces	0.12	100	12.30	100	12.30	100	12.30	100	12.30
Economical	0.05	50	2.46	70	3.44	75	3.69	90	4.43
Durable	0.06	75	4.30	75	4.30	75	4.30	85	4.88
Simple to make in Thailand	0.07	90	5.90	75	4.92	75	4.92	80	5.25
Utilize materials available in Thailand	0.07	100	7.38	90	6.64	90	6.64	90	6.64
Easy to change configuration	0.03	80	2.62	80	2.62	80	2.62	75	2.46
Safe to operate	0.02	50	0.82	75	1.23	75	1.23	80	1.31
Quick to assemble	0.01	90	0.74	60	0.49	60	0.49	75	0.61
Quick to use	0.03	90	2.95	90	2.95	90	2.95	90	2.95
Easy and cheap to maintain	0.01	90	0.74	80	0.66	80	0.66	85	0.70
Weight	0.07	25	1.64	65	4.26	75	4.92	80	5.25
Total:			88.57		90.53		91.43		93.48

CONCEPT AREA: SLIDING MECHANISM		Design Concepts							
Criteria	Weight	C-channel outside frame		C-channel inside frame		Tab inside frame		Rod and Slider	
		Satisfaction	Weighted Satisfaction	Satisfaction	Weighted Satisfaction	Satisfaction	Weighted Satisfaction	Satisfaction	Weighted Satisfaction
Ease of installation and removal	0.09	75	6.44	75	6.44	75	6.44	50	4.29
Smooth sliding	0.12	75	8.74	75	8.74	50	5.83	95	11.07
Limits unwanted motion	0.12	90	10.49	90	10.49	50	5.83	95	11.07
Durability	0.07	90	6.63	90	6.63	80	5.89	75	5.52
Low Cost	0.10	75	7.36	75	7.36	85	8.34	60	5.89
Simple to incorporate into frame	0.08	90	7.18	75	5.98	90	7.18	50	3.99
Simple to make in Thailand	0.09	75	6.44	70	6.01	90	7.73	60	5.15
Utilize materials available in Thailand	0.10	75	7.36	75	7.36	90	8.83	75	7.36
Safe to operate	0.09	90	7.73	75	6.44	75	6.44	75	6.44
Easy to lubricate/clean	0.09	90	7.73	75	6.44	75	6.44	65	5.58
Weight	0.07	75	5.52	75	5.52	75	5.52	75	5.52
Total:			81.63		77.42		74.48		71.90

CONCEPT AREA: TOOL ATTACHMENT		Design Concepts											
Criteria	Weight	Recessed Magnet		Guitar Clasp		Pivoting Threaded Rod with Nut		Pivoting L-Bracket		Bolt Plate to I-beam		Threaded Hole	
		Satisfaction	Weighted Satisfaction	Satisfaction	Weighted Satisfaction	Satisfaction	Weighted Satisfaction	Satisfaction	Weighted Satisfaction	Satisfaction	Weighted Satisfaction	Satisfaction	Weighted Satisfaction
Ease of installation and removal	0.13	100	12.70	75	9.52	80	10.16	90	11.43	75	9.52	90	11.43
Rigid once mounted	0.13	90	11.43	50	6.35	75	9.52	35	4.44	95	12.06	95	12.06
Durability	0.11	85	9.44	75	8.33	80	8.89	50	5.56	90	10.00	85	9.44
Low cost	0.11	75	8.33	65	7.22	80	8.89	85	9.44	90	10.00	90	10.00
Simple to incorporate into frame	0.11	85	9.44	65	7.22	70	7.78	75	8.33	90	10.00	85	9.44
Simple to make in Thailand	0.11	80	8.89	60	6.67	75	8.33	80	8.89	85	9.44	85	9.44
Utilize materials available in thailand	0.13	90	11.43	85	10.79	95	12.06	95	12.06	95	12.06	95	12.06
Safe to operate	0.10	95	9.05	90	8.57	85	8.10	25	2.38	90	8.57	90	8.57
Weight	0.08	80	6.35	85	6.75	75	5.95	75	5.95	70	5.56	75	5.95
Total:			87.06		71.43		79.68		68.49		87.22		88.41

Appendix G: Safety Checklist

SENIOR PROJECT CONCEPT DESIGN REVIEW HAZARD IDENTIFICATION CHECKLIST

- | Y | N | |
|--------------------------|--------------------------|---|
| x | <input type="checkbox"/> | Will any part of the design create hazardous revolving, reciprocating, shearing, punching, pressing, squeezing, drawing, cutting, rolling, mixing, or similar actions, including pinch points and shear points? |
| <input type="checkbox"/> | x | Can any part of the design undergo high accelerations/decelerations? |
| x | <input type="checkbox"/> | Will the system have any large moving masses or large forces? |
| <input type="checkbox"/> | x | Will the system produce a projectile? |
| x | <input type="checkbox"/> | Is it possible for the system to fall under gravity creating injury? |
| <input type="checkbox"/> | x | Will a user be exposed to overhanging weights as part of the design? |
| <input type="checkbox"/> | x | Will the system have any sharp edges? |
| <input type="checkbox"/> | x | Will the system have any ungrounded electrical systems? |
| <input type="checkbox"/> | x | Will there be any large batteries or electrical voltage in the system above 40 V (either AC or DC)? |
| x | <input type="checkbox"/> | Will there be any stored mechanical energy in the system such as flywheels, hanging weights or pressurized fluids? |
| <input type="checkbox"/> | x | Will the system produce high heat (>120°F) at any location? |
| <input type="checkbox"/> | x | Will there be any explosive or flammable liquids, gases, or dust as part of the system? |
| x | <input type="checkbox"/> | Will the user of the design be required to exert any abnormal effort or physical posture during the use of the design? |
| <input type="checkbox"/> | x | Will there be any materials known to be hazardous to humans involved in either the design or the manufacturing of the design? |
| <input type="checkbox"/> | x | Might the system generate high levels of noise? |
| x | <input type="checkbox"/> | Is the system easy to use unsafely? |
| x | <input type="checkbox"/> | Will the system be used in extreme environmental conditions such as fog, humidity, cold, high temperatures, etc...? |
| <input type="checkbox"/> | x | Are there any other potential hazards not listed above? If yes, please explain below. |

Appendix H: Gantt Chart

Because the Gantt chart is too large to fit in the Appendix, a screen shot of the chart is shown below.

	Task Mode	Task Name	Duration	Start	Finish	Predecessors
34	✚	▢ CAD model	9 days	Thu 4/17/14	Tue 4/29/14	30
35	✚	Solidworks models	6 days	Tue 4/22/14	Tue 4/29/14	
36	✚	BOM	4 days	Thu 4/17/14	Tue 4/22/14	
37	✚	Final Design Report	0 days	Fri 5/2/14	Fri 5/2/14	
38	✚	Final Design Report	14 days	Wed 4/30/14	Mon 5/19/14	34
39	✚	Order Parts	3 days	Tue 5/20/14	Thu 5/22/14	38
40	✚	Prepare End of Quarter Report	1 day	Thu 6/5/14	Thu 6/5/14	
41	✚	▢ Build Prototype	20 days	Mon 9/22/14	Fri 10/17/14	
42	✚	Order additional parts if needed	1 day	Mon 9/22/14	Mon 9/22/14	
43	✚	parts procurement	5 days	Mon 9/22/14	Fri 9/26/14	
44	✚	fabrication	15 days	Mon 9/29/14	Fri 10/17/14	43
45	✚	Prototype Completed	0 days	Fri 10/17/14	Fri 10/17/14	
46	✚	▢ Testing	11 days	Mon 10/20/14	Mon 11/3/14	41
47	✚	General functions testing	3 days	Mon 10/20/14	Wed 10/22/14	
48	✚	Strength testing	4 days	Wed 10/22/14	Mon 10/27/14	
49	✚	Block testing	3 days	Mon 10/27/14	Wed 10/29/14	
50	✚	Accuracy testing	3 days	Thu 10/30/14	Sun 11/2/14	
51	✚	testing reports	1 day	Mon 11/3/14	Mon 11/3/14	
52	✚	Senior Design Expo	0 days	Tue 11/11/14	Tue 11/11/14	
53	✚	▢ Senior Design Expo	9 days	Mon 11/10/14	Thu 11/20/14	46
54	✚	Prepare presentation for expo	2 days	Fri 11/14/14	Mon 11/17/14	
55	✚	Final Report	0 days	Fri 12/5/14	Fri 12/5/14	
56	✚	▢ Final Report	10 days	Mon 11/24/14	Fri 12/5/14	53
57	✚	Prepare Final report	10 days	Mon 11/24/14	Fri 12/5/14	

Appendix I: Design Failure Mode and Effect Analysis

Item / Function	Potential Failure Mode	Potential Effect(s) of Failure	Sev	Potential Cause(s) / Mechanism(s) of Failure	Occur	Crit	Recommended Action(s)	Target Completion Date	Action Results			
									Actions Taken	Sev	Occur	Crit
I-beam (top and bottom)	Bend	-Sliding mechanism would bind -Testing results inaccurate -Tool attachment wont fit	7	-Improper use -Fatigue -Defective material	6	42	-Recommend training before use -Design for high number of cycles	4/17/2014	-Train users -Perform design analysis for fatigue	7	4	28
	Shear off of C-channels	Frame would not be usable	8	-Improper use -Fatigue -Defective material	5	40	-Recommend training before use -Design for high number of cycles	4/17/2014	-Train users -Perform design analysis for fatigue	8	3	24
	Welds break/crack	Frame would not be usable	8	-Improper use -Fatigue -Poor weld quality	5	40	-Recommend training before use -Design for high number of cycles -Design weld sizes to prevent failure	4/17/2014	-Train users -Perform design analysis -Perform weld size calculations	8	3	24
	Corrode	Could reduce frame structural integrity	4	Protective coating wears off	7	28	-Provide coating over entire frame	Senior project expo	-Paint frame	3	2	6
Vertical C-channels	Axial plastic deformation	-Could cause sliding mechanism binding -Testing results inaccurate	8	-Improper use -Fatigue -Defective material	6	48	-Recommend training before use -Design for high number of cycles	4/17/2014	-Train users -Perform design analysis for fatigue	8	2	16
	Bend	Sliding mechanism would bind Testing results inaccurate	8	-Improper use -Fatigue -Defective material	4	32	-Recommend training before use -Design for high number of cycles	4/17/2014	-Train users -Perform design analysis for fatigue	8	2	16

	Welds break/crack	Frame would not be usable	8	-Improper use -Fatigue -Poor weld quality	5	40	-Recommend training before use -Design for high number of cycles -Design weld sizes to prevent failure	4/17/2014	-Train users -Perform design analysis -Perform weld size calculations	8	3	24
	Corrode	Could reduce frame structural integrity	4	Protective coating wears off	7	28	-Provide coating over entire	Senior project expo	-Paint frame	3	2	6
C-channel Legs	Bend	Frame would be unstable	7	-Improper use -Fatigue -Defective material	5	35	-Recommend training before use -Design for high number of cycles	4/17/2014	-Train users -Perform design analysis for fatigue	7	2	14
	Welds break/crack	Frame would not be usable	8	-Improper use -Fatigue -Poor weld quality	5	40	-Recommend training before use -Design for high number of cycles -Design weld sizes to prevent failure	4/17/2014	-Train users -Perform design analysis -Perform weld size calculations	8	3	24
	Corrode	Could reduce frame structural integrity	4	Protective coating wears off	7	28	-Provide corrosion resistant coating	Senior project expo	-Paint frame	3	2	6
Sliding Press Plate	Bend	-Testing results inaccurate	7	-Improper use -Fatigue -Defective material	6	42	-Recommend training before use -Design for high number of cycles	4/17/2014	-Train users -Perform design analysis for fatigue	7	2	14
	Welds break/crack	Frame would not be usable	8	-Improper use -Fatigue -Poor weld quality	5	40	-Recommend training before use -Design for high number of cycles -Design weld sizes to prevent failure	4/17/2014	-Train users -Perform design analysis -Perform weld size calculations	8	4	32
	Bolts fail	Slider would not be usable	8	-Fatigue -Defective material	5	40	-Perform bolt size calculations -Replace broken bolt	4/17/2014	-Calculate necessary bolt sizes	8	2	16
	Binds up	-Test results would be inaccurate -Frame could be unusable	8	-Inadequately lubricated -Corrosion -Dirt between sliders -Bent components	5	40	-Properly lubricate slider -Provide corrosion resistant coating -Clean and re-lubricate when necessary	4/17/2014	-Lubricate slider -Paint sliding mechanisms -Perform maintenance regularly	8	4	32

	Jack deforms bottom	-Could cause sliding mechanism to bind -Block may not sit flush	7	-Improper use -Defective material	6	42	-Recommend training before use	4/17/2014	-Train users	6	1	6
Tool Attachment	Bend	Cause difficulty while pressing	7	-Improper use -Installed incorrectly -Defective material - Misalignment between part and tool	6	42	-Recommend training before use -Inspect tool after installation	4/17/2014	-Train users -Visually inspect tool after attachment	7	3	21
	Welds break/crack	Can't use for pressing	8	-Improper use -Fatigue -Poor weld quality	5	40	-Recommend training before use -Design for high number of cycles -Design weld sizes to prevent failure	4/17/2014	-Train users -Perform design analysis -Perform weld size calculations	8	4	32
	Bolts strip out	-Tool will fall out	7	-Improper use -Fatigue -Defective material	5	35	-Recommend training before use -Design for high number of cycles	4/17/2014	-Train users -Perform design analysis for fatigue	7	2	14
	Bolts fail	-Tool will fall out	7	-Fatigue	5	35	-Design for high number of cycles	4/17/2014	-Perform design analysis for fatigue	7	3	21
Entire Frame	Tips left/right	-Could damage components -Could injure user	9	- Earthquake -Improper use -Accident	6	54	-Recommend training before use -Provide stable base	4/17/2014	-Train users -Verify base is stable and strong	9	2	18
	Tips forward/backward	-Could damage components -Could injure user	9	- Earthquake -Improper use -Accident	6	54	-Recommend training before use -Provide stable base	4/17/2014	-Train users -Verify base is stable and strong	9	2	18
Bottle Jack	Jack fails	Unable to use system	8	-Defective jack -Fatigue	3	24	-Replace jack	N/A	-Replace jack	8	3	24

Appendix J: Design Verification Plan

Report Date:		5/2/2014	Sponsor	Geoffrey Wheeler			Component/Assembly
TEST PLAN							
Item No	Specification or Clause Reference	Test Description	Acceptance Criteria	SAMPLES TESTED		TIMING	
				Quantity	Type	Start date	Finish date
1	Functionality	Verify ability to complete functions: 1. Compression test ICEB 2. Bending test paving slab 3. Install/remove bearing/bushing	Successful completion of each task	1	P	10/20/2014	10/22/2014
2	Maximum Loading	Verify that press can withstand 20-ton point load	No plastic deformation of any component	1	P	10/20/2014	10/22/2014
3	Press Plate Rigidity	Verify that the press plate does not deflect more than 1/40 of its span	Must deflect less than 1/40 of span to pass	1	P	10/22/2014	10/27/2014
4	Weight	Ensure that frame meets weight requirement	Must weigh less than 80 kg	1	P	10/20/2014	10/21/2014
5	Slider reliability	Ensure the slider works properly under normal working conditions	Slides freely and does not affect test results	1	B	10/22/2014	10/27/2014
6	Frame Stability	Ensure the frame is sturdy and does not tip during normal use	Does not tip while performing all three functions	1	B	10/25/2014	10/27/2014
7	Tool attachment interchangeability	Verify that tool can be changed/removed easily	1 person can remove/change the tool in one minute	1	B	10/20/2014	10/22/2014
8	Frame Adjustability	Verify that frame can easily be switched between configurations	2 people can reconfigure frame in 5 minutes	1	B	10/20/2014	10/22/2014
9	Jack Recompression	Verify that Jack Recompression Mechanism is capable of compressing jack	Allows one person to recompress 20 ton jack	1	B	10/20/2014	10/27/2014

Appendix K: Calculations

The following pages contain all calculations that were complete during the analysis of the final design.

FRAME ANALYSIS CALCULATIONS:

- I. UPPER C-CHANNELS
- II. LOWER C-CHANNELS
- III. VERTICAL MEMBERS
- IV. SLIDING PRESS PLATE

I. UPPER C-CHANNELS

MODEL AS SIMPLY SUPPORTED BEAM:

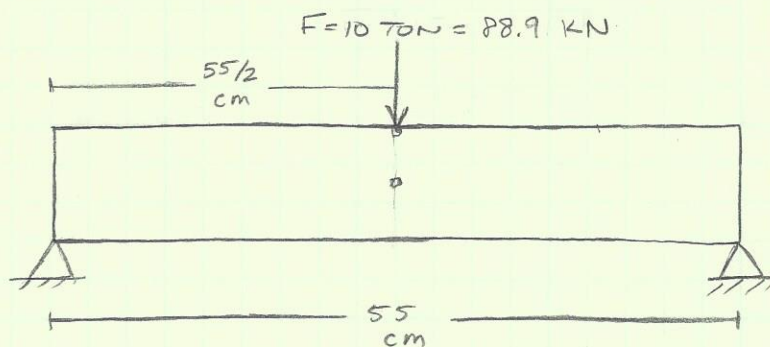

FROM SHIGLEY, APPENDIX A-9:

$$M_{\max} = \frac{FL}{4} = \frac{(88.9 \text{ KN})(0.55 \text{ m})}{4} \rightarrow \underline{M_{\max} = 12233 \text{ N}\cdot\text{m}}$$

$$\sigma_{\max} = \frac{M_{\max} C}{I} \quad \text{EQ. (1)}$$

FOR 125 mm x 65 mm C-CHANNEL,

$$C = 0.125/2 \text{ m}$$

$$I = 424 \text{ cm}^4$$

$$\text{EQ. (1): } \sigma_{\max} = \frac{(12233 \text{ N}\cdot\text{m})(0.125 \text{ m})}{2(424 \times 10^{-8} \text{ m}^4)}$$

$$\underline{\sigma_{\max} = 180.32 \text{ MPa}}$$

I. CONT.

$$\tau = \frac{VQ}{It} \quad \text{EQ. (2)}$$

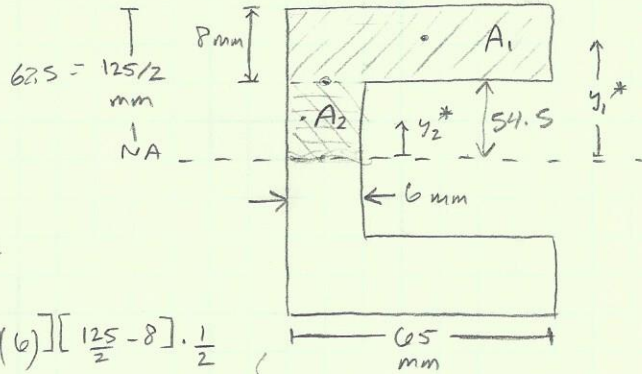

$$\Rightarrow Q = \sum A_i y_i^*$$

$$Q = A_1 y_1^* + A_2 y_2^*$$

$$\Rightarrow \begin{cases} A_1 y_1 = \left[\left(\frac{125}{2} - 8 \right) (6) \right] \left[\frac{125}{2} - 8 \right] \cdot \frac{1}{2} \\ A_2 y_2 = \underline{A_1 y_1} = 8910.75 \text{ mm}^3 \end{cases}$$

$$\Rightarrow \begin{cases} A_2 y_2 = [(8)(65)] \left[\frac{125}{2} - \frac{117}{2} \right] \\ A_1 y_1 = \underline{A_2 y_2} = 30420 \text{ mm}^3 \end{cases}$$

$$A_1 y_1 = (8 \cdot 65 \text{ mm})(58.5 \text{ mm}) = 30420 \text{ mm}^3$$

$$A_2 y_2 = (54.5 \cdot 6 \text{ mm})(27.25 \text{ mm}) = 8910.75$$

$$Q = [8910.75 + 30420] \times 10^{-9} \text{ m}^3$$

$$\underline{Q} = 39330.75 \times 10^{-9} \text{ m}^3$$

$$\text{EQ. (2): } \tau = \frac{(88964.43 \text{ N})(39330.75 \times 10^{-9} \text{ m}^3)}{(424 \times 10^{-8} \text{ m}^4)(6 \times 10^{-3} \text{ m})}$$

$$\underline{\underline{\tau}} = 137.5 \text{ MPa}$$

• Von Mises Equivalent Stresses

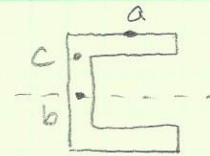

- For plane stress:

$$\sigma' = (\sigma_x^2 - \sigma_x \sigma_y + \sigma_y^2 + 3\tau_{xy}^2)^{1/2} = \frac{S_y}{N}$$

- CASE A:

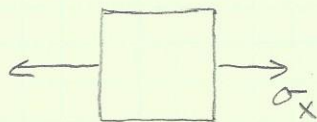
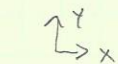

* From Page 1: $\sigma_x = \sigma_{max}$

$$\sigma_x = 180.32 \text{ MPa}$$

$$\tau_{xy} = 0, \sigma_y = 0$$

$$\sigma' = ((180.32 \text{ MPa})^2 - 0 + 0^2 + 3(0)^2)^{1/2} \rightarrow \sigma' = 180.32 \text{ MPa}$$

- CASE B:

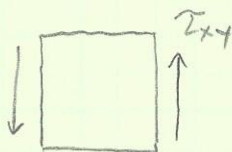

* From Page 2: $\tau_{max} = \tau_{xy}$

$$\tau_{xy} = 137.5 \text{ MPa}$$

$$\sigma_x = 0, \sigma_y = 0$$

$$\sigma' = (3(137.5 \text{ MPa})^2)^{1/2} \rightarrow \sigma' = 238.16 \text{ MPa}$$

- CASE C:

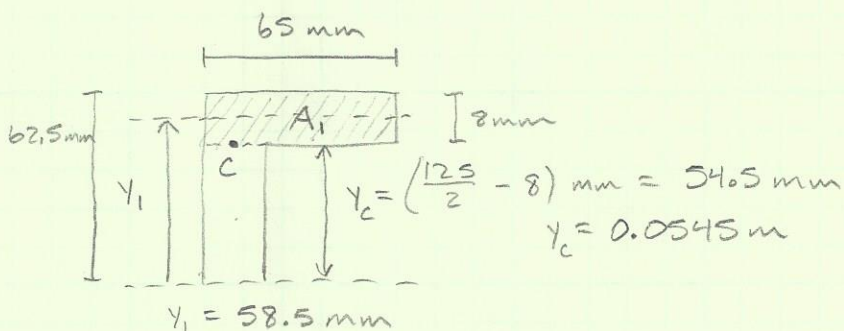
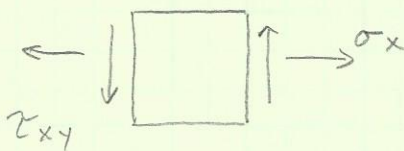
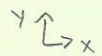

$$\sigma_c = \left(\frac{M y}{I}\right)_c \quad ; \quad M_c = 12233 \text{ N}\cdot\text{m}, y_c = 0.0545 \text{ m}, I = 424 \text{ cm}^4 = 4.24 \times 10^{-6} \text{ m}^4$$

$$\sigma_c = \frac{(12233 \text{ N}\cdot\text{m})(0.0545 \text{ m})}{(4.24 \times 10^6 \text{ m}^4)} \rightarrow \sigma_c = 157240212.3 \frac{\text{N}}{\text{m}^2}$$

$$\underline{\underline{\sigma_c = \sigma_x = 157.24 \text{ MPa}}}$$

$$\tau_c = \left(\frac{VQ}{It} \right)_c, \quad t = \text{thickness at cut}$$

$$Q_c = A_1 y_1 = (8 \text{ mm} \cdot 65 \text{ mm})(58.5 \text{ mm}) = 30420 \text{ mm}^3$$

$$Q_c = 30420 \text{ mm}^3 \rightarrow \underline{\underline{Q_c = 3.042 \times 10^{-5} \text{ m}^3}}$$

$$V = 88964.43 \text{ N}, \quad t = 0.006 \text{ m}, \quad I = 4.24 \times 10^6 \text{ m}^4$$

$$\tau_c = \frac{(88964.43 \text{ N})(3.042 \times 10^{-5} \text{ m}^3)}{(4.24 \times 10^6 \text{ m}^4)(0.006 \text{ m})} = 106379636.8 \frac{\text{N}}{\text{m}^2}$$

$$\underline{\underline{\tau_c = \tau_{xy} = 106.38 \text{ MPa}}}$$

$$\sigma' = \left((157.24 \text{ MPa})^2 + 3(106.38 \text{ MPa})^2 \right)^{1/2}$$

$$\boxed{\sigma' = 242.23 \text{ MPa}}$$

* So CASE C is the highest stress

$$\sigma'_c = \frac{S_y}{N} \rightarrow N = \frac{S_y}{\sigma'_c} = \frac{250 \text{ MPa}}{242.23 \text{ MPa}} = 1.03$$

$$\boxed{N = 1.03}$$

* Will not fail with 20 ton point load

AXIAL LOADING OF UPRIGHT BEAMS

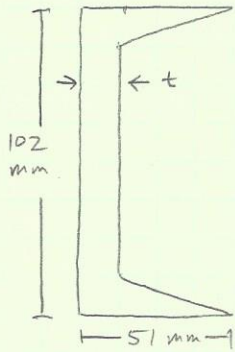

$$I = 207.7 \text{ cm}^4$$

$$t = 5.1 \text{ mm}$$

$$A = 13.28 \text{ cm}^2$$

$$\tau = \frac{VQ}{It}$$

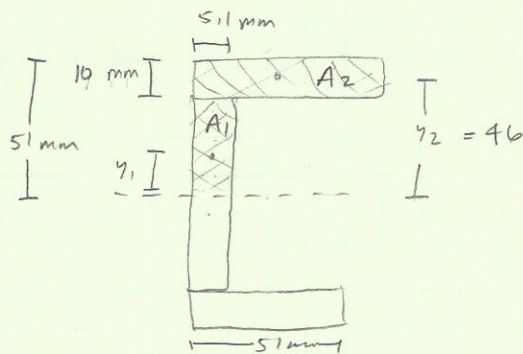

$$y_1 = 20.5 \text{ mm}$$

$$A_1 = (5.1 \times 41) \text{ mm}^2 = 209.1 \text{ mm}^2$$

$$y_2 = 46 \text{ mm}$$

$$A_2 = (10 \times 51) \text{ mm}^2 = 510 \text{ mm}^2$$

$$Q = A_1 y_1 + A_2 y_2$$

$$Q = (20.5 \text{ mm})(209.1 \text{ mm}^2) + (46 \text{ mm})(510 \text{ mm}^2)$$

$$Q = 27746.55 \text{ mm}^3$$

$$\tau = \frac{(90,000 \text{ N})(27746.55 \times 10^{-9}) \text{ m}^3}{(207.7 \times 10^{-8}) \text{ m}^4 (5.1 \times 10^{-3} \text{ m})} \rightarrow \underline{\underline{\tau = 235.7 \text{ MPa}}}$$

$$R = \sqrt{\sigma^2 + \tau^2} \rightarrow R = \sqrt{(235.7 \text{ MPa})^2 + (151.9 \text{ MPa})^2}$$

$$\boxed{R = 280 \text{ MPa}}$$

AXIALLY LOADED BEAMS:

$$\sigma = \frac{P}{A} = \frac{90 \text{ kN}}{13.28 \text{ cm}^2} = \frac{90,000 \text{ N}}{13.28 \times 10^{-4} \text{ m}^2} \rightarrow \boxed{\sigma = 67.8 \text{ MPa}}$$

• Shear Stress of Bolt Group

* Do calc. for one C-channel only

$$r_A = r_B = 2.145 \text{ cm} = 0.02145 \text{ m}$$

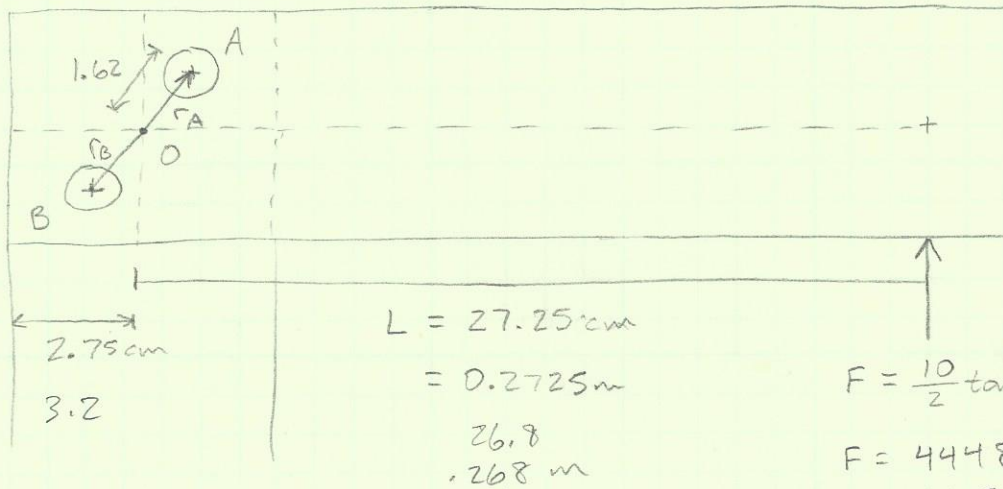

$$F' = \frac{F}{n} = \frac{44.5 \text{ kN}}{2} \rightarrow \underline{\underline{F' = 22.25 \text{ kN}}}$$

$$M = FL = (44.5 \times 10^3 \text{ N})(0.2725 \text{ m}) \rightarrow M = 12126.25 \text{ N}\cdot\text{m}$$

$$\Sigma M_O = M = F_A'' r_A + F_B'' r_B \quad \text{--- (EQ 1)} \quad 11926$$

$$\frac{F_A''}{r_A} = \frac{F_B''}{r_B} \quad \text{--- (EQ 2)}$$

* Solving EQ 1 + 2: $F_j'' = \frac{M r_j}{r_A^2 + r_B^2}$; "j" refers to a specific bolt

$$F_A'' = \frac{M r_A}{r_A^2 + r_B^2} = \frac{(12126.25 \text{ N}\cdot\text{m})(0.02145 \text{ m})}{(0.02145 \text{ m})^2 + (0.02145 \text{ m})^2} \rightarrow F_A'' = 282663.2 \text{ N}$$

241612.6

$$F_A'' = F_B'' = 282.66 \text{ kN}$$

$$F_A = F_B = F_A' + F_A'' = (22.25 + 282.66) \text{ kN} = \underline{\underline{304913.2 \text{ N} = F_A}}$$

263862

* Direct Shear Stress

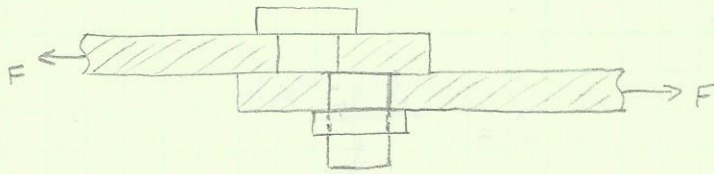

$$\tau = \frac{F}{A} \leq \frac{S_y}{2N} \quad ; \quad \text{where } A = \frac{\pi d^2}{4}$$

* For Grade 8 Bolt: $S_y = 130 \times 10^3 \text{ psi} \left(\frac{6.895 \text{ KPa}}{1 \text{ psi}} \right)$

$$S_y = 896350 \text{ KPa} \rightarrow S_y = 896.35 \text{ MPa}$$

* Assuming $N=1$ + $F = \frac{F}{2}$ for 2 bolts

$$\frac{F}{A} \leq \frac{S_y}{2N} \rightarrow \frac{F(0.5)}{\frac{\pi d^2}{4}} \leq \frac{S_y}{2} \rightarrow \frac{F(0.5)4}{\pi} \leq \frac{S_y}{2} d^2$$

$$\frac{(4)(304.9 \text{ kN})(0.5)}{\pi} \leq \frac{(896.35 \times 10^6 \frac{\text{N}}{\text{m}^2})}{2} d^2$$

$$194113.75 \text{ N} \leq 448175000 \frac{\text{N}}{\text{m}^2} (d^2)$$

$$d = 27.4 \text{ mm}$$

$$d^2 \geq 4.331 \times 10^{-4} \text{ m}^2 \rightarrow d = 0.0208 \text{ m} \left(\frac{1000 \text{ mm}}{1 \text{ m}} \right)$$

$$d = 20.8 \text{ mm}$$

$$\frac{2.54 \text{ cm}}{1 \text{ in}}$$

$$\frac{44500 \text{ N}}{\pi d^2} \leq 896.35 \times 10^6 \frac{\text{N}}{\text{m}^2}$$

$$d^2 \geq \frac{44500 \text{ N}}{\pi (896.35 \times 10^6 \frac{\text{N}}{\text{m}^2})} = 1.768 \times 10^{-5} \text{ m}^2 \left(\frac{1000 \text{ mm}}{1 \text{ m}} \right)^2$$

$$d = 15.8 \text{ mm}$$

• Minimum Bolt Size Calculation

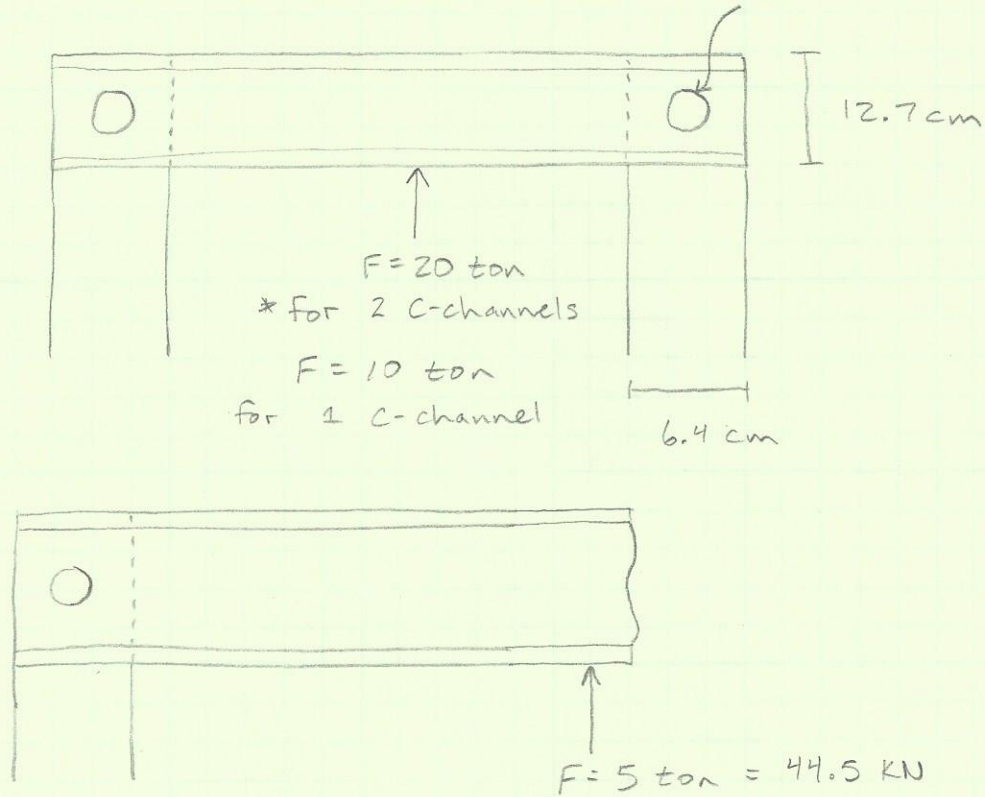

- Need to find shear stress on single bolt

$$\tau = \frac{V}{A} \leq \frac{S_y}{2N}$$

* For Grade 8 bolt: $S_y = 130 \text{ Kpsi}$

$$S_y = 896.35 \text{ MPa}$$

* Assume factor of safety is 1.5 $\rightarrow N = 1.5$

$$\frac{V}{A} \leq \frac{S_y}{2(1.5)} \rightarrow A \geq \frac{3V}{S_y}$$

$$A \geq \frac{3(44500 \text{ N})}{(896.35 \times 10^6 \text{ N/m}^2)} \rightarrow A \geq 1.489 \times 10^{-4} \text{ m}^2$$

$$A = \frac{\pi d^2}{4} \rightarrow \frac{\pi d^2}{4} \geq 1.489 \times 10^{-4} \text{ m}^2 \rightarrow d^2 \geq 1.896 \times 10^{-4} \text{ m}^2$$

$$d \geq 0.0138 \text{ m} \rightarrow \boxed{d \geq 13.77 \text{ mm} \approx 0.54 \text{ in}}$$

* Choose M14 x 200 mm Class 10.9

• Bearing Failure of Bolt on Member

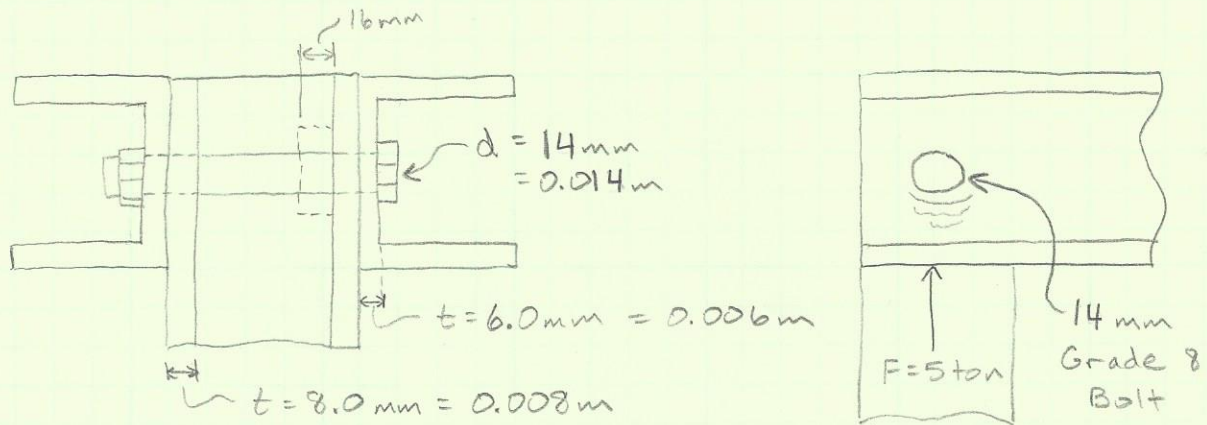

$$\sigma = \frac{F}{A} \leq \frac{S_y}{N}$$

* For A-36 Structural Steel:

$$S_y = 250 \text{ MPa}$$

$$F = 5 \text{ ton} = 10,000 \text{ lbf} \rightarrow \underline{F = 44.5 \text{ kN}}$$

$A = td$, where t = minimum plate thickness
 d = bolt diameter

$$A = (0.006 \text{ m})(0.014 \text{ m}) \rightarrow \underline{A = 8.4 \times 10^{-5} \text{ m}^2}$$

* Assume factor of safety of 2 $\rightarrow \underline{N = 2}$

$$\frac{F}{A} \leq \frac{S_y}{N} \rightarrow \frac{NF}{A} \leq S_y \rightarrow \frac{(2)(44500 \text{ N})}{(8.4 \times 10^{-5} \text{ m}^2)} \stackrel{?}{\leq} S_y$$

$$927.1 \text{ MPa} \not\leq S_y = 250 \text{ MPa}$$

* Set up calc. to find "t" needed:

$$\frac{F}{A} \leq \frac{S_y}{N} \rightarrow \frac{F}{td} \leq \frac{S_y}{N} \rightarrow \frac{FN}{dS_y} \leq t$$

$$t \geq \frac{FN}{d S_y} = \frac{(44500 \text{ N})(2)}{(0.014 \text{ m})(250 \times 10^6 \frac{\text{N}}{\text{m}^2})} = 0.0257 \text{ m}$$

$$t \geq 0.0257 \text{ m} \rightarrow \boxed{t \geq 25.7 \text{ mm}}$$

* This is the minimum thickness that a plate needs to be in order to not deform with our given criteria

- we need to add-on to our existing C-channel thickness to achieve the necessary "t"

$$t_{\text{add}} = t_{\text{min}} - 6.0 \text{ mm} = (25.7 - 6) \text{ mm}$$

$$\boxed{t_{\text{add}} = 19.7 \text{ mm} \approx 0.776 \text{ in}}$$

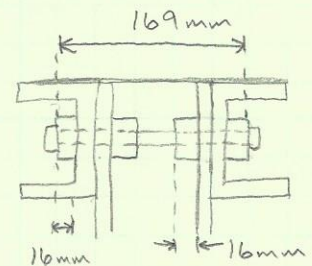

* Choose to use $t = 16 \text{ mm}$ flat steel plate

- Will decrease "N" slightly, but that is okay

* Would have to order (3x6)ft by 16mm thick

* Need 8 pieces of steel plate this size

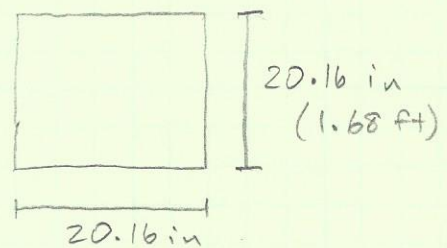
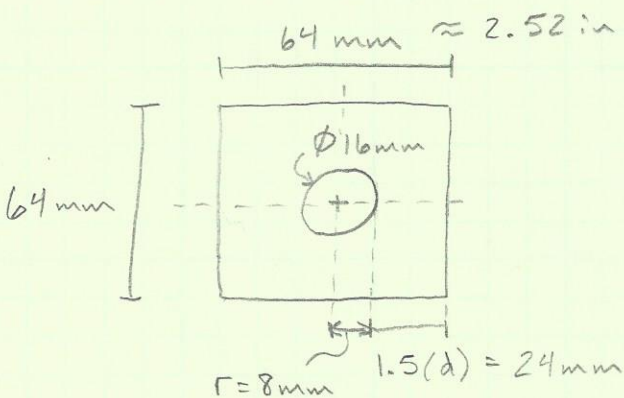

WELD SIZING OF LOWER C-CHANNEL

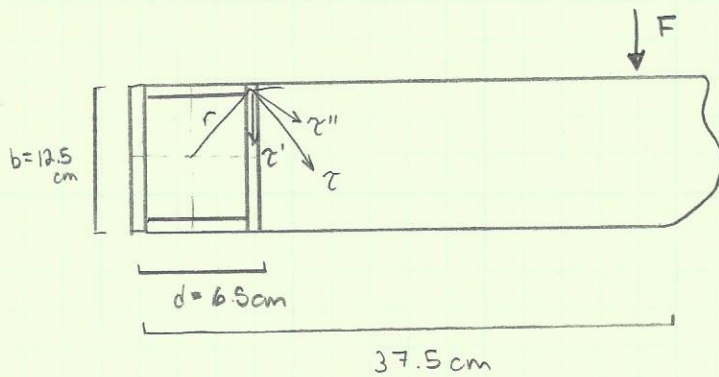

$$F = 5 \text{ ton}$$

$$r = \sqrt{\left(\frac{6.5}{2}\right)^2 + \left(\frac{12.5}{2}\right)^2}$$

$$r = 7.04 \text{ cm} \\ = .07 \text{ m}$$

$$A = 1.414 h (b + d)$$

$$= 1.414 h (.125 + .065) = .26866 h \text{ m}^2$$

$$J_u = \frac{(b+d)^3}{6}$$

$$= \frac{(.125 + .065)^3}{6} = .001143 \text{ m}^2$$

$$\therefore J = .707 h \cdot J_u$$

$$= (.707)(.001143 \text{ m}^2) h = 8.082 \times 10^{-4} \cdot h \text{ m}^4$$

PRIMARY SHEAR, $\tau' = \frac{F}{A} = \frac{F}{.26866 h}$

$$\tau' = \frac{48 \text{ kN}}{.26866 h} = \frac{178.66}{h} \text{ kPa}$$

SECONDARY SHEAR, $\tau'' = \frac{Mx}{J}$

$$\tau''_x = \frac{(48000 \text{ N})(.3425 \text{ m})(.0625 \text{ m})}{8.082 \times 10^{-4} h \text{ m}^4}$$

$$\tau''_x = \frac{1271.3}{h} \text{ kPa}$$

$$\tau''_y = \frac{(48000 \text{ N})(.3425 \text{ m})(.0325 \text{ m})}{8.082 \times 10^{-4} h \text{ m}^4}$$

$$\tau''_y = \frac{661.1}{h} \text{ kPa}$$

$$\tau_{\max} = \sqrt{(\tau' + \tau_y'')^2 + (\tau_x'')^2}$$

$$\tau_{\max} = \sqrt{\left(\frac{178.66}{h} + \frac{661.1}{h}\right)^2 + \left(\frac{1271.3}{h}\right)^2}$$

$$\tau_{\max} = \frac{1523.6}{h} \text{ kPa}$$

$$\tau_{\text{allow}} = 0.4 S_y = 0.4 (500 \text{ MPa})$$

$$\tau_{\text{allow}} = 200 \text{ MPa}$$

$$\tau_{\max} \leq \tau_{\text{allow}}$$

$$\frac{1.5236}{h} \text{ MPa} \leq 200 \text{ MPa}$$

$$h \geq \frac{1.5236}{200} \text{ m}$$

$$h \geq .0076 \text{ m} = 7.6 \text{ mm}$$

use 1.27 cm ($\frac{1}{2}$ ") fillet welds for a
f.s. of 1.7.

WELD SIZING FOR FRAME WALL DOUBLING PLATES:

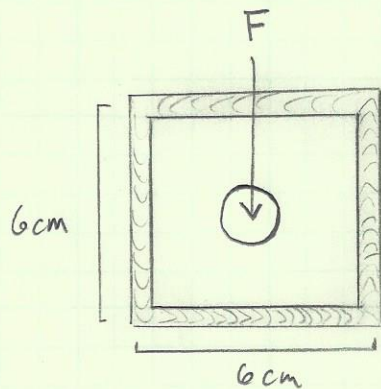

$$A = 1.414 h (b + d)$$

$$A = 1.414 h (.06 + .06)$$

$$A = .16968 h \text{ m}^2$$

$$\tau = \frac{F}{A} = \frac{48 \text{ kN}}{.16968 h \text{ m}^2}$$

$$\tau = \frac{.283 \text{ MPa}}{h}$$

$$\tau \leq \tau_{\text{allow}}$$

$$\tau_{\text{allow}} = 0.4 S_y = 0.4 (500 \text{ MPa})$$

$$\tau_{\text{allow}} = 200 \text{ MPa}$$

$$\frac{.283 \text{ MPa}}{h} \leq 200 \text{ MPa}$$

$$h > .0014 \text{ m} \approx 2 \text{ mm}$$

Use 8 mm fillet weld for a F.O.S. of 4.

• Sizing of Flat Plate on Bottom of Slider

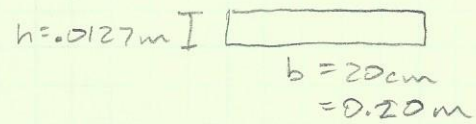
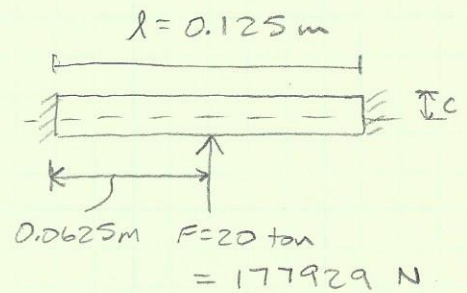
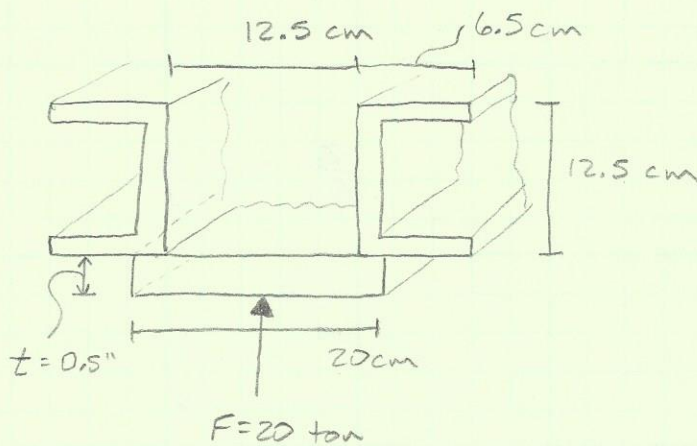

* Plate is 20 x 20 cm

$$\sigma = \frac{My}{I} \rightarrow \sigma_{max} = \frac{M_{max}c}{I}$$

$$M_{max} = \frac{Fl}{8} = \frac{(177929 \text{ N})(0.125 \text{ m})}{8} \rightarrow \underline{M_{max} = 2780.1 \text{ N}\cdot\text{m}}$$

* Assume using 0.5 in plate (12.7 mm): $c = 0.00635 \text{ m}$

$$I = \frac{bh^3}{12} = \frac{(0.2 \text{ m})(0.0127 \text{ m})^3}{12} \rightarrow I = 3.414 \times 10^{-8} \text{ m}^4$$

$$\sigma_{max} = \frac{Mc}{I} = \frac{(2780.1 \text{ N}\cdot\text{m})(0.00635 \text{ m})}{(3.414 \times 10^{-8} \text{ m}^4)} \rightarrow \sigma_{max} = 517 \text{ MPa}$$

$$\sigma_{max} \neq S_y = 250 \text{ MPa} \rightarrow 517 \text{ MPa} \neq 250 \text{ MPa}$$

* 12.7 mm flat plate is too small and will yield
 - can either increase thickness or add gussets between the C-channels on top of plate

$$\tau = \frac{VQ}{It}$$

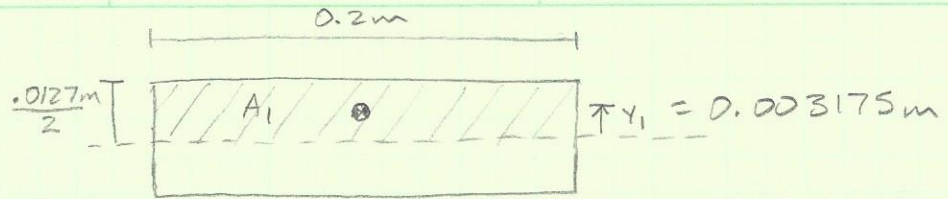

$$Q = A_1 y_1 = \left(\frac{0.0127\text{m}}{2} \right) (0.2\text{m}) (0.003175\text{m})$$

$$Q = 4.032 \times 10^{-6} \text{ m}^3$$

$$I = 3.414 \times 10^{-8} \text{ m}^4, \quad t = 0.2\text{m}, \quad V = 177929 \text{ N}$$

$$\tau = \frac{(177929 \text{ N})(4.032 \times 10^{-6} \text{ m}^3)}{(3.414 \times 10^{-8} \text{ m}^4)(0.2\text{m})} = 105068794 \frac{\text{N}}{\text{m}^2}$$

$$\tau = 105.1 \text{ MPa}$$

$$\tau \leq S_y$$

* So we only have to worry about σ_{\max}

- Instead of increasing the thickness, we will add gussets to the top for support

SIZING OF PRESS TOOL PLATE:

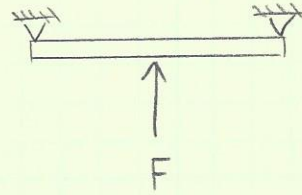
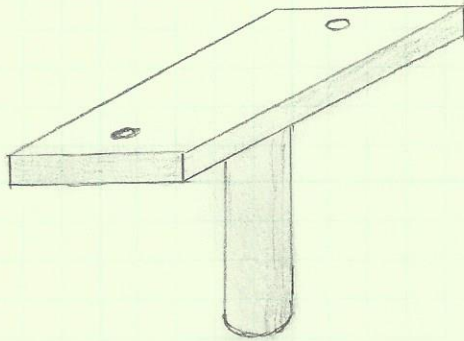

ASSUME 5 TON FORCE USED FOR PRESSING:

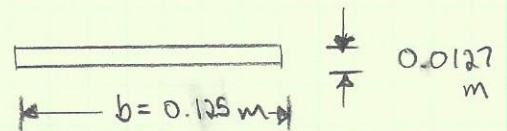

$$\sigma = \frac{Mc}{I}$$

$$M_{\max} = \frac{Fl}{8} = \frac{(44.5 \text{ kN})(0.125 \text{ m})}{8} \rightarrow M_{\max} = 695 \text{ N}\cdot\text{m}$$

$$c = \frac{.0127 \text{ mm}}{2} = .00635 \text{ m}$$

$$I = \frac{bh^3}{12} = \frac{(0.125)(0.0127)^3}{12} = 2.13 \times 10^{-8} \text{ m}^4$$

$$\sigma_{\max} = \frac{(695 \text{ N}\cdot\text{m})(.00635 \text{ m})}{2.13 \times 10^{-8} \text{ m}^4}$$

$$\sigma_{\max} = 205 \text{ MPa} < 250 \text{ MPa}$$

FOR A 5 TON LOAD, A $\frac{1}{2}$ " (.0127m) THICK PLATE IS SUFFICIENT.

IF A LARGER F.O.S. IS REQUIRED, OR A LARGER PRESSING FORCE IS NEEDED, THE PLATE CAN BE DOUBLED TO OBTAIN A GREATER THICKNESS.

Appendix L: Engineering Drawings

The following pages contain all of the engineering drawings for the press.

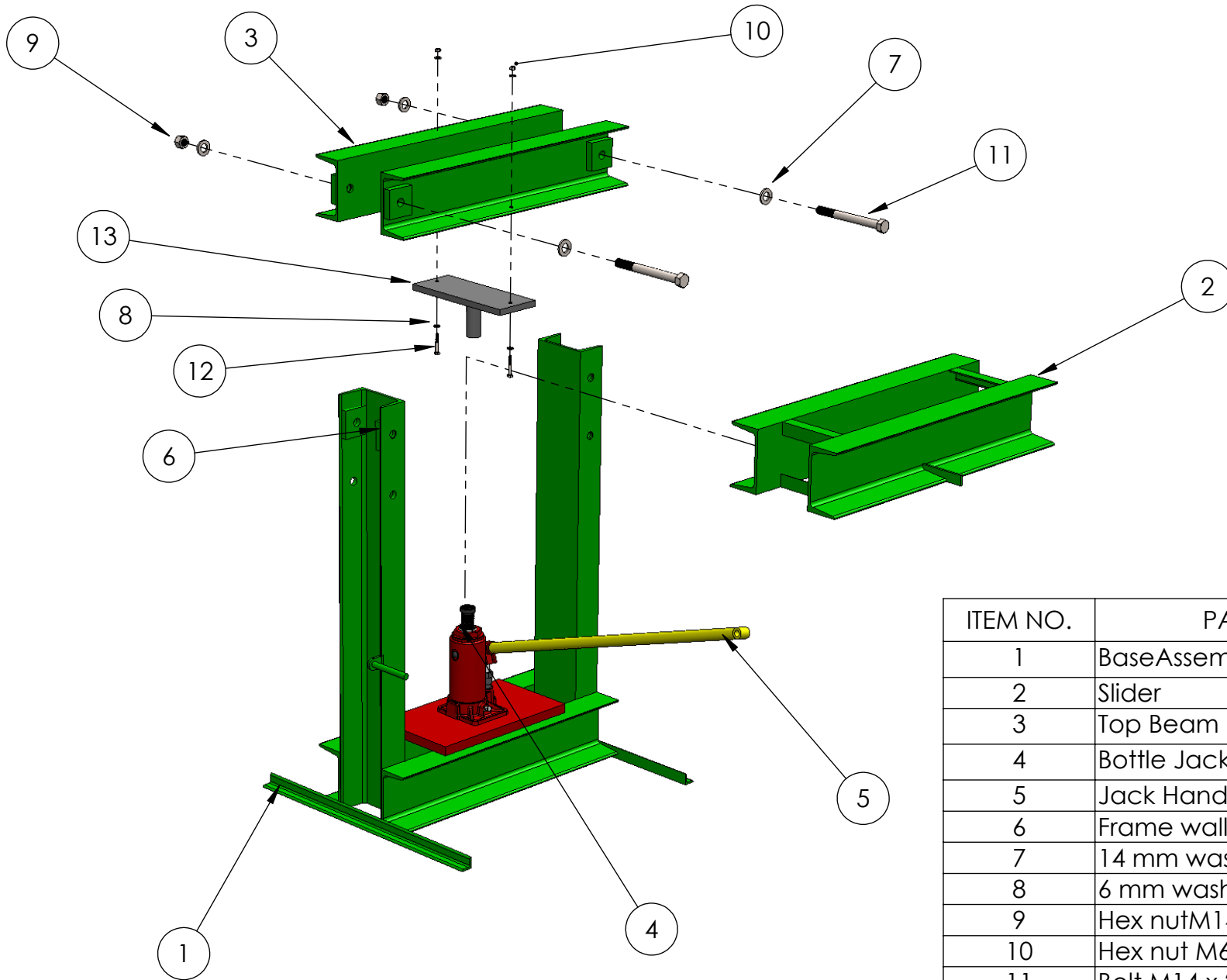

ITEM NO.	PART	QTY.
1	BaseAssembly	1
2	Slider	1
3	Top Beam	2
4	Bottle Jack Assembly	1
5	Jack Handle	1
6	Frame wall doubler	12
7	14 mm washer	4
8	6 mm washer	4
9	Hex nutM14 x 2	2
10	Hex nut M6 x 1	2
11	Bolt M14 x 2.0 x 200	2
12	Bolt M6 x 1.0 x 40	2
13	Tool Attachment	1

Cal Poly Mechanical Engineering
CT5

CVBT THAILAND
Dwg. #:CT5-990

Rev: A
Nxt DRW: CT5-991

Title: CT5 Assembly
Date:4-24-14

Scale: 1:10

Drwn. By: Taylor Vandenhoeck
Chkd. By: Colby Johnson

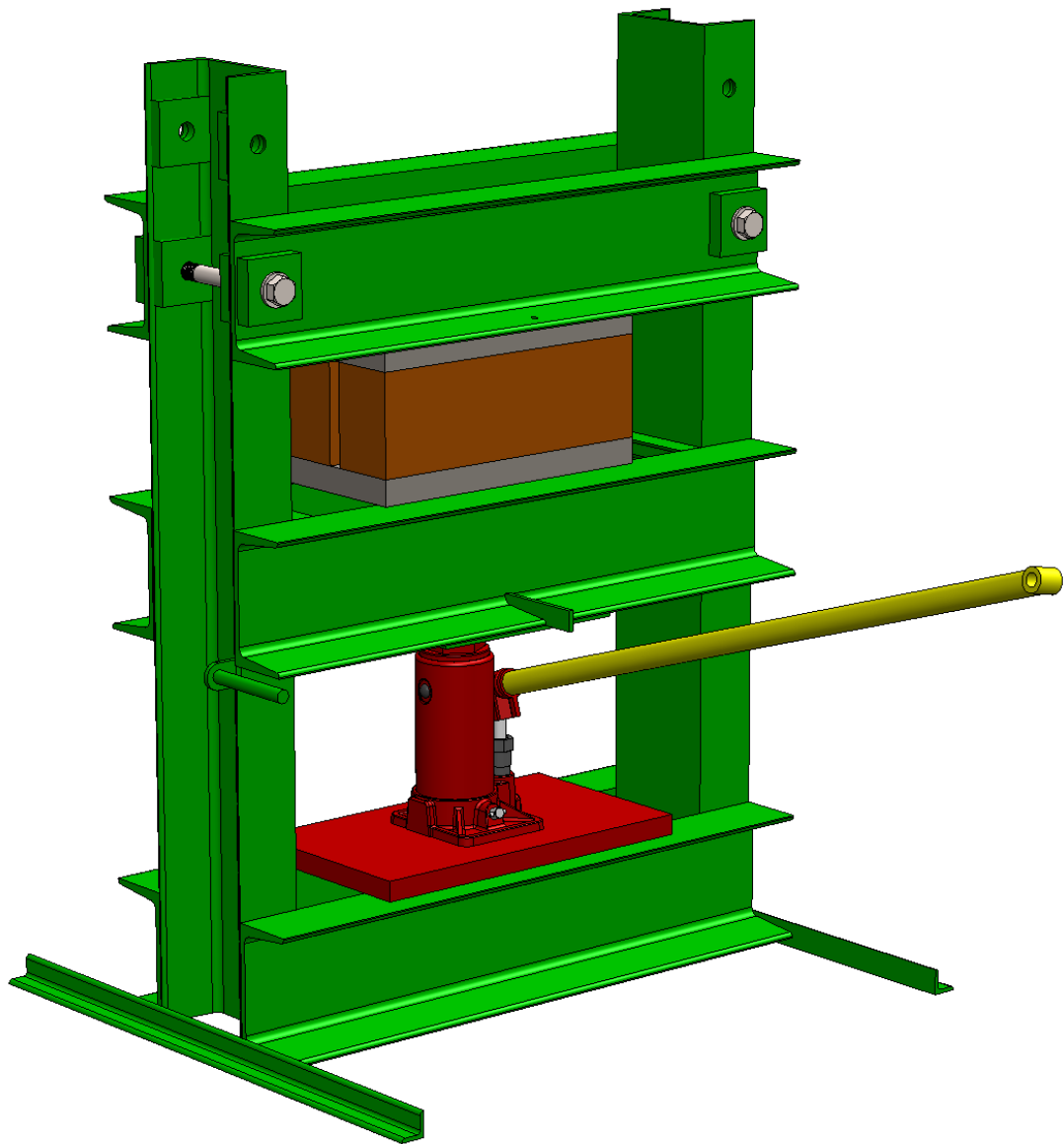

Cal Poly Mechanical Engineering CT5	CVBT THAILAND	Rev: A	Title: Compression Test Layout		Drwn. By: Taylor Vandenhoeck
	Dwg. #:CT5-991	Nxt DRW: CT5-992	Date:4-24-14	Scale: 1:6	Chkd. By: Colby Johnson

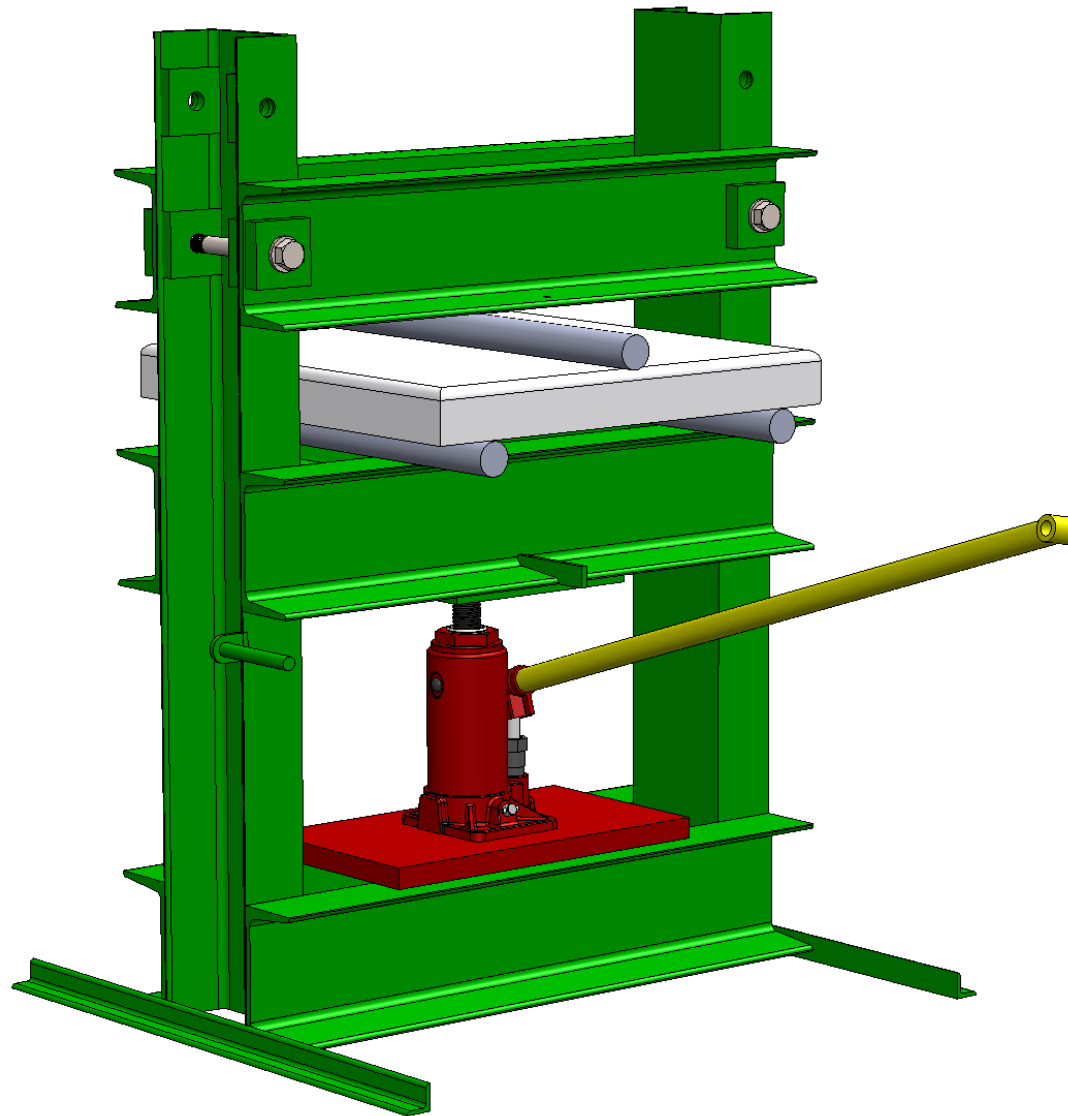

Cal Poly Mechanical Engineering
CT5

CVBT THAILAND
Dwg. #:CT5-992

Rev: A
Nxt DRW: CT5-993

Title: Beding Test Layout
Date:4-24-14

Scale: 1:6

Drwn. By: Taylor Vandenhoeck
Chkd. By: Colby Johnson

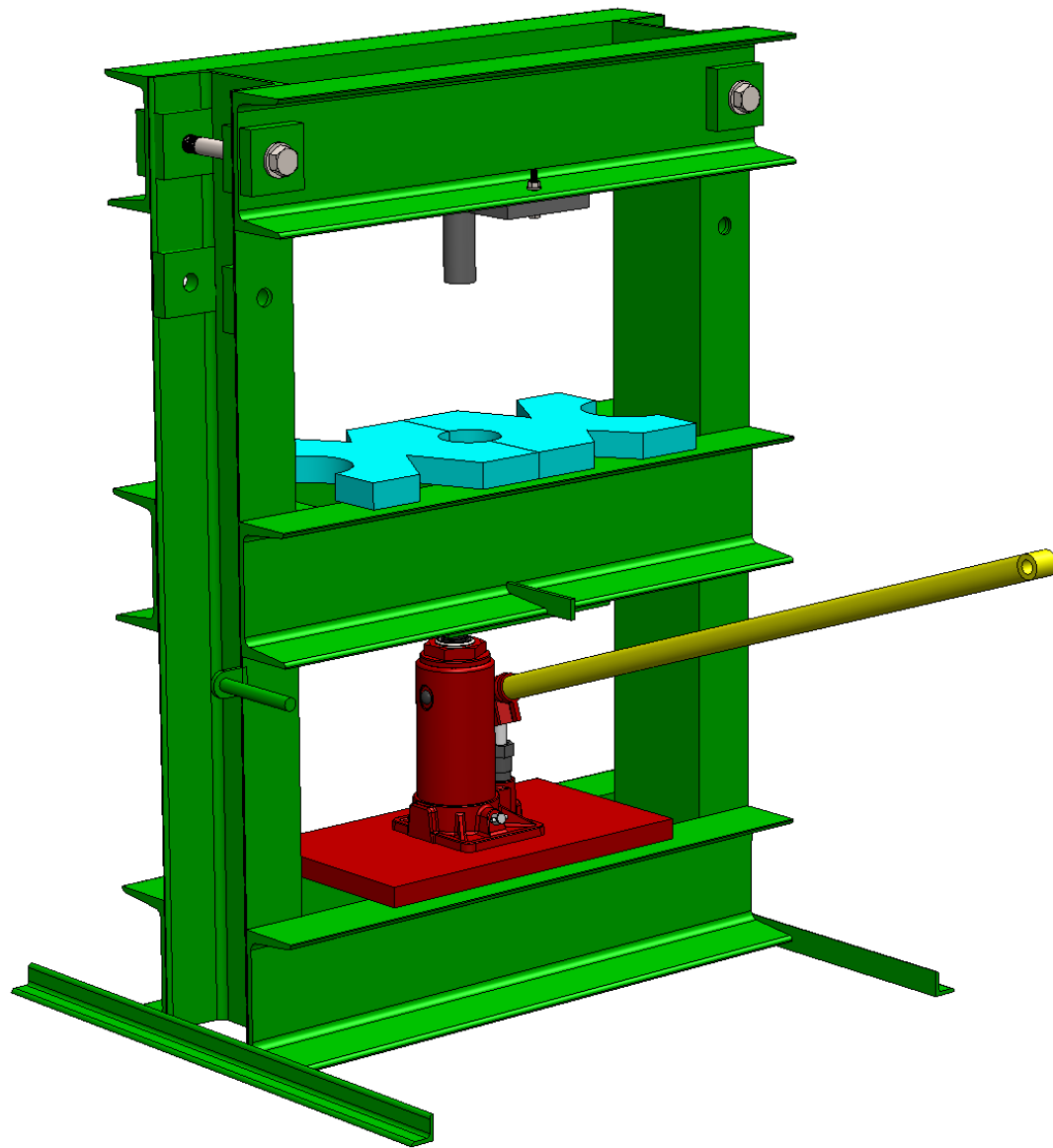

Cal Poly Mechanical Engineering
CT5

CVBT THAILAND
Dwg. #:CT5-993

Rev: A
Nxt DRW: CT5-994

Title: Shop Press Layout
Date:4-24-14

Scale: 1:6

Drwn. By: Taylor Vandenhoeck
Chkd. By: Colby Johnson

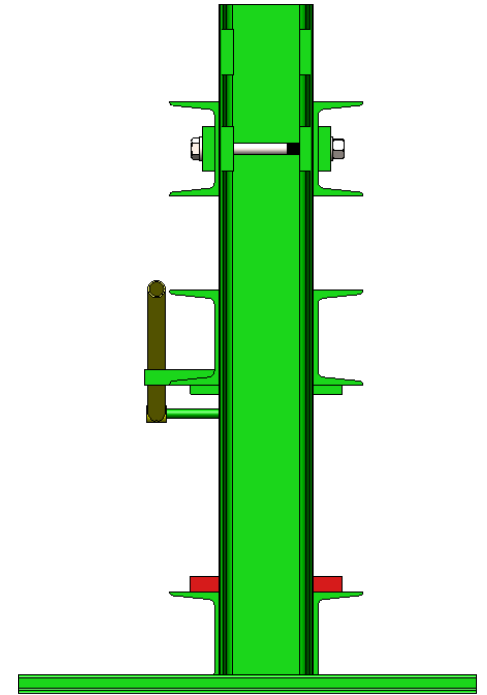
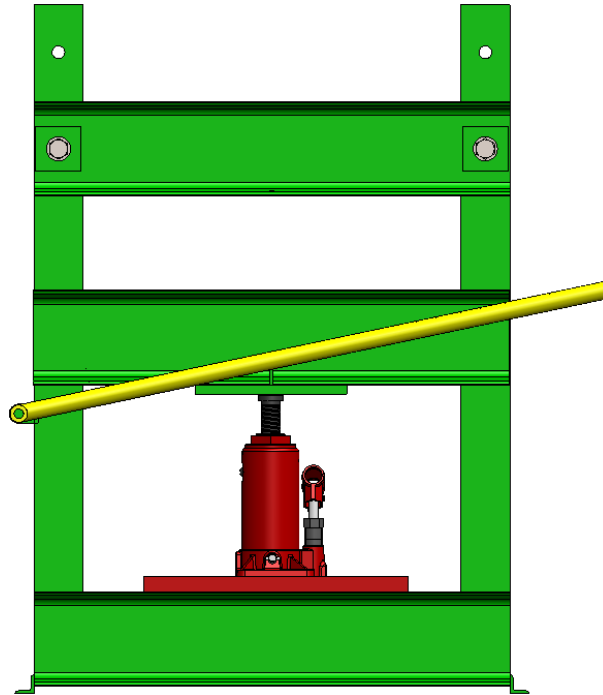
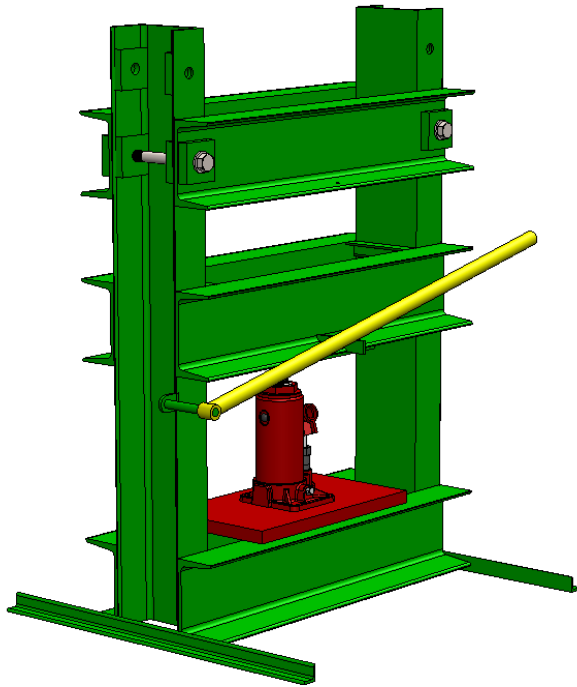

Cal Poly Mechanical Engineering CT5	CVBT THAILAND	Rev: A	Title: Recompression Layout		Drwn. By: Taylor Vandenhoeck
	Dwg. #:CT5-994	Nxt DRW: CT5-995	Date:4-24-14	Scale: 1:10	Chkd. By: Colby Johnson

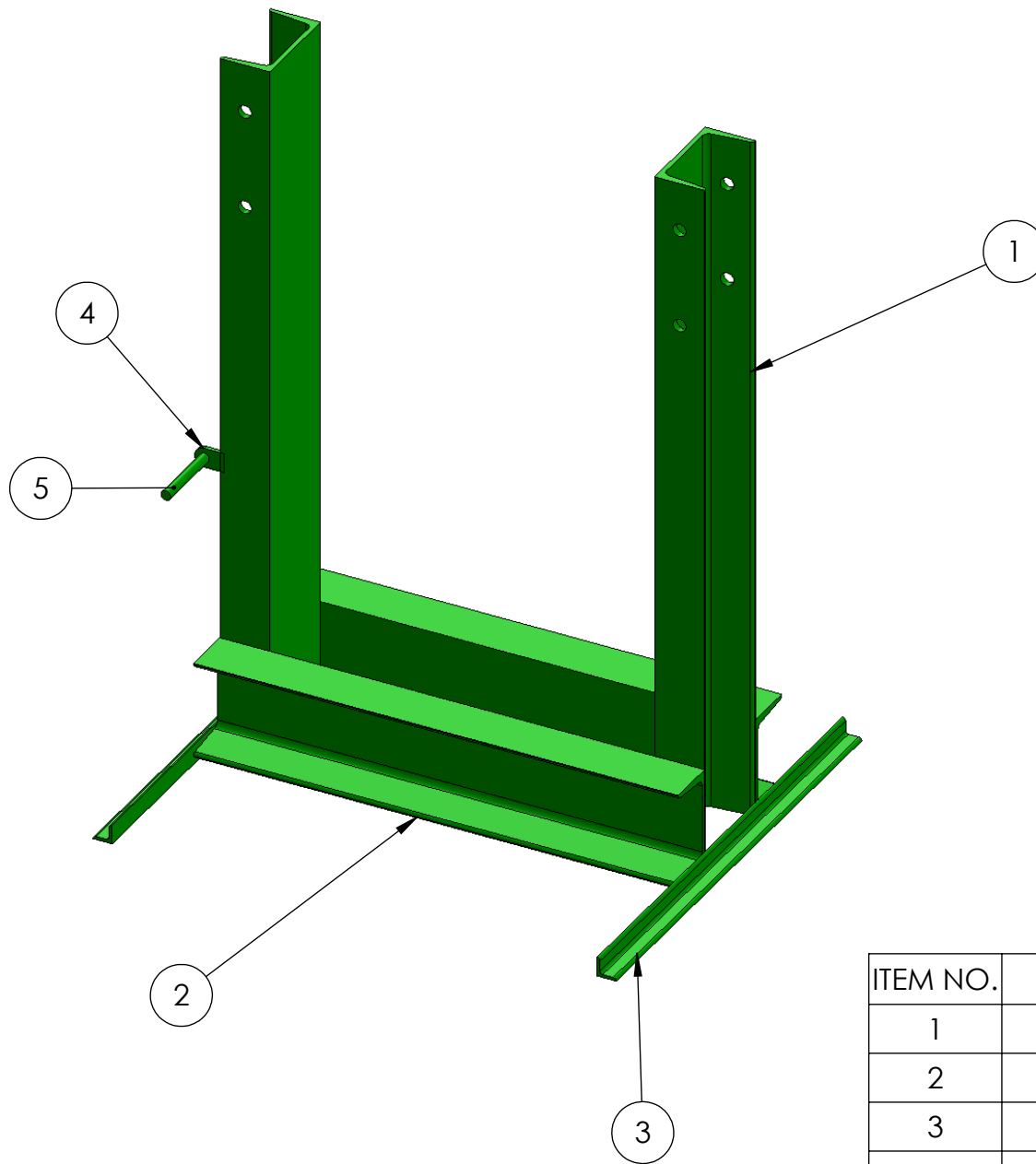

ITEM NO.	DESCRIPTION	QTY.
1	C CHANNEL 12.500 X 12	2
2	C CHANNEL 12.500 X 12	2
3	L 2.500 X 2.500 X 0.400	2
4	PIVOT TAB	1
5	PIVOT ROD	1

Cal Poly Mechanical Engineering
CT5

CVBT THAILAND
Dwg. #:CT5-010

Rev: A
Nxt DRW: CT5-011

Title: Base Assembly
Date:4-24-14

Scale: 1:8

Drwn. By: Taylor Vandenhoeck
Chkd. By: Colby Johnson

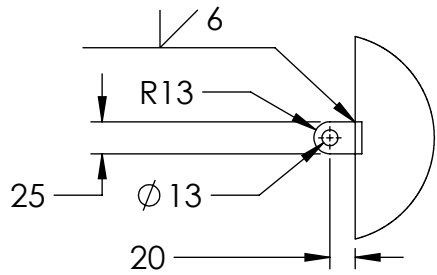

DETAIL A
SCALE 1 : 6

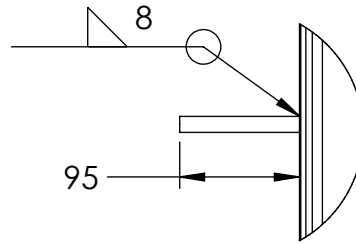

DETAIL B
SCALE 1 : 6

NOTES:

- 1) ALL DIMENSIONS IN MM.
- 2) X = +/-0.5
X.X = +/-0.2
X.XX = +/-0.1
- 3) PLATE IN DETAIL A 12 MM THICK.

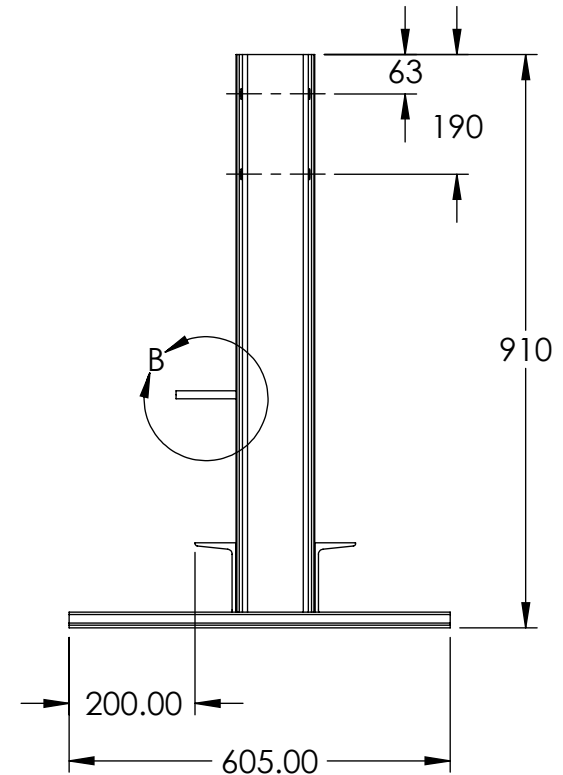
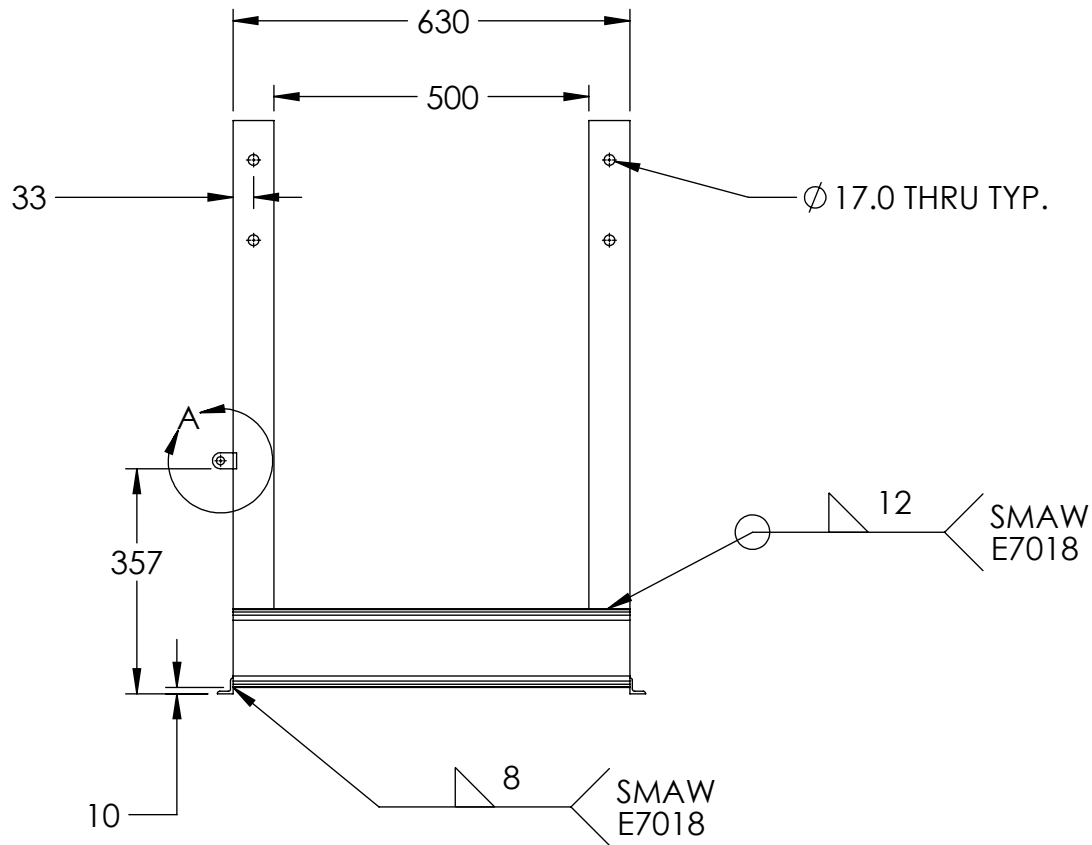

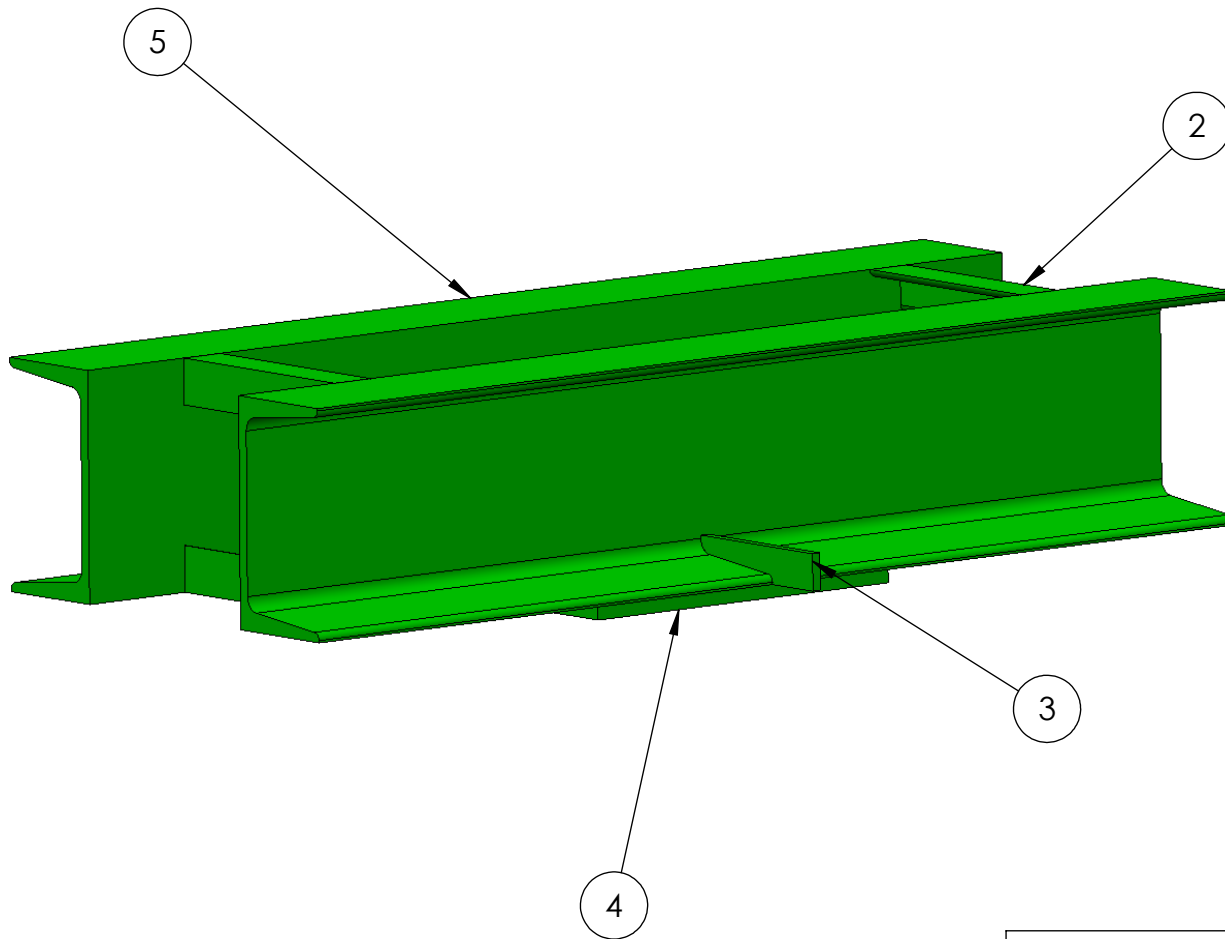

ITEM NO.	DESCRIPTION	QTY.
1	C CHANNEL 12.500 X 12	1
2	L 2.500 X 2.500 X 0.400	4
3	COMPRESSION TAB	1
4	JACK PLATE	1
5	C CHANNEL 12.500 X 12	1

Cal Poly Mechanical Engineering CT5	CVBT THAILAND	Rev: A	Title: SLIDER ASSEMBLY	5	Drawn By: ANNE L V 215001042
	Dwg. #:CT5-020	Nxt DRW: CT5-021	Date:4-24-14		Scale: 1:4

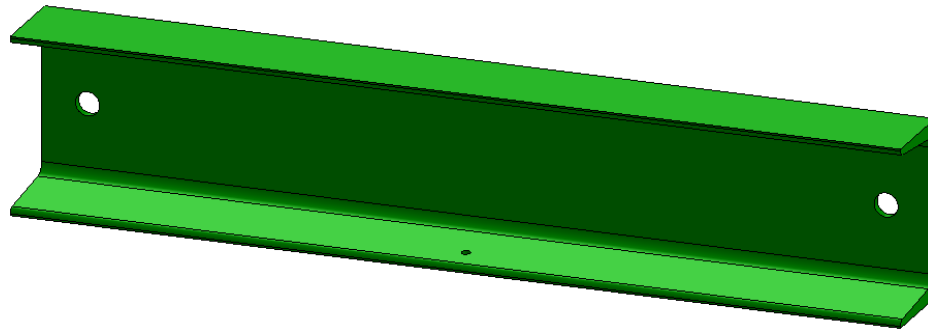

Cal Poly Mechanical Engineering CT5	CVBT THAILAND	Rev: A	Title: TOP BEAM		Drwn. By: Taylor Vandenhoeck
	Dwg. #:CT5-030	Nxt DRW: CT5-031	Date:4-24-14	Scale: 1:8	Chkd. By: Colby Johnson

NOTES:

- 1) ALL DIMENSIONS IN MM.
- 2) X = +/-0.5
X.X = +/-0.2
X.XX = +/-0.1

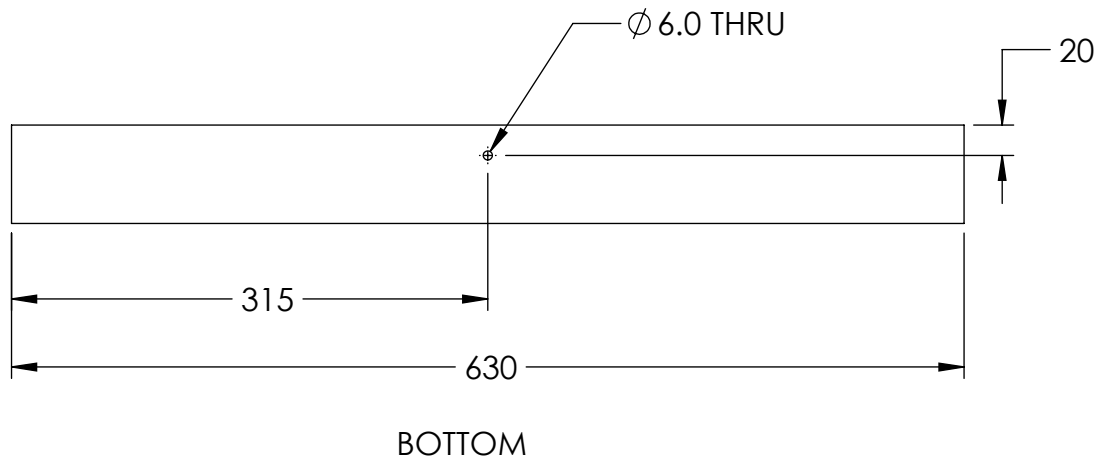
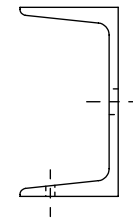
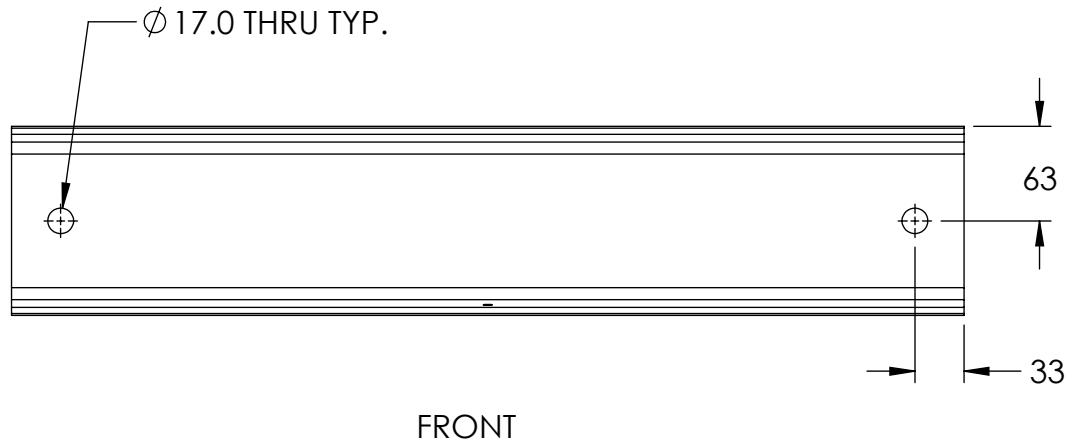

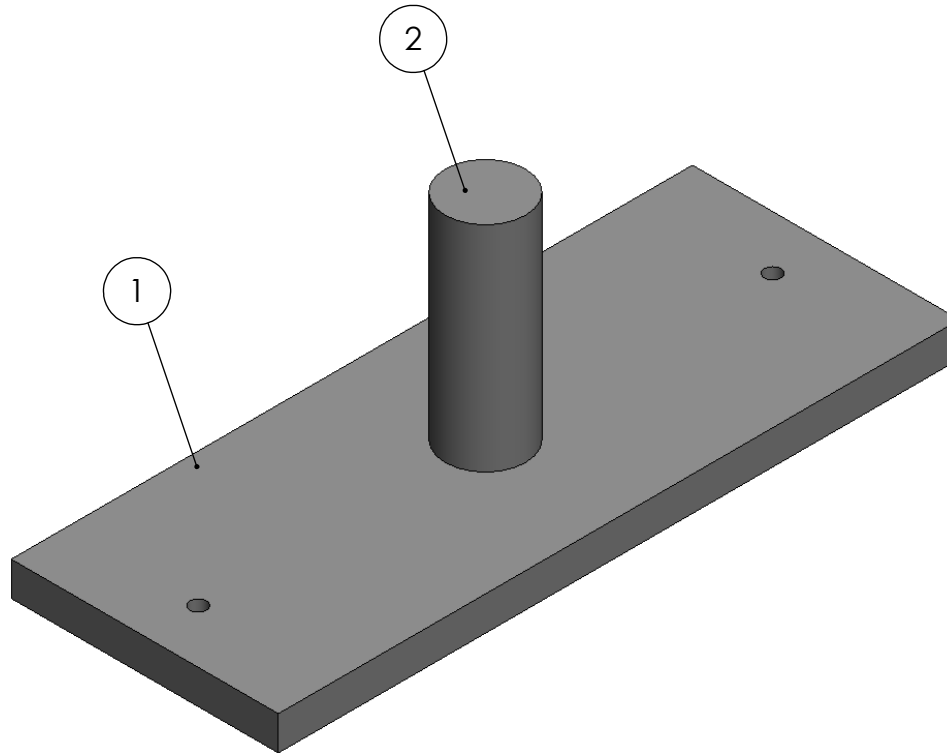

ITEM NO.	DESCRIPTION	QTY.
1	15 MM PLATE	1
2	25.4 MM ROD	1

Cal Poly Mechanical Engineering CT5	CVBT THAILAND	Rev: A	Title: TOOL ATTACHMENT		Drwn. By: Taylor Vandenhoeck
	Dwg. #:CT5-040	Nxt DRW: CT5-041	Date:4-24-14	Scale: 1:2	Chkd. By: Colby Johnson

NOTES:

- 1) ALL DIMENSIONS IN MM.
- 2) X = +/-0.5
X.X = +/-0.2
X.XX = +/-0.1

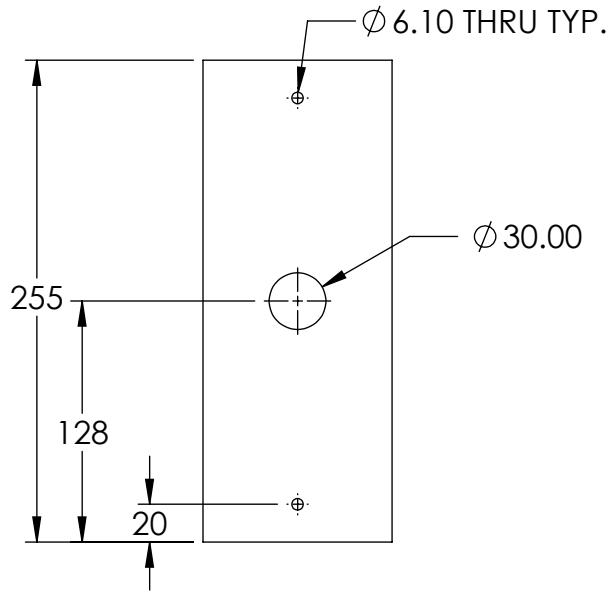

BOTTOM

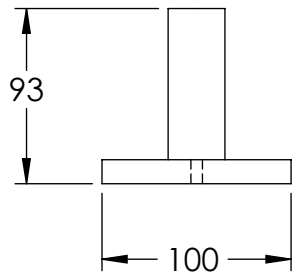
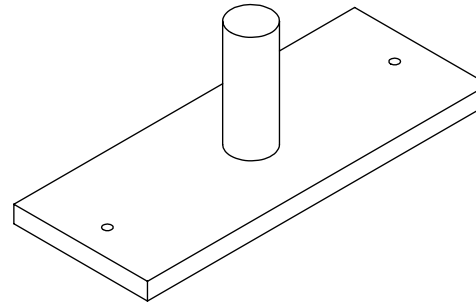

FRONT

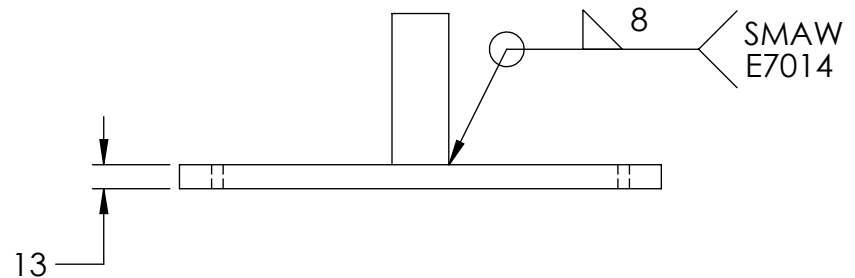

SIDE

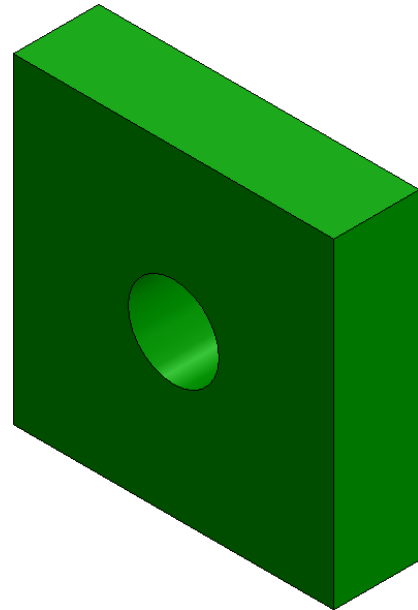

Cal Poly Mechanical Engineering CT5	CVBT THAILAND	Rev: A	Title: Frame Wall Doubling Plate		Drwn. By: Taylor Vandenhoeck
	Dwg. #:CT5-050	Nxt DRW: CT5-051	Date:4-24-14	Scale: 1:1	Chkd. By: Colby Johnson

NOTES:

- 1) ALL DIMENSIONS IN MM.
- 2) X = +/-0.5
X.X = +/-0.2
X.XX = +/-0.1

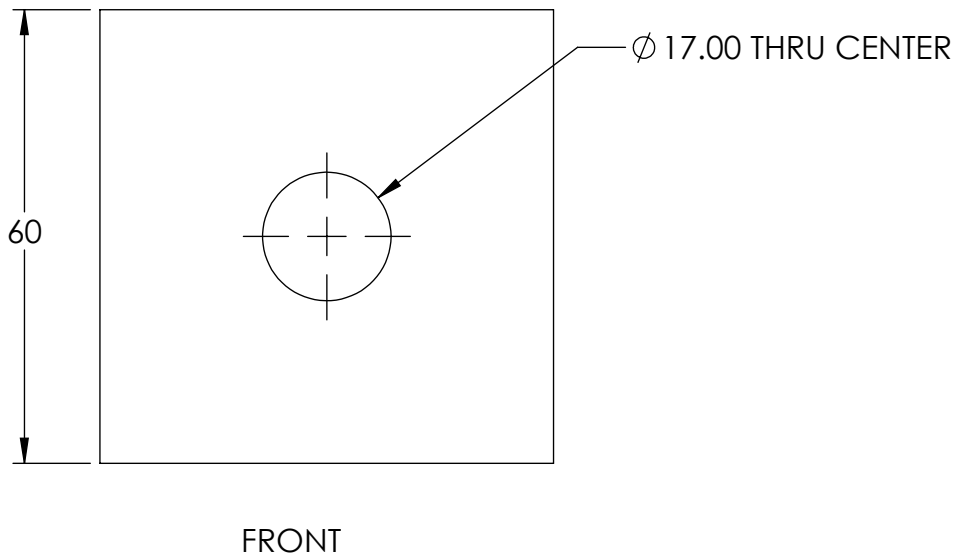
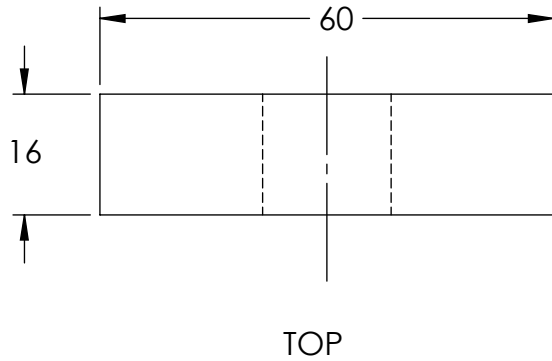

NOTES:

- 1) ALL DIMENSIONS IN MM.
- 2) X = +/-0.5
X.X = +/-0.2
X.XX = +/-0.1

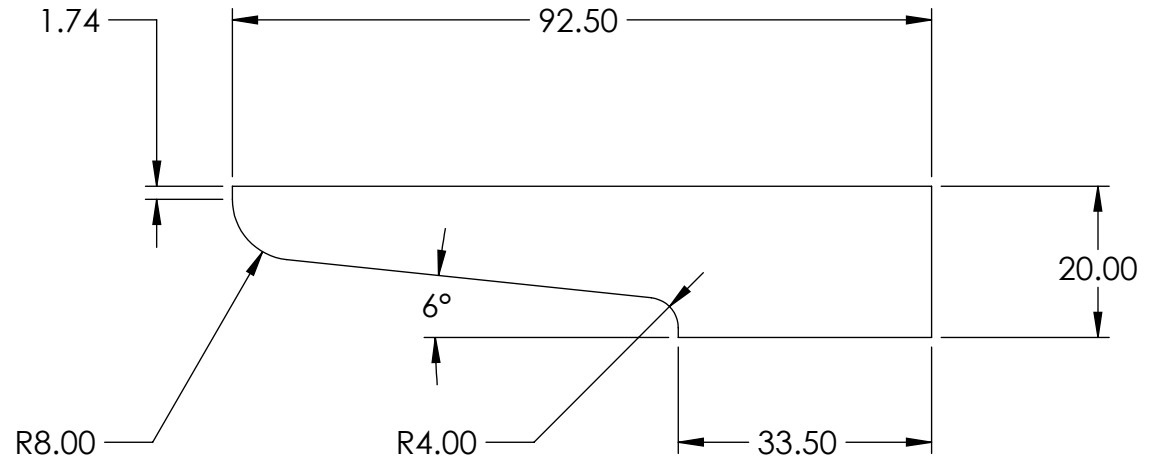
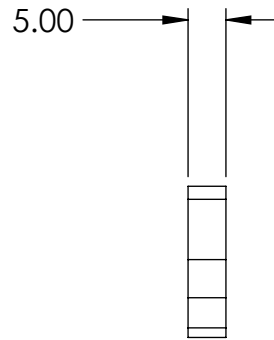

Appendix M: Safety and Operation Manual

The Compression Tester Shop Press was designed to be as simple and safe to use as possible while still meeting the design requirements. Before using the machine, the user should be familiar with the following section, which contains information on the hazards associated with the press, as well as step-by-step instructions for its safe and effective use.

Safety Hazards

Use of the Compression Tester Shop Press comes with several inherent dangers.

Pinch Points: In order for the machine to function properly, the press plate must slide vertically on the frame. Users should be cautious to avoid getting any body part, long hair, jewelry or loose clothing near the sliding press plate during operation.

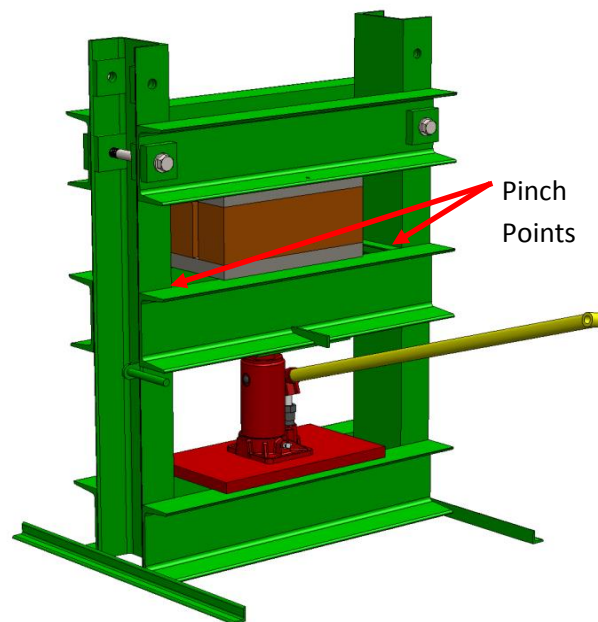

Figure 40. Pinch points in the press.

Crushing: The frame of the press is very heavy. Care should be taken at all times to ensure that no component of the machine is dropped or falls onto the user. Assembly, disassembly, and reorientation of the machine require users to raise individual components, such as the sliding press plate, upper C-channels and hydraulic jacks. For safety, a minimum of two people is required to assist with these activities.

High Forces: Hydraulic jacks are capable of applying extremely high forces. Extreme caution should be exercised to ensure that the user does not get any part of the body trapped between

the extending piston and the machine's frame. Users should refrain from touching any part of the shop press mechanism any time the hydraulic jack is in use.

Operation Manual

The press was designed to serve many different purposes, and has several unique features. This manual contains information on how to utilize the press with regards to:

- I. Assembly and Disassembly
- II. Compression Test
- III. Bending Test
- IV. Shop Press Functionality: Pushing Bushings/Bearings

Assembly and Disassembly

For ease of transportation, the compression tester was designed to be easily taken apart and put back together. The machine breaks down into four main components:

1. Frame Base
2. Sliding Press Plate
3. Upper C-Channels (2)

To assemble the press for use, the following steps should be taken:

Step 1: Place the frame base on a flat, sturdy work surface. The press can be used on a table or the ground, as long as the surface is stable.

Step 2: Install the sliding press plate. This is accomplished by lifting the press plate over the vertical C-Channels and allowing it to slide downwards. Orient the press plate properly by ensuring that the contact plate is on the bottom side of the press plate, and the recompression tab is located on the same side of the frame as the recompression rod. If the press plate is installed upside down (with the contact plate on the top side) then the machine will not work properly. Likewise, if the plate is installed backwards, the recompression tab will be on the wrong side of the frame, and the jack recompression mechanism will be impossible to use.

Step 3: Choose a height setting. In order to allow for greater functionality, the machine has two height settings, one of which may be more useful depending on the operation that is being performed, the object being pressed, and the size of the hydraulic jack being used.

Step 4: Orient the upper C-channels. Once a height setting has been chosen, add the upper C-channels to the frame by lining up the proper through holes in the vertical and upper C-channels, and inserting the bolts through the holes. Ensure that the upper C-channels are

oriented correctly, with the pressing tool attachment holes on the bottom side. If the C-channels are installed upside down, the pressing tool attachment cannot be used.

Step 5: Fasten the C-channels. Once the upper C-channels are properly oriented, use a wrench to tighten the bolts.

To disassemble the press, simply follow the steps in reverse order.

Compression Test

The purpose of the compression test is to apply pressure to the surface of the ICEBs and measure the stress in the block at the point of failure. To use the machine to conduct compression tests, the following steps should be followed:

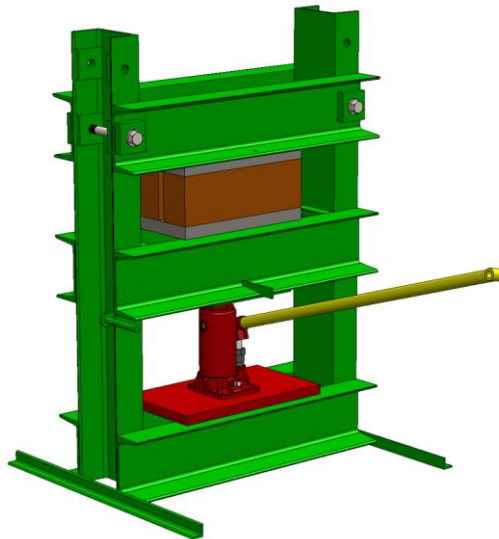

Figure 41. Compression test set up.

Step 1: Verify that the frame is adjusted to the lower of the two height settings. If it is not, remove the bolts from the upper beams, realign the beams with the lower set of through holes on the vertical members, and reinstall the bolts.

Step 2: Insert the 20-ton hydraulic jack into the frame. To accomplish this, first slide the sliding press plate upwards until there is enough clearance for the jack to fit beneath it. Once the jack is in position, lower the sliding press plate and allow it to rest on the top of the jack's piston. In order to prevent the sliding press plate from binding as the jack extends, care should be taken to ensure that both the jack and the press plate are centered on the machine.

Step 3: Place the ICEB and companion plates on the sliding press plate, as shown in **Figure 41**.

Step 4: Engage the hydraulic jack. As the jack extends, the sliding press plate and the ICEB assembly will also rise. Raise the height of the jack until the top of the ICEB plate contacts the upper beams.

Step 5: Use the jack to increase the pressure on the block until the desired failure is achieved in the block. Since the gauge does not retain the maximum value, the needle will return to zero once the block has fully failed. It is necessary to watch the gauge in order to determine the pressure in the jack at the time of failure.

Step 6: Recompress the hydraulic jack (“Hydraulic Jack Recompression” section).

Bending Test

The bending test is used to apply a bending force to the paving slabs and measure the force that is necessary to fracture the slabs. To conduct bending tests, the following steps should be followed:

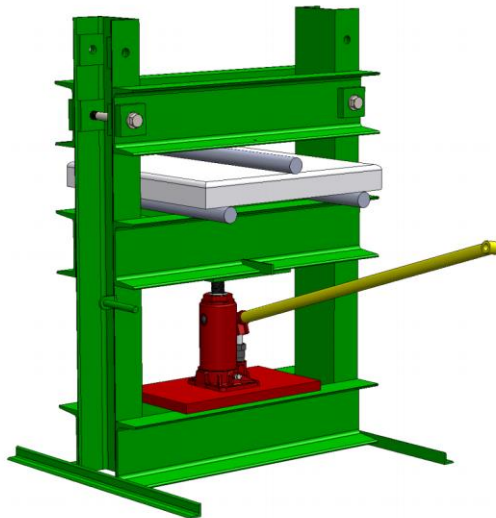

Figure 42. Bending test set up.

Step 1: Verify that the frame is adjusted to the lower of the two height settings. If it is not, remove the bolts from the upper beams, realign the beams with the lower set of through holes on the vertical members, and reinstall the bolts.

Step 2: Insert the 1.5-5 ton hydraulic jack into the frame. See Step 2 from the Compression Test instructions.

Step 3: Place the paving slab and testing jig onto the sliding press plate, as shown in **Figure 42**.

Step 4: Engage the hydraulic jack. Raise the height of the jack until the top of the testing jig contacts the upper beams.

Step 5: Use the jack to increase the load on the paving slab until the desired force is reached.

Step 6: Recompress the hydraulic jack (“Hydraulic Jack Recompression” section).

Shop Press Functionality: Pushing Bushings/Bearings

The ability to press bearings and bushings expands the CVBT’s ability to perform maintenance on various pieces of equipment. In order to configure the machine to do this, the following steps will be followed:

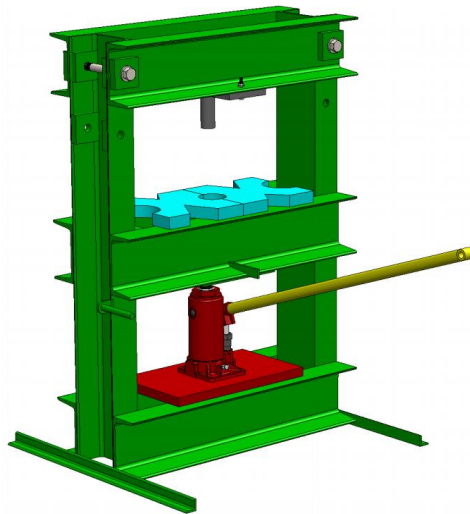

Figure 43. Bearing/bushing pressing set up.

Step 1: Verify that the frame is adjusted to the higher of the two height settings. If it is not, remove the bolts from the upper beams, realign the beams with the upper set of through holes on the vertical members, and reinstall the bolts. Setting the frame to the highest setting allows enough space for equipment to be inserted into the machine.

Step 2: Install the pressing tool attachment. This is accomplished by inserting the two tool attachment bolts through the holes in the tool attachment and the upper C-channels, and installing the washers and nuts.

Step 3: Insert the appropriately sized jack into the frame. See Step 2 from the Compression Test or Bending Test section.

Step 4: Place the work piece on the sliding press plate. If the work piece is too small to span the gap between the C-channels, then a jig may be used to create an appropriately sized gap. Ensure that the work piece is centered on the press and oriented directly below the pressing tool attachment.

Step 5: When the work piece is properly aligned, engage the hydraulic jack. As the sliding press plate begins to rise, be sure that the work piece remains in the proper location.

Hydraulic Jack Recompression

In order to assist the user in recompressing the hydraulic jack once it has been fully extended, the machine has been designed to include a recompression mechanism. Often, the combined weight of the sliding press plate and the work piece is enough to recompress the jack. If this is not the case, the following steps can be taken:

Step 1: Remove the jack handle. The handle that is used to pump the hydraulic jack is easily separated by pulling it from the cylindrical seat on the jack's housing.

Step 2: Release the pressure in the hydraulic jack. This is accomplished by turning the pressure release valve counterclockwise.



Figure 44. Jack fluid pressure release mechanism.

Step 3: Mount the compression lever to the recompression rod on the left side of the frame. The recompression rod acts simply as a pivoting point for the lever, and mates to the through hole on one side of the lever.

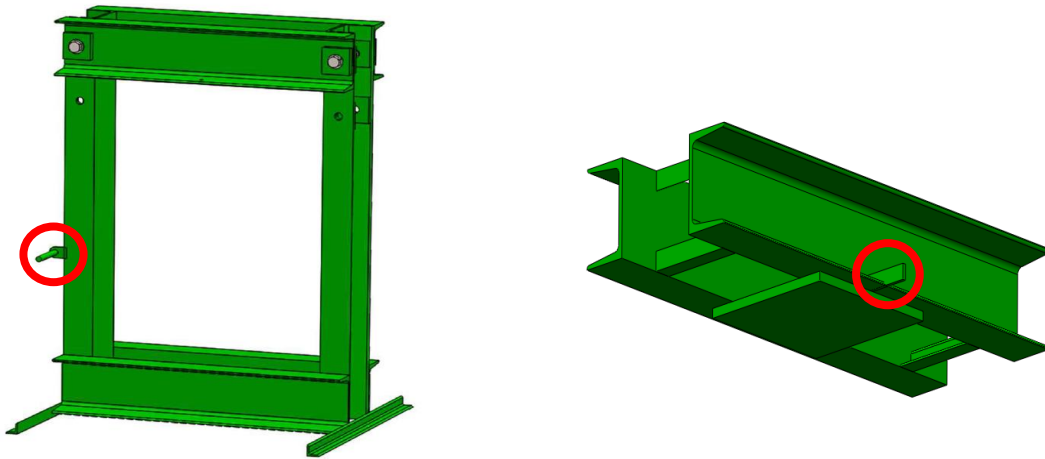

Figure 45. (Left) Jack recompression rod. (Right) Jack recompression tab.

Step 4: Bring the lever into contact with the recompression tab, which is located on the sliding press plate. Pivoting the lever on the recompression rod, use it to apply a downward force to the recompression tab and sliding press plate. This will cause the jack to recompress.

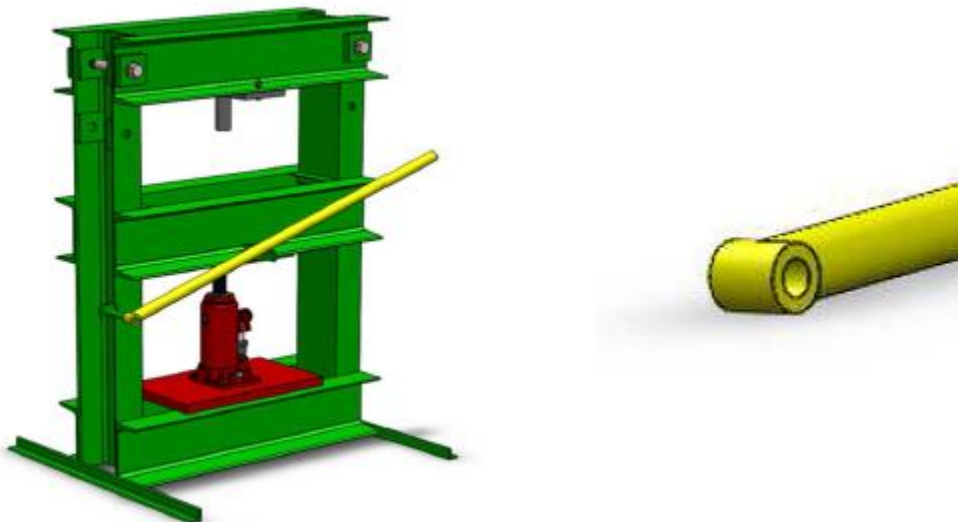

Figure 46. (Left) Jack recompression set up. (Right) Jack handle, to be used for recompression lever.

Determining Stress and Force Using the Gauge

The hydraulic jack is fitted with a gauge that allows the user to read the pressure within the jack. To translate the gauge pressure to the force that is being applied by the jack, the gauge reading should be multiplied by a factor of 3.729.

When completing a compression test on an ICEB, it is also necessary to use a conversion factor in order to determine the stress in the block. This is done by relating the fluid contact area of the hydraulic jack piston to the contact area of the ICEB. The chart in **Appendix M** can be used to easily determine the stress in the block based on the pressure within the hydraulic jack.

Appendix N: Pressure Conversion Table

Gauge Pressure (psi)	Applied Force (lb)	Stress in Block (psi)	Stress in Block (Mpa)
400.00	1491.64	24.80	0.17
800.00	2983.28	49.61	0.34
1200.00	4474.92	74.41	0.51
1600.00	5966.56	99.21	0.68
2000.00	7458.21	124.01	0.86
2400.00	8949.85	148.82	1.03
2800.00	10441.49	173.62	1.20
3200.00	11933.13	198.42	1.37
3600.00	13424.77	223.23	1.54
4000.00	14916.41	248.03	1.71
4400.00	16408.05	272.83	1.88
4800.00	17899.69	297.63	2.05
5200.00	19391.33	322.44	2.22
5600.00	20882.98	347.24	2.39
6000.00	22374.62	372.04	2.57
6400.00	23866.26	396.84	2.74
6800.00	25357.90	421.65	2.91
7200.00	26849.54	446.45	3.08
7600.00	28341.18	471.25	3.25
8000.00	29832.82	496.06	3.42
8400.00	31324.46	520.86	3.59
8800.00	32816.10	545.66	3.76
9200.00	34307.74	570.46	3.93
9600.00	35799.39	595.27	4.10
10000.00	37291.03	620.07	4.28
10400.00	38782.67	644.87	4.45
10800.00	40274.31	669.68	4.62